

87

つけた折り筋で中割り折り

88

反対側へかるくひろげる

89

隙間へ折り込む

90

87-89
反対側も87-89と
同じように折る

96

カドをつまむように折る

95

半分に折る

91

92

内側をひろげて
つぶすように折る

97

カドを少し
ひろげるように折る

94

92
反対側も92と
同じように折る

98

96-97

反対側も96-97と
同じように折る

93

99

102

カドを内側に
折り込む

100

両側で斜めに段折り

101

中割り折り

108

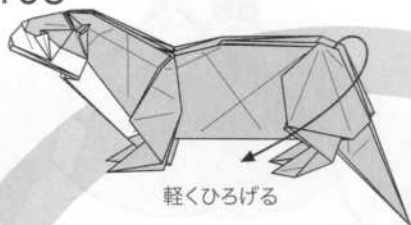

107

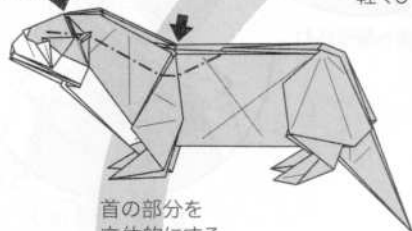

106

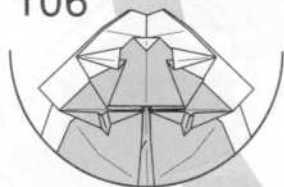

105

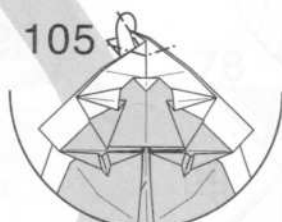

カドを後ろへ折り込む

104

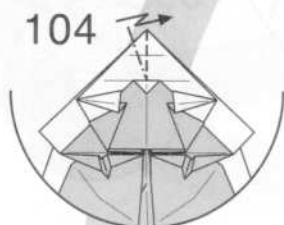

引き寄せるように段折り

103

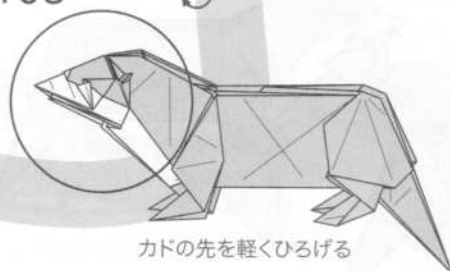

109

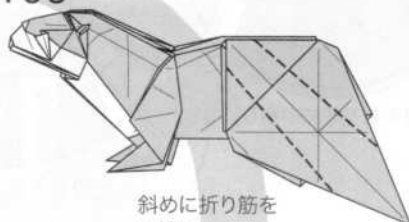

110

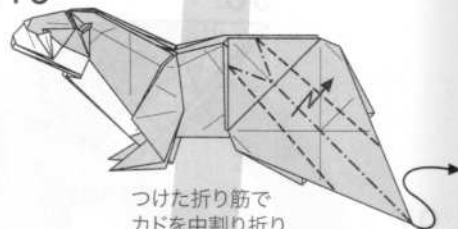

111

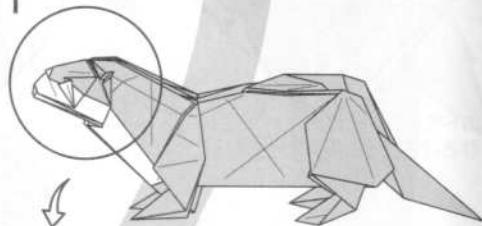

112

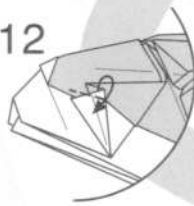

フチをひろげて目を作る

113

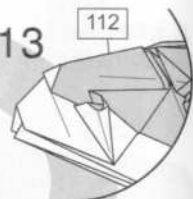

反対側も112と同じように折る

114

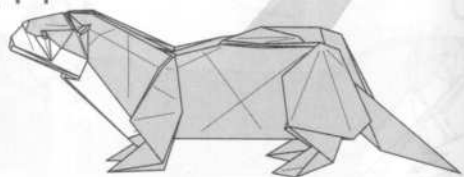

完成

コウモリ *Bat*

作・図 佐藤悠樹

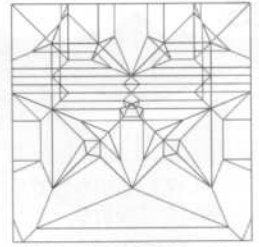

推奨：表裏同色、35cm以上

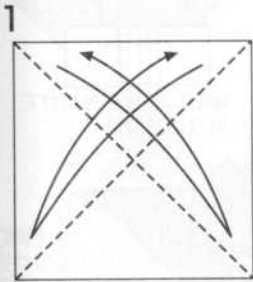

1 対角に折り目をつける

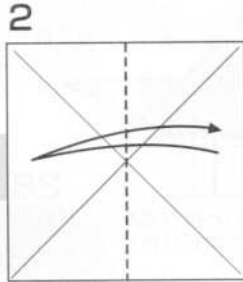

2 縦に半分に折り目をつける

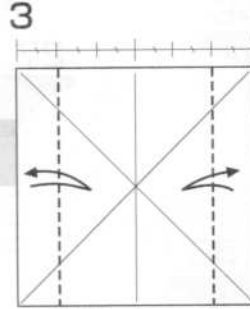

3 3等分のところで折り目をつける

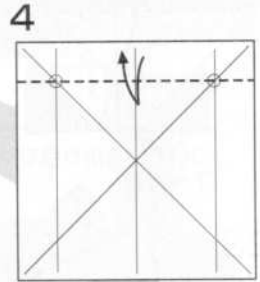

4 ○を結ぶ線で折り目をつける

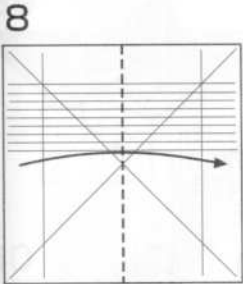

8 半分に折る

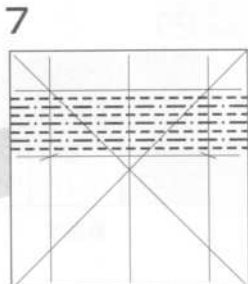

7 折り目の間に8等分の折り目をつける

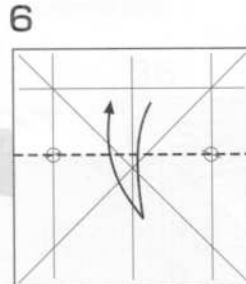

6 印を結ぶ線で折り目をつける

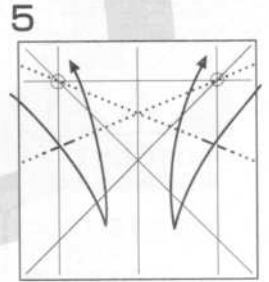

5 ○の角を二等分する線で3でつけた折り目の部分に印をつける

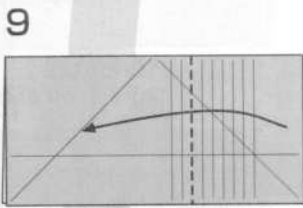

9 ついている折り目で折る

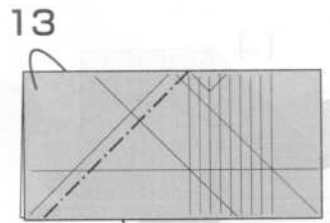

13 ついている折り目にふちを合わせて後ろへ折る

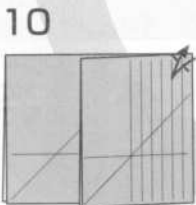

10 ついている折り目にふちを合わせて折り目をつける

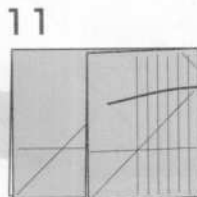

11 開く

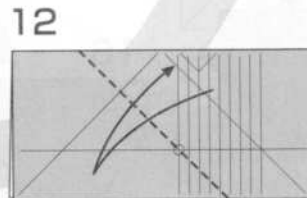

12 ○の角を二等分する折り目をつける

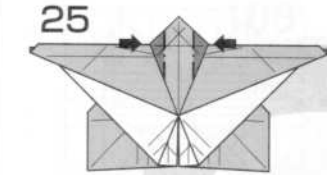

25
ついている折り目で
開いた沈め折り

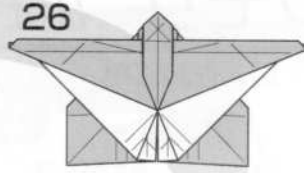

26
裏返す

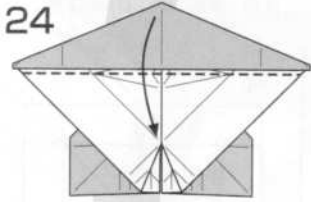

24
ついている折り目で
下へ折る

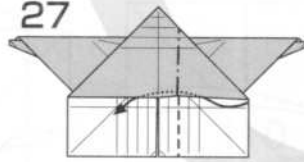

27
ついている折り目を
つかって中わり折り

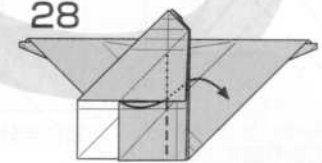

28
ついている折り目を
つかって中わり折り

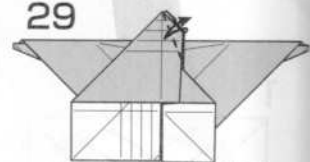

29
中心にふちを合わせて
折り目をつける

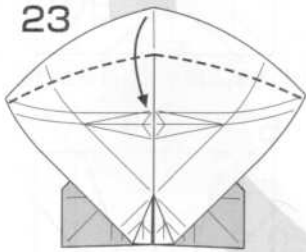

23
中心を合わせて
平らに折りたたむ

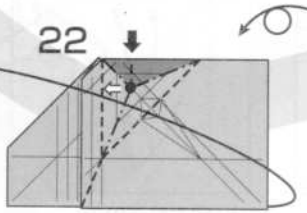

22
ついている折り目で
上部をつぶしながら広げる
平らにはならない

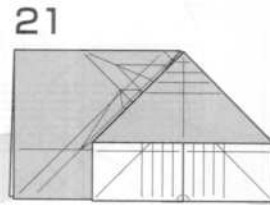

21
裏返す

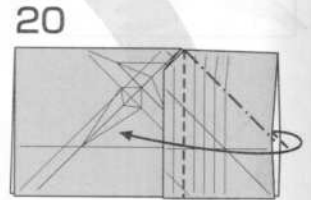

20
内側を広げて
つぶすように折る

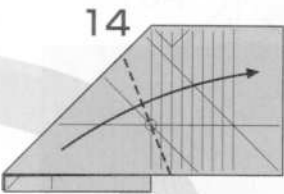

14
Oの角を二等分するように折る

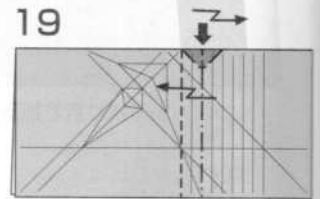

19
中央をつぶす
ようにしながら
両側で段折り

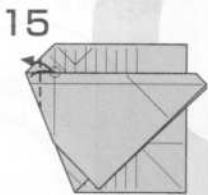

15
Oにカドを合わせて
折り目をつける

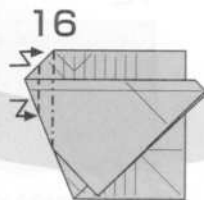

16
つけた折り目で
両側で段折り

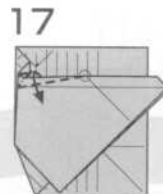

17
Oを通る線で
引き寄せるように
折る

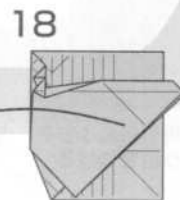

18
開く

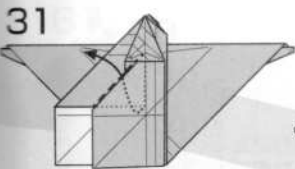

31
手前のふちに
合わせて
中わり折り

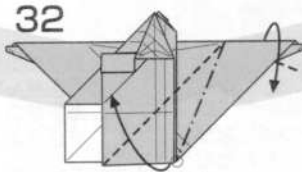

32
ついている折り目と
○を通る線で引き寄せる
ように折る

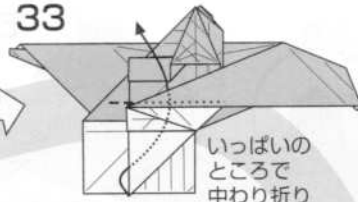

33
いっぱい
の
ところ
で
中わり折り

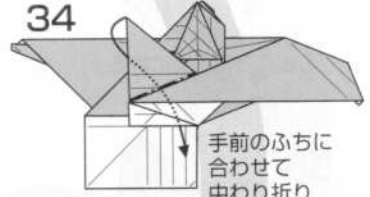

34
手前のふちに
合わせて
中わり折り

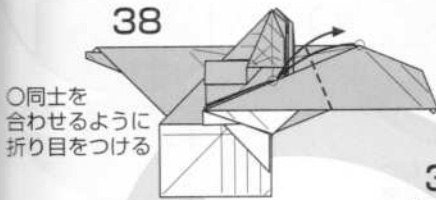

38
○同士を
合わせるように
折り目をつける

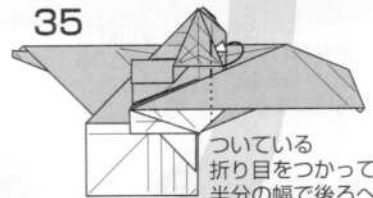

35
ついている
折り目をつかって
半分の幅で後ろへ
折る

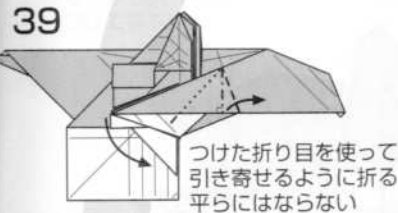

39
つけた折り目を使って
引き寄せるように折る
平らにはならない

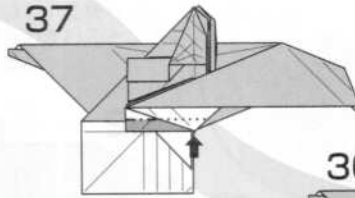

37
ついている折り目で
閉じた沈め折り

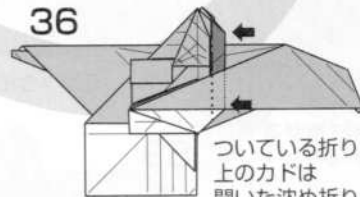

36
ついている折り目で
上のカドは
開いた沈め折り
下のカドは
閉じた沈め折り

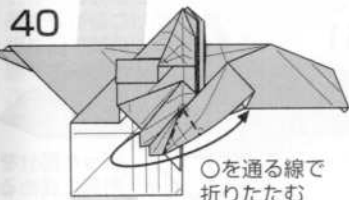

40
○を通る線で
折りたたむ

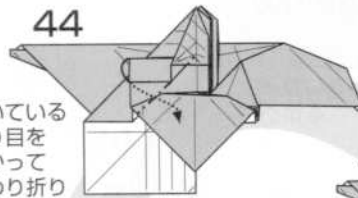

44
ついている
折り目を
つかって
中わり折り

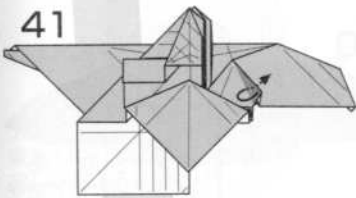

41
ひだを内側に入れる

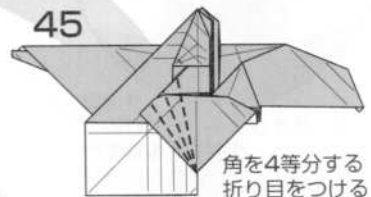

45
角を4等分する
折り目をつける

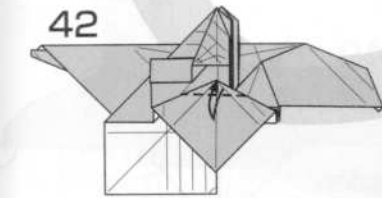

42
いっぱい
の
ところ
で
折り目をつける

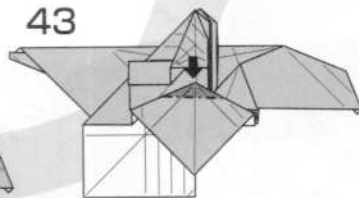

43
つけた折り目で
開いた沈め折り

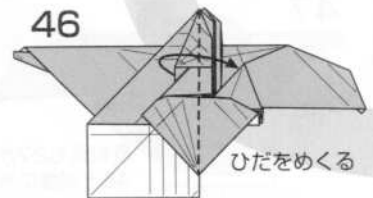

46
ひだをめくる

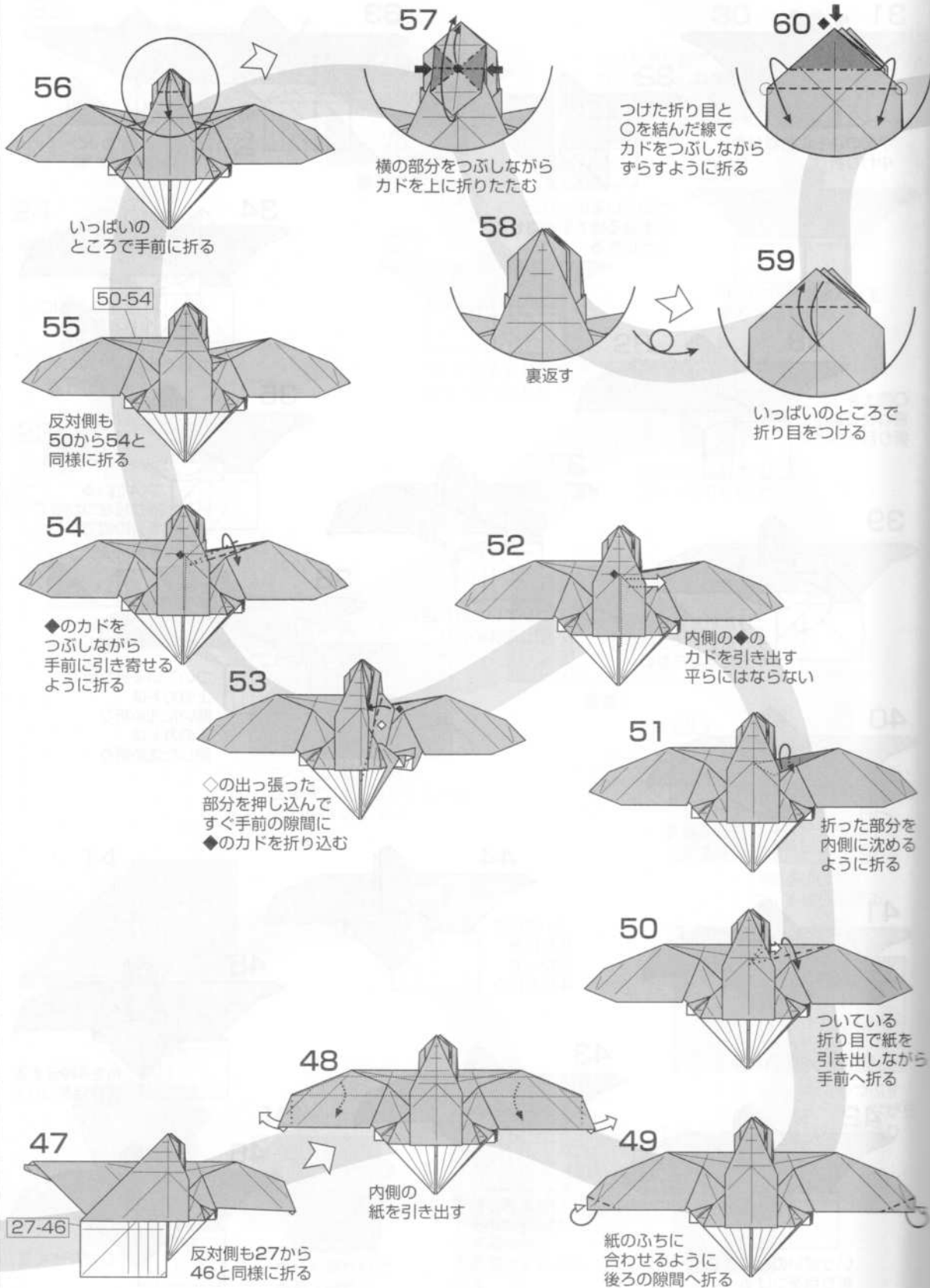

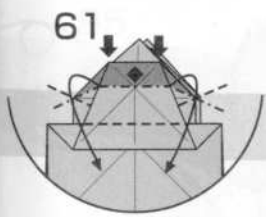

61

ついている折り目をつかってカドをつぶしながら手前に折る



62

ひだを上へ折りながらついている折り目をつかって折りたたむ

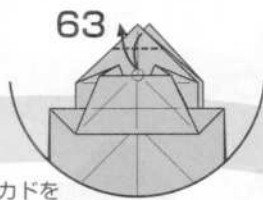

63

カドをふちに合わせて折り目をつける

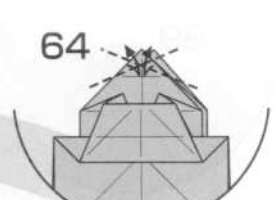

64

つけた折り目にふちを合せて折り目をつける

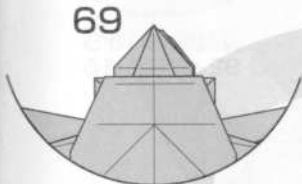

69

しっかり折り目をつけて戻す

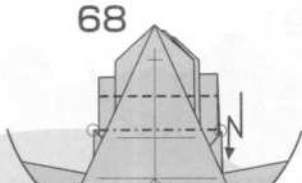

68

ついている折り目と厚みの変わるところで段折り

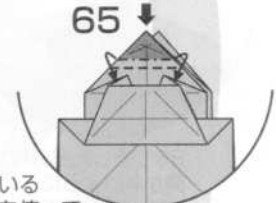

65

ついている折り目を使って60と同様にカドをつぶしながらずらすように折る



67

裏返す
次の図から小さくなる

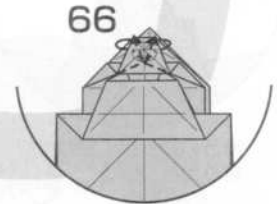

66

ひだを上へ折りながらついている折り目を使って折りたたむ

幅の変わる
ところのひだを開きながらつけた折り目で両側で段折りして頭を押し込むように折る
次の図から横から見る

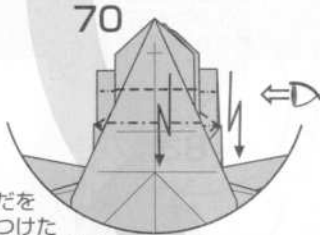

70

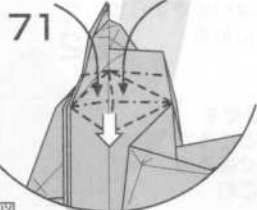

71

70の途中図
紙を1枚引き出し頭をつまんで押し込むように折る

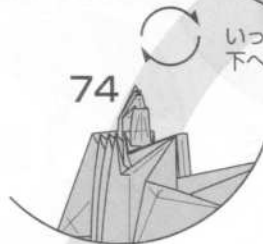

74

視点を戻す

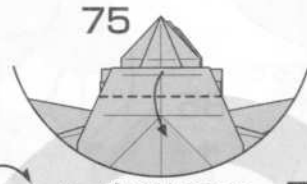

75

いっぱいのところを下へ折る

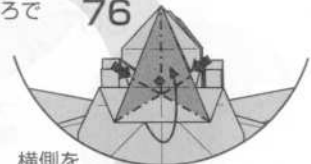

76

横側をつぶしながら◆のカドをつまむように折る
平らにはならない



72

ひだを1枚引き出して折りたたむ



73

残り2枚のひだも同様に引き出して折りたたむ
反対側も同じ

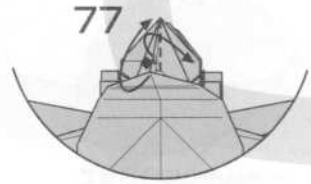

77

平らに折りたたむ

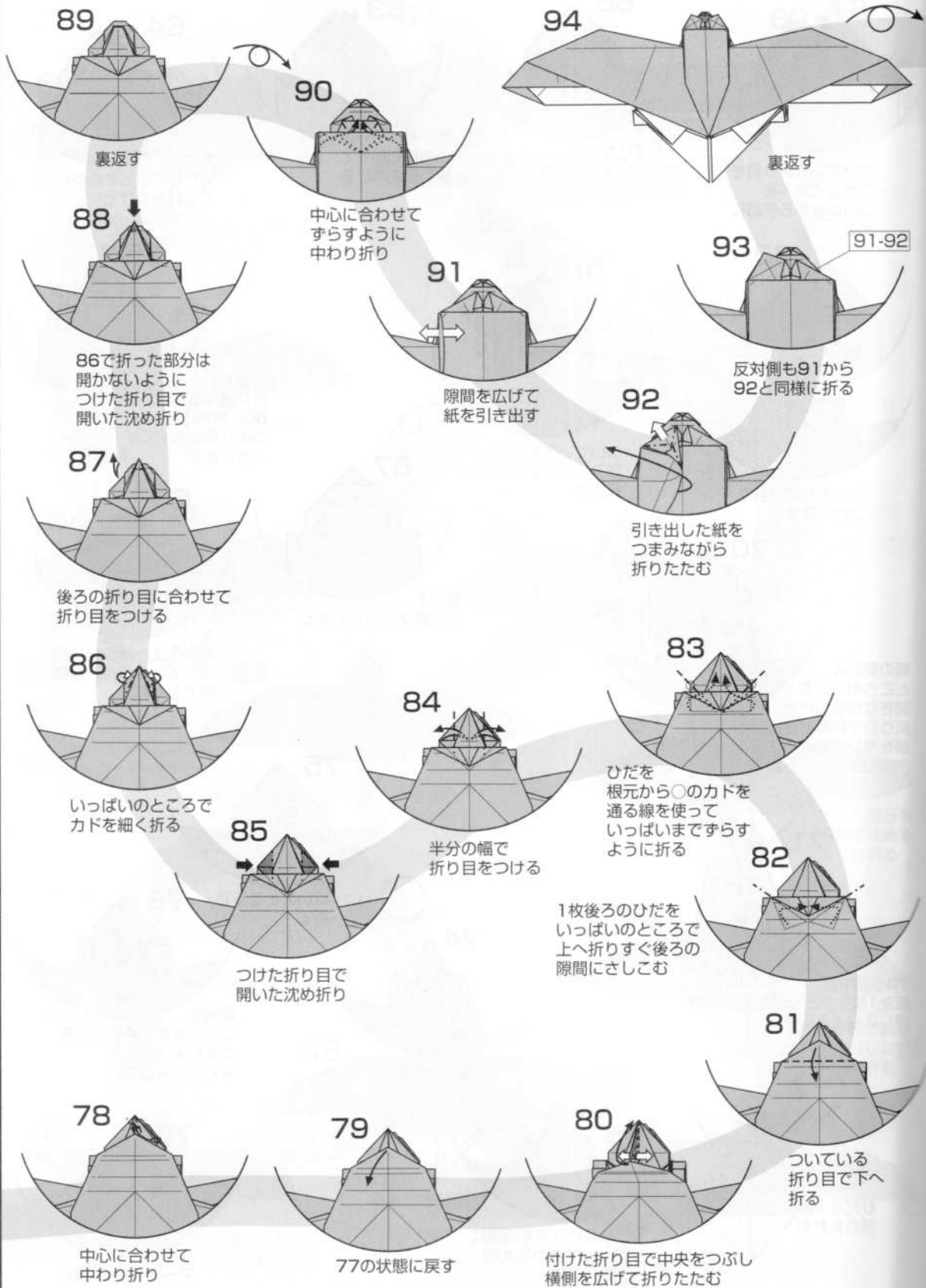

95

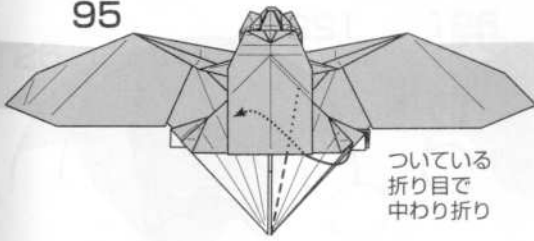

ついている
折り目で
中わり折り

96

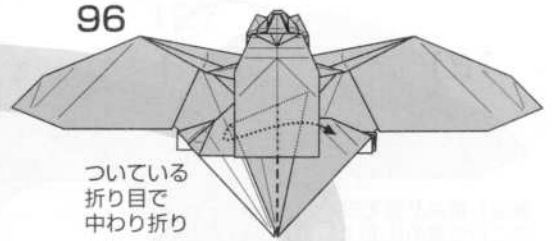

ついている
折り目で
中わり折り

98

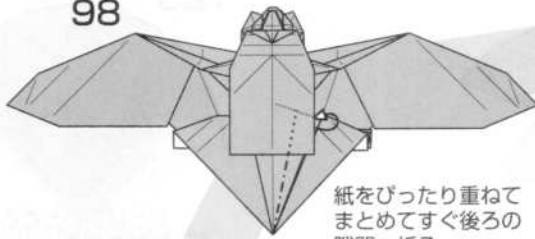

紙をぴったり重ねて
まとめてすぐ後ろの
隙間へ折る

97

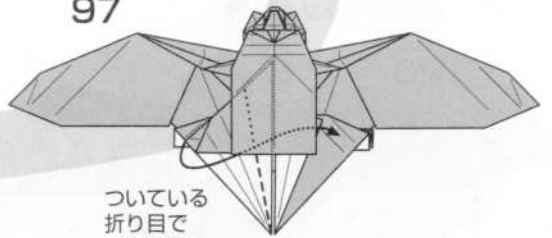

ついている
折り目で
中わり折り

99

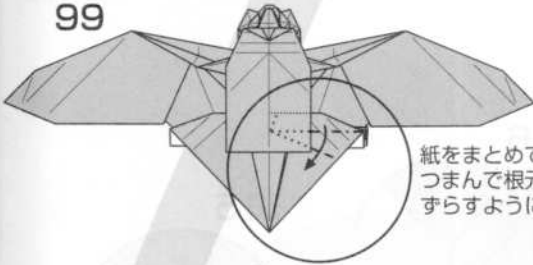

紙をまとめて
つまんで根元から
ずらすように折る

106



折り目に
ふちを合わせて
中わり折り

100

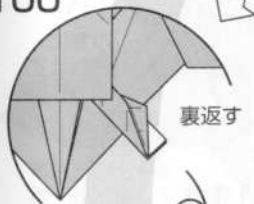

裏返す

105

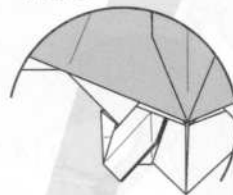

裏返す

107

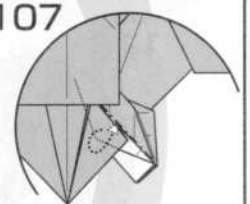

すぐ後ろの隙間へ
さしこむ

101

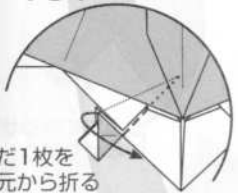

ひだ1枚を
根元から折る

104



半分の幅で
後ろに折る

108

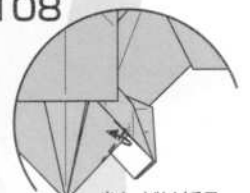

少しだけ折る

102

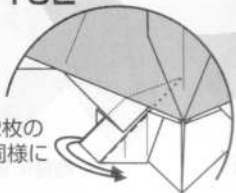

残りの2枚の
ひだも同様に
折る

103



ひだの
上下を根元から
いれかえる

109

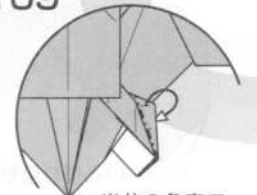

半分の角度で
後ろへ折る

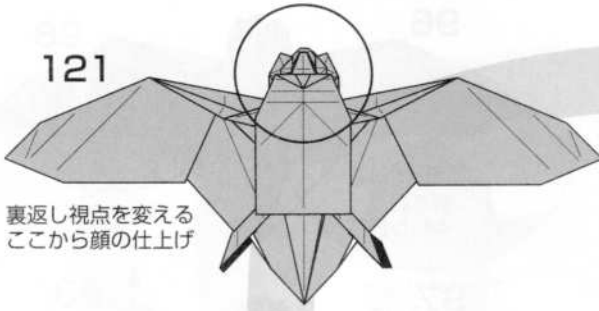

121

裏返し視点を変える
ここから顔の仕上げ



122

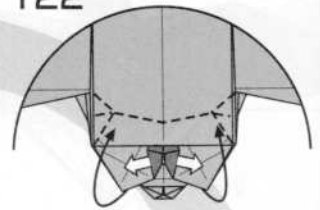

ひだを引き出しながら
耳を立てて形を整える

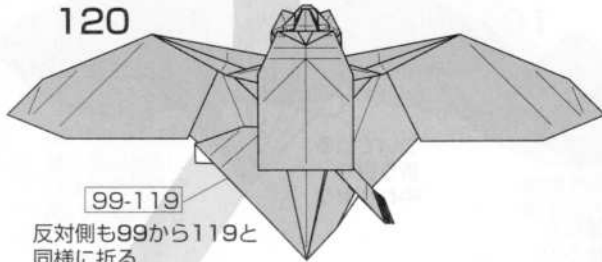

120

99-119

反対側も99から119と
同様に折る

123

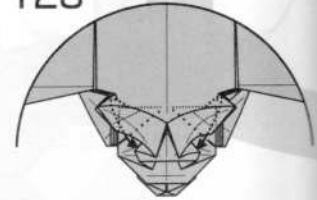

いっばいのところで
ひだを折る

119

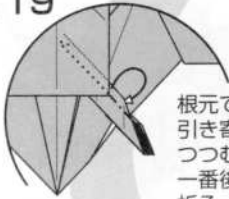

根元で
引き寄せながら
つつむように
一番後ろの隙間へ
折る

116



ふちに合せて
中わり折り

115



ふちに
合わせて
中わり折り

118



後ろのカドを
半分の幅で
手前に折る

117

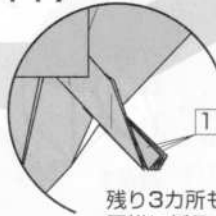

残り3カ所も
同様に折る

114-116

114

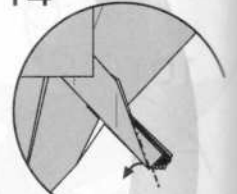

ふちに合せて
中わり折り

110

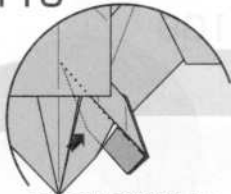

ついている折り目で
閉じた沈め折り

111

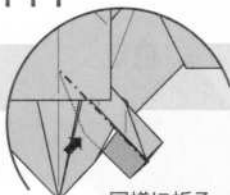

同様に折る
次の図から
小さくなる

112

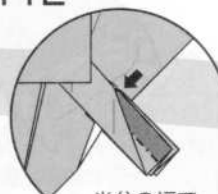

半分の幅で
閉じた沈め折り

113

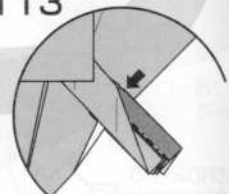

同様に折る

125

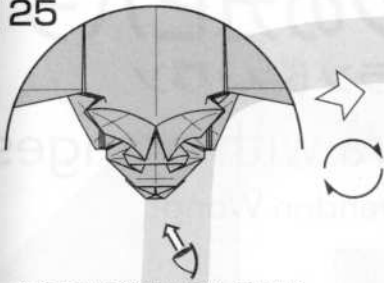

次の図から斜め上に視点を置く

126

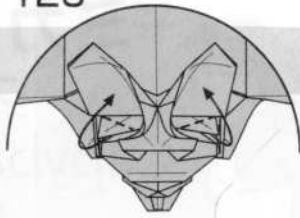

カドを立てる

127

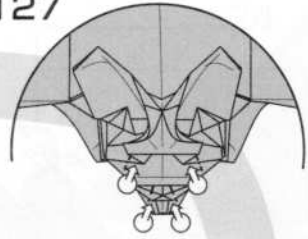

目と鼻の穴を
ふくらませるように折る

124

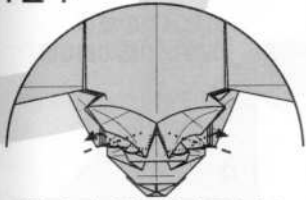

折ったカドを細くするように
中わり折り

128

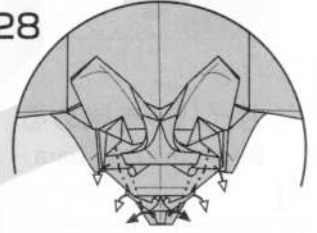

上下の歯を折る
顔の形を整える

129



裏返す
視点を戻す

130

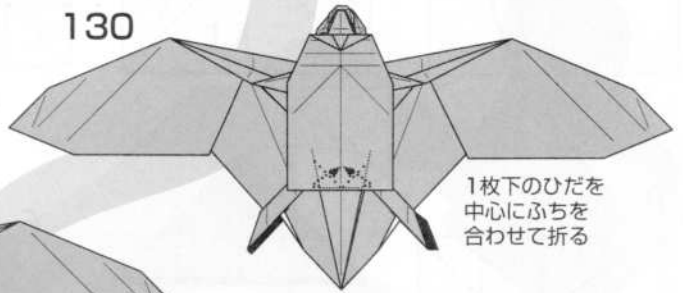

1枚下のひだを
中心にふちを
合わせて折る

131

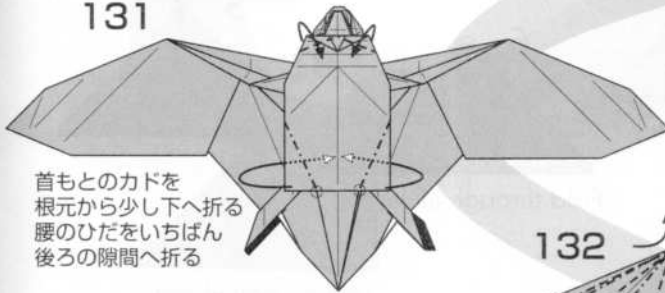

首もとのカドを
根元から少し下へ折る
腰のひだをいちばん
後ろの隙間へ折る

132

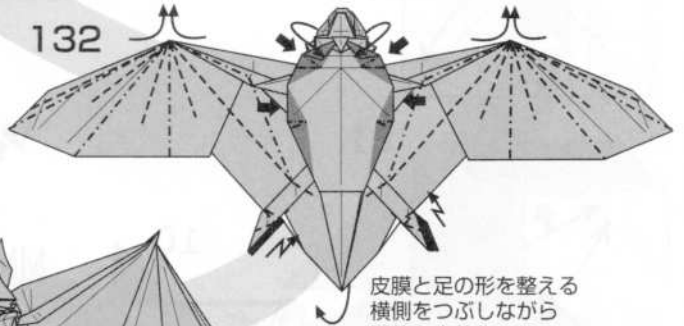

皮膜と足の形を整える
横側をつぶしながら
胴体を立体化する
体の膨らみに沿わせるように
上顎から首もとのひだを
折り曲げる

133



完成

ミカンのカピバラ

ブランドン・ワン

Capybara with oranges

Brandon Wong

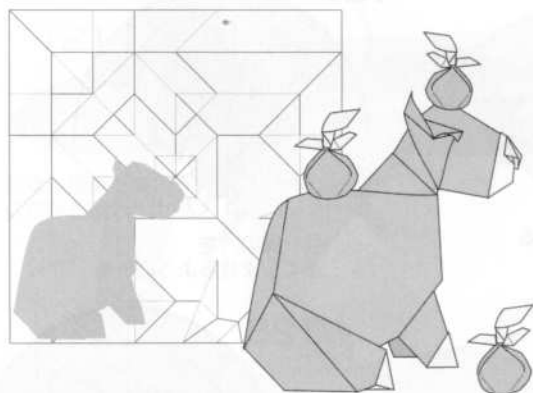

カピバラを始める
Begin the capybara

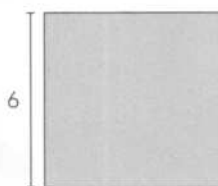

The capybara paper should be about 6x the orange paper

カピバラの紙は
ミカンの紙の約6倍

1

2

3

4

5

6

7

8

9

10

11

12

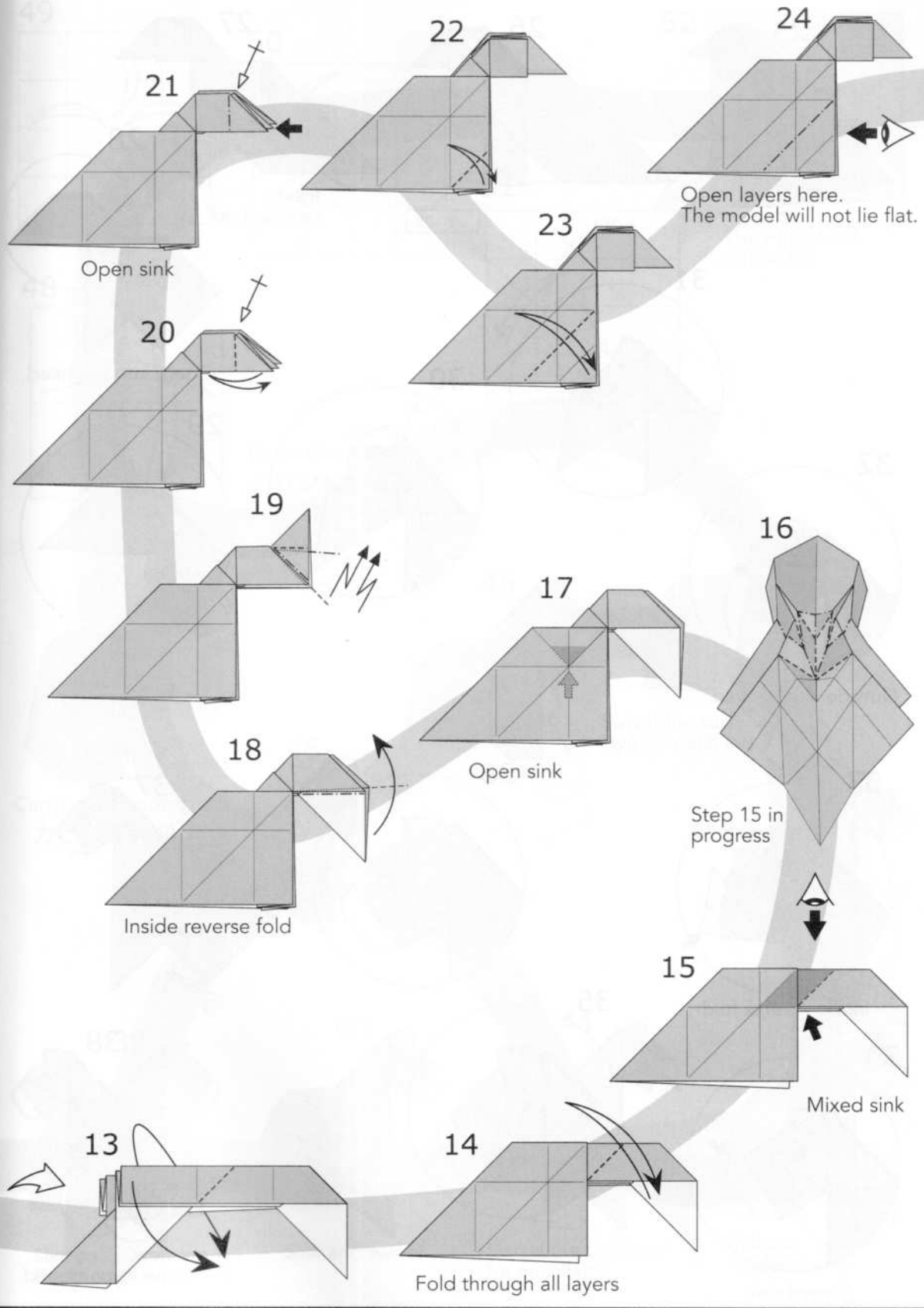

21

22

24

Open sink

Open layers here.
The model will not lie flat.

20

23

19

17

16

18

Open sink

Step 15 in
progress

15

Inside reverse fold

Mixed sink

13

14

Fold through all layers

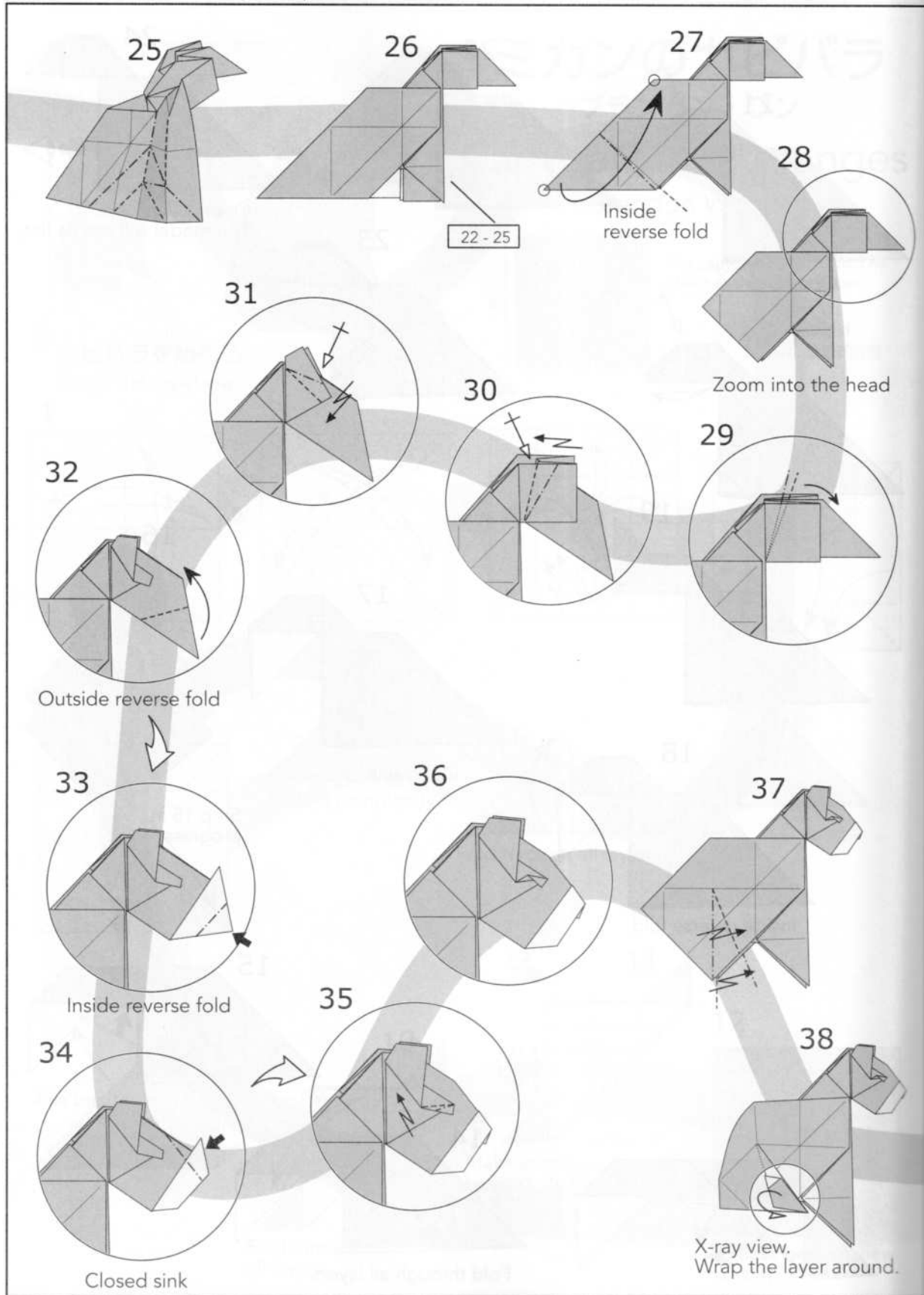

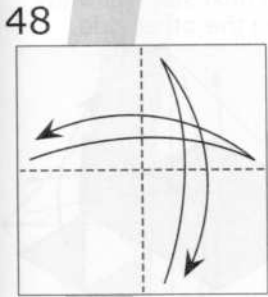
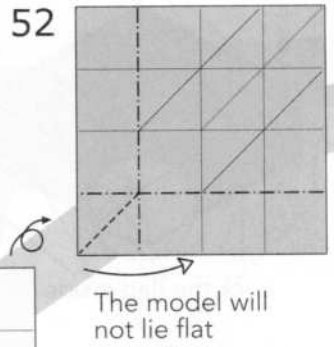
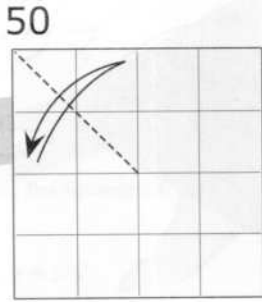
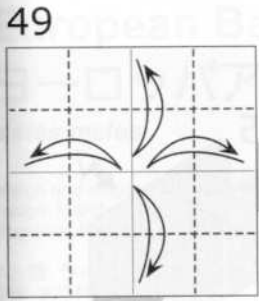

Begin the orange
ミカンを始める

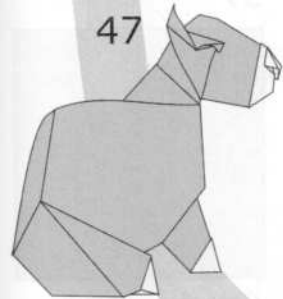
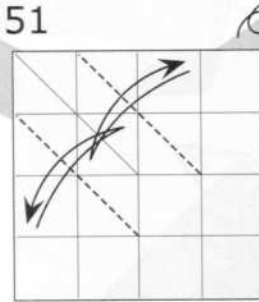

Capybara complete
カピバラ完成

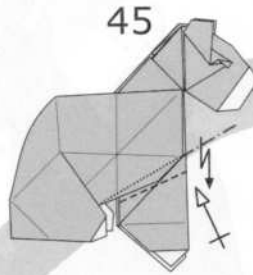
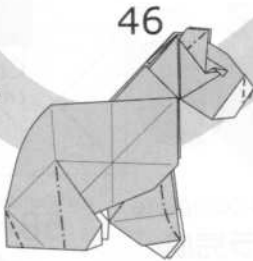

Swivel the top
layer for each leg

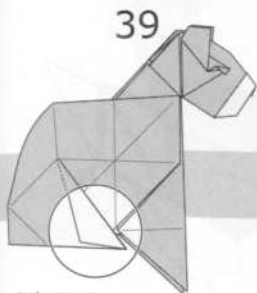
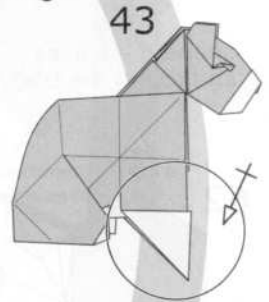
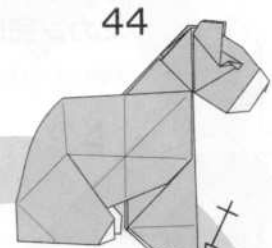

Like so.
Back to full view

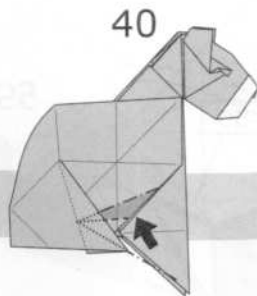

Sink and swivel

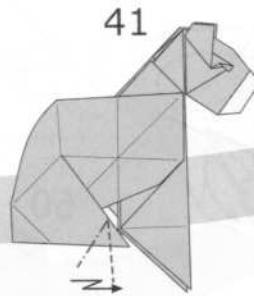

Swivel the top layer
for each leg

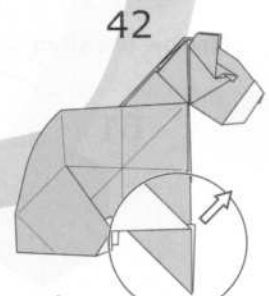

Release
hidden layers

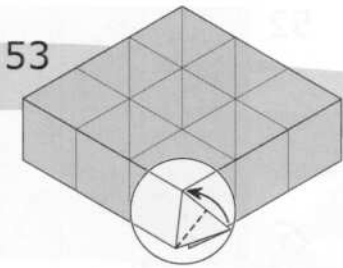

53

Lock the flap inside

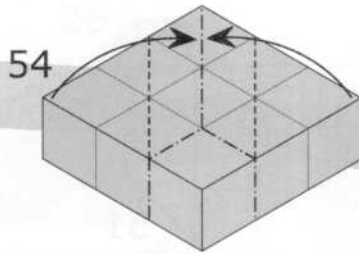

54

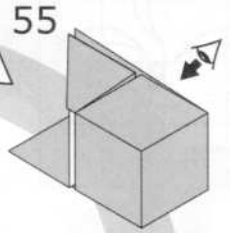

55

The next step will view from the other side

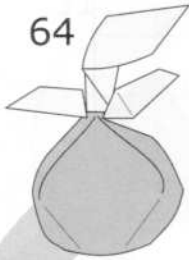

64

Orange complete
ミカン完成

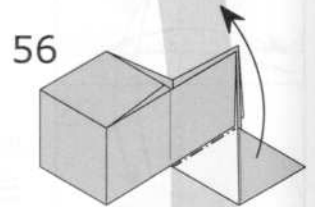

56

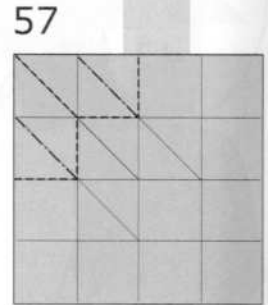

57

Crease pattern view of step 55

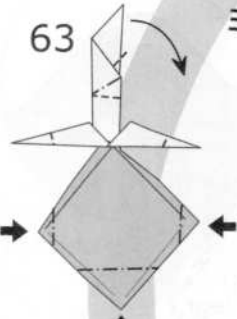

63

Shape the leaves and round the body



Capybara with oranges complete
ミカンのカピバラ完成

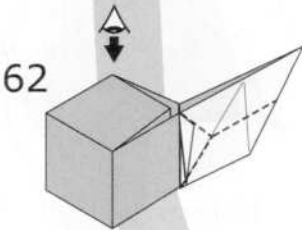

62

Narrow the stem

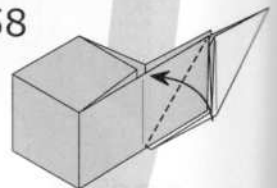

58

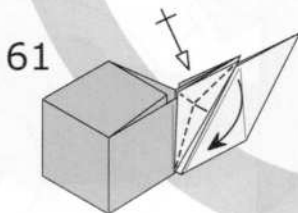

61

Pinch the leaf into roughly a rabbit ear

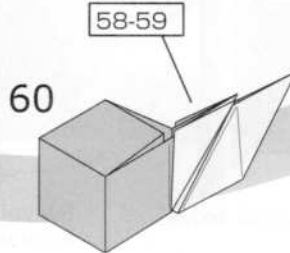

60

58-59

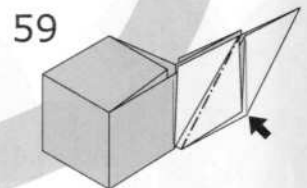

59

European Badger ヨーロッパアナグマ

Meles meles

Design and diagrams: Ryan Welsh
Design: March 2024
Diagrams: April/May 2024, Amsterdam, The Netherlands

作と図: ライアン・ウェルシュ
創作: 2024年3月
図: 2024年4-5月, アムステルダム, オランダ

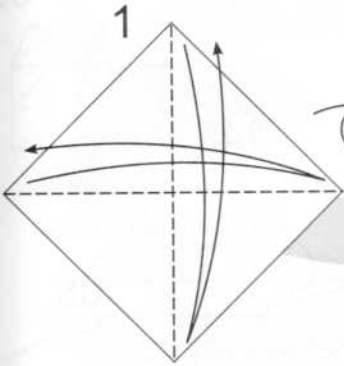
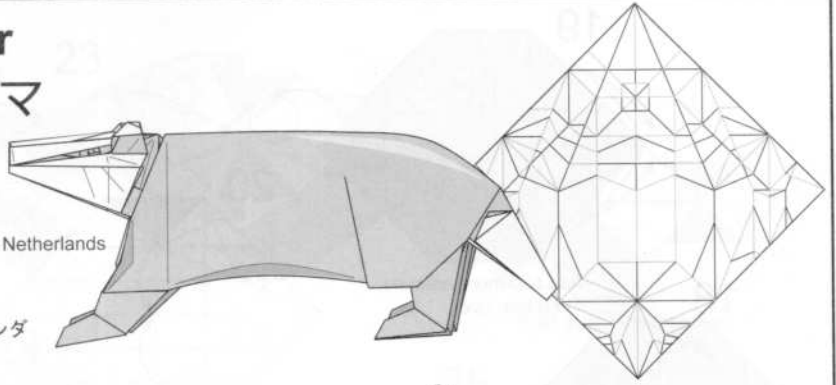

Whiteside up. Fold and unfold along the diagonals. Then turn over.

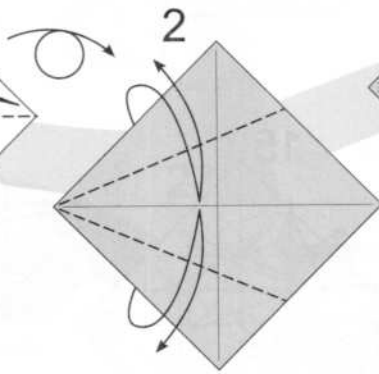

Fold the edges to the center and unfold.

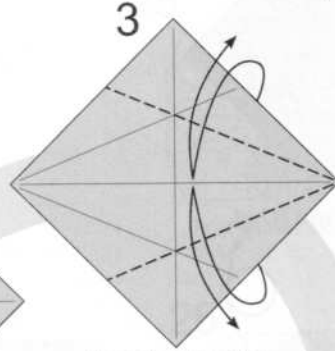

Repeat on the right.

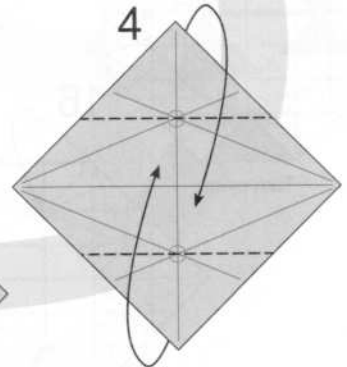

Fold in the corners using the shown points as reference.

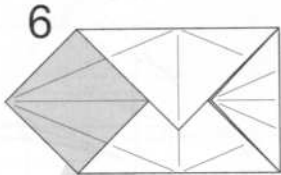

Fold the right corner.

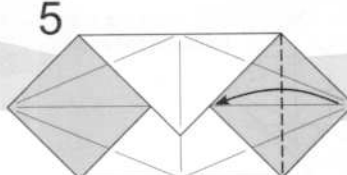

Unfold completely and turn over.

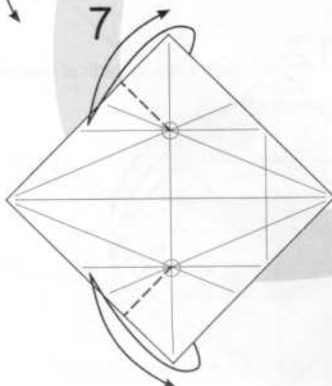

Fold perpendicular to the edge and unfold.

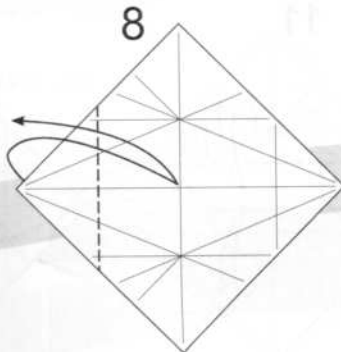

Fold the left corner to the center and unfold.

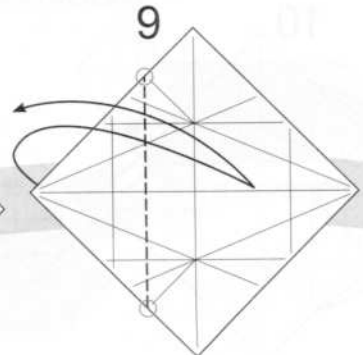

Fold and unfold the left corner again starting at the points shown.

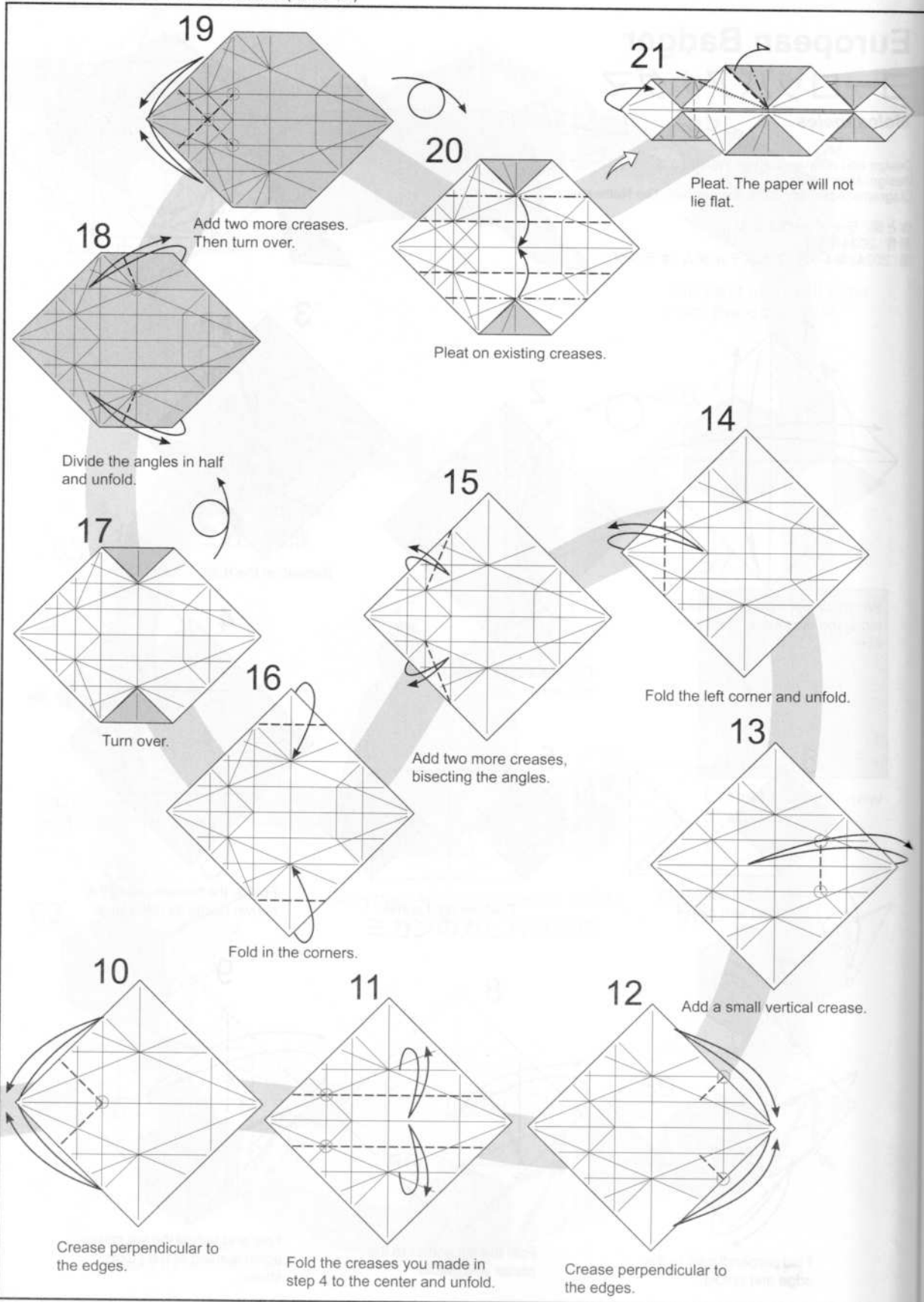

Crease perpendicular to the edges.

Fold the creases you made in step 4 to the center and unfold.

Crease perpendicular to the edges.

Add two more creases. Then turn over.

Pleat on existing creases.

Pleat. The paper will not lie flat.

Divide the angles in half and unfold.

Turn over.

Add two more creases, bisecting the angles.

Fold the left corner and unfold.

Fold in the corners.

Add a small vertical crease.

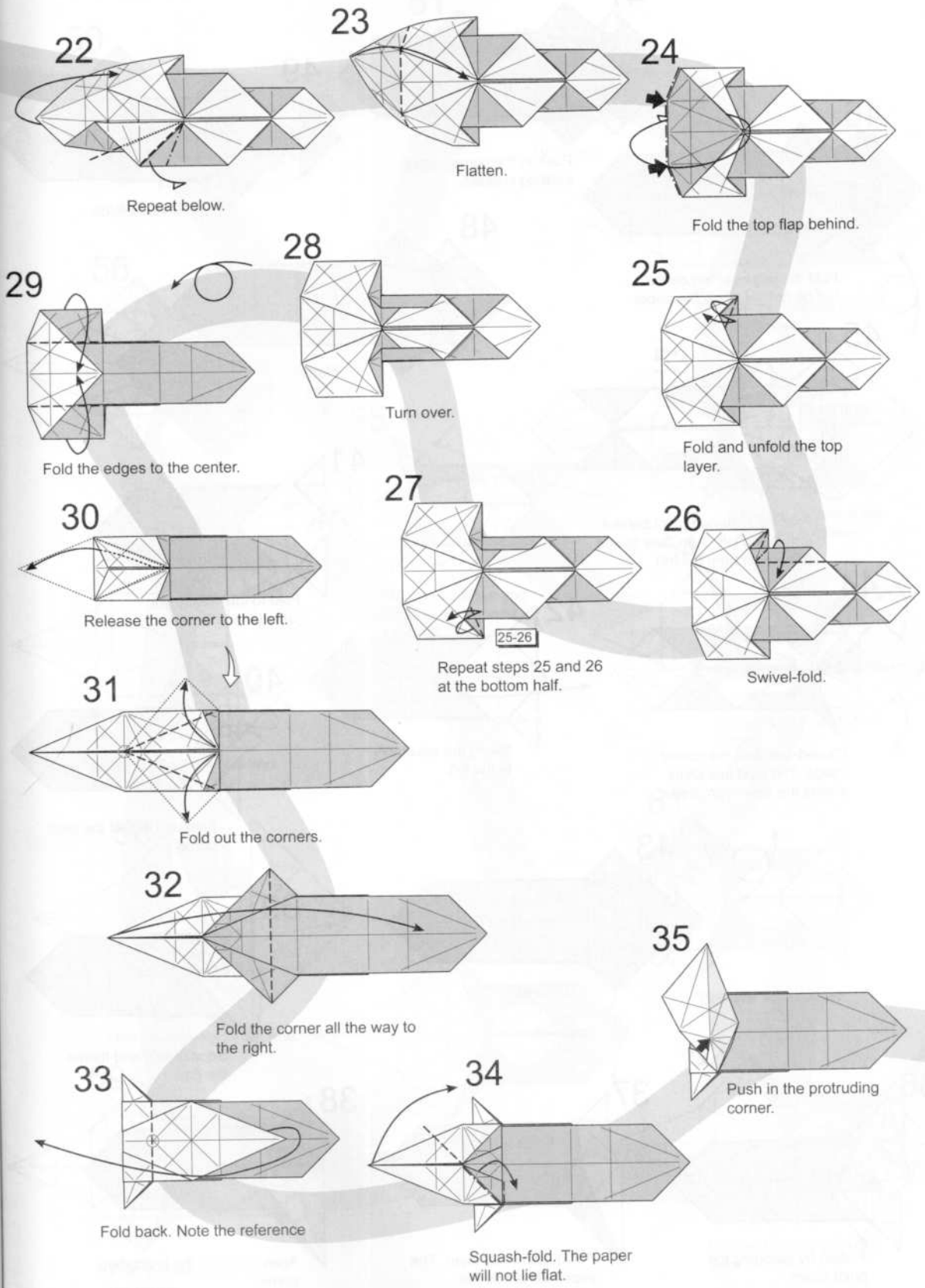

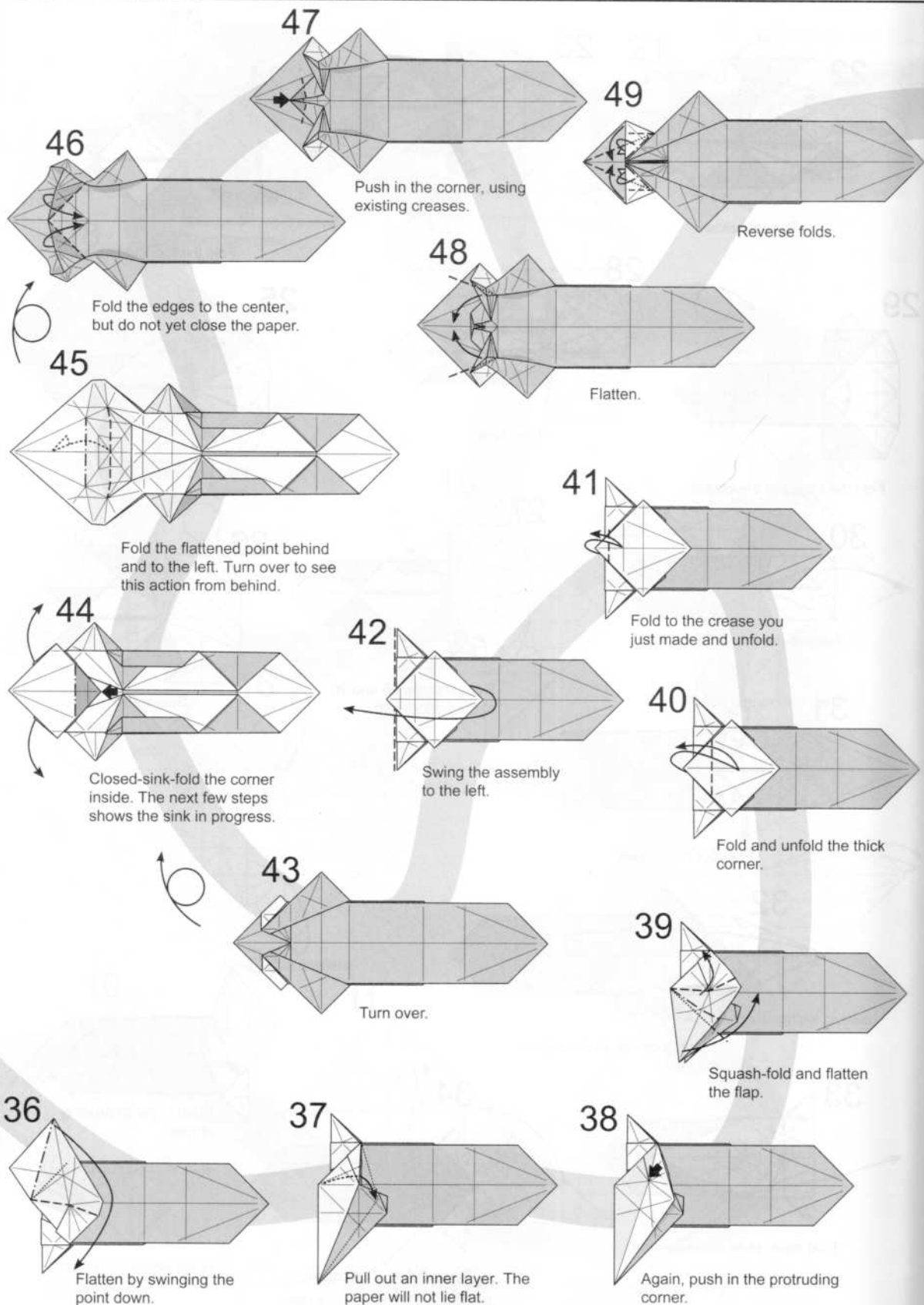

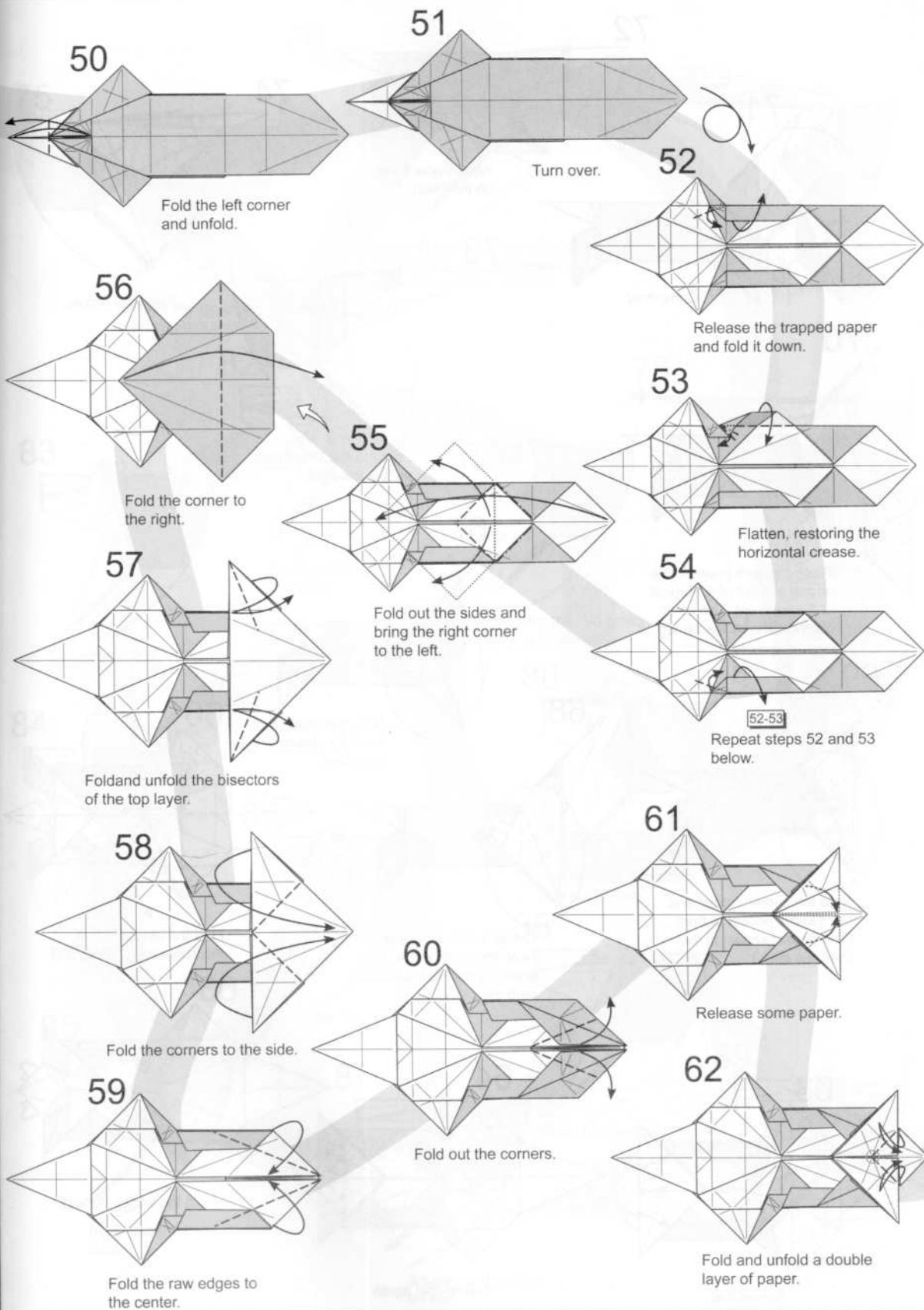

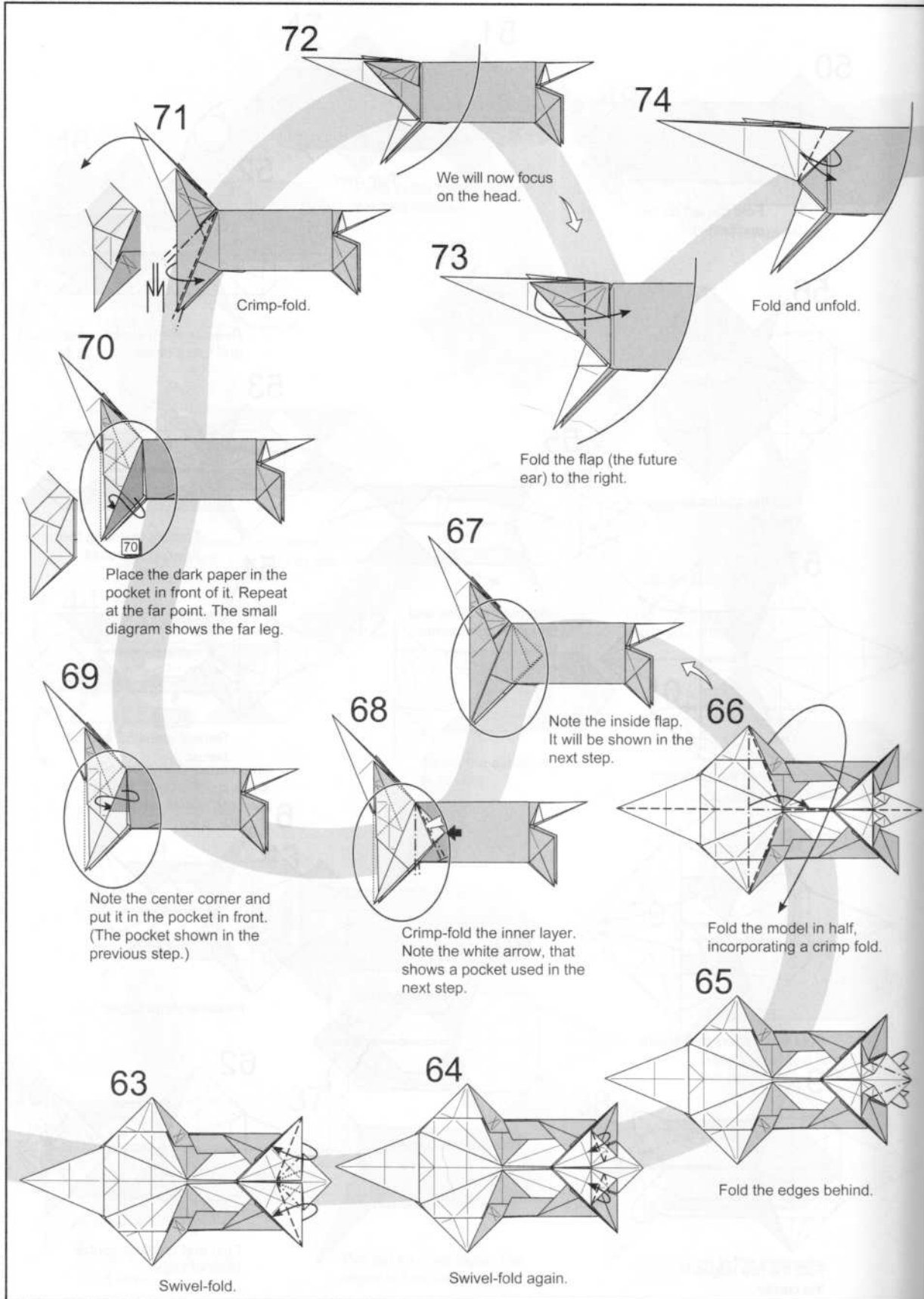

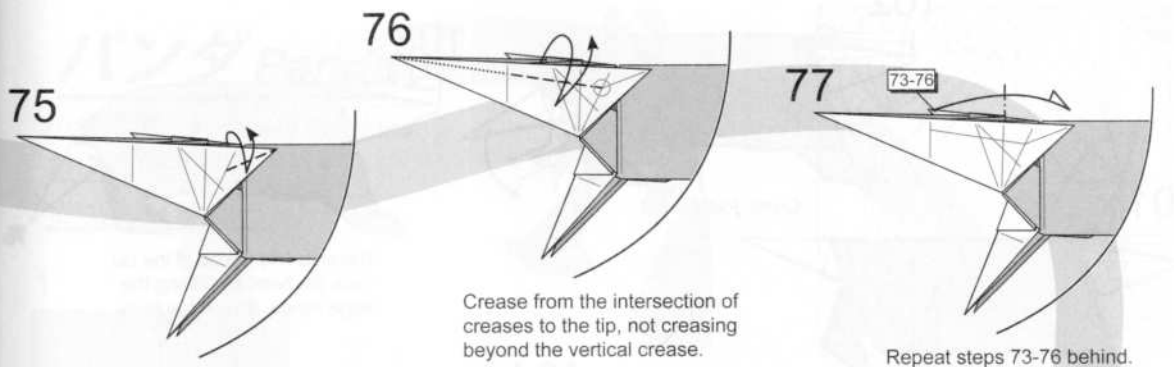

75
Crease the top layer, bisecting the angle.

76
Crease from the intersection of creases to the tip, not creasing beyond the vertical crease.

77
Repeat steps 73-76 behind.

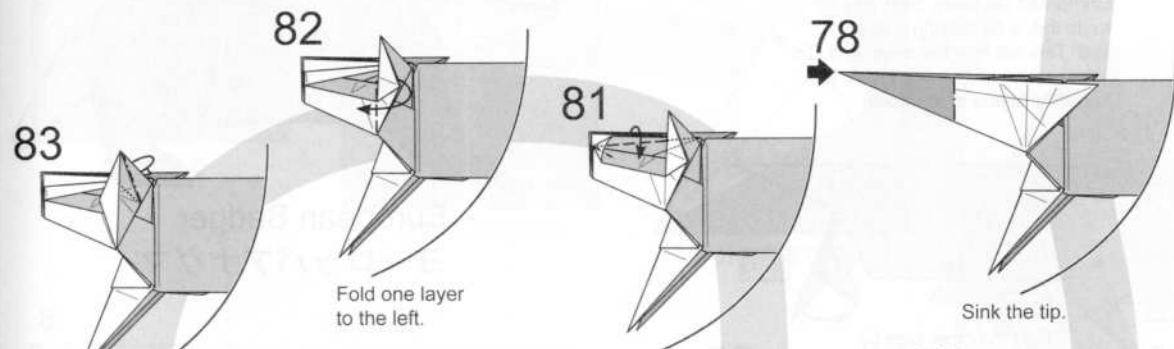

78
Sink the tip.

79
Reverse-fold.

80
Flatten, with the fold going all the way to the tip.

82
Fold one layer to the left.

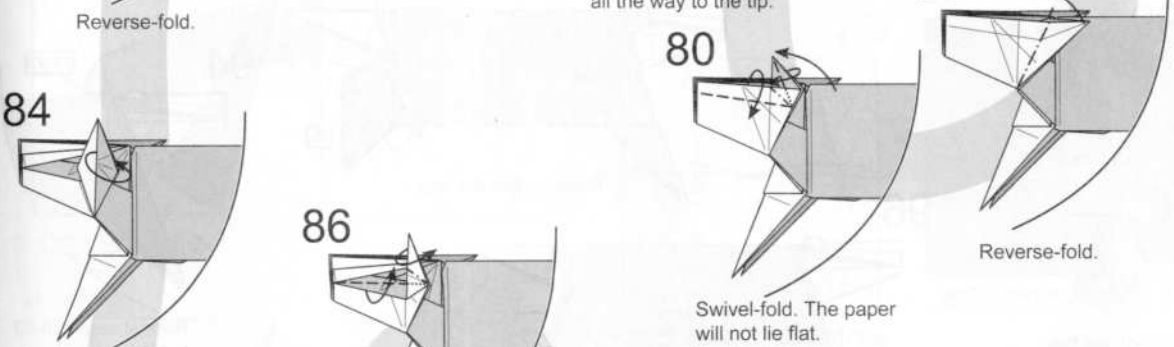

83
Reverse-fold.

84
Wrap two layers of paper around.

85
Book-fold the layer back.

86
Swivel-fold.

87
Swivel-fold. The paper will not lie flat.

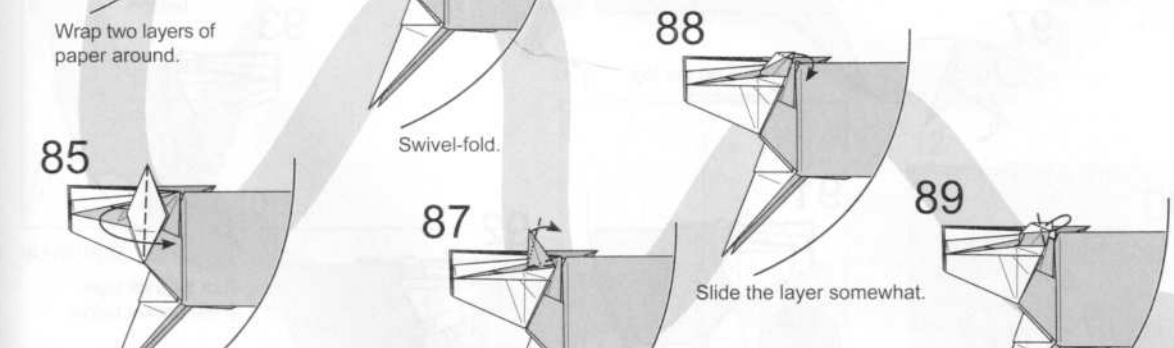

88
Slide the layer somewhat.

89
Shape the ear.

90
Squash-fold to form an ear.

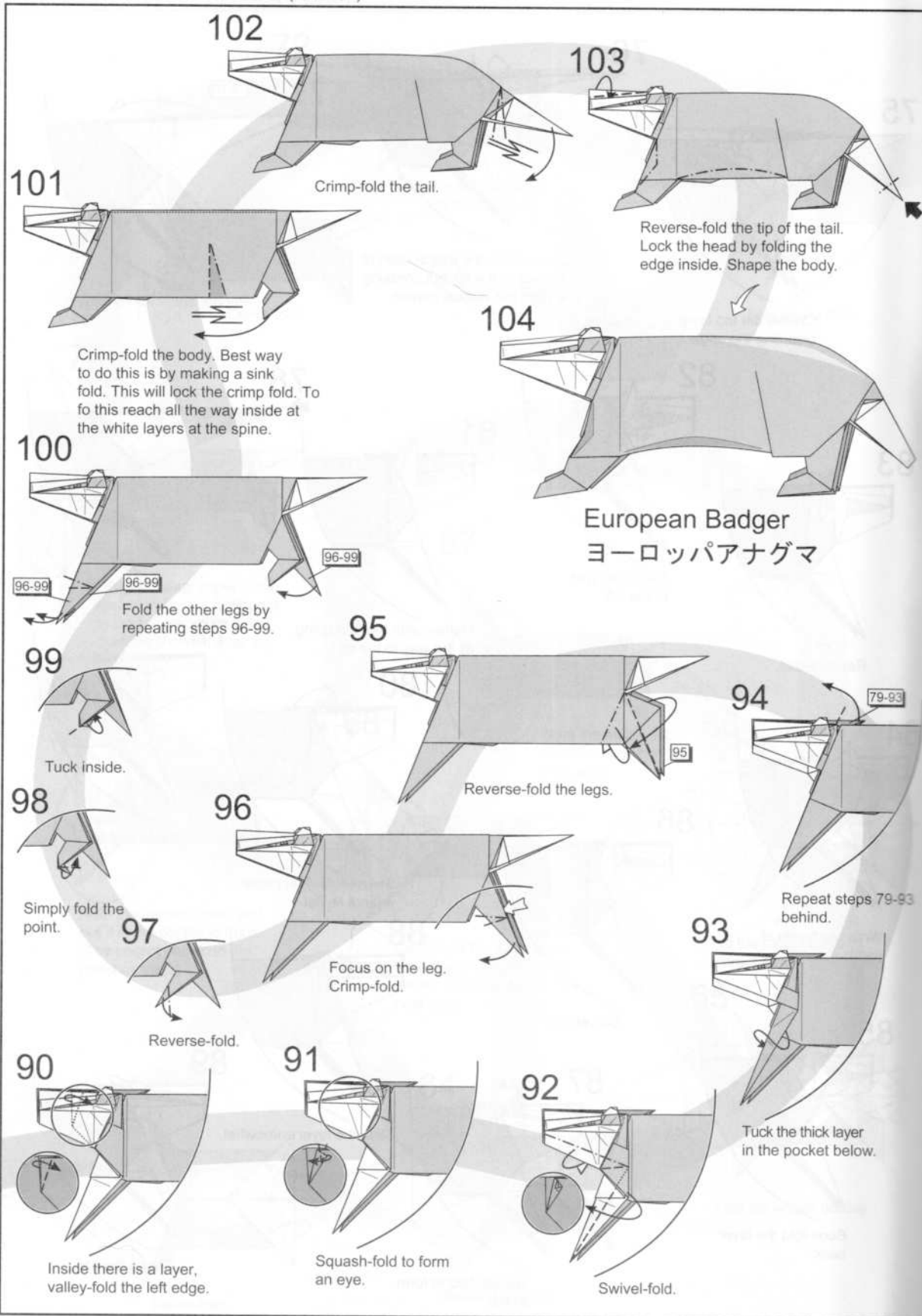

パンダ Panda

小橋清貴 Kobashi Kiyotaka

創作 2022/2

折り図 2024/5

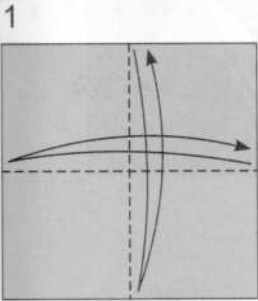
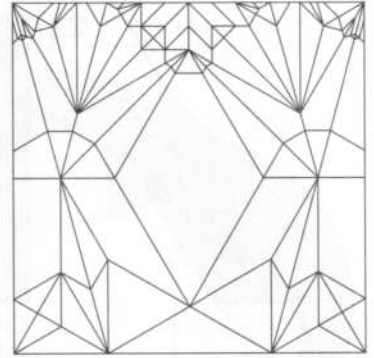

半分に折る

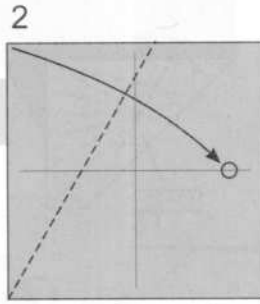

○に合わせて折る

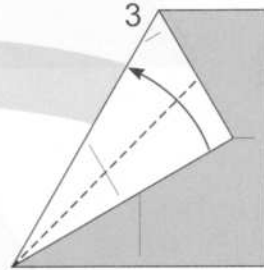

半分の角度で折る

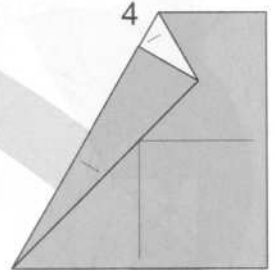

全て開く

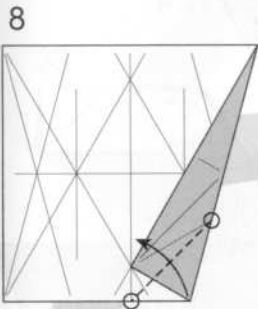

○を結ぶ線で折る

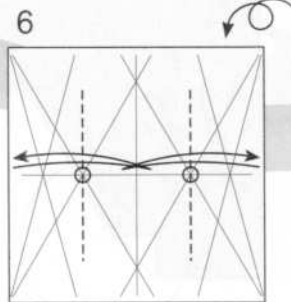
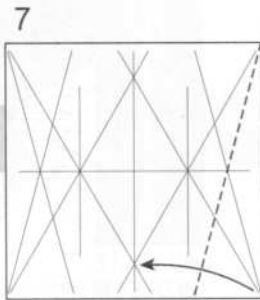

○を通る線で折り筋を付ける
(全部折らない)

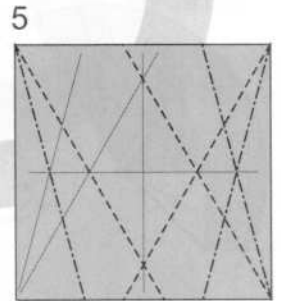

他の三か所も同様に折る

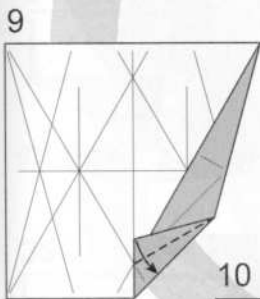

半分の角度で折る

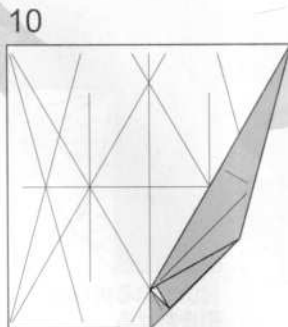

全部開く

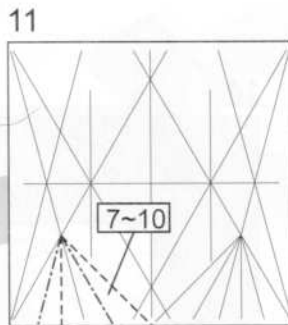

反対も同様に折る

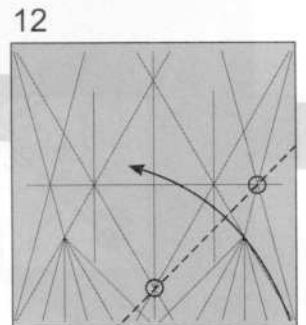

○を通る線で折る

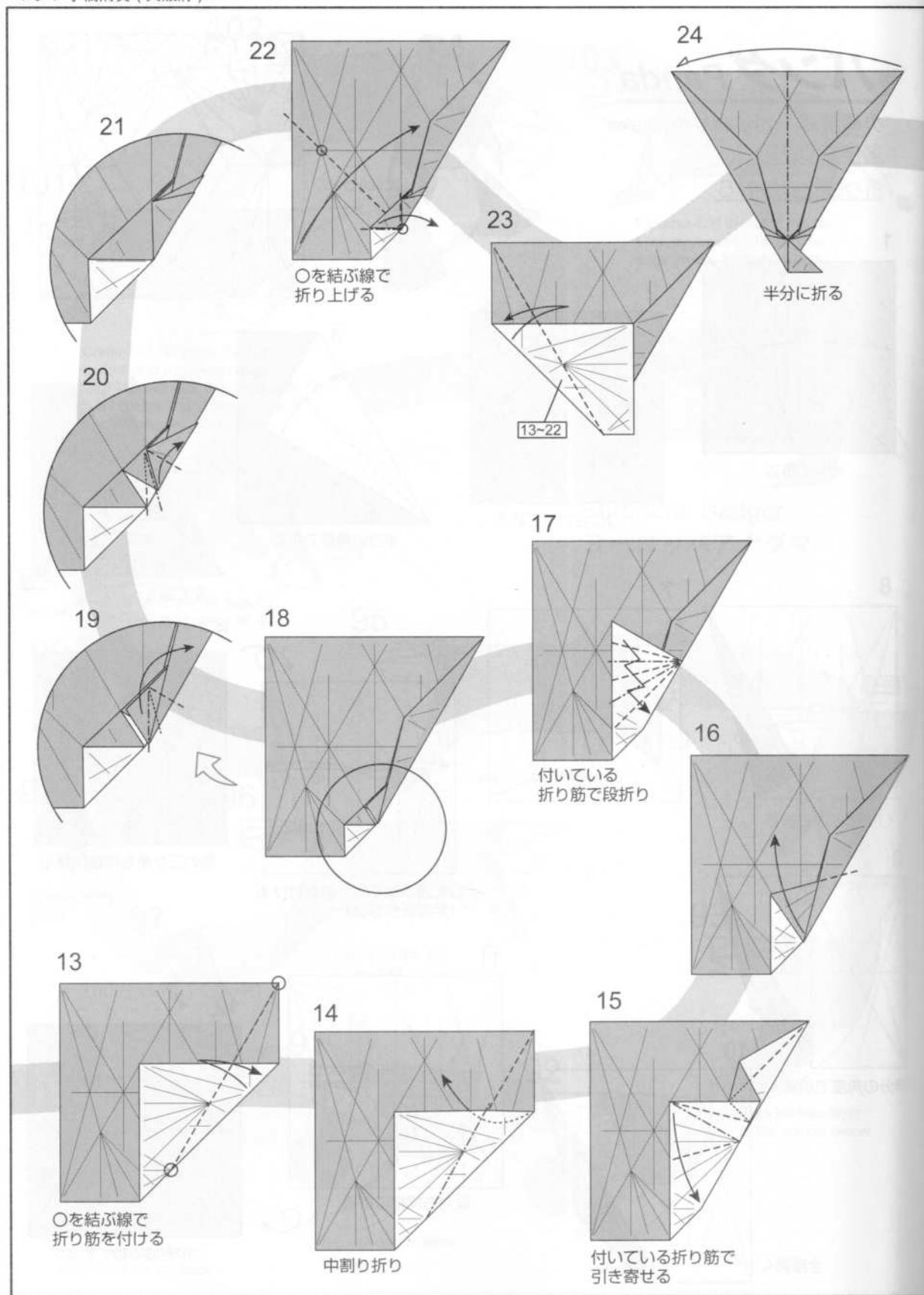

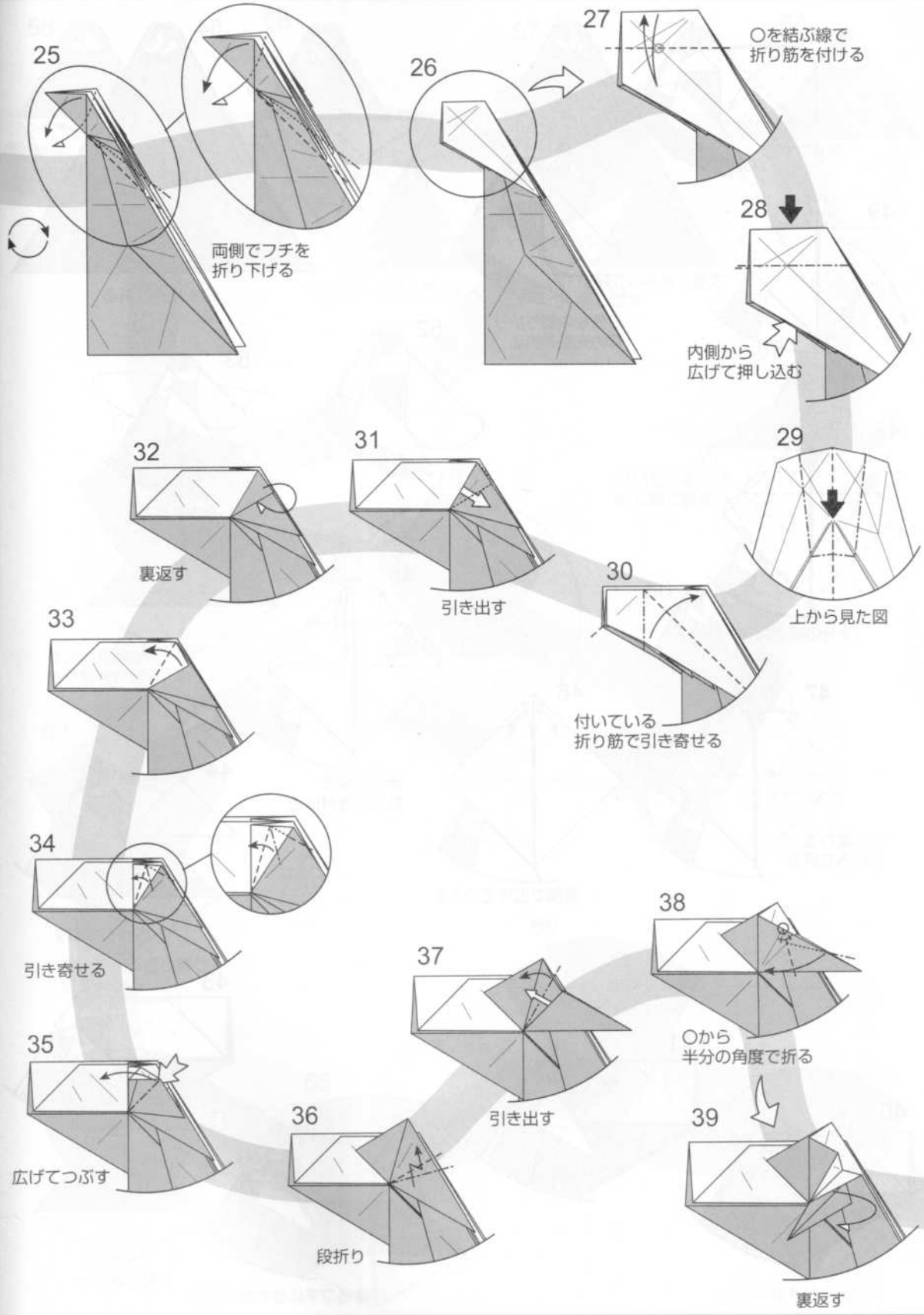

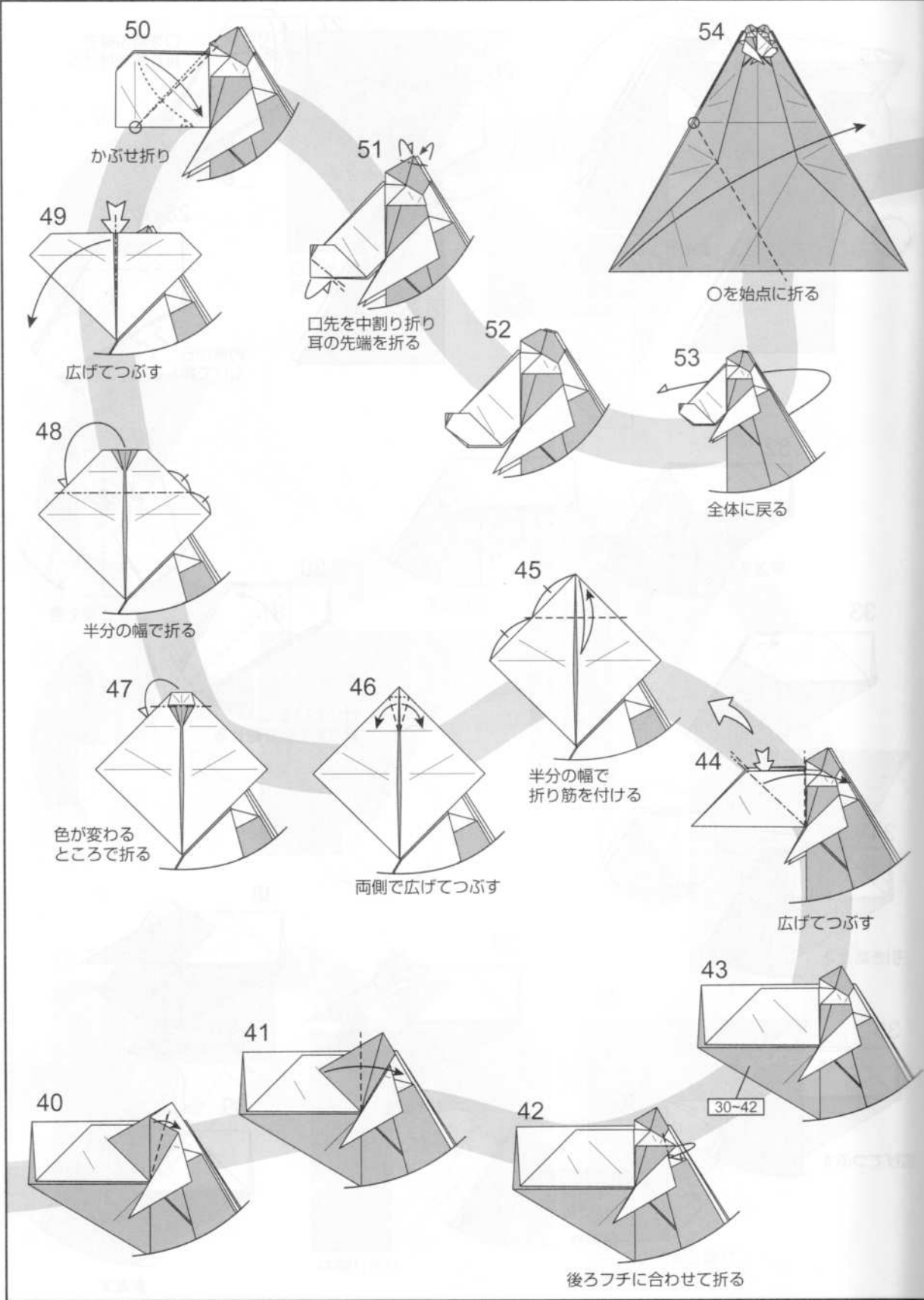

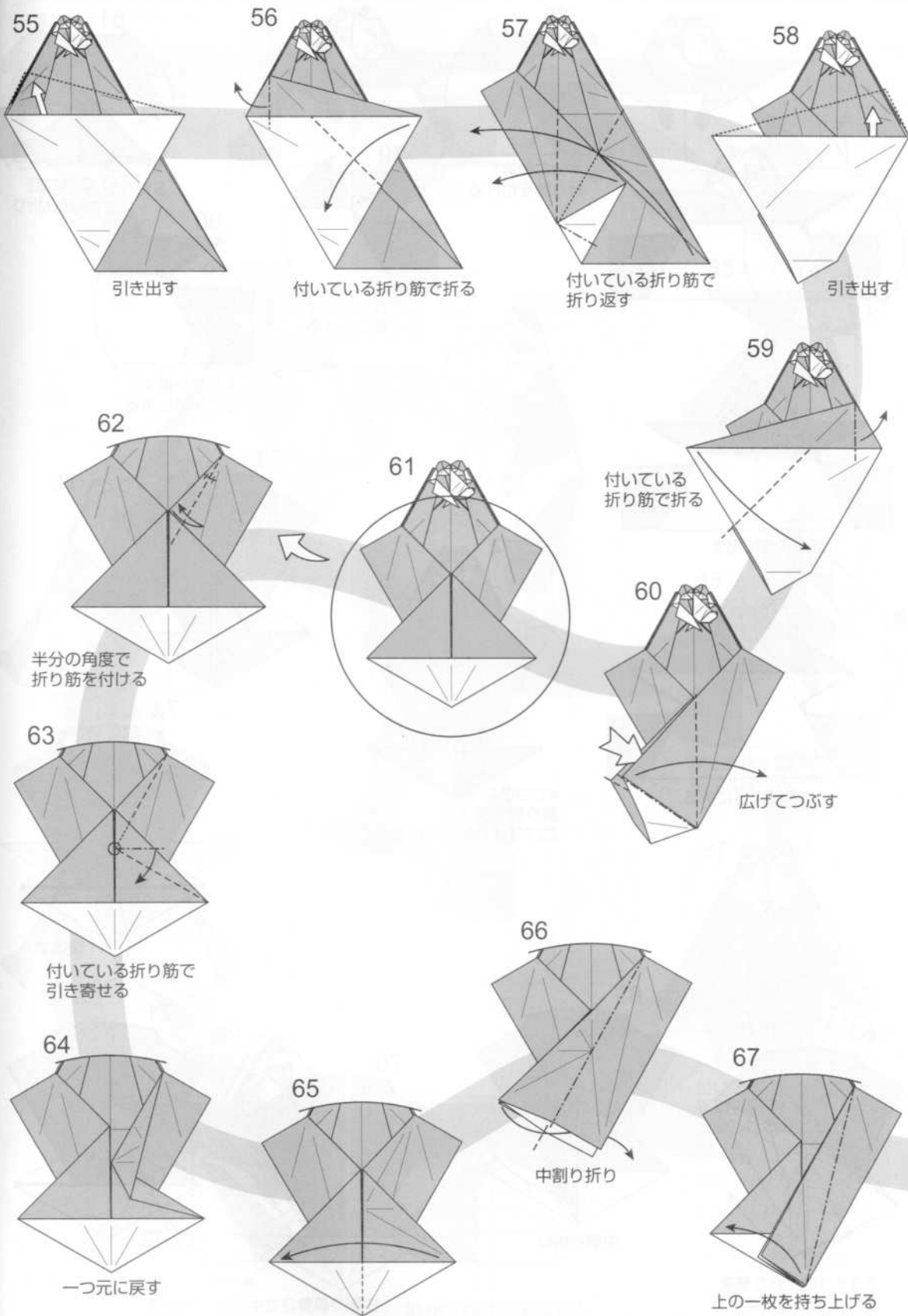

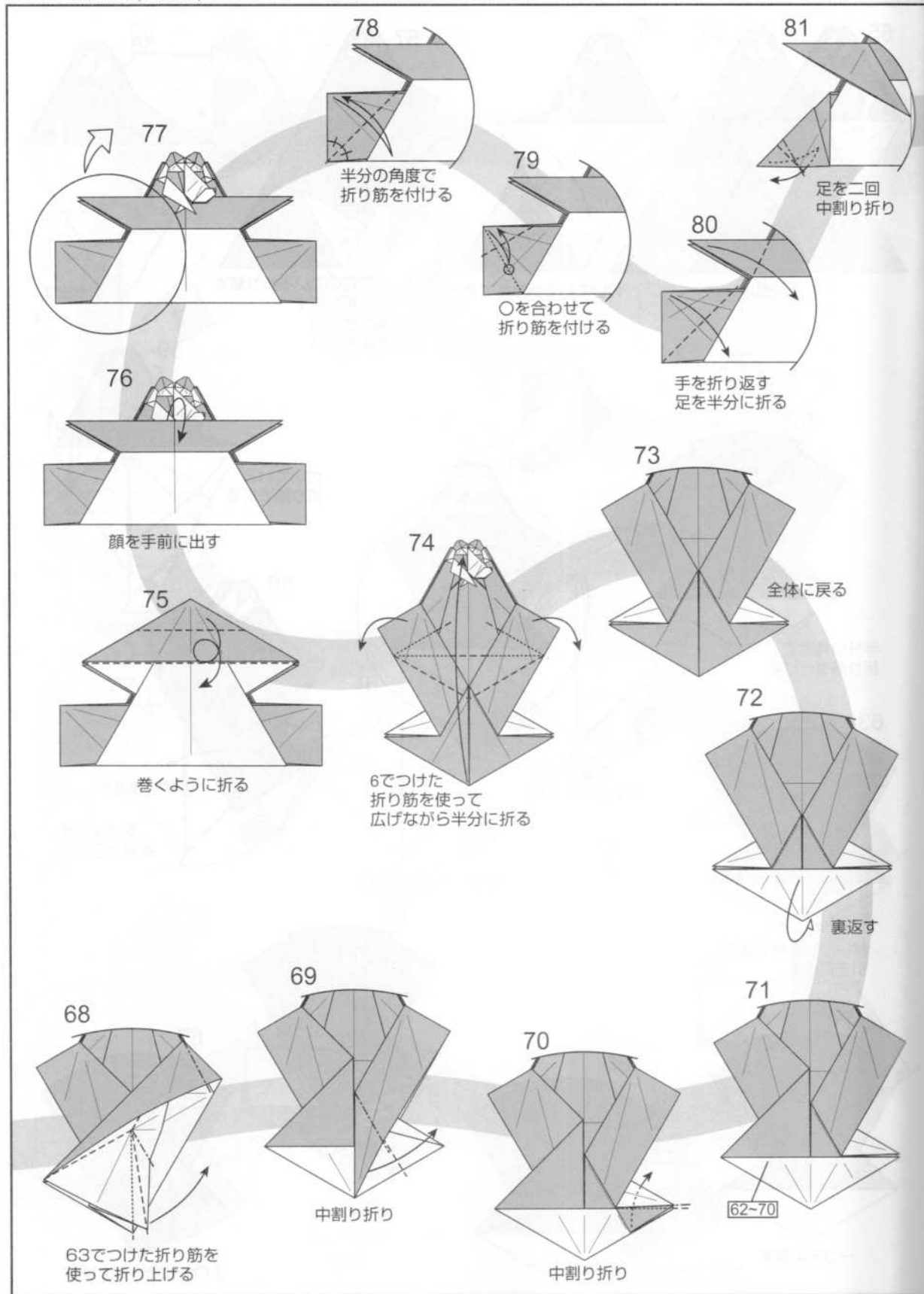

82

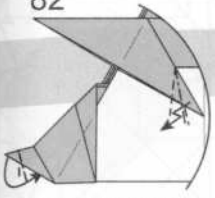

手先を広げて折る
足先を折る

83

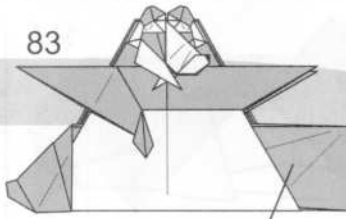

77-82

84

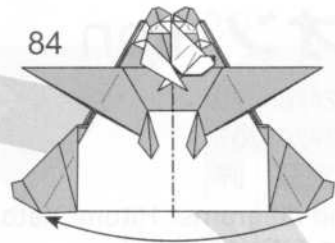

半分に折る

92

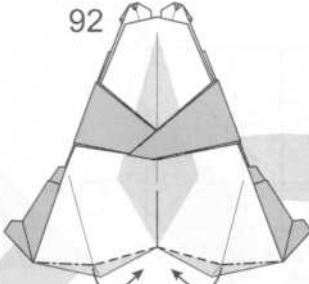

フチを折り込んで
自立するように
調節する

93



85

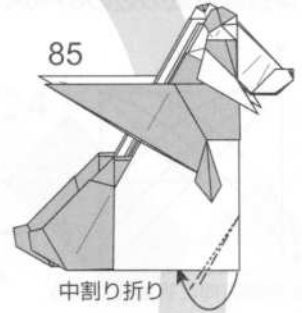

中割り折り

91



お互いの隙間に
差し込む

86

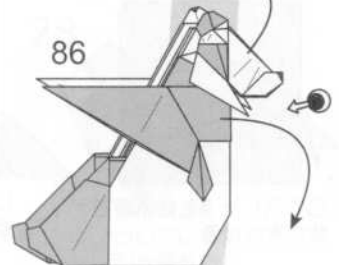

頭と身体を広げる、
視点を変える

90

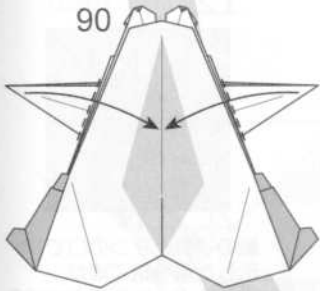

94



87

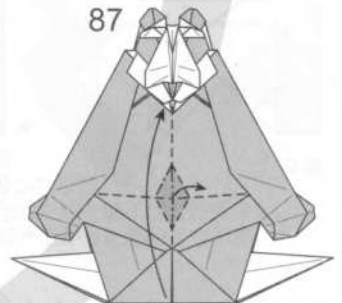

付いている折り筋で
留めるように折る
(難しければ省略可)

89

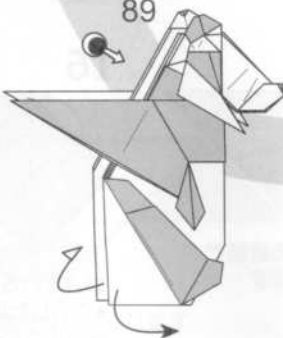

軽く開いて背中から見る

88

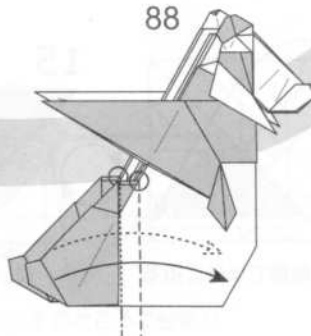

足の付け根から前に折る

ライオン lion

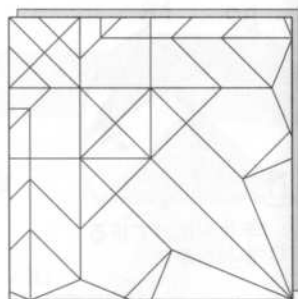
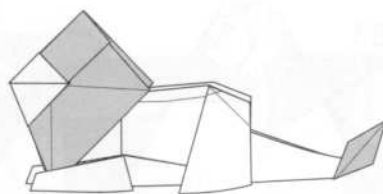

創作：2024/04/29

作図：2024/05/05

作/図：加藤 眸

Model and diagrams: Hitomi Kato

推奨用紙サイズ：15cm以上

体長は用紙の辺の67%くらいになります

1

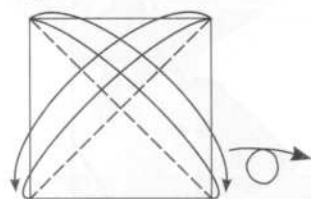

対角線方向に折筋をつける

2

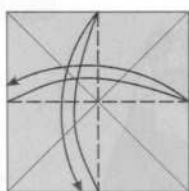

縦横に折筋をつける

3

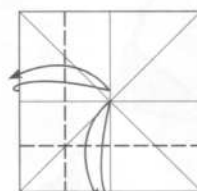

辺が縦横の折筋に合うように折筋をつける

4

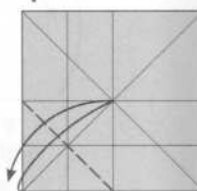

中心に合わせて折筋をつける

5

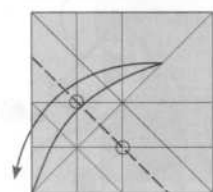

○で示した点を結ぶ線で折筋を付ける

6

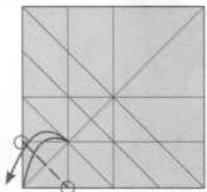

○で示した点を結ぶ線で折筋を付ける

7

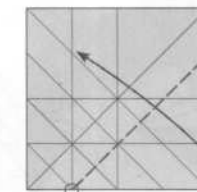

○で示した点を基準に谷折り

8

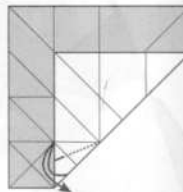

角を2等分する位置で印をつける

9

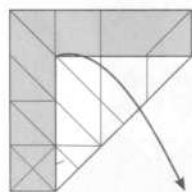

開く

10

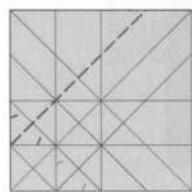

反対側も7-9と同様に折筋をつける

11

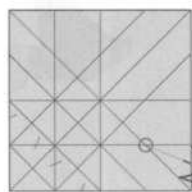

○のところを始点として角を2等分する位置で印をつける

12

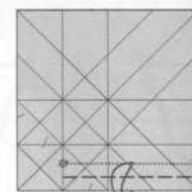

紙のフチと2つの○で示した点を結ぶ線が重なるように折筋をつける

13



反対側も同様に折筋を付ける

14

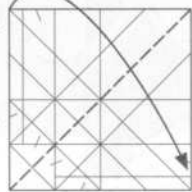

対角線で半分にする

15

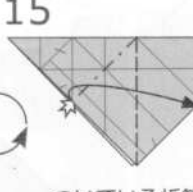

ついている折筋で開いてつぶす

16

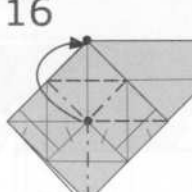

ついている折筋を使い
●で示した頂点同士が合うように折筋をつける

17

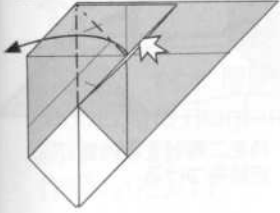

ついている折筋を使って開いてつぶす

18

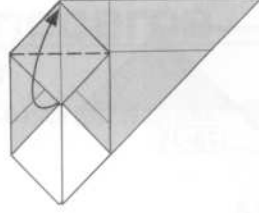

ついている折筋で開く

19

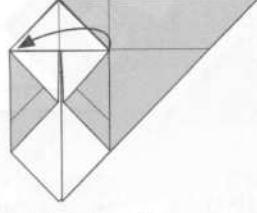

開くところで折る

20

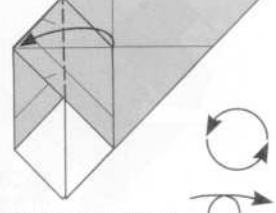

開くところで折る

21

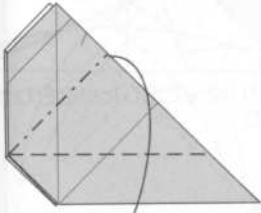

ついている折筋で開いてつぶす

22

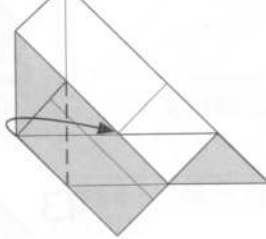

開くところで折る
(ずれやすいので注意)

23



反対側も
21-22と同様に折る

24

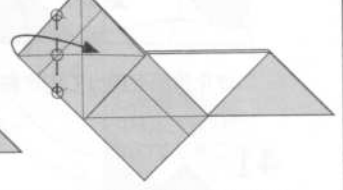

3つの○で囲った部分を
結ぶ線で谷折りする

25

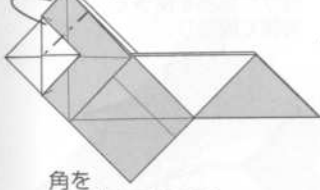

角を
二等分する角度で
山折り

26

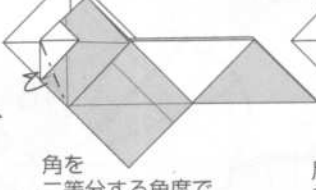

角を
二等分する角度で
山折り

27



反対側も
24-26と同様に折る

28

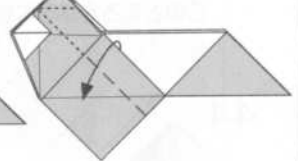

ついている折筋で
引き寄せ折り

29

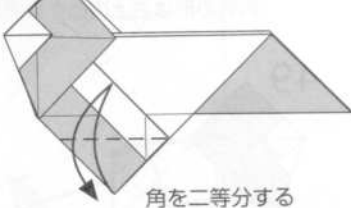

角を二等分する
角度で谷折り

30

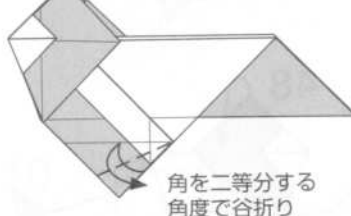

角を二等分する
角度で谷折り

31

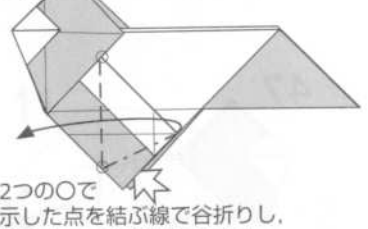

2つの○で
示した点を結ぶ線で谷折りし、
起き上がった部分をつぶす

32

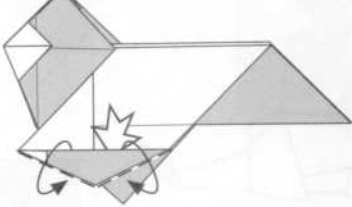

三角形の部分をひっくり返す
ように折る

33

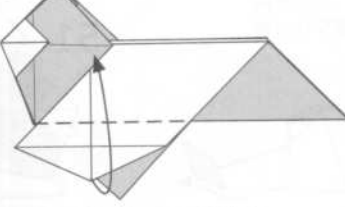

下のフチのところで谷折り

34

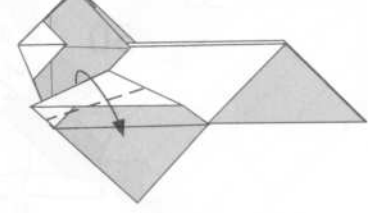

太線で示したフチ同士が
合うように谷折り

35

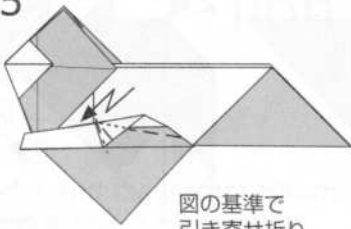

図の基準で
引き寄せ折り

36

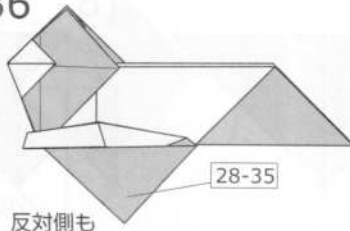

反対側も
28-35と同様に折る

37

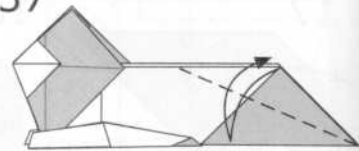

角を二等分する角度で
折筋をつける

38

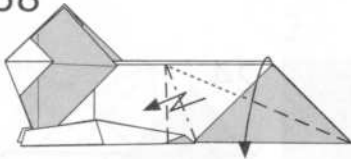

つけた折筋を使って引き寄せ折り

39

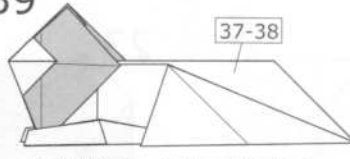

反対側も37-38と同様に折る

40

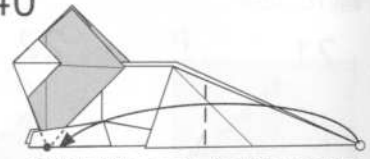

○のカドと●で示した点を合わせて
谷折り

41

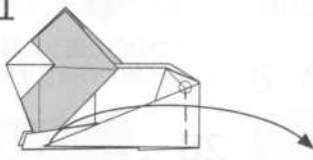

○のところを基準に谷折り

42

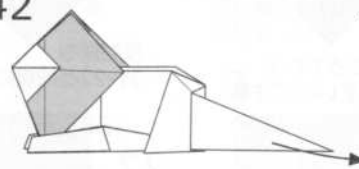

40の形に戻す

43

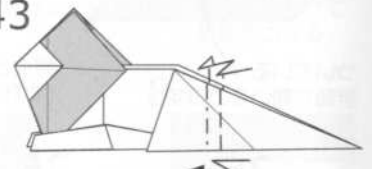

付けた折筋を使って
両側で段折り

44

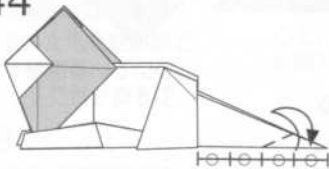

図の基準で折筋を付ける

45

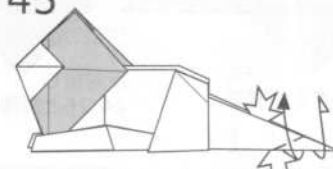

つけた折筋で立体的に
かぶせ折り

46

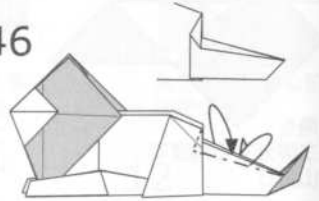

尾を細く折り込む
根元の部分は引き寄せ折り
(内側の形は右上の図を参考に)

47

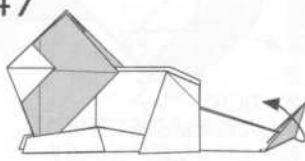

開く

48

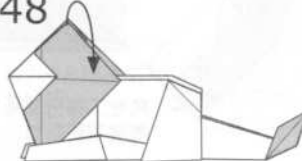

頭を少し開く
平らにはならない

49

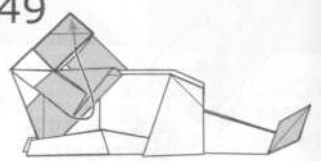

太線で示した台形の部分に
48で開いたカドを差し込む
(留め折り)

50

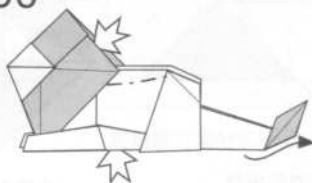

各部を立体的に整える

51

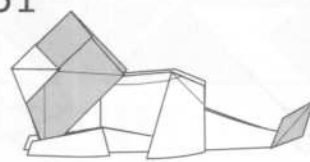

できあがり

サイ Rhinoceros

作/図 村木厚紀

Model and diagrams: Atsunori Muraki

創作:2023/7

作図:2023/11

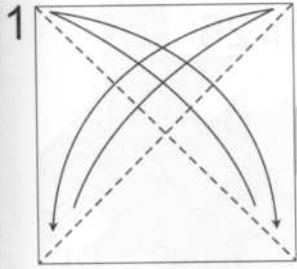
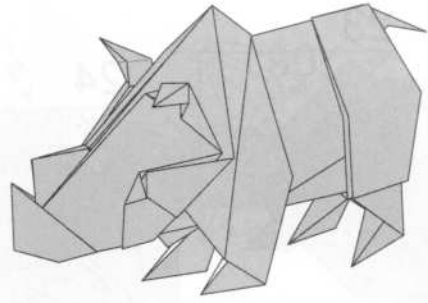

1 対角線に折りすじをつける

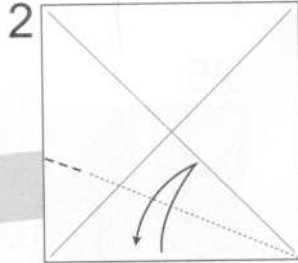

2 フチを中心に合わせて折り印をつける

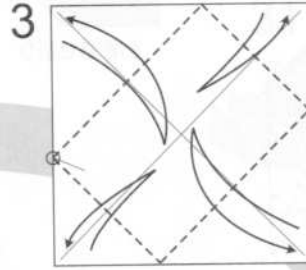

3 ○を基準に中心に合わせて折りすじをつける

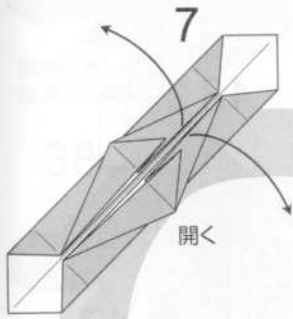

4 開く

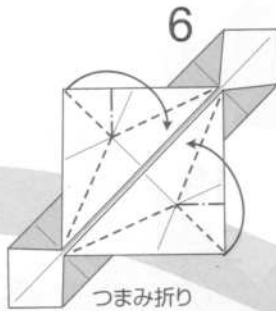

5 つまみ折り

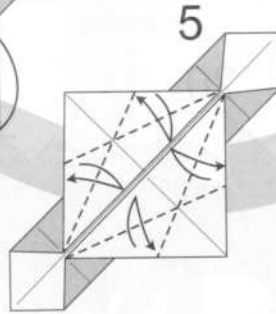

6

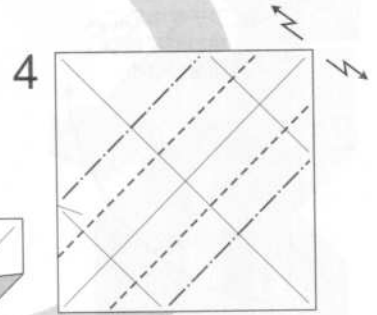

7 折りすじを合わせて段折り

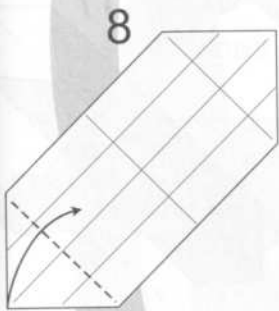

8

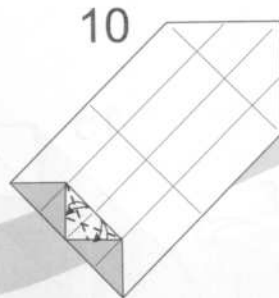

9

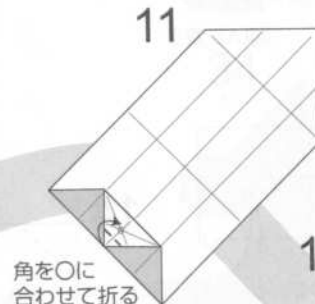

10 角を○に合わせて折る

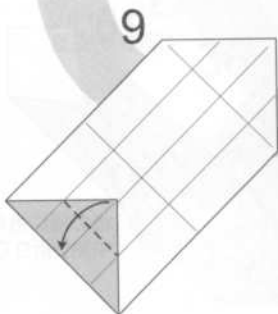

11

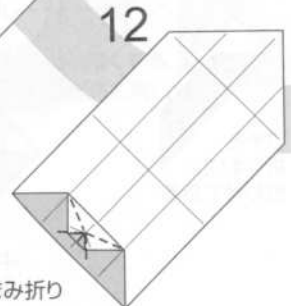

12

12 フチとフチを合わせて折る

つまみ折り

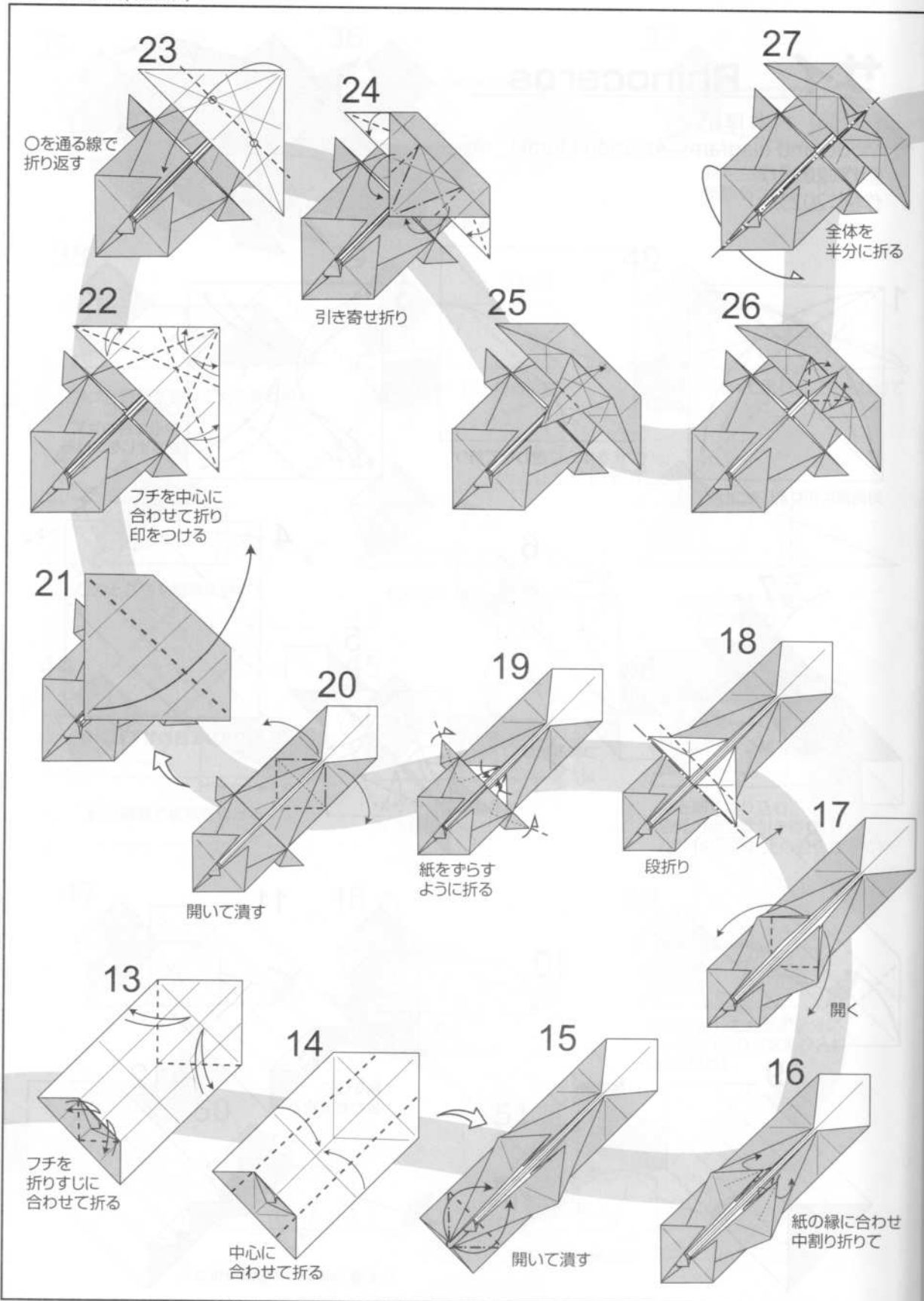

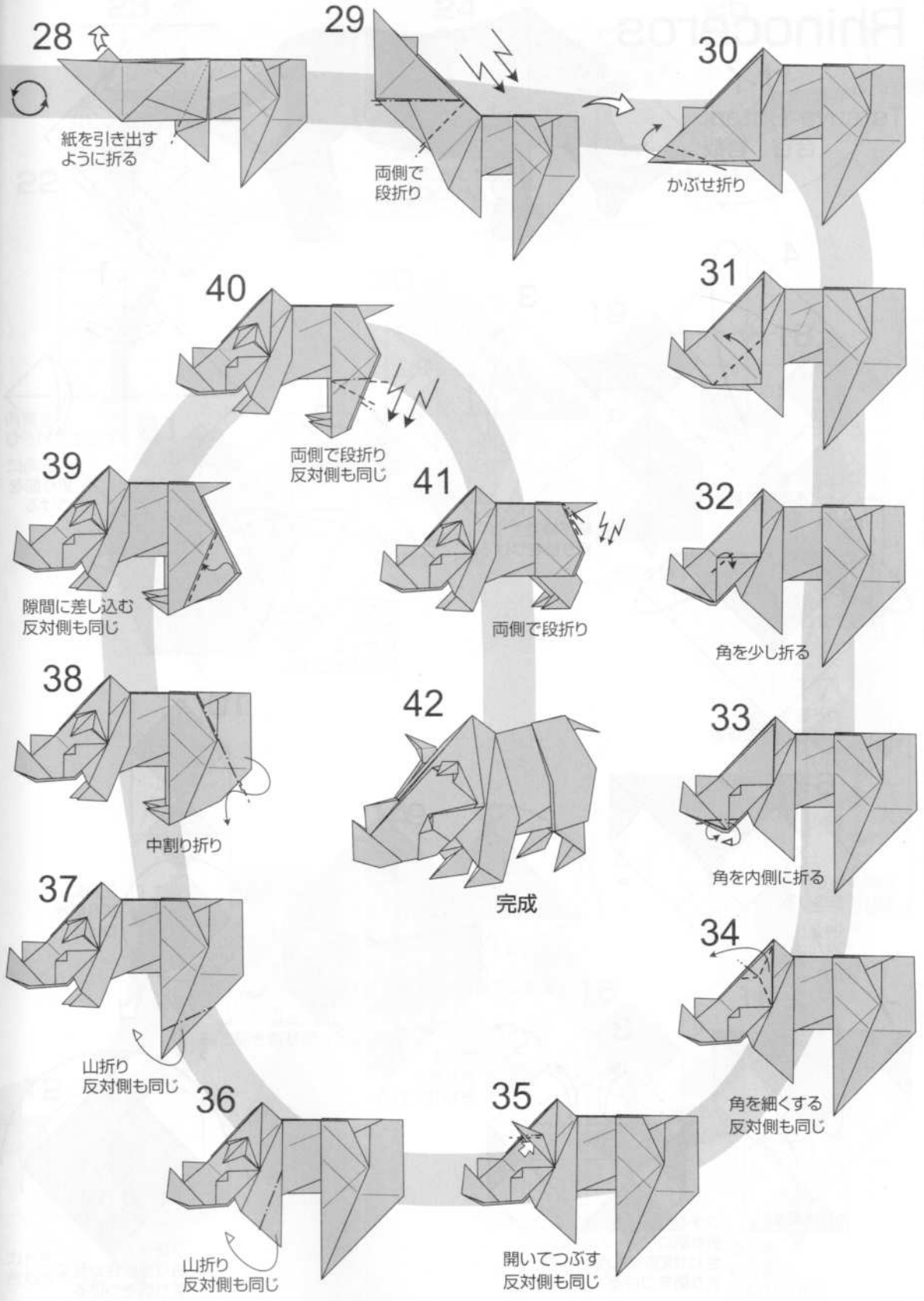

Rhinoceros

サイ

Tetsuya Gotani
合谷 哲哉

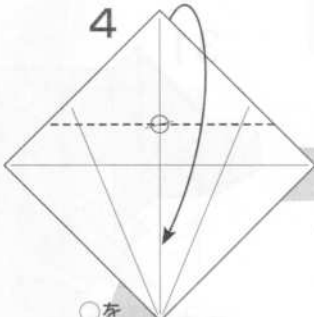
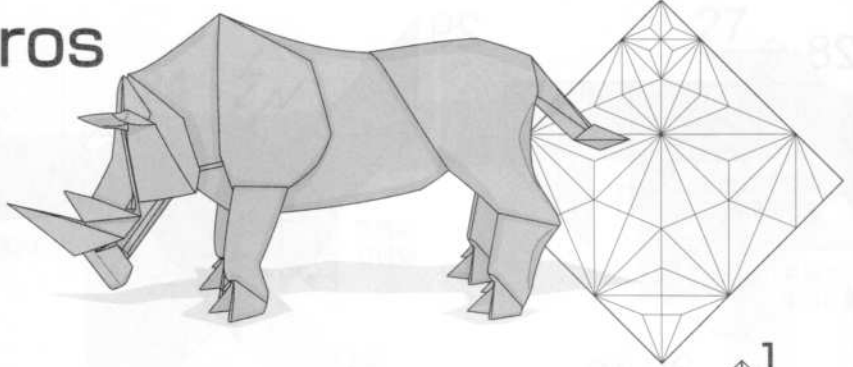

○を
通る線で折る



○を
結ぶ線で
折り筋をつける

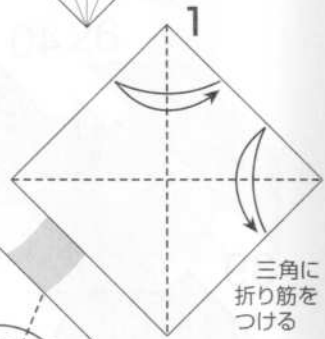

三角に
折り筋を
つける

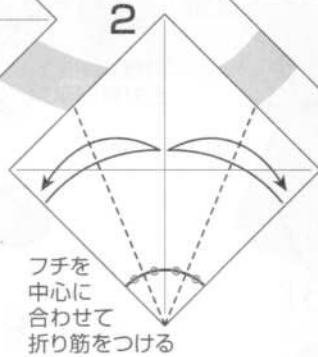

フチを
中心に
合わせて
折り筋をつける

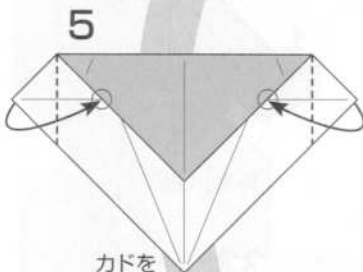

カドを
○に合わせて折る

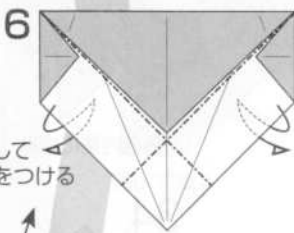

山折りして
折り筋をつける

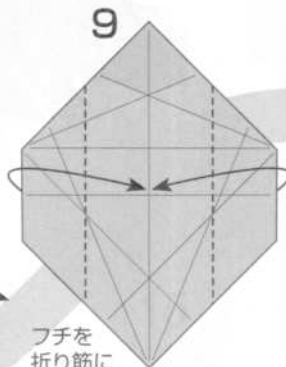

フチを
折り筋に
合わせて折る

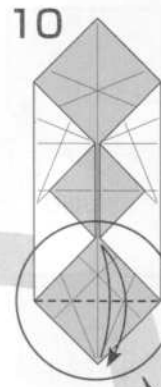

三角に
折り筋を
つける

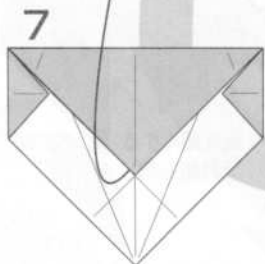

カドを戻す

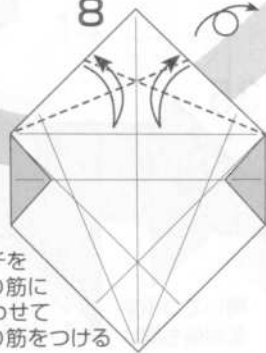

フチを
折り筋に
合わせて
折り筋をつける

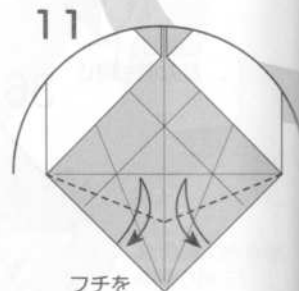

フチを
折り筋に
合わせて
折り筋をつける

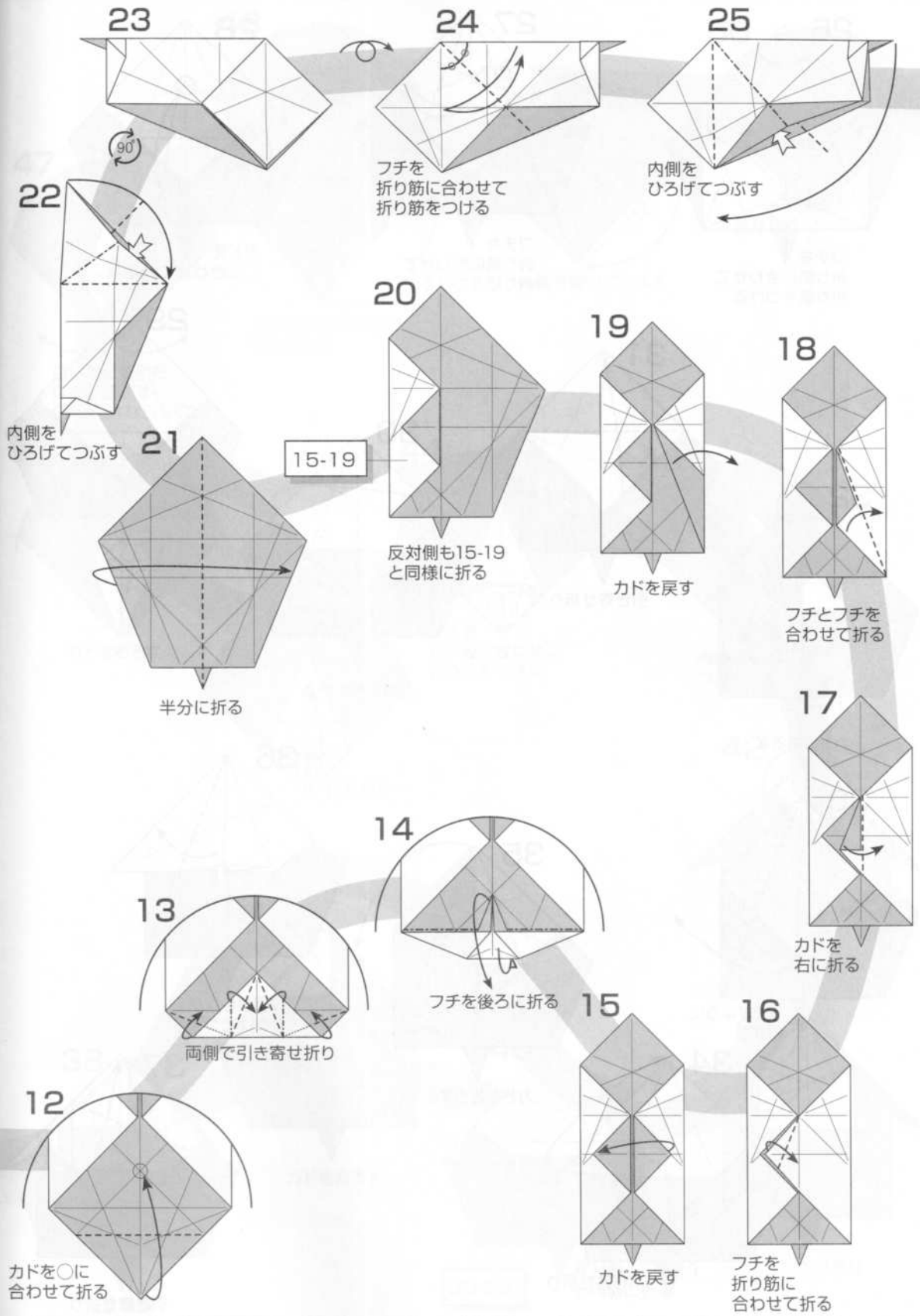

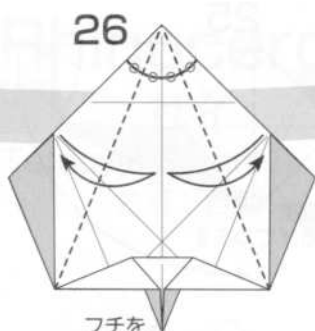

26
フチを
折り筋に合わせて
折り筋をつける

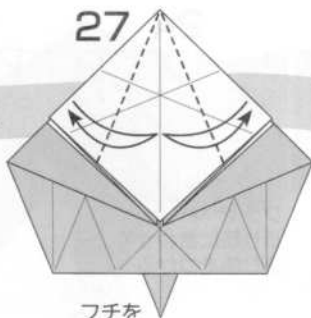

27
フチを
折り筋に合わせて
折り筋をつける

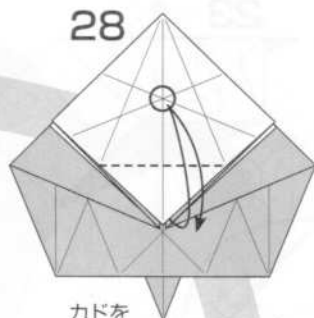

28
カドを
○に合わせて折る

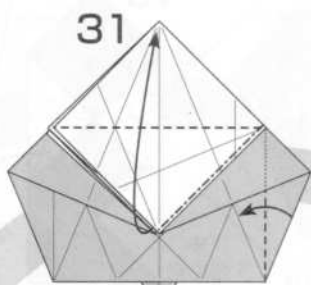

31
引き寄せ折り

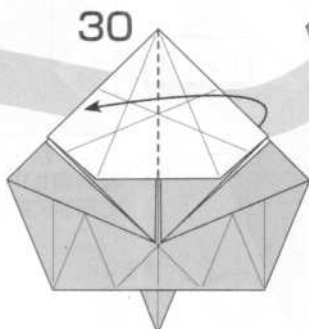

30
カド右に折る

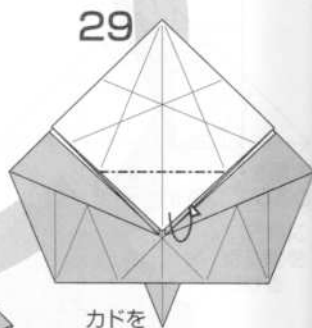

29
カドを
後ろに折る

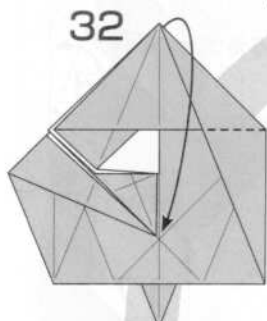

32
カドをおろす

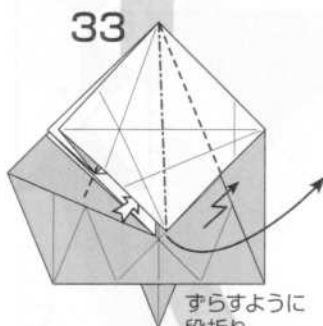

33
ずらすように
段折り

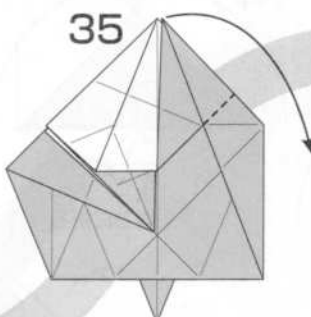

35
カドをおろす

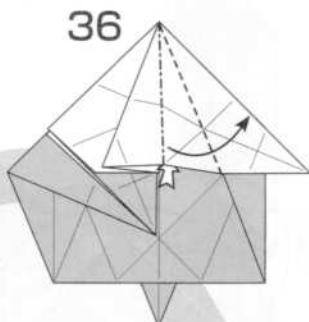

36
段折りしながら
ひろげてつぶす

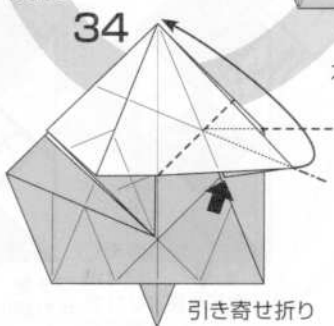

34
引き寄せ折り

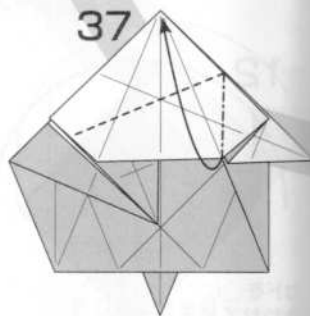

37
引き寄せ折り

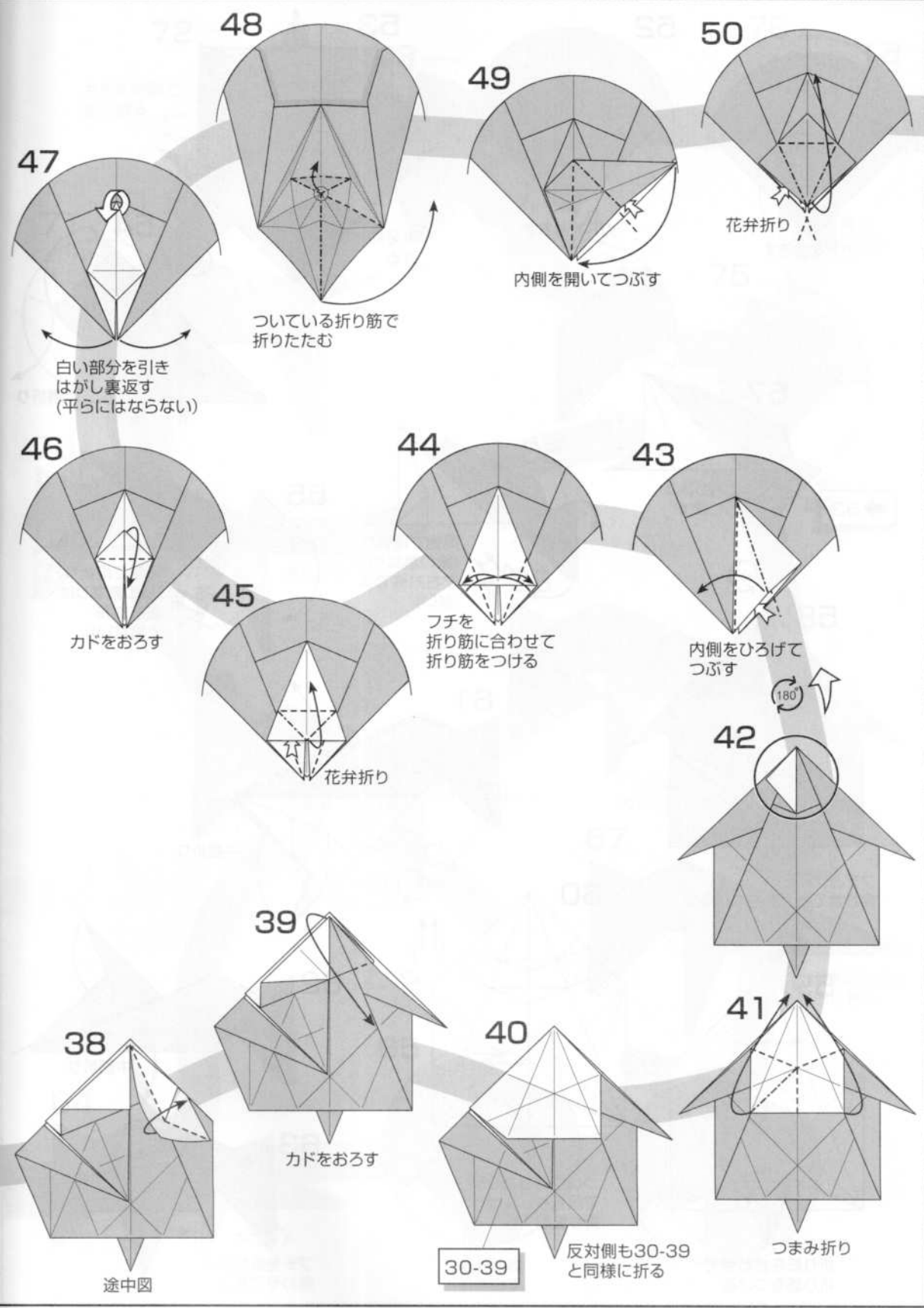

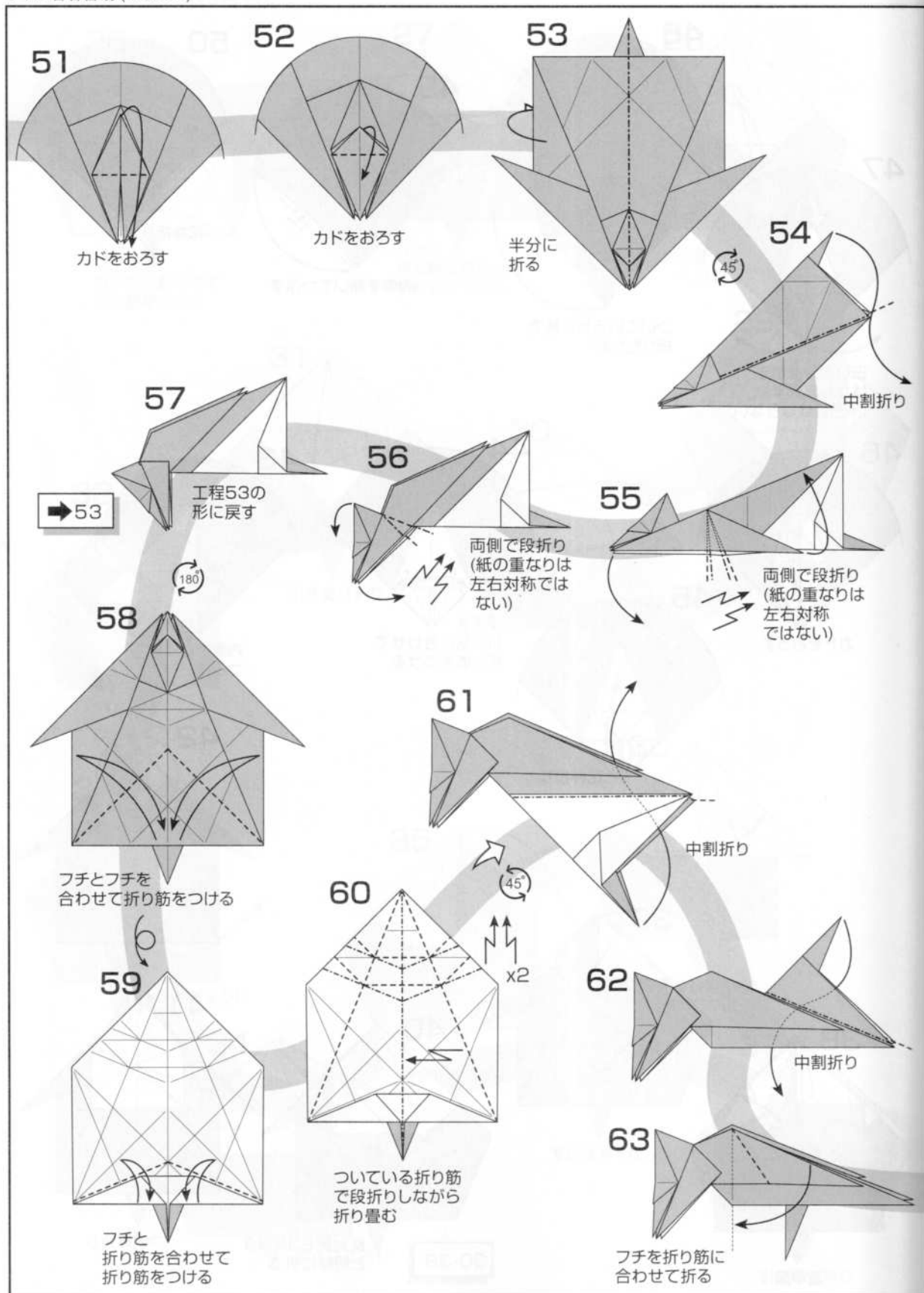

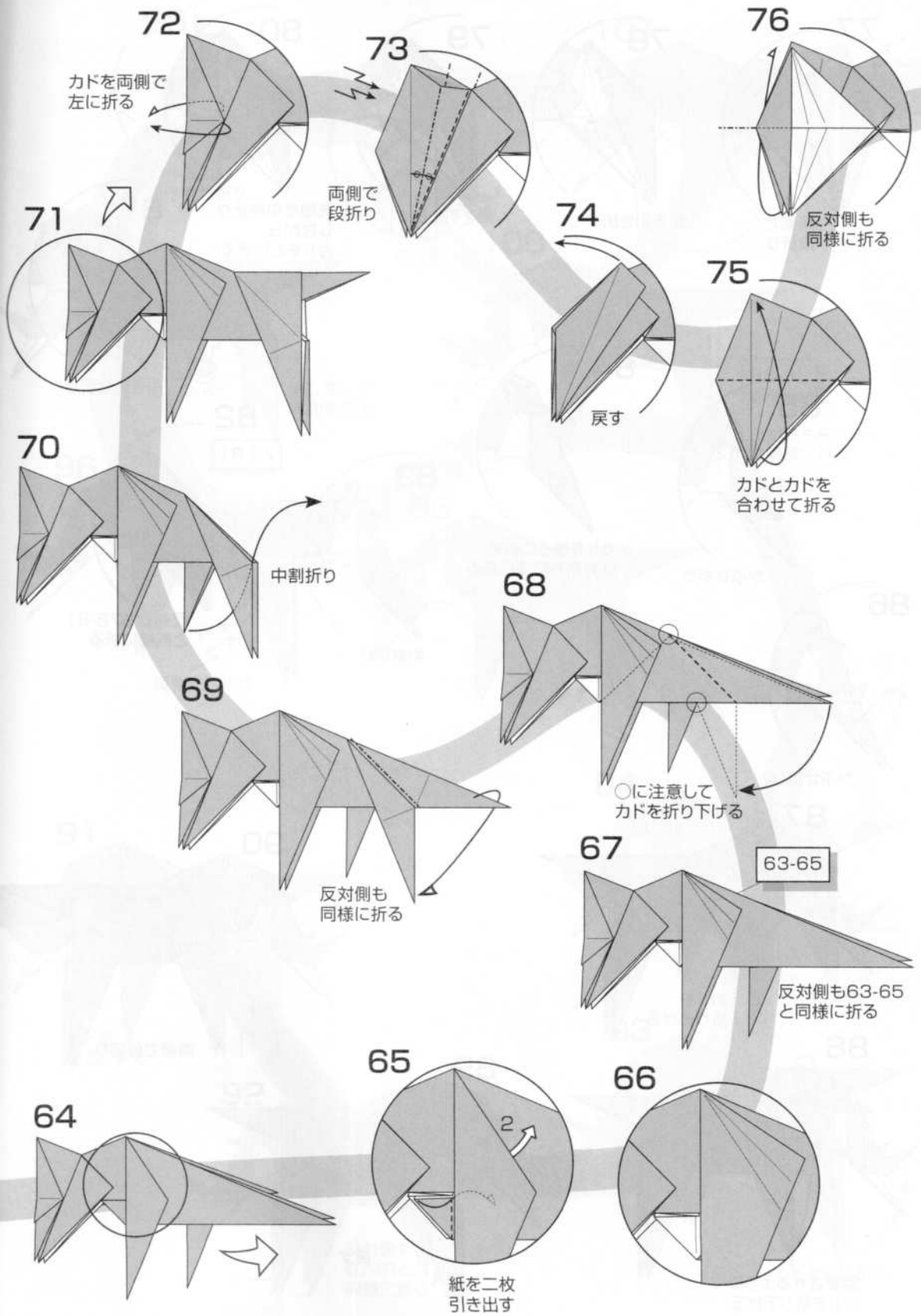

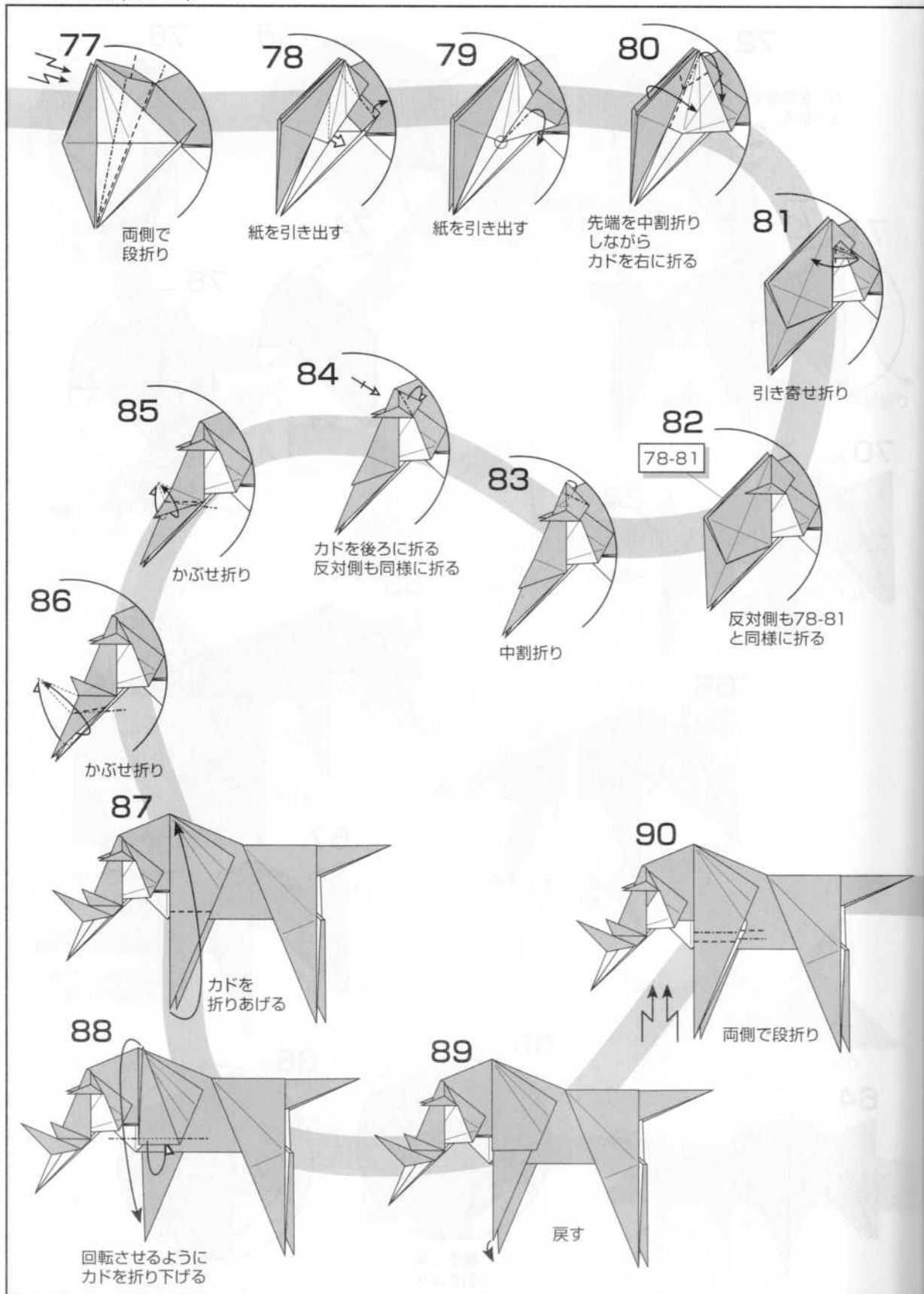

98

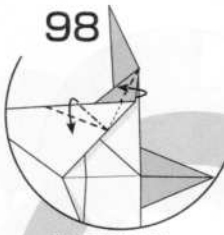

引き寄せ折り

99

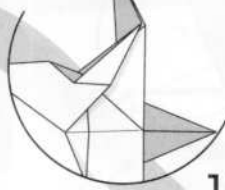

閉じる

101

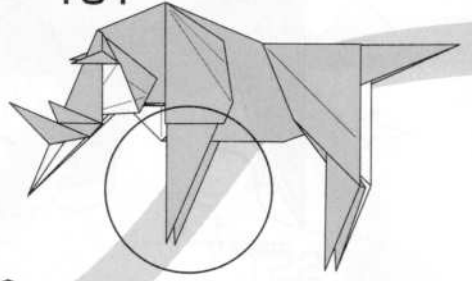

97

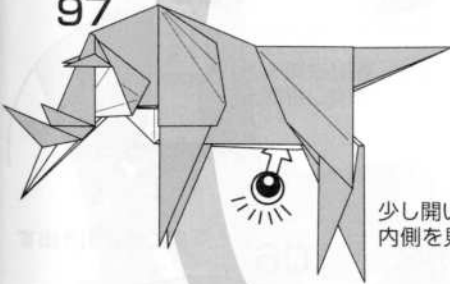

少し開いて
内側を見る

100

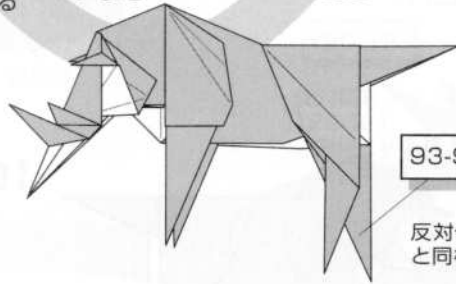

93-99

反対側も93-99
と同様に折る

96

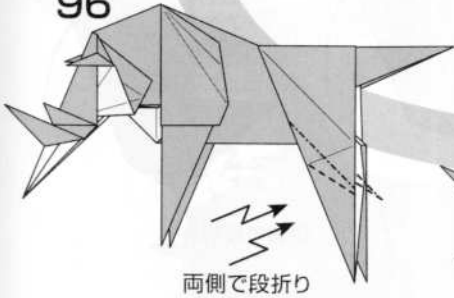

両側で段折り

95

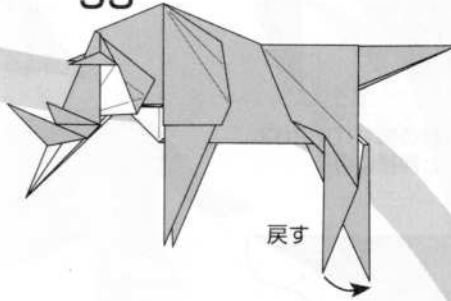

戻す

94

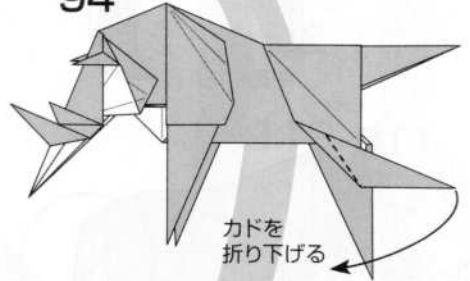

カドを
折り下げる

91

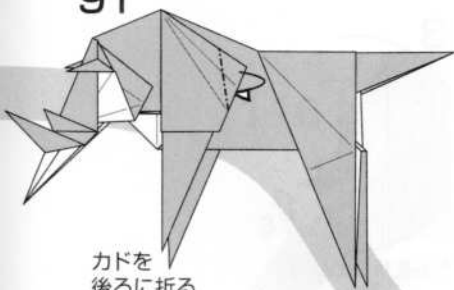

カドを
後ろに折る

93

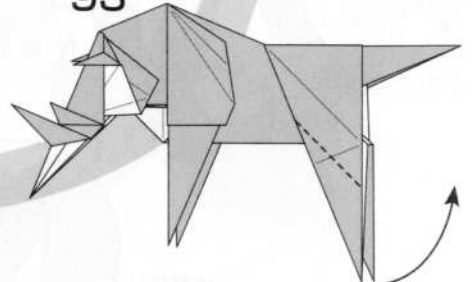

カドを右に折る

92

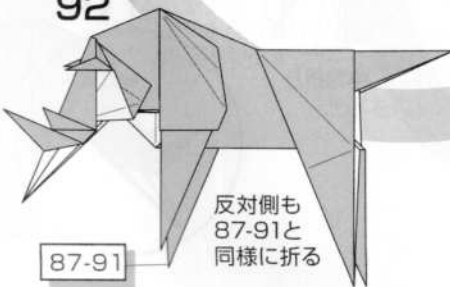

87-91

反対側も
87-91と
同様に折る

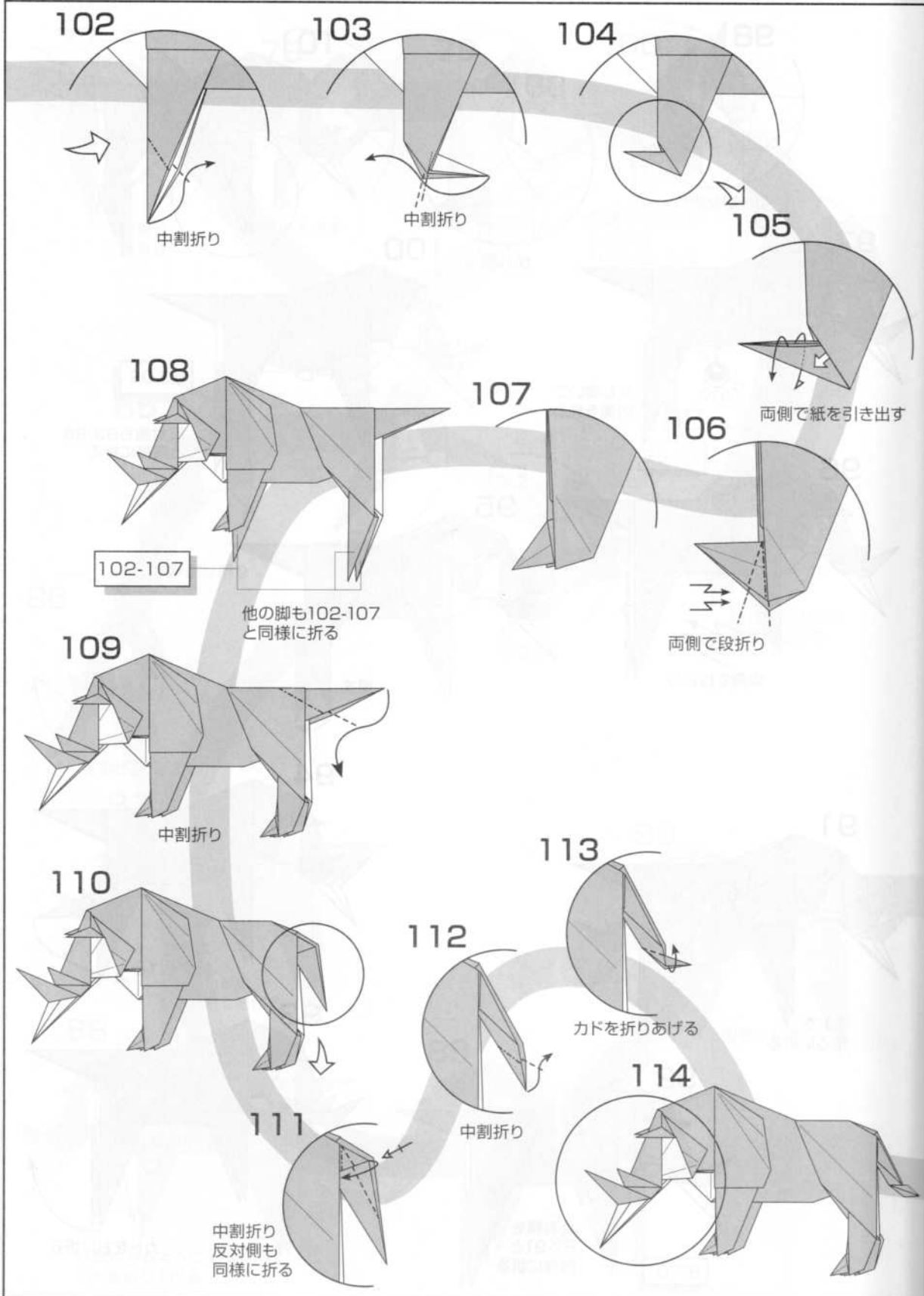

125

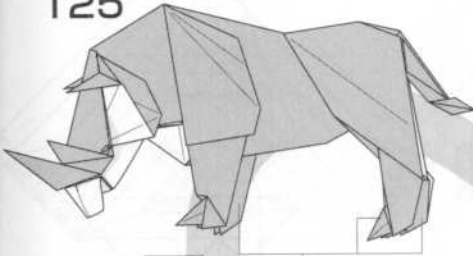

124

他の脚も124
と同様に折る

126

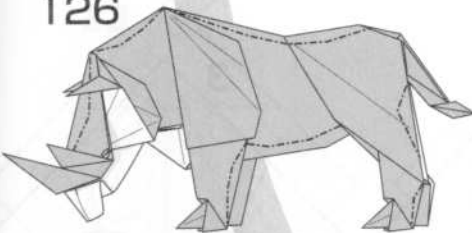

体を立体に仕上げる

127

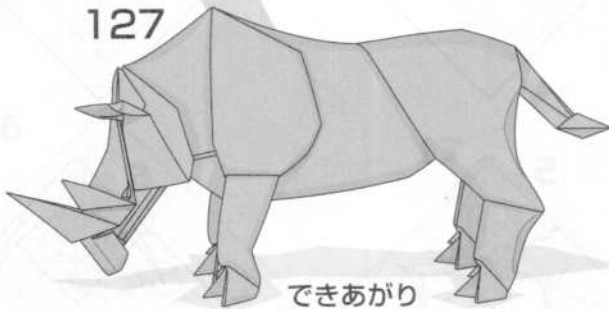

できあがり

123

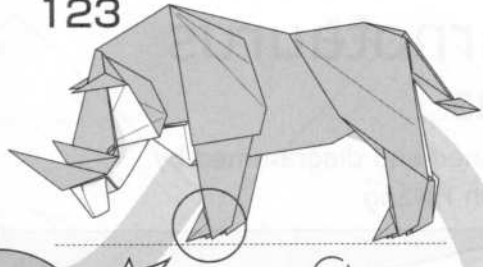

124

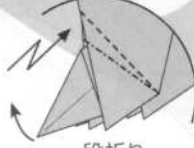

段折り

122

120-121

反対側も
120-121
と同様に折る

121



カドを
後ろに折る

120



カドをつぶして
目をつくる

119

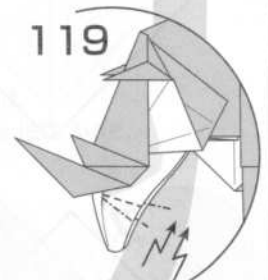

両側で段折り

117

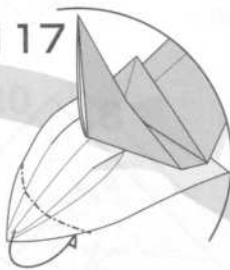

カドを内側に折る

116

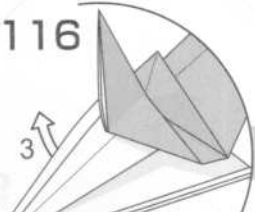

両側で
三枚ずつ
フチを引っ張り
先端をつぶす

118



内側を見る

115



内側を開く

Carnotaurus

2023

Designed and diagrammed by
Joseph Hwang

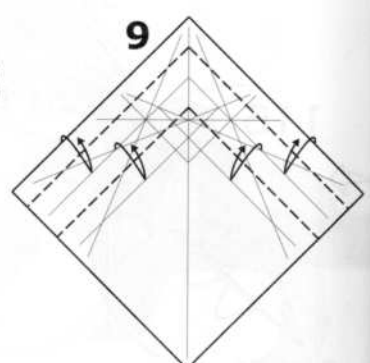
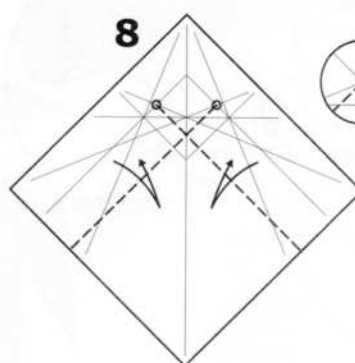
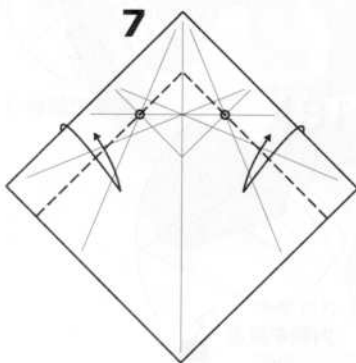
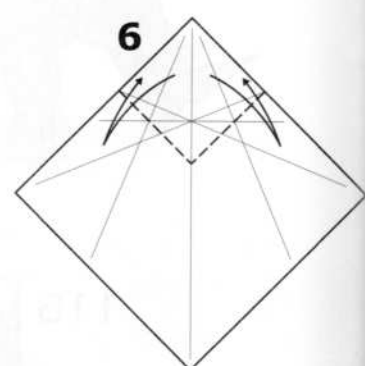
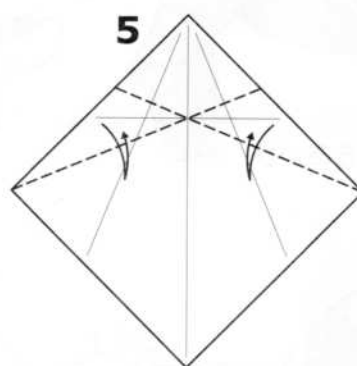
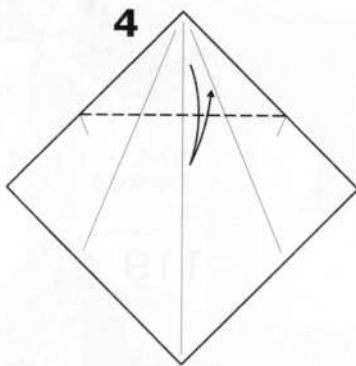
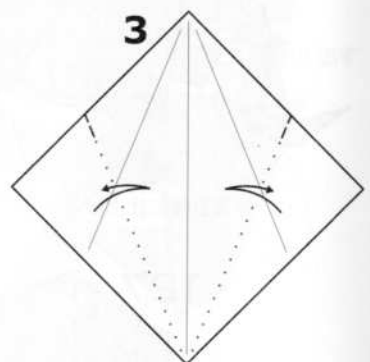
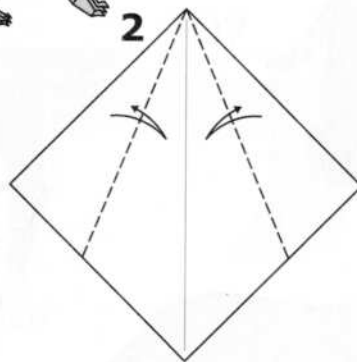
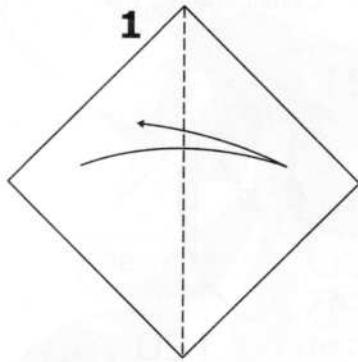
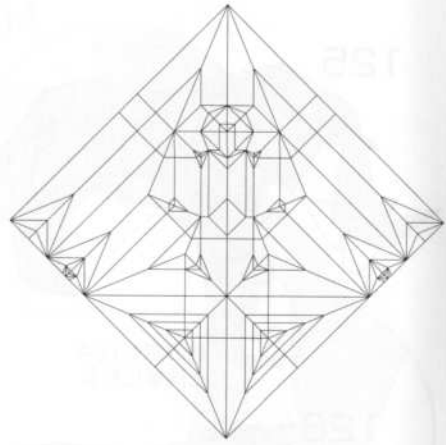
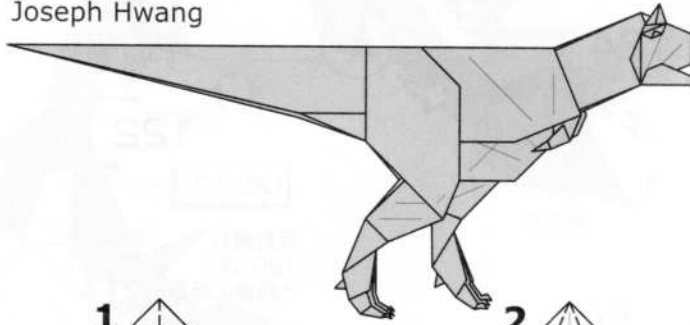

10

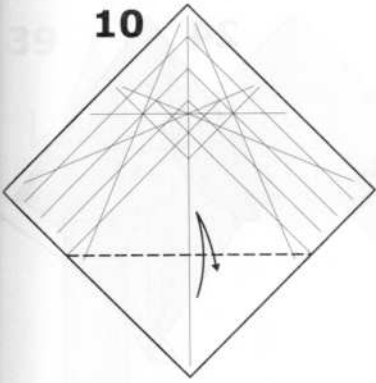

11

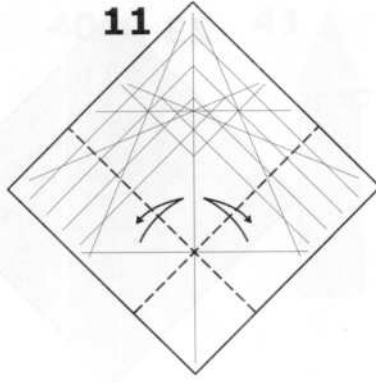

12

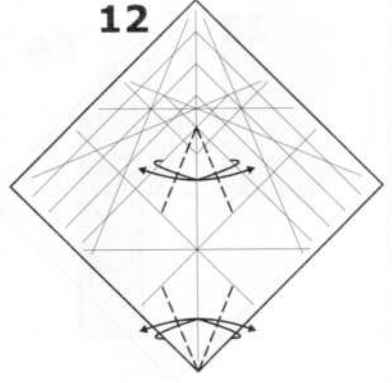

13

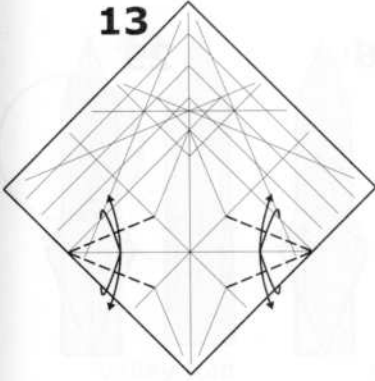

14

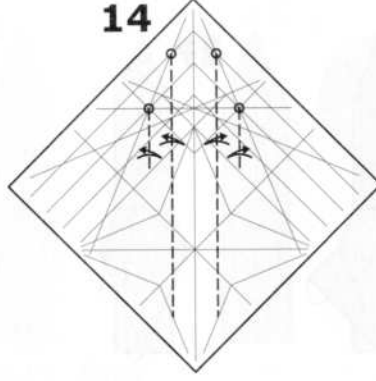

15

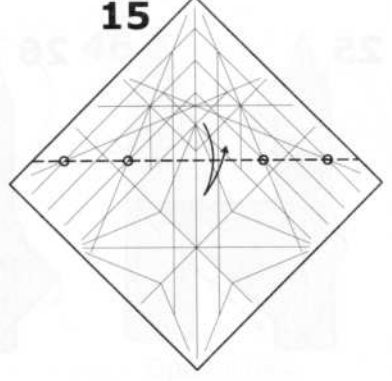

16

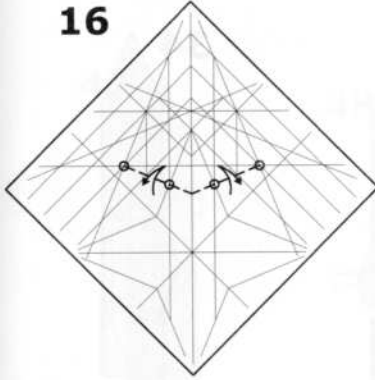

17

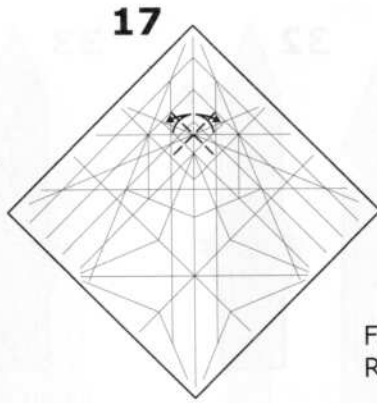

18

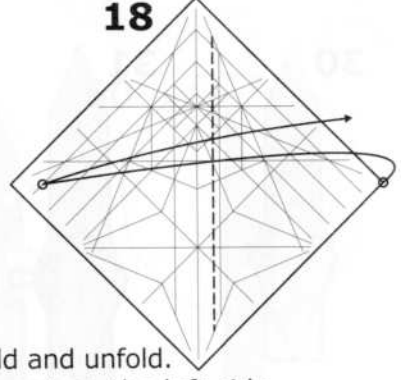

Fold and unfold.
Repeat on the left side.

19

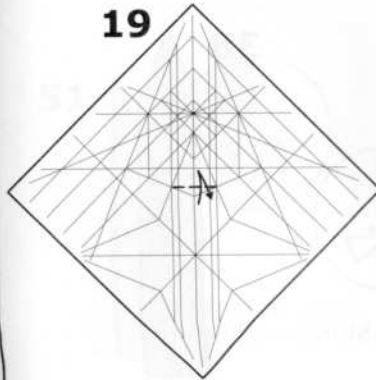

20

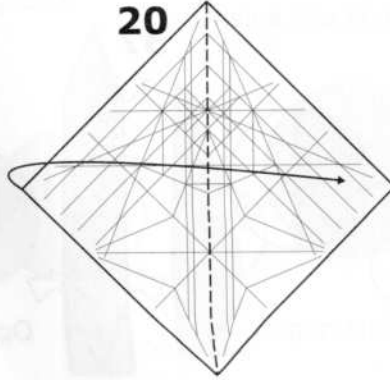

21

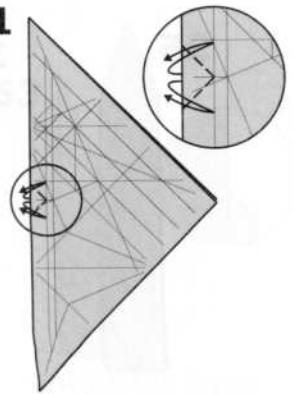

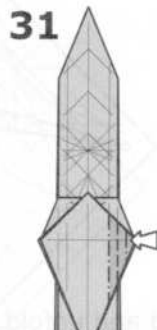
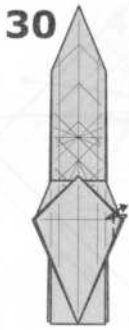
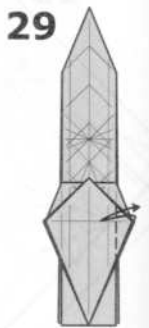
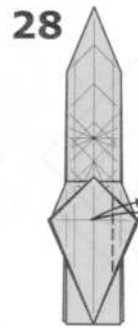
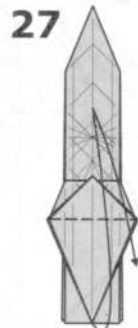
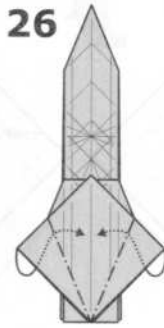
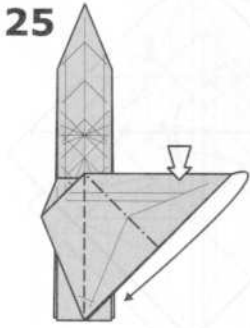
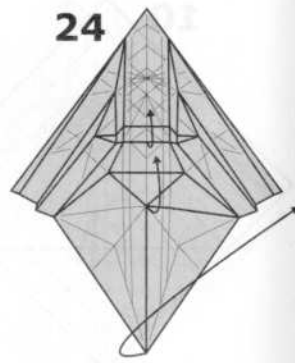
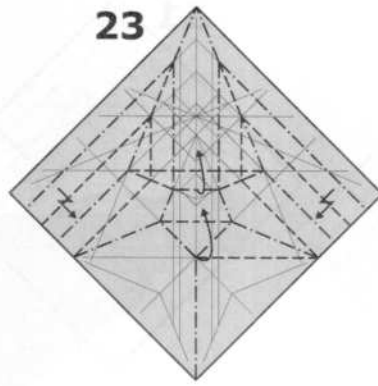
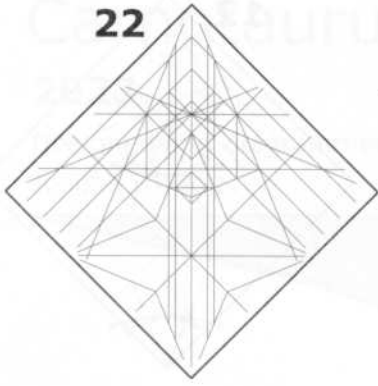

Open sink.

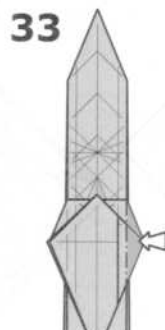
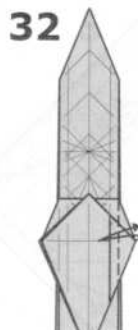

Open sink.

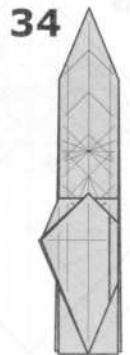

Repeat steps 28 to 33 on the left side.

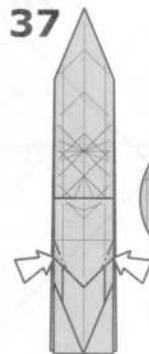
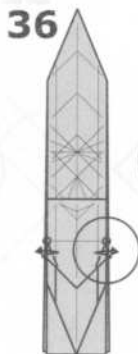
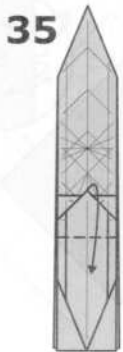

Open sinks.

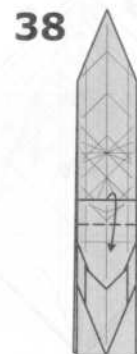

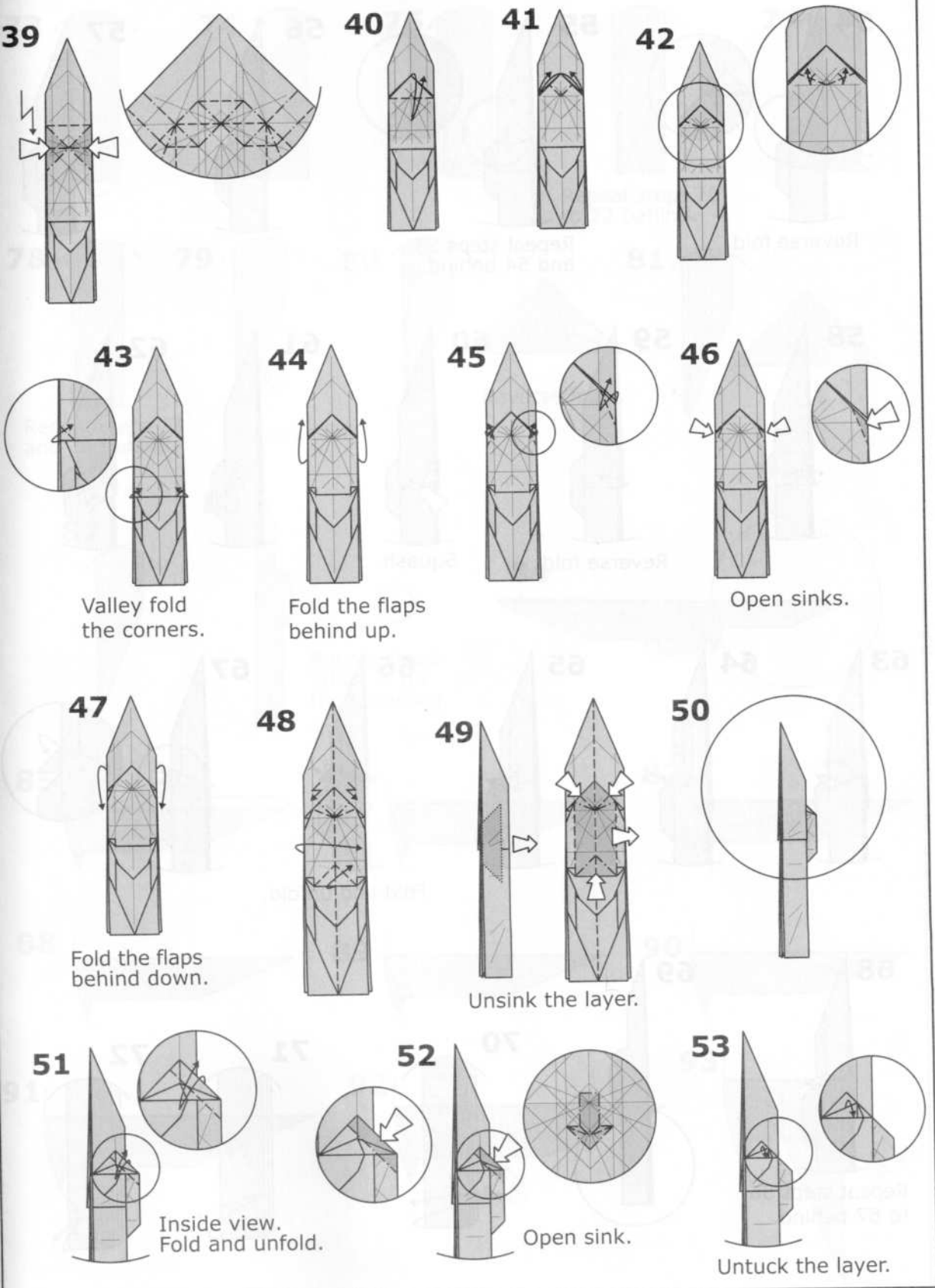

54

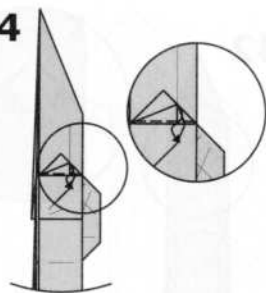

Reverse fold.

55

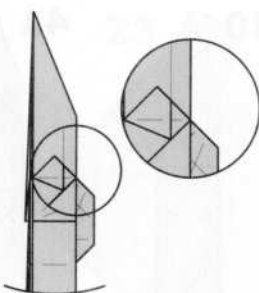

Repeat steps 53 and 54 behind.

56

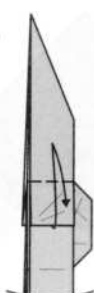

57

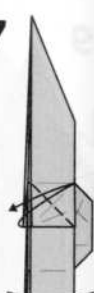

58

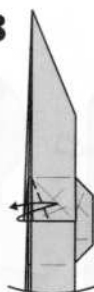

59

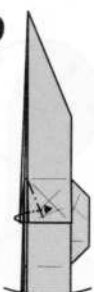

Reverse fold.

60



Squash.

61



62

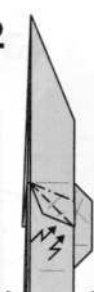

63



64



65

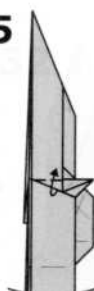

66

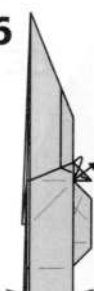

67



Fold and unfold.

68



Repeat steps 56 to 67 behind.

69

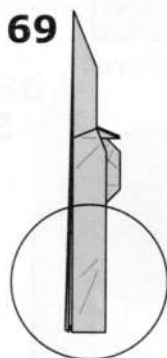

70

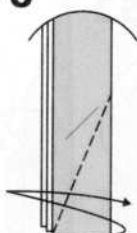

71

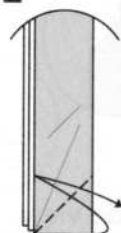

72

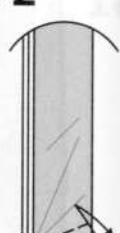

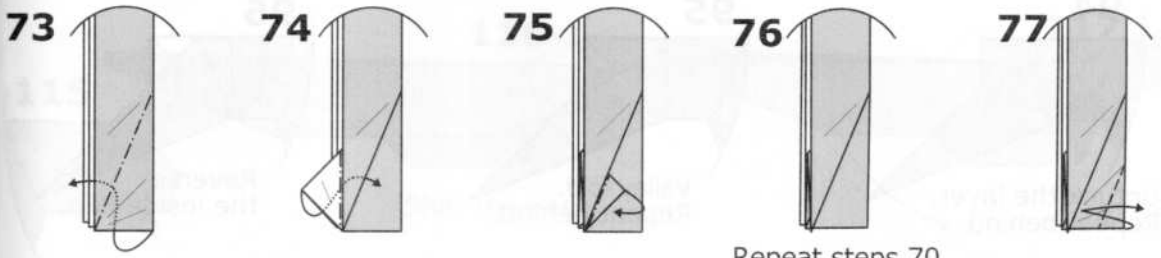

Repeat steps 70 to 72 behind.

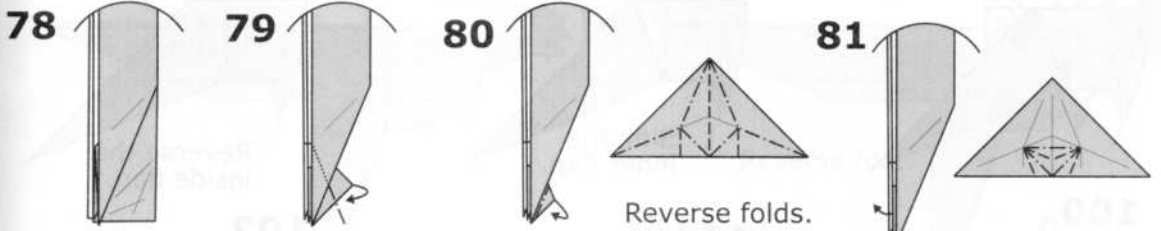

Repeat steps 73 and 74 behind.

Reverse fold.

Reverse folds.

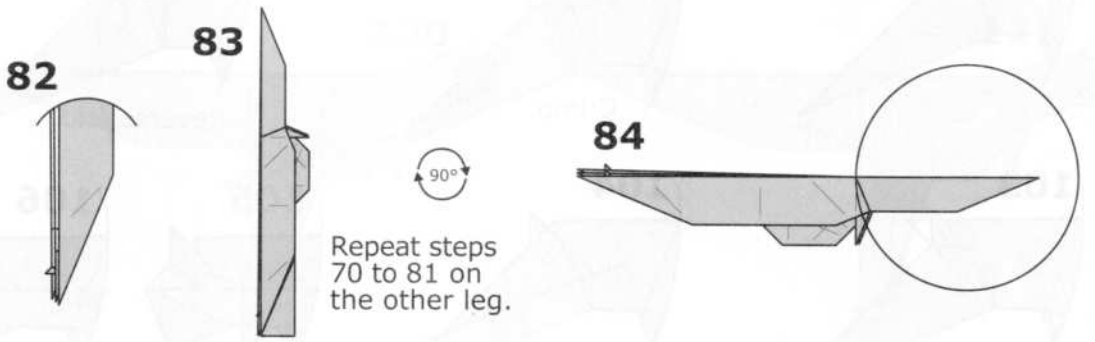

Repeat steps 70 to 81 on the other leg.

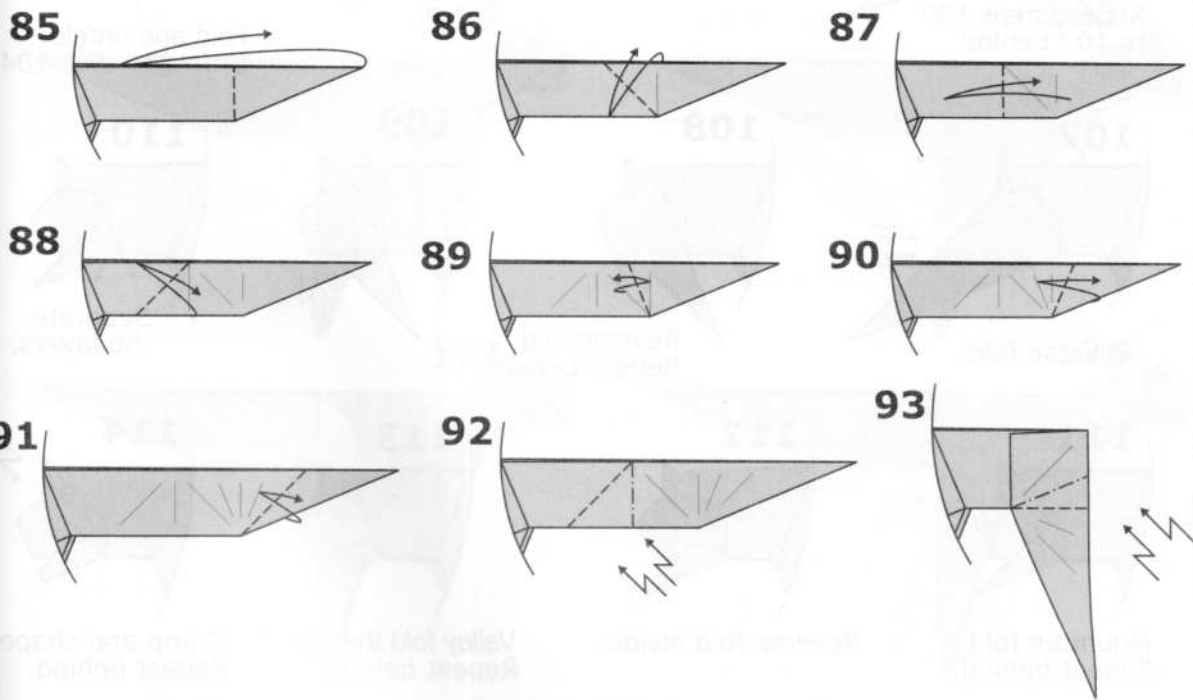

94

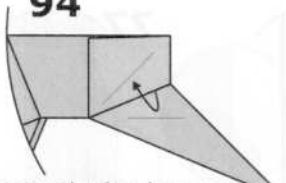

Untuck the layer.
Repeat behind.

95

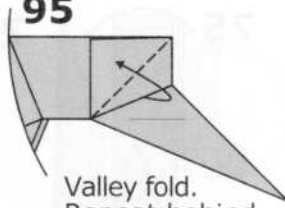

Valley fold.
Repeat behind.

96

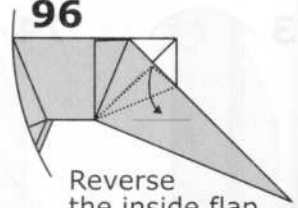

Reverse the inside flap.

97

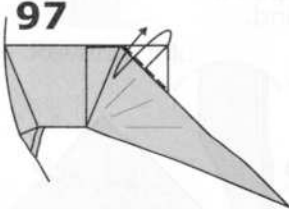

98

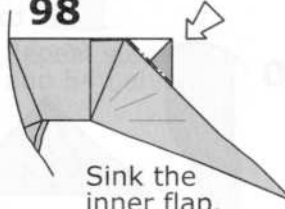

Sink the inner flap.

99

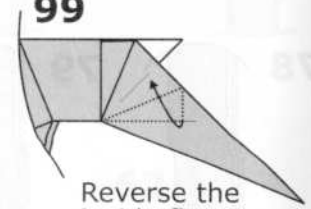

Reverse the inside flap.

100

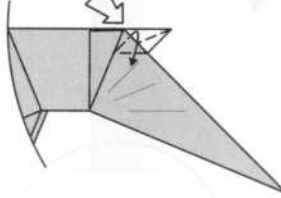

101

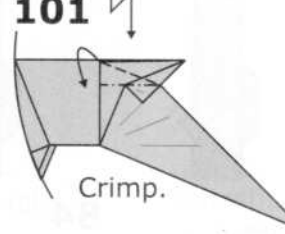

Crimp.

102

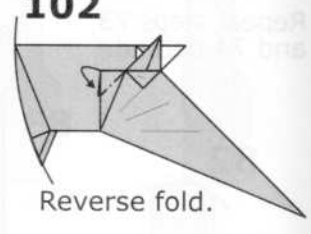

Reverse fold.

103

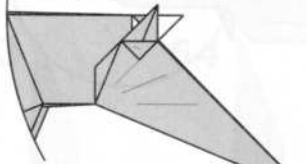

Repeat steps 100 to 102 behind

104

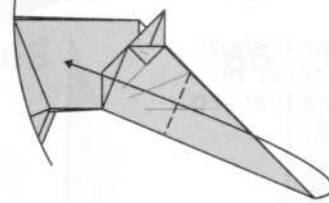

105

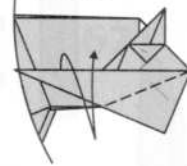

106

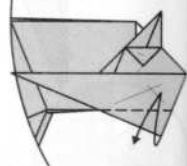

Fold and unfold.
Unfold to step 104

107

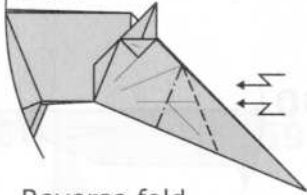

Reverse fold.

108

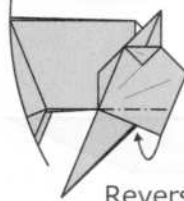

Reverse fold.
Repeat behind.

109

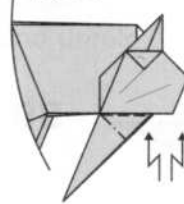

110

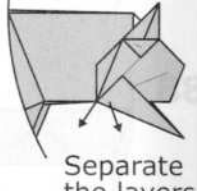

Separate the layers.

111

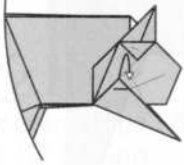

Mountain fold.
Repeat behind.

112

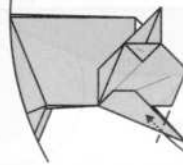

Reverse fold inside.

113

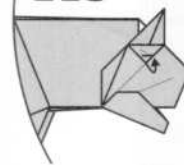

Valley fold the eye.
Repeat behind.

114

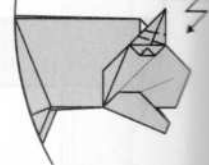

Crimp and shape.
Repeat behind.

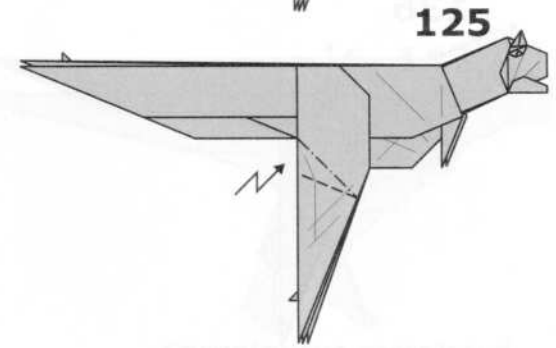
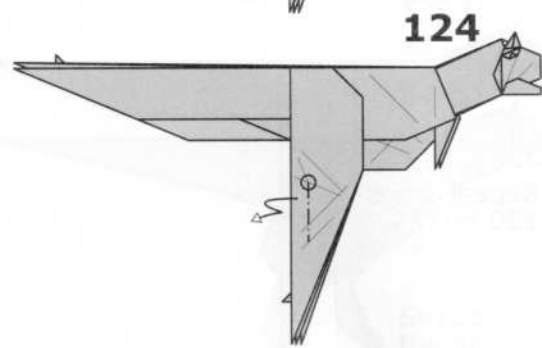
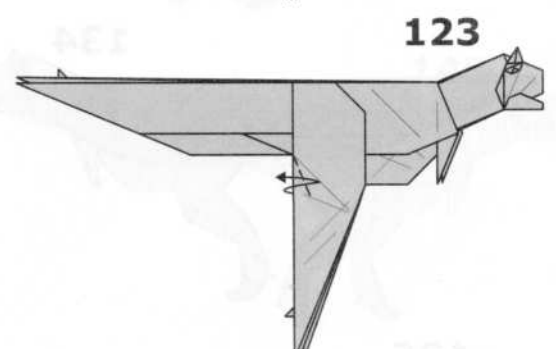
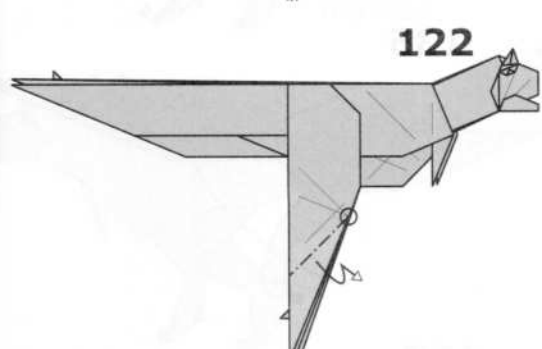
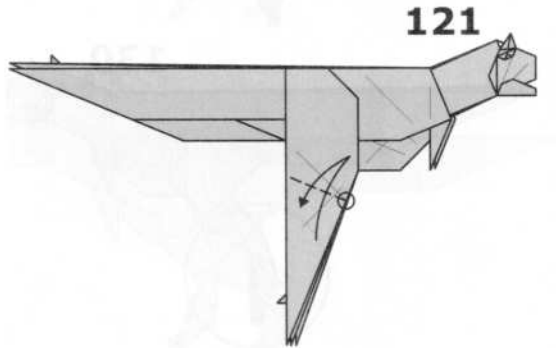
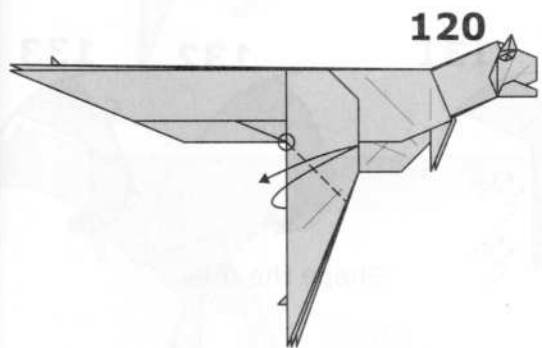
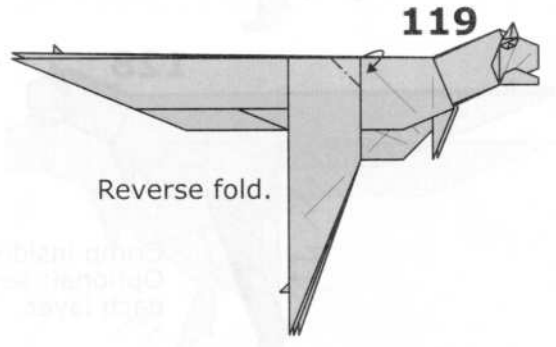
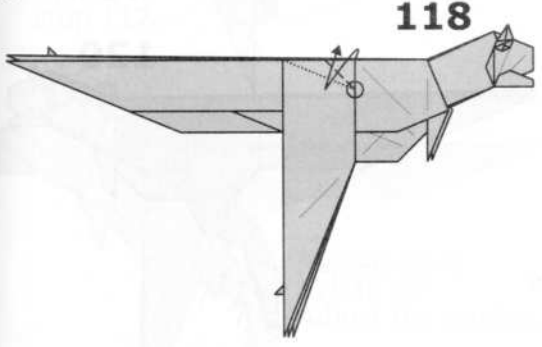
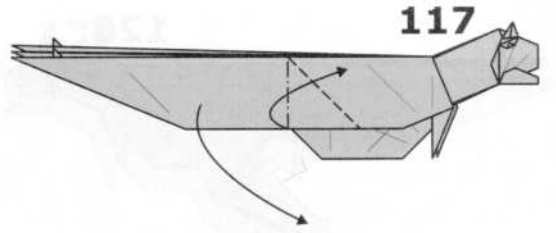
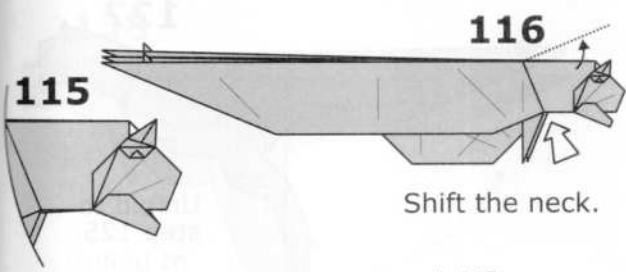

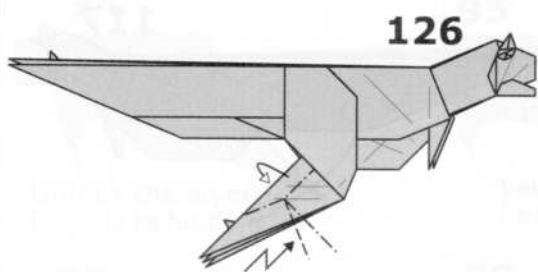

126

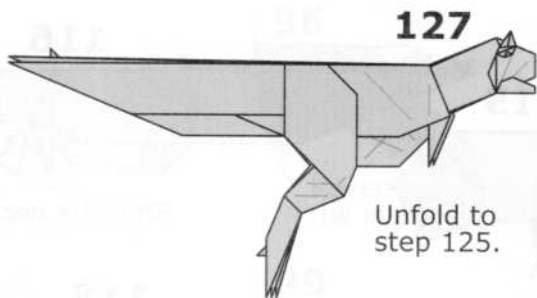

127

Unfold to step 125.

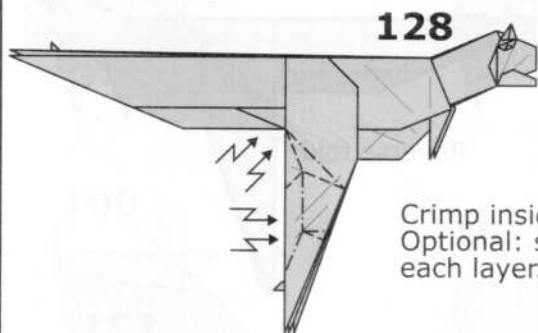

128

Crimp inside.
Optional: separate each layer.

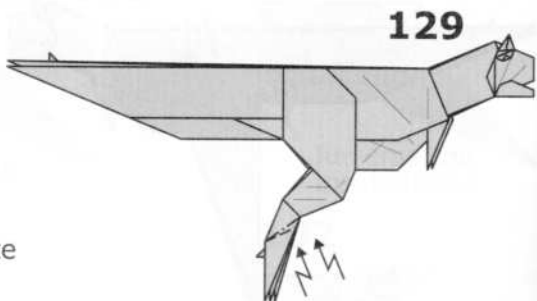

129

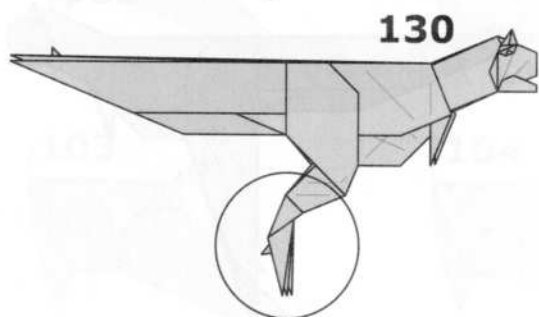

130



131



132



133

Shape the toes.

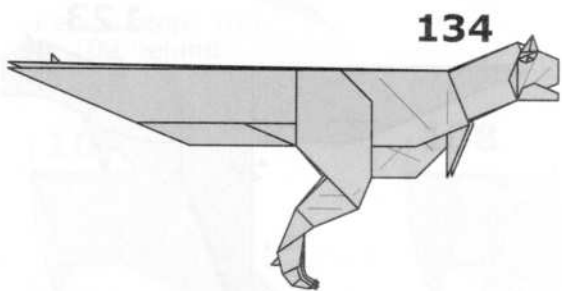

134

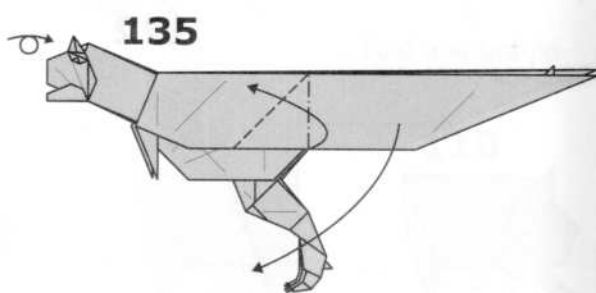

135

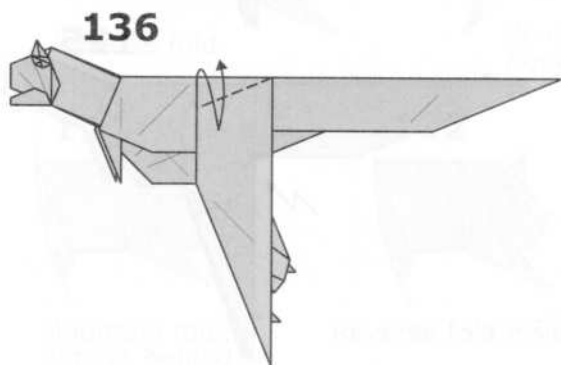

136

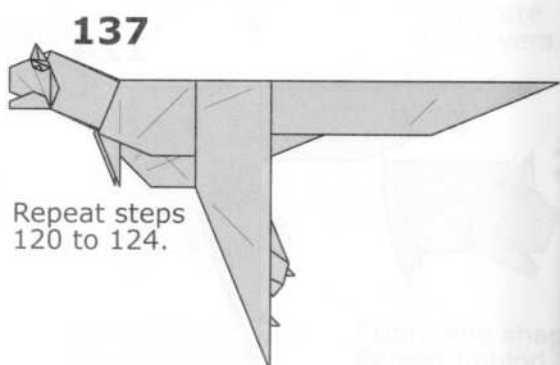

137

Repeat steps 120 to 124.

138

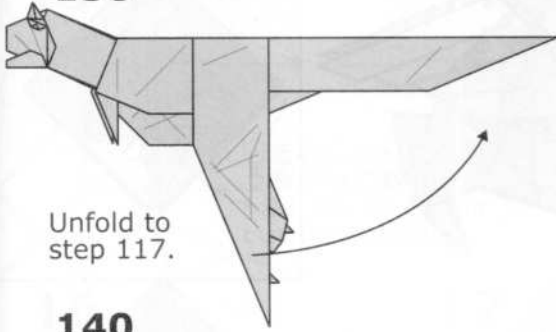

Unfold to step 117.

139

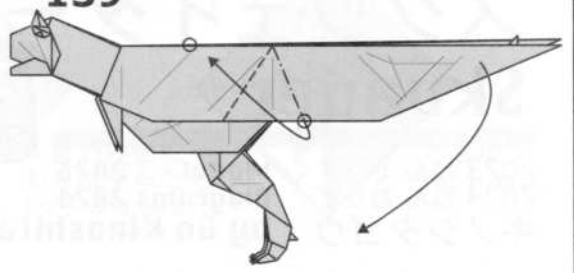

140

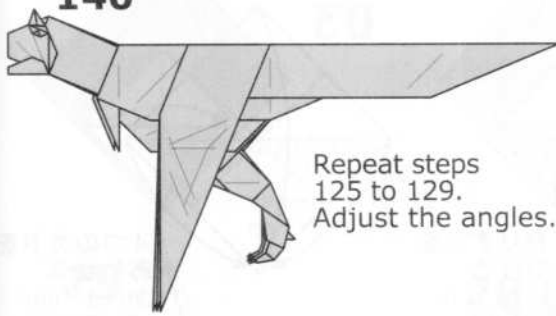

Repeat steps 125 to 129. Adjust the angles.

141

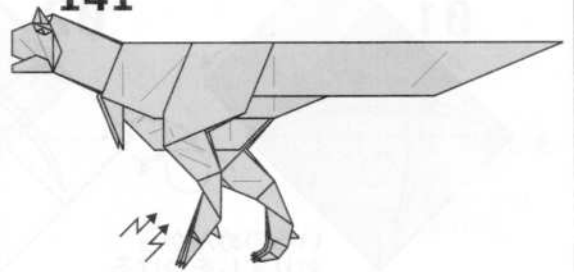

142

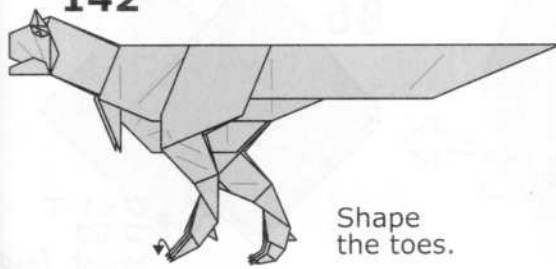

Shape the toes.

143

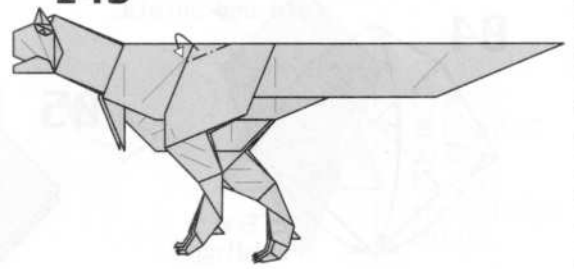

144

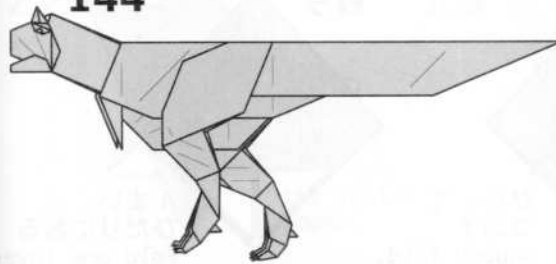

145

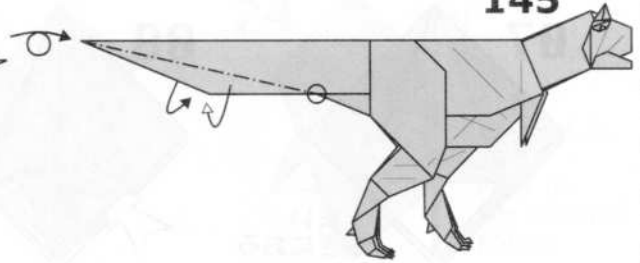

146

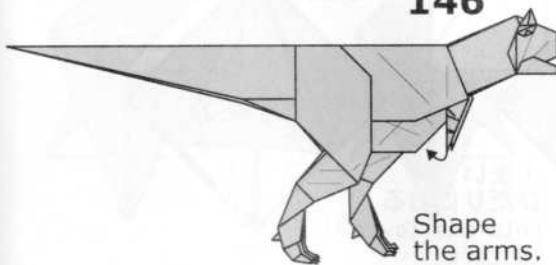

Shape the arms.

147

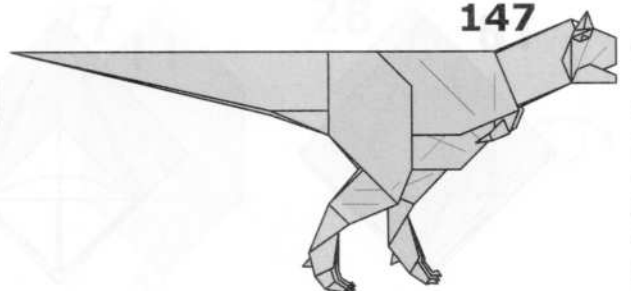

Carnotaurus completed.

スクヴェイダー Skvader

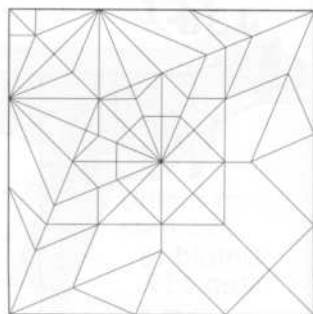
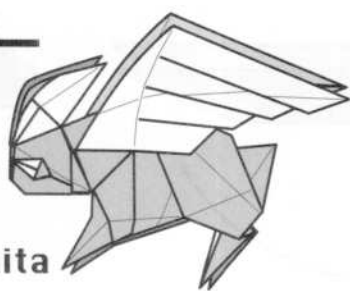

2023 ねん そうさく Model 2023
2024 ねん おりず Diagrams 2024
キノシタゴウ by Go Kinoshita

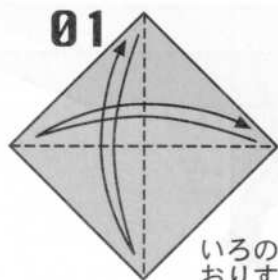

01

いろのめんから
おりすじをつける
Begin with the
colored side.
Fold and unfold.

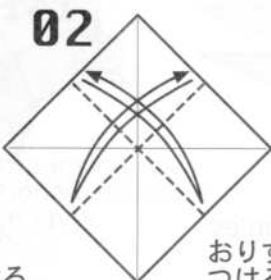

02

おりすじを
つける
Fold and
unfold.

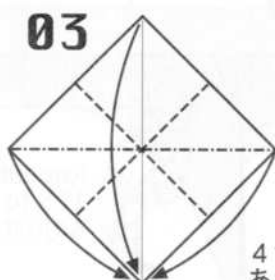

03

4つのカドを
あわせる
Unite four
corners.

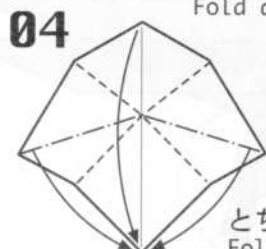

04

とちゅう
Folding...



05

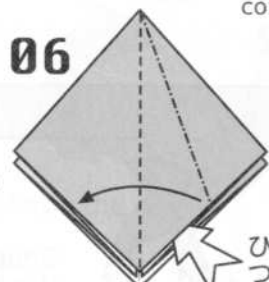

06

ひらいて
つぶす
Squash fold.

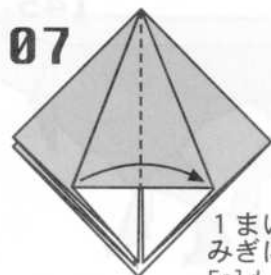

07

1まい
みぎにおる
Fold one layer
to right.

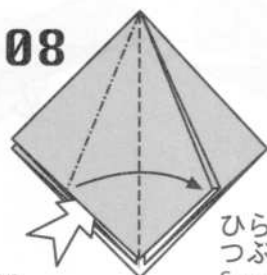

08

ひらいて
つぶす
Squash fold.



09

1まい
ひだりにおる
Fold one layer
to left.

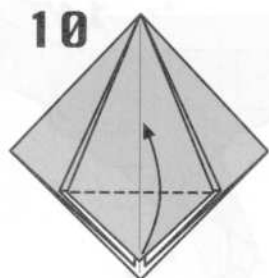

10

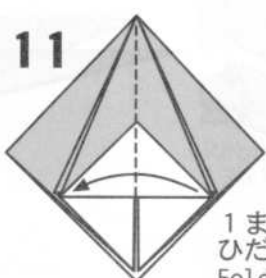

11

1まい
ひだりにおる
Fold one layer
to left.

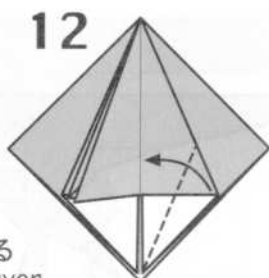

12

13

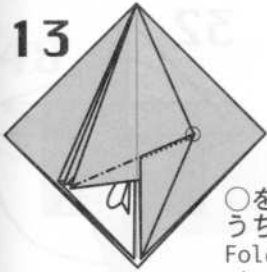

○をきじゅんに
うちがわにおる
Fold inside at the
circled points.

14

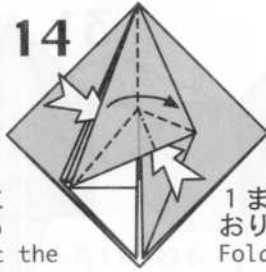

1まいみぎに
おりながらたたむ
Fold and pleat
one layer to right.

15

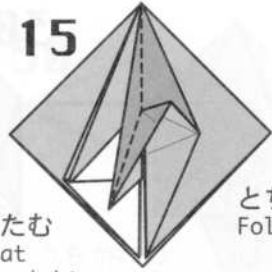

とちゅう
Folding...

16

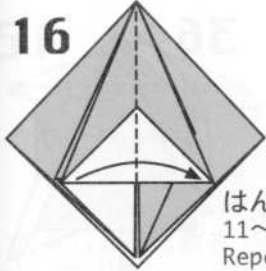

はんたいも
11~15 とおなじ
Repeat step 11-15
on the other side.

17

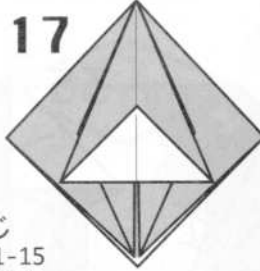

18

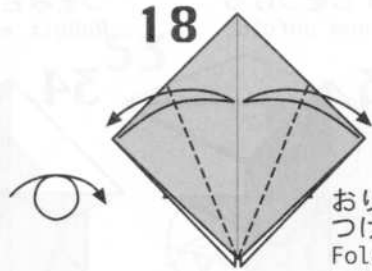

おりすじを
つける
Fold and
unfold.

19

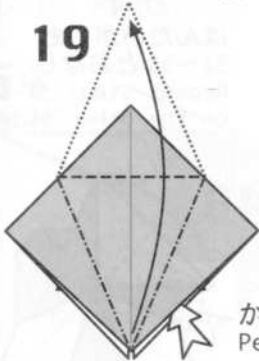

かべんおり
Petal fold.

20

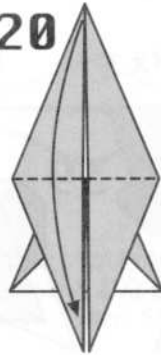

21

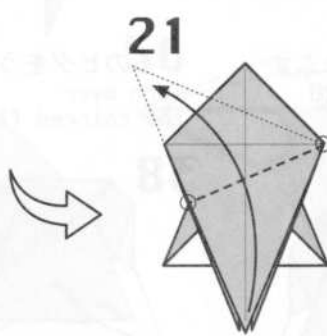

○を
きじゅんに
おる
Fold at
the circled
points.

22

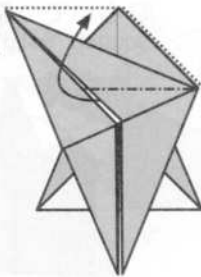

なかの
かみを
ひきだす
Pull out
the inside
paper.

23

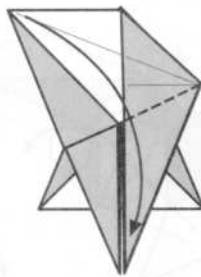

24

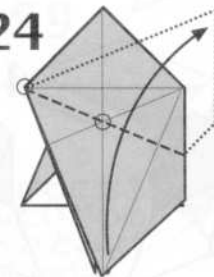

○を
きじゅんに
おる
Fold at
the circled
points.

25



なかの
かみを
ひきだす
Pull out
the inside
paper.

26

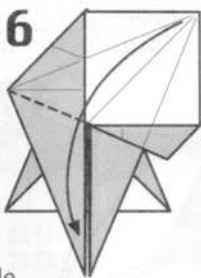

27

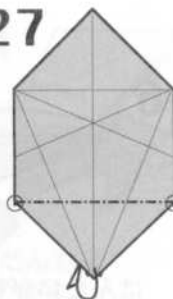

28

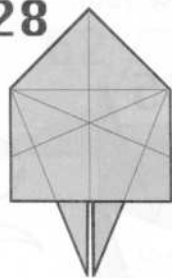

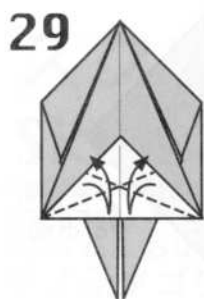

29 おりすじをつける
Fold and unfold.

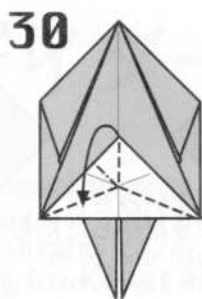

30 つまみおり
Rabbit ear.

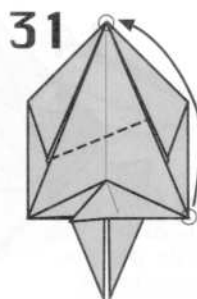

31

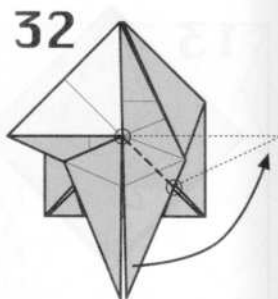

32

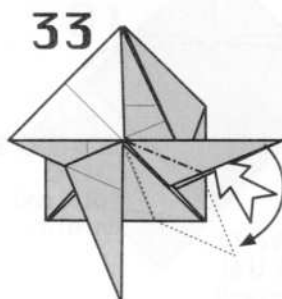

33 ひらいてつぶす
Squash fold.

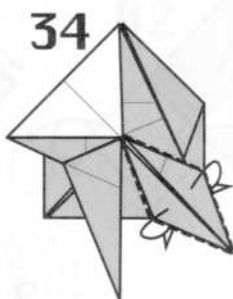

34 いろのヒダをうらがえす
Turn over
the colored flaps.

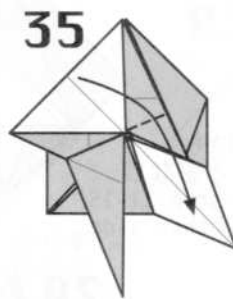

35

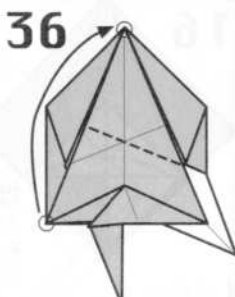

36

はんたいがわも
31~35 とおなじ
Repeat steps 31-35
on the other side.

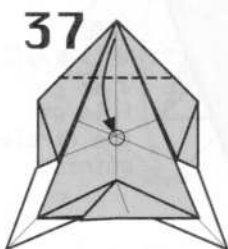

37



38

おりすじをつける
Crease.

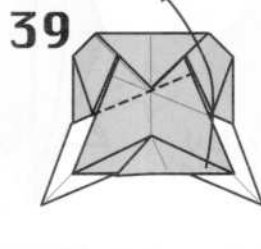

39

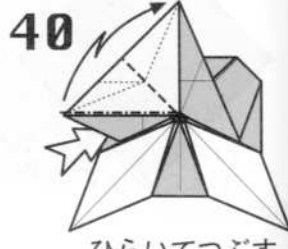

40

ひらいてつぶす
Squash fold.

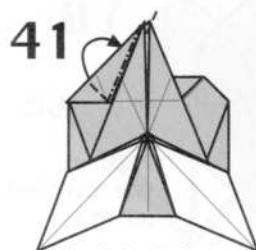

41

なかわりおり
Reverse fold.

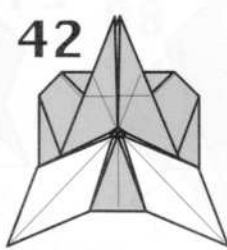

42

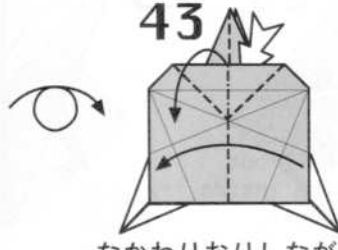

43

なかわりおりしながら
はんぶんにおる
Reverse fold while
folding in half.

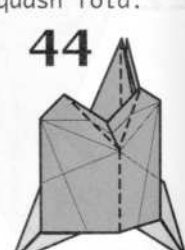

44

とちゅう
Folding...



45



46

はんたいがわもおなじ
Repeat behind.

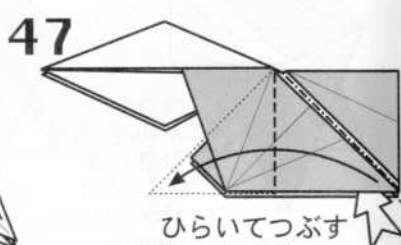

47

ひらいてつぶす
Squash fold.

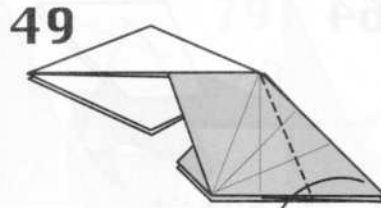
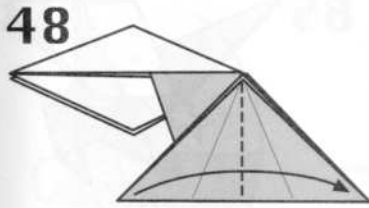

はんたいがわも
おなじ
Repeat behind.

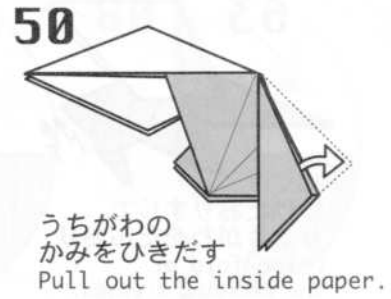

うちがわの
かみをひきだす
Pull out the inside paper.

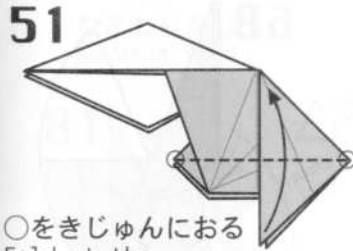

○をきじゅんにおろす
Fold at the
circled points.

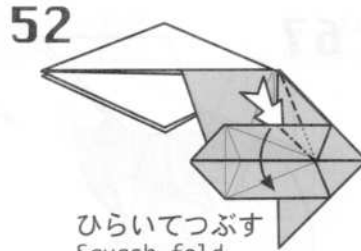

ひらいてつぶす
Squash fold.

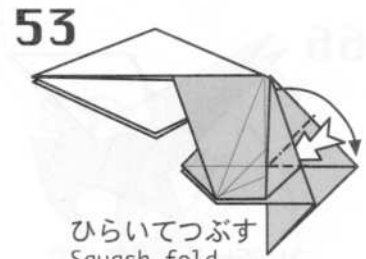

ひらいてつぶす
Squash fold.

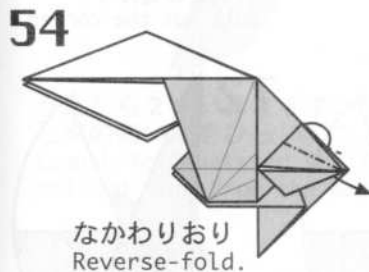

なかわりおり
Reverse-fold.

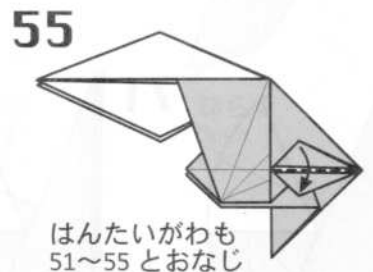

はんたいがわも
51~55 とおなじ
Repeat step 51-55 behind.

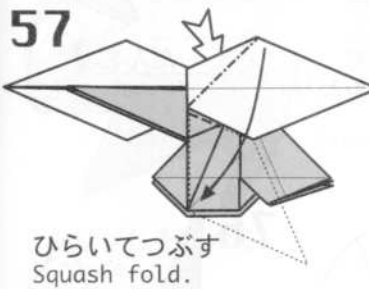
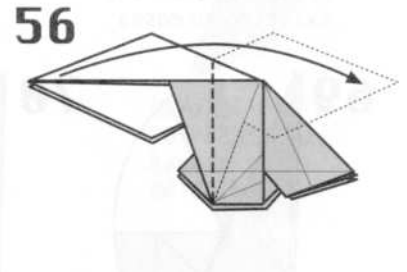

ひらいてつぶす
Squash fold.

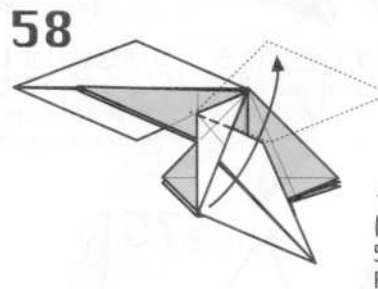

うちがわにおろす
はんたいがわも
56~59 とおなじ
Fold inside.
Repeat step 56-59 behind.

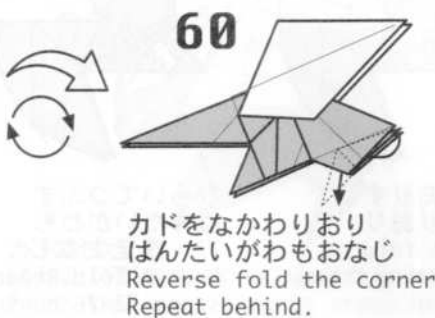

カドをなかわりおり
はんたいがわもおなじ
Reverse fold the corner
Repeat behind.

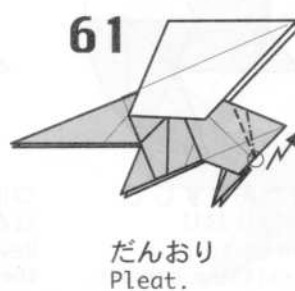

だんおり
Pleat.

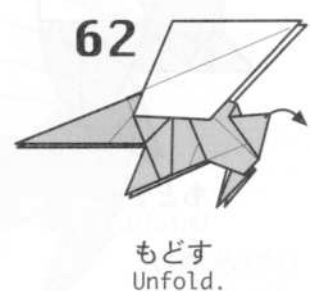

もどす
Unfold.

63

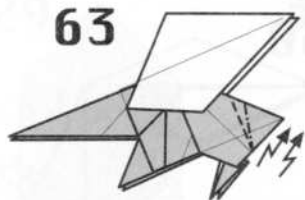

つけたおりすじで
りょうがわをだんおり
Crimp fold at
the existing creases.

64

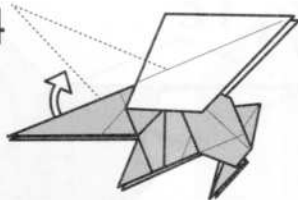

カドをひきだす
Pull out the corners.

65

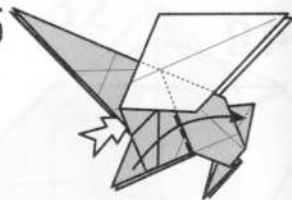

ひらく
Open.

66

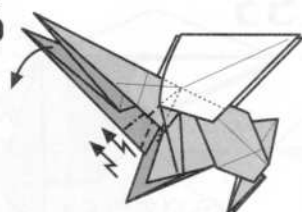

ついているおりすじで
りょうがわをだんおり
Crimp fold at the
existing creases.

67

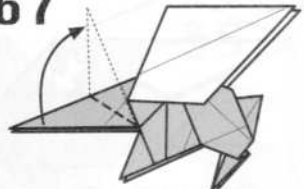

はんたいがわもおなじ
Repeat behind.

68

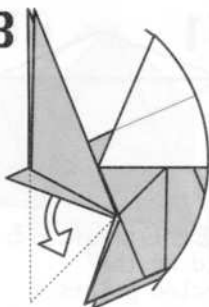

カドをひきだす
Pull out the corner.

69

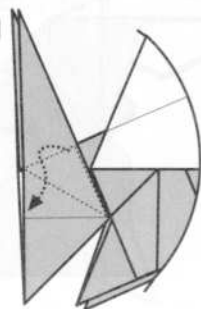

うちがわのカドを
なかわりおり
Reverse fold
the inside corner.

70

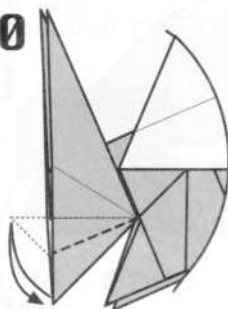

おりすじをつける
Fold and unfold.

71

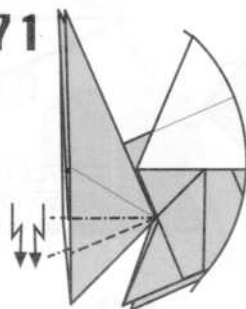

つけたおりすじで
りょうがわをだんおり
Crimp fold at
the existing creases.

72

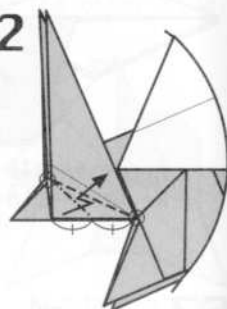

だんおり
Pleat.

73

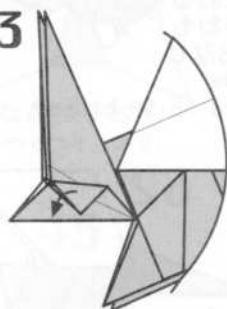

もどす
Unfold.

74

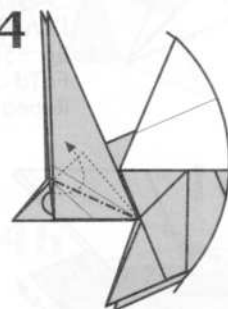

つけたおりすじで
なかわりおり
Reverse fold at
the existing creases.

75

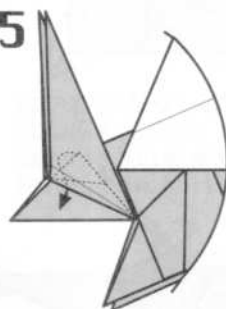

つけたおりすじで
なかわりおり
Reverse fold at
the existing creases.

76

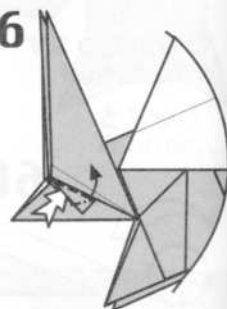

ひらいてつぶす
はんたいがわも
72~76 とおなじ
Squash fold.Repeat
steps 72-76 behind.

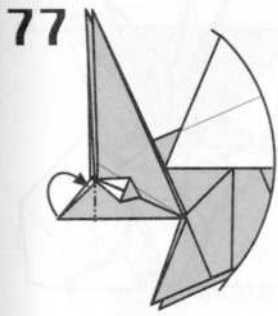

77 なかわりおり
Reverse fold.

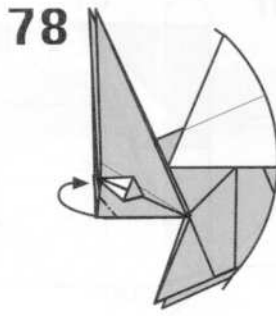

78 なかわりおり
Reverse fold.

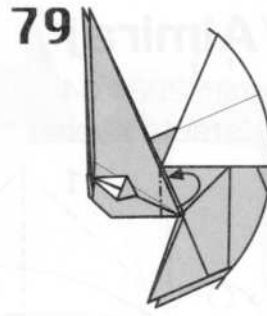

79 なかわりおり
Reverse fold.

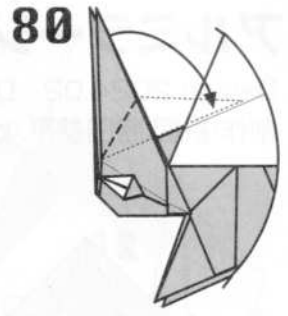

80

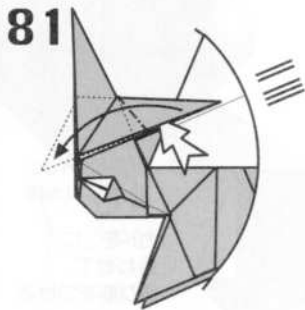

81

うえから2まいめと3まいめの
ヒダのあいだをひらいてつぶす
Squash fold between the 2nd
and 3rd flap from the top.

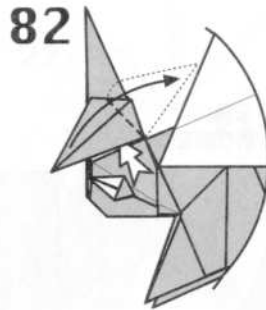

82

ひらく
Open.

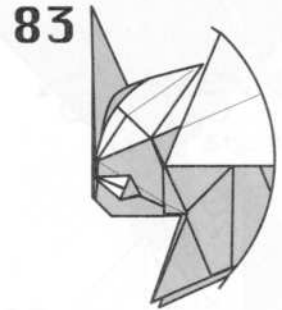

83

はんたいがわも
80~82 とおなじ
Repeat steps
80-82 behind.

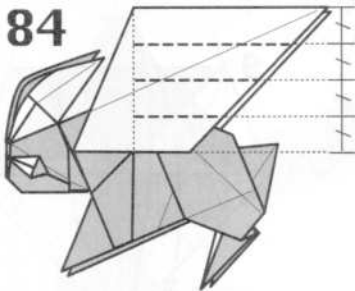

84

おりすじをつける
Crease.

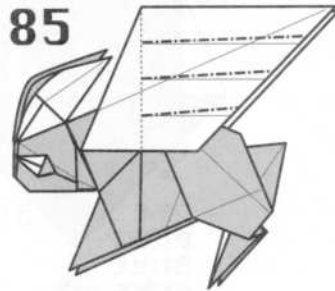

85

おりすじをつける
Crease.

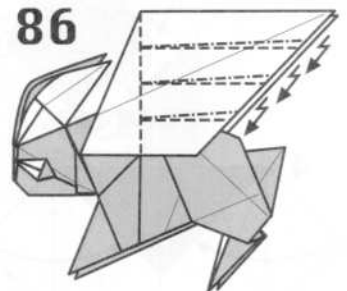

86

つけたおりすじでだんおり
Pleat at the existing crease.

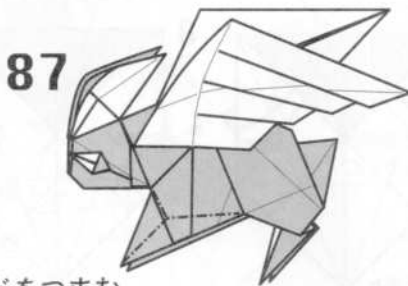

87

カドをつまむ
はんたいがわも 84~87 とおなじ
Pinch the corner. Repeat steps 84-87.

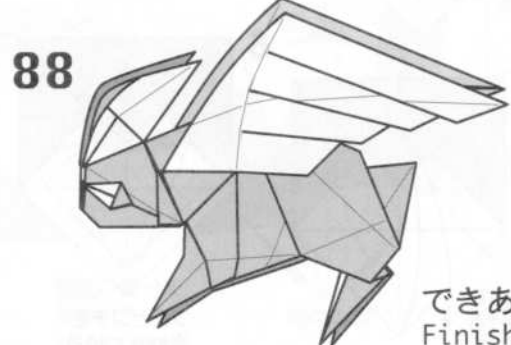

88

できあがり!
Finished!

アルミラージ/Almiraj

Design 2024.02 Diagram 2024.04

創作・折図:勝田恭平/by Katsuta Kyohei

