

The 29th ORIGAMI TANTEIDAN CONVENTION

第29回
折紙探偵団
コンベンション

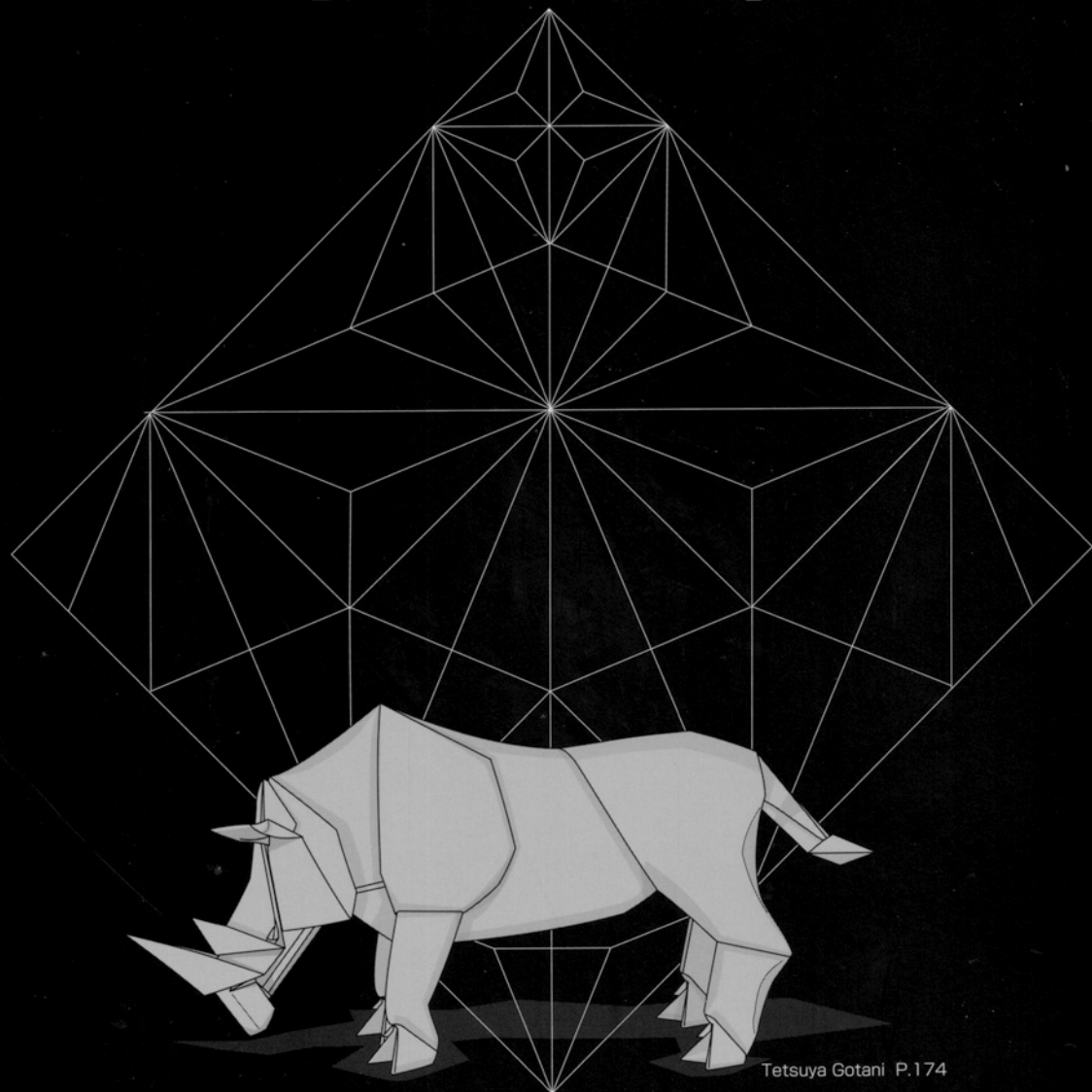

Tetsuya Gotani P.174

折り図集

Vol.29

発行・日本折紙学会

CONTENTS

折り図記号 Symbols for Folding	3		
基本形・沈め折り Preliminary Bases and Sink	4	カワウソ／神谷哲史	131
Crystalina／エカテリーナ・ルカシェヴァ	6	Otter／Satoshi Kamiya	
Crystalina／Ekaterina Lukasheva		コウモリ／佐藤悠樹	139
SSSSD／長山海澄	8	Bat／Yuki Sato	
SSSSD／Kaito Nagayama		ミカンのカピバラ／ブランドン・ワン	148
最果ての星／川村みゆき	11	Capybara with oranges／Brandon Wong	
Begining Star／Miyuki Kawamura		ヨーロッパアナグマ／ライアン・ウェルシュ	153
サメ／陳韋霖	14	European Badger／Ryan Welsh	
Shark／Wei Lin Chen		パンダ／小橋清貴	161
ラブカ／袋井一樹	18	Panda／Kiyotaka Kobashi	
Friiled shark／Kazuki Fukuroi		ライオン／加藤 眸	168
マンタ／桃原瑞季	23	Lion／Hitomi Kato	
Manta ray／Mizuki Tobaru		サイ／村木厚紀	171
シュモクザメ／稲吉秀尚	31	Rhinoceros／Atsunori Muraki	
Hammer-head shark／Hidehisa Inayoshi		サイ／合谷哲哉	174
コリドラス／ユアンカイ・ジャン	40	Rhinoceros／Tetsuya Gotani	
Corydoras／Yuankai Zhang		カルノタウルス／ジョセフ・ファン	184
シーラカンス／各務 均	49	Carnotaurus／Joseph Hwang	
Coelacanth／Hitoshi Kakami		スクヴェイダー／キノシタゴウ	194
イッカク／宮永智悠	60	Skvader／Go Kinoshita	
Narwhal／Tomohiro Miyanaga		アルミラージ／勝田恭平	200
海から顔を出したアザラシ／萩原 元	67	Almiraj／Kyohei Katsuta	
Seal peeping out of the sea／Gen Hagiwara		ユニコーン／庄司陽翔	209
バツカルコーン(クリオネ)／間瀬英一郎	77	Unicorn／Hikaru Shoji	
Buccal Cone(Clione)／Eiichiro Mase		龍／櫻本昌芳	218
カエル／生井敏一	84	Dragon／Masayoshi Enomoto	
Frog／Toshikazu Namai		鳳凰／大内康治	228
ねずみ2／小松英夫	91	Chinese Phoenix／Koji Ouchi	
Mouse2／Hideo Komatsu		まかいのおにぎり5号／北條高史	238
猫／マックス・ダンジェ	96	Riceball from Hell #5／Takashi Hojyo	
Cat／Max d'Anger		いなり寿司／田中幹人	241
うさぎ／山北克彦	105	INARI SUSHI／Mikito Tanaka	
Rabbit／Katsuhiko Yamakita		アジの開き／荒牧遼太郎	244
うさぎの葉／霞 誠志	111	Sun-dried horse mackerel／Ryotaro Aramaki	
Rabbit Bookmark／Seishi Kasumi		シンプルローストチキン／イエリ・アストロナ	250
モモンガ／小林弘明	114	Simple Roast Chicken／Yery Astrona	
Flying Squirrel／Hiroaki Kobayashi		石川県／松田景吾	258
キツネ／尾川 知	120	Ishikawa Prefecture／Keigo Matsuda	
Fox／Tomo Ogawa		パペット(3種)／宮島 登	262
カワウソ／進藤大雅	127	Puppets／Noboru Miyajima	
River otter／Taiga Shinto		フォークリフト／キム・ジンウ	266
		Fork lift／Kim Jin Woo	

折り図記号 Symbols for Folding

折り線の種類 Types of crease lines

谷折り線 Valley fold



谷折り
Valley fold

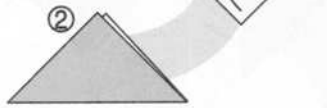

山折り線 Mountain fold



山折り Mountain fold

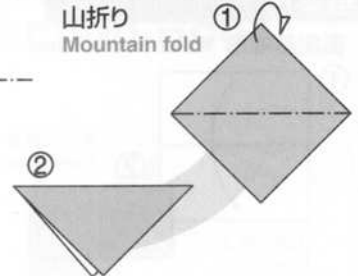

折り方の技法 Basic Folding Skills

中わり折り Inside-reverse fold

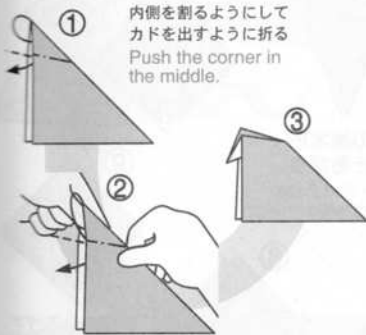

かぶせ折り Outside-reverse fold

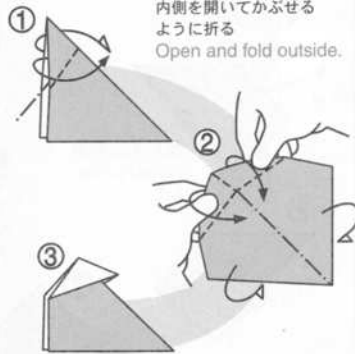

内側をひろげてつぶすように折る Squash fold

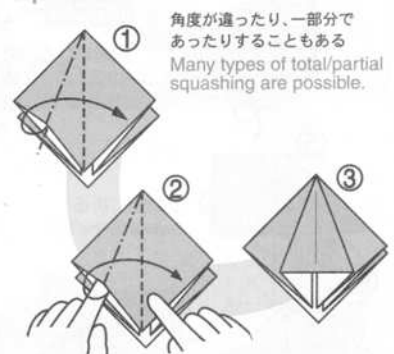

いろいろな記号 Symbols

折り筋をつける Making a crease line

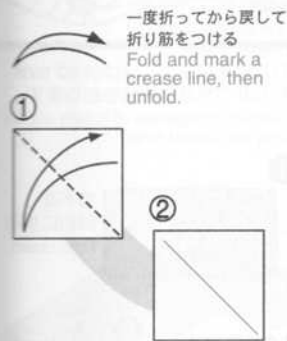

裏返す Turn paper over

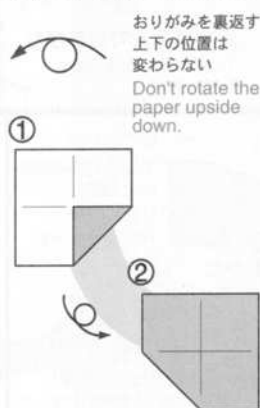

段折り Pleat fold

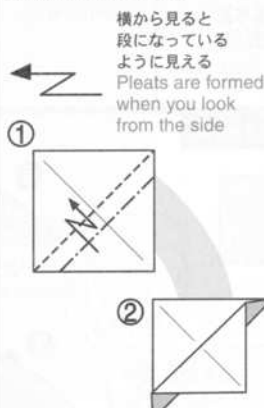

下の部分を出すように折る Release bottom flap when making a fold

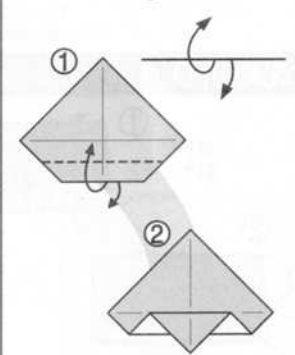

次の図が大きくなる
A magnified view

ひろげる Open up

次の図の見る位置が変わる
Paper position changes (rotation)

等分記号 Division

仮想線・透視線
A hidden line

○と○を合わせて折る
Match circled points

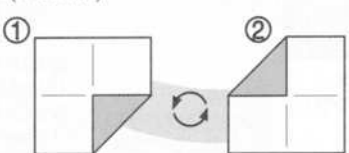

長さの等分 Dividing the length

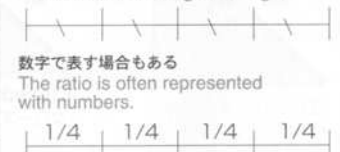

押す・つぶす
Push paper in

巻くように折る
Roll the flap by repeated folds



角度の等分
Dividing the angle

1つの図で2種類の等分を表す場合

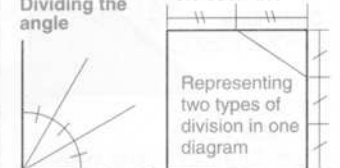

引き出す
Pull out

注意するところ
Marked points



基本形 / 沈め折り Preliminary Bases and Sink

基本形 Preliminary bases

風船基本形 Water Bomb Base

① 半分に折る
Fold in half.

② 半分に折る
Fold in half again.

③ 内側をひろげて つぶすように折る
Open and squash.

④ 反対側に折る
Swivel to the left.

⑤ 内側をひろげて つぶすように折る
Open and squash.

⑥ 反対側に折る
Swivel to the left.

⑦ 内側をひろげて つぶすように折る
Open and squash.

風船基本形 できあがり
The Water Bomb Base completed.

正方基本形と鶴の基本形 Preliminary Base / Bird Base

① 三角に折る
Fold corner to corner.

② 三角に折る
Fold in half.

③ 内側をひろげて つぶすように折る
Open and squash.

④ 反対側に折る
Swivel to the left.

⑤ 反対側に折る
Swivel to the left.

⑥ 内側をひろげて つぶすように折る
Open and squash.

⑦ 内側をひろげて つぶすように折る
Open and squash.

⑧ 縁を中心に合わせて 折り筋をつける
Fold the lower edges to the center diagonal.

⑨ 反対側も ⑥～⑨と同じ
Repeat ⑥～⑨ on the back.

⑩ 反対側も ⑥～⑨と同じ
Repeat ⑥～⑨ on the back.

⑪ 鶴の基本形 できあがり
The Bird Base completed.

正方基本形 できあがり
The Preliminary Base completed.

沈め折り Open sink / Closed sink

① カドを斜めに折る
Fold down.

② カドを内側に折る
Inside reverse fold.

③ 沈め折りをする部分にしっかりと折り筋をつける
Mark the crease line to use for sink.

④ つけた折り筋を使って沈めるように折る
Push the arrowed corner inside ...

⑤ 途中の図全体をひろげてから押し込むように折る
After opening the corner lightly, push in without overlapping layers.

⑥ 紙のひだが開いた (open) かたちになっている
The layers can be reopened.

Open sink (オープン・シンク)

① カドを斜めに折る
Fold down.

② カドを内側に折る
Inside reverse fold.

③ 沈め折りをする部分にしっかりと折り筋をつける
Mark the crease line to use for sink.

④ つけた折り筋を使って沈めるように折る
Push the arrowed corner inside ...

⑤ 途中の図全体をひろげてから押し込むように折る
After opening the corner lightly, push in without overlapping layers.

⑥ 紙のひだが閉じた (closed) かたちになっている
The layers are locked.

できあがり
Closed sink completed.

① カドを斜めに折る
Fold down.

② 沈め折りをする部分にしっかりと折り筋をつける
Mark the crease line to use for sink.

③ つけた折り筋を使って沈めるように折る
Push in the corner.

④ できあがり
The closed sink completed.

第29回折紙探偵団コンベンション折り図集

29th Origami Tanteidan Convention Book



Hideo Komatsu P.91

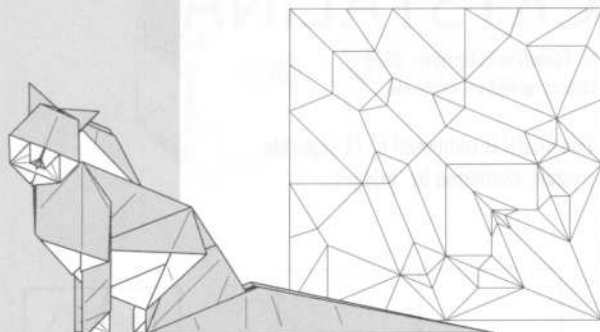

Max d'Anger P.96

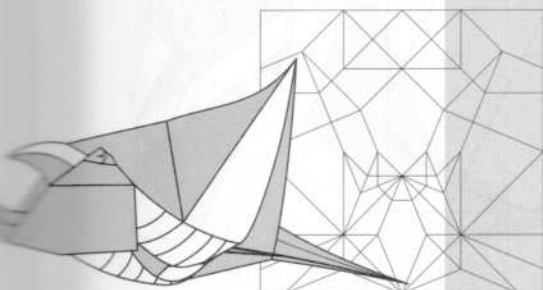

Mizuki Tobaru P.23

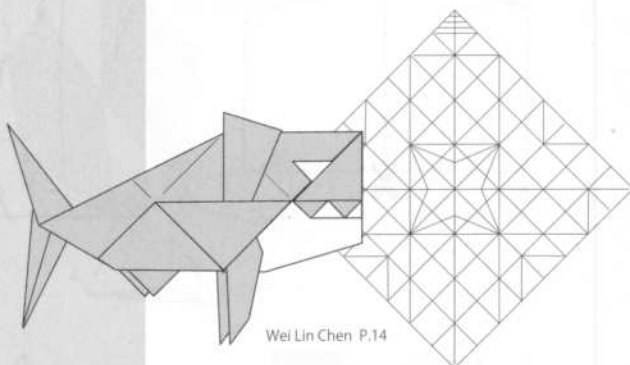

Wei Lin Chen P.14

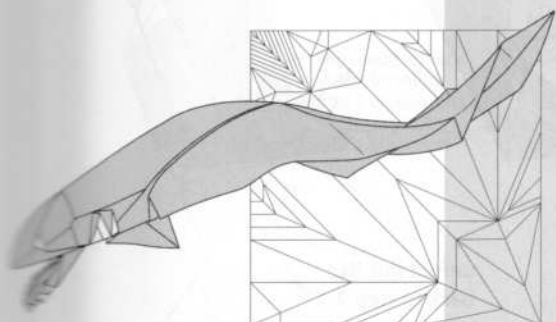

Kazuki Fukuroi P.18



Eiichiro Mase P.77

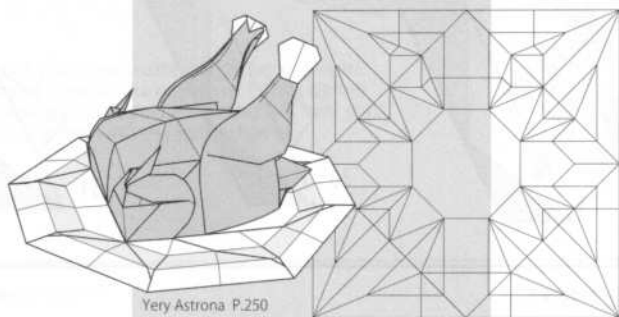

Yery Astrona P.250



15 x 7.5 cm x 30 units

CRYSTALINA

© Ekaterina Lukasheva, 2023

contact: art@kusudama.me

This model is composed of 12 separate crystals, connected by 'bridges'.

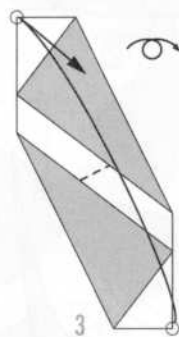
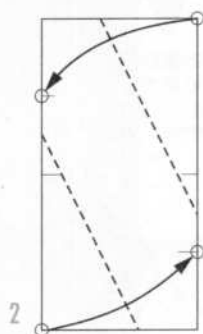
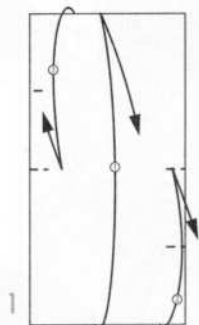
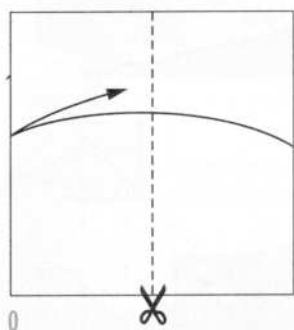
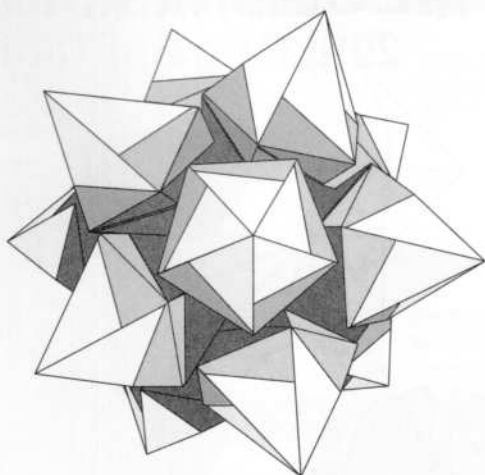

fold only
one layer

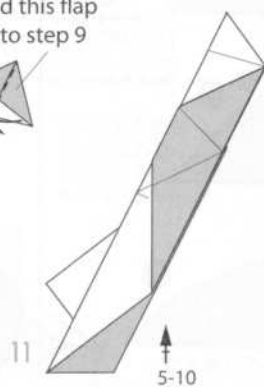
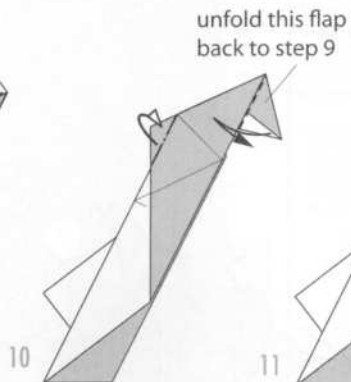
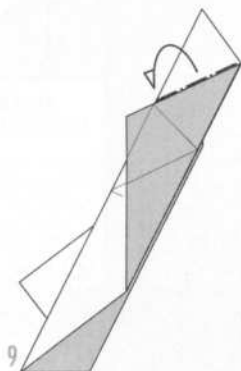
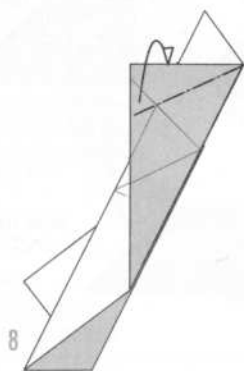
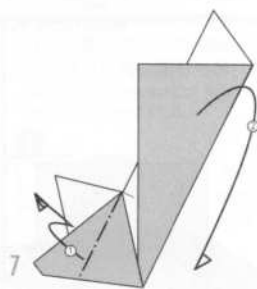
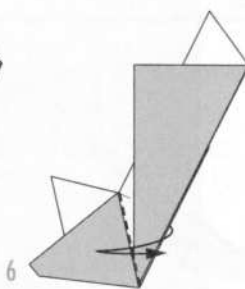
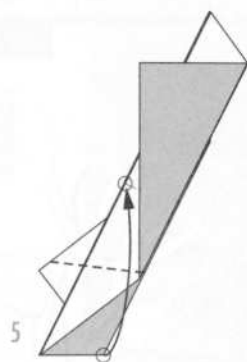
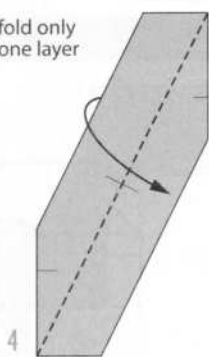

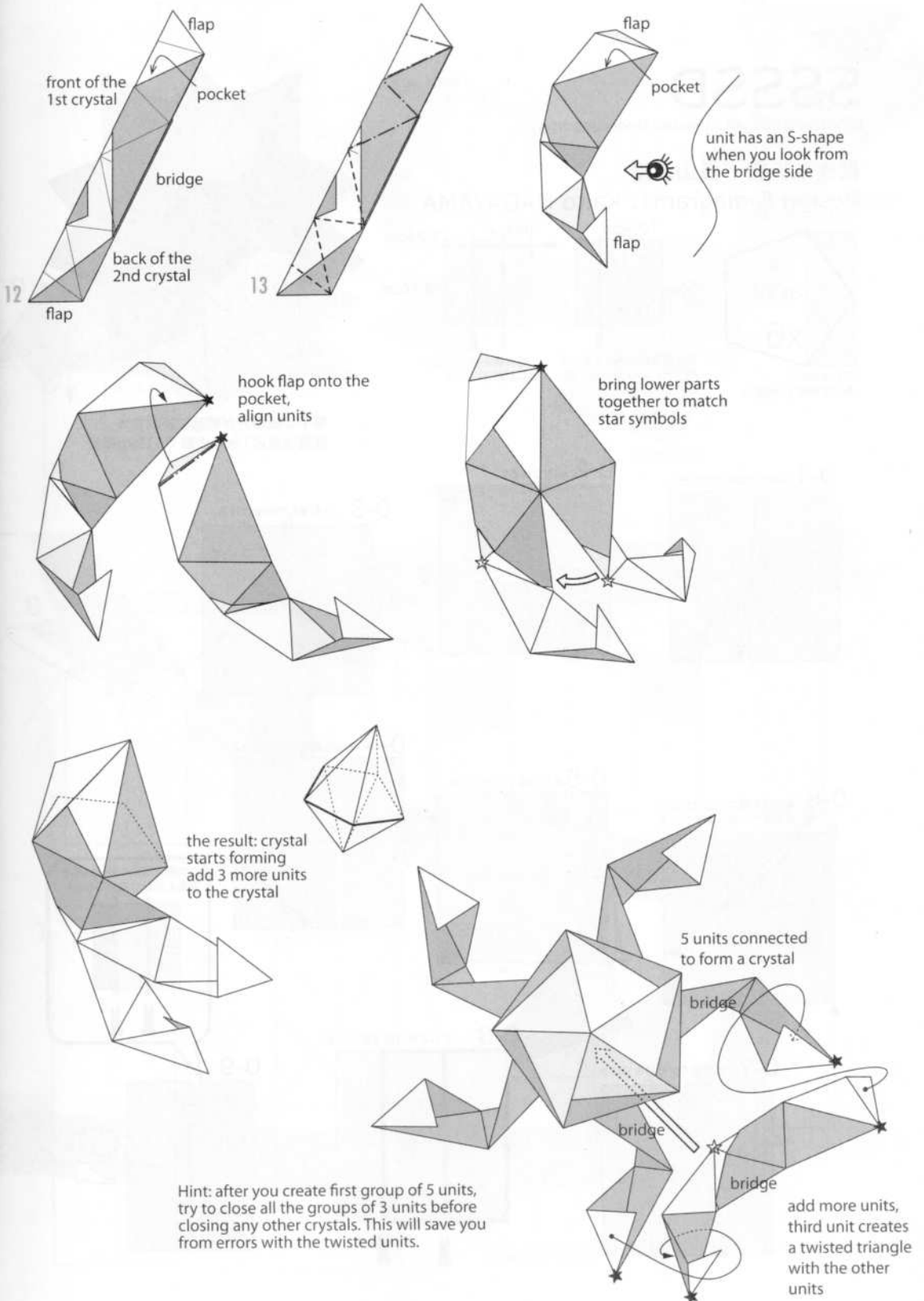

SSSSD

(Six-Sheets Small Stellated Dodecahedron)

創作 & 折図 : 長山海澄

Design & diagrams: Kaito NAGAYAMA

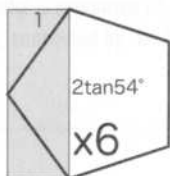
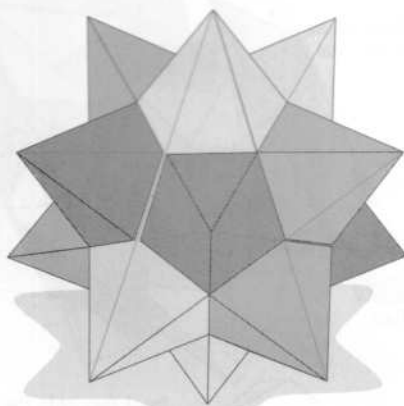

1:2tan54°の
長方形用紙を6枚使う

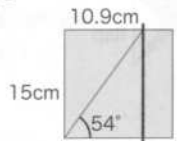

長さあるいは角度を計って
切り出してもよい(→0-8)

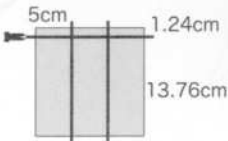

三等分線を使うと紙の
無駄が減る(→0-9)

厚手の紙の方が綺麗に折れます
推奨は長辺15cmの紙で110kg程度

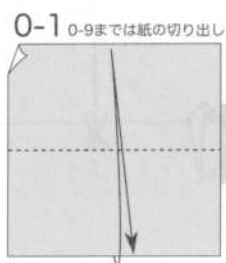

0-1 0-9までは紙の切り出し

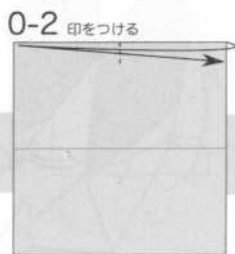

0-2 印をつける

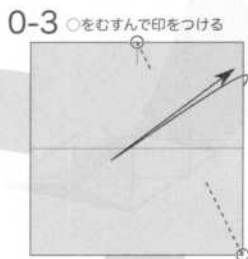

0-3 ○をむすんで印をつける



0-6 ▲の点を軸に○の点が印に
乗るように折り筋をつける

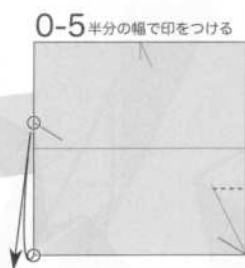

0-5 半分の幅で印をつける

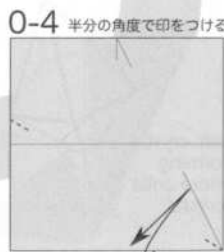

0-4 半分の角度で印をつける

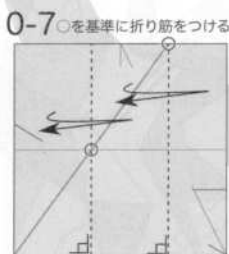
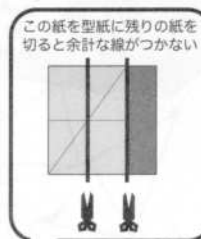

0-7 ○を基準に折り筋をつける

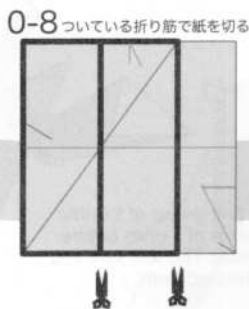

0-8 ついている折り筋で紙を切る

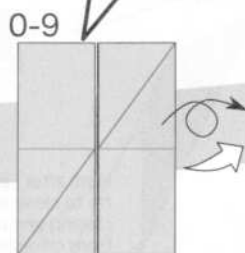

0-9

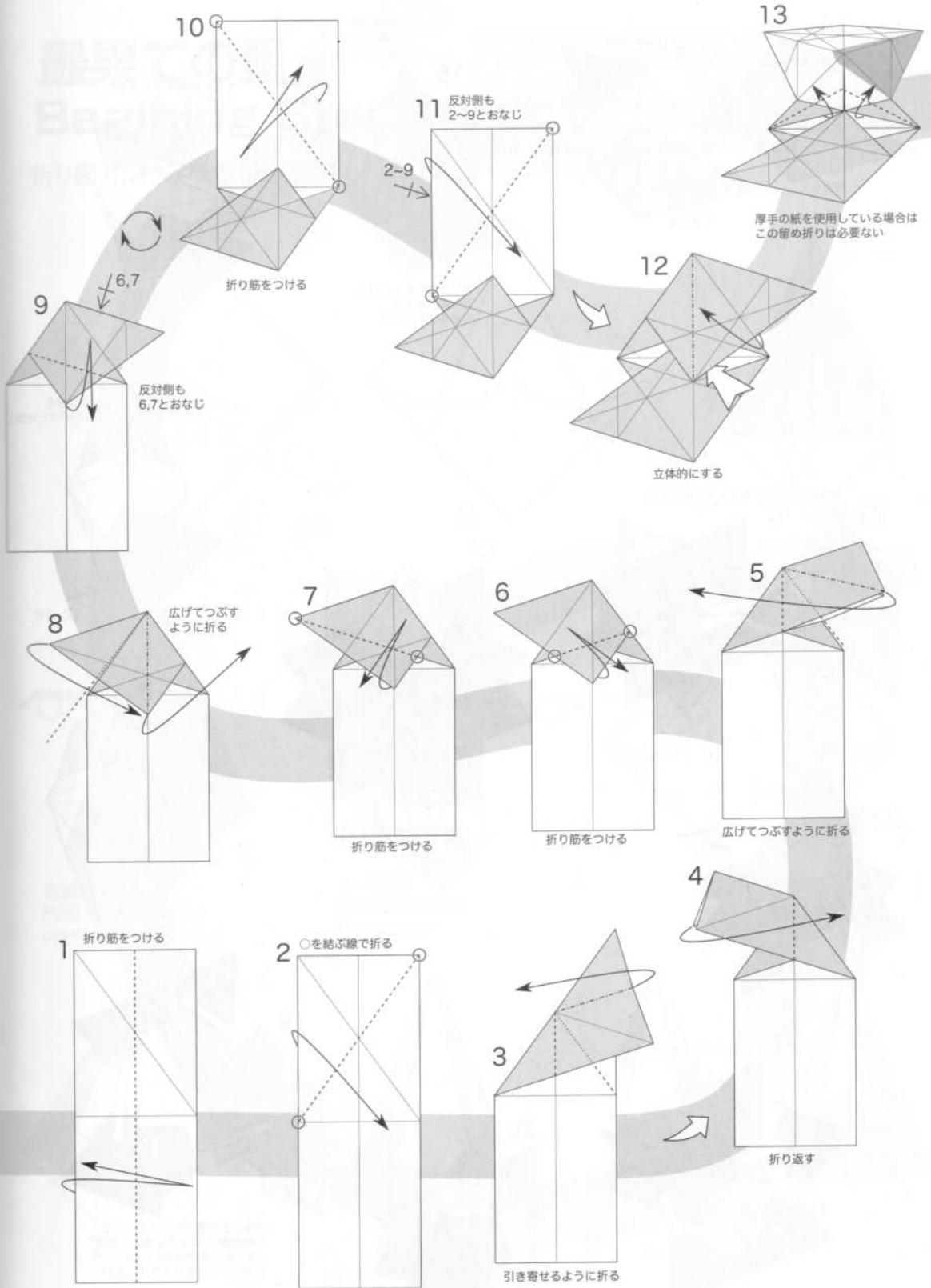

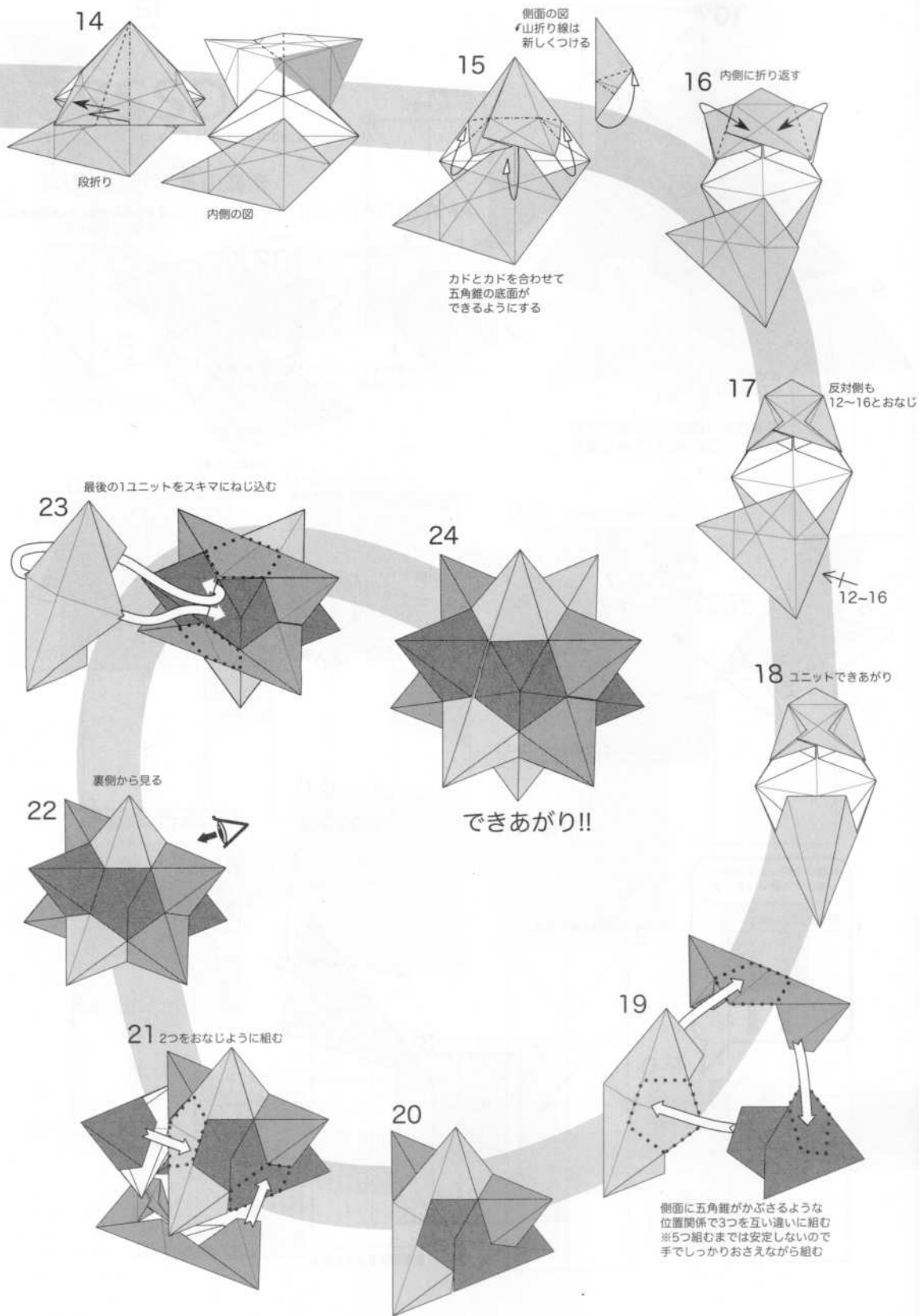

最果ての星 Begining Star

折り図・川村みゆき Miyuki Kawamura

2023年10月6日創作の作品です。中央がおへそのように
出っ張って、そこから出るヒダがビッグバンのように見え
たので、この名前にしました。

It was created on October 6th, 2023. I chose
this name because the center protrudes like a
navel, and the strips that come out from it look
like Big Bang.

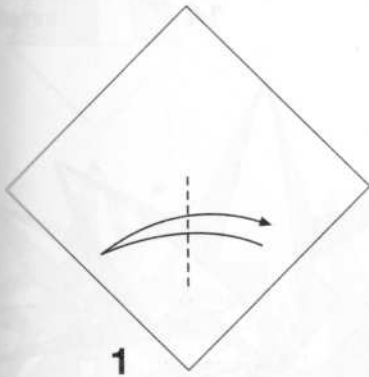

1

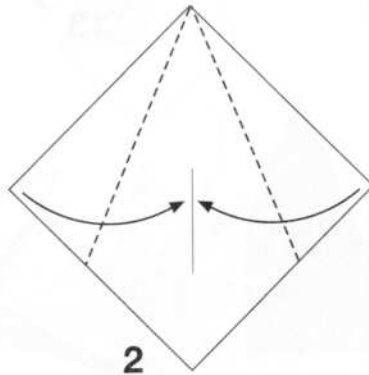

2

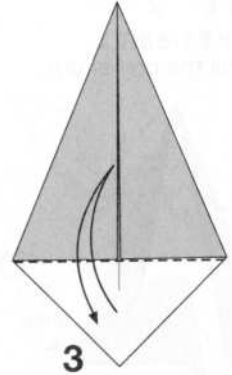

3

折り目をつける。
Fold and unfold

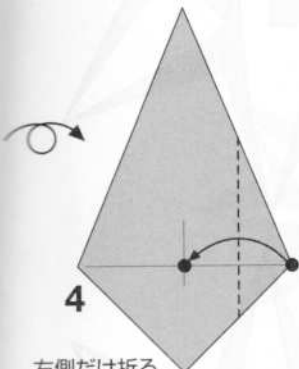

4

右側だけ折る。
Fold only the right
corner.

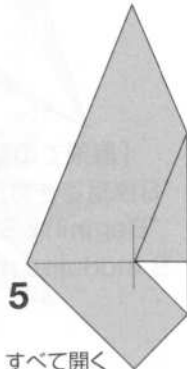

5

すべて開く
Unfold back to
the square.

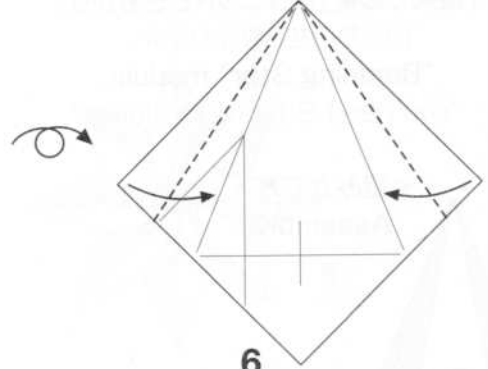

6

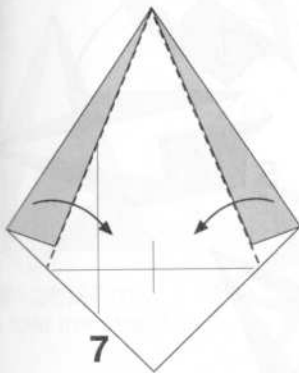

7

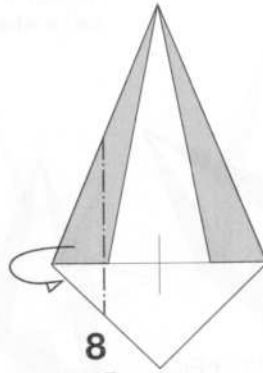

8

ついている
折り目で山折り。
Mountain fold
along the crease.

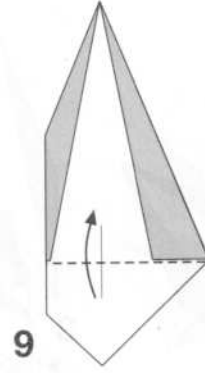

9

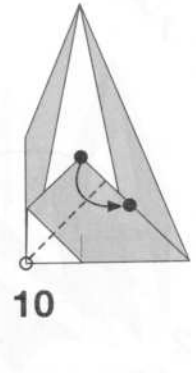

10

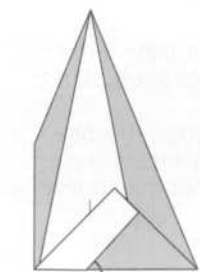

11
カドを引き出す。
Pull the corner out.

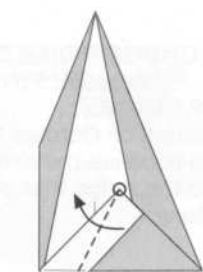

12

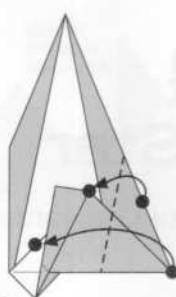

13

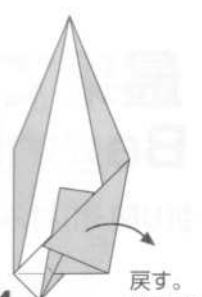

14
戻す。
Unfold

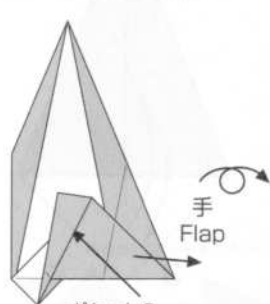

ポケット2
Pocket 2



裏側
Back side

「最果ての星」のユニットできあがり。

同じものを8枚作ります。

“Begining Star” module.

You need 8 same modules.



「最果ての星」

8枚組できあがり。

“Begining Star”

8 modules model

＜組み立て方＞

Assembly

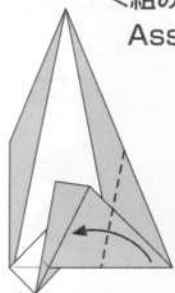

軽く折る。
Fold along
the crease.

1

以下、同様に
組んでいく。
Repeat the
same steps.

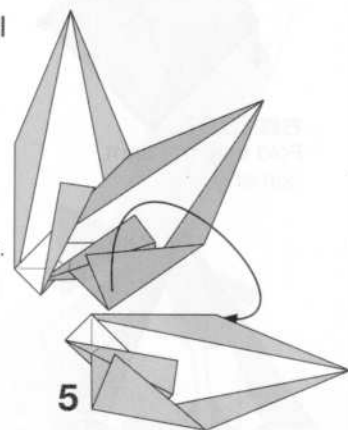

5

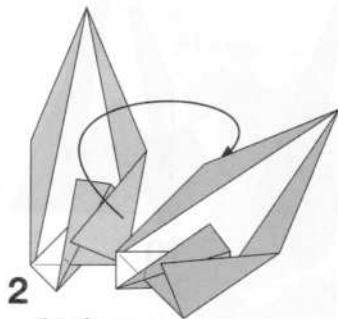

手をポケット1に
差し込む。
Insert the flap
into the pocket 1.

2

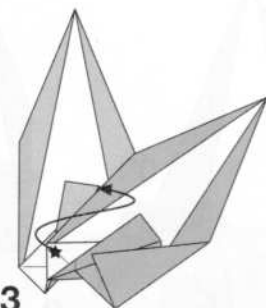

★印のカドをポケット2に
差し込む。
Insert the ★ coner
into the pocket 2.

3



4

<アレンジその1>
Arrangement 1

工程8までに左右のフラップの位置を変更すると、出来上がりのパターンが変わります。
If you change the position of the left and right flaps up to step 8, the finished pattern will change.

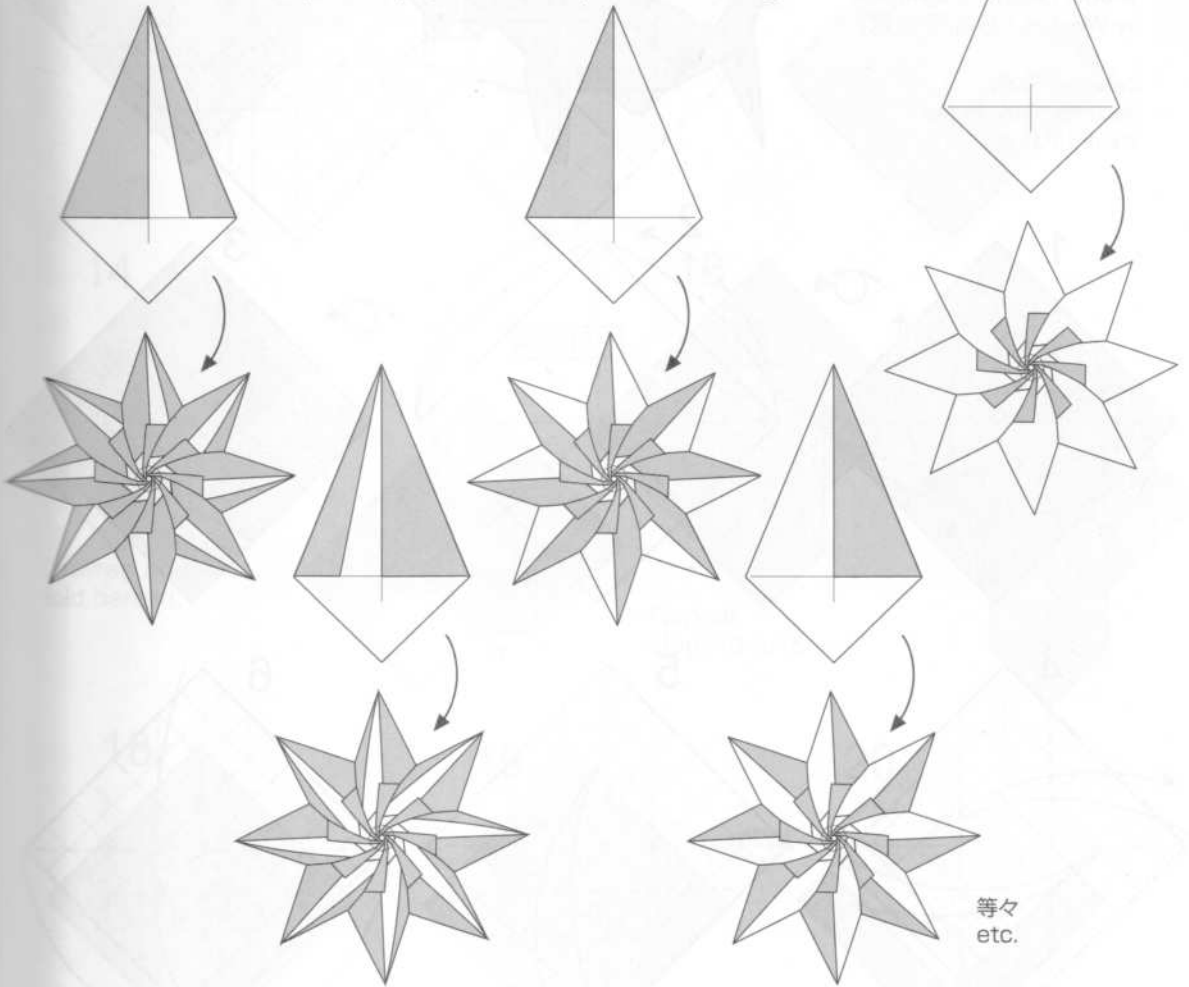

<アレンジその2>
Arrangement 2

工程12を折らない。
Un fold the step 12.

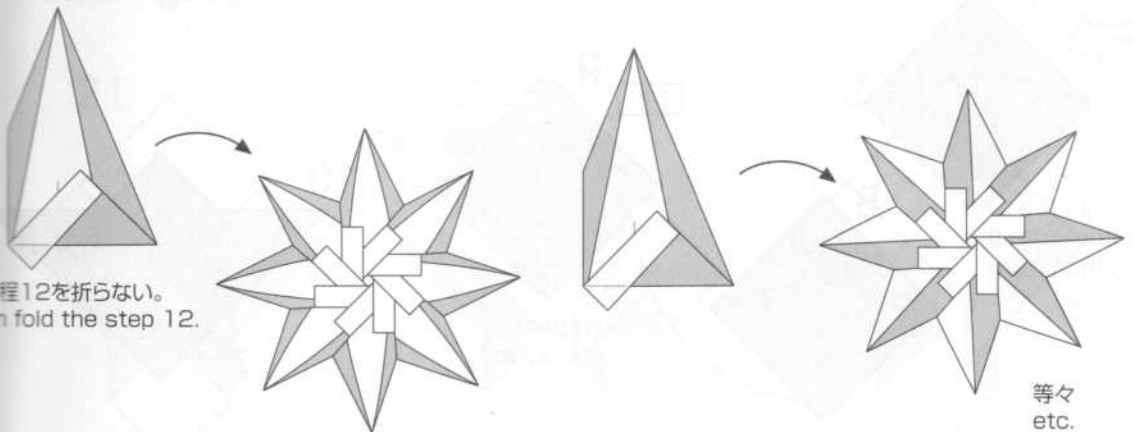

Shark

Model design & Diagram
by Wei Lin Chen(陳韋霖)

Designed:6/2024
Recommended Paper
-Kami 15*15 cm

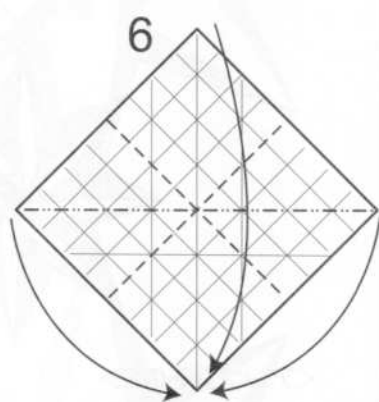
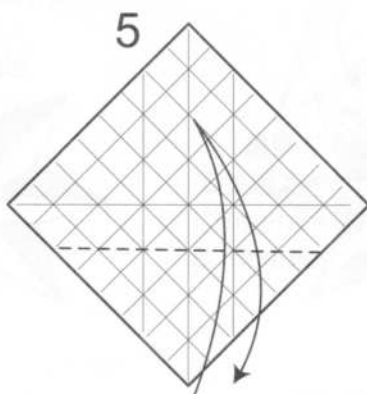
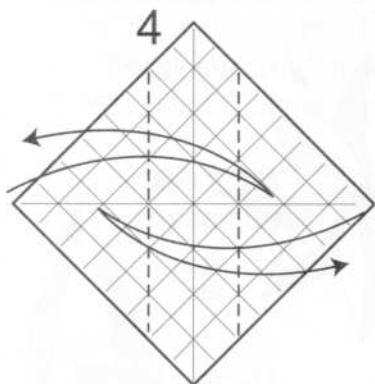
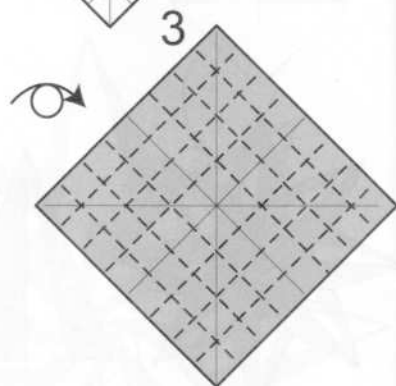
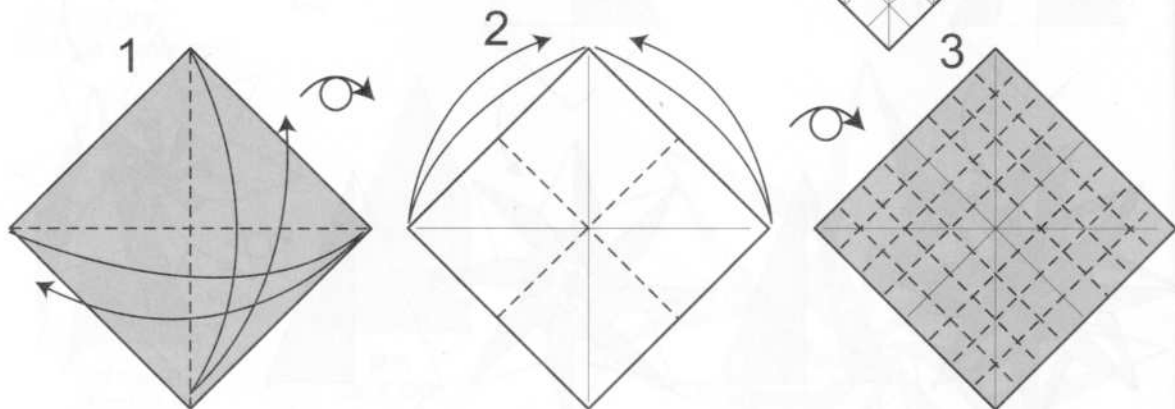
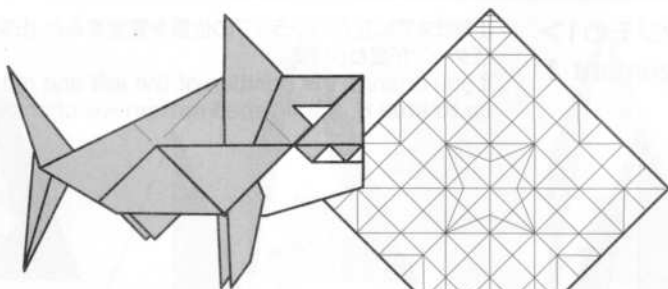

Fold a preliminary base using these creases.

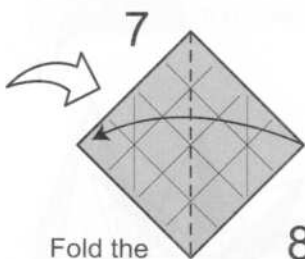

Fold the corner to the other side.

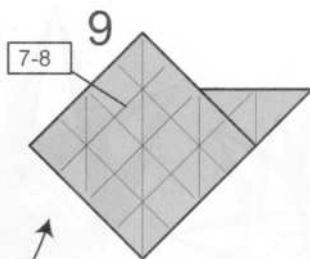
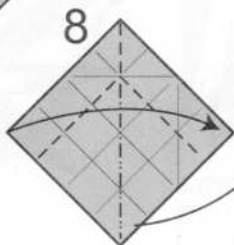

Repeat steps 7 to 8.

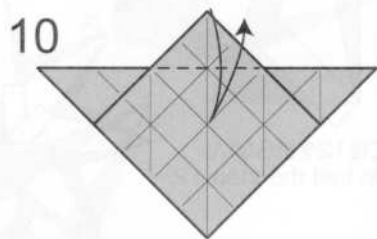

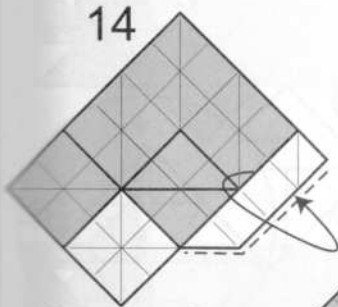
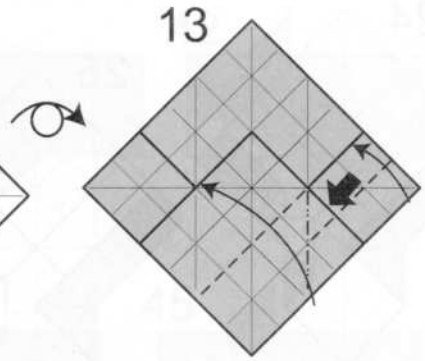
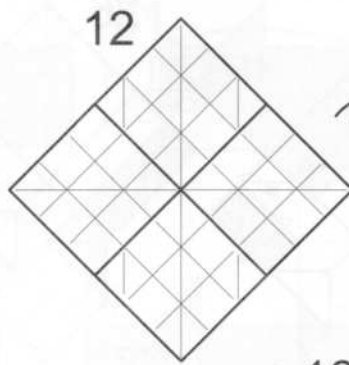
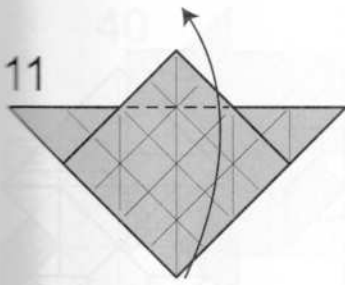

Unwrap and fold behind.

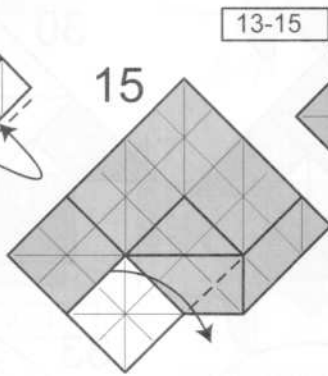

13-15

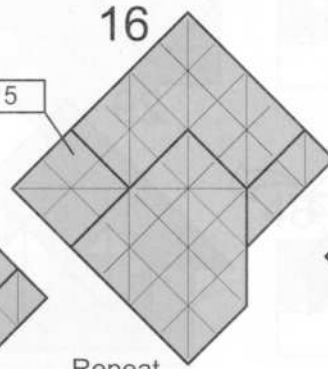

Repeat steps 13 to 15.

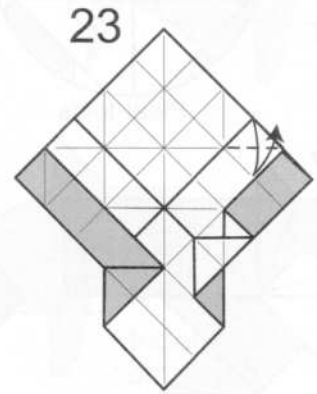
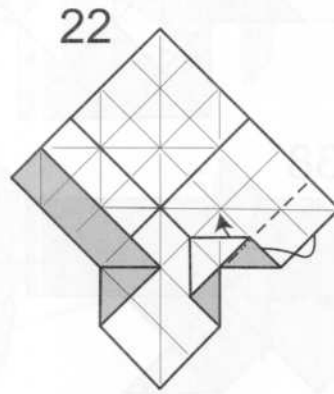
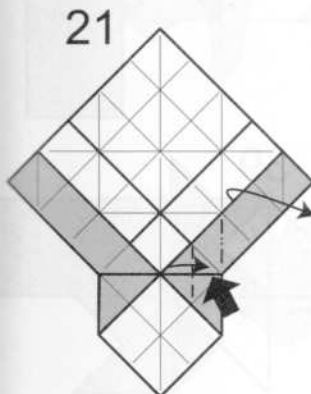
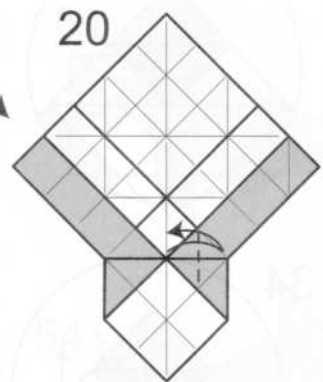
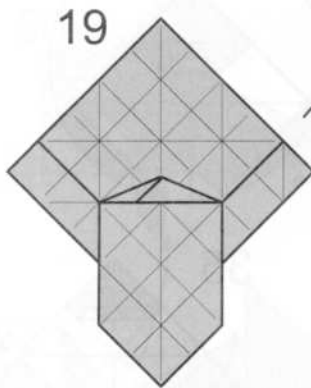
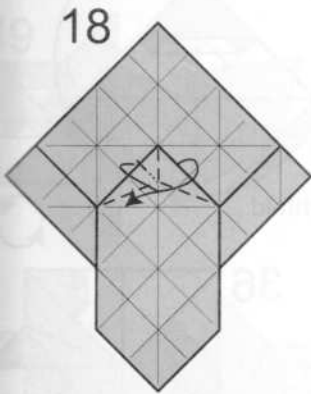
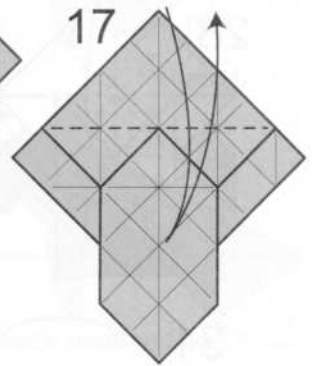

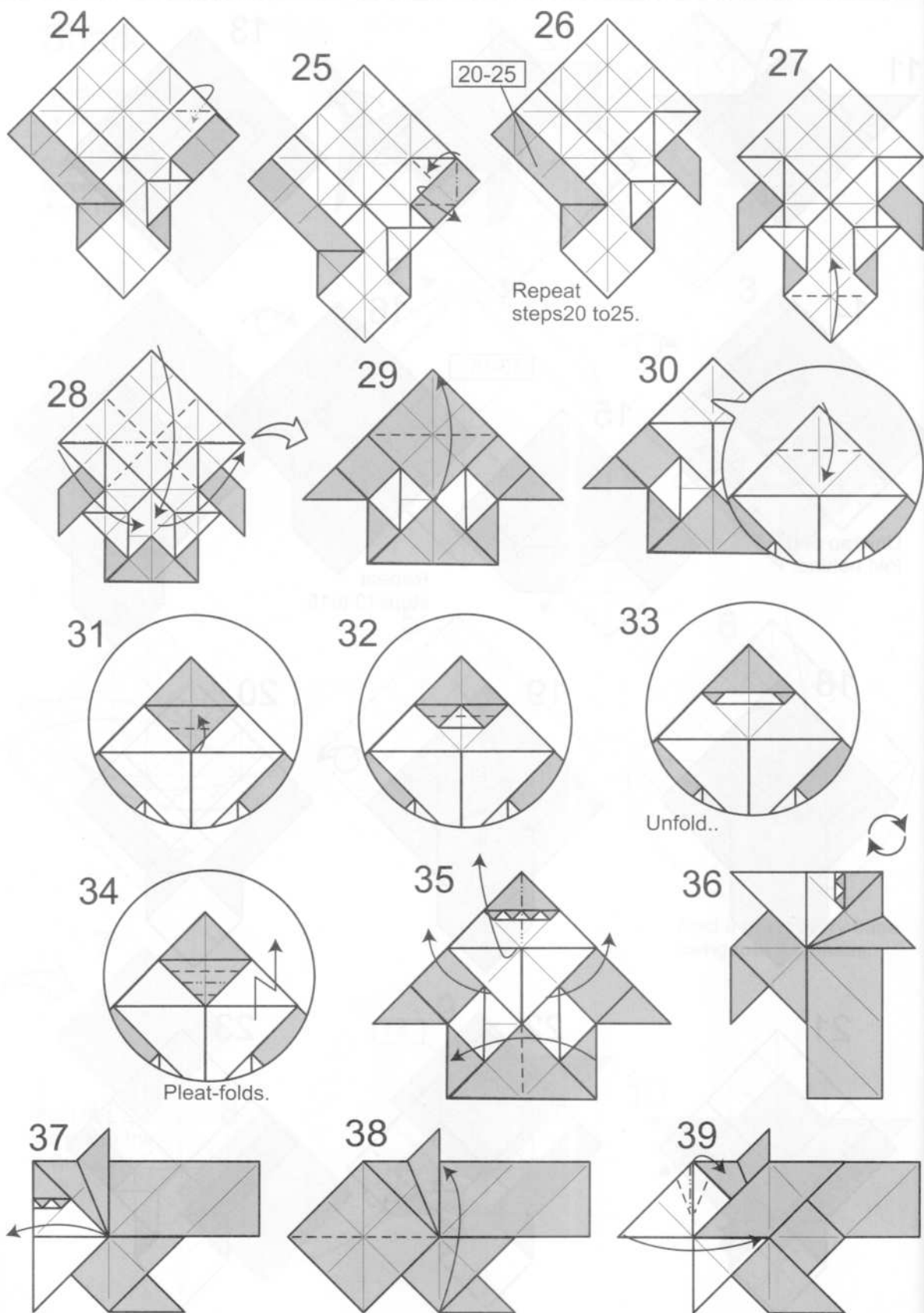

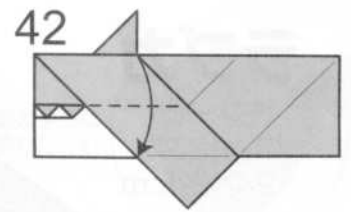
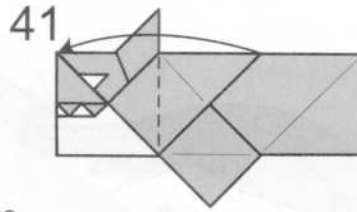
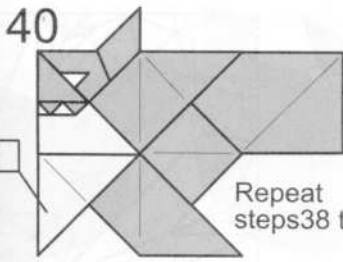

Repeat steps 38 to 39.

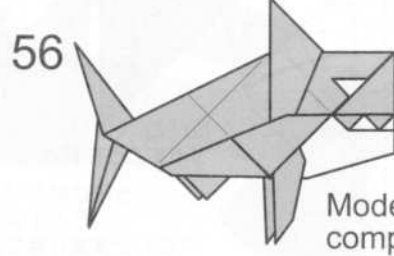
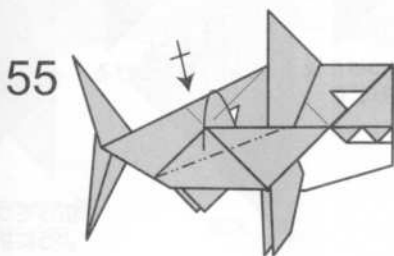
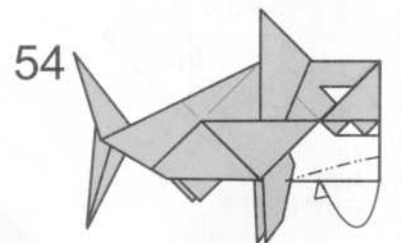
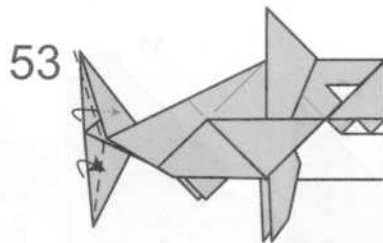
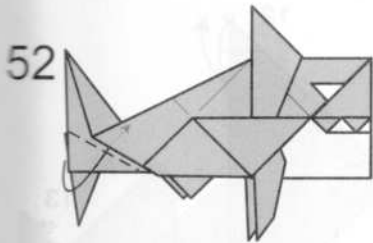
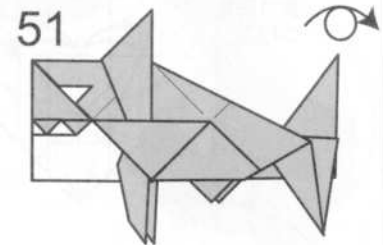
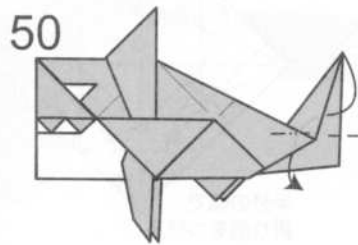
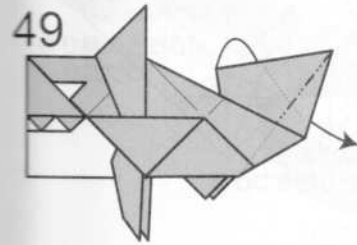
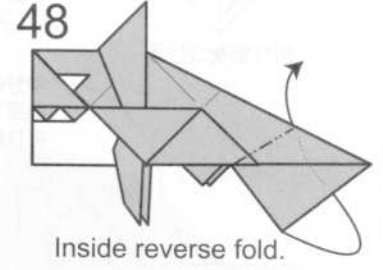
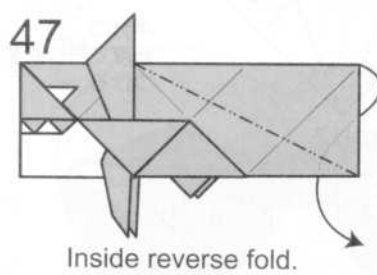
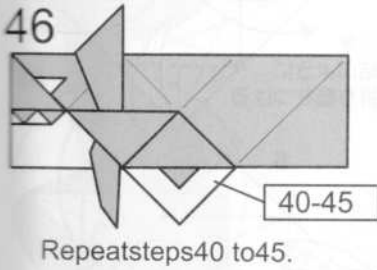
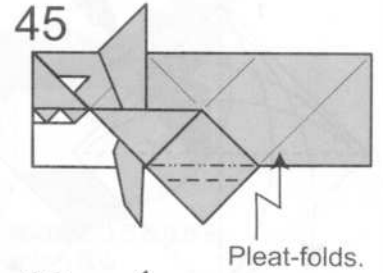
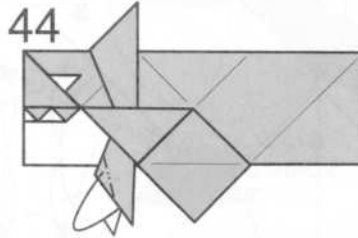
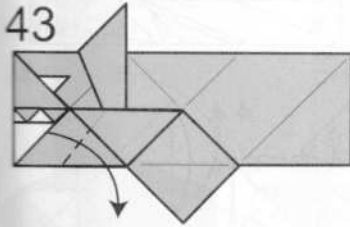

Model completed.

ラブカ

袋井一樹
2022.9
24×24cm

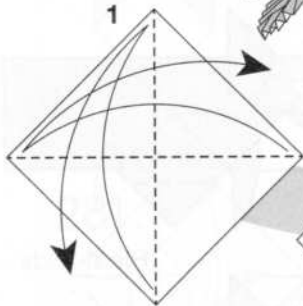
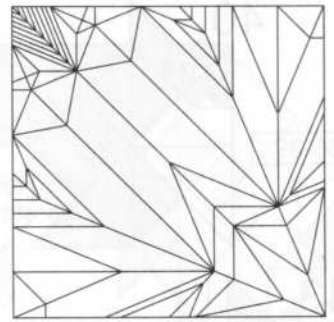
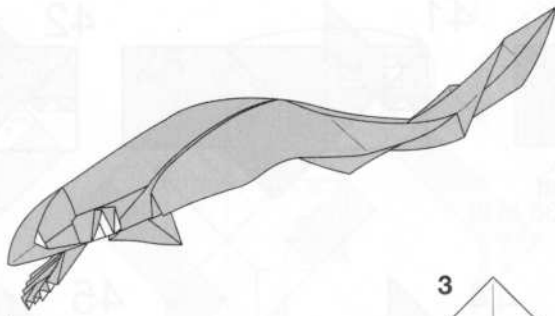

1
折り筋をつける

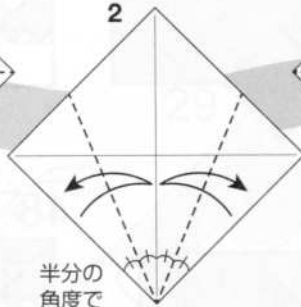

2
半分の
角度で
折り筋をつける

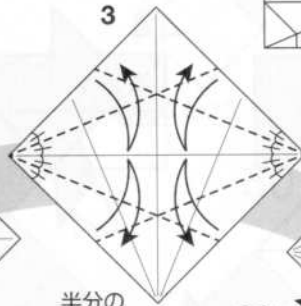

3
半分の
角度で折り筋を
つける

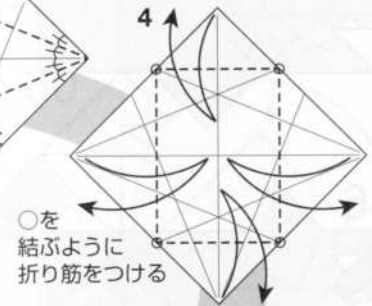

4
○を
結ぶように
折り筋をつける

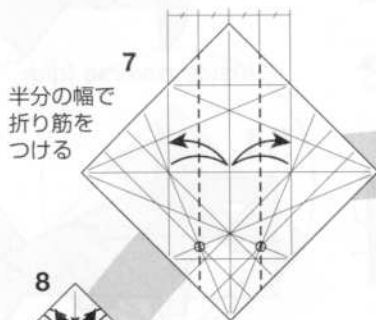

7
半分の幅で
折り筋を
つける

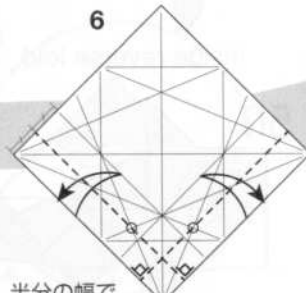

6
半分の幅で
折り筋をつける



5
○を
結ぶように
折り筋をつける

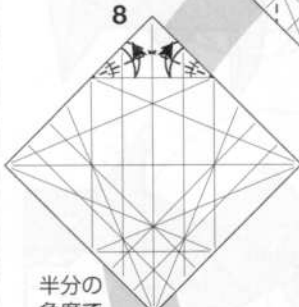

8
半分の
角度で
折り筋をつける

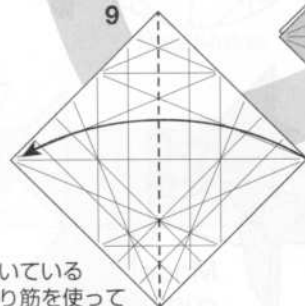

9
ついている
折り筋を使って
半分に折る

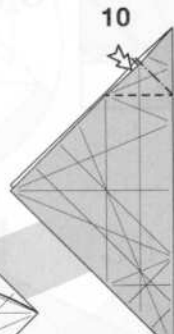

10
広げて
つぶすように折る

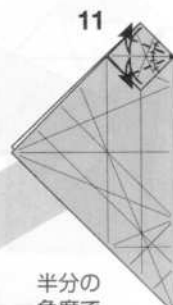

11
半分の
角度で
折り筋をつけた後
10までもどす

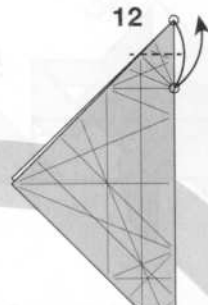

12
○を
結ぶように
折り筋をつける

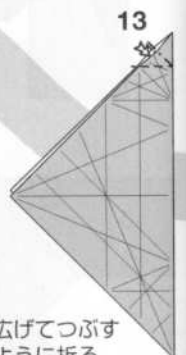

13
広げてつぶす
ように折る

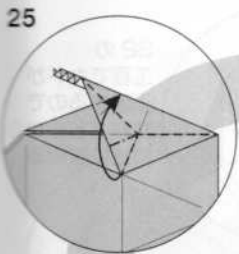

25
折り線のとおり
折りたたむ

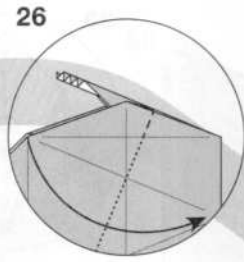

26
いっぱいところで
紙をめくる
(折り筋は
つけないで良い)

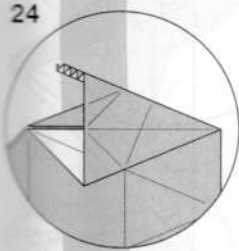

24
反対側も
19~22を
くり返す

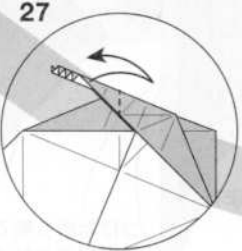

27
すでについている
折り筋をしっかりと
付けなおす

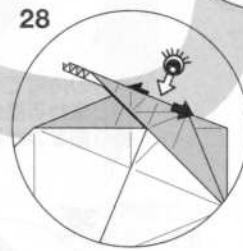

28
紙の層をひらきながら
上から見る

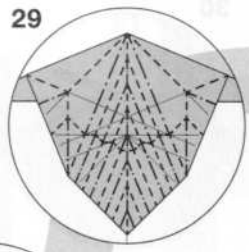

29
図のよう
に折りたたむ

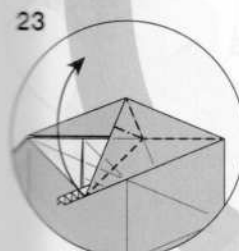

23
折り線のとおり
折りたたむ

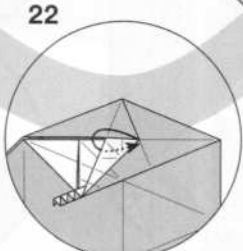

22
カドを裏側に
折り込む

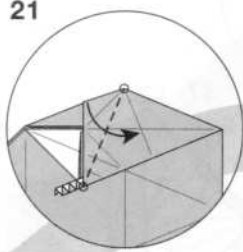

21
○を結ぶように
折る

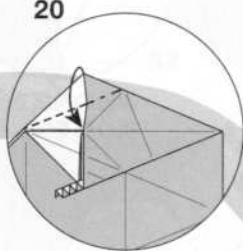

20
中割り折り

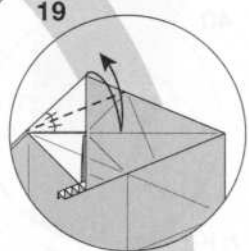

19
半分の角度で
折り筋をつける



14
半分の
角度で
折り筋をつけた後
10までもどす

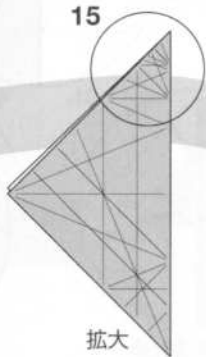

15
拡大

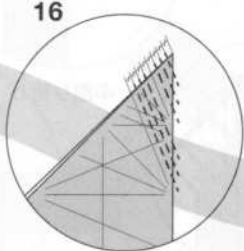

16
についている折り筋と
並行になるように
8等分の折り筋をつける

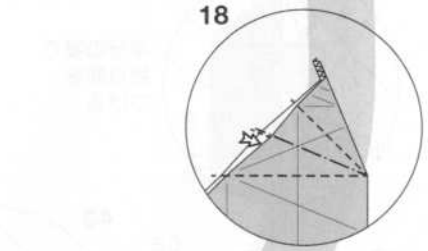

18
広げてたたむ
ように折る

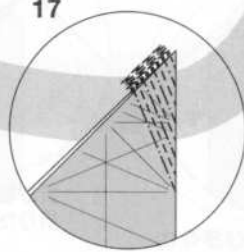

17
16でつけた
折り目を使って
両側で段折り

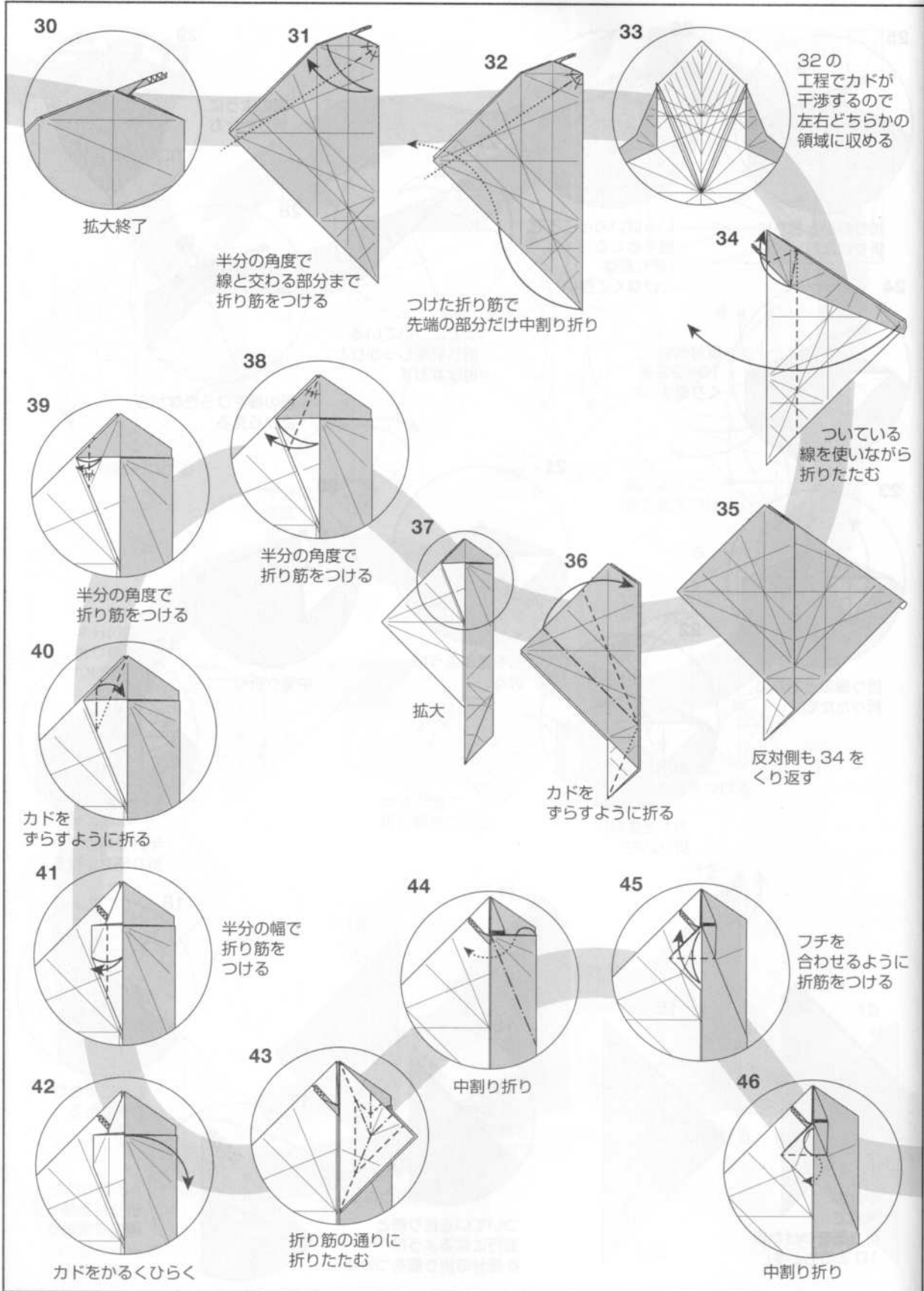

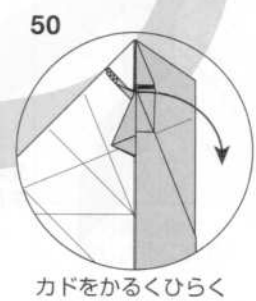
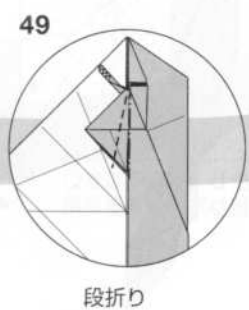
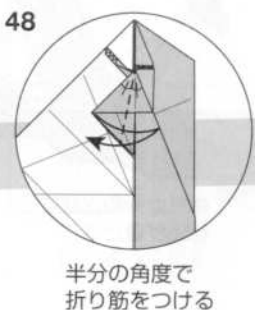
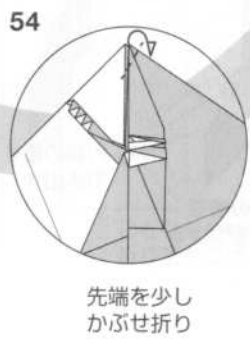
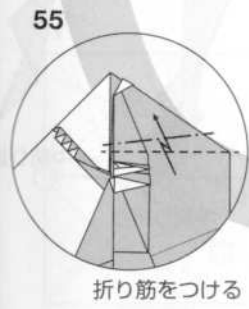
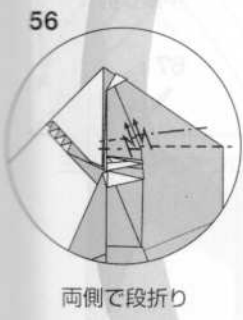
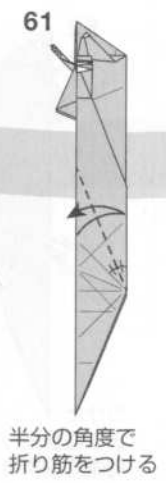
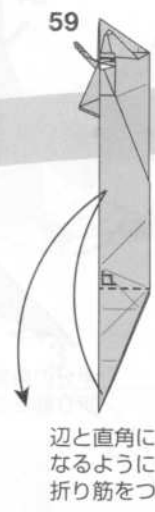
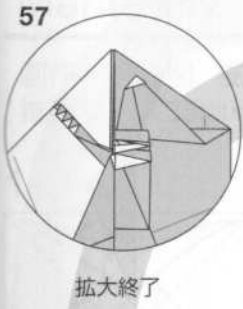

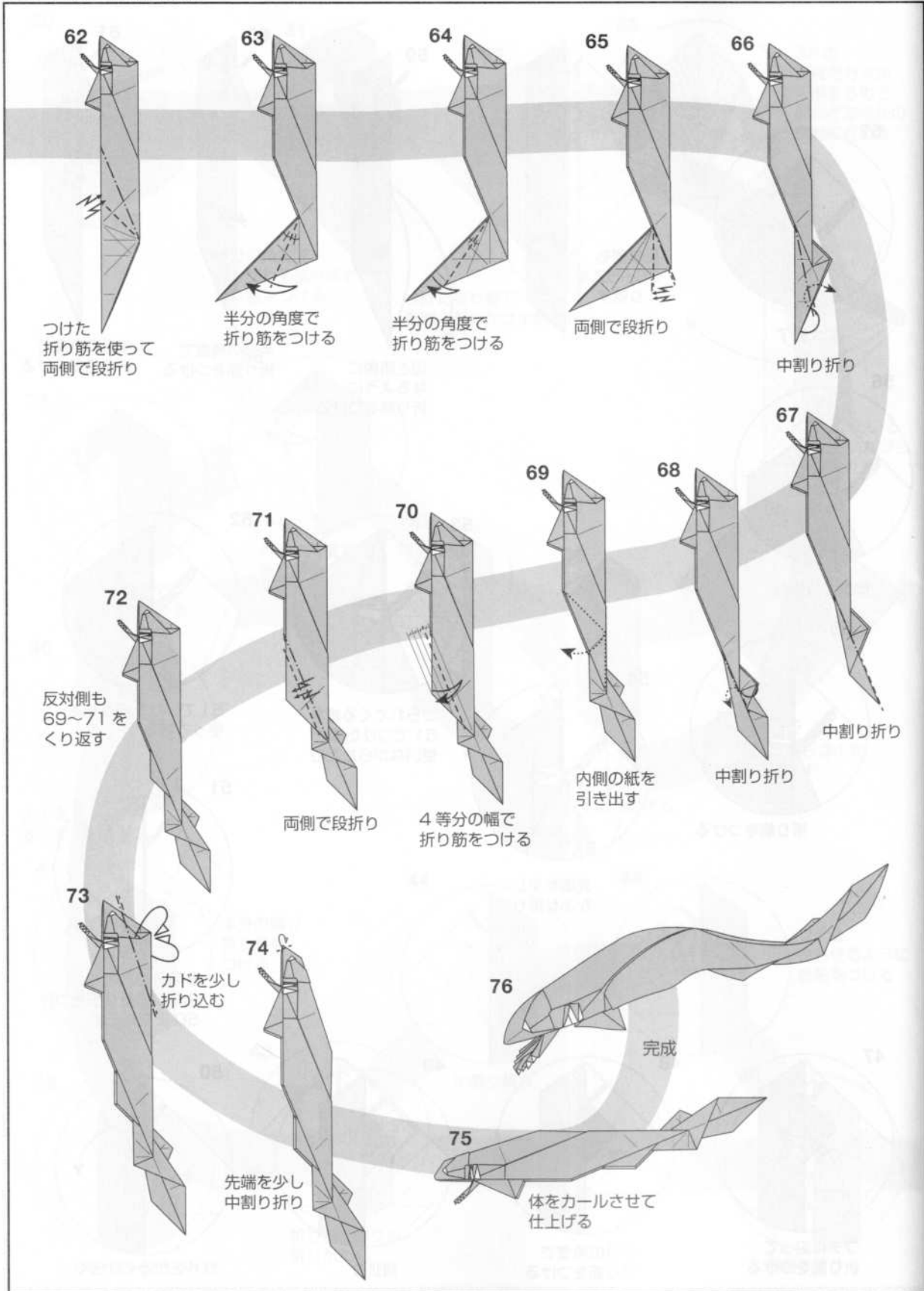

マンタ

Manta ray

創作・折り図 桃原瑞季
推奨サイズ35cm×35cm

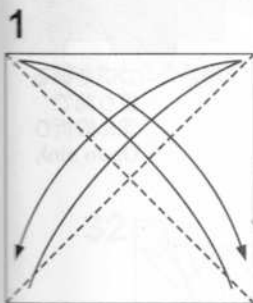
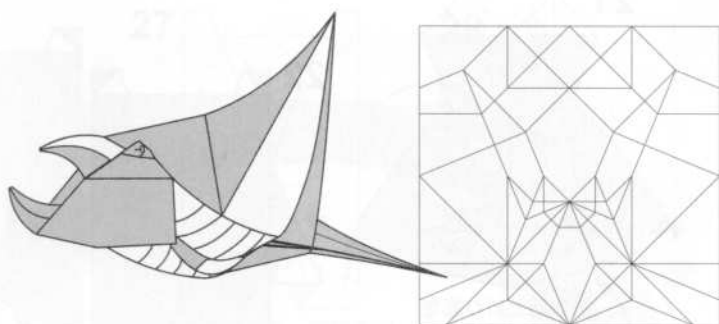

三角に折り筋をつける

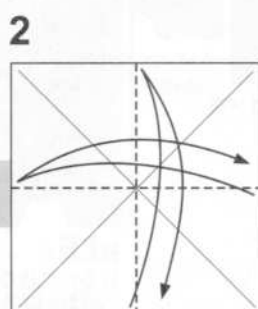

半分に折り筋をつける

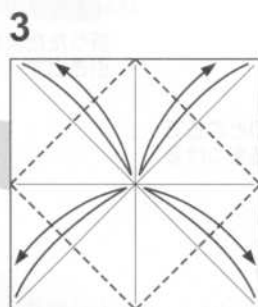

カドを中心に合わせて
折り筋をつける

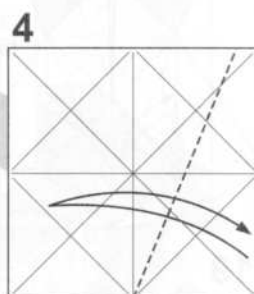

フチと折り筋を合わせて
折り筋をつける

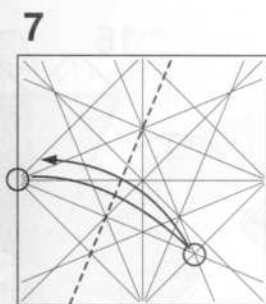

反対側も6と
同じように折る

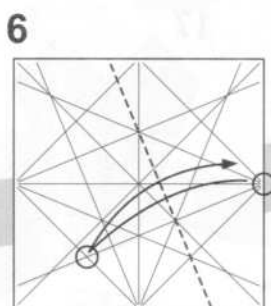

○と○を合わせて
折り筋をつける

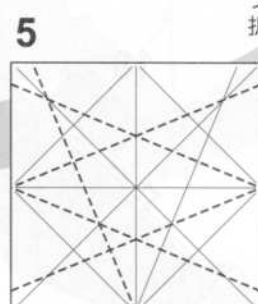

残りの5箇所も同じように
折り筋をつける

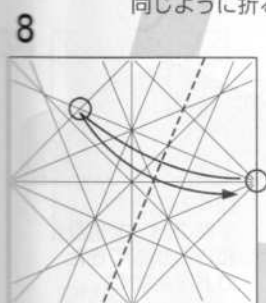

こちら側も6と
同じように折る

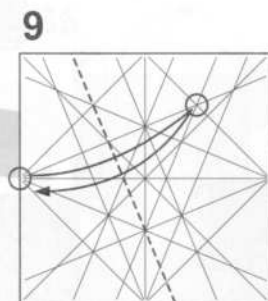

こちら側も6と
同じように折る

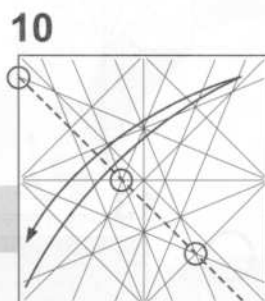

○を結ぶ線で
折り筋をつける

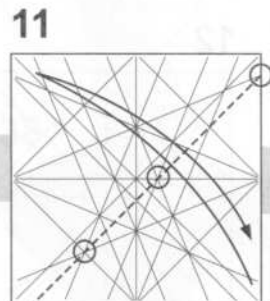

反対側も10と
同じように折る

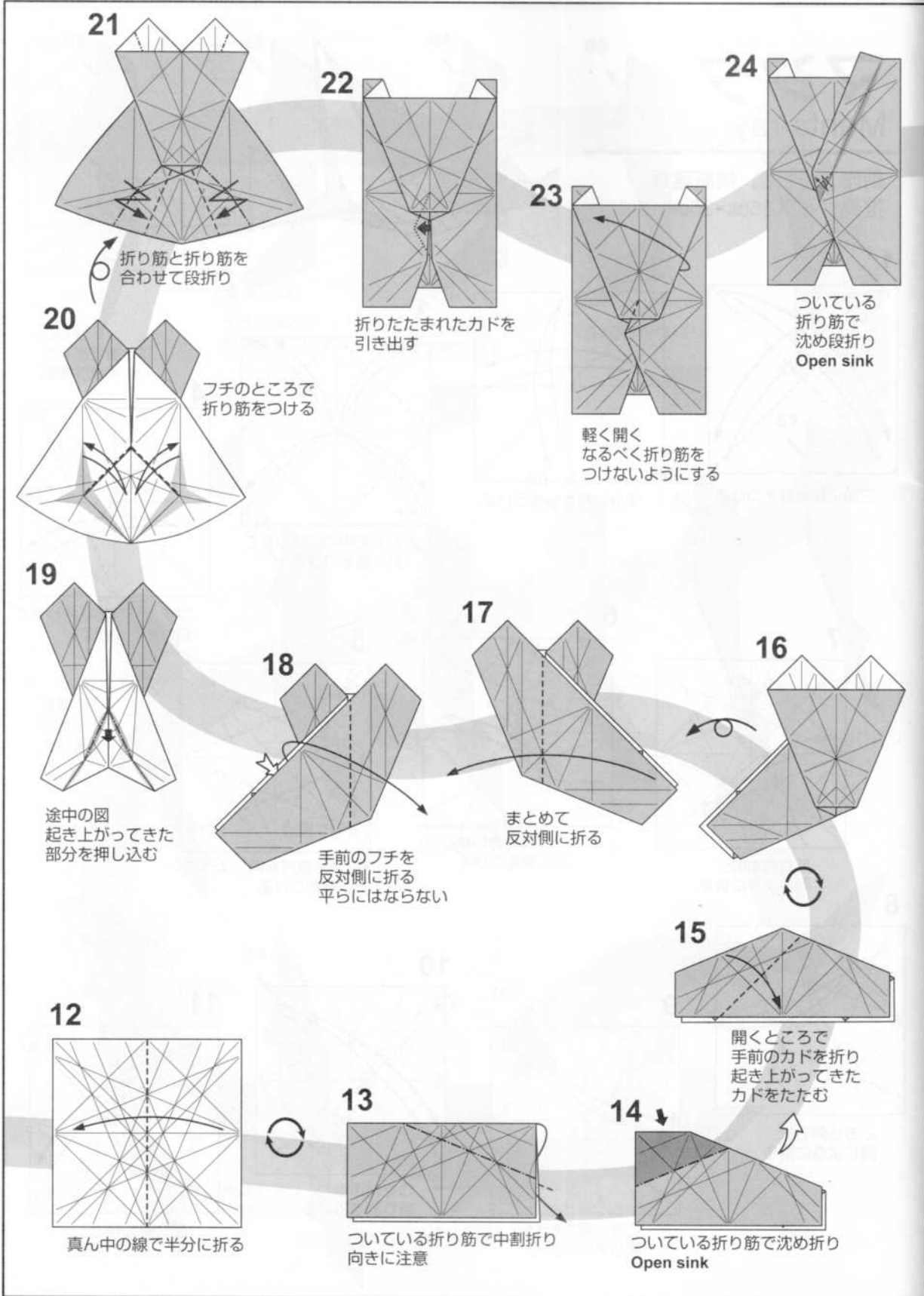

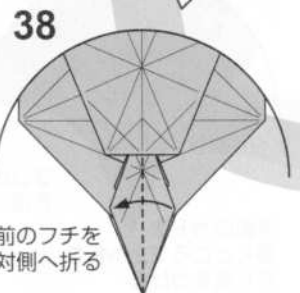
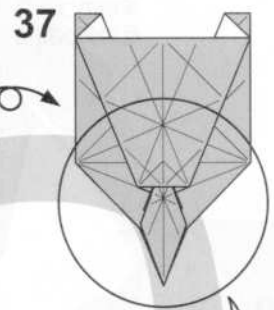
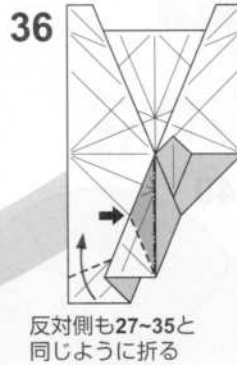
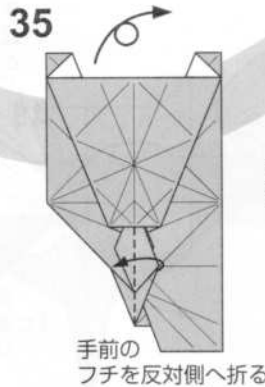
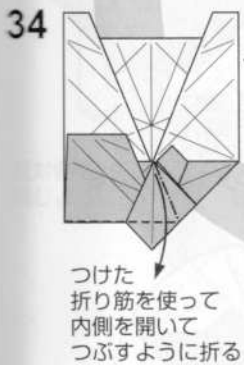
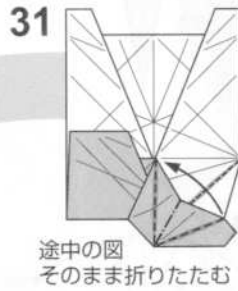
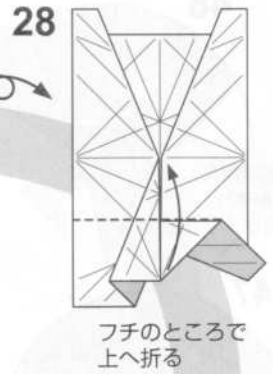
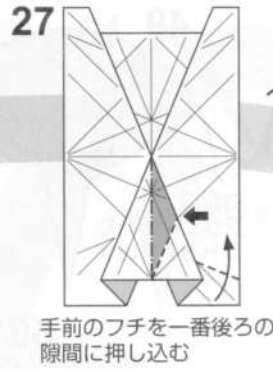
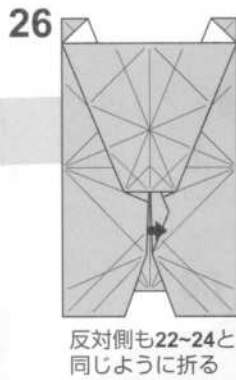

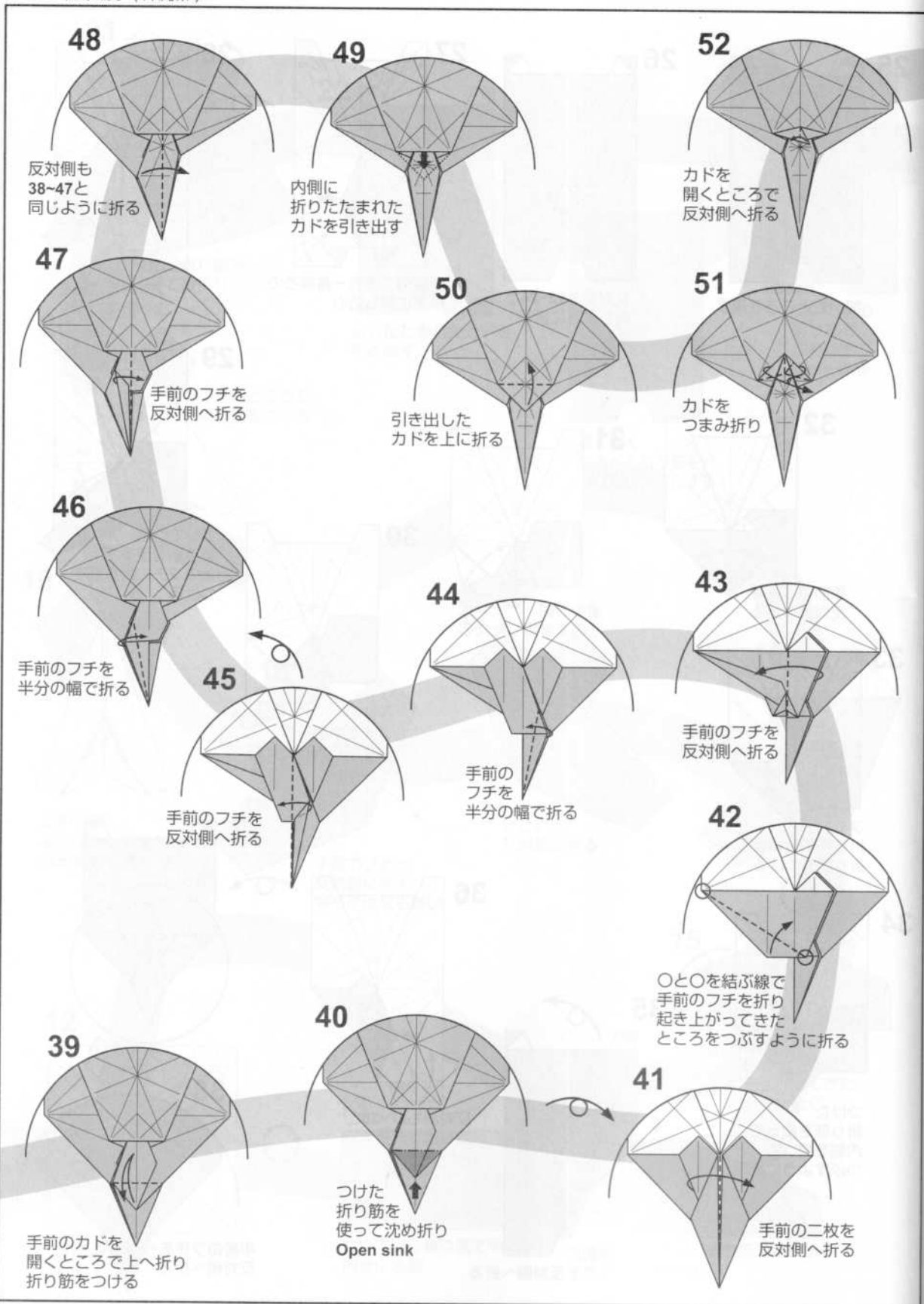



次の図からは
全体を示す

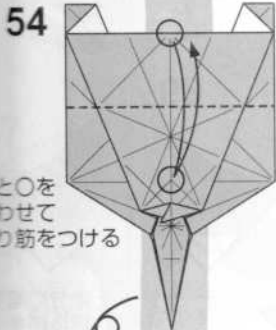

○と○を
合わせて
折り筋をつける

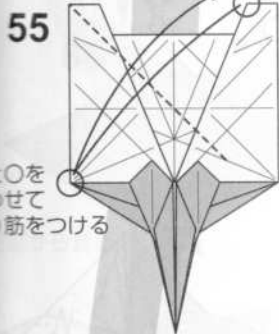

○と○を
合わせて
折り筋をつける

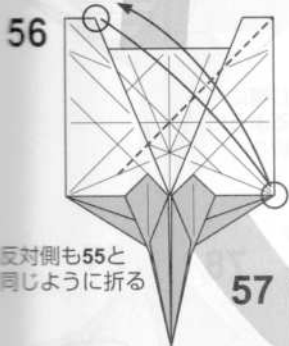

反対側も55と
同じように折る

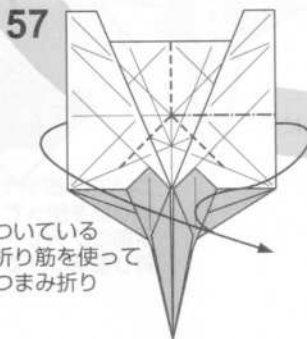

ついている
折り筋を使って
つまみ折り



そのまま
折りたたむ

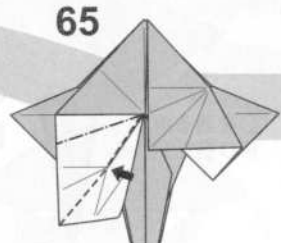

反対側も
62~64と
同じように折る



○と○を
合わせる
ように折る

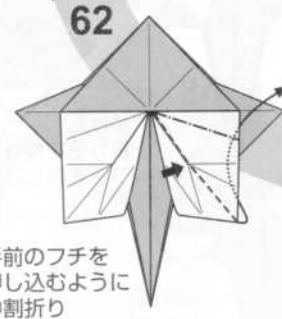

手前のフチを
押し込むように
中割り折り

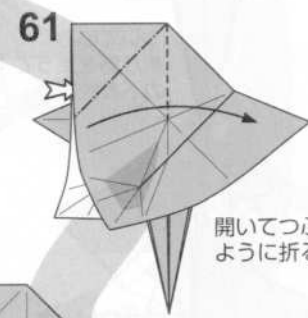

開いてつぶす
ように折る



こちら側も
58と同じように
折る



手前の2枚を
反対側へ折る

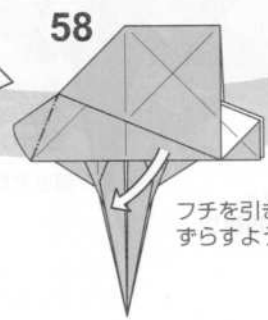

フチを引き出して
すらすらように折る

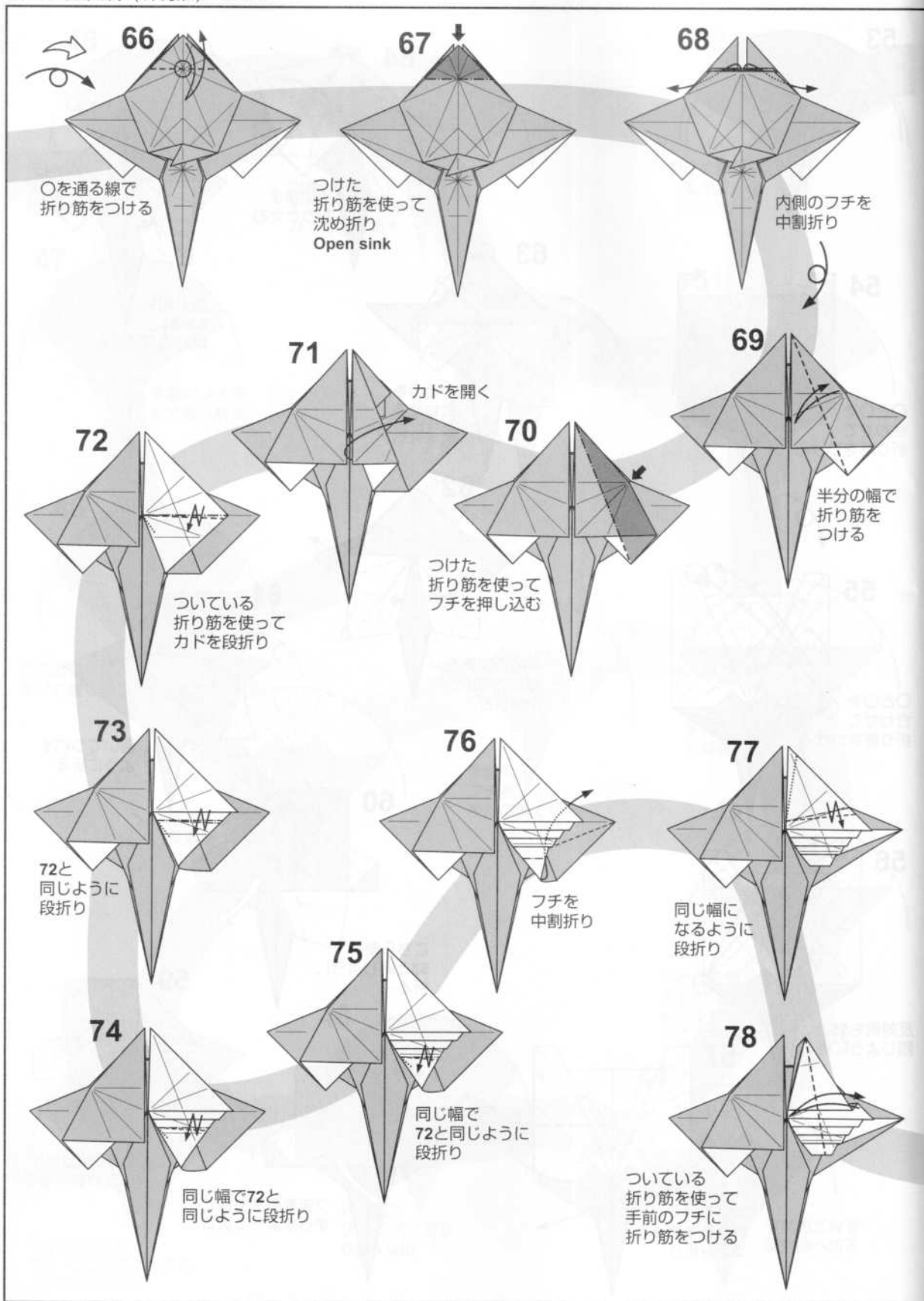

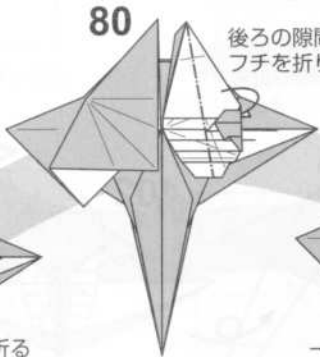
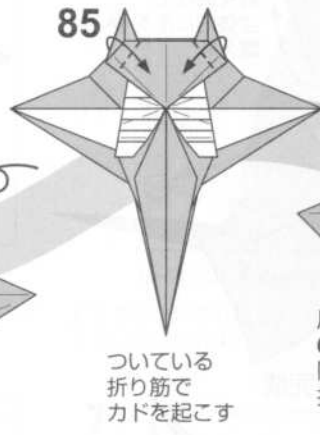
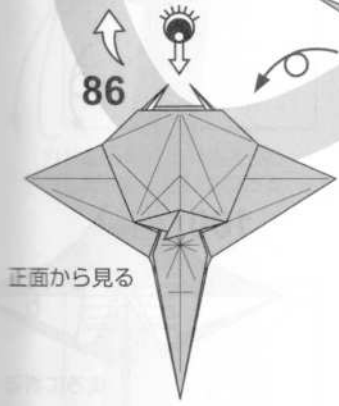
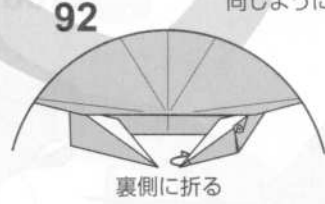
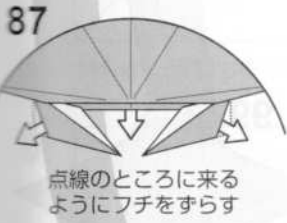
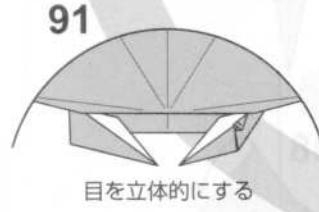
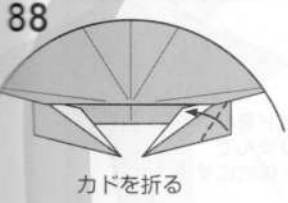
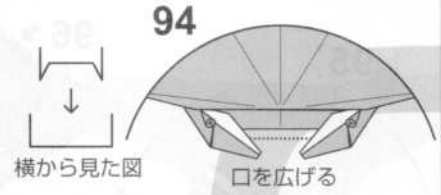

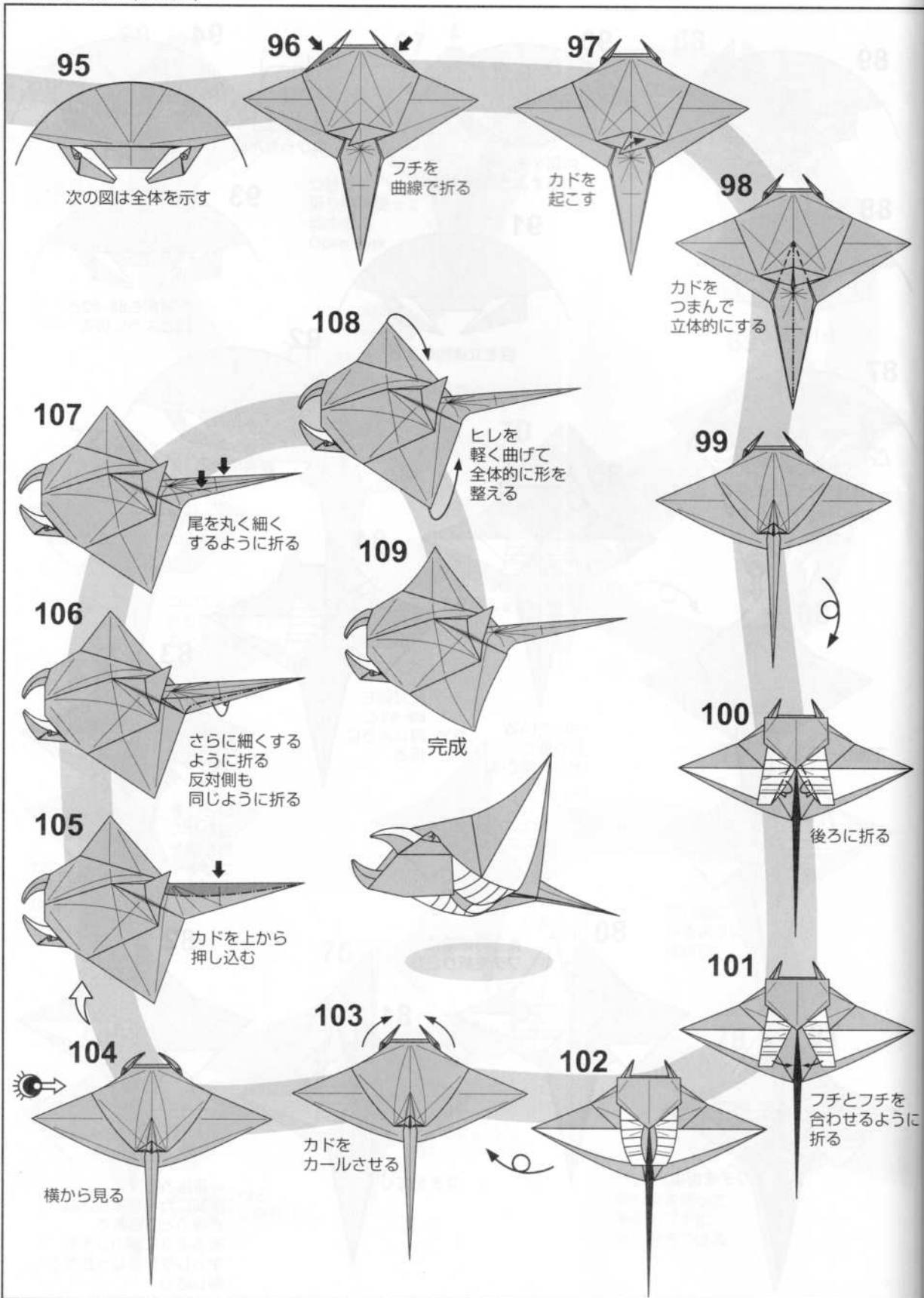

シュモクザメ

Hammer-head shark

創作：2024.02

創作・展開図： 稲吉秀尚

Model & Crease pattern
by Hidehisa Inayoshi

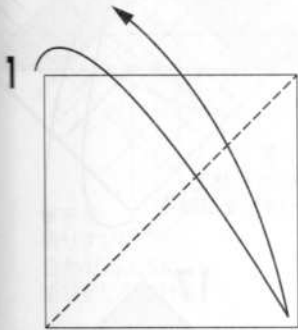
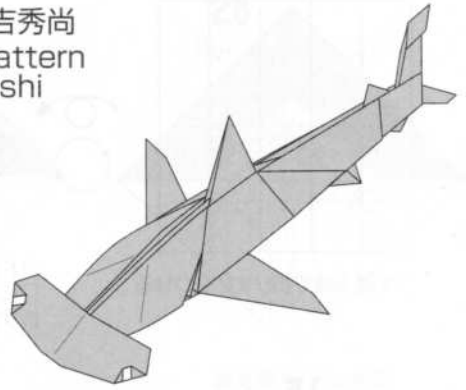

対角線に折りすじをつける

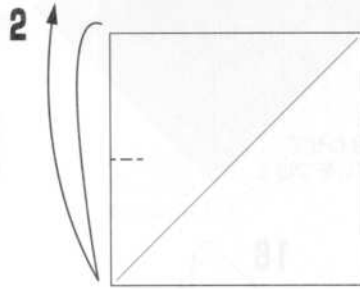

少しだけ折りすじをつける

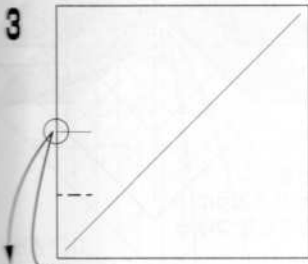

カドを○に合わせるように
少しだけ折りすじをつける

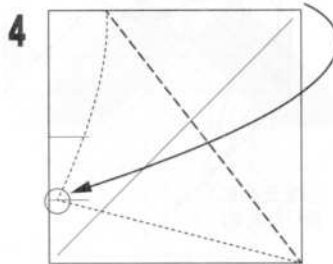

カドを○に合わせるように折る
(できるだけ折り目をつけないように
Try not to make crease as much as possible)

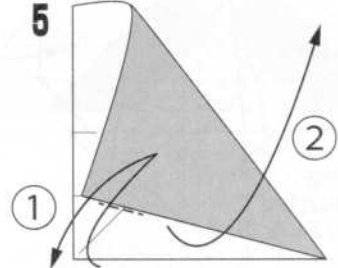

フチにそって、少しだけ
折りすじをつけてから、紙を開く

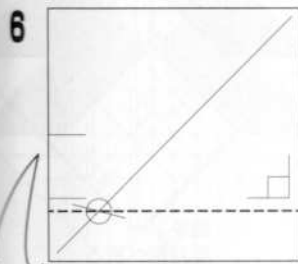

○を通る線で折りすじをつける

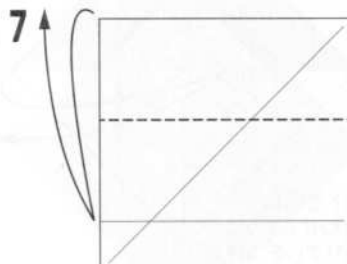

フチを折りすじに合わせるように
折りすじをつける

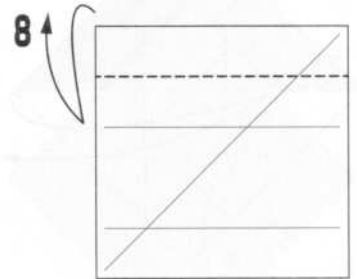

フチを折りすじに合わせるように
折りすじをつける



フチを折りすじに合わせるように
折りすじをつける

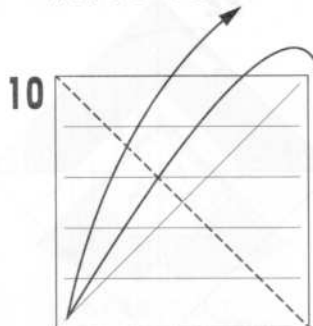

対角線に折りすじをつける

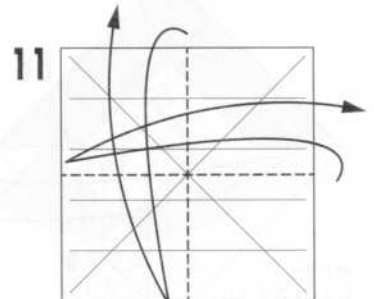

半分の折りすじをつける

12

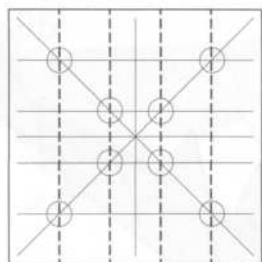

○を通る線で折りすじをつける

13

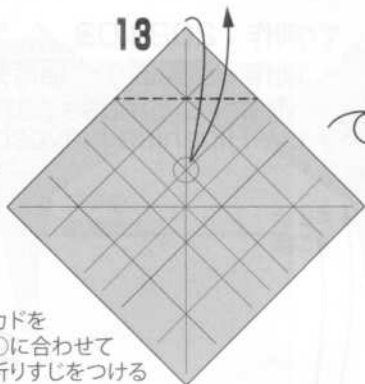

カドを
○に合わせて
折りすじをつける

14

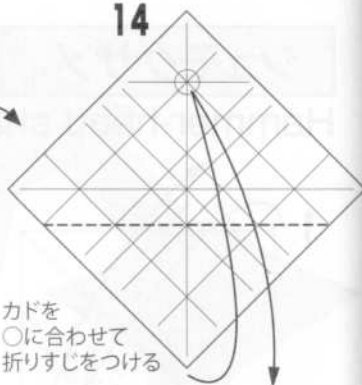

カドを
○に合わせて
折りすじをつける

15

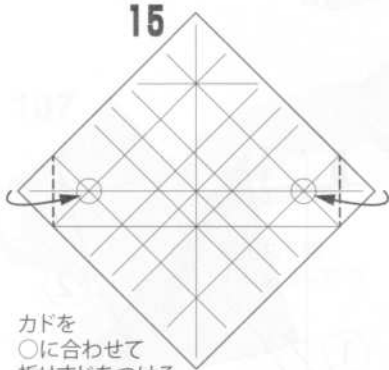

カドを
○に合わせて
折りすじをつける

16

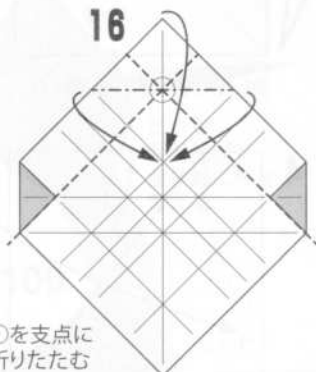

○を支点に
折りたたむ

17

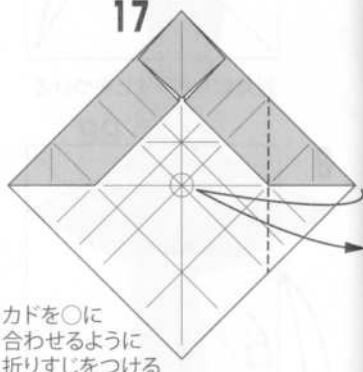

カドを○に
合わせるように
折りすじをつける

18

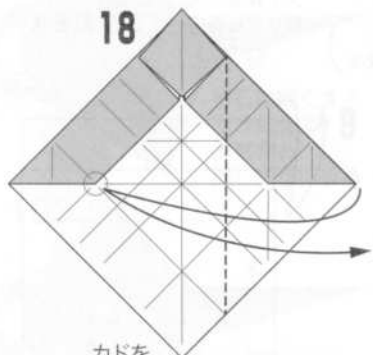

カドを
○に合わせて
折りすじをつける

19

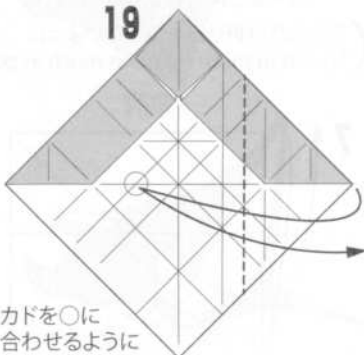

カドを○に
合わせるように
折りすじをつける

20

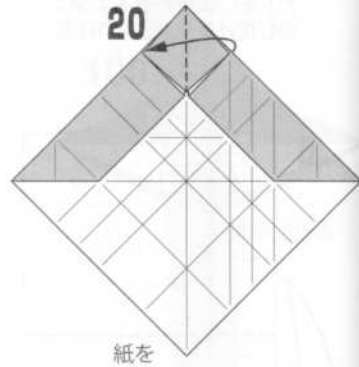

紙を
反対側へ折る

21

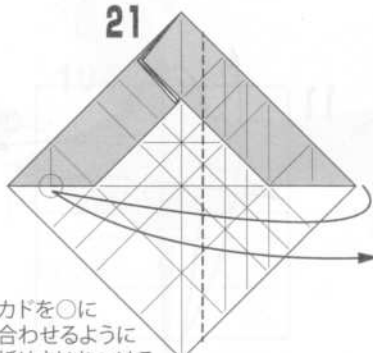

カドを○に
合わせるように
折りすじをつける

22



上の紙を
反対側へ折る

23

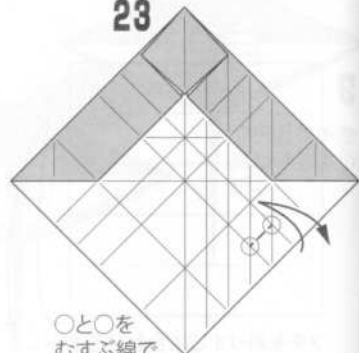

○と○を
むすぶ線で
折りすじをつける

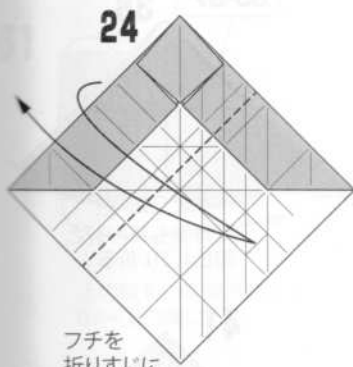

フチを
折りすじに
合わせるように
折りすじをつける

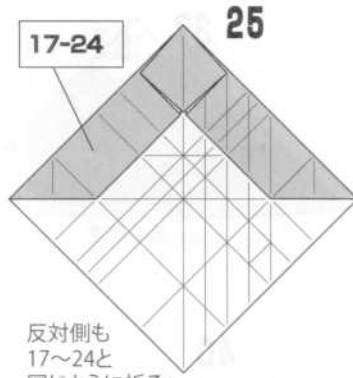

反対側も
17~24と
同じように折る

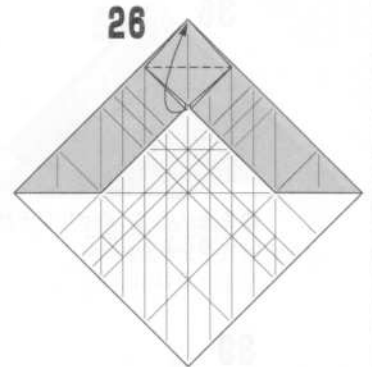

紙を開くように折る

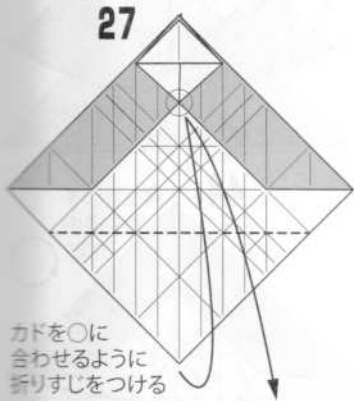

カドを○に
合わせるように
折りすじをつける

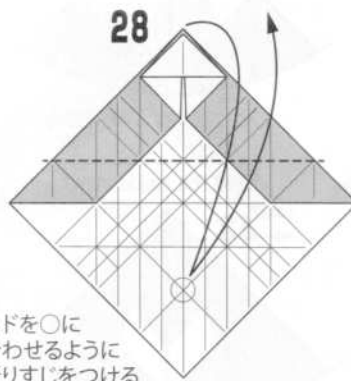

カドを○に
合わせるように
折りすじをつける

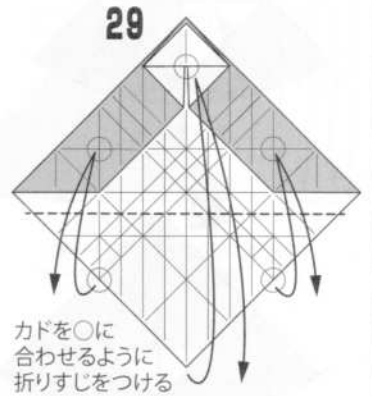

カドを○に
合わせるように
折りすじをつける

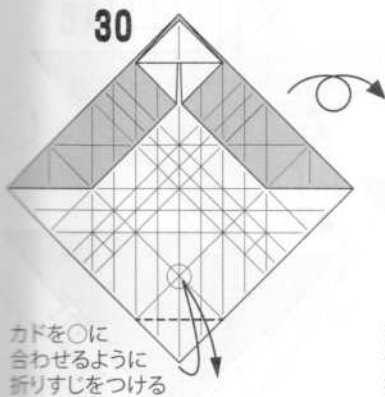

カドを○に
合わせるように
折りすじをつける

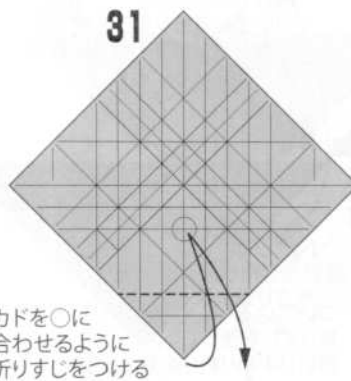

カドを○に
合わせるように
折りすじをつける

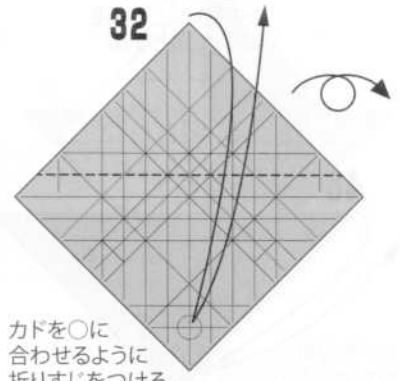

カドを○に
合わせるように
折りすじをつける

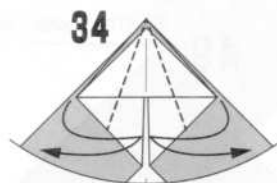
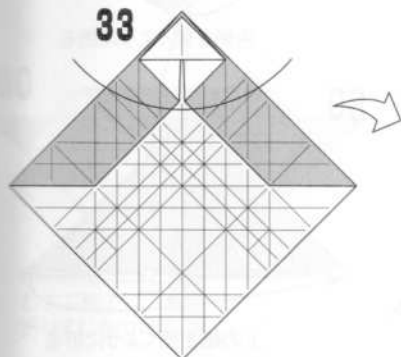

カドを支点にして、
折りすじをつける



●を支点にして、
カドを○に
合わせるように
折りすじをつける

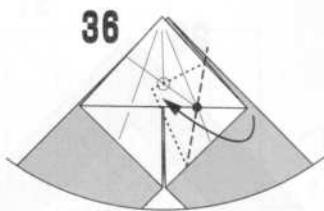

●を通り、かつ、折ったフチが
○を通るように折る

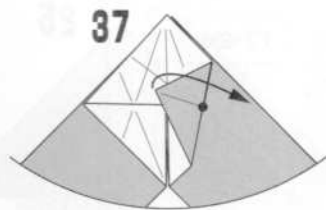

紙を戻す

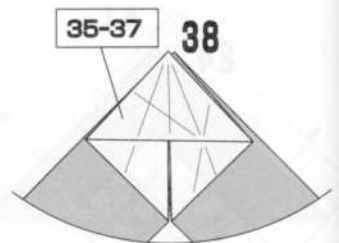

反対側も35~37と
同じように折る

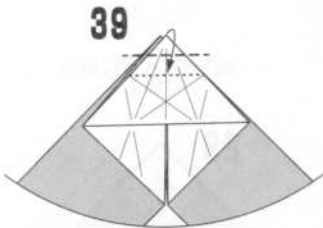

カドを折る

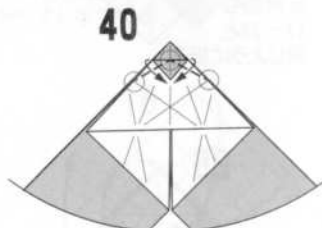

○と○をむすぶ線で折る

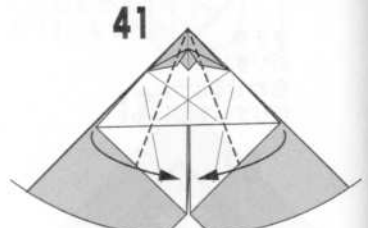

ついている折りすじを
使って折る

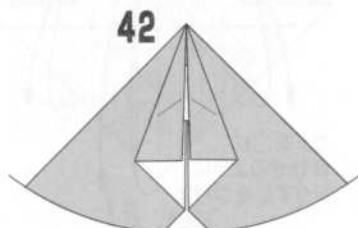

このようになる
(次の図は、上の紙を
はぶいた図となる)

透視(The inside view)

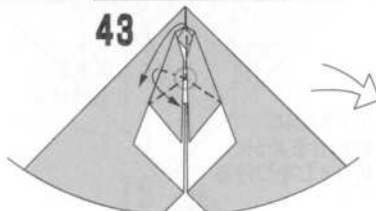

隠れている紙を、
ついている折りすじを使って
○を支点につまむように折り、
カドを紙の外に出す

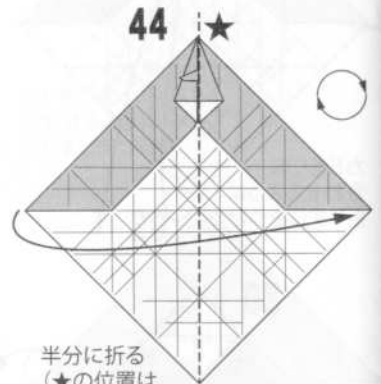

半分に折る
(★の位置は
次の図と一致する)

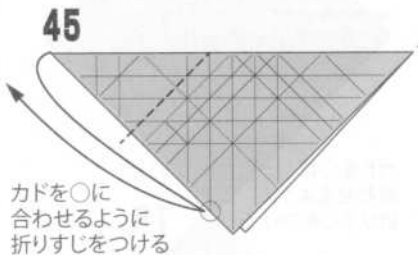

カドを○に
合わせるように
折りすじをつける

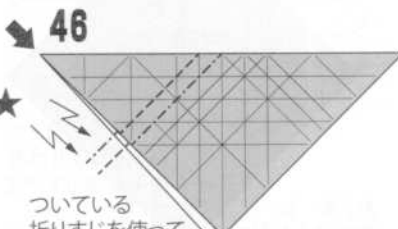

ついている
折りすじを使って
段折り中わり折りをおこなう

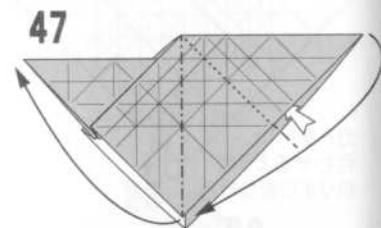

内側を開くように折る

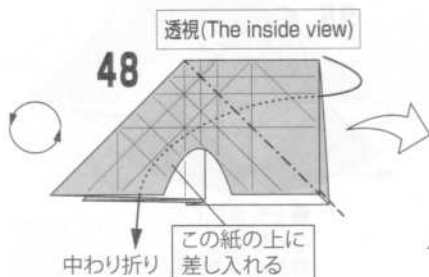

透視(The inside view)

この紙の上に
差し入れる
中わり折り

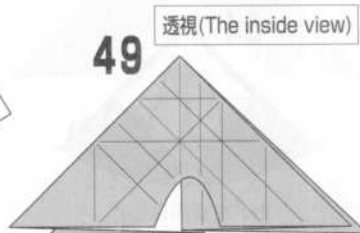

透視(The inside view)

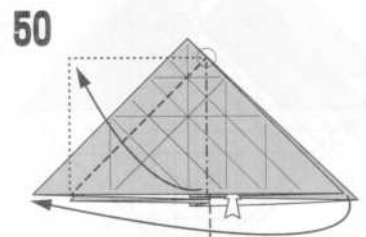

上の紙を開くように折る

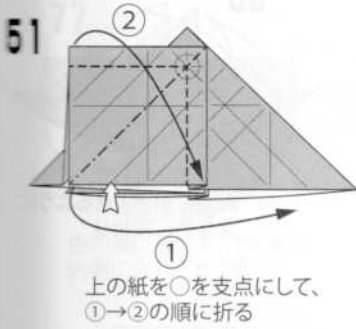

①
上の紙を○を支点にして、
①→②の順に折る



カドを反対側へ折る

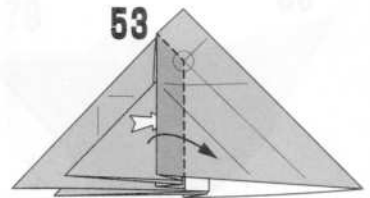

色の濃い部分を、
めくるように反対側へ折る
(平らにはならない)

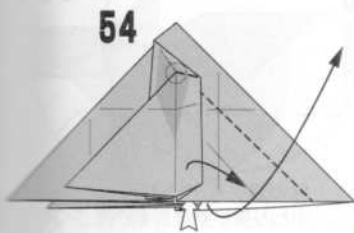

そのまま○を支点にして、
内側を開くように折る
(まだ、平らにならない)

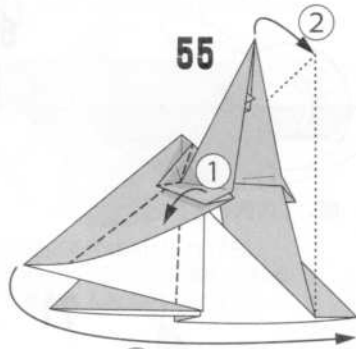

③
さらに、①→②→③の順で
折りたたむ

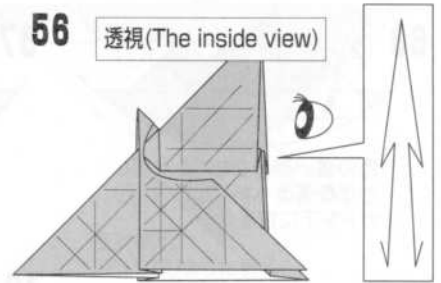

透視(The inside view)

このようになる
(横から見た断面図のよう
になっていることが重要)

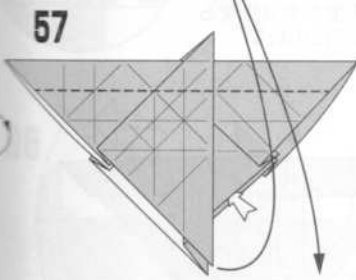

ついている折りすじを使って
あらためて折りすじをつける

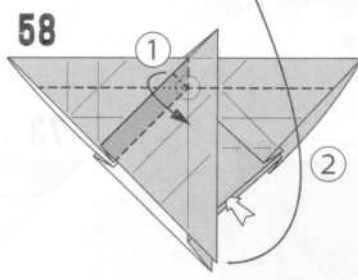

色の濃い部分を、反対側へ
めくるように折りながら①、
内側を開いて折る②)

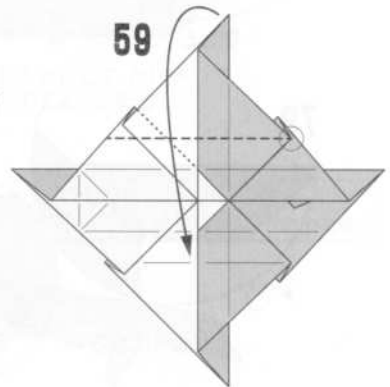

ついている折りすじを
延長して折る

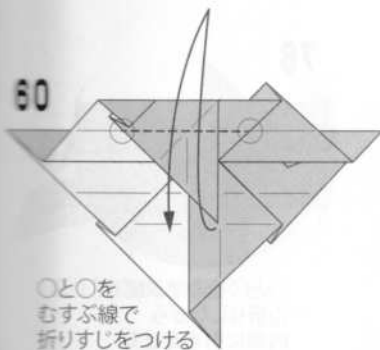

○と○を
むすぶ線で
折りすじをつける

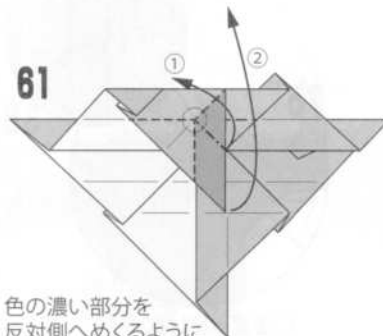

色の濃い部分を
反対側へめくるように
折りながら①、カドを上
に折る②)

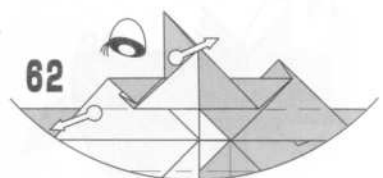

62

つまんで広げて、上から見る
(Pinch and spread,
and look from above)

63

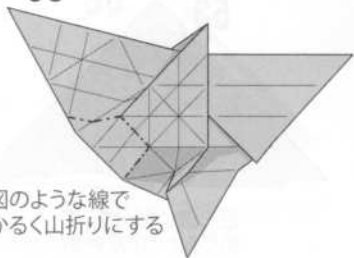

図のような線で
かるく山折りにする

64

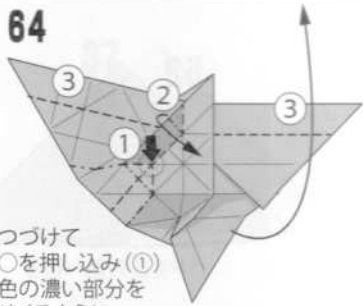

つづけて
○を押し込み(①)
色の濃い部分を
めくるように
反対側へ折りながら(②)、
カドを上へ折る

65

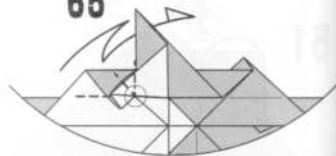

○を支点にして、
内側に引きよせるように
ななめに段折り

66

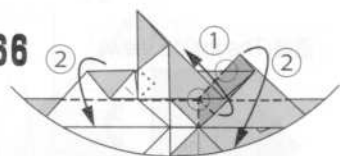

色の濃い部分をめくるように
左ななめ上へ折りながら(①)、
カドを下へ折る(②)

67

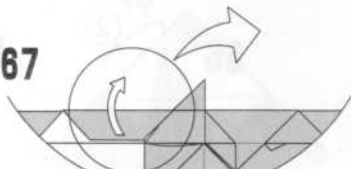

開いて内側を見る

透視(The inside view)

68

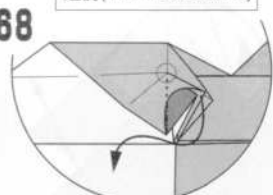

色の濃い部分のみ、
中わり折りで反対側へ

69

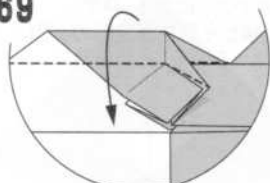

閉じる

70

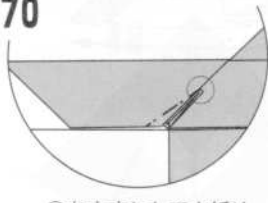

○を支点にして山折り
(ぐらい折り)

71

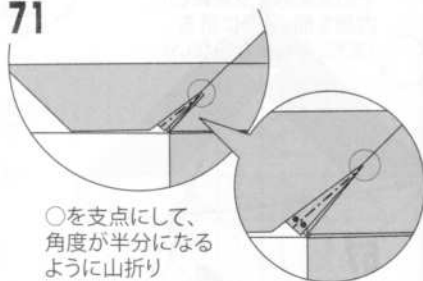

○を支点にして、
角度が半分になる
ように山折り

72

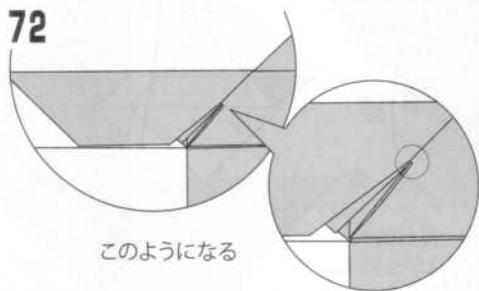

このようになる

73

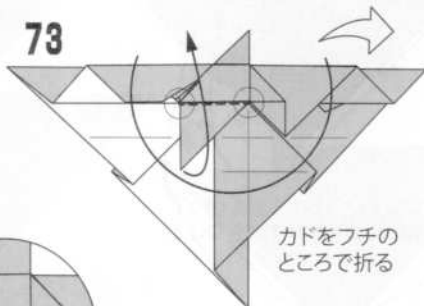

カドをフチの
ところで折る

74

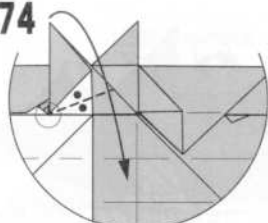

○を支点にして、
角度が半分にな
るように折る

75

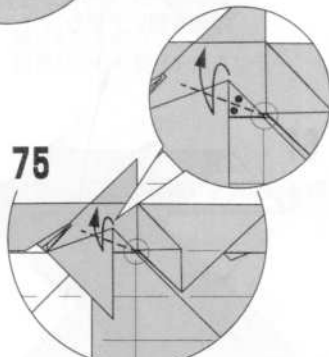

○を支点にして、
角度が半分になるように
折りすじをつける

76

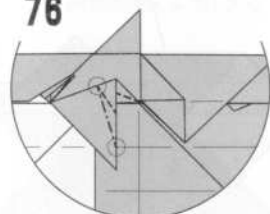

○と○をむすぶ線
で山折りしながら
内側に引き寄せる
ように折る

77

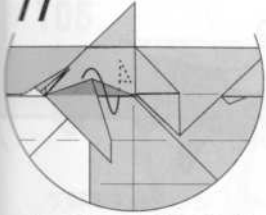

色の濃い部分を、下の紙の内側に入れてかくす

78

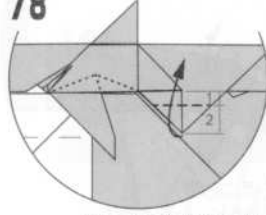

図のような位置で折る

79

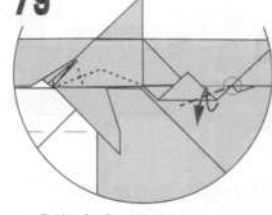

○を支点にして、角度が半分になるように折りすじをつける

80

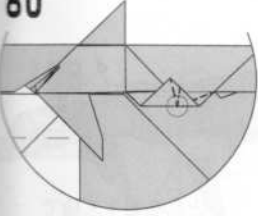

ついた折りすじを使って引き寄せるように折る

81

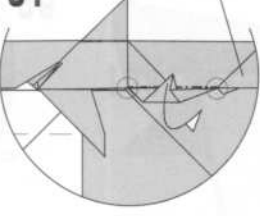

フチのところを山折りしながら、図で示しているところに差し入れる (すぐ後ろに入れるのではない)

この紙の内側に差し入れる (insert it inside this paper)

82

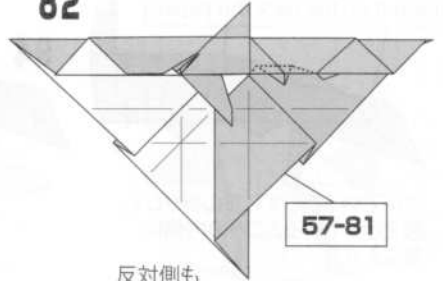

反対側も 57~81のように折る

57-81

83

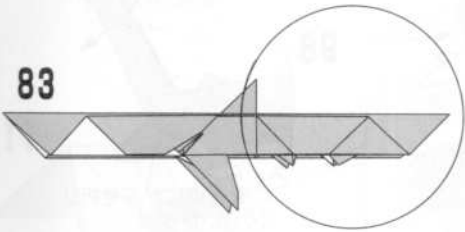

84

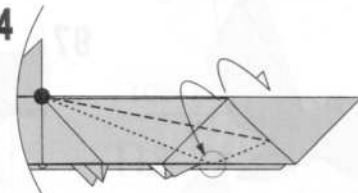

●を支点にして、カドが○にのるように折る

85

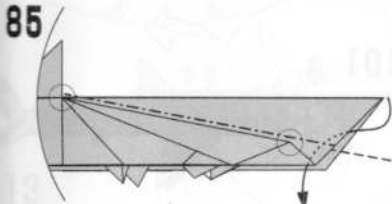

フチのところでもわり折り

86

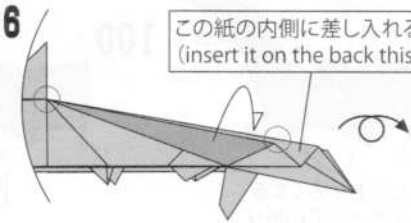

この紙の内側に差し入れる (insert it on the back this paper)

色の濃い部分を 図で示しているところに差し入れる

87

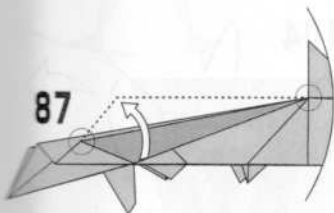

紙を開く (86とは違う)

88

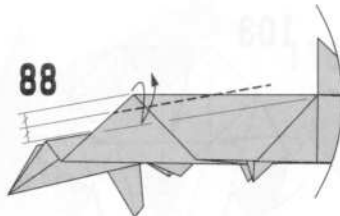

図のような線で折りすじをつける

89

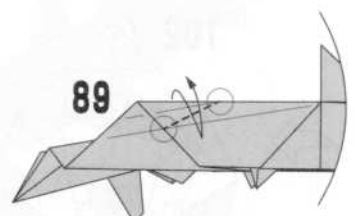

○と○をむすぶ線で、上の紙のみに折りすじをつける

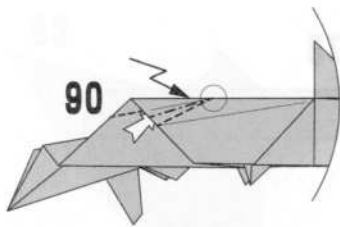

90

○を支点にして、ななめに引き寄せるように折る

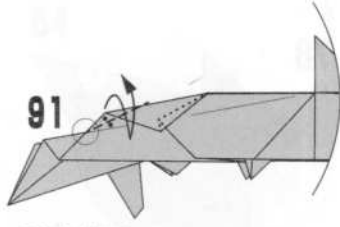

91

○を支点にして角度が半分になるように折りすじをつける

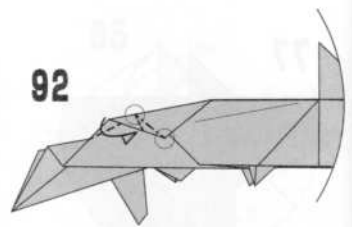

92

○と○をむすぶ線で山折りしながら内側に引き寄せるように折る

93

この紙の内側に差し入れる
(insert it on the back this paper)

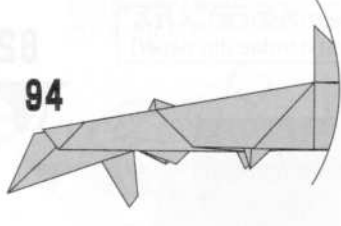
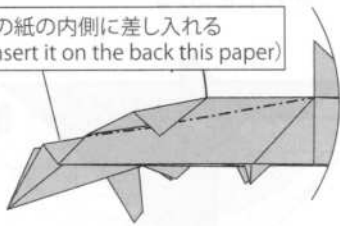

94

ついている折りすじを山折りして、図で示しているところの内側に差し入れる

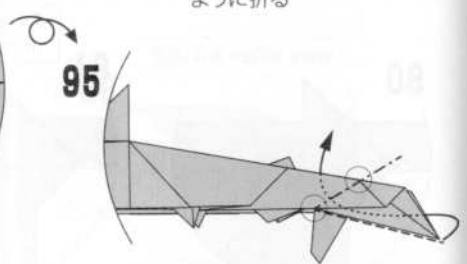

95

○と○をむすぶ線で中わり折り

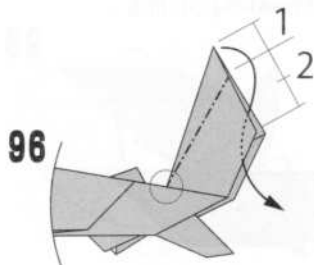

96

○を支点にして図のような線で中わり折り



97

○と○をむすぶ線ですぐ後ろに山折り(反対側も同じ)

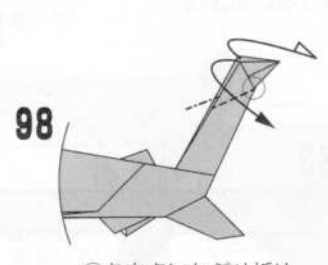

98

○を支点にかぶせ折り(ぐらい折り)

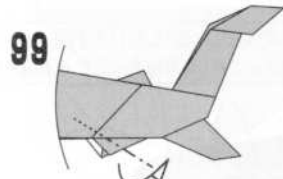

99

ヒレを小さくするイメージで山折り(ぐらい折り)

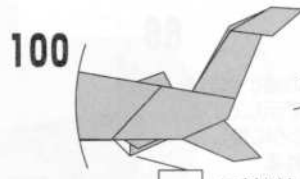

100

99 反対側も同じ

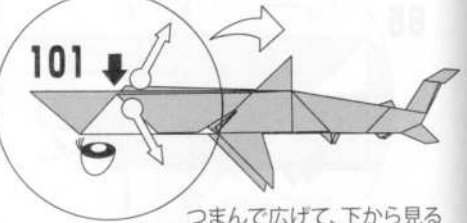

101

つまんで広げて、下から見る
(Pinch and spread,
and look from bottom)

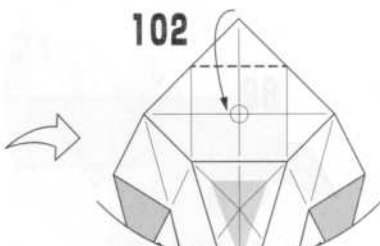

102

カドを○に合わせるように折る

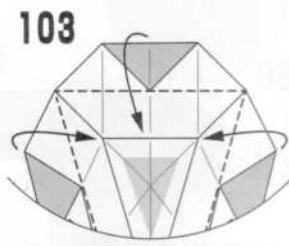

103

ついている折りすじで折る(まだ立体的のまま)

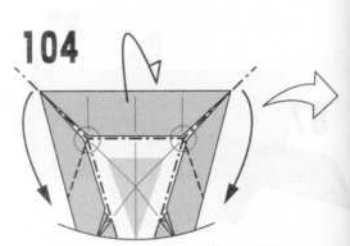

104

ついている折りすじを使って折る(まだ立体的のまま)

105

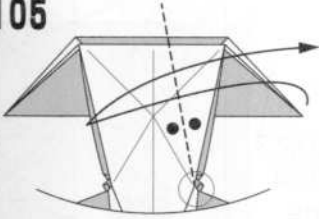

○を支点にして、
角度が半分にな
るように
折りすじをつける

106

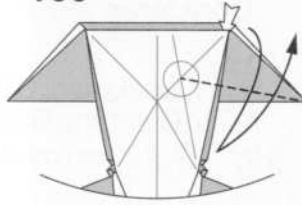

白矢印より上の部分を、
○とカドをむすぶ線で
折りすじをつける

107

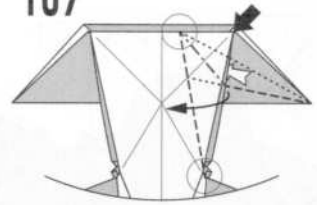

ついた折りすじを使って
引き寄せるように折りながら、
黒矢印の部分をつぶす

108

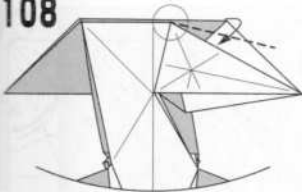

○を支点にして、
角度が半分にな
るように折る

109

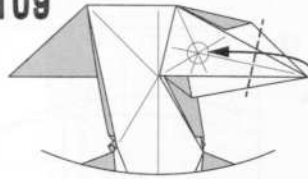

カドが○に合う
ように折る

110

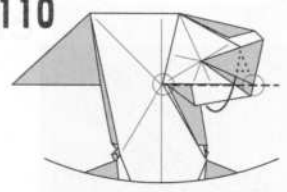

○と○をむすぶ線で折って、
右のカドをポケット状の
ところに入れる

111

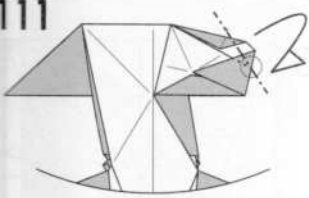

○を支点にして、山折りのぐらい折り
(目になる部分なので、表側を
確認しながら折るとよい)

表側(Front side view)

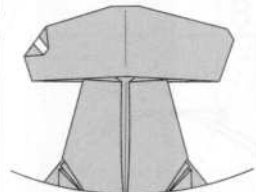

105-111

112

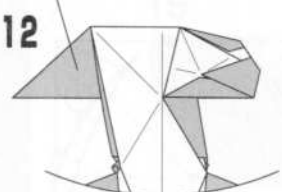

反対側も105~111と
同じように折る

113

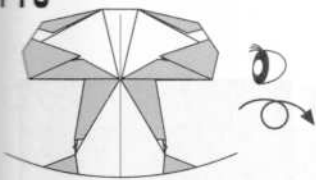

114

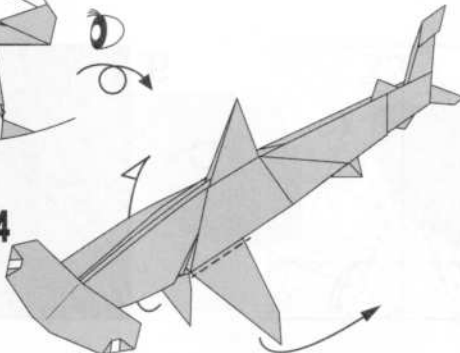

フチのところで折って
約90°くらい起こす

115

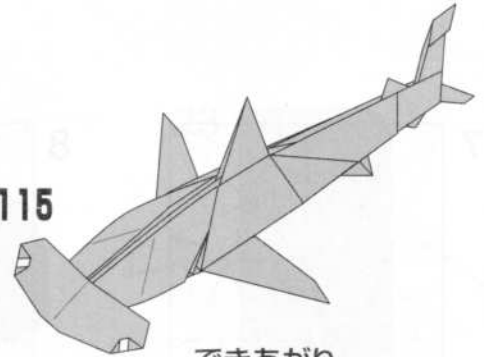

できあがり

鼠鱼

Corydoras

设计 / Designed: 08/2023
图示 / Diagram: 03/2024
by 张原恺 Yuankai Zhang

推荐用纸 / paper :
-30 x 30 cm

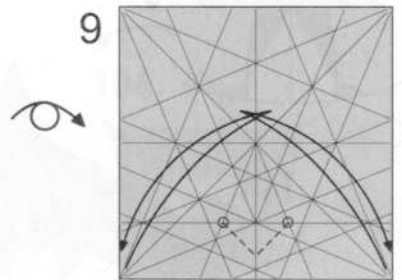
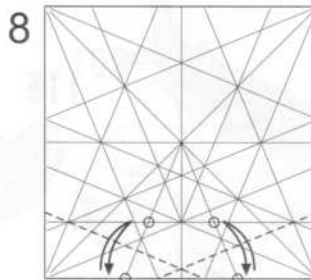
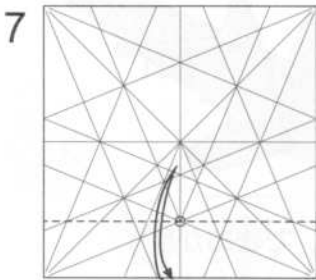
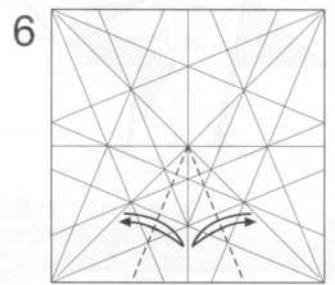
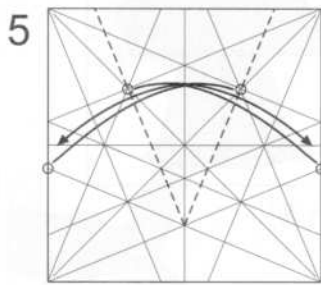
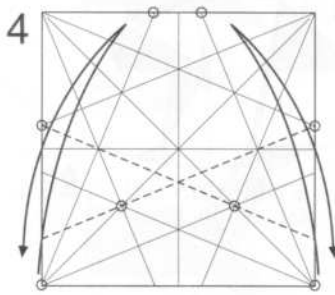
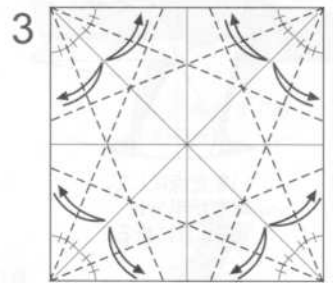
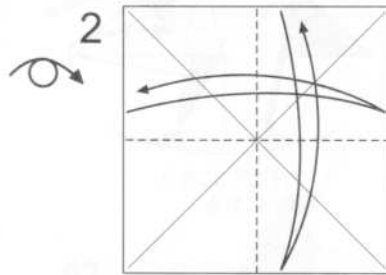
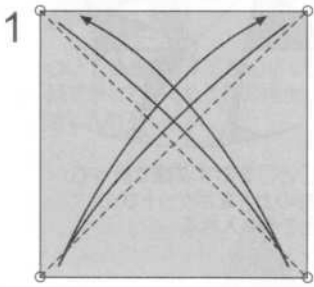
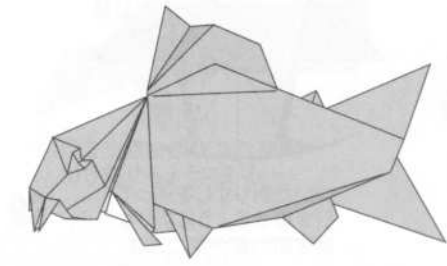
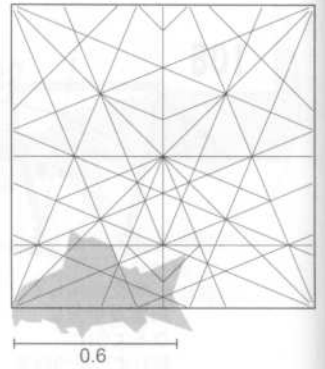

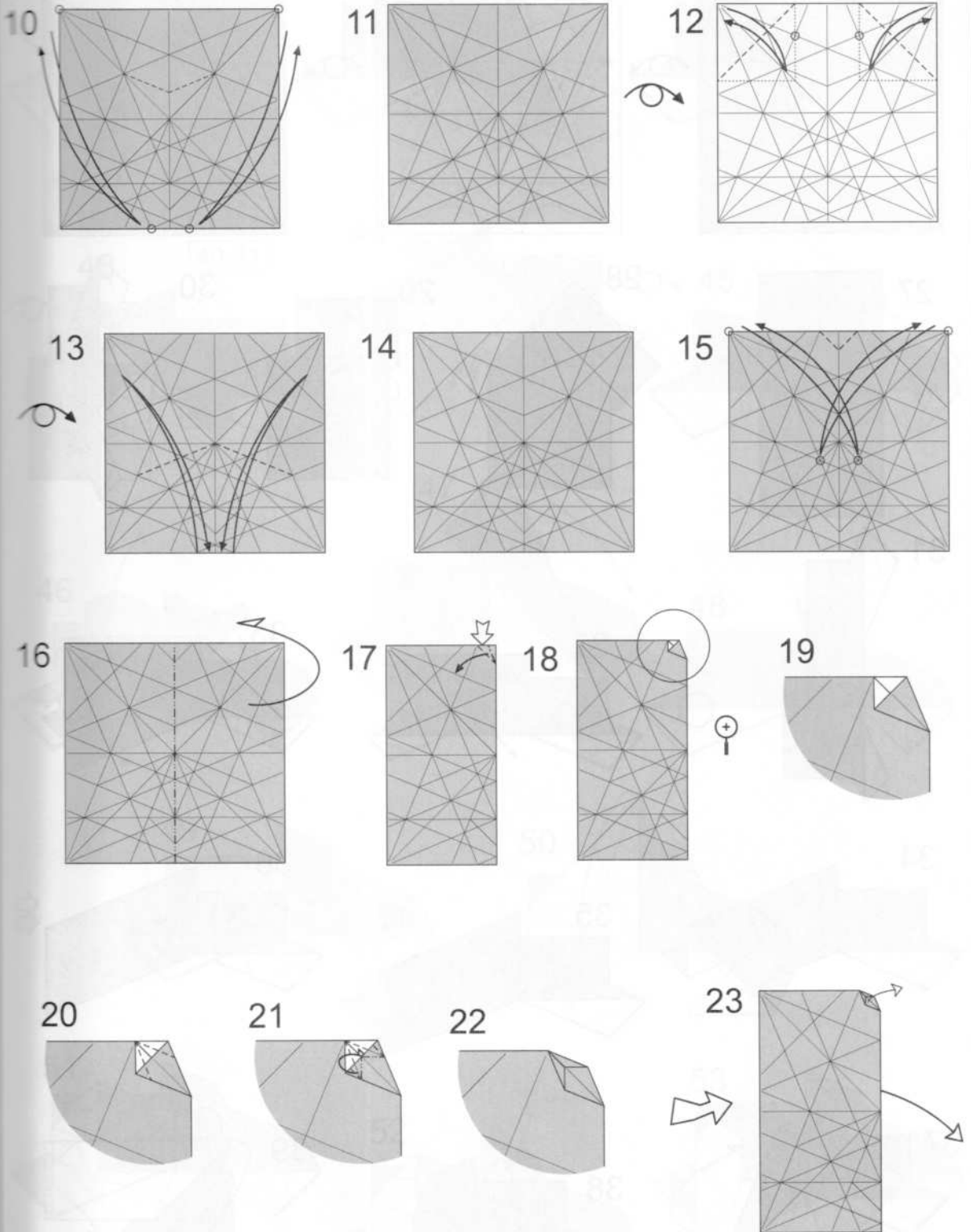

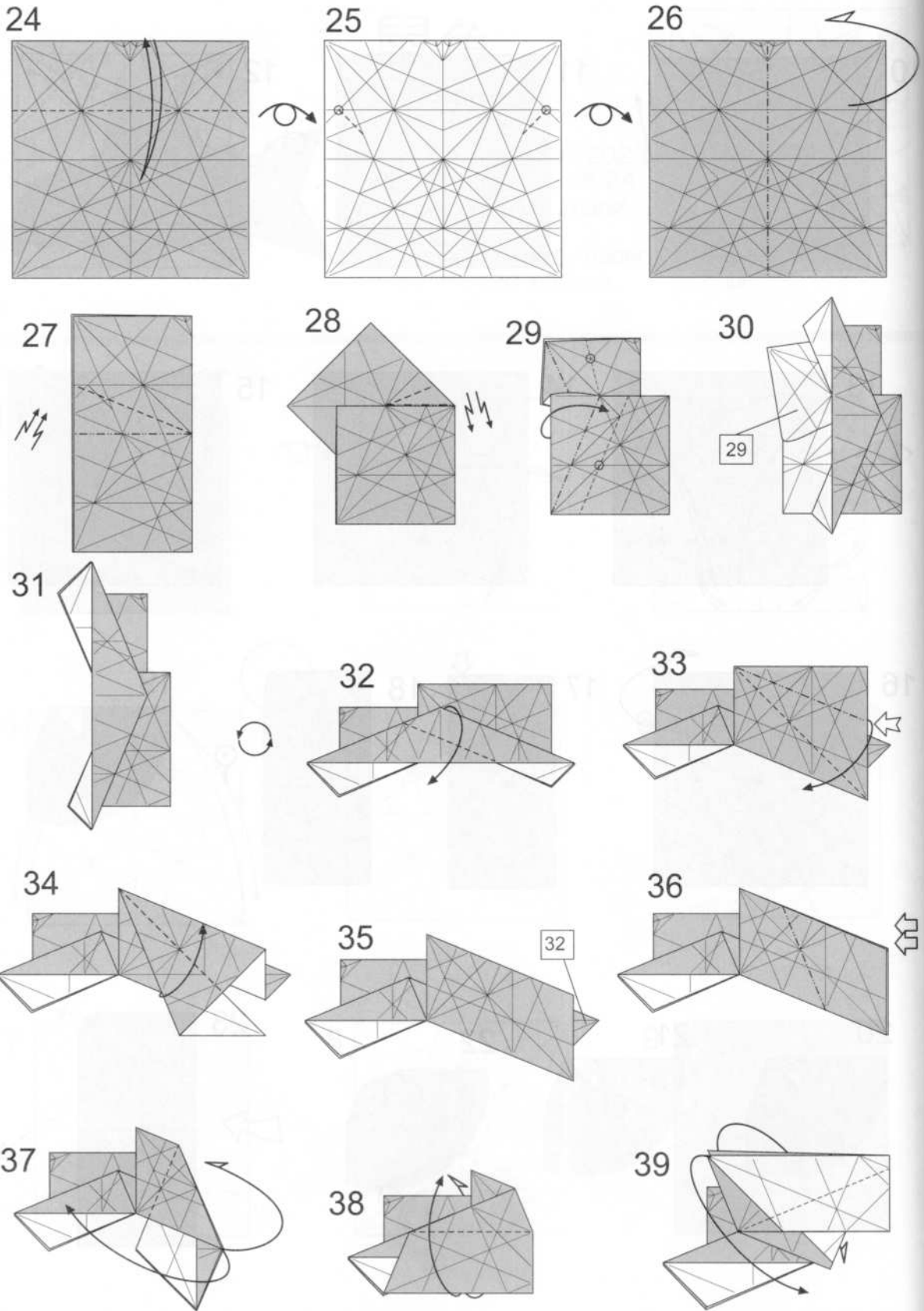

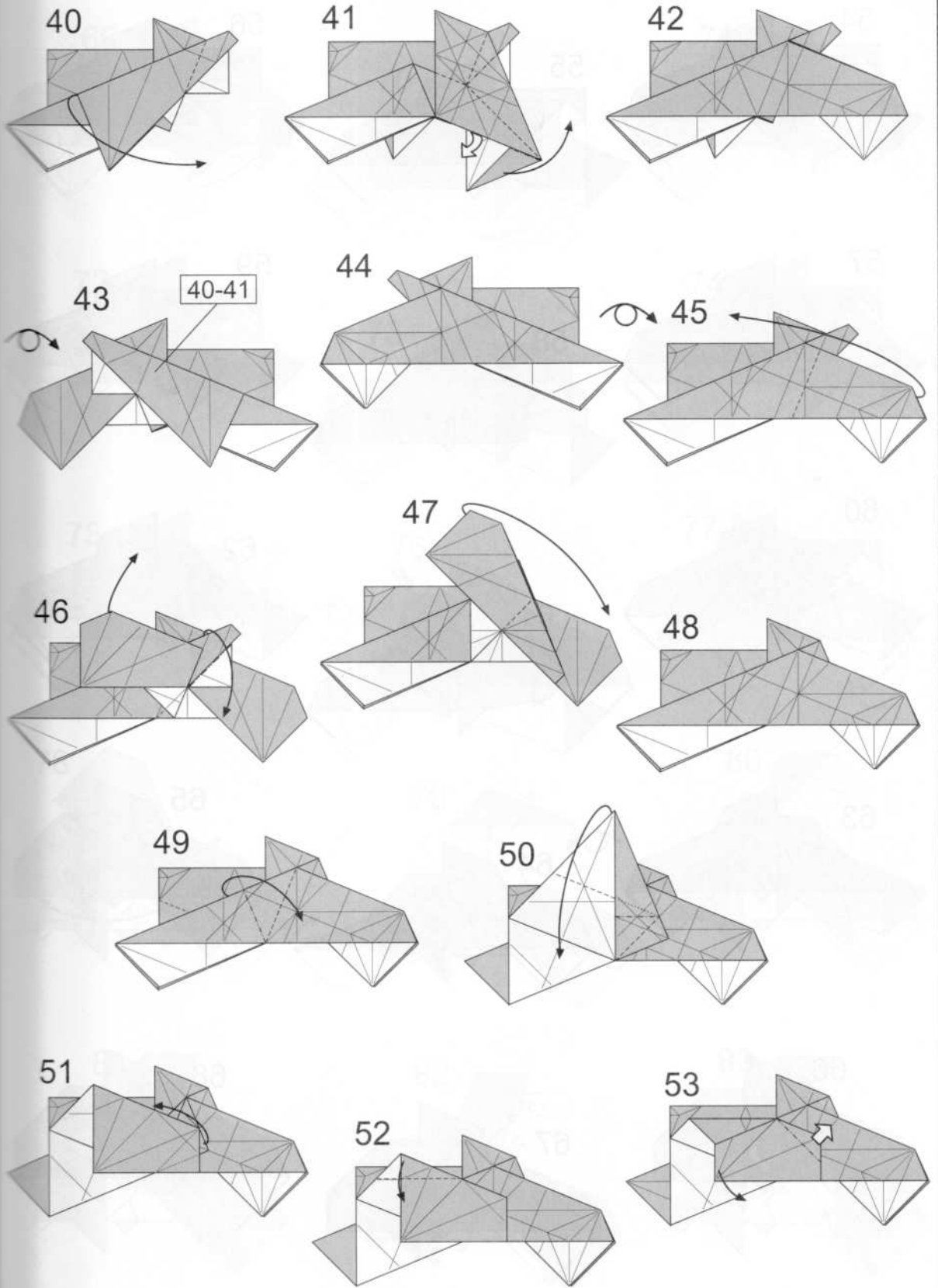

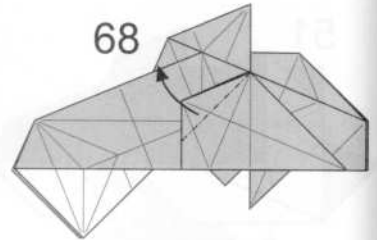
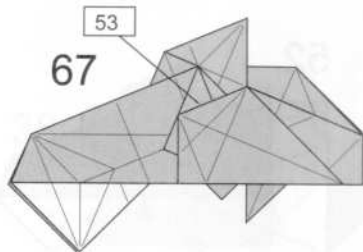
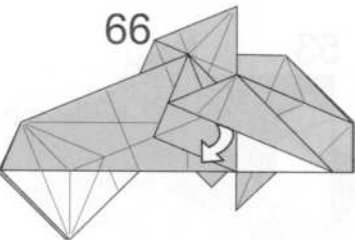
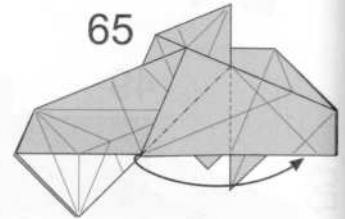
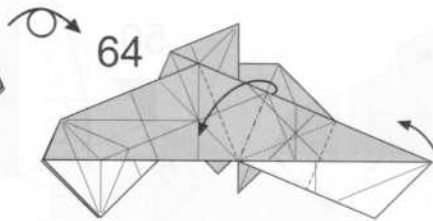
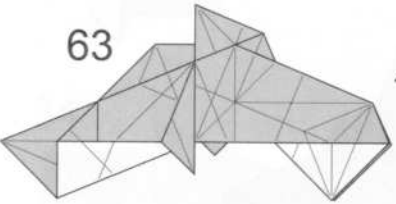
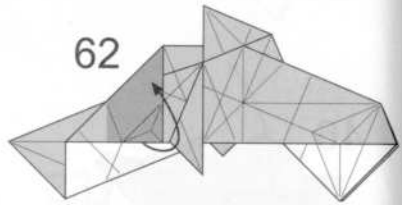
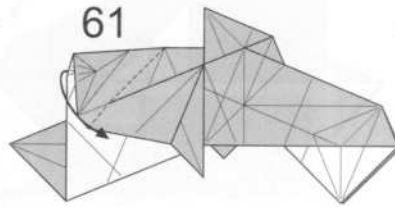
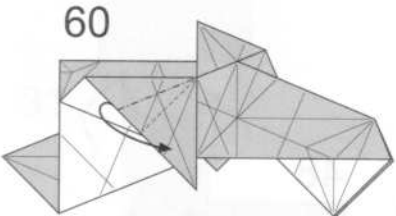
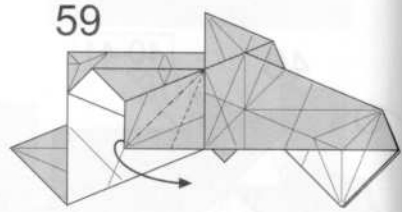
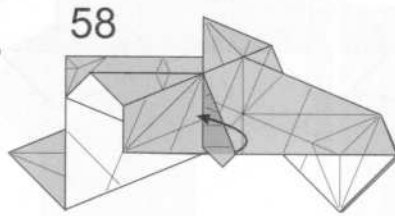
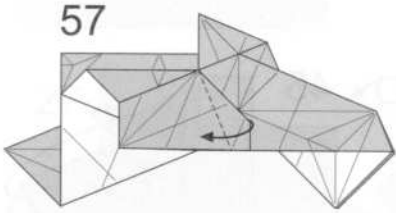
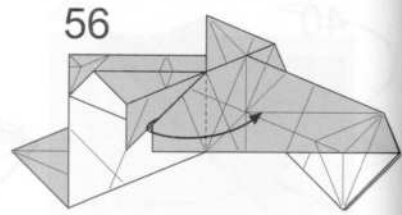
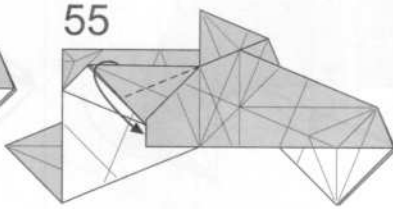
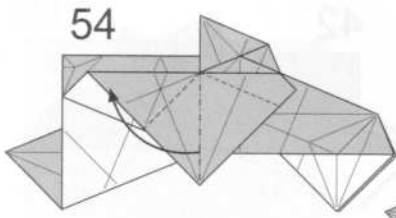

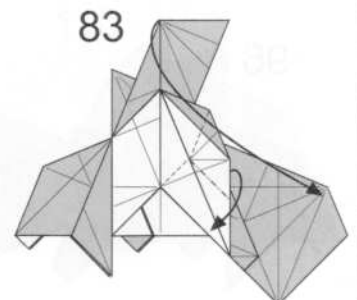
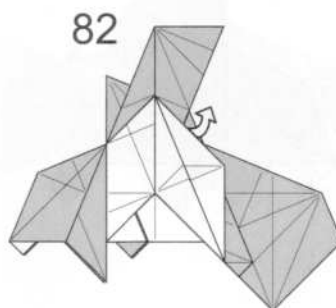
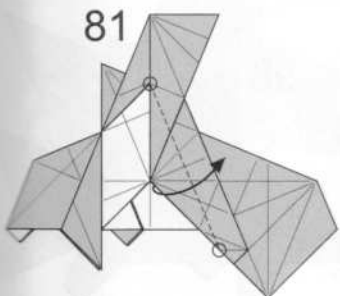
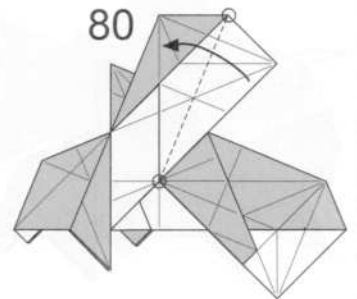
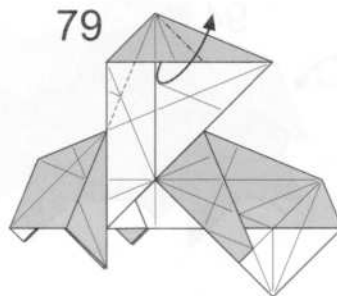
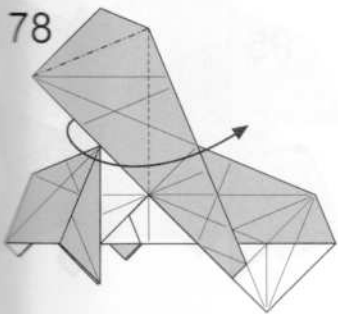
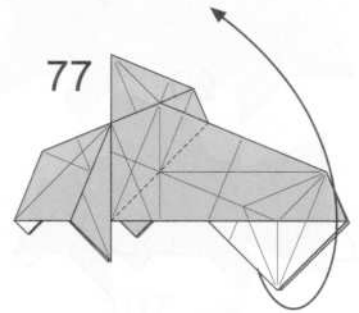
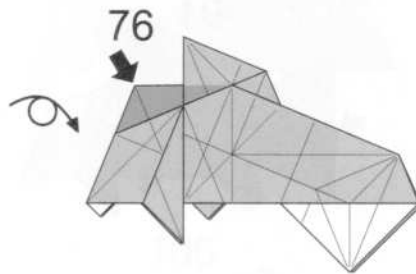
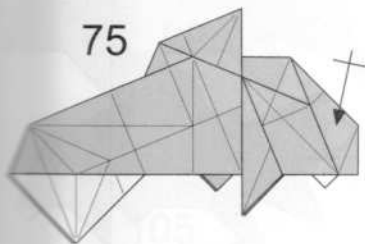
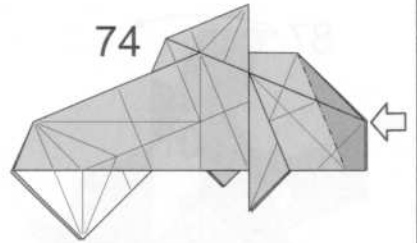
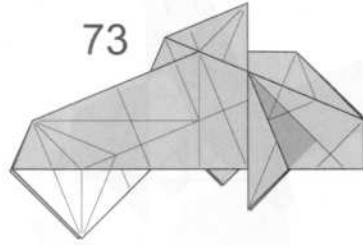
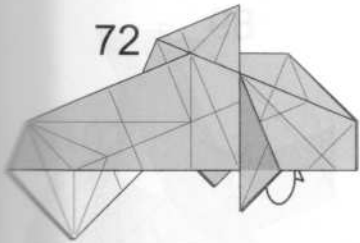
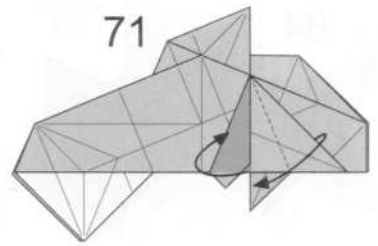
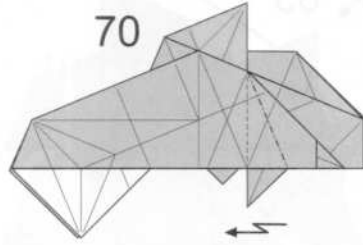
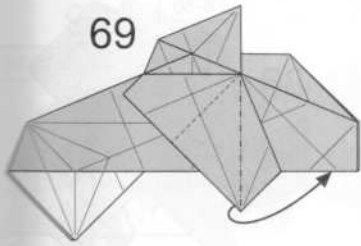

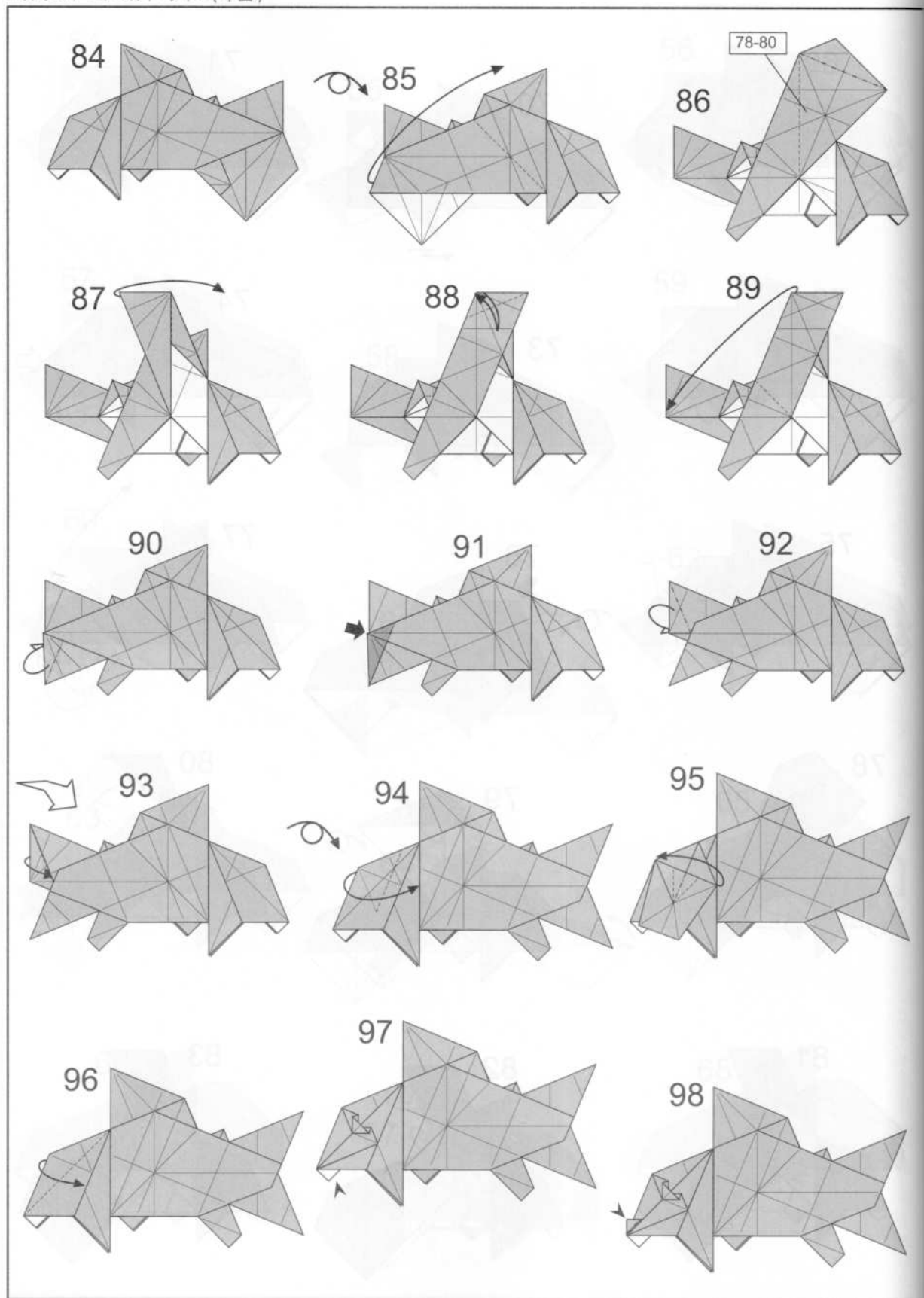

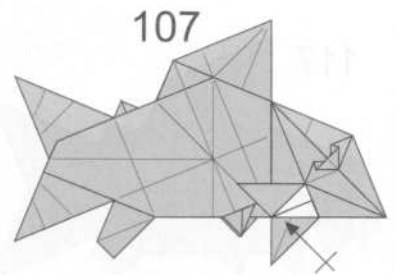
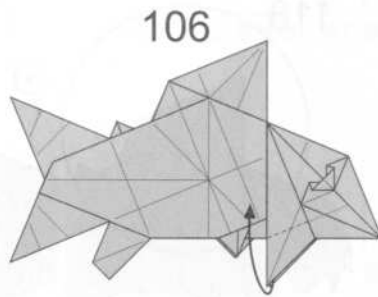
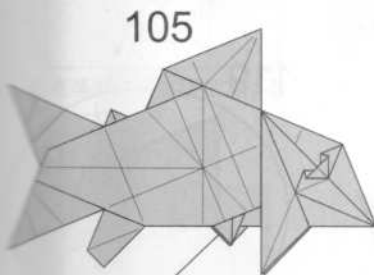
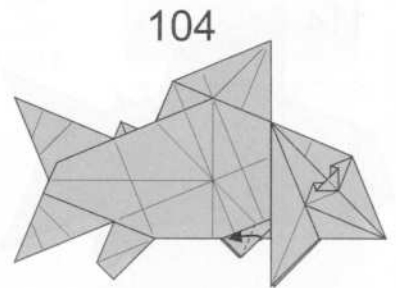
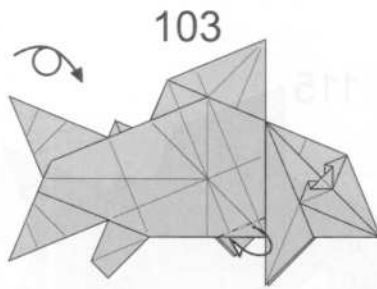
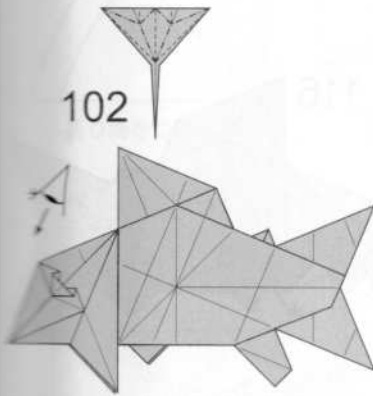
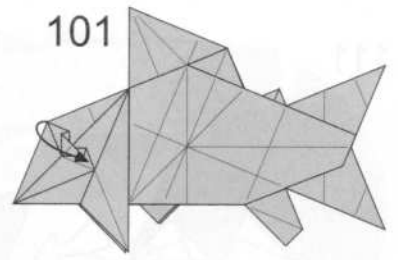
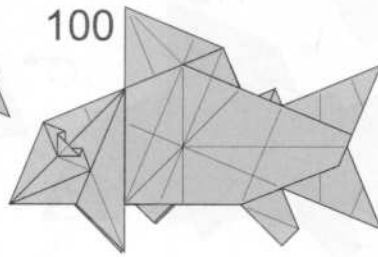
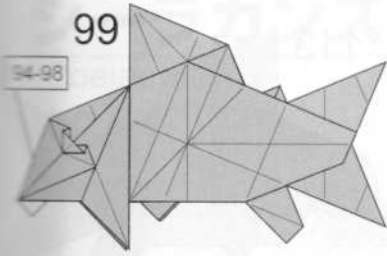

103-104

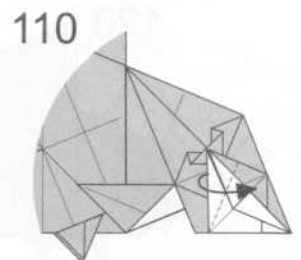
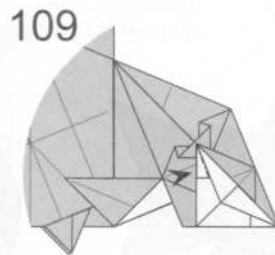
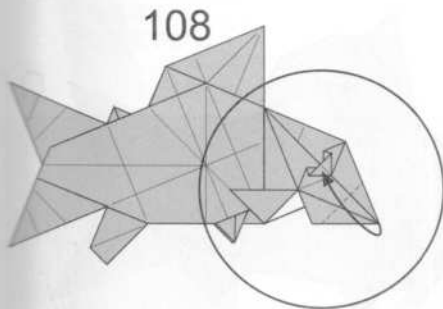

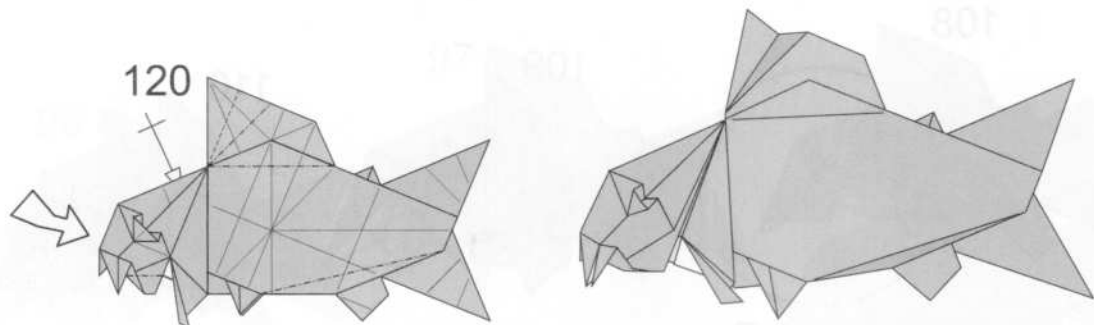
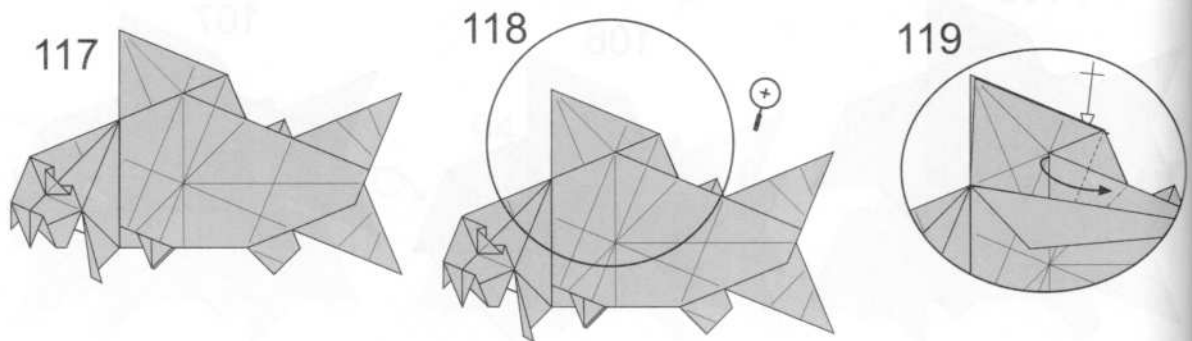
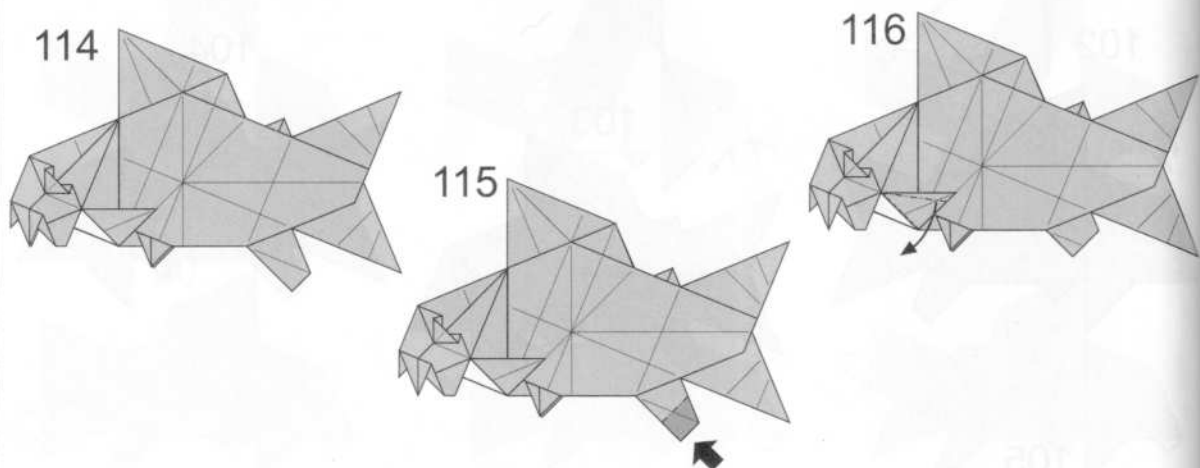
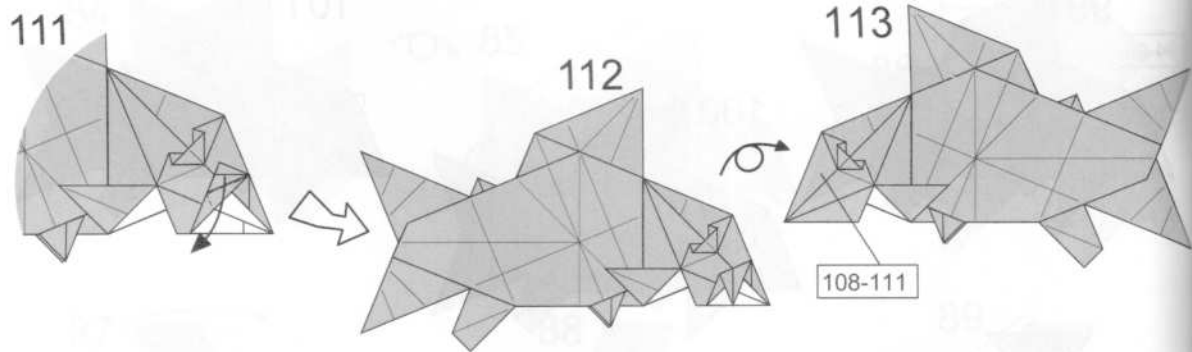

シーラカンス 各務 均

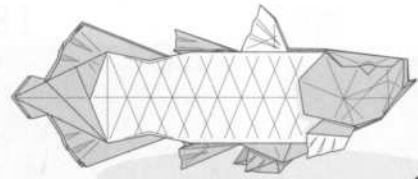

Coelacanth

Kakami Hitoshi

創作 2024年2月

作図 2024年5月

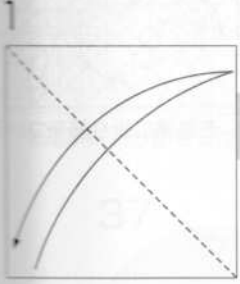

1 折り筋をつける

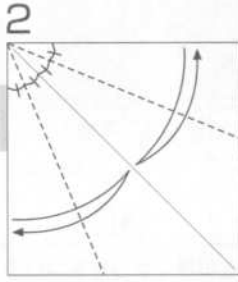

2 折り筋をつける

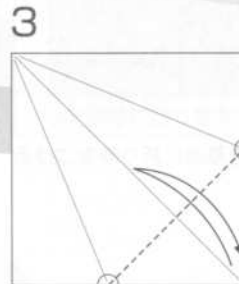

3 ○を基準に折り筋をつける

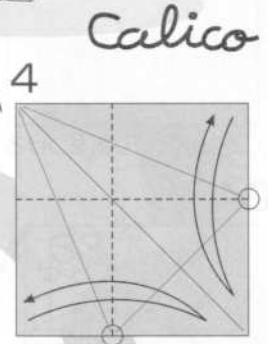

4 ○を基準に折り筋をつける

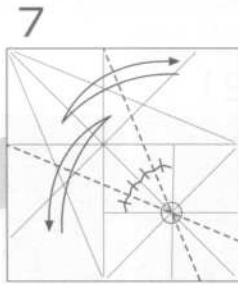

7 ○を基準に折り筋をつける

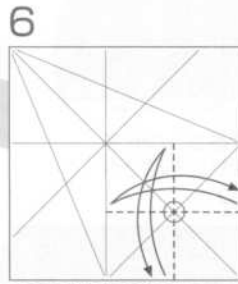

6 ○を基準に折り筋をつける

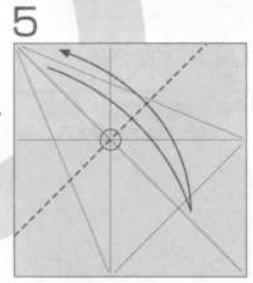

5 ○を基準に折り筋をつける

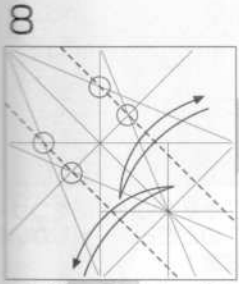

8 ○を基準に折り筋をつける

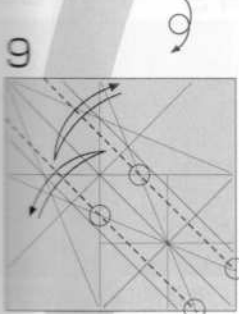

9 ○を基準に折り筋をつける

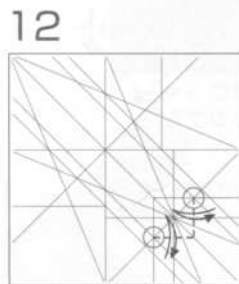

12 ○を基準に折り筋をつける

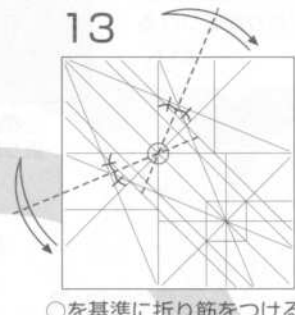

13 ○を基準に折り筋をつける

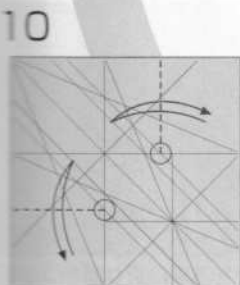

10 ○を基準に折り筋をつける



11 ○を基準に折り筋をつける

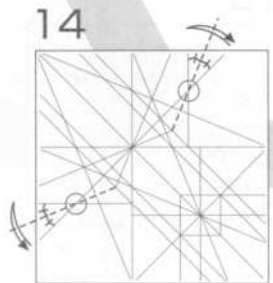

14 ○を基準に折り筋をつける

25

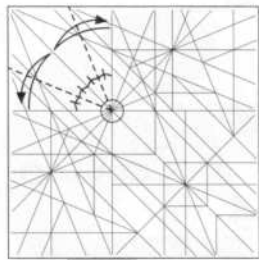

○を基準に折り筋をつける

26

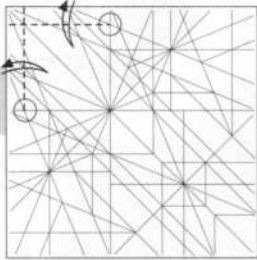

○を基準に折り筋をつける

27

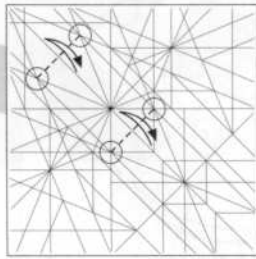

○を基準に折り筋をつける

28

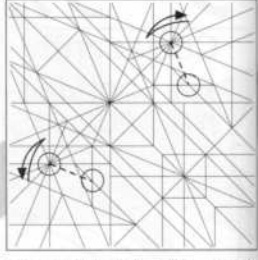

○を基準に折り筋をつける

24

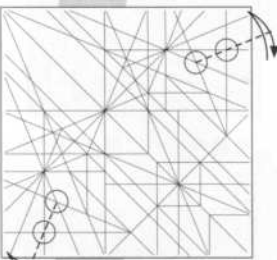

○を基準に折り筋をつける

23

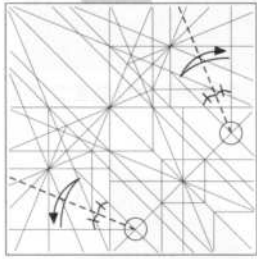

○を基準に折り筋をつける

22

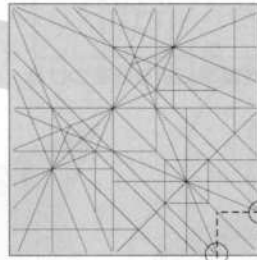

○を基準に折り筋をつける

21

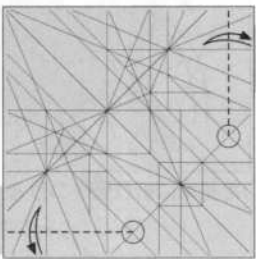

○を基準に折り筋をつける

20

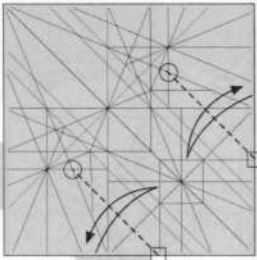

○を基準に折り筋をつける
□のところは一致しないので注意!

19

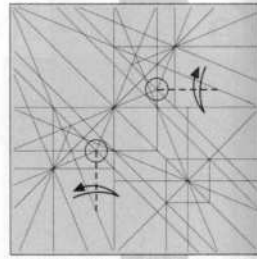

○を基準に折り筋をつける

15

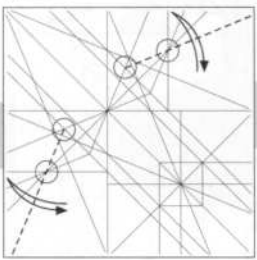

○を基準に折り筋をつける

16

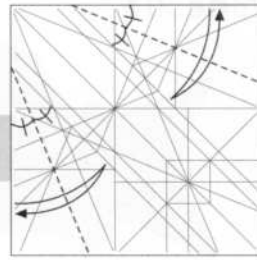

折り筋をつける

17

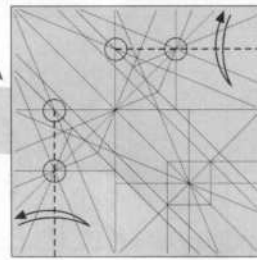

○を基準に折り筋をつける

18

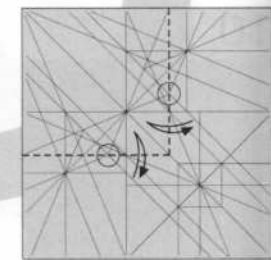

○を基準に折り筋をつける

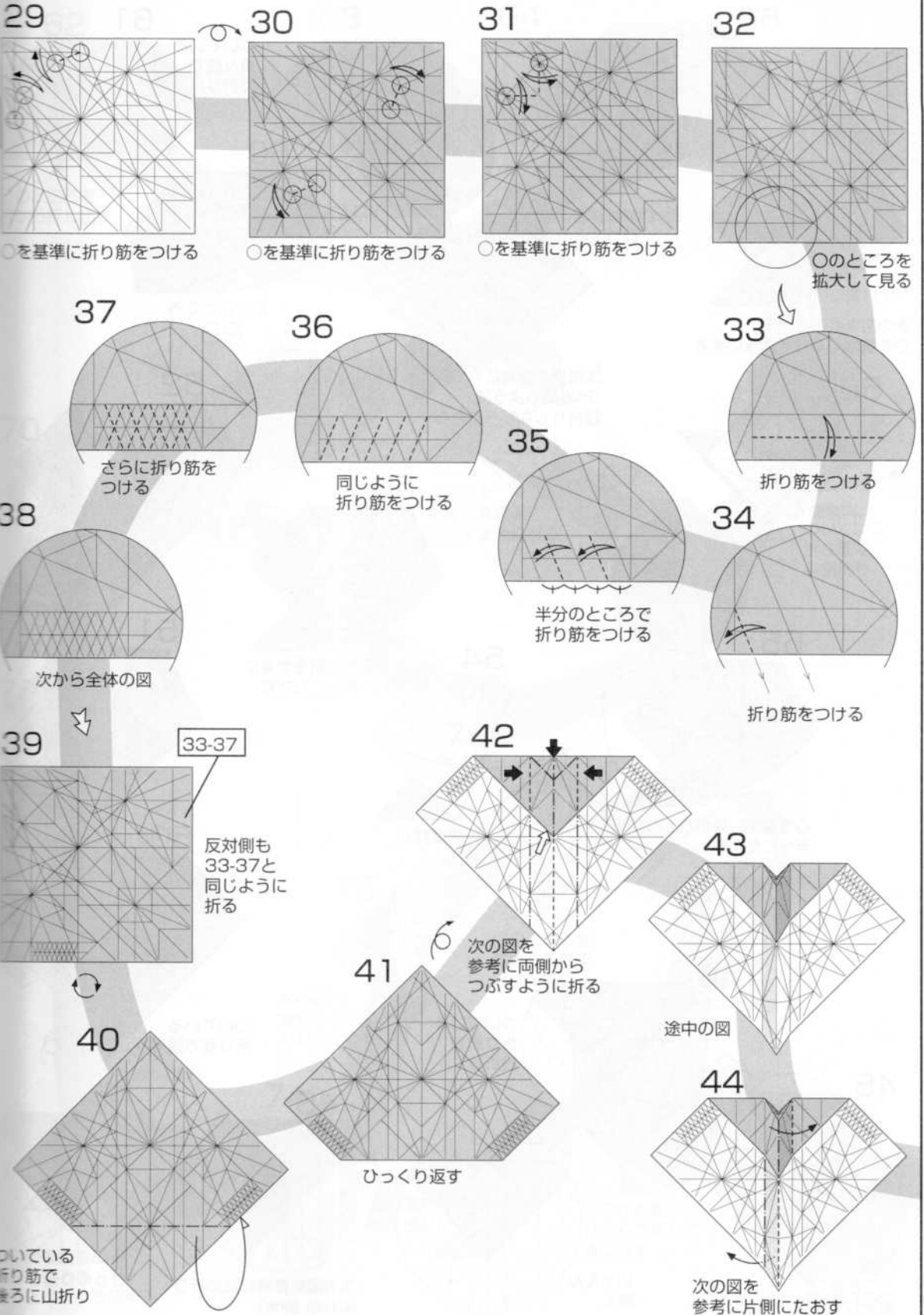

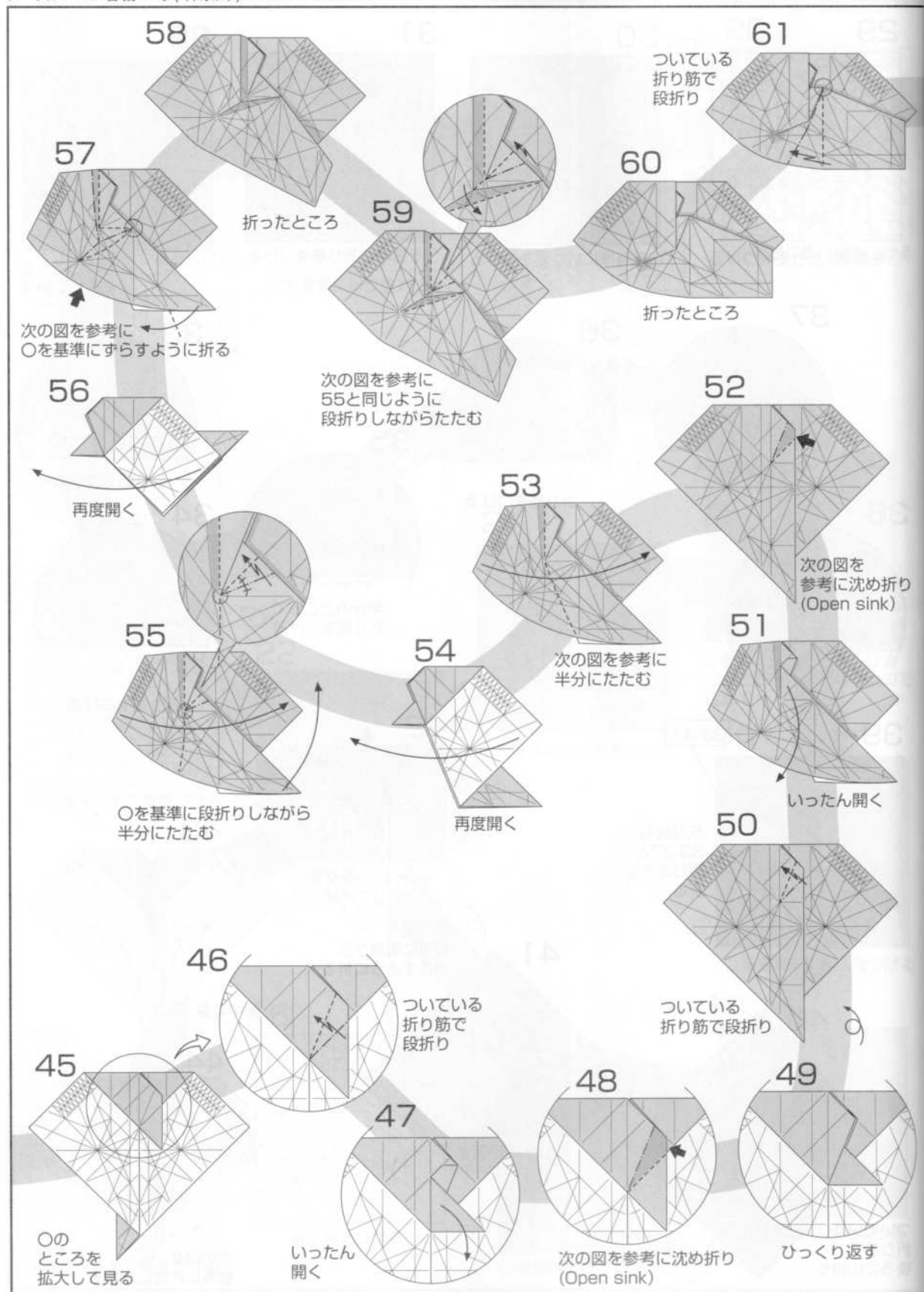

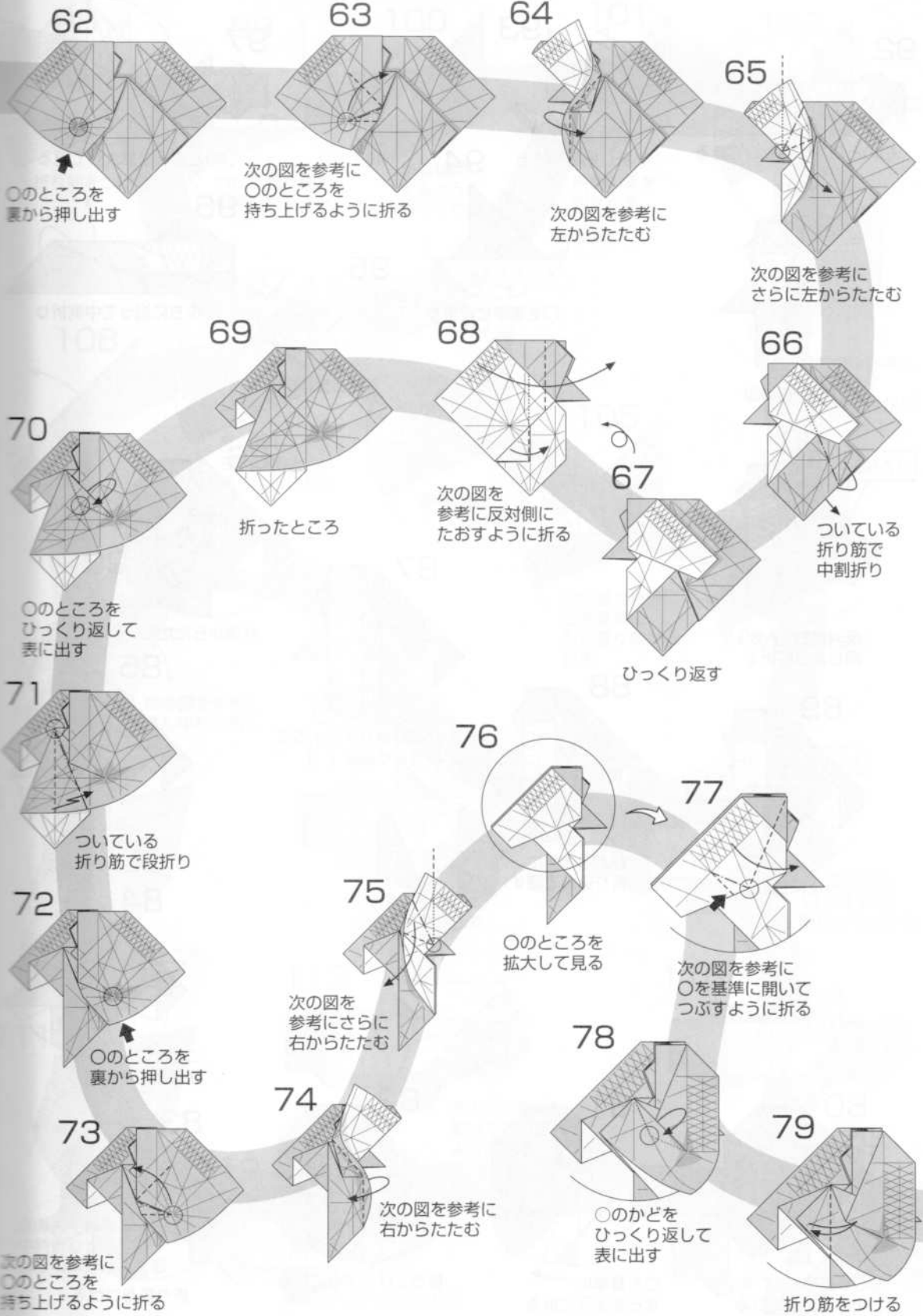

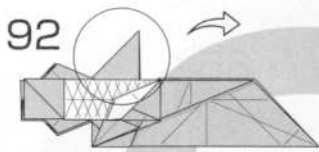

92 ○のところを拡大して見る

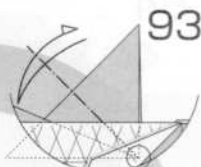

93 折り筋をつける

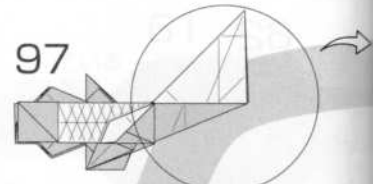

97 ○のところを拡大して見る



91 次から全体の図

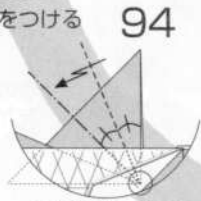

94 ○を基準に段折り

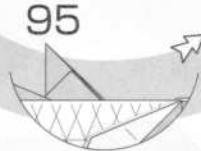

95 次から全体の図



96 ふちに沿って中割折り

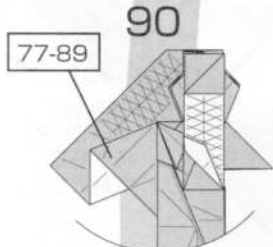

90 反対側も77-89と同じように折る

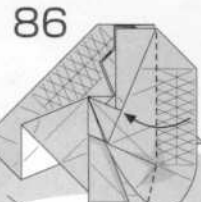

86 右側からたたむ

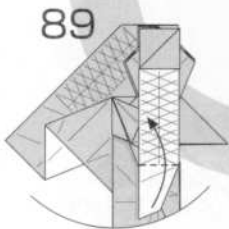

89 上に谷折り

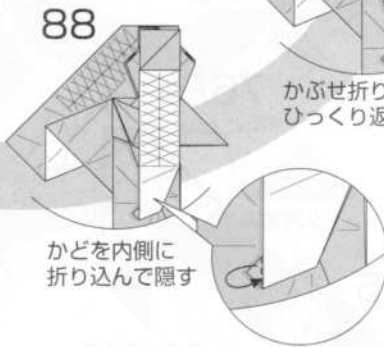

88 かどを内側に折り込んで隠す

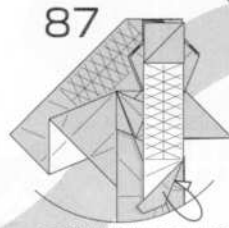

87 かぶせ折りするようにひっくり返す

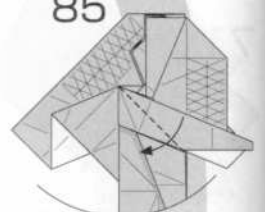

85 82で折ったところを戻す

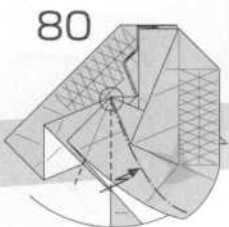

80 ○を基準にずらすように折る

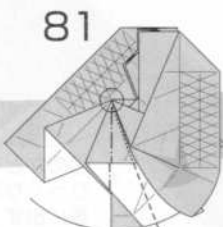

81 ○を基準にずらすように折る



82 持ち上げるように折る

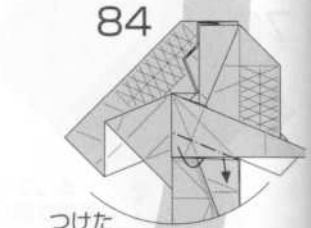

84 つけた折り筋で中割折り

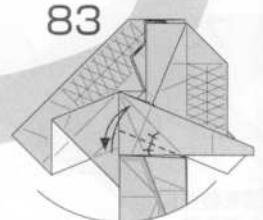

83 折り筋をつける

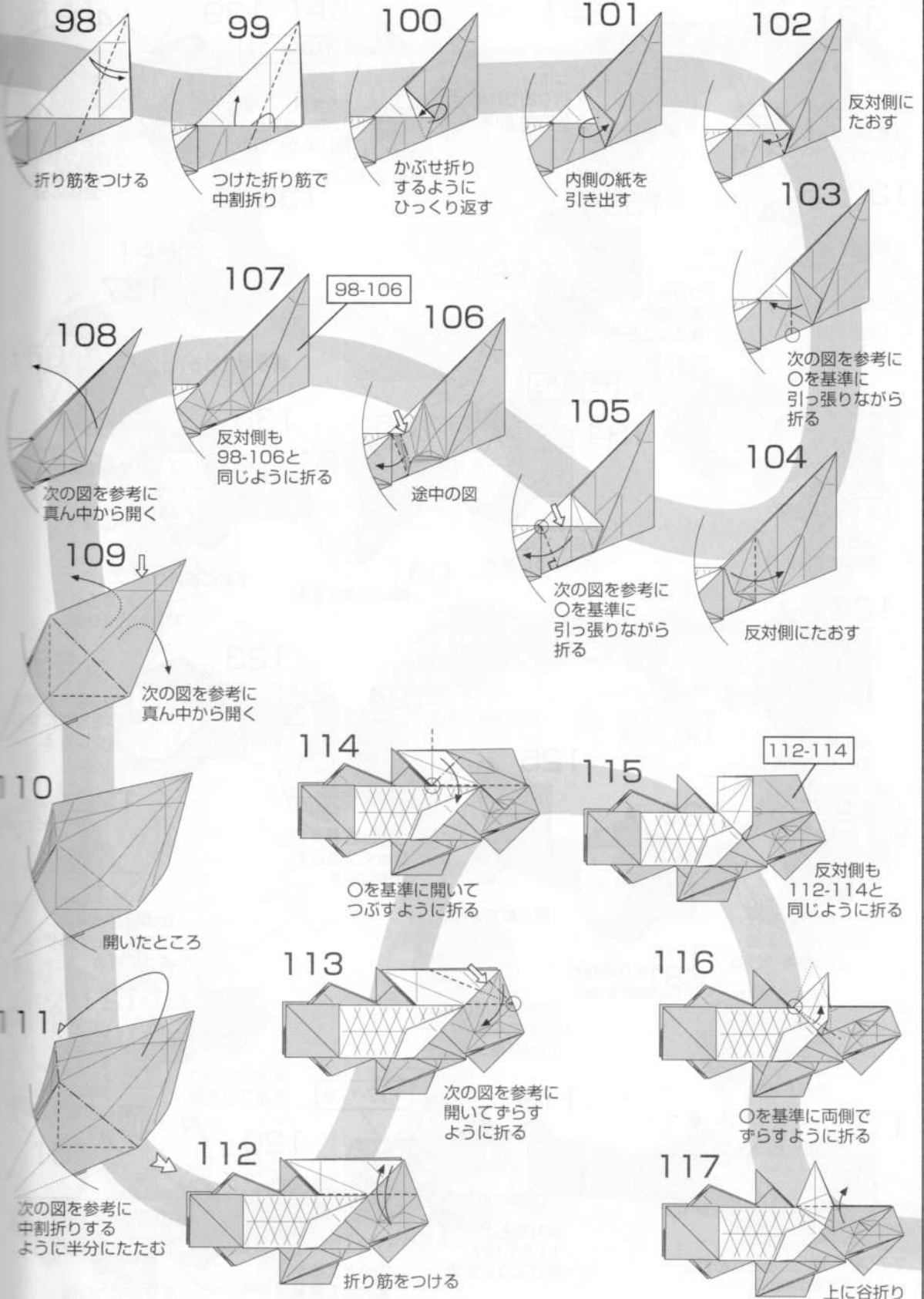

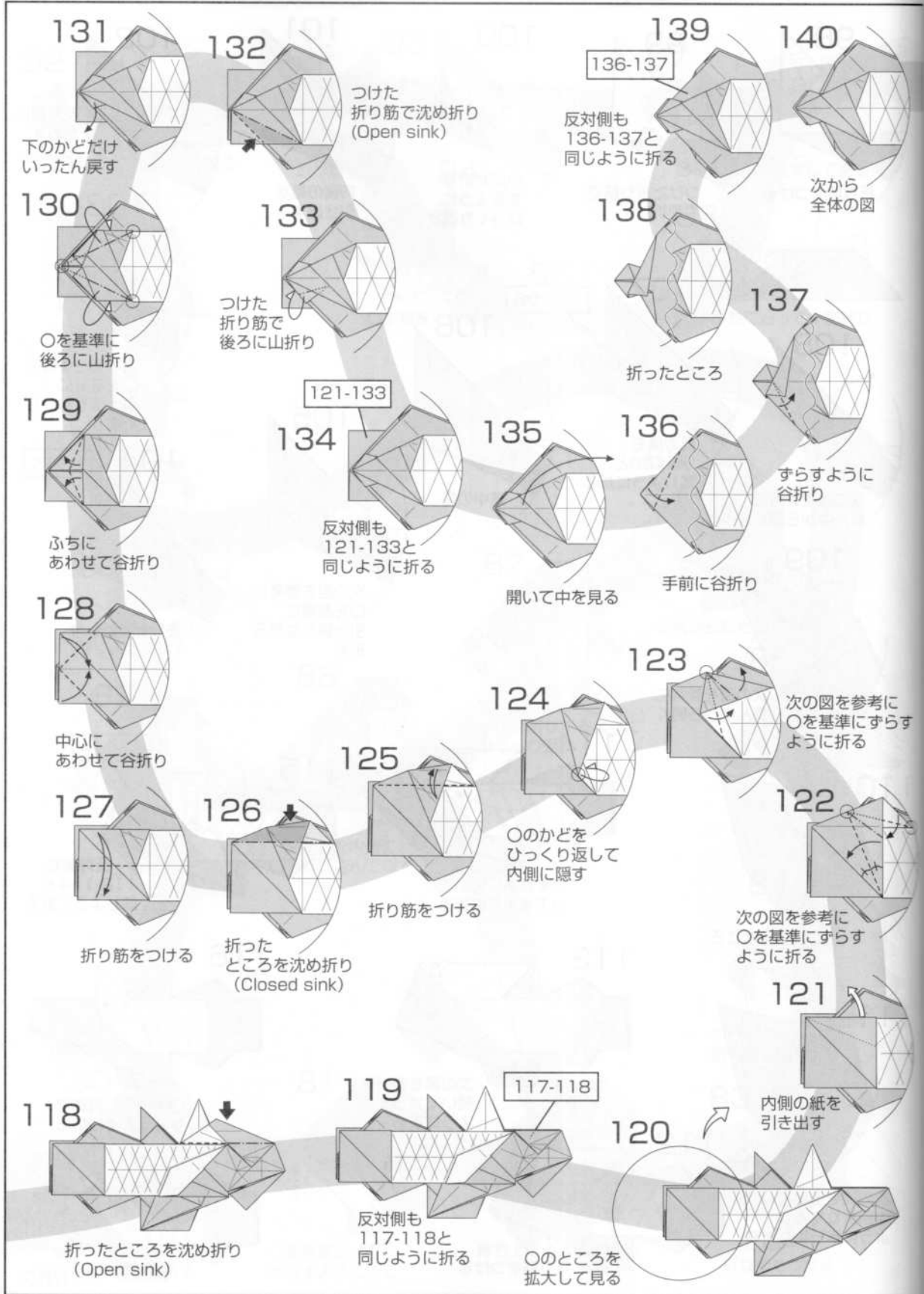

141 次の図を参考に Oを基準に段折り (反対側も同じ)

142 Oのところを拡大して見る

143 次の図を参考に Oを基準にすらすらように折り込む (反対側も同じ)

144 次の図を参考に かど全体を後ろにすらすら (反対側も同じ)

145 次から全体の図

146 Oのところを拡大して見る

147 Oを基準に 折り筋をつける

148 つけた折り筋で 中割折り

149 折り筋をつける

150 つけた折り筋で 中割折り

151 かどを 折り込んで隠す

152 手前に谷折り

153 次から全体の図

154 Oのところを 拡大して見る

155 開いて中を見る

156 中を見たところ

157 Oを基準に開いて つぶすように折る

158 次の図を参考に Oを基準にすらすらように折り込む

159 Oを基準に段折り

160 次から全体の図

161 Oのところを 拡大して見る

162 ふちに 沿って山折りして 後ろに折り込む

163 折り筋を つける

164 開いてつぶす ように折る

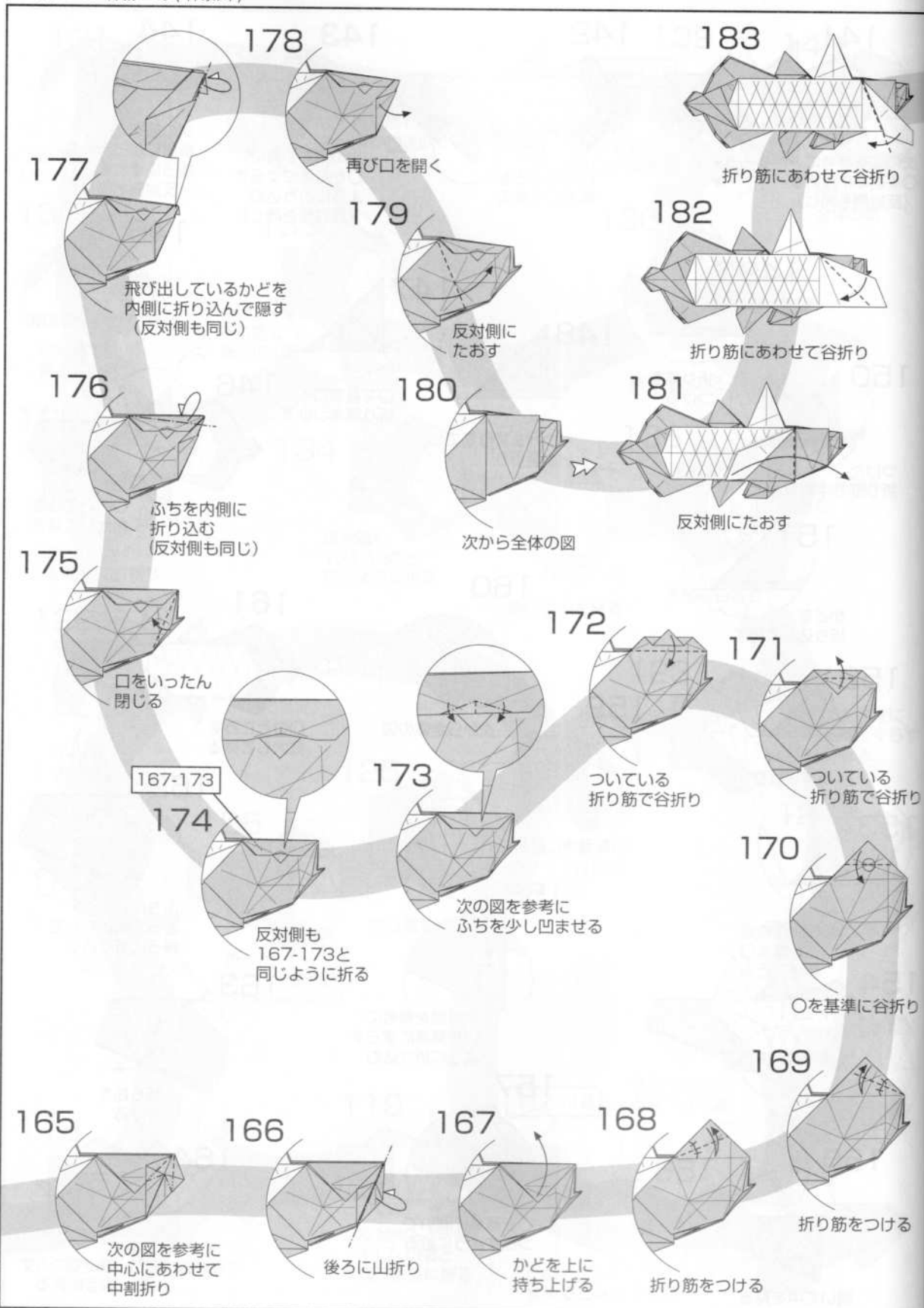

184

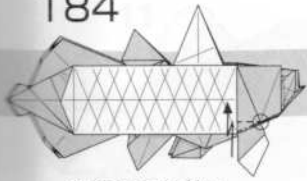

次の図を参考に
○を基準に段折り

185



ふちを折り込んで隠す

186

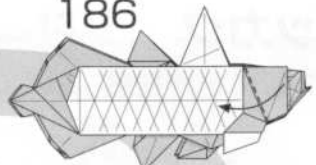

反対側にたおす

202

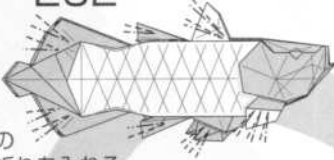

それぞれの
ひれに段折りを入れる
(ピンセットなどを使うとよい)

203

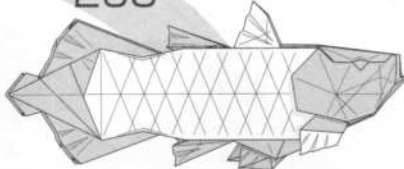

できあがり

187

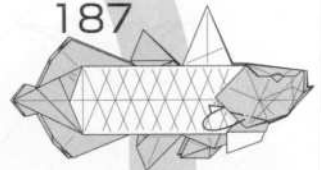

かどを少し折り込む

188

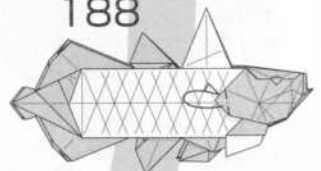

かどを少し折り込む

201

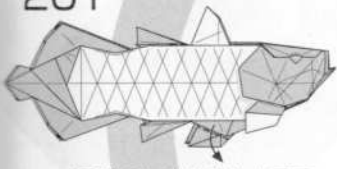

両側のかどを少し立てて
八の字にする

200

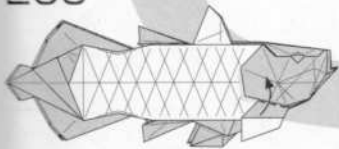

両側のかどを少し立てて
八の字にする

199

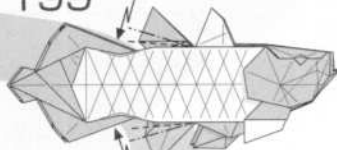

かどを段折り

198

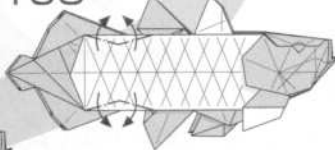

次の図を参考にふちを
少し凹ませる
(反対側も同じ)

197

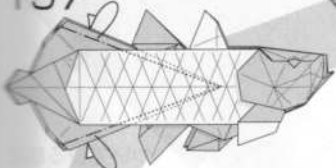

ふちを内側に折り込む
(反対側も同じ)

179-188

189

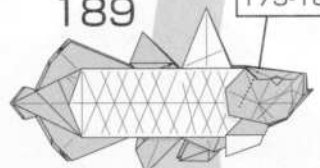

反対側も179-188と
同じように折る

190

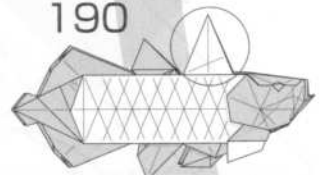

○のところを
拡大して見る

191



○を基準に
折り筋をつける

196



次から全体の図

195



次の図を参考に
内側に折り込む
(反対側も同じ)

194



ふちにあわせて
内側に折る

193



折ったところを
ひっくり返して
内側に隠す

192



○を基準に
ずらす
ように折る

イッカク

創作・折図:宮永智悠

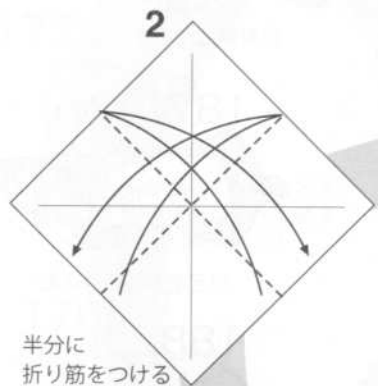
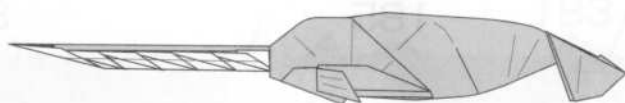

半分に
折り筋をつける

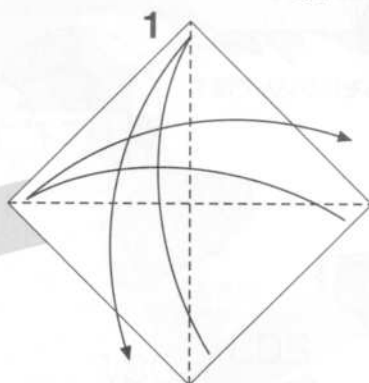

三角に折り筋を
つける

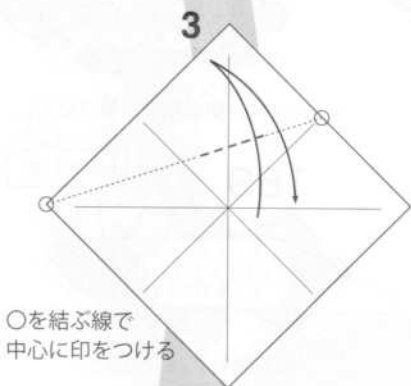

○を結ぶ線で
中心に印をつける

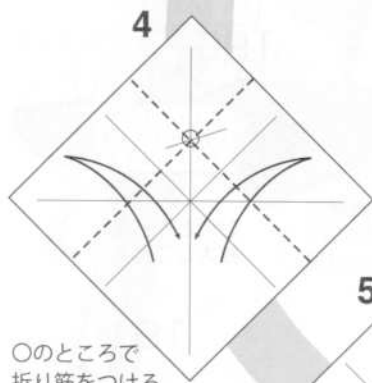

○のところで
折り筋をつける

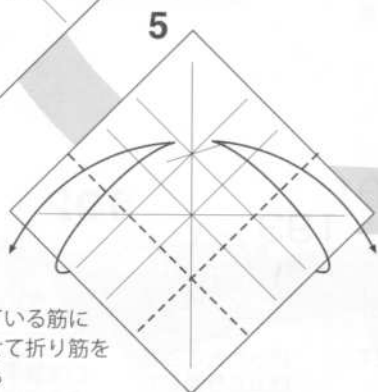

ついている筋に
あわせて折り筋を
つける

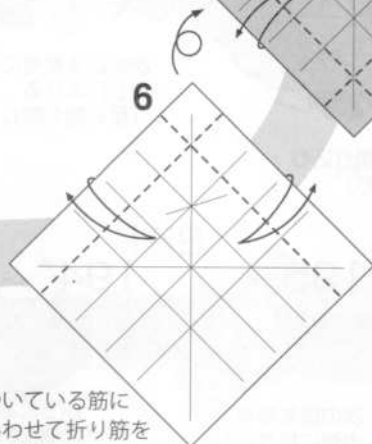

ついている筋に
あわせて折り筋を
つける

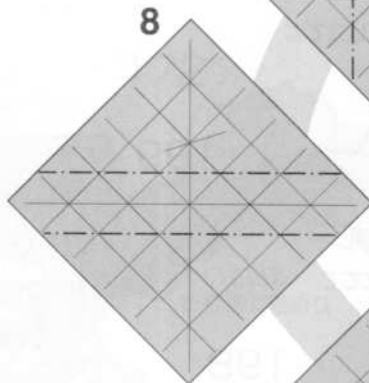

左右の紙を
引き寄せる
ように
折る

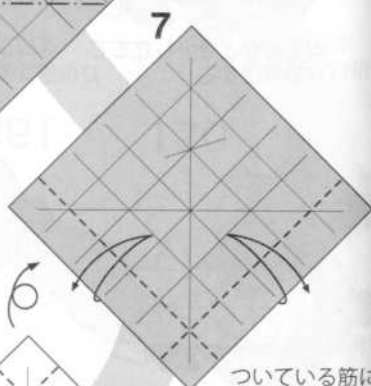
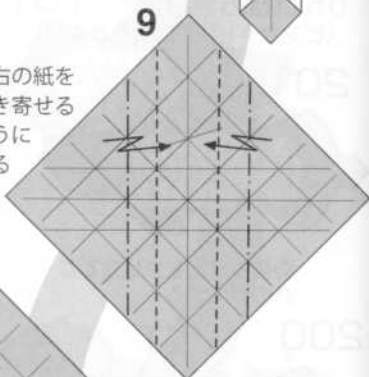

ついている筋に
あわせて折り筋を
つける

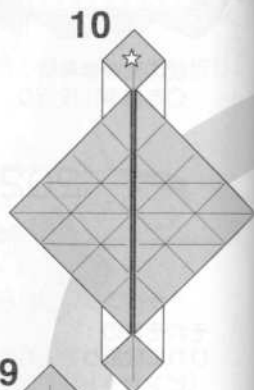

11

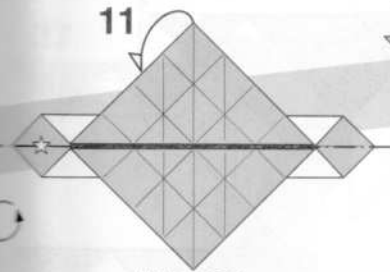

半分に折る

12

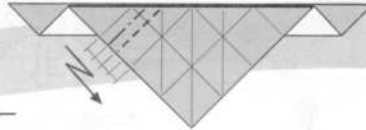

図の幅で段折り

13

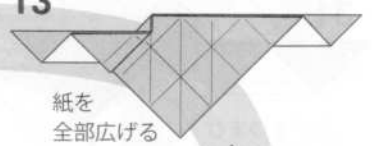

紙を
全部広げる

14

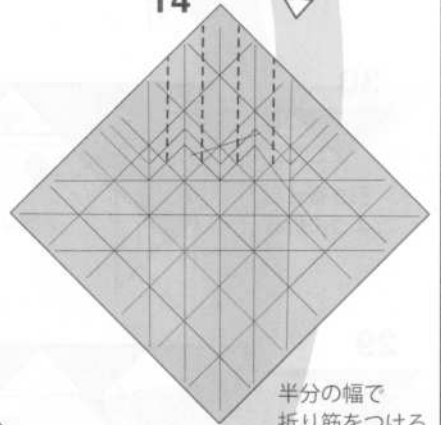

半分の幅で
折り筋をつける

17

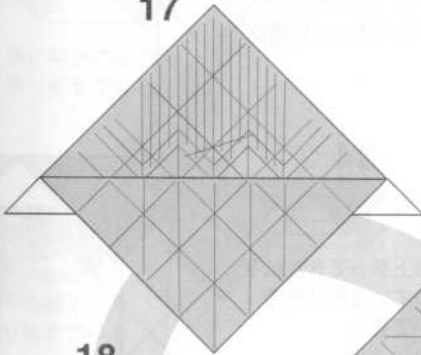

16

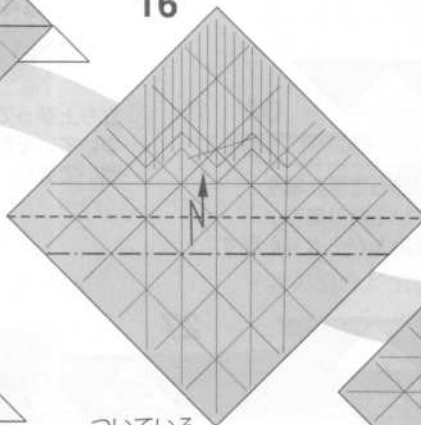

ついている
折り筋で段折り

15

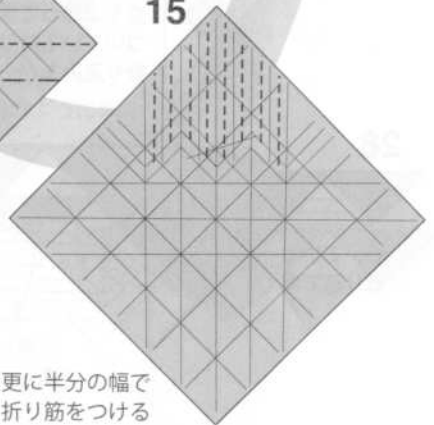

更に半分の幅で
折り筋をつける

18

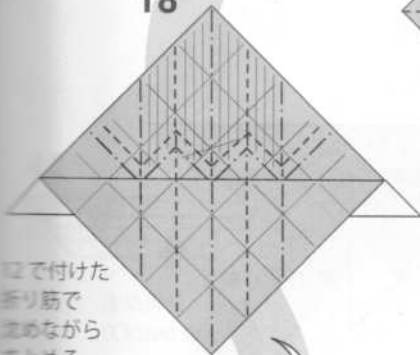

12で付けた
折り筋で
止めながら
まとめる

19

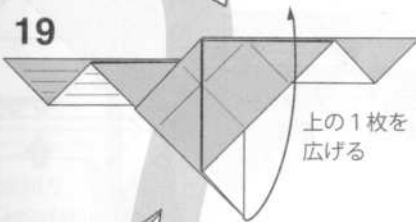

上の1枚を
広げる

20

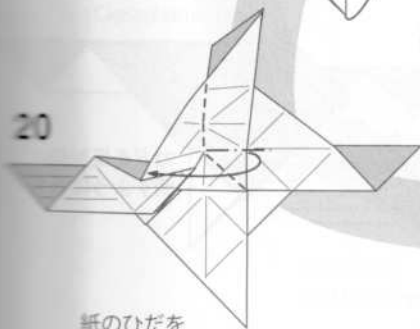

紙のひだを
反対側に倒すように折る

21

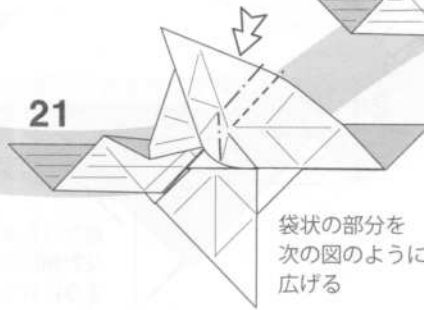

袋状の部分を
次の図のように
広げる

22

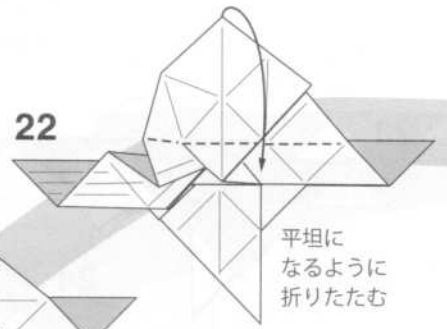

平坦に
なるように
折りたたむ

31

カドをつまむ
ように折る

32

中の紙を
引き出す

30

引き寄せ
るように折る

33

ついている
折り筋で少し開く

29

立ち上がってきた紙を
ついている折り筋で
折り込みながらカドを戻す

34

立ち上がってきた紙を
ついている折り筋で
開いて畳む

28

ついている
折り筋で開く

27

25の
形まで戻す

26

立ち上がってきた
紙を開いて畳む

23

24

重なった紙を
反対側に倒す
ように折る

25

カドを反対側に
倒すように折る

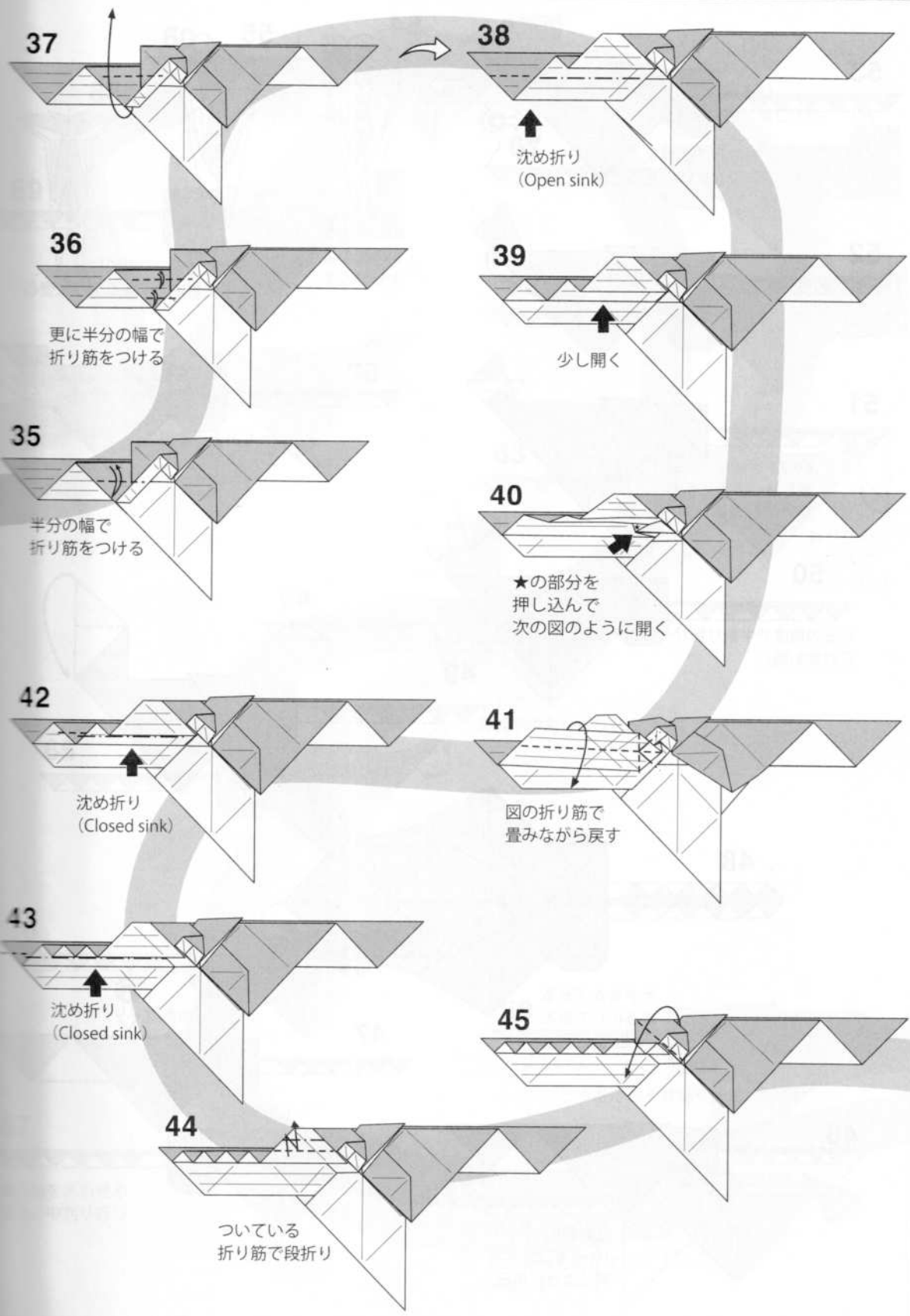

37

38

↑
沈め折り
(Open sink)

36

更に半分の幅で
折り筋をつける

39

↑
少し開く

35

半分の幅で
折り筋をつける

40

★の部分を
押し込んで
次の図のように開く

42

↑
沈め折り
(Closed sink)

41

図の折り筋で
畳みながら戻す

43

↑
沈め折り
(Closed sink)

45

44

↑
ついている
折り筋で段折り

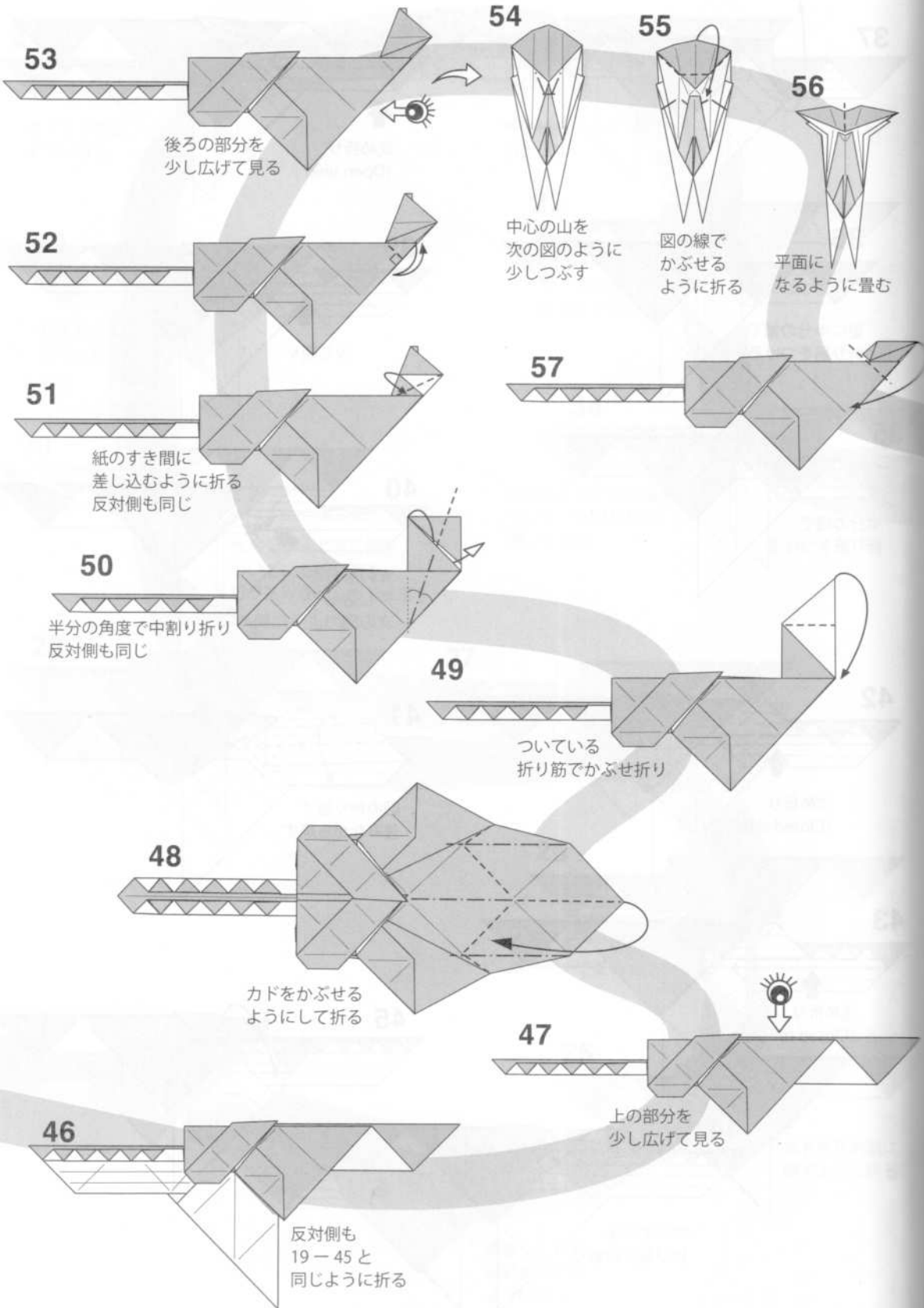

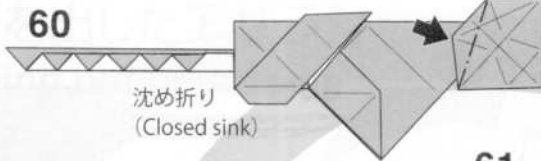

60

沈め折り
(Closed sink)

すぐ後ろの
すき間に差し込む

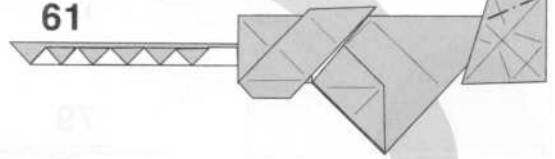

61

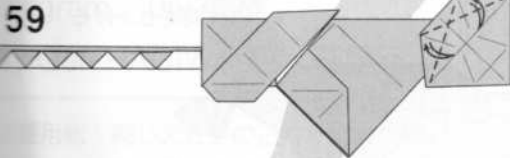

59

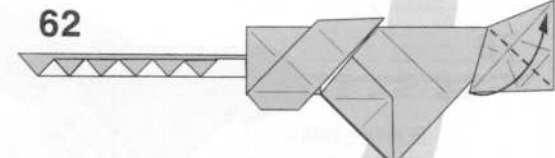

62

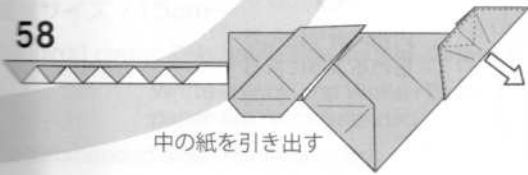

58

中の紙を引き出す

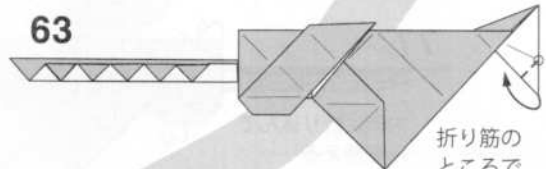

63

折り筋の
ところで
かぶせ折り

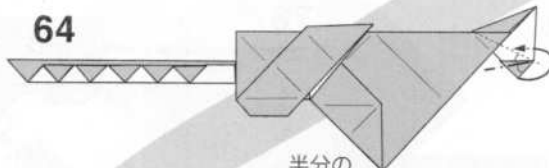

64

半分の
角度で中割り折り

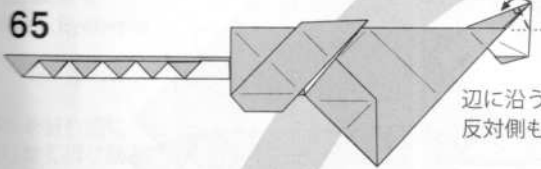

65

辺に沿うように折る
反対側も同じ

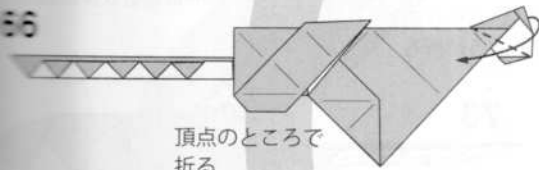

66

頂点のところで
折る
反対側も同じ

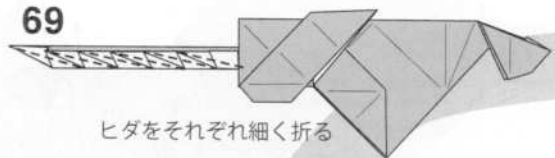

69

ヒダをそれぞれ細く折る

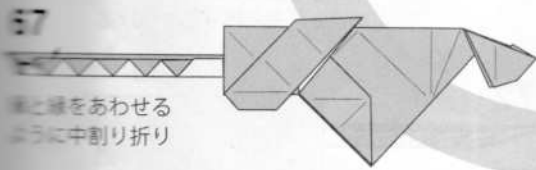

67

裏と表をあわせる
ように中割り折り

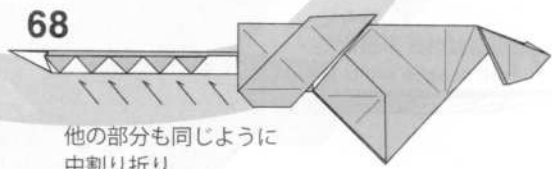

68

他の部分も同じように
中割り折り

81

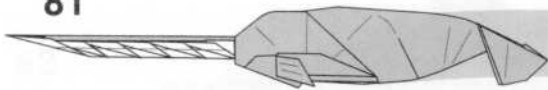

完成

80

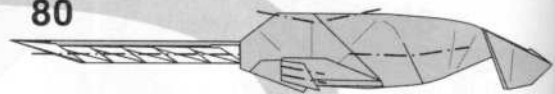

牙を細く整え
各部の形を仕上げる

79

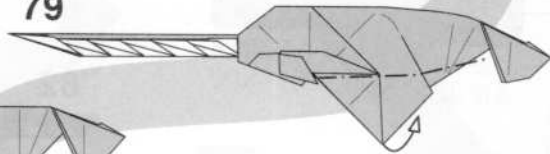

内側に折り込んで
留めるように折る

78

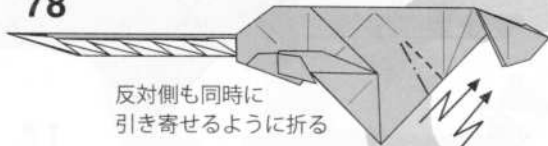

反対側も同時に
引き寄せるように折る

77

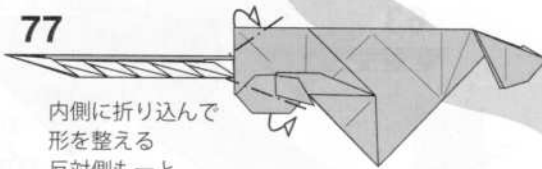

内側に折り込んで
形を整える
反対側も一と
同じように折る

76

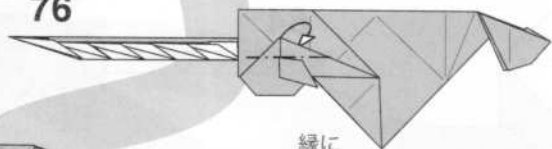

縁に
あわせるように折る

75

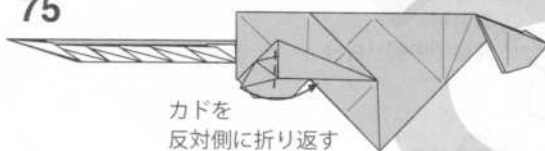

カドを
反対側に折り返す

74

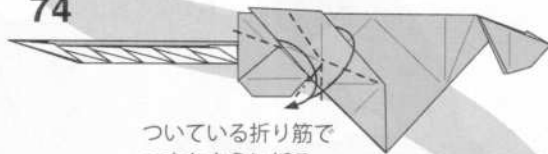

ついている折り筋で
つまむように折る

70



反対側も
67-69と
同じように折る

73

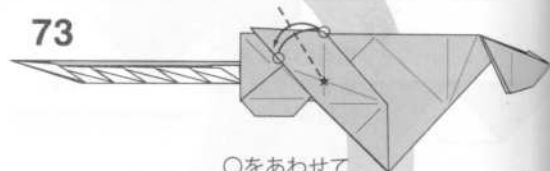

○をあわせて
★を通る折り筋をつける

71

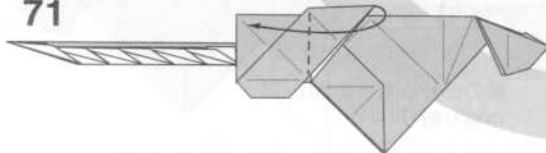

72

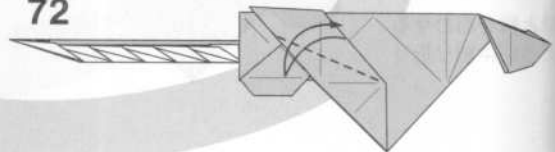

海から顔を出したアザラシ

Seal peeping out of the sea

Created: 03/2023

Diagram: 05/2024

By Gen HAGIWARA / 萩原元

必要用紙：同じ大きさの正方形2枚
 白と黒、白と水色の紙を推奨
 推奨サイズ：15cm～

Required paper: Two same size square sheets
 White+Black and White+Blue
 paper are recommended

Recommended size: 15cm or over

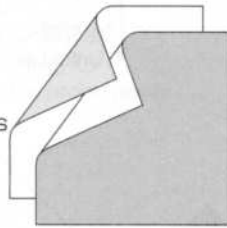
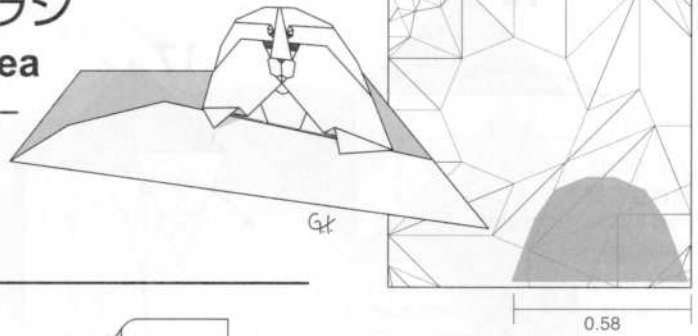

アザラシ / Seal

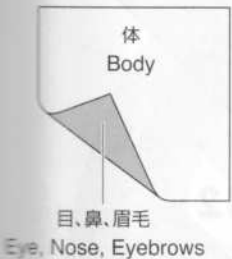

フチを折り筋に
 合わせて折り筋を
 つける
 Fold the edges to the
 crease line and unfold

フチを
 折り筋に
 合わせて
 折り筋をつける
 Fold the edges to the
 crease line and unfold

○を結ぶ線で
 折り筋をつける
 Fold along the line connecting
 the circled points and unfold

対角線に
 折り筋をつける
 Fold the diagonal.

フチを
 折り筋に
 合わせて折る
 Fold the edge to the
 crease line.

