



Rothenburg

Rothenburg ob der Tauber, commonly known as Rothenburg, is a town in Bavaria, a state in the south of Germany. Full of labyrinth-like alleys and wooden houses, this quaint town retains an air of the Middle Ages. The beautiful streets of Rothenburg are sometimes described as "a treasure chest of the Middle Ages," transporting visitors to a fairytale land.

The pieces of this paper craft can be nested inside one another like Russian matryoshka dolls. You can also display them in size order, with the biggest one at the front, to create a miniature town with a three dimensional perspective.

Assembly Instructions

- 1: Carefully cut out the parts. Write the part's number (A~J) on the back of each one.
- 2: Make mountain folds along the dotted lines, as indicated.
- 3: Attach the pieces together in order of the numbers on the glue spots, and assemble the parts.

- Parts sheet: 5 pages
- Number of parts: 10

*This model was designed for Papercraft and may differ from the original in some respects.

Handy Hints

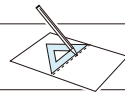

Trace along the folds with a used pen (no-ink) to get a sharp, easier fold.

Notation Key

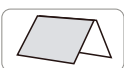

--- Mountain fold
● Make a mountain fold.



— Scissors line
● Cut along the line.

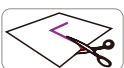

- - - Cut in line
● Make a cut.

Tools and Materials



Scissors, set square, glue (such as woodwork glue), metal rod, spatula, a used pen, toothpicks, tweezers (useful for handling small parts).

Assembly Tip



Before gluing, crease the paper along mountain fold and valley fold lines and make sure rounded sections are nice and stiff.

Caution



This craft requires the use of glue, scissors, tweezers, and other tools which may be dangerous to young children. Please keep them out of reach of children while you work.

Each house is assembled in the same way. Begin with the one you think looks the easiest size to make.

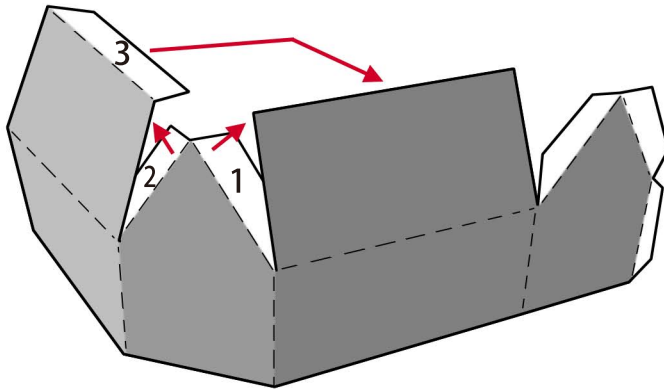

After attaching 1 and 2, line up the roof marked 3 and glue it down.

Glue the other side of the house by attaching 4, 5 and 6 in order, and you're done!

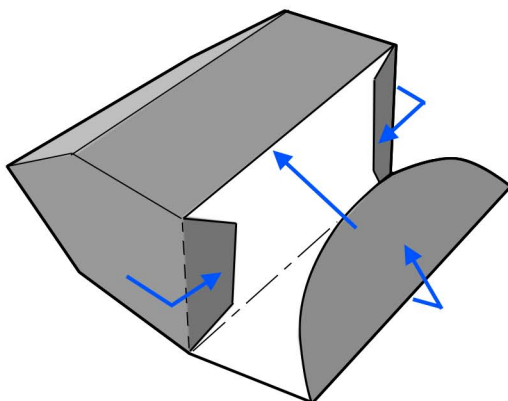
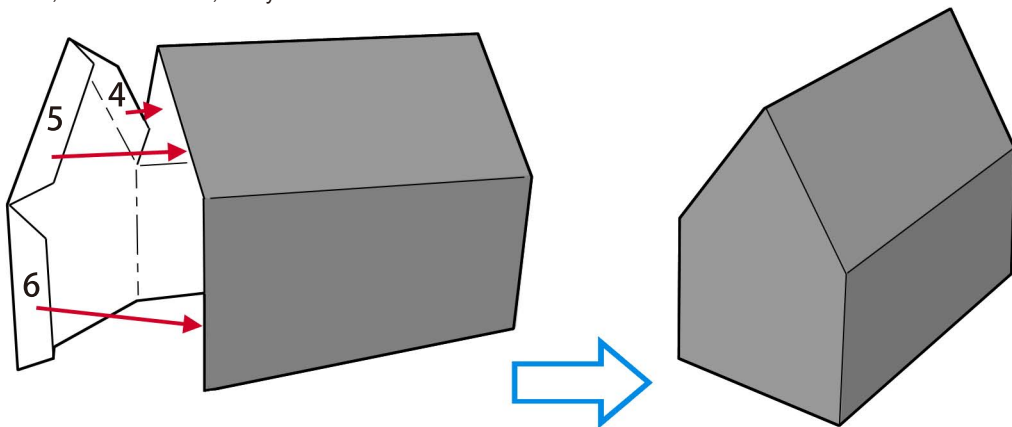

The biggest house, A, has a bottom to it. Make mountain folds as indicated, and insert the semicircle flap inside.

When not on display, put houses B to J inside house A, nesting each inside the bigger one, and close the lid.

