

Wolf Spider

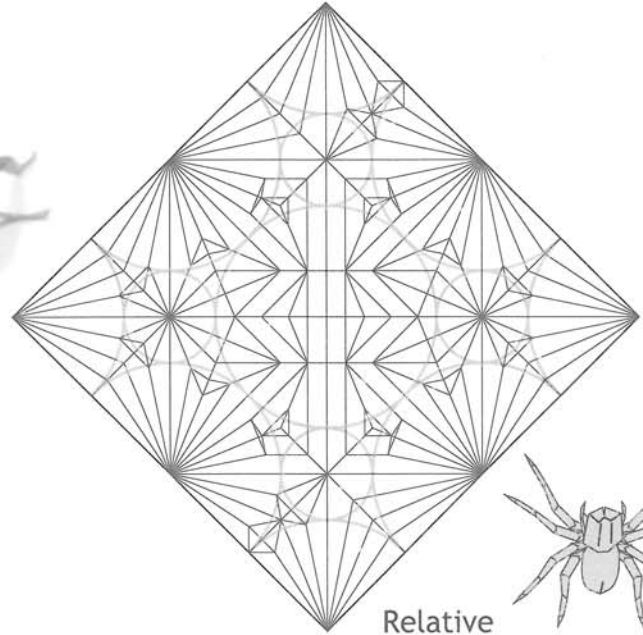

Designed by Brian Chan, 2009.
chosetec.darkclan.net/origami

This base of this spider is a blintzed frog base. The flaps are used asymmetrically, but the final model appears symmetric. Because the legs come from the corners and edges of the paper, the paper is used very efficiently.

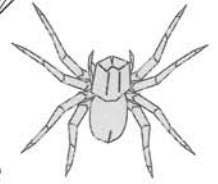

Relative size of folded model.

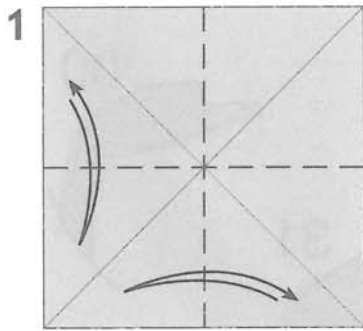

1 Crease vertically and horizontally.

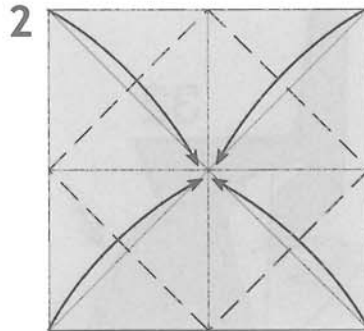

2 Blintz-fold.

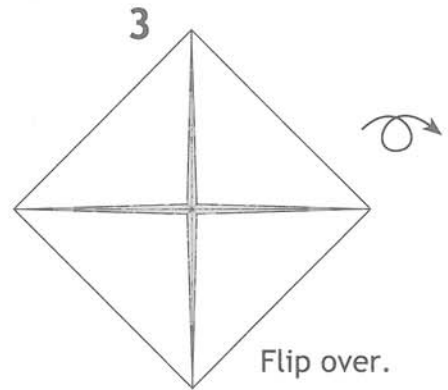

3 Flip over.

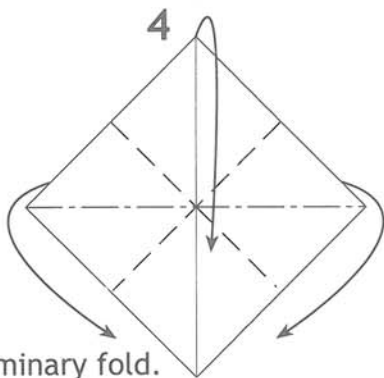

4 Preliminary fold.

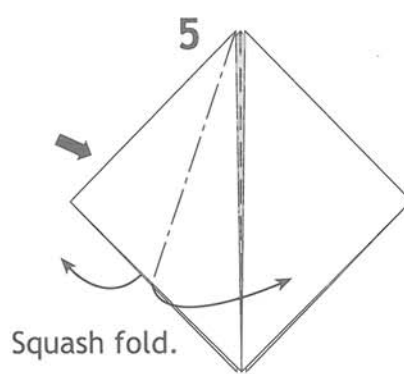

5 Squash fold.

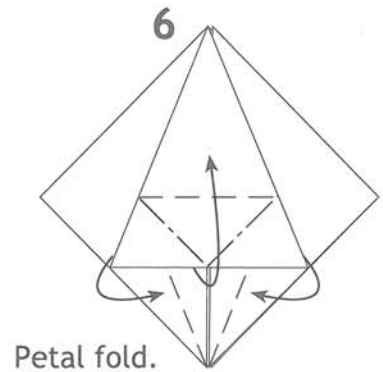

6 Petal fold.

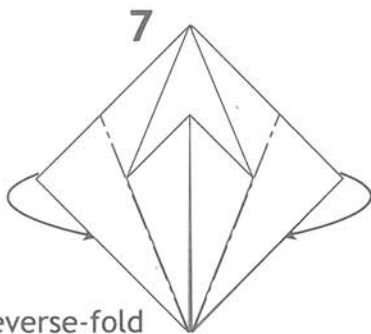

7 Reverse-fold the sides into the center.

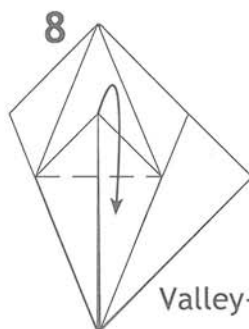

8 Valley-fold.

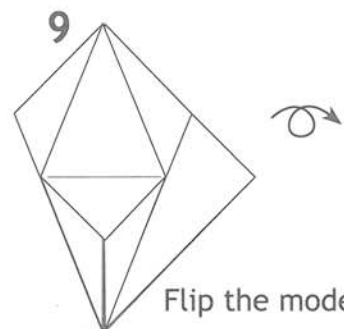

9 Flip the model.

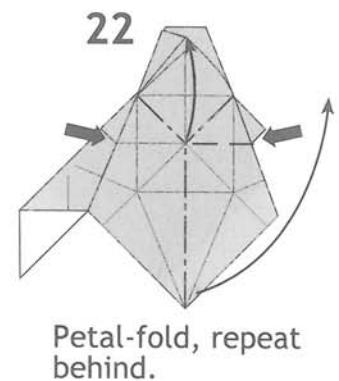
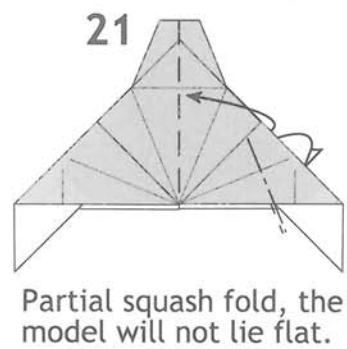
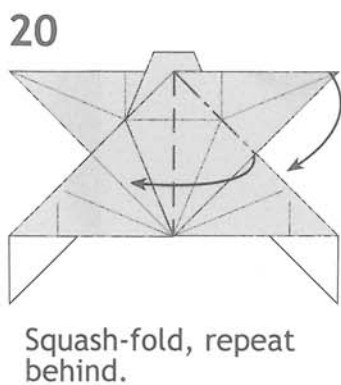
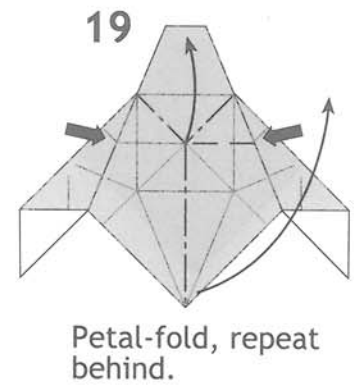
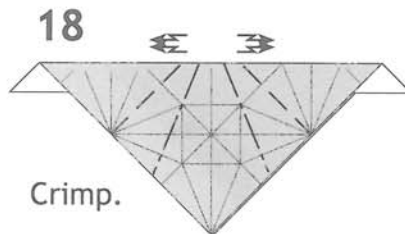
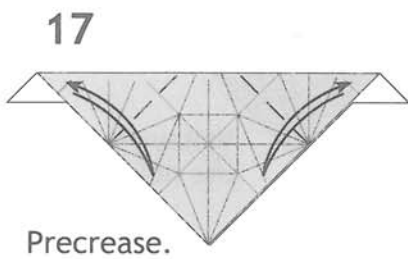
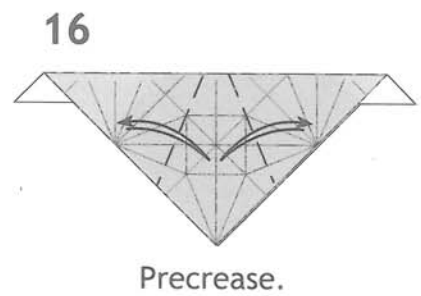
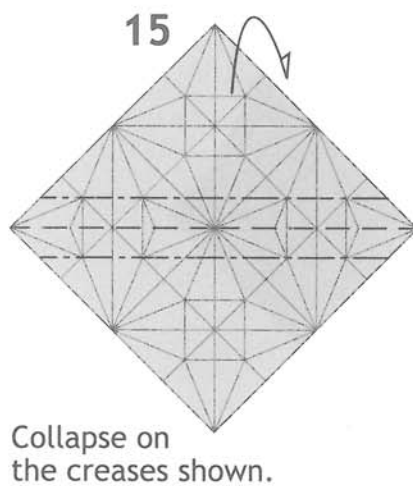
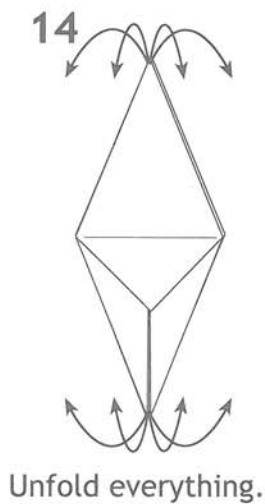
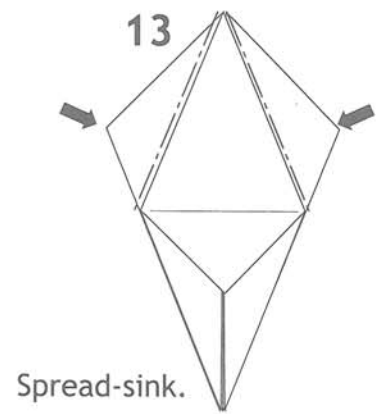
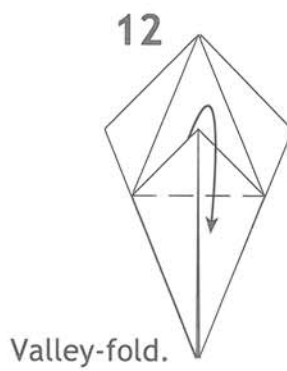
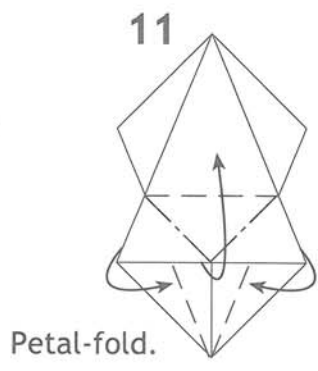
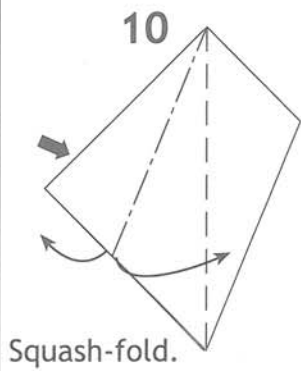

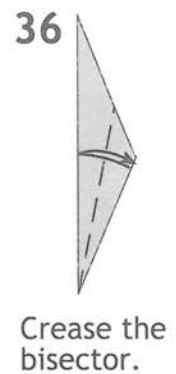
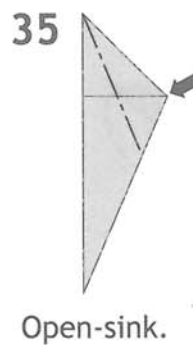
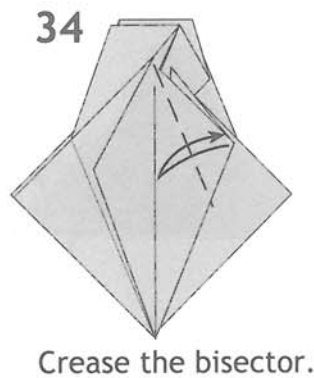
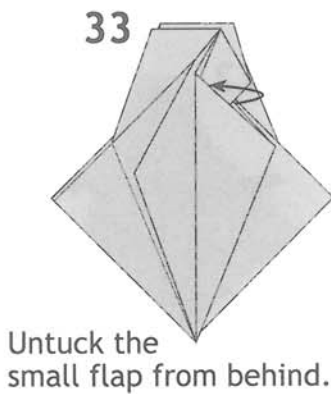
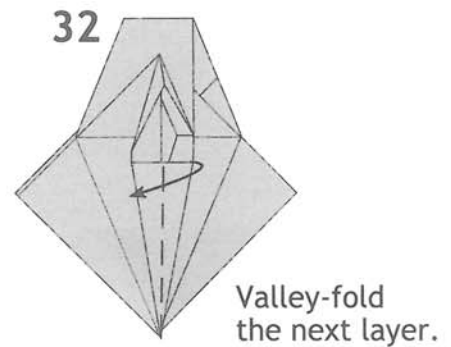
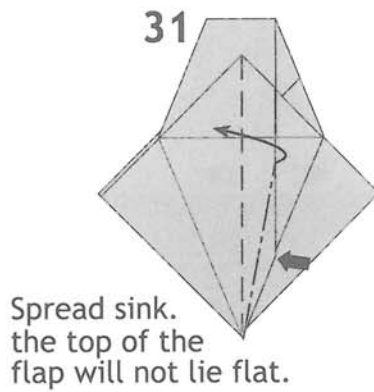
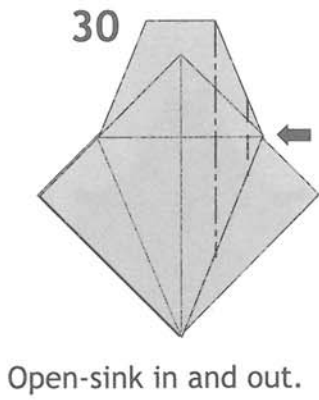
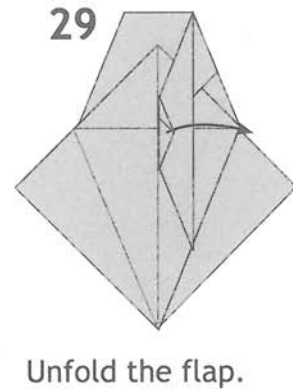
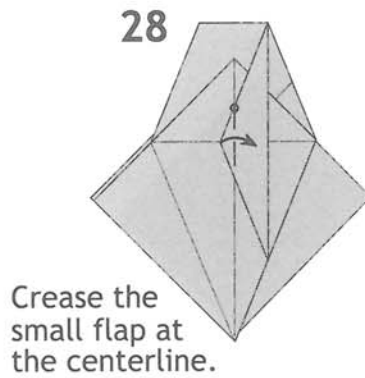
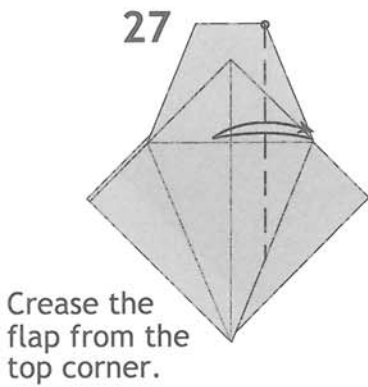
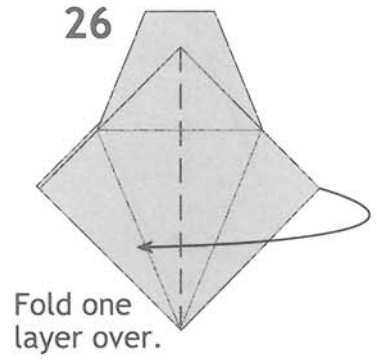
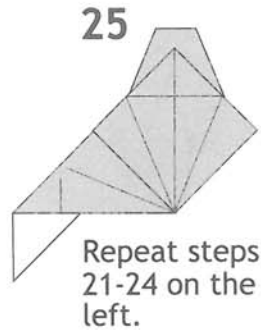
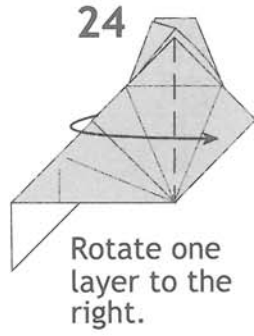
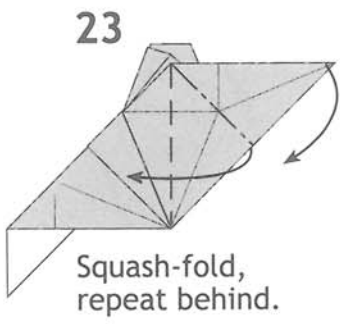

37

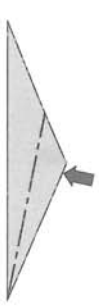

Open-sink.

38

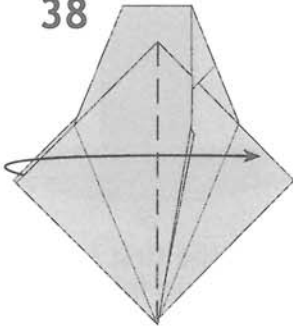

Valley-fold one flap.

39

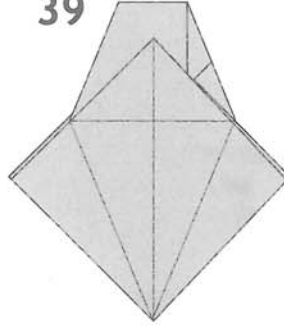

Repeat steps 26-38 three more times.

40

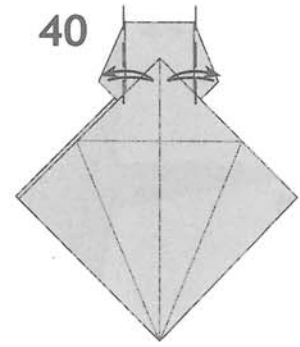

Crease along the vertical edge.

41

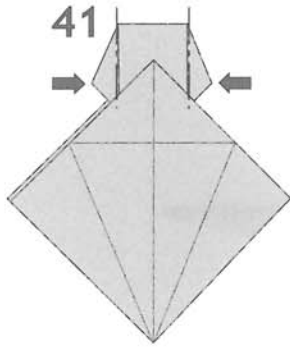

Open-sink.

42

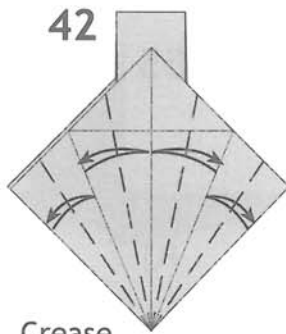

Crease the bisectors.

43

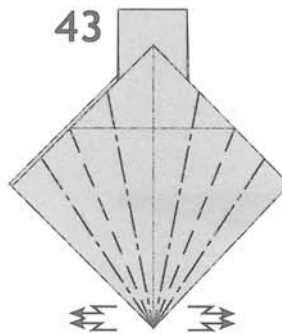

Crimp in and out.

44

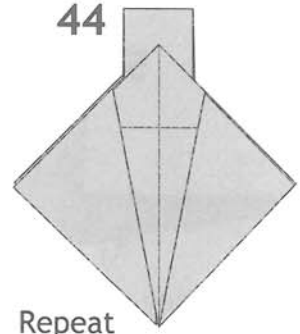

Repeat steps 42-43 on the sides and back.

45

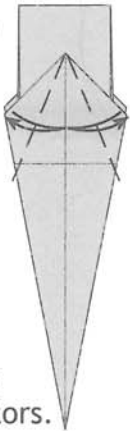

Precrease the bisectors.

46

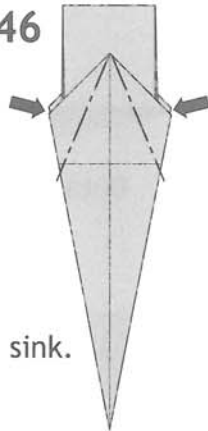

Open sink.

47

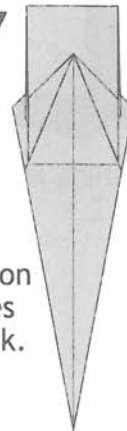

Repeat on the sides and back.

48

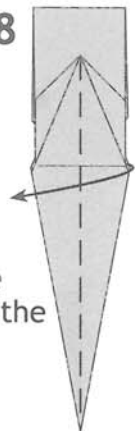

Fold one layer to the left.

49



Flip the model.



50



Fold one layer to the left. Note that this is not the mirror image of step 48.

51

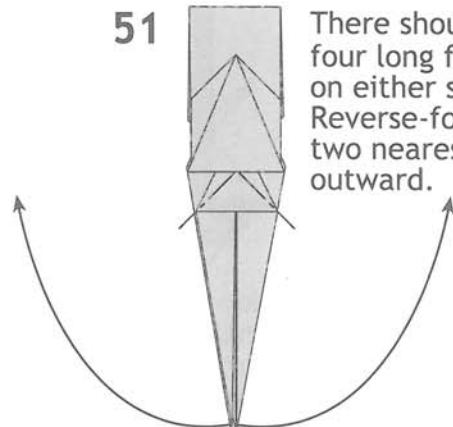

There should be four long flaps on either side. Reverse-fold the two nearest flaps outward.

52

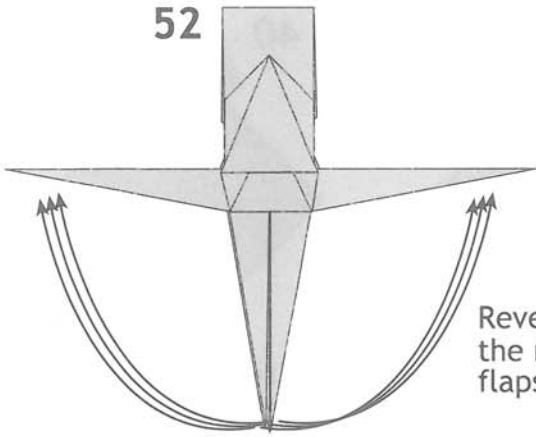

Reverse-fold
the remaining
flaps.

53

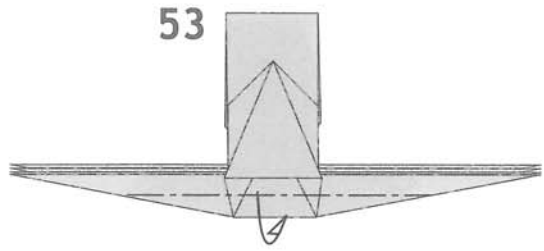

Thin the first layer with a
mountain-fold, repeat
behind.

54

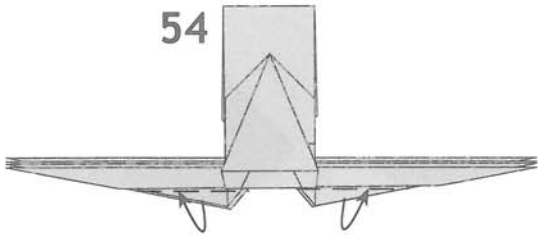

Valley-fold to thin the legs.

55

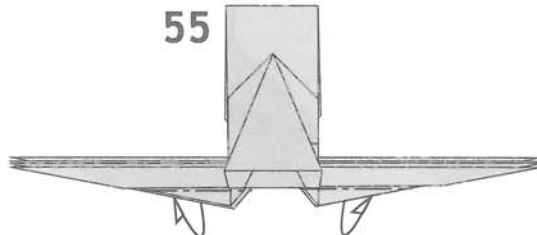

Mountain-fold the next layer.

56

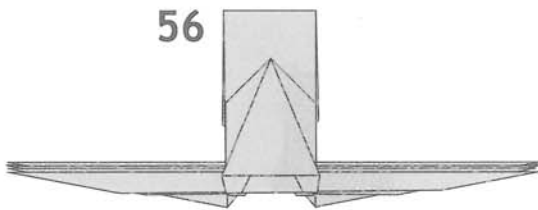

Thin the remaining legs.

57

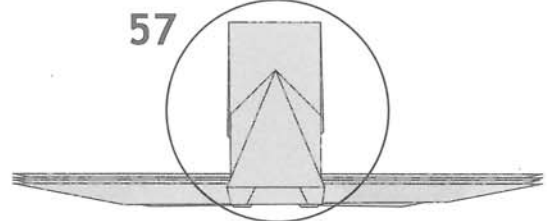

Detail of body.

58

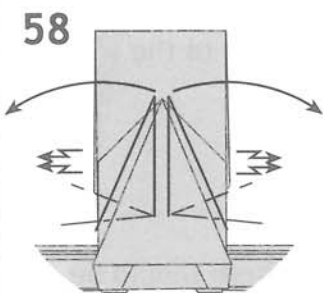

Pull out the two
hidden flaps,
using crimps.

59

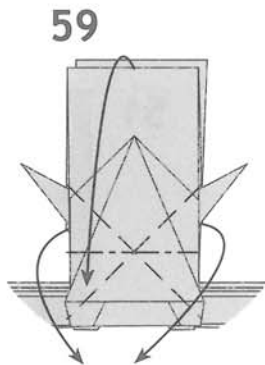

Fold down the rectangular
flap, making a waterbomb
in the middle for the two
side flaps. The model will
no longer lie flat.

60

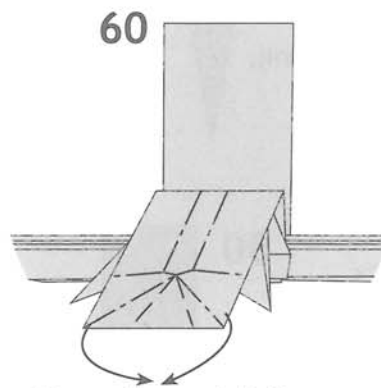

Shape the cephalothorax
(head and thorax) on the
creases shown.

61

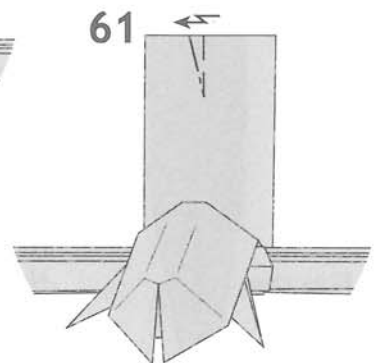

Pleat the tip of the
abdomen to give it
a 3D form.

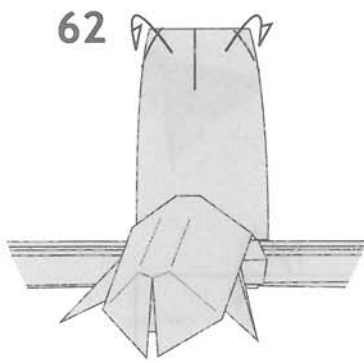

62 Round the corners of the abdomen.

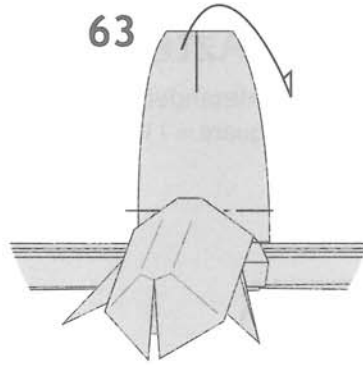

63 Mountain-fold the abdomen backward.

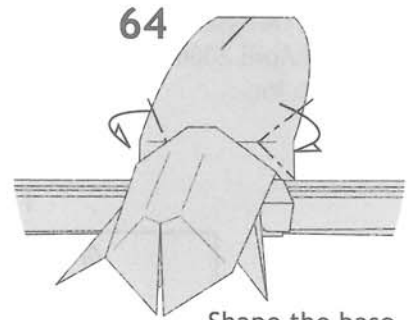

64 Shape the base of the abdomen.

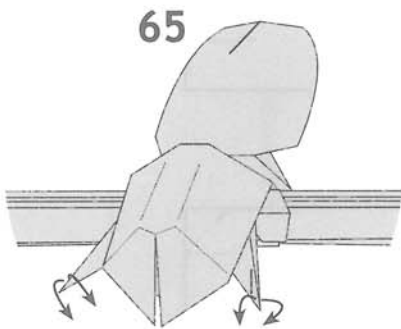

65 Pull out some paper to shape the palps (feelers).

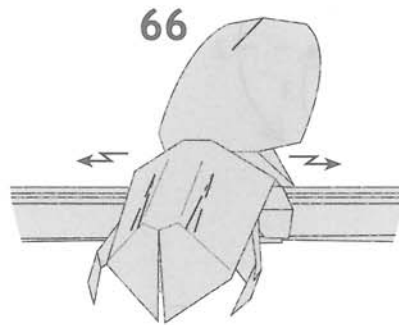

66 Pleat the sides of the cephalothorax.

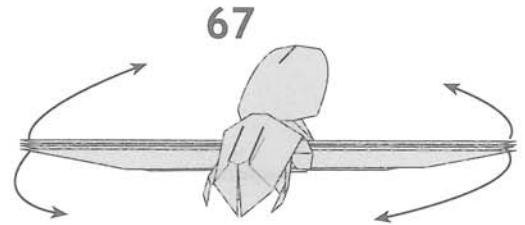

67 Spread the legs.

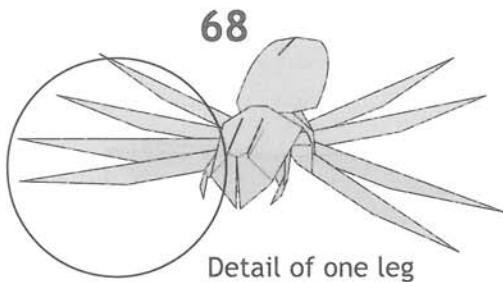

68 Detail of one leg



69 Crimp the base of the leg to angle it higher.

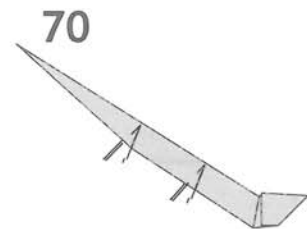

70 Bend the leg with crimps.

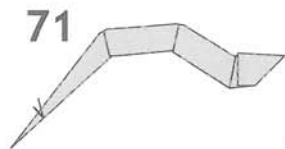

71 Shape the foot.

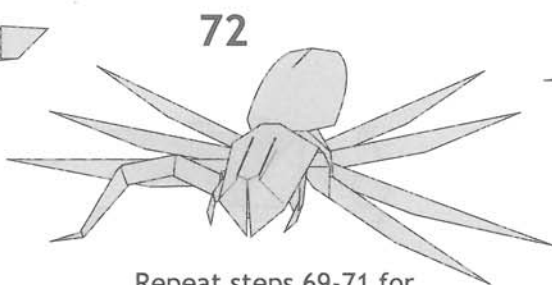

72 Repeat steps 69-71 for the remaining 7 legs.



Finished Wolf Spider.