

ELK 3.5

BY PHAM HOANG TUAN

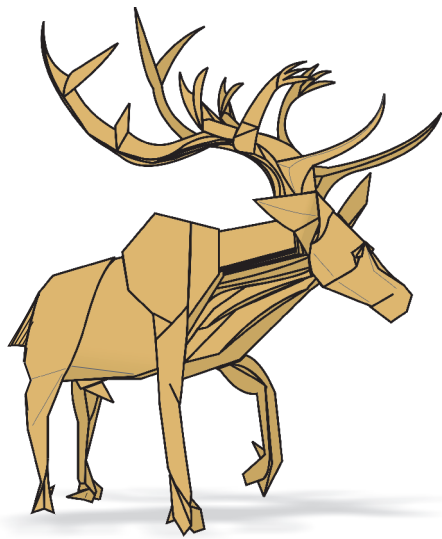

INSTRUCTION DIAGRAM



ELK 3.5

Phạm Hoàng Tuấn

30/04/2023

Level: ★★★★★
 Time to fold: 8 hours
 Paper size: 90x90cm

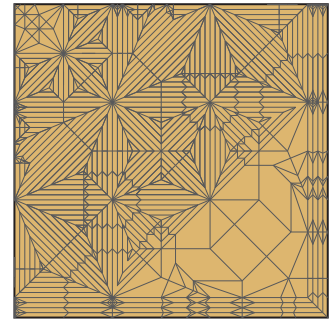

Elk is one of my favorite animals. I love the way it's head and horns look, they are massive and spectacular. The time I started to design origami art, I'd planned to create one from an uncut square of paper, with all real details. At that time, about 2012, it's such a hard time of my designing. I was lost in the mathematical methods of Origami. Sometimes the toughness prevented me from using math to make my dream come true.

Then until 2015, after three years of pressurising myself under the academic science of the art. I came to realize that Origami is not only a science, it's feeling and ambition. With the help of an old friend in the group of Southern Origami Society of Vietnam, he led me to apply feelings onto the paper, onto each crease. Someone has said that origami is art and math, but I think it is feelings, languages and life.

I started to create the elk, from the very first creases of a very basic form- the bird base. I spread my emotion onto the paper. Not focus much on the math, but the real feeling of a lively elk. Then, horn after horn, I folded the head, it appeared out what was exactly on my mind. It had two ears, a huge splendid pair of horns, eyes and even a mouth. Using experiences, I continued on the body with every single part. When I finished test-folding. I drew up the crease pattern, which is a diagramed way to memorise all the creases of a model.

I started to make my own paper to fold it, from a large sheet of oil paper, I used a special solution of glue and chemicals so that it was stronger and thinner. After all, the folding began.

I finished with the basic structure after 10 hours of folding. Which opened the hardest part, the shaping process. I looked at the pictures of the real elks on the internet. That's a great deal. Also, I looked at the works of the other authors. Yet, at that time hardly anybody, to me, had made a truly lively one. I came to make an elk that is looking forward ahead, with curiosity and strength, which I think, is the final work after 3 years of planning, designing and folding.”

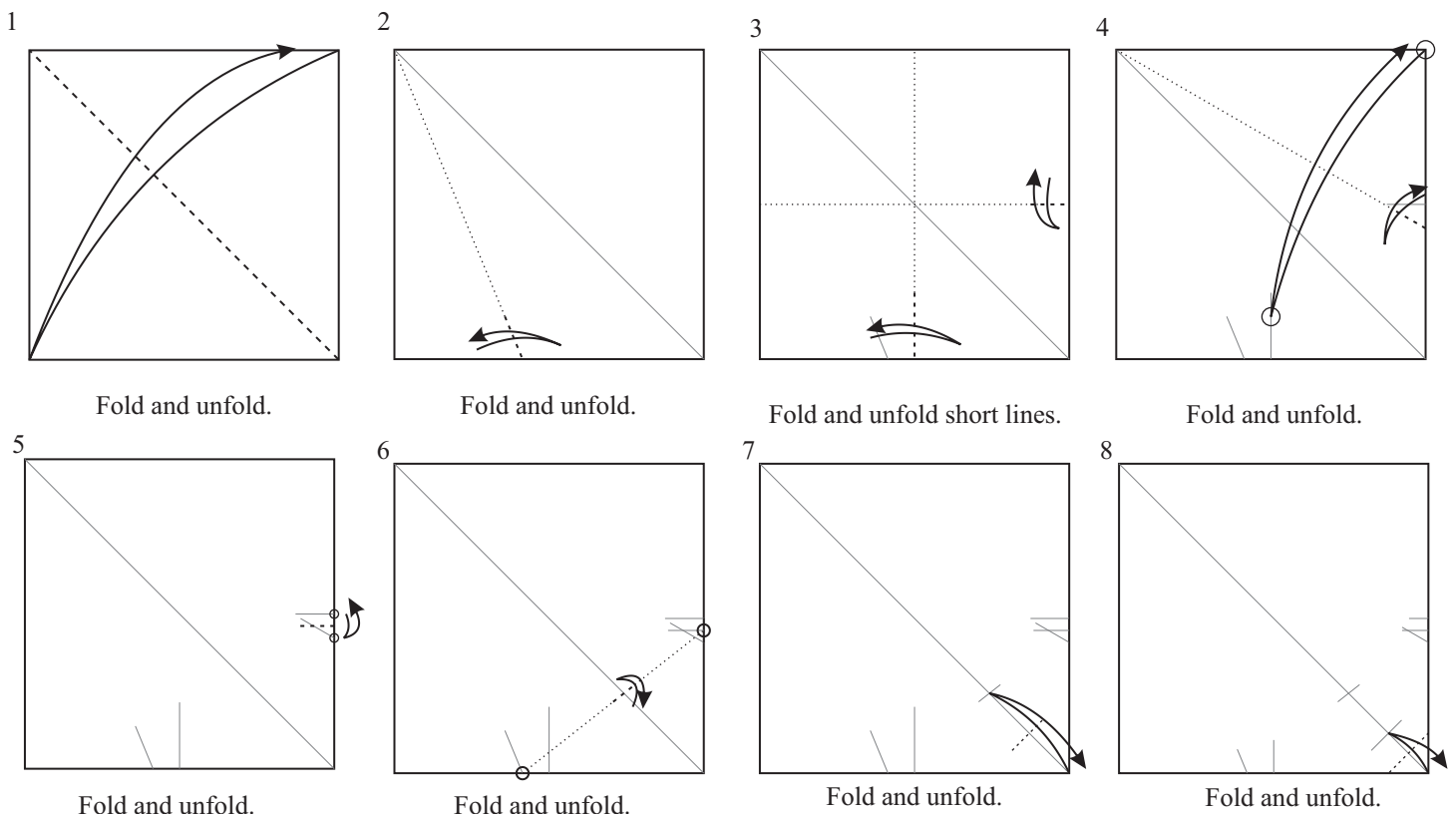

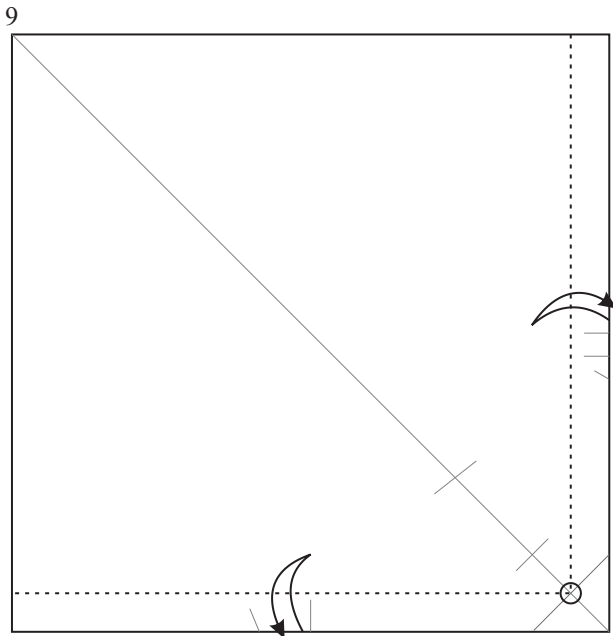

Fold and unfold.

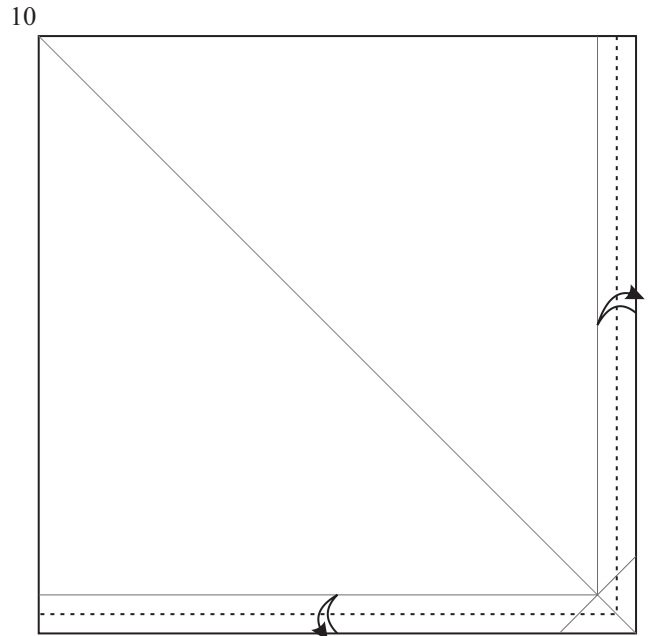

Fold and unfold.

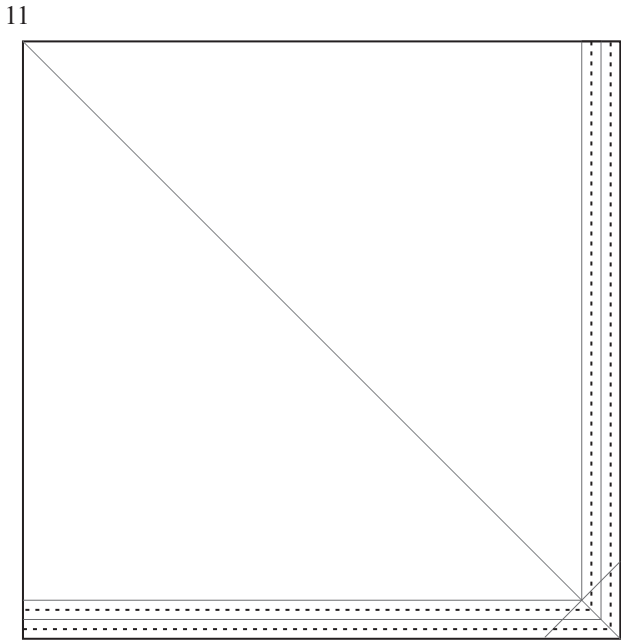

Keep making creases.

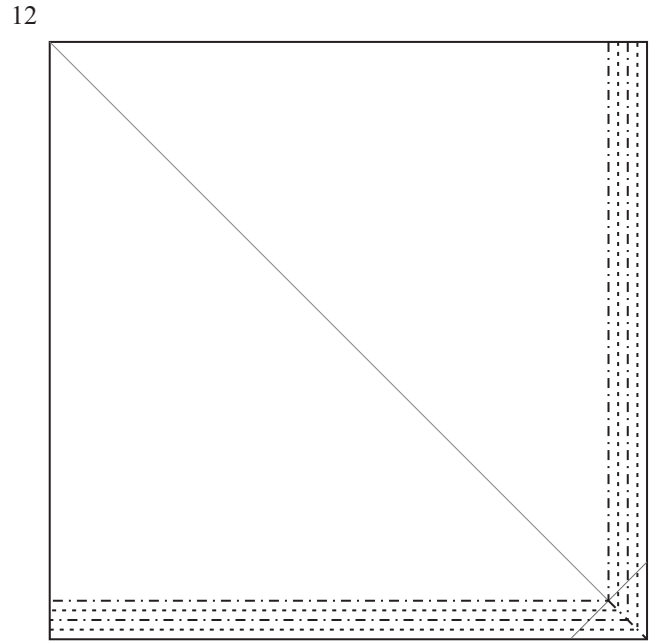

Collapse the edge box-pleating.

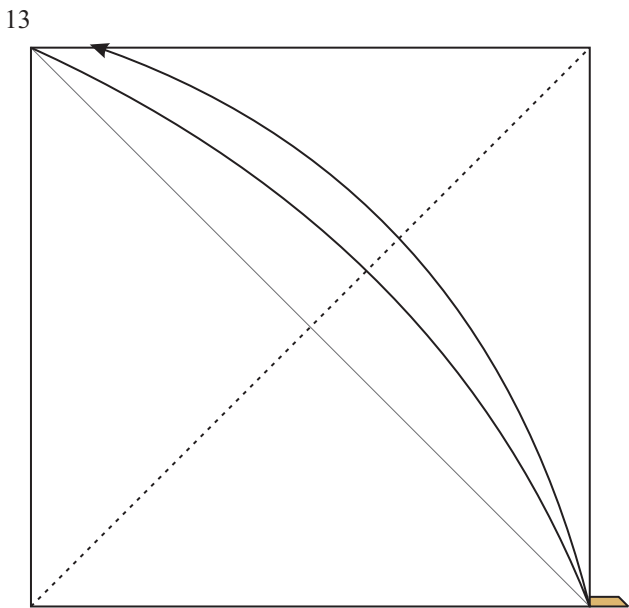

Fold and unfold.

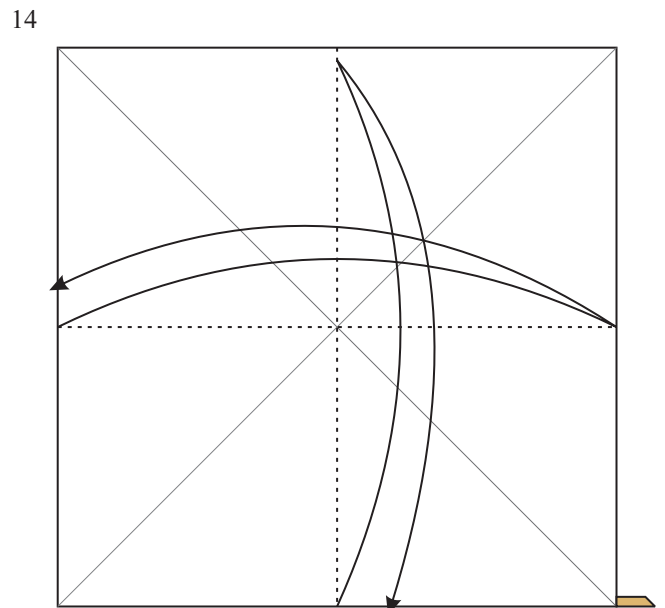

Fold and unfold.

15

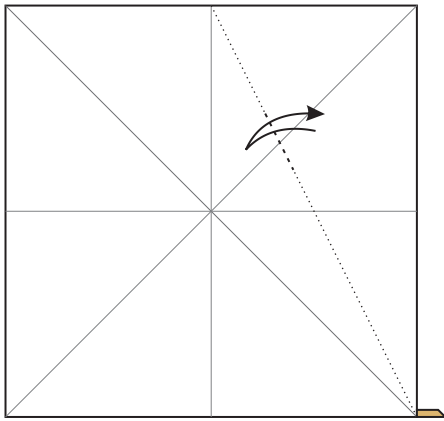

Fold and unfold short line.

16

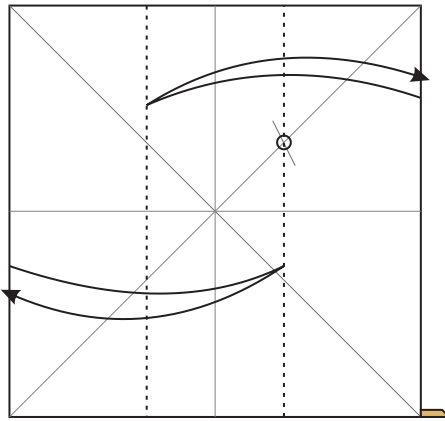

Fold and unfold.

17

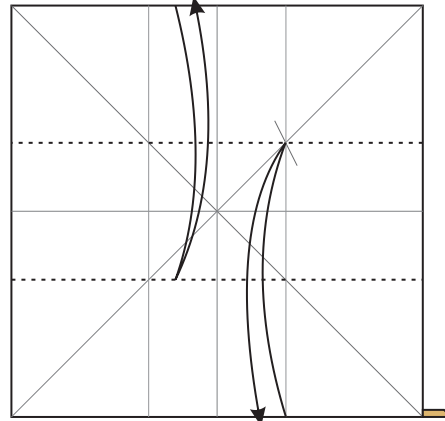

Fold and unfold.

18

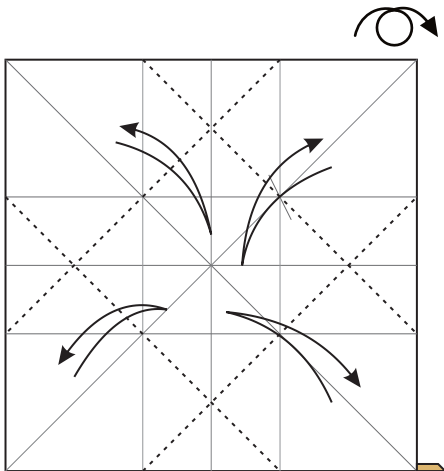

Fold and unfold. Turn over.

19

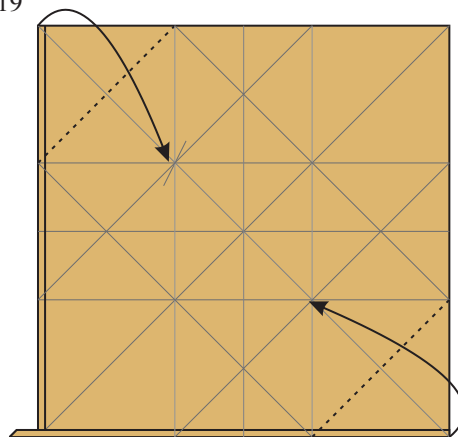

Valley fold.

20

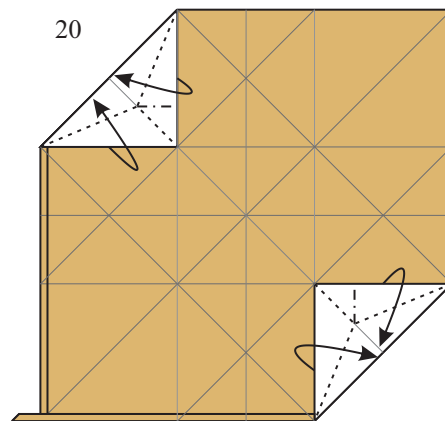

Rabbit-ear fold.

22

21

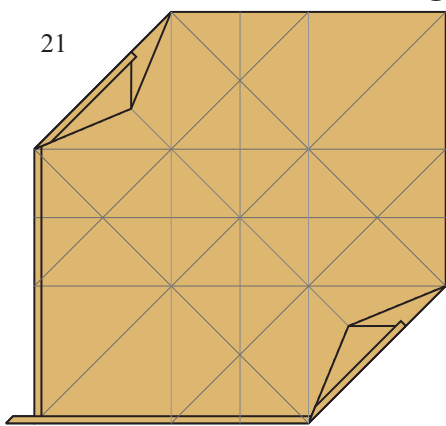

Turn over.

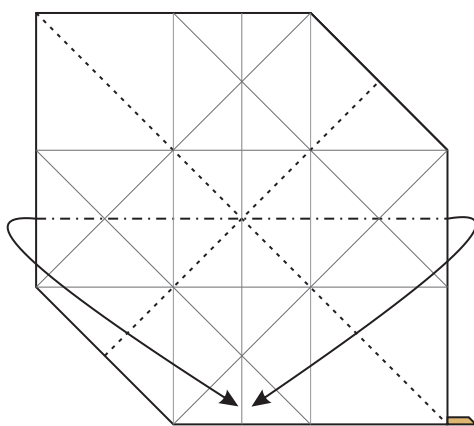

Collapse like water-bomb base.

23

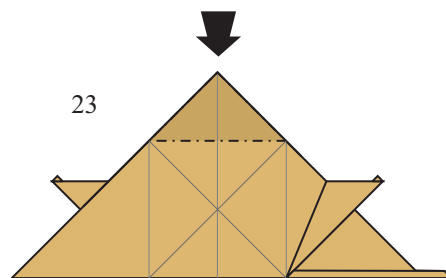

Open sink.

24

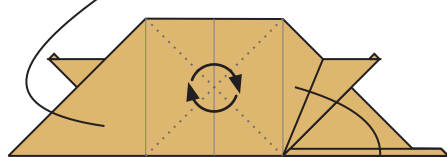

Use the circled point as the rotation center, rotate the layer by making some hidden valley fold beneath.

25

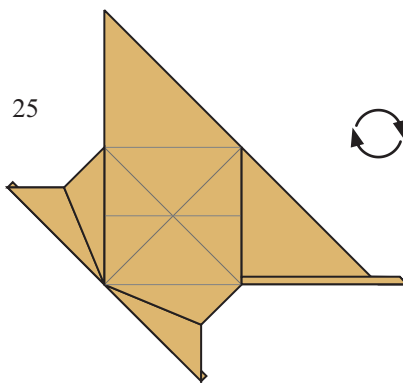

The result should be like this, rotate.

26

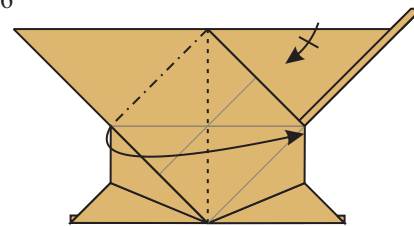

Squash fold, repeat behind.

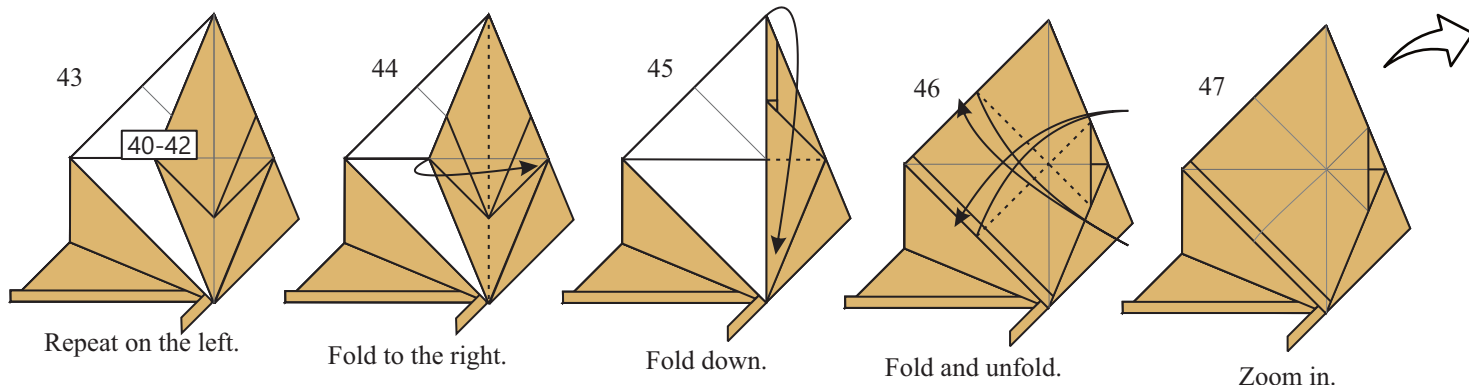
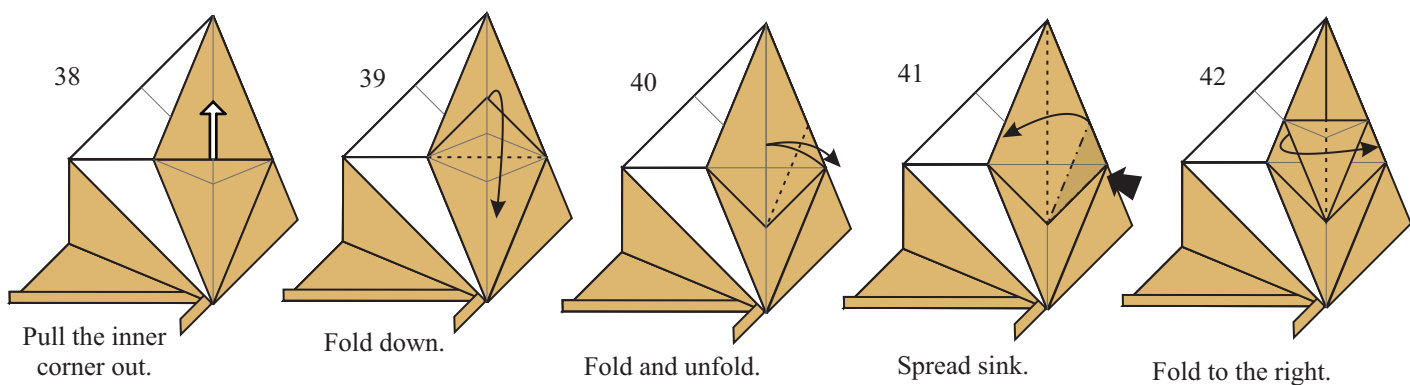
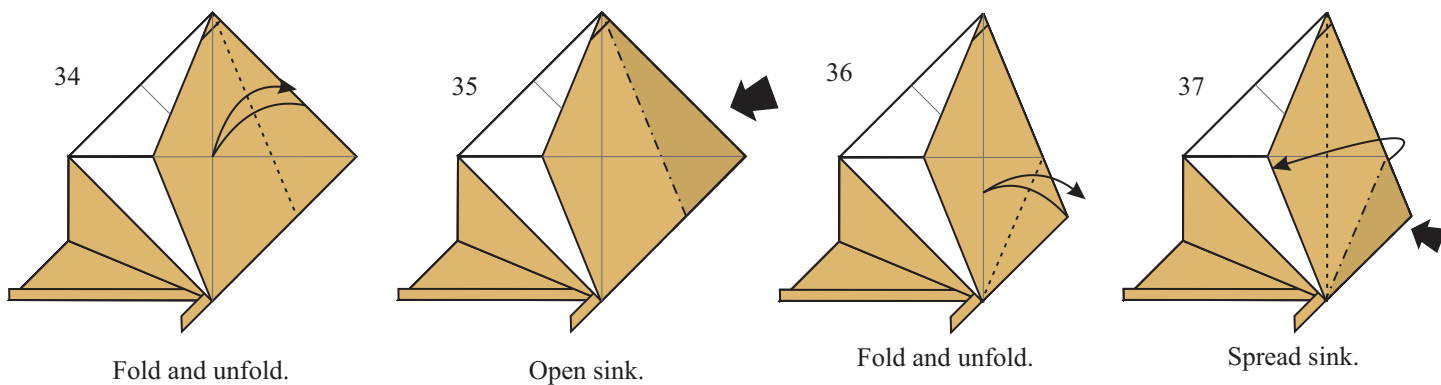
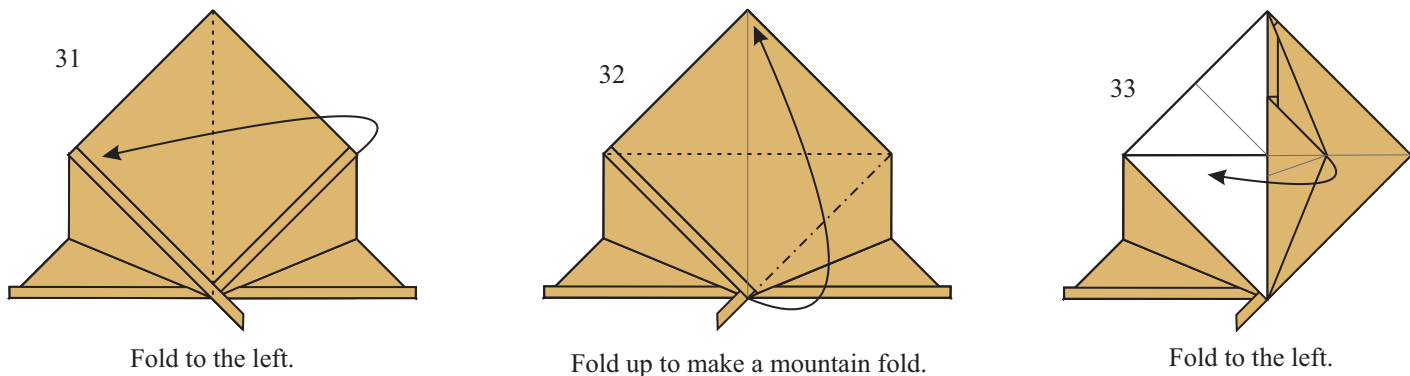
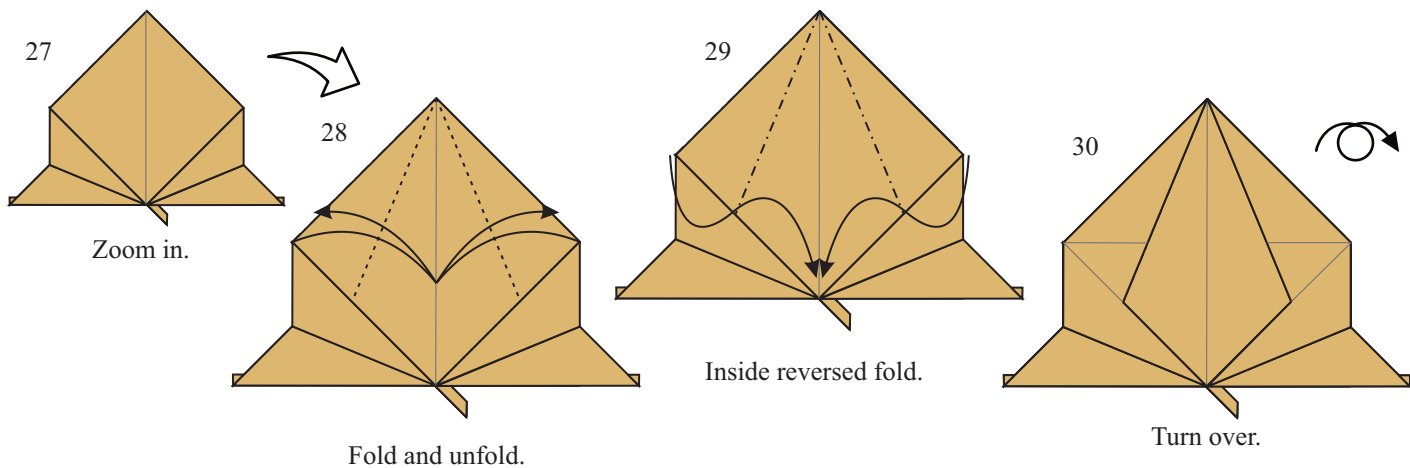

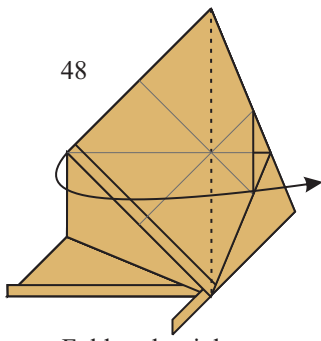

48

Fold to the right.

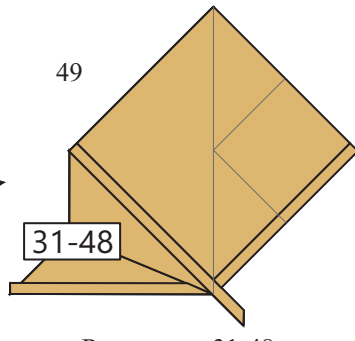

49

31-48

Repeat step 31-48 on the left.

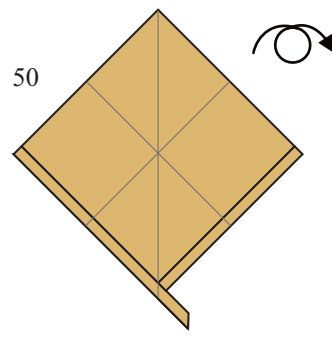

50

Turn over.

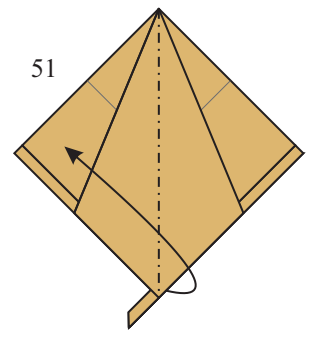

51

Rise up the flap.

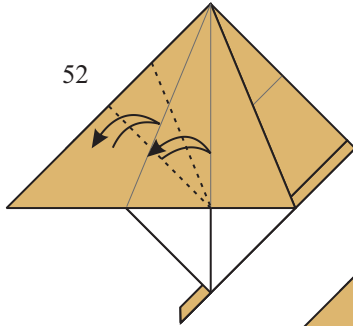

52

Fold and unfold.

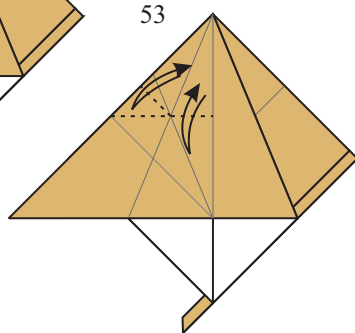

53

Fold and unfold.

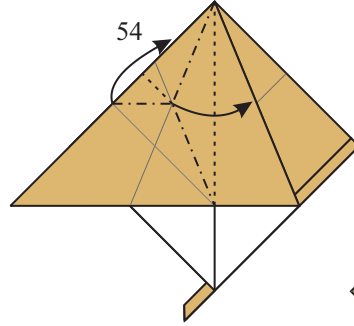

54

Fold the corner to the right to rise up the pocket.

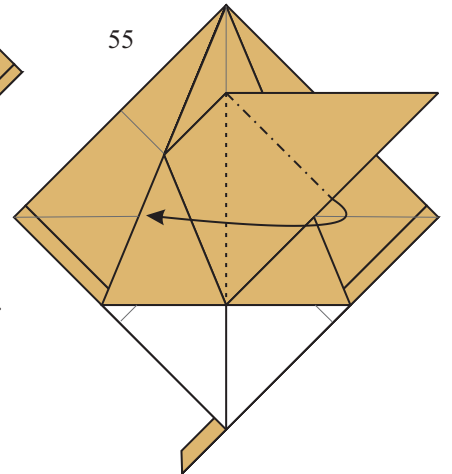

55

Squash fold.

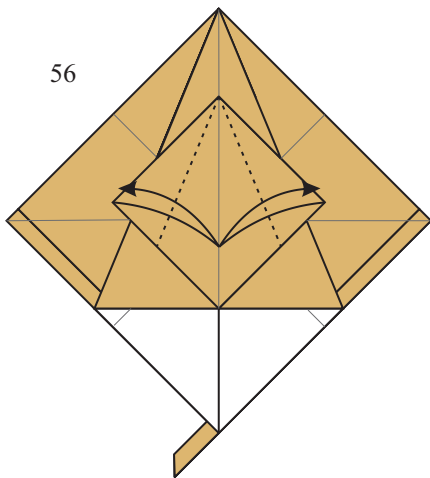

56

Fold and unfold.

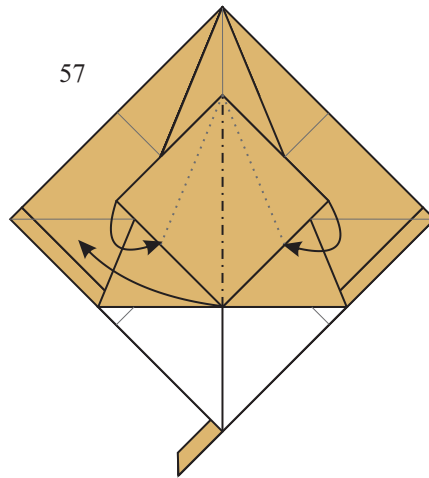

57

Reversed fold to rise up the flap.

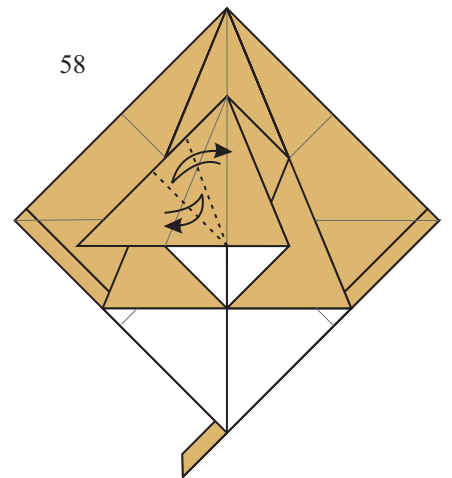

58

Fold and unfold.

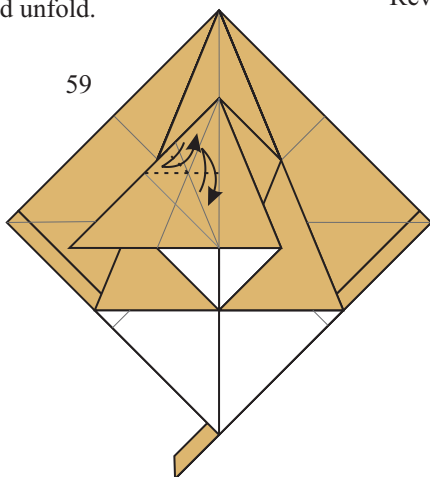

59

Fold and unfold.

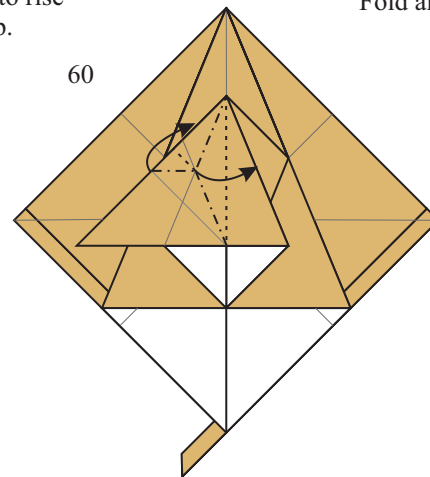

60

Fold the corner to the right to rise up the pocket.

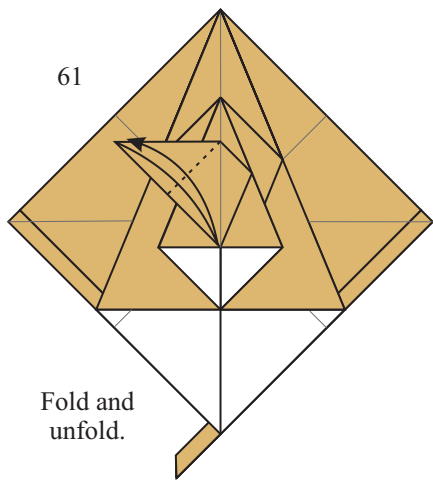

Fold and unfold.

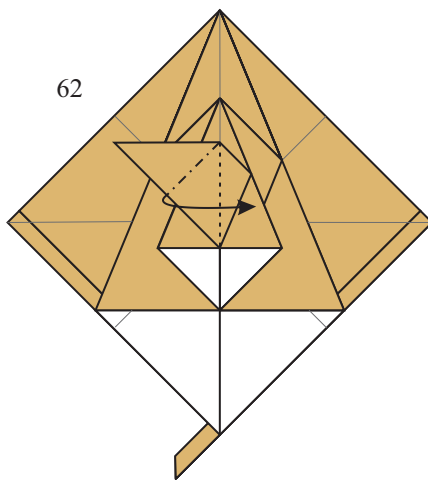

Squash fold.

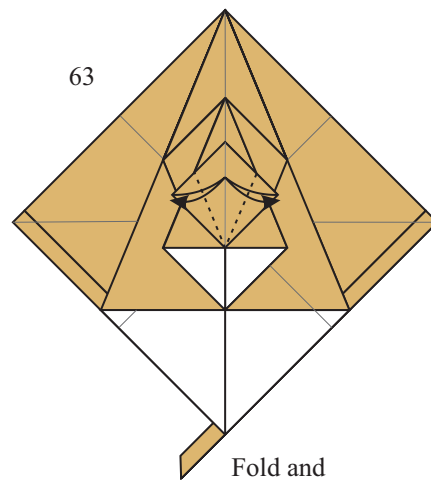

Fold and unfold.

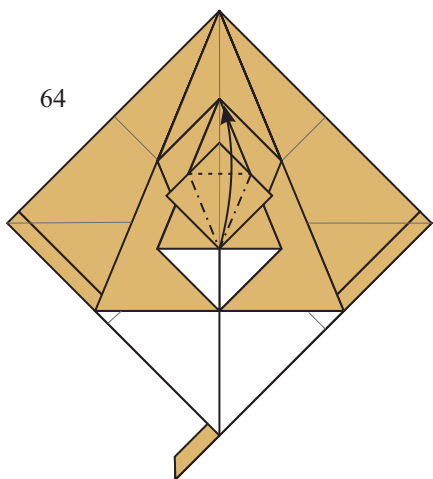

Pedal fold up.

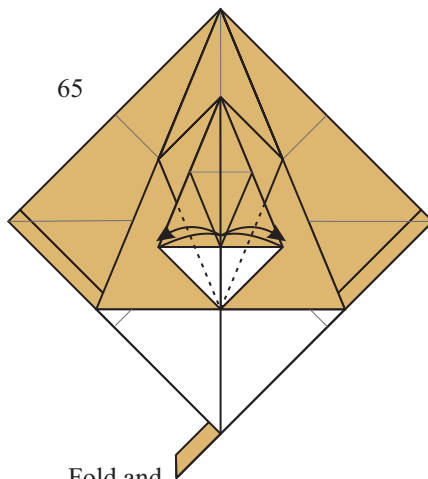

Fold and unfold.

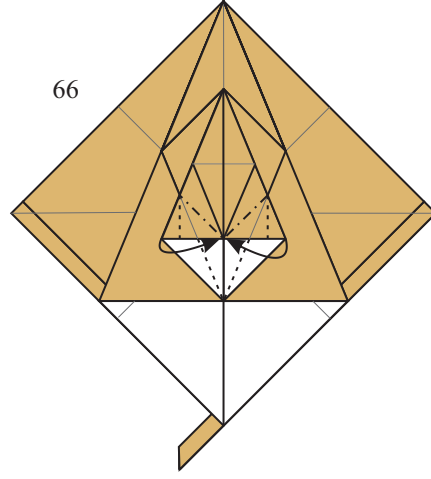

Inside reversed fold.

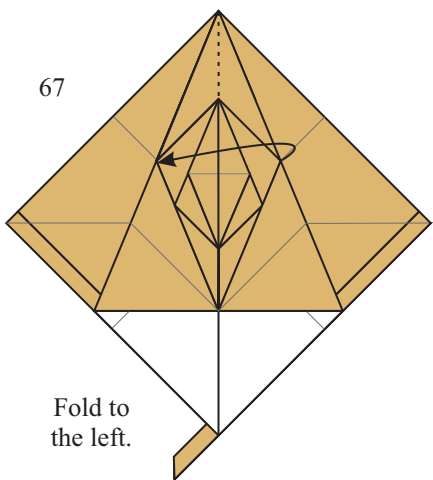

Fold to the left.

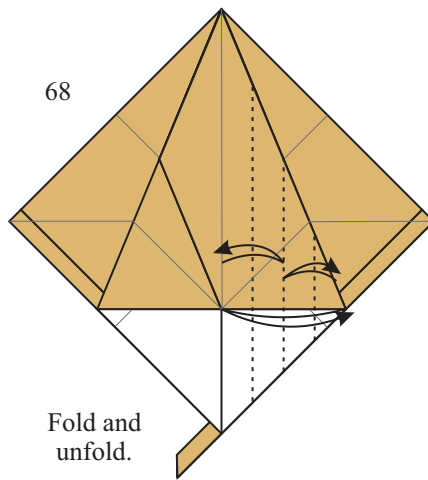

Fold and unfold.

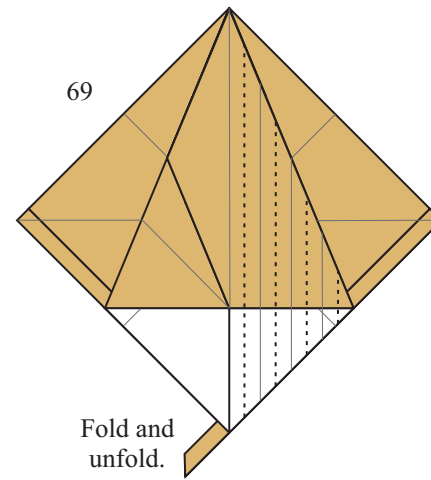

Fold and unfold.

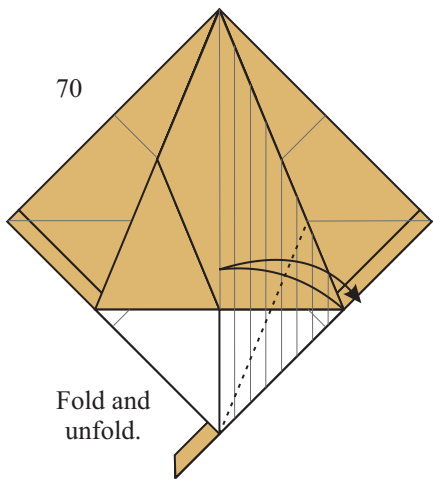

Fold and unfold.

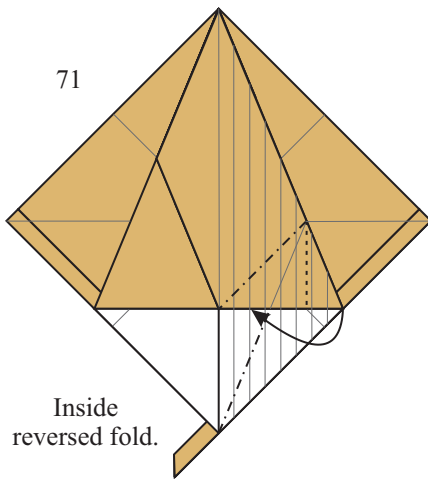

Inside reversed fold.

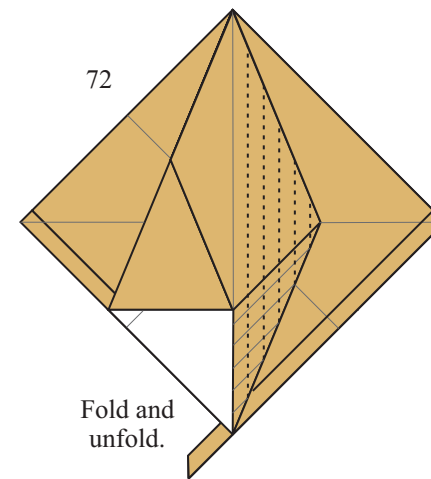

Fold and unfold.

73

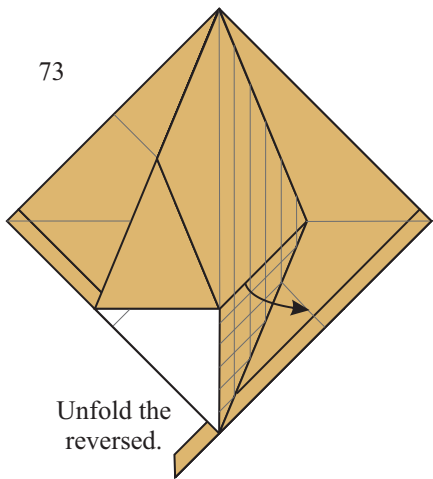

Unfold the reversed.

74

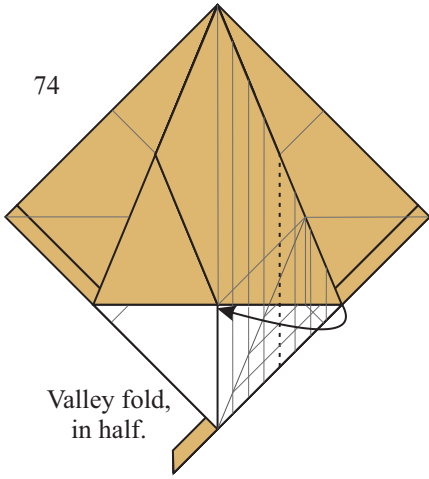

Valley fold, in half.

75

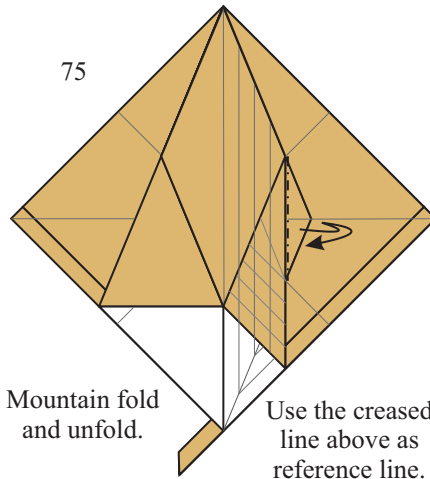

Mountain fold and unfold.

Use the creased line above as reference line.

76

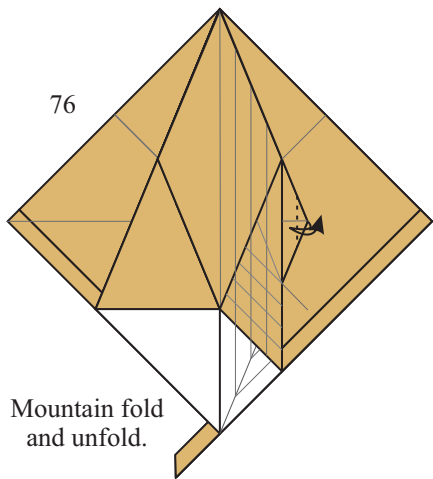

Mountain fold and unfold.

77

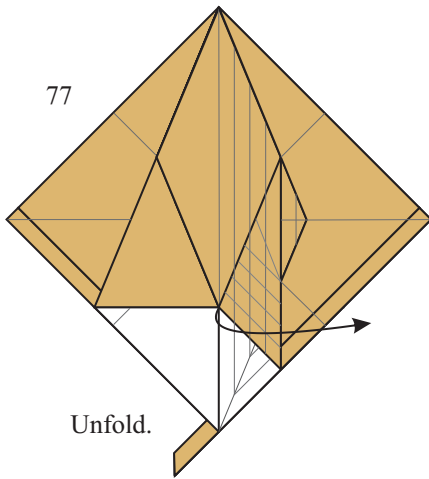

Unfold.

78

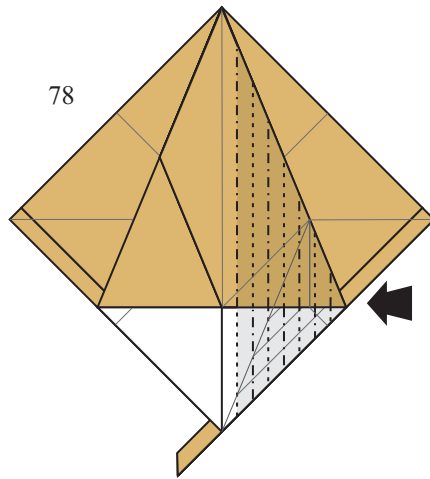

Inside reversed fold in and out

79

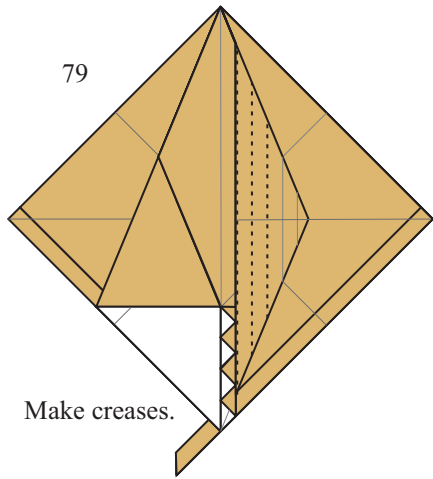

Make creases.

80

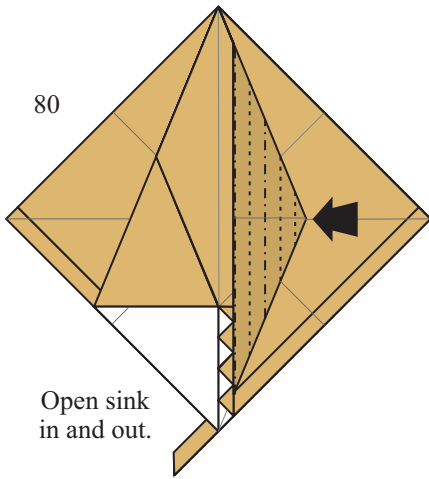

Open sink in and out.

81

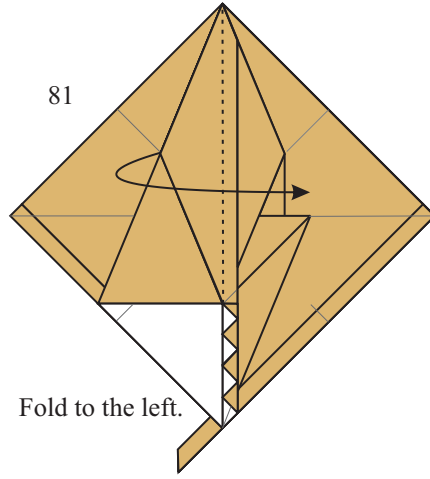

Fold to the left.

82

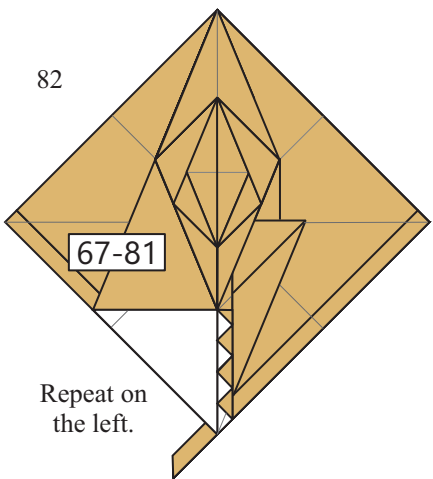

Repeat on the left.

83

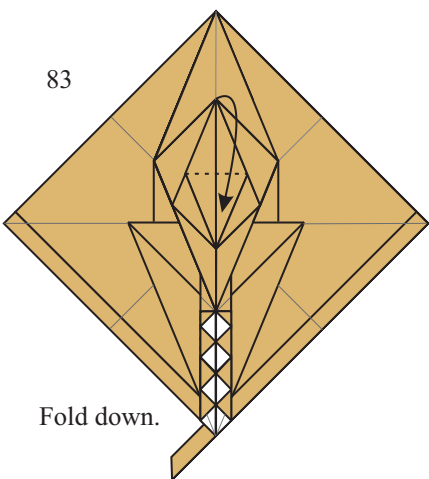

Fold down.

84

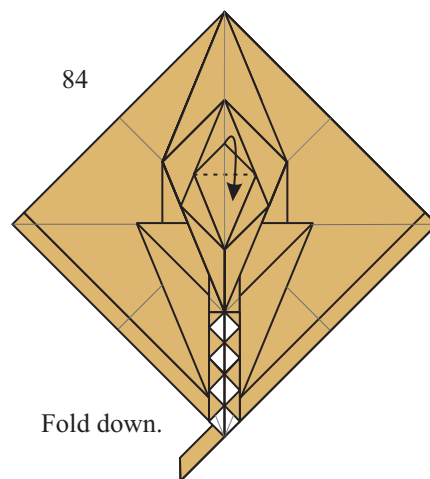

Fold down.

85

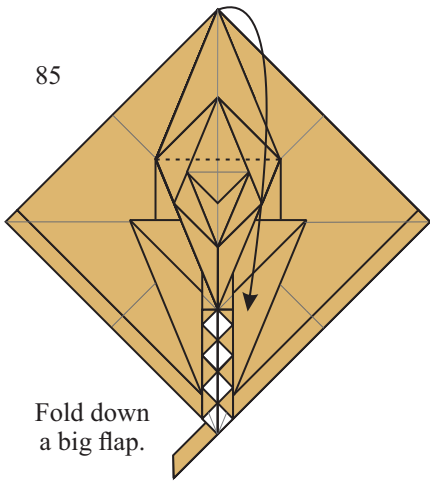

Fold down a big flap.

86

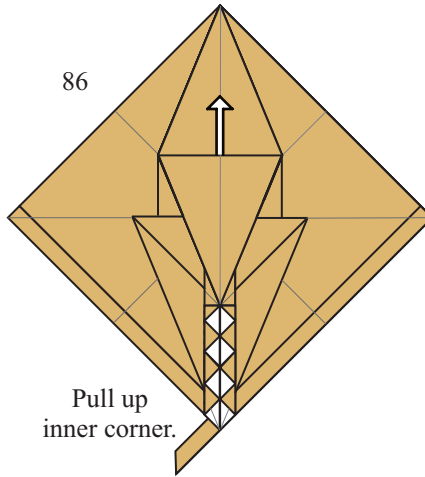

Pull up inner corner.

87

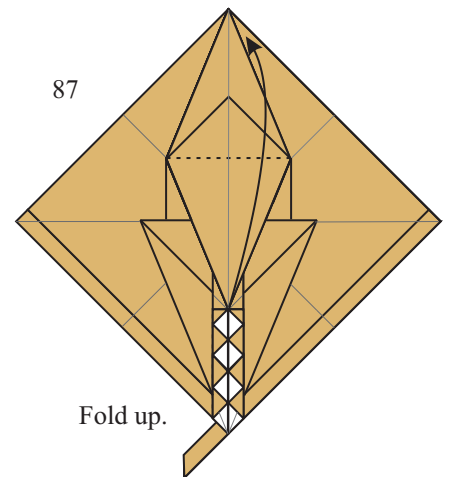

Fold up.

88

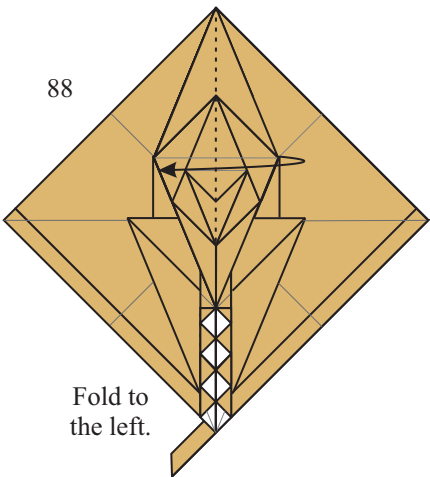

Fold to the left.

89

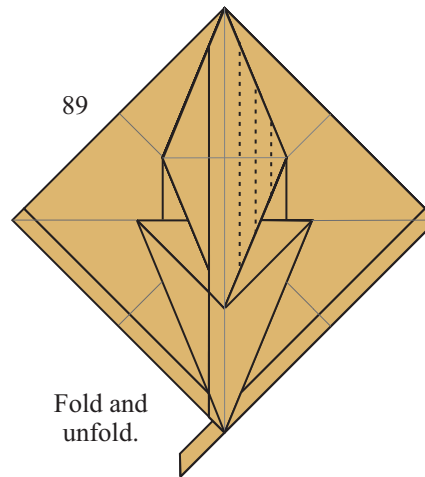

Fold and unfold.

90

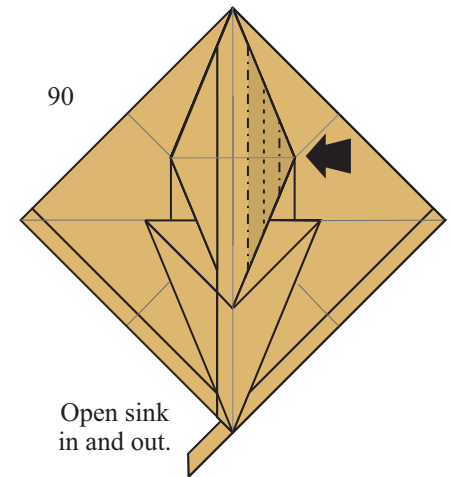

Open sink in and out.

91

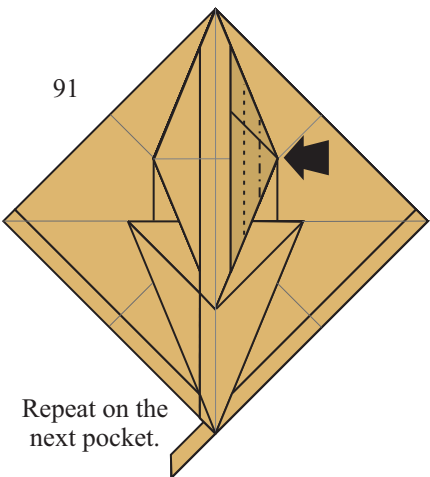

Repeat on the next pocket.

92

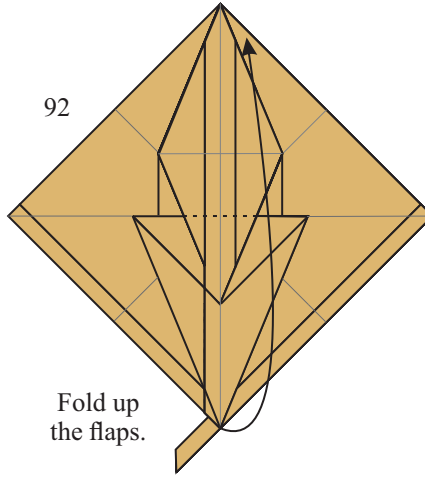

Fold up the flaps.

93

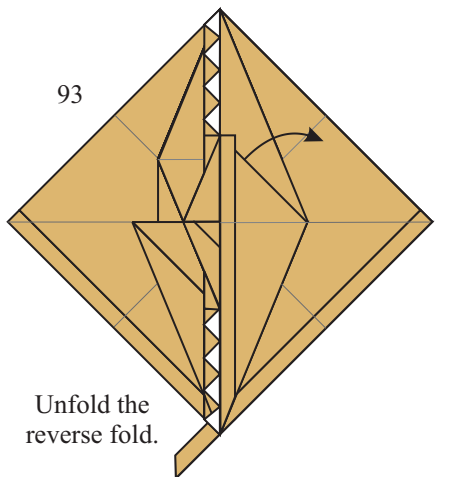

Unfold the reverse fold.

94

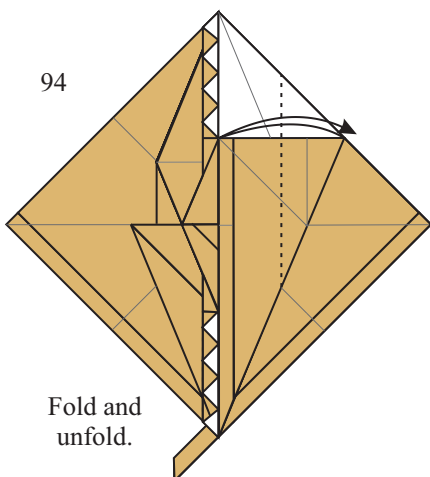

Fold and unfold.

95

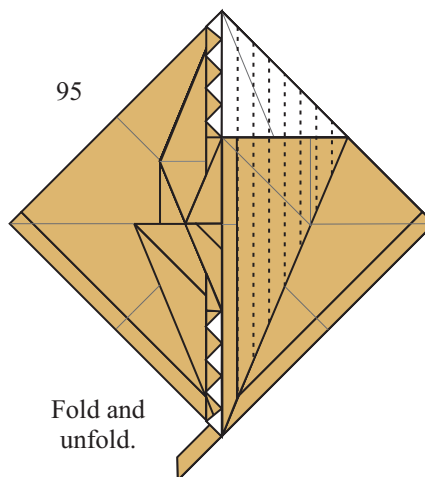

Fold and unfold.

96

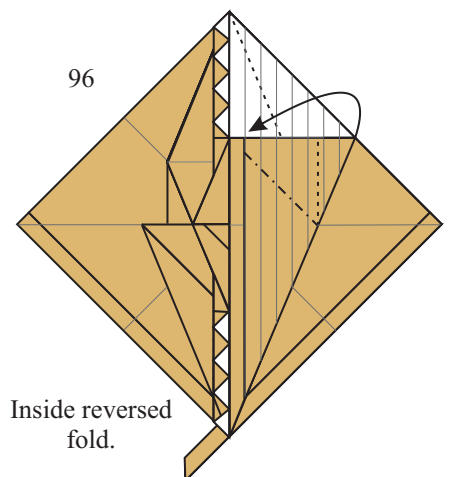

Inside reversed fold.

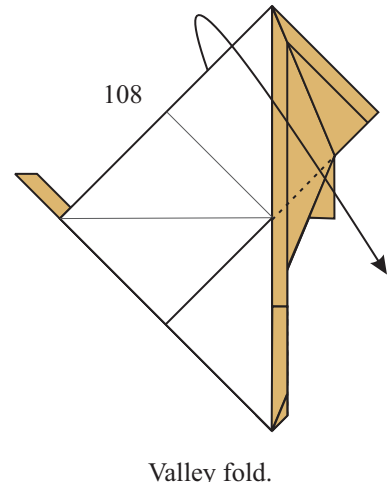
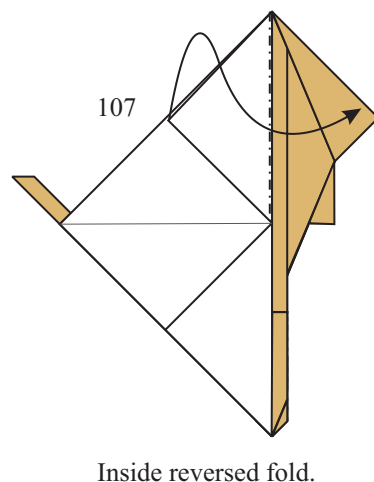
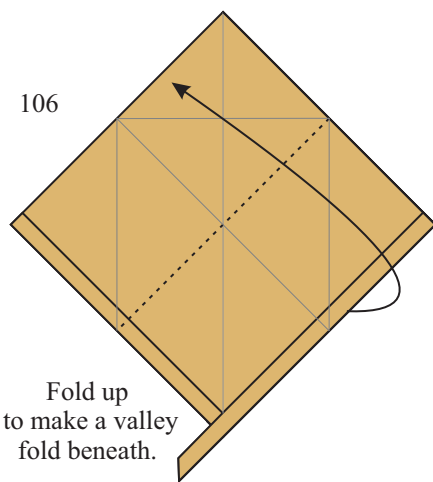
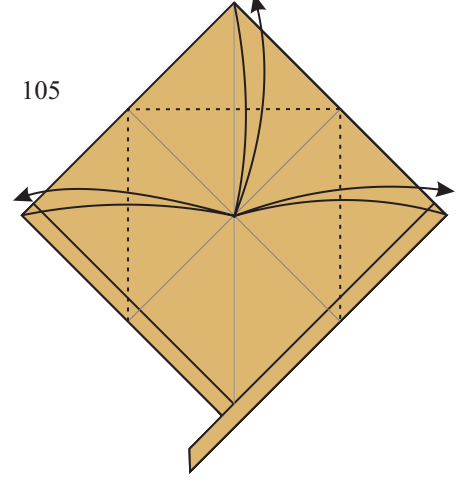
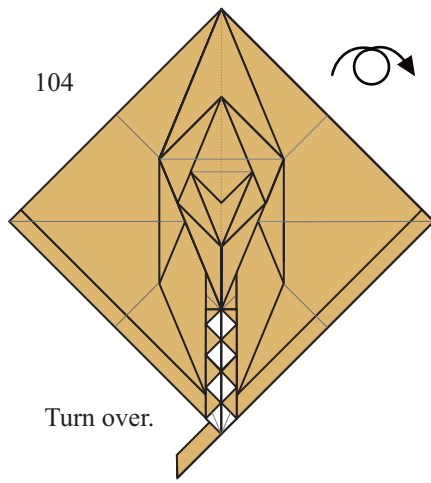
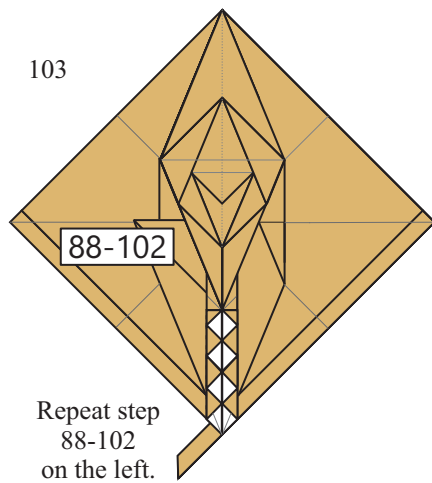
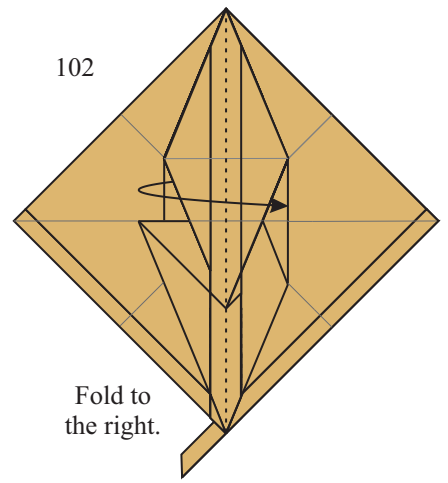
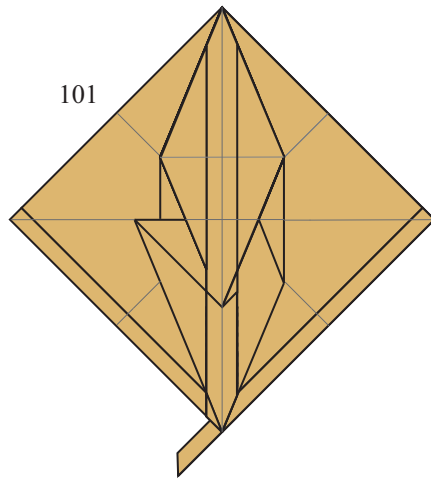
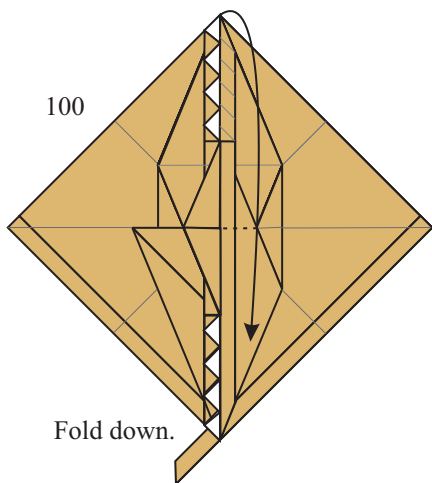
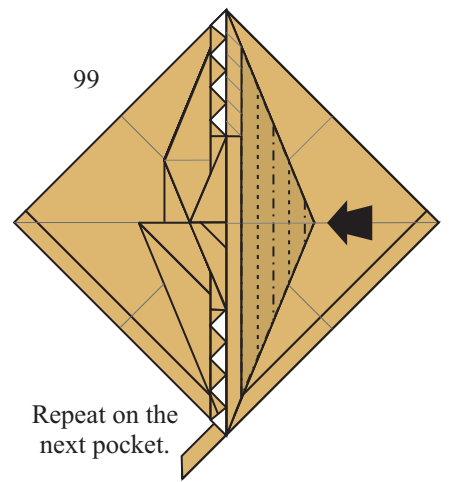
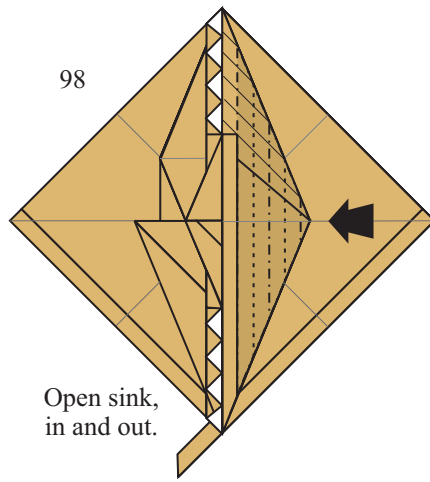
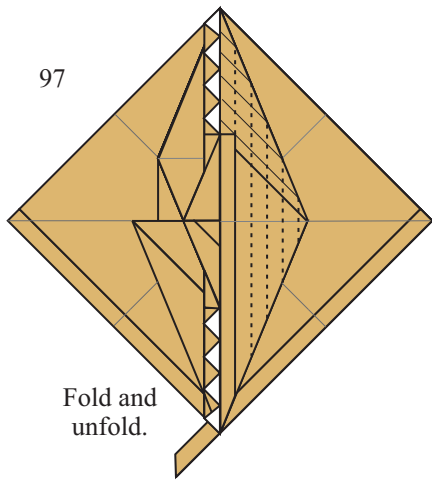

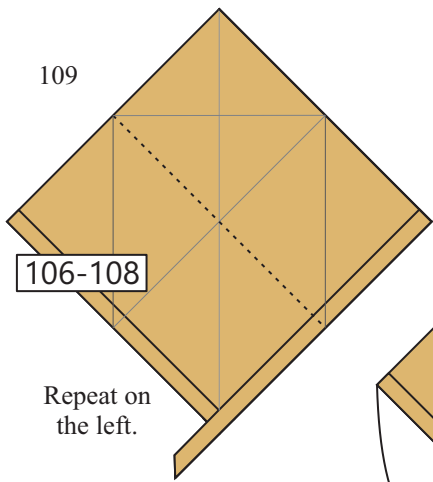

Repeat on the left.

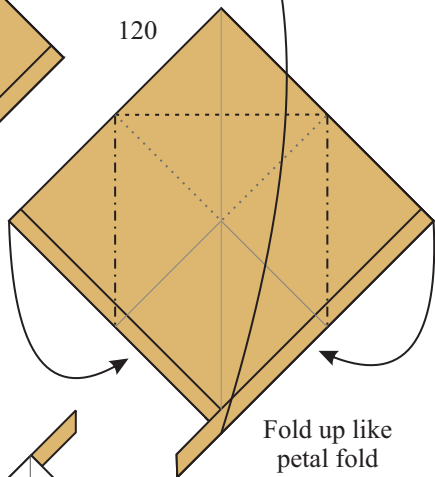

Fold up like petal fold but this one is box-pleating.

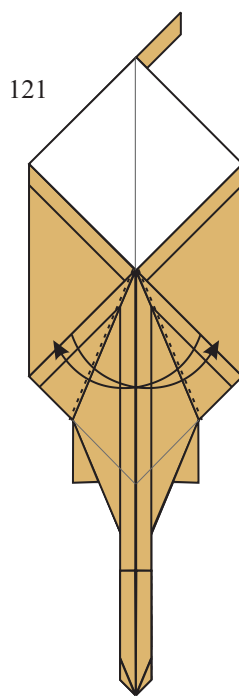

Fold and unfold.

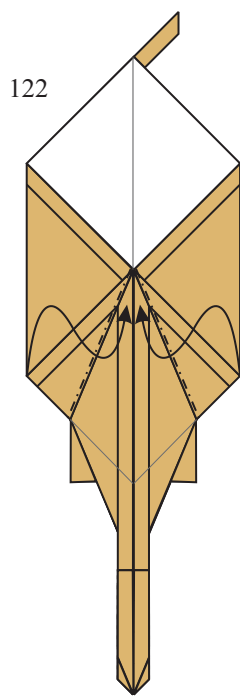

Inside reversed fold.

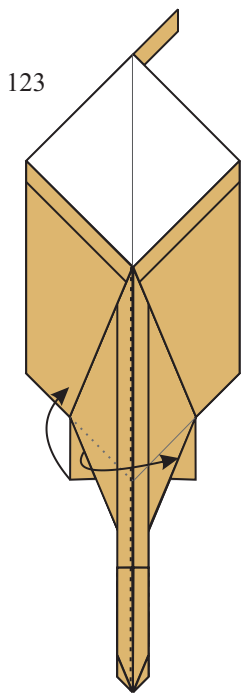

Fold to the right.

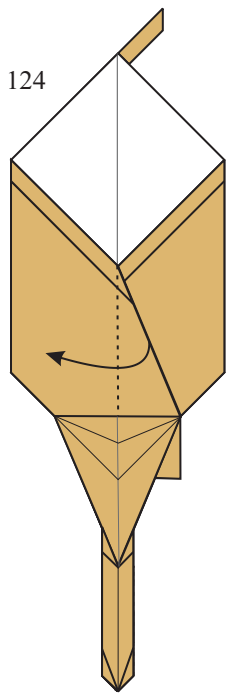

Fold the triangle to the left.

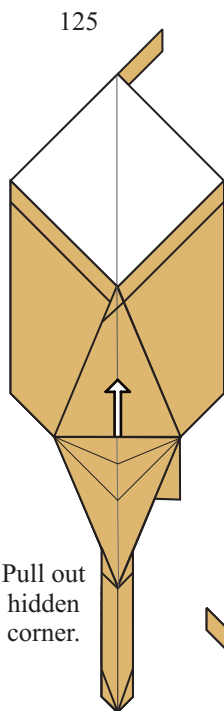

Pull out hidden corner.

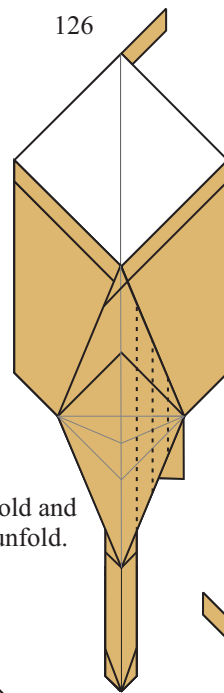

Fold and unfold.

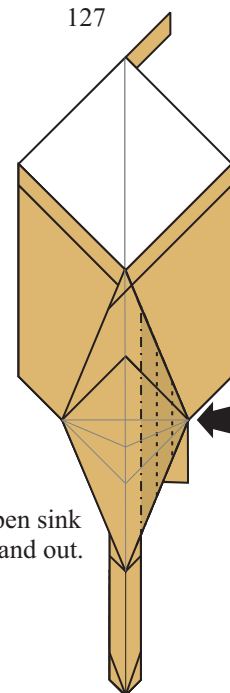

Open sink in and out.

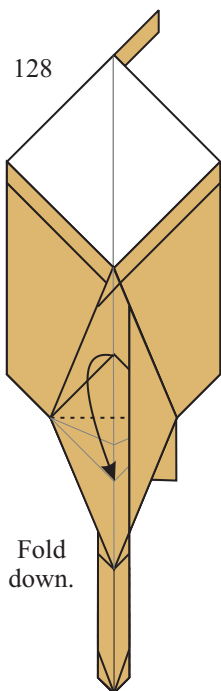

Fold down.

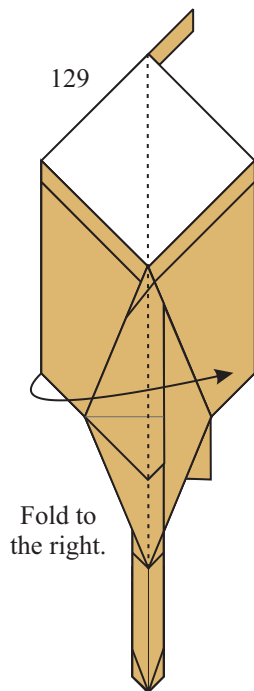

Fold to the right.

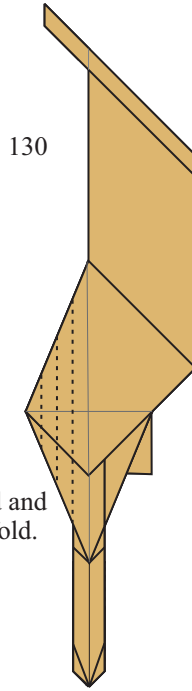

Fold and unfold.

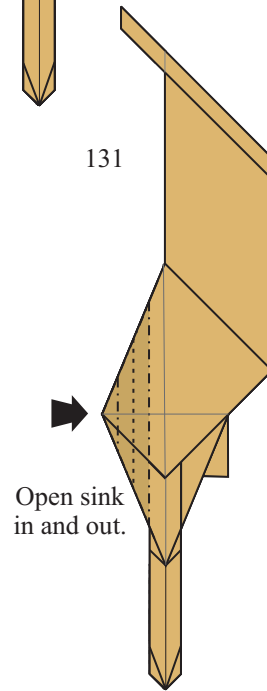

Open sink in and out.

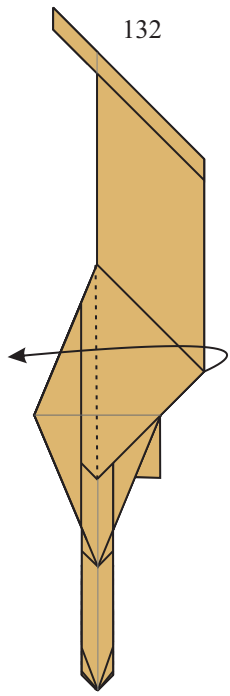

132
Fold to the left.

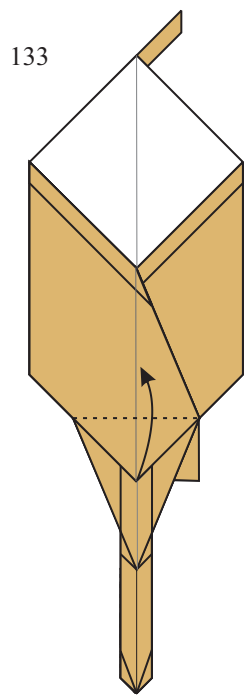

133
Fold up.

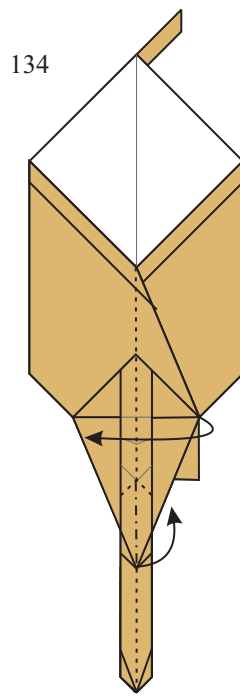

134
Fold in half and right up the middle flap.

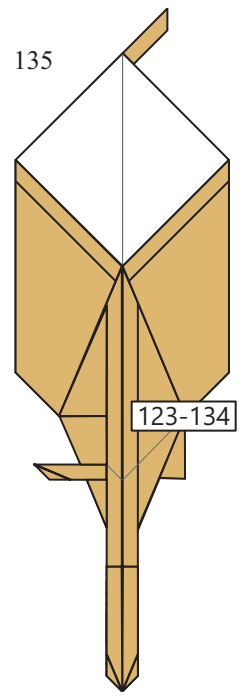

135
Repeat on the right.

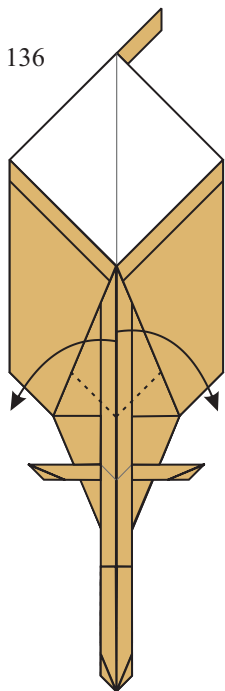

136
Valley fold.

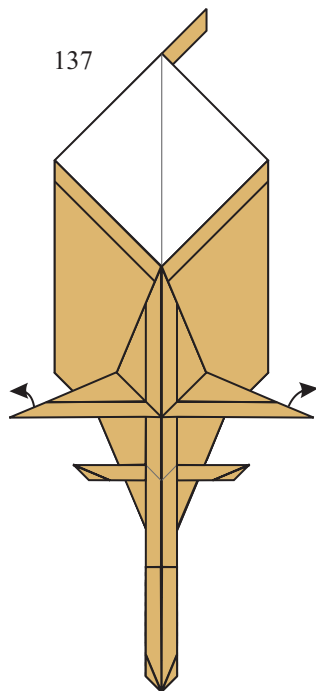

137
Pull out hidden layers.

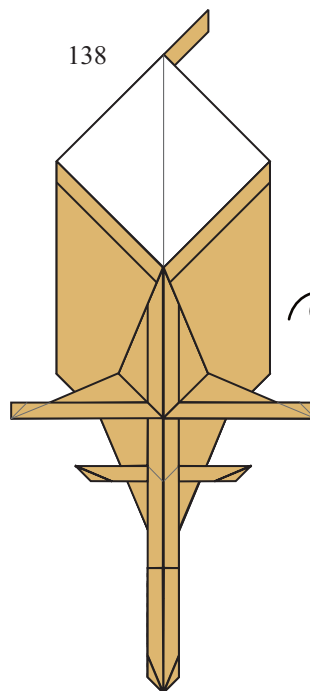

138
Turn over.

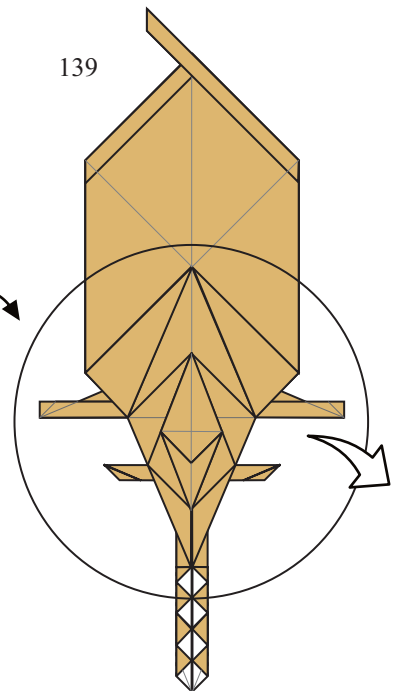

139
Zoom in.

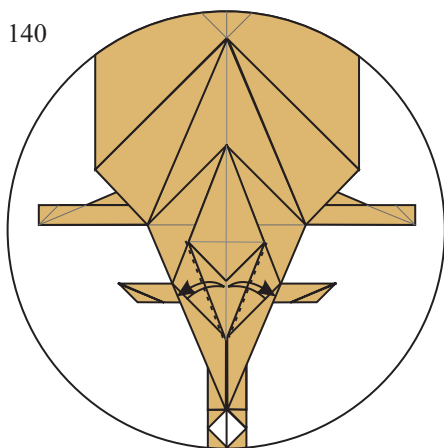

140
Fold and unfold.

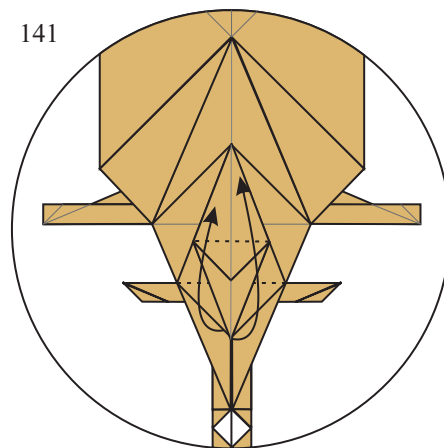

141
Fold up 2 flaps.

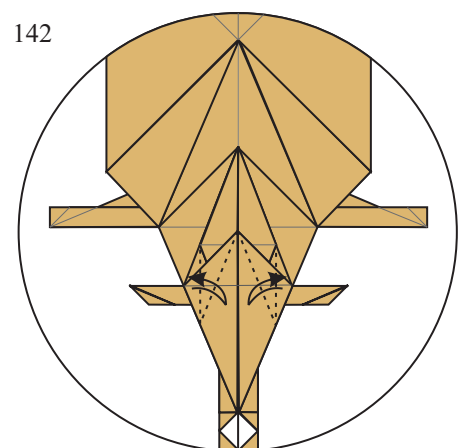

142
Fold and unfold.

143

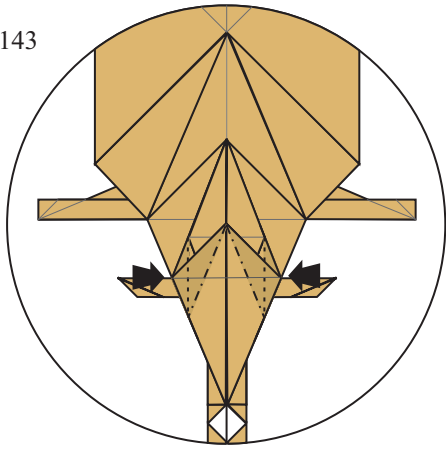

Open sink.

144

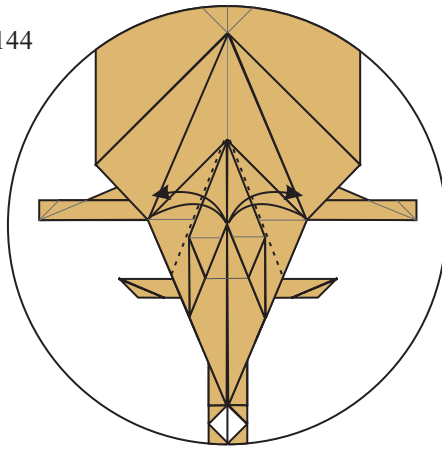

Fold and unfold.

145

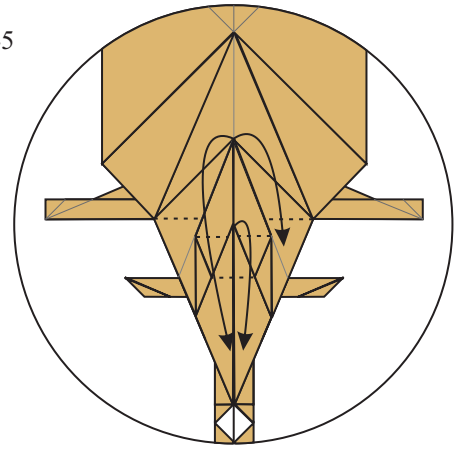

Fold down 3 flaps.

146

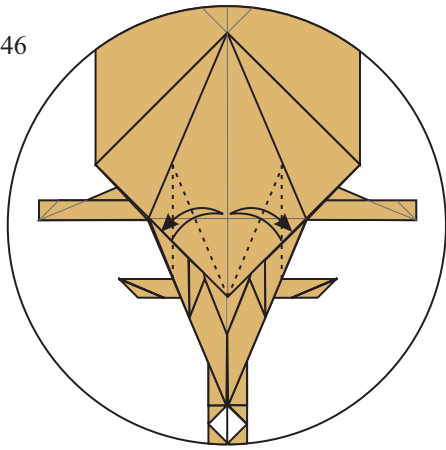

Fold and unfold.

147

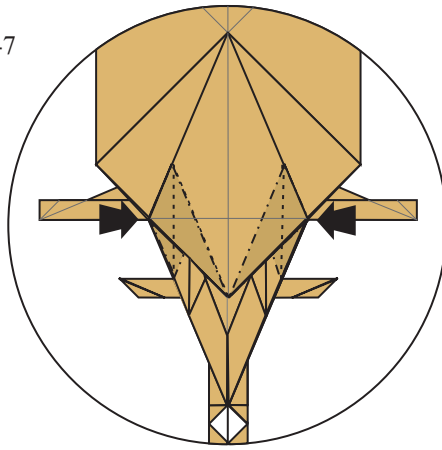

Open sink.

148

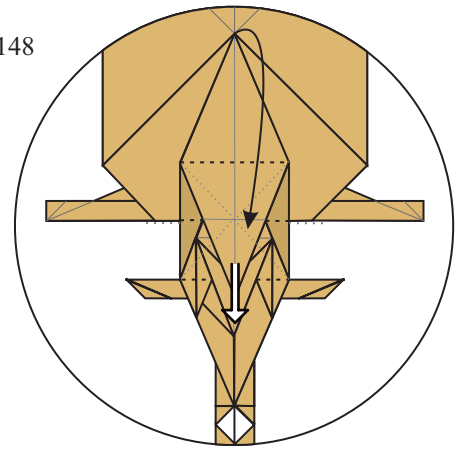

Pull the middle flap down...

149

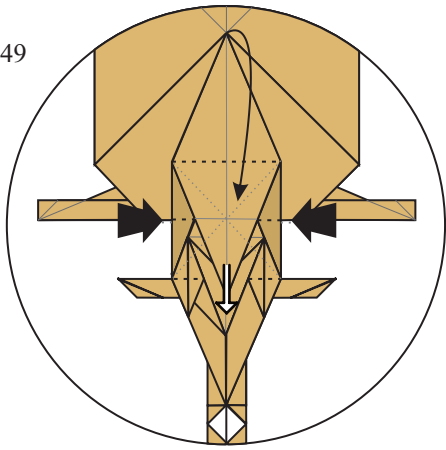

... by pushing the middle pocket.
This changes the 22.5 degree structure.

150

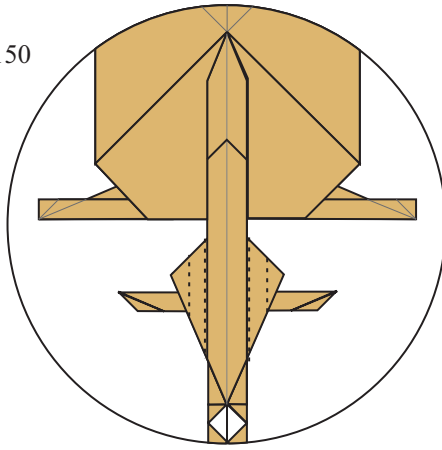

Fold and unfold.

151

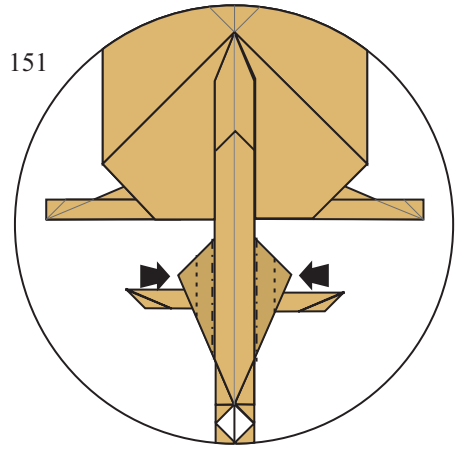

Open sink, in and out.

152

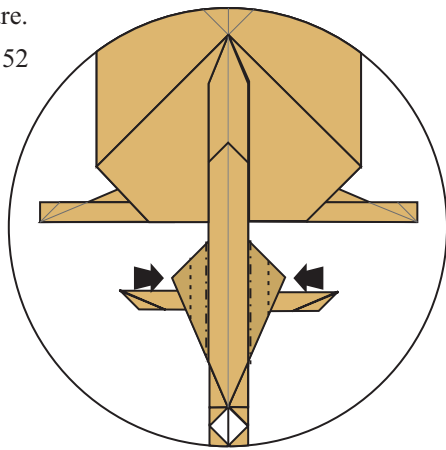

Repeat on the next pocket.

153

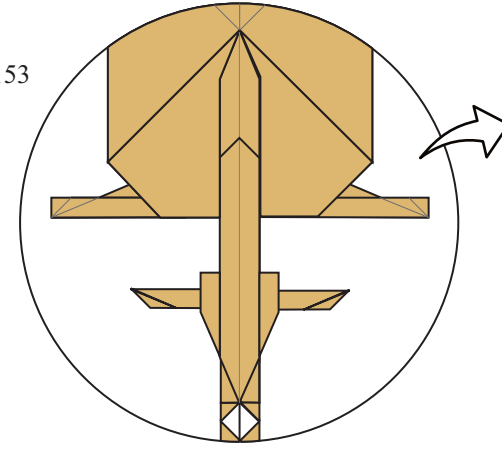

Zoom out.

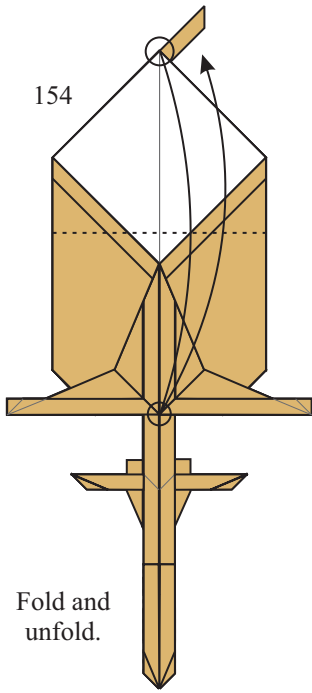

154
Fold and unfold.

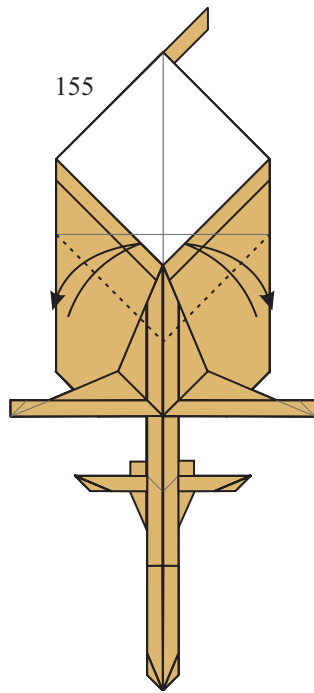

155
Fold and unfold.

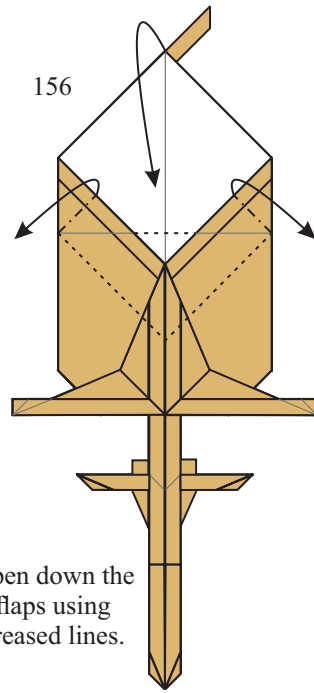

156
Open down the flaps using creased lines.

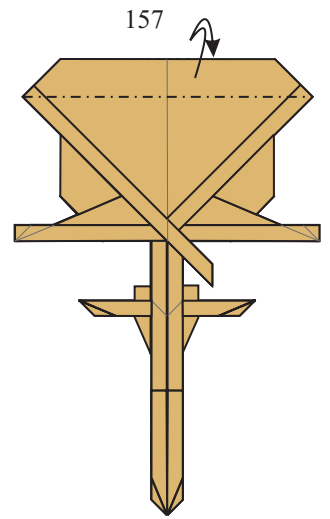

157
Mountain fold and unfold.

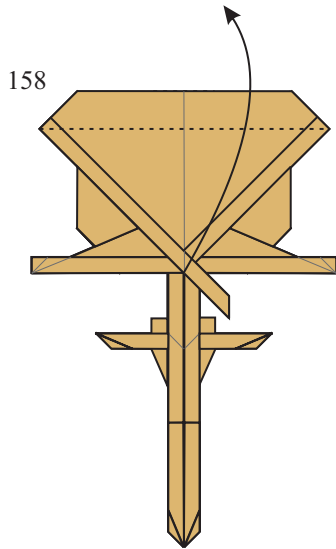

158
Valley fold.

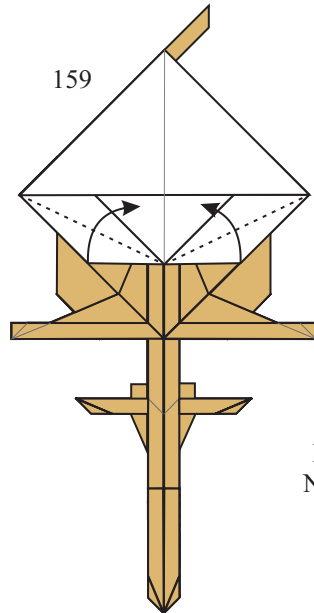

159
Valley fold.

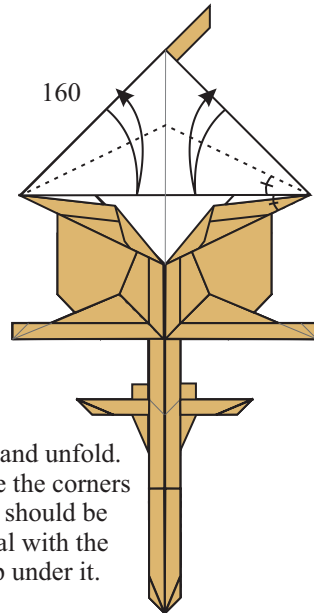

160
Fold and unfold. Notice the corners that should be equal with the flap under it.

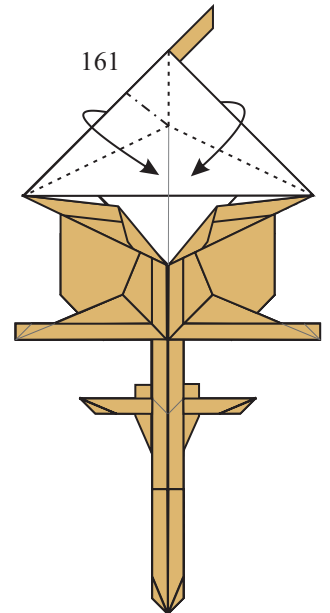

161
Rabbit-ear fold.

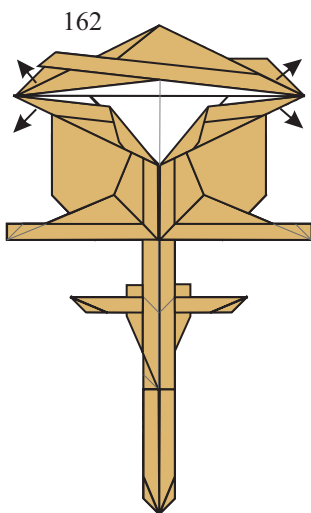

162
Pull out folded 2 layers.

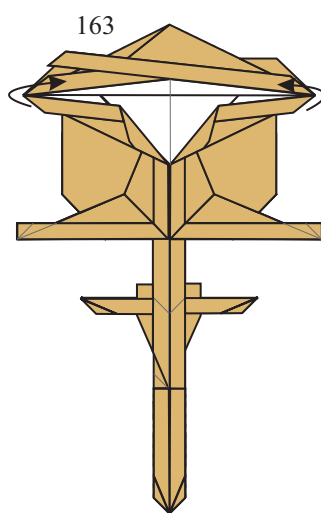

163
Peel the behind layers to the front.

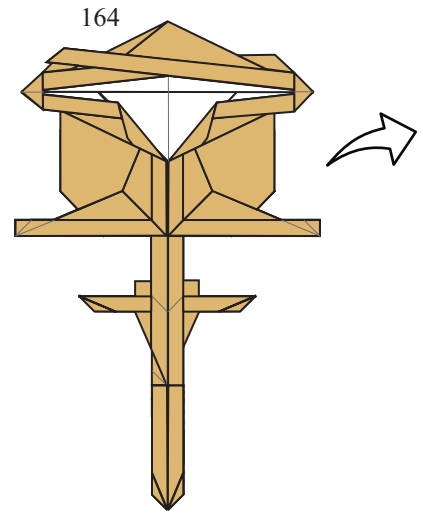

164
Zoom in.

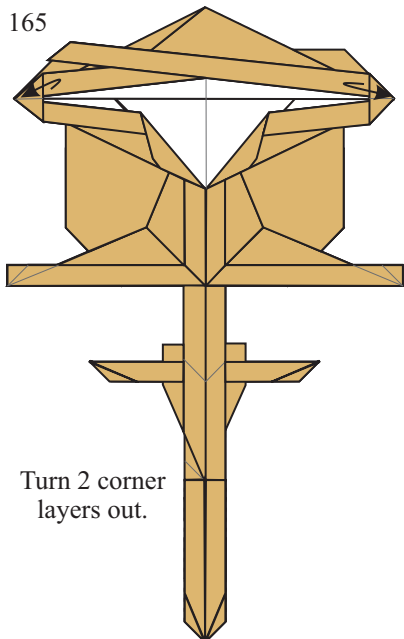

Turn 2 corner layers out.

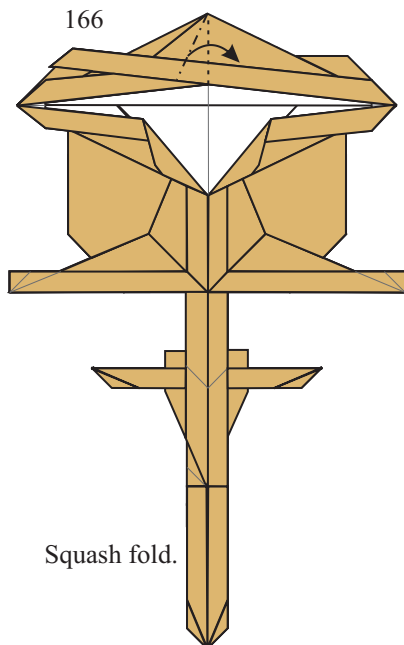

Squash fold.

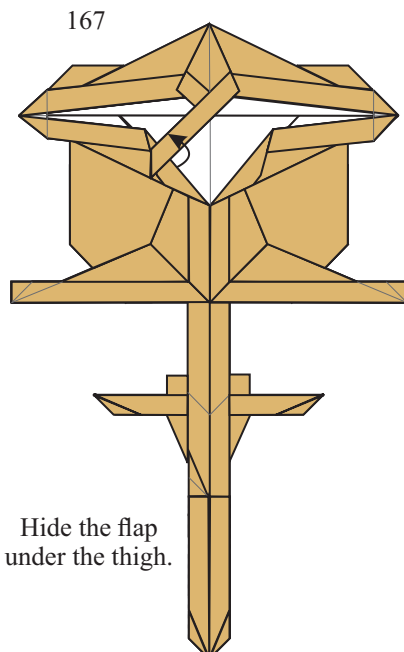

Hide the flap under the thigh.

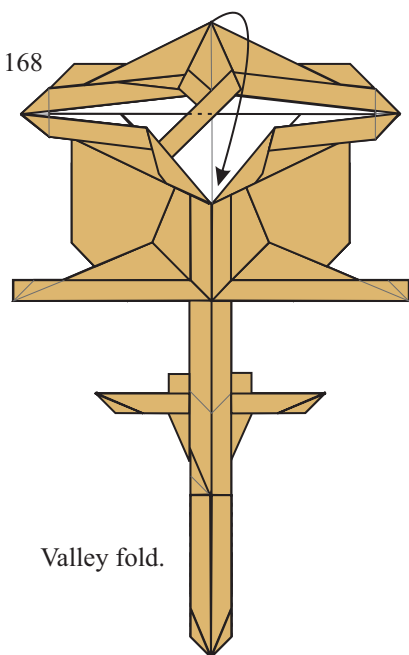

Valley fold.

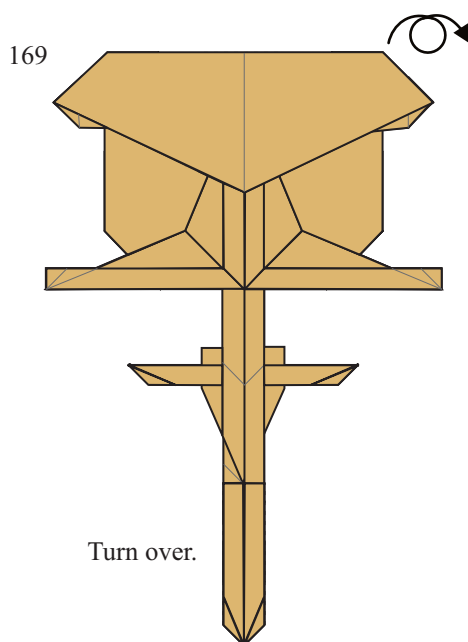

Turn over.

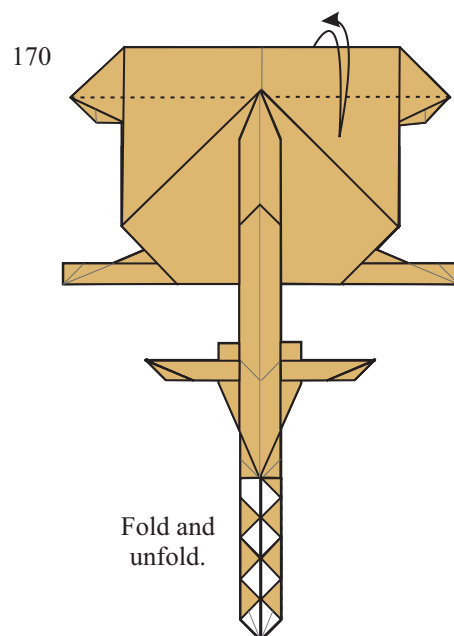

Fold and unfold.

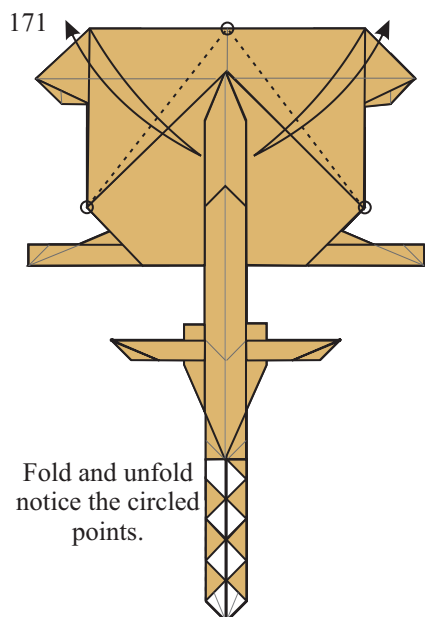

Fold and unfold notice the circled points.

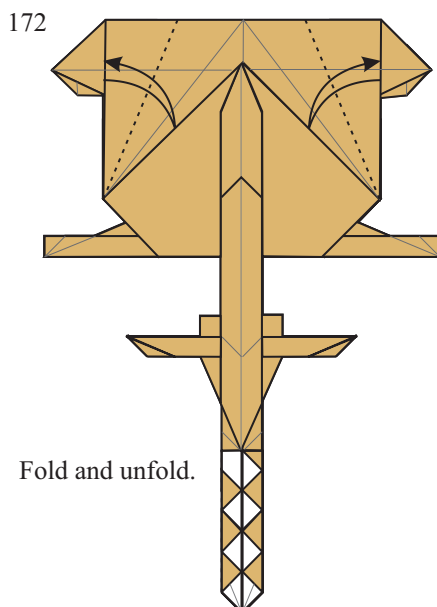

Fold and unfold.

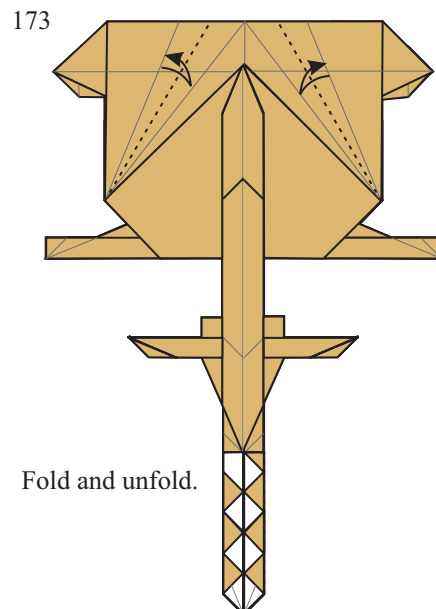

Fold and unfold.

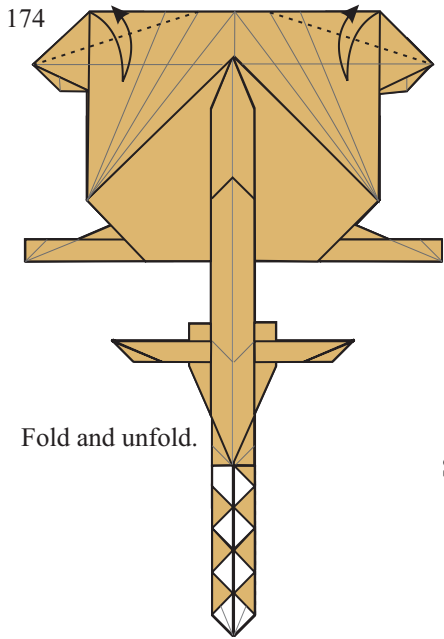

Fold and unfold.

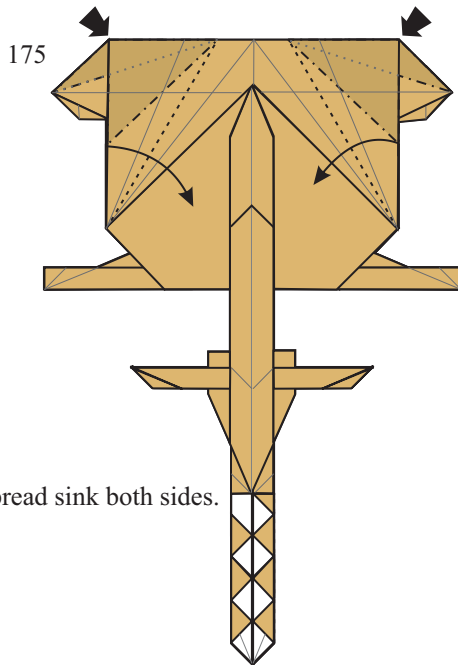

Spread sink both sides.

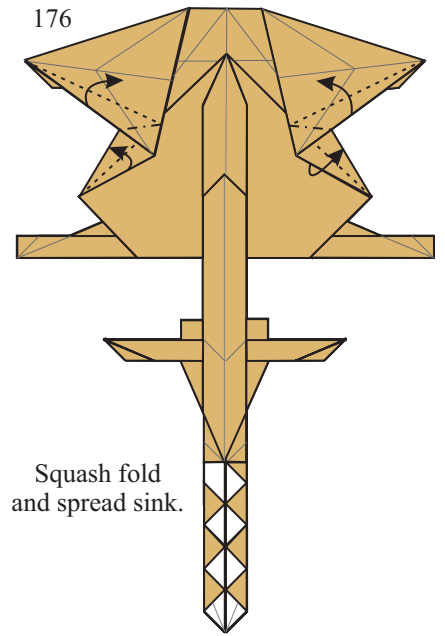

Squash fold and spread sink.

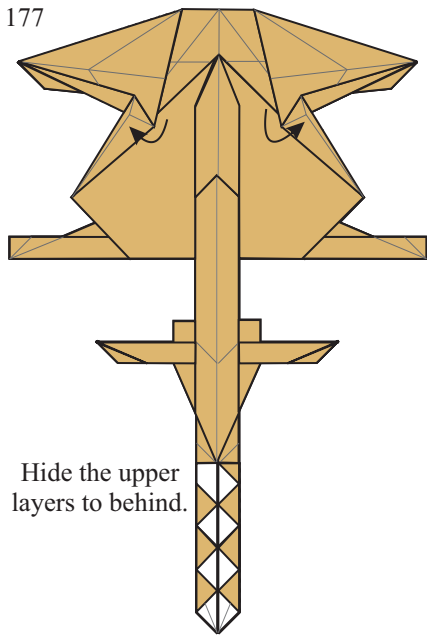

Hide the upper layers to behind.

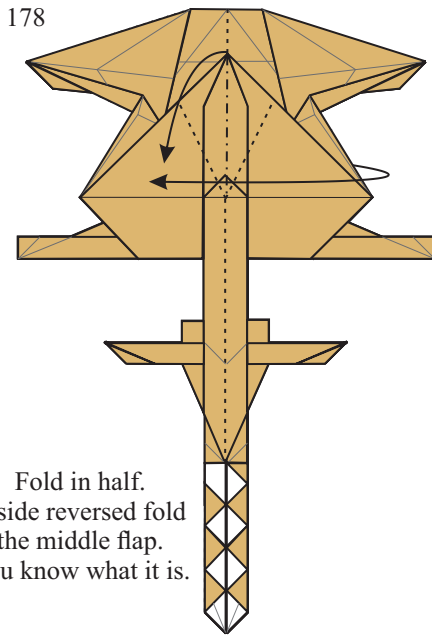

Fold in half.
Inside reversed fold the middle flap.
You know what it is.

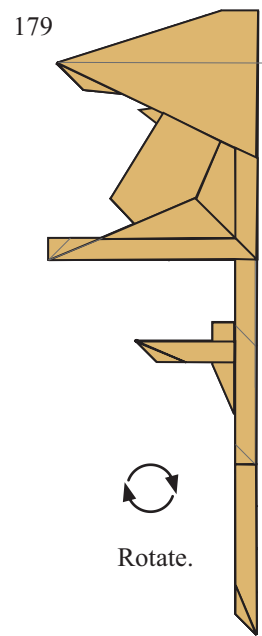

Rotate.

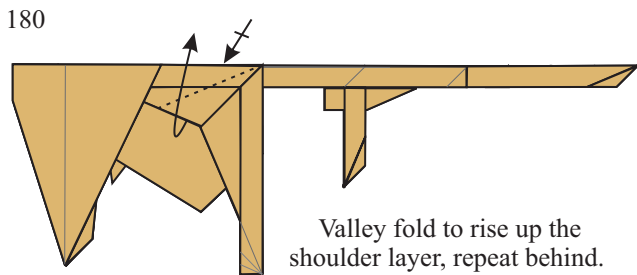

Valley fold to rise up the shoulder layer, repeat behind.

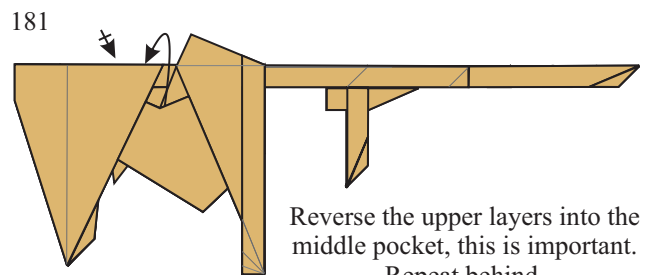

Reverse the upper layers into the middle pocket, this is important. Repeat behind.

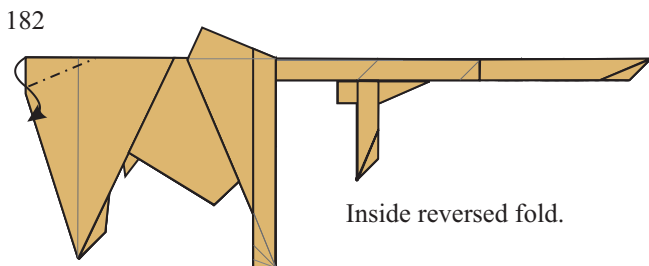

Inside reversed fold.

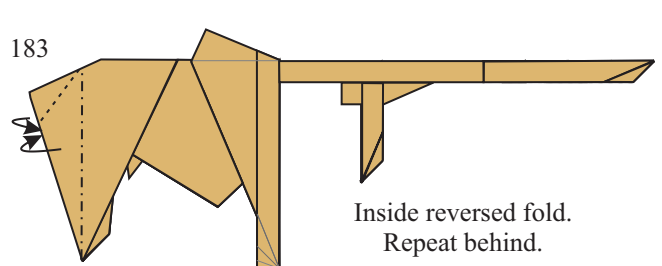

Inside reversed fold. Repeat behind.

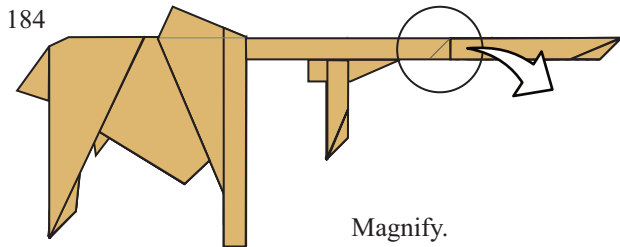

Magnify.

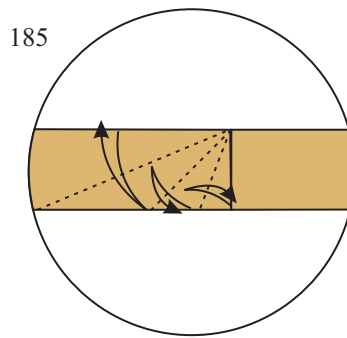

Fold and unfold.

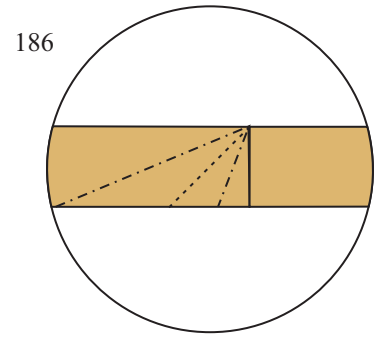

Inside reversed fold in and out.

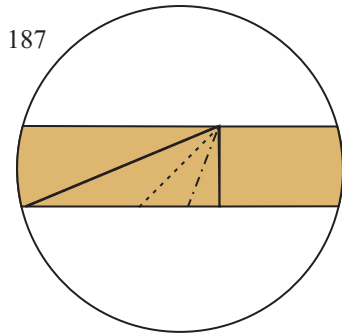

Repeat on the next pocket.

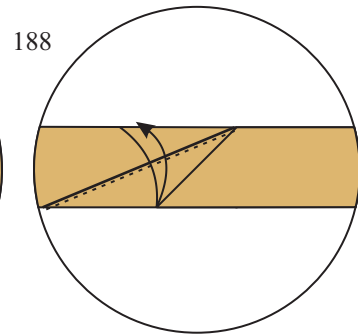

Fold and unfold.

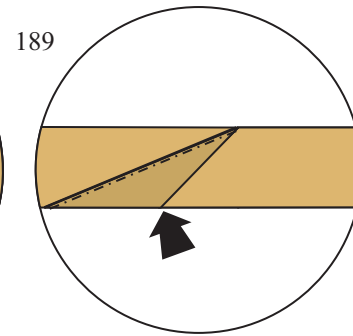

Open sink.

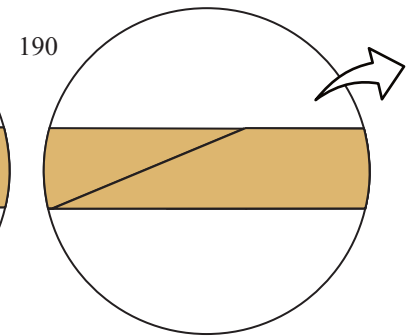

Zoom out.

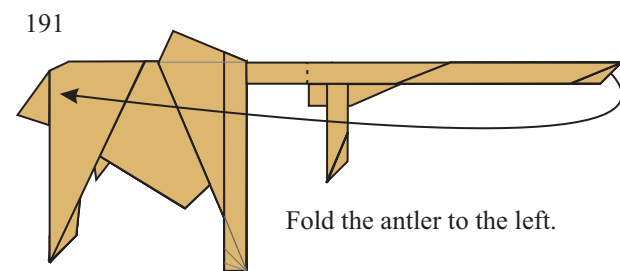

Fold the antler to the left.

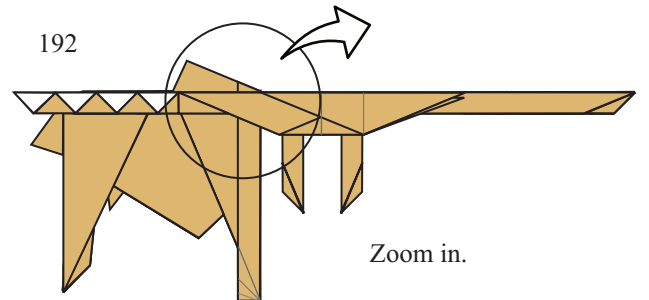

Zoom in.

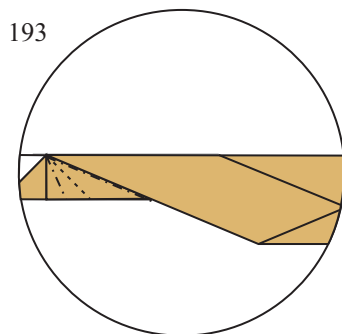

Inside reverse fold in and out. Just on the first pocket.

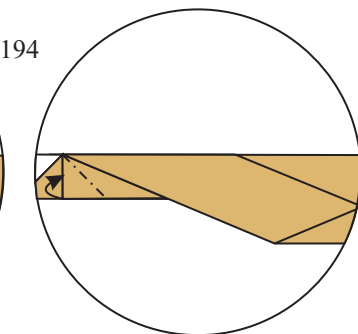

Inside reversed fold.

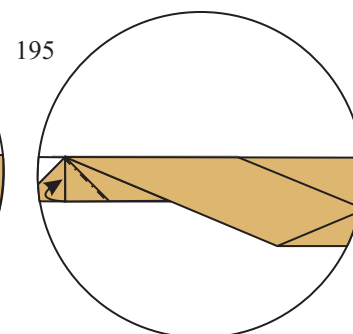

Inside reversed fold.

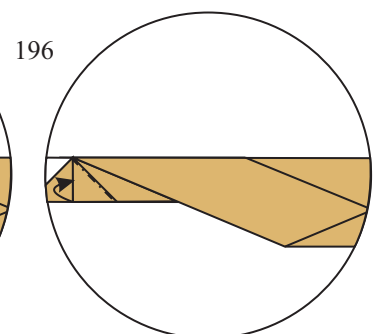

Inside reversed fold.

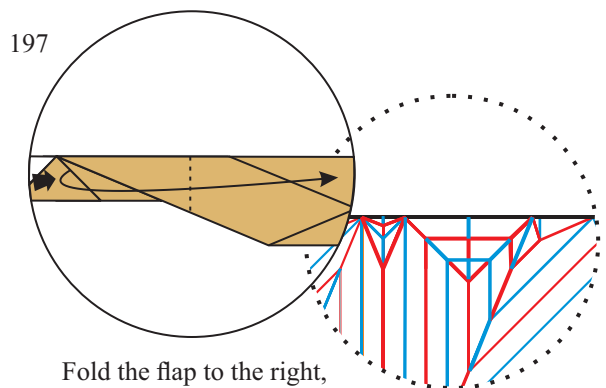

Fold the flap to the right, as far as the box-pleating allows you. Look at the crease pattern to make this step.

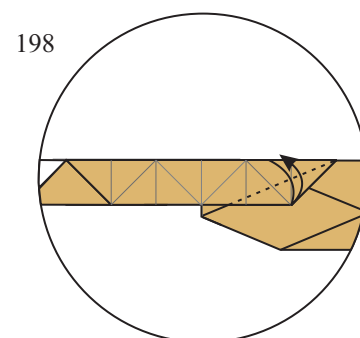

The result should be like this. Fold and unfold.

199

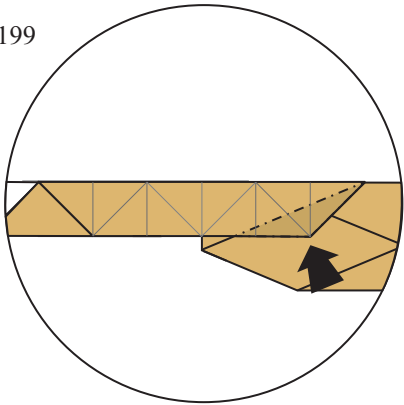

Open sink.

200

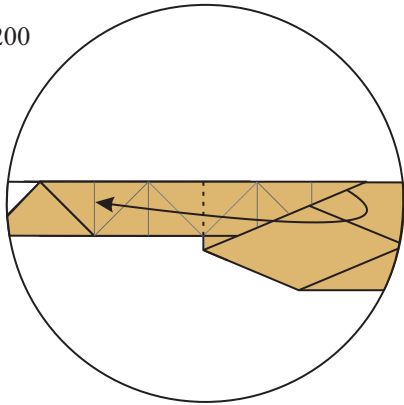

Fold to the left.

201

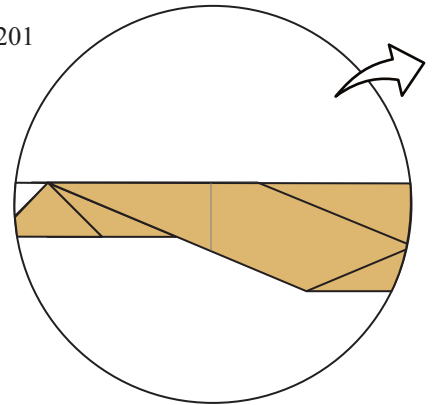

Zoom out.

202

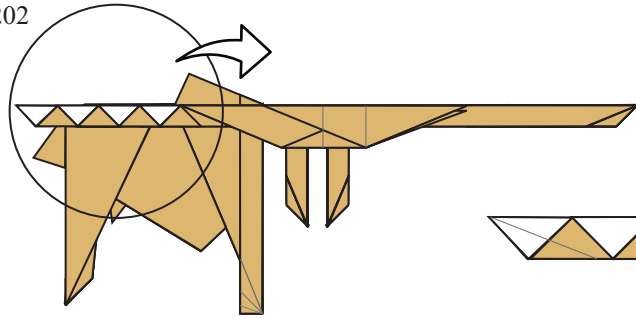

Zoom in.

203

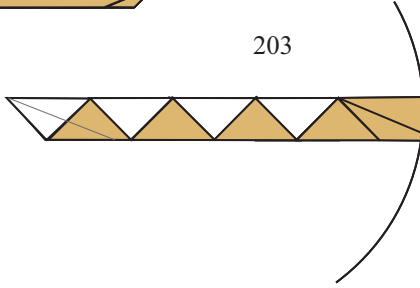

204

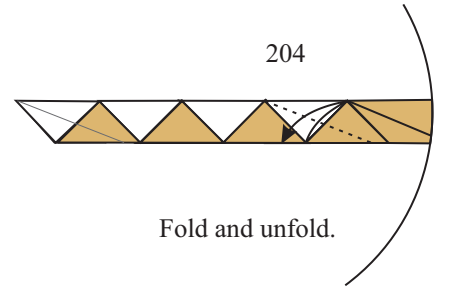

Fold and unfold.

205

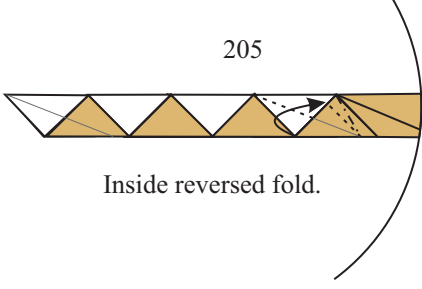

Inside reversed fold.

206

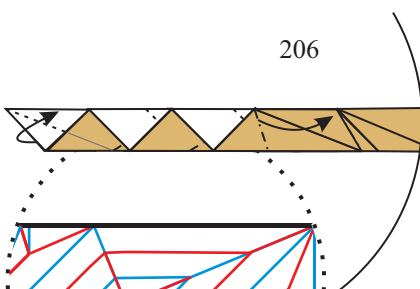

Fold and unfold.

207

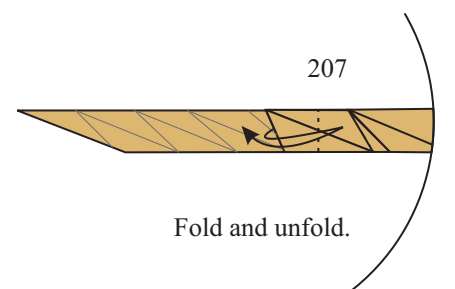

Collapse the diagonal box-pleat. As show on the crease pattern.

208

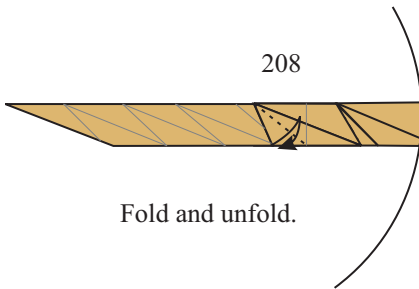

Fold and unfold.

209

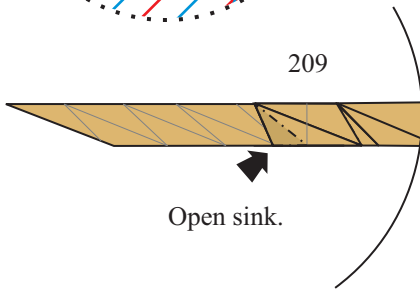

Open sink.

210

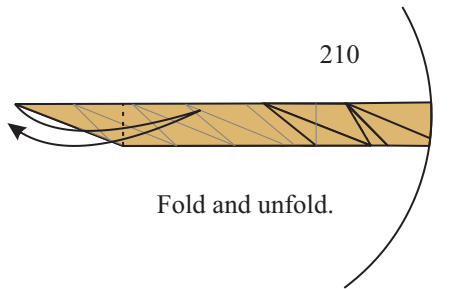

Fold and unfold.

211

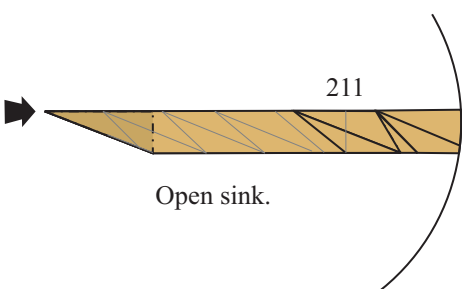

Open sink.

212

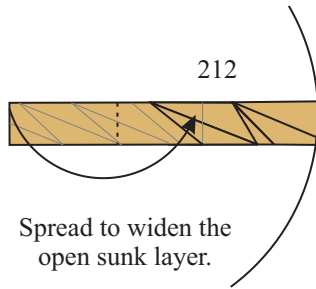

Spread to widen the open sunk layer.

213

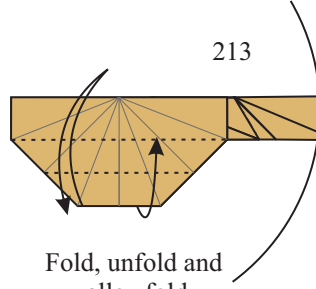

Fold, unfold and valley fold.

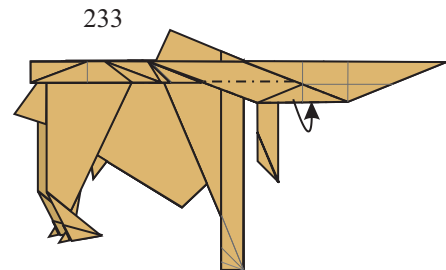
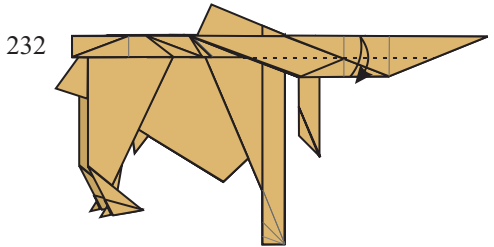
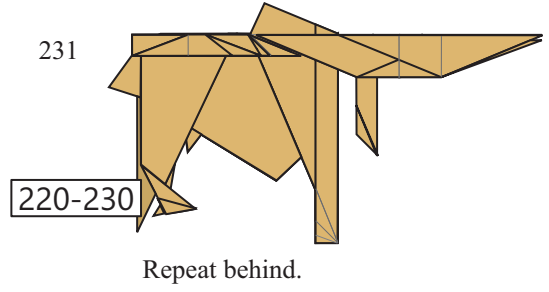
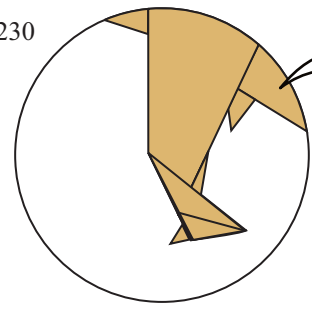
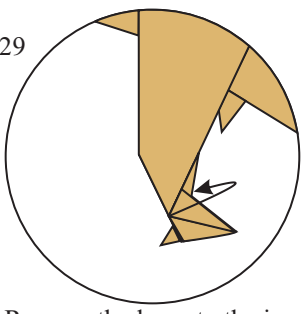
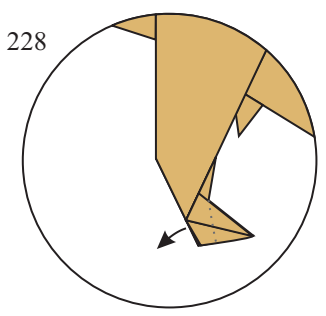
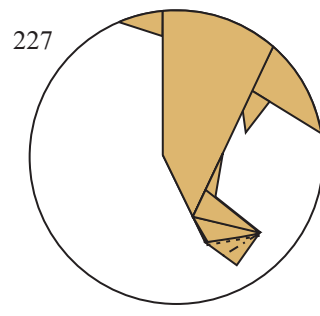
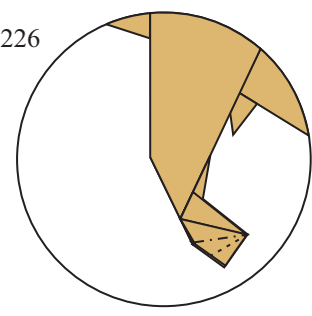
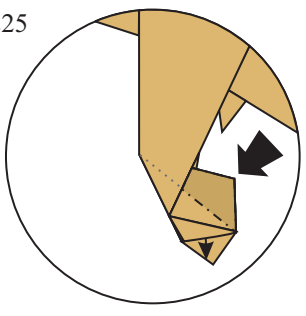
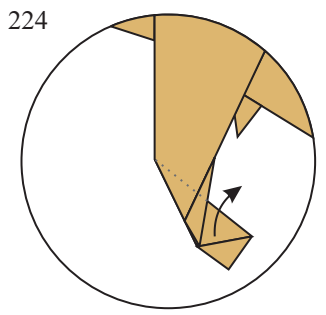
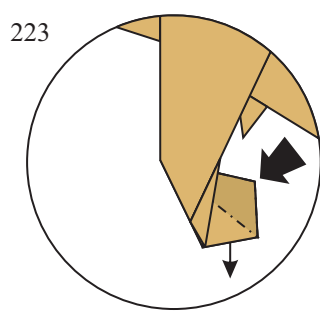
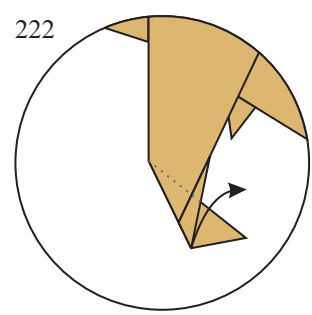
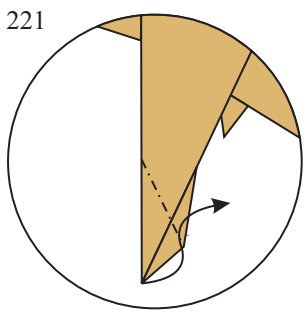
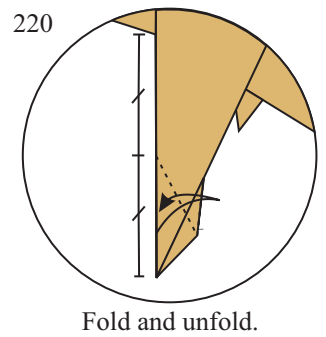
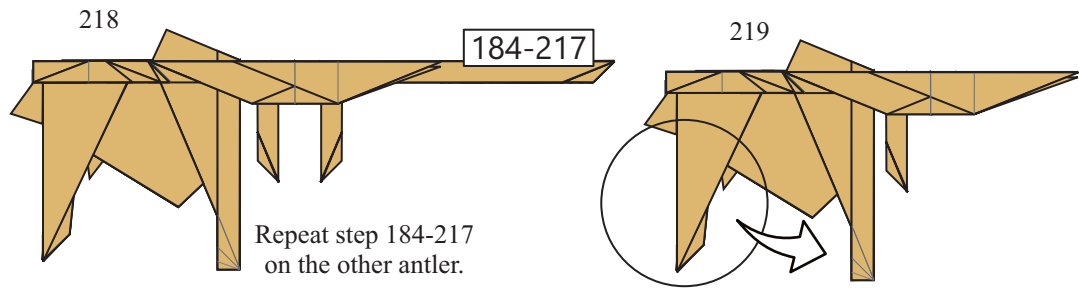
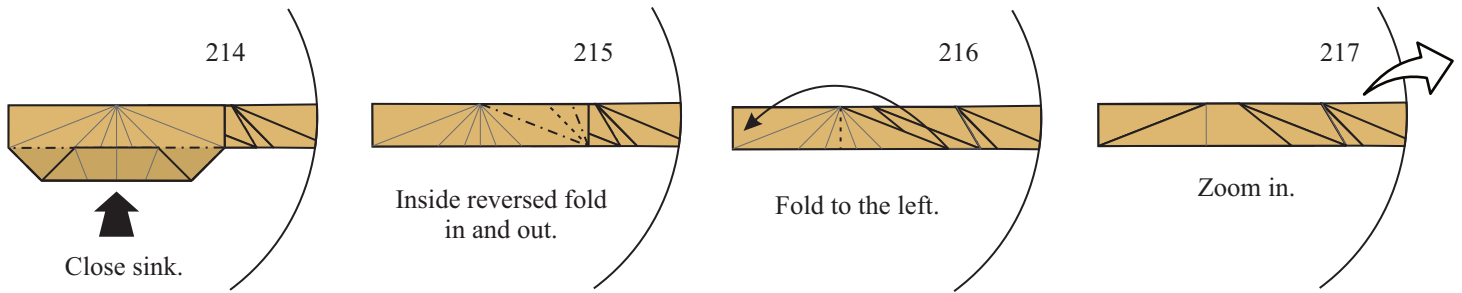

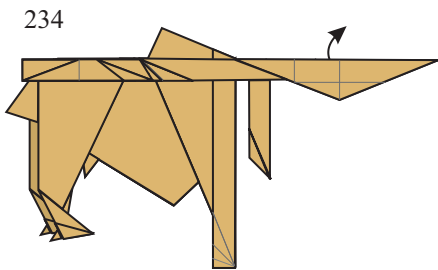

234 Rise up the flap behind.

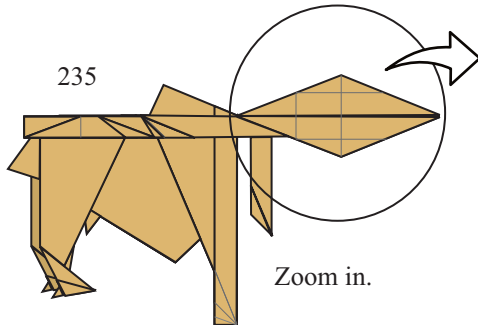

235 Zoom in.

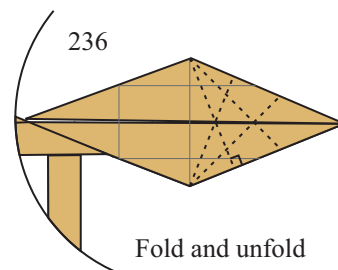

236 Fold and unfold

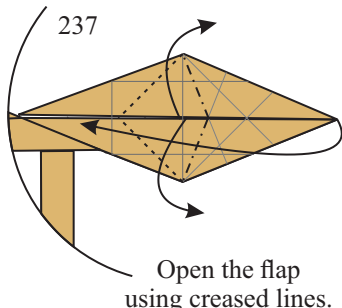

237 Open the flap using creased lines.

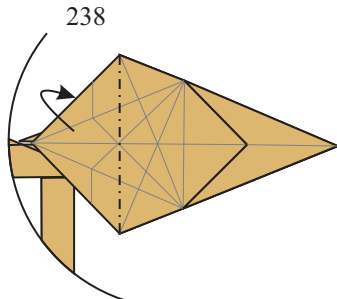

238 Mountain fold.

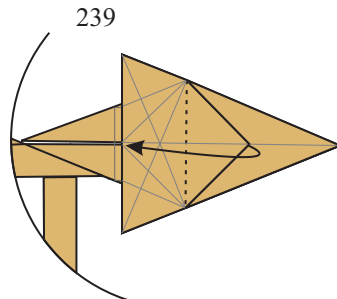

239 Fold to the left.

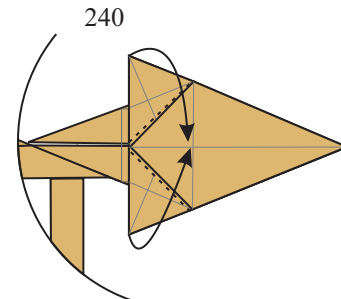

240 Valley fold.

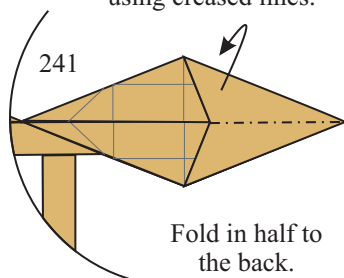

241 Fold in half to the back.

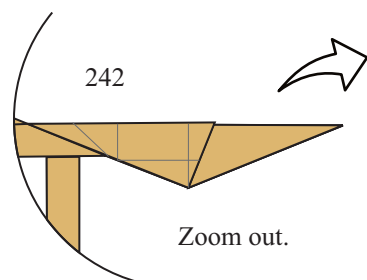

242 Zoom out.

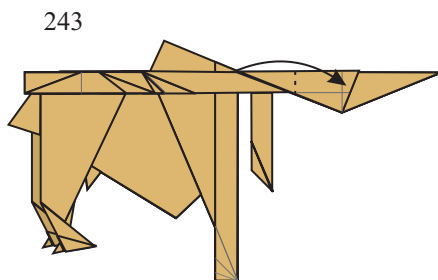

243 Fold the ear to the right.

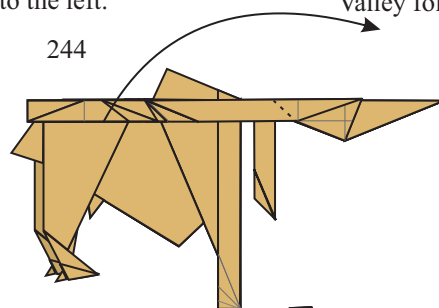

244 Valley fold the antler up.

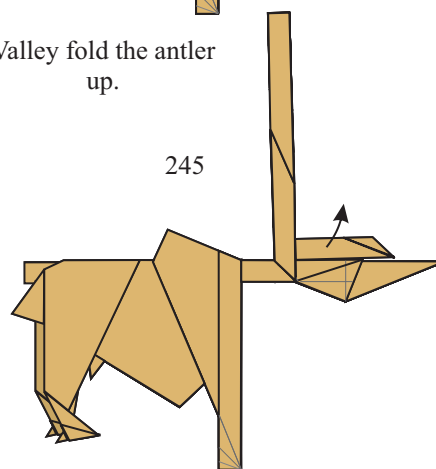

245 Pull out a layer.

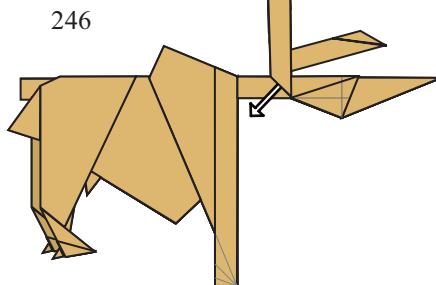

246 Fold the layer up.

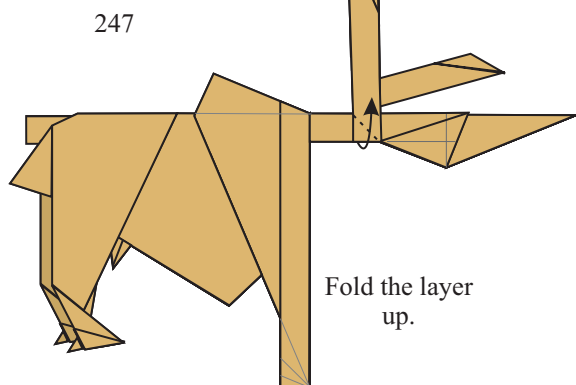

247 Fold the layer up.

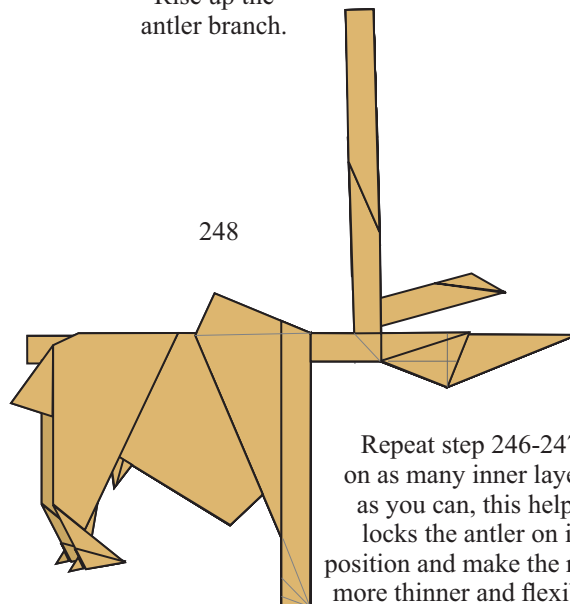

248

Repeat step 246-247 on as many inner layers as you can, this helps lock the antler on its position and make the neck more thinner and flexible.

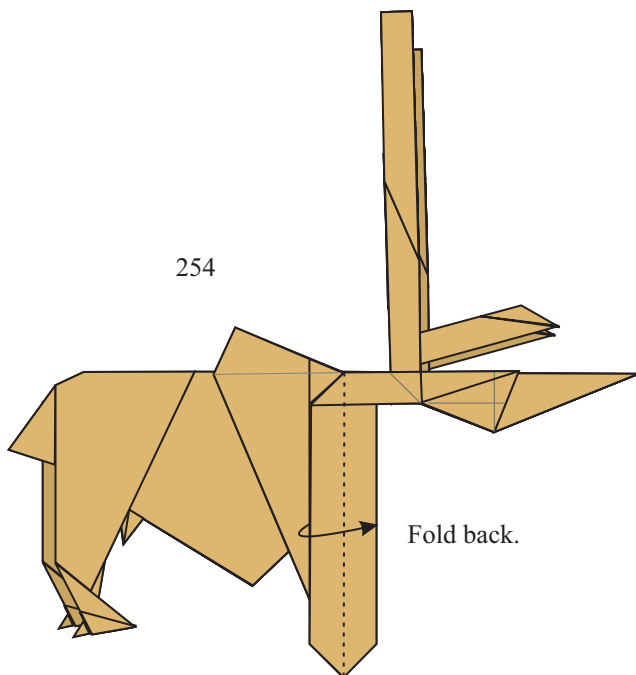
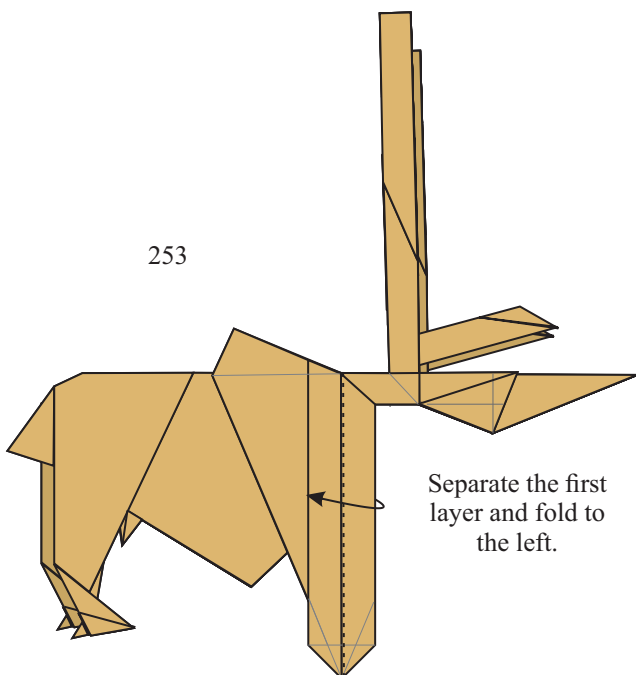
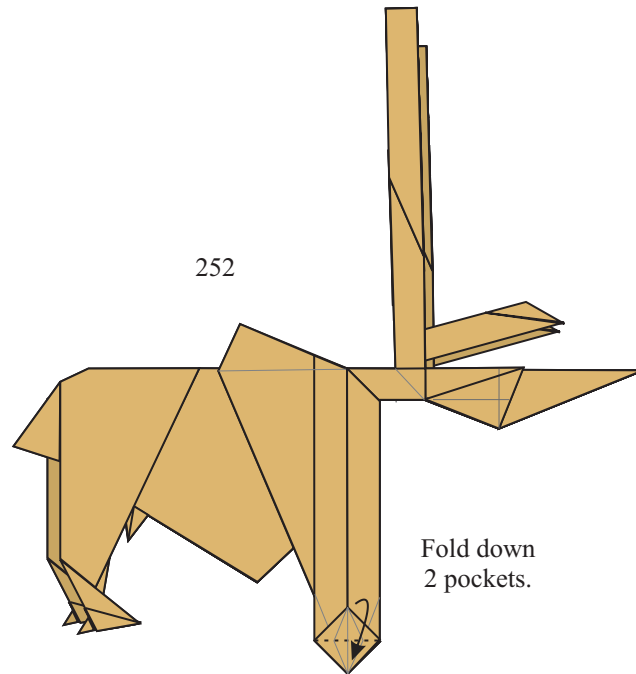
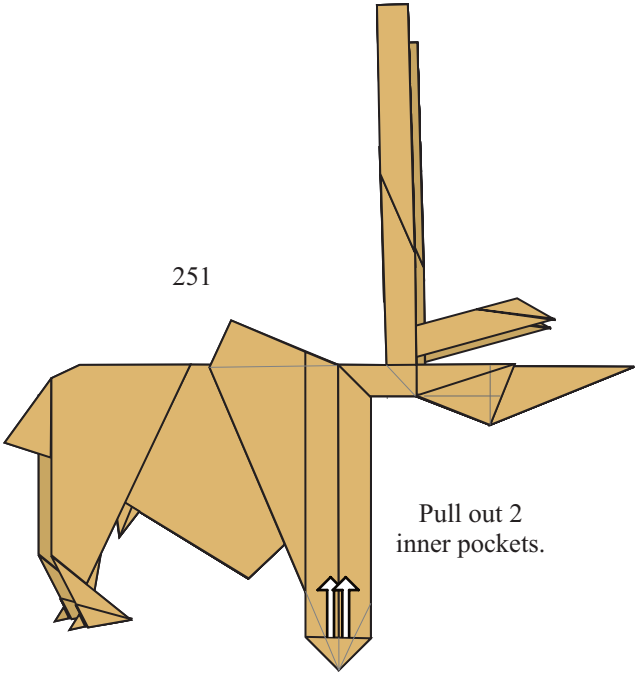
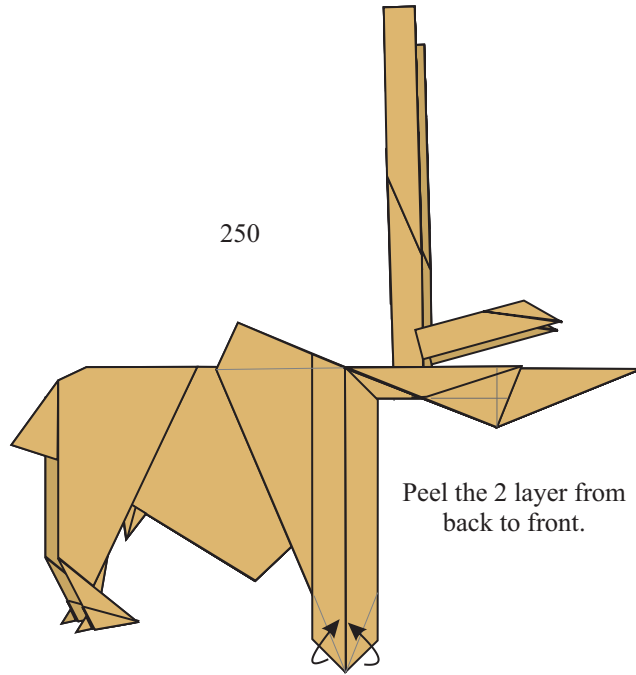
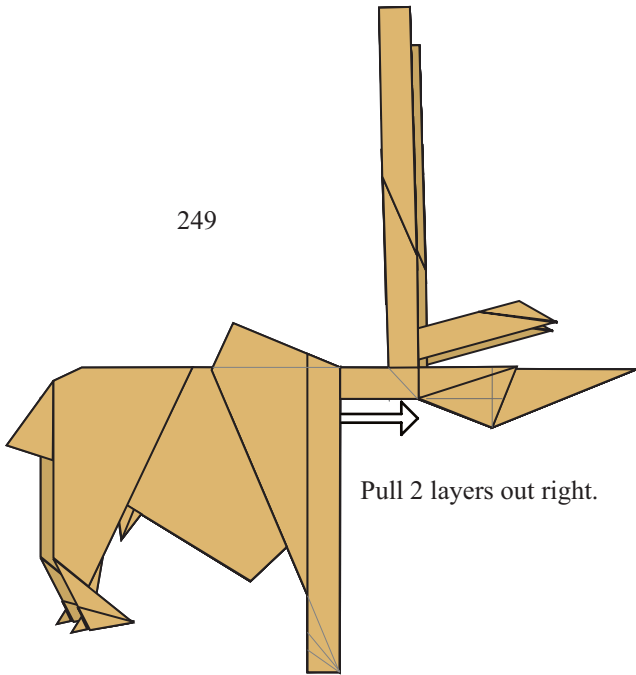

255

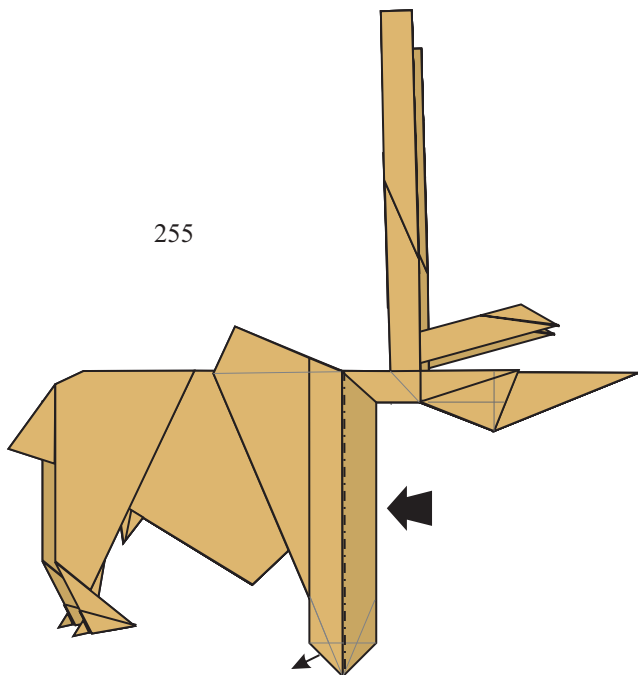

Push inside
to pull the under pocket out.

256

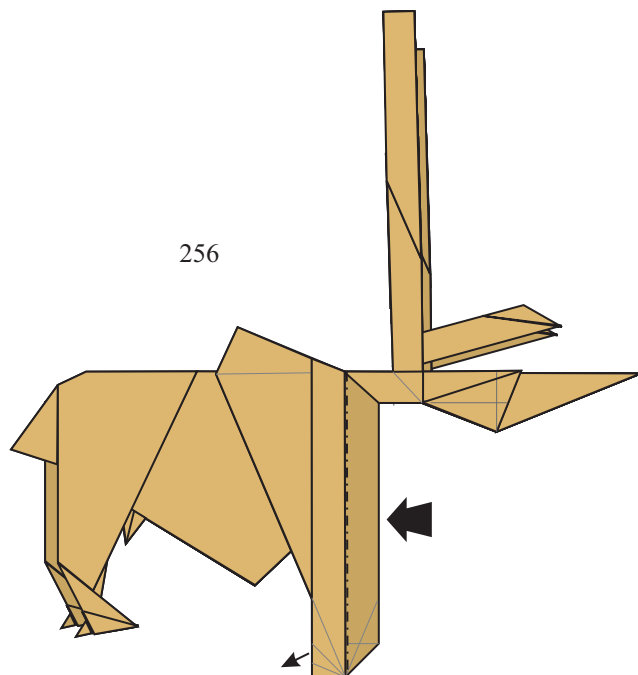

Repeat on the next pocket.

257

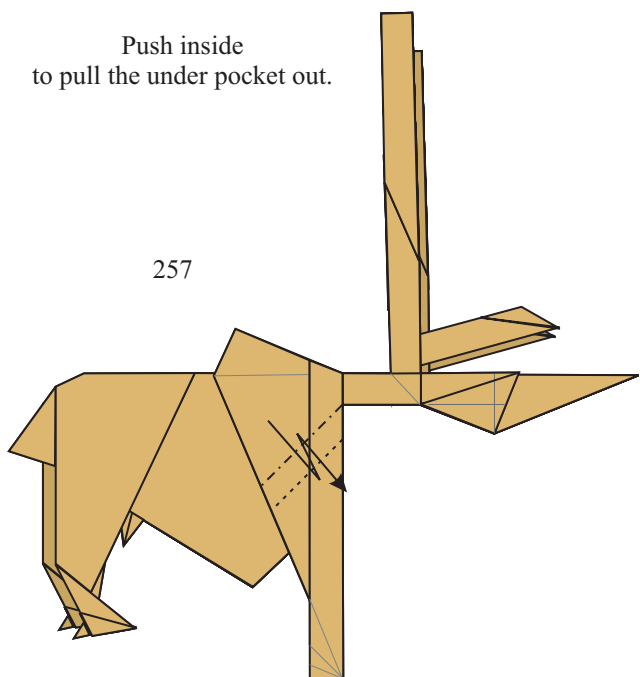

Pleat fold. Watch carefully.

258

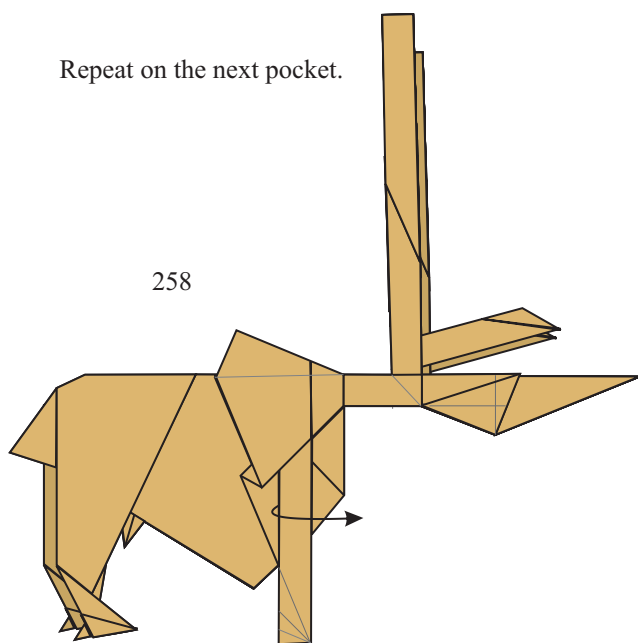

Open 2 layers to the right.

259

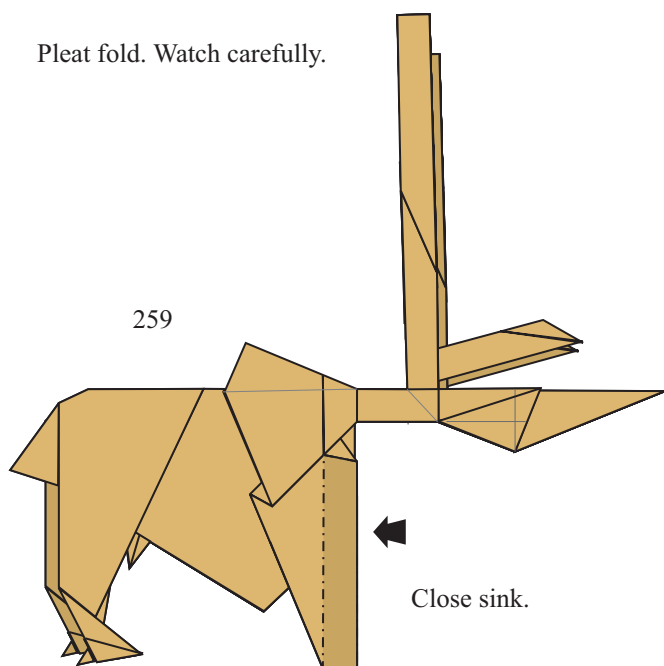

Close sink.

260

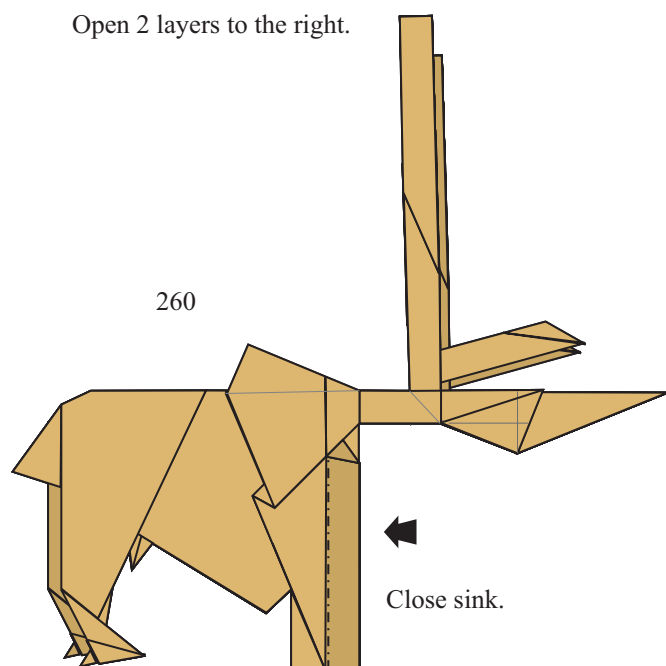

Close sink.

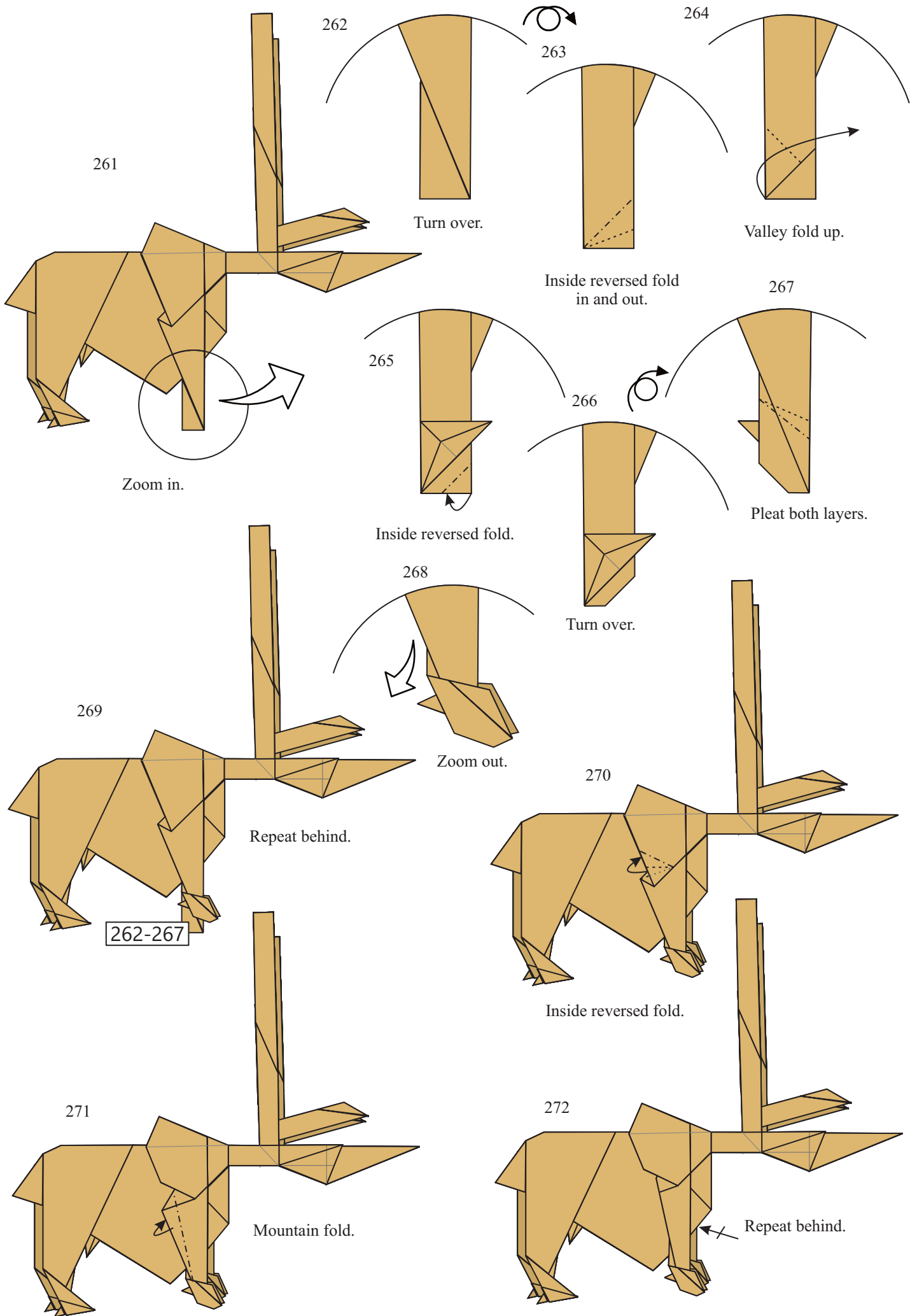

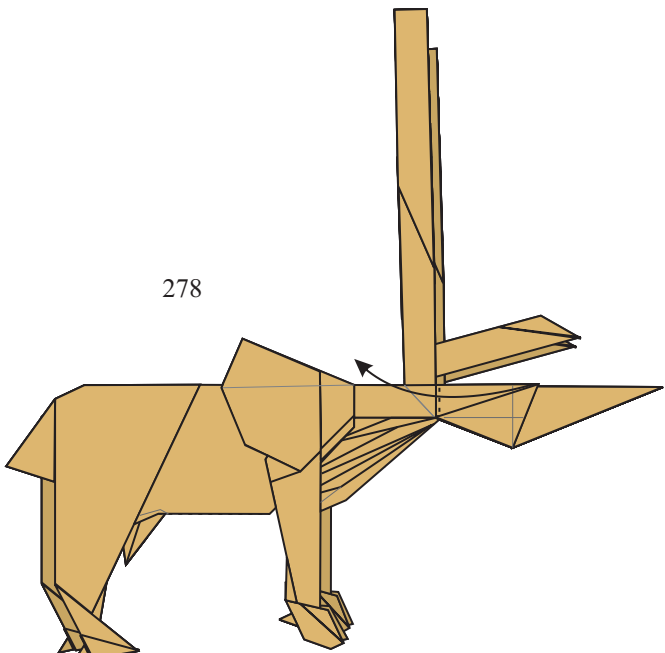
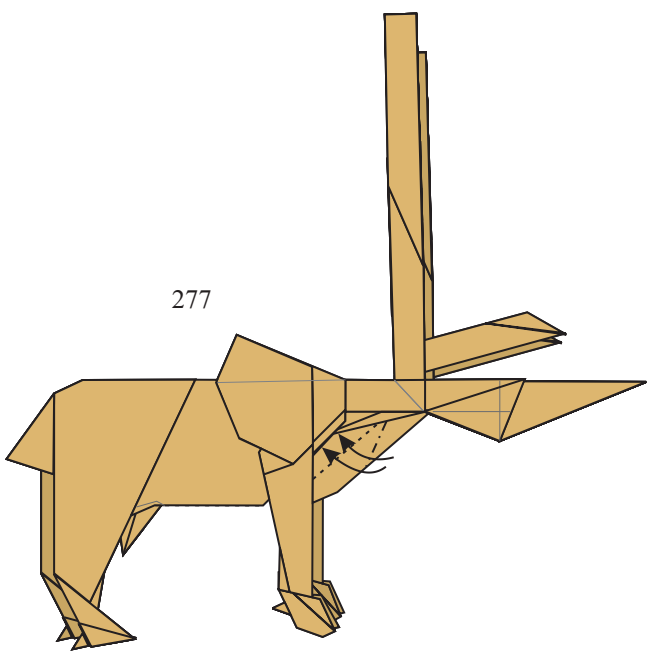
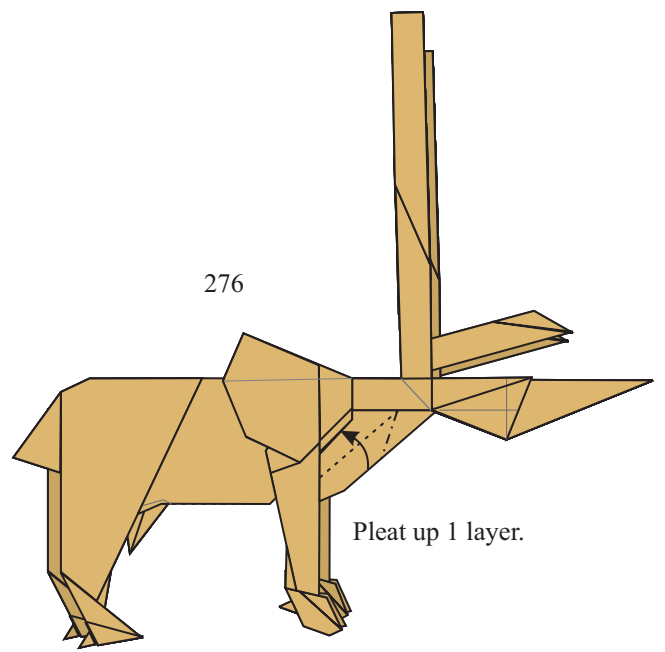
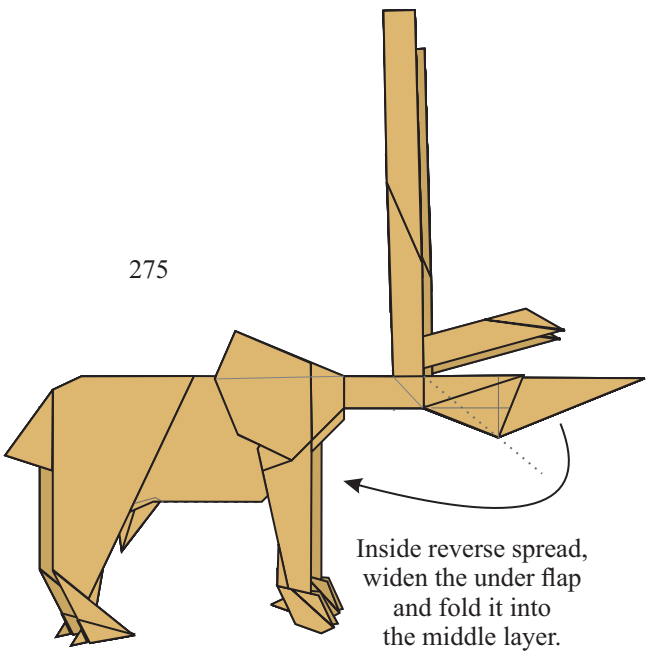
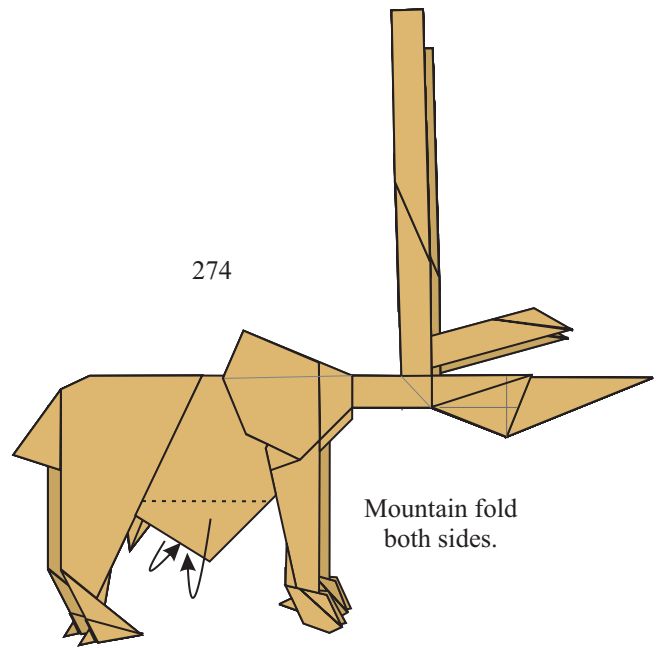
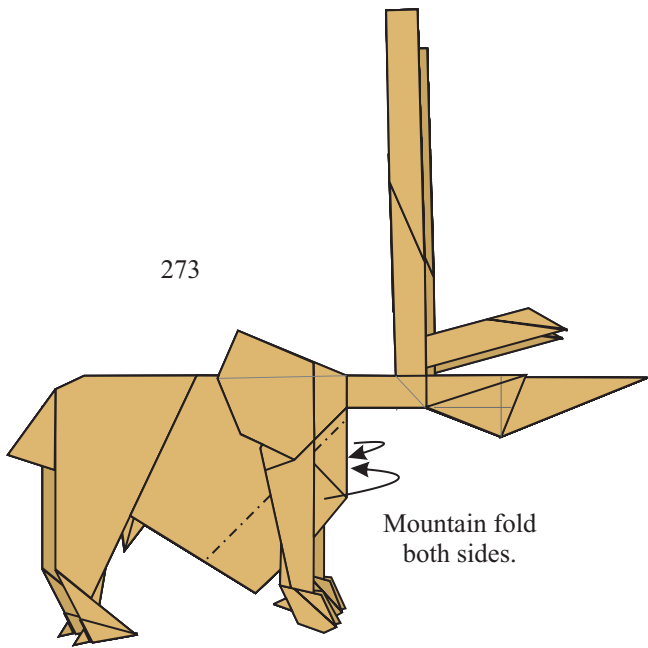

Pleat up the next 2 layers.

Fold the ear to the left.

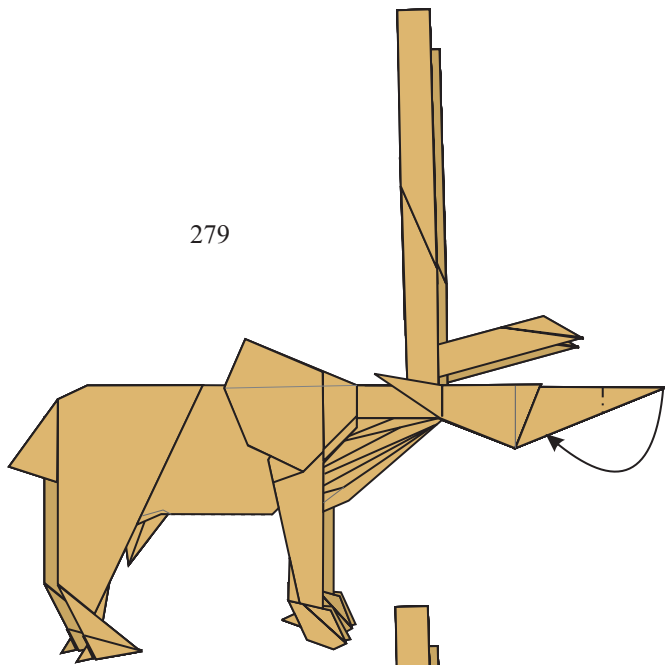

279

Inside reversed fold.

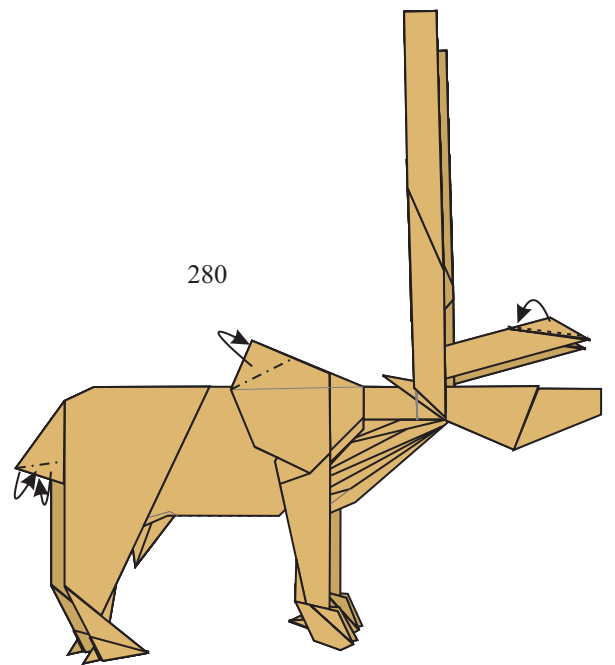

280

Mountain fold the tail, the shoulder and the horns.

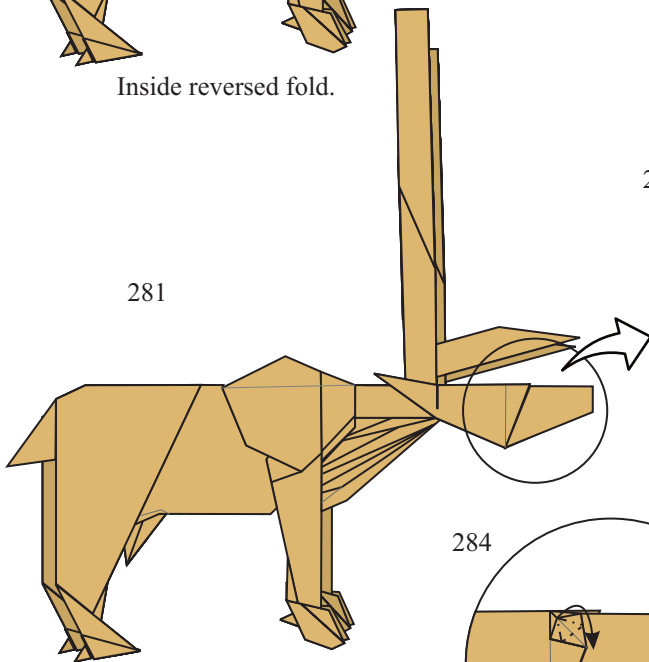

281

Zoom in.

282

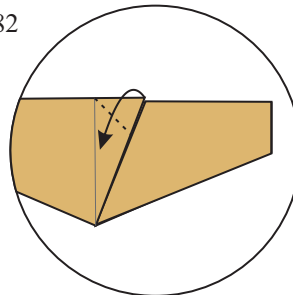

Valley fold.

283

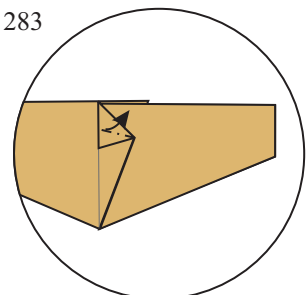

Small squash fold.

284

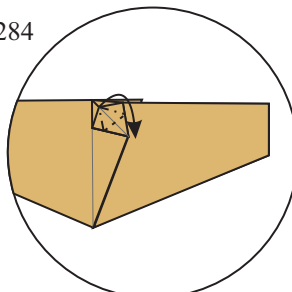

Petal fold.

285

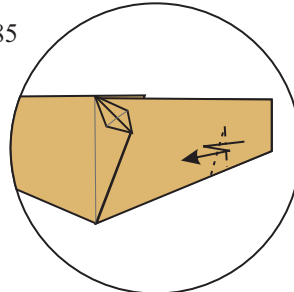

Pleat.

286

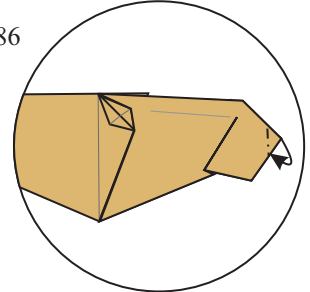

Small inside reversed fold.

287

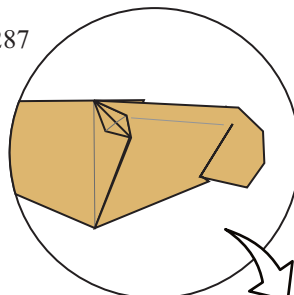

Zoom out

288

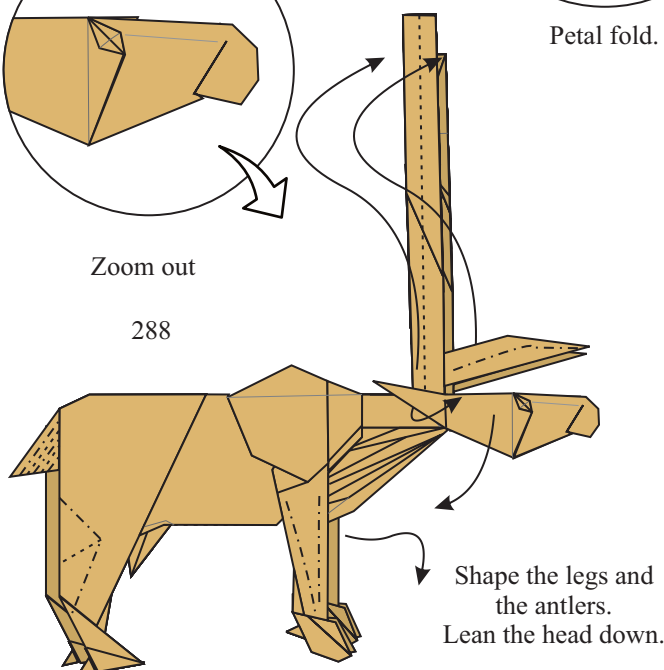

Shape the legs and the antlers.
Lean the head down.

289

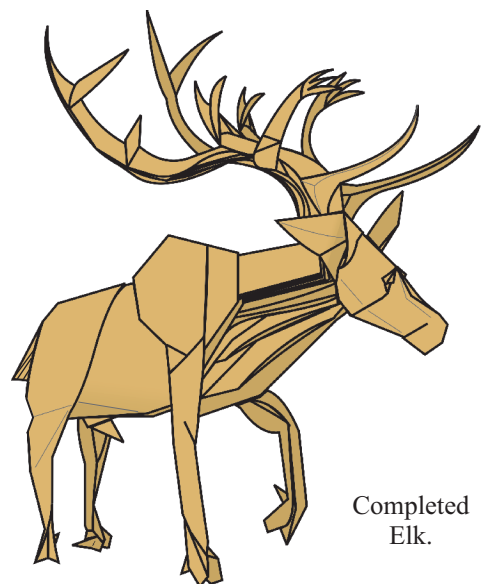

Completed Elk.

ELK 3.5

BY PHAM HOANG TUAN

Thank you for supporting me. Have a nice paper folding session and a peaceful day.

For any information, please contact via fanpage Hoang Tuan Origami. Or via gmail Origamer15@gmail.com.

This is confidential data, please do not share with anyone. That's how you can support and help me in particular, and help the origami art community in general. Because I have enough economic conditions, I have the motivation to create many beautiful works.



INSTRUCTION DIAGRAM