

OrigamiUSA

Origami Collection 2022

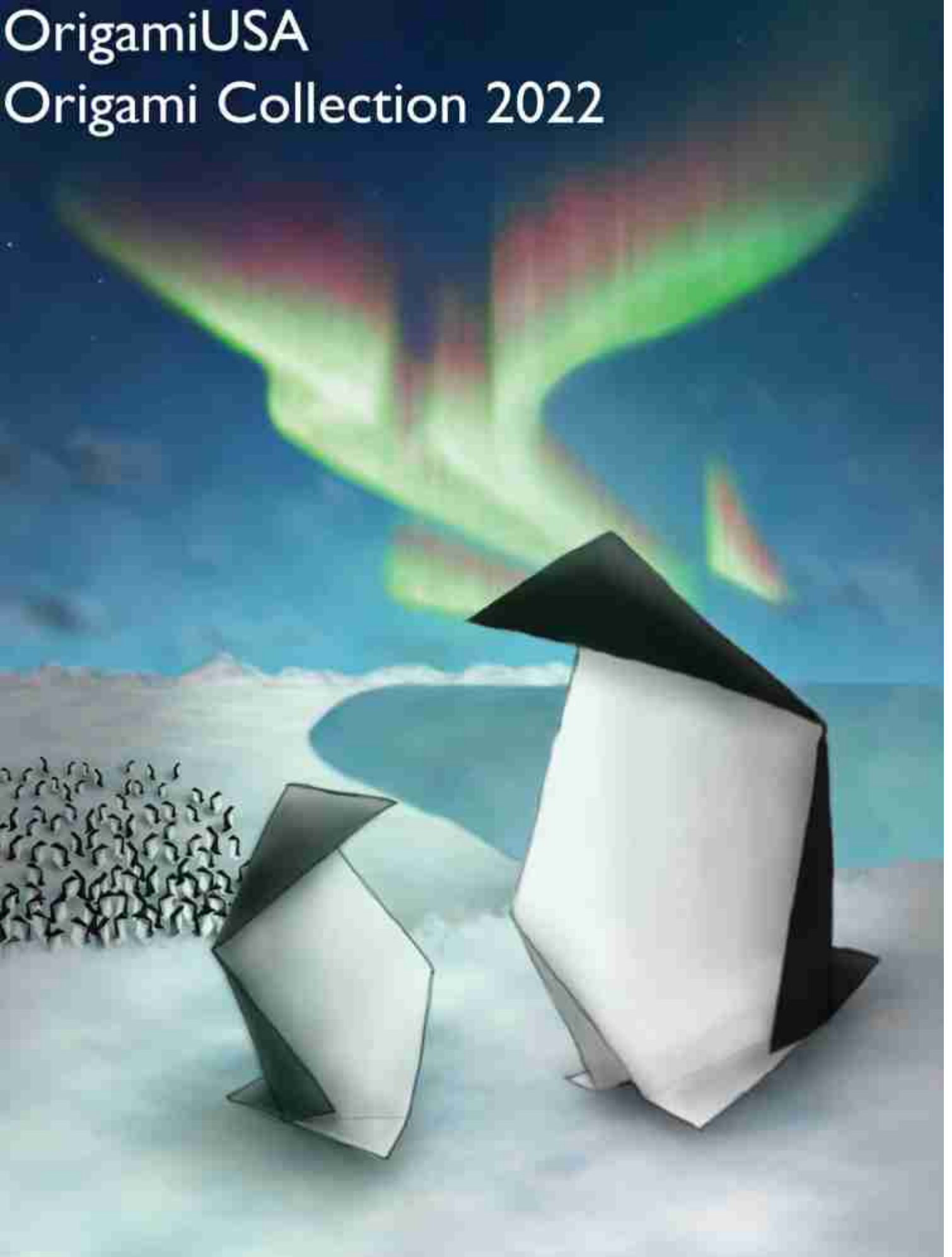

Origami Collection 2022

Copyright 2022 by OrigamiUSA, a volunteer-based, not-for-profit educational arts organization committed to the elucidation and dissemination of paperfolding as an art and a craft.

All rights reserved, including the right to reproduce this book or portions thereof in any form without prior written consent.

OrigamiUSA
15 West 77th Street
New York, NY 10024-5192
(212) 769-5635
origamiusa.org

Cover Illustration by Nathan Zeichner
Cover artwork based on *Penguin*, courtesy of Michael G. LaFosse

Origami Basics section by Marc Kirschenbaum

Publication Team	Managing Editors
Omer Shalev	Marc Kirschenbaum
Nathan Zeichner	JC Nolan
	Daniel Scher

Submissions to the Origami Collection and other OrigamiUSA publications can be sent to origami.usa.pub@gmail.com.

A submission form and copyright guidelines can be found at origamiusa.org/submissions.

Table of Contents

About the Collection	v
Picture Index	vi
The 2022 Origami Collection	1
Origami Basics	222

About the Origami Collection

The *Origami Collection* was born in 1980 from ideals fostered by the founding members of OrigamiUSA. Michael Shall (1949-1995) launched this yearly anthology to share origami models from around the world. His mentor, Lillian Oppenheimer (1898-1992), provided the springboard for this effort, as many of the models were drawn from her collection and connections she cultivated. Alice Gray (1914-1994) also provided inspiration by streamlining the communication of origami ideas. All of the novice-level works in this collection are dedicated to Alice and her love of simple, elegant pieces.

Throughout the years as our presentation has grown more polished, the goal of showcasing great origami has not diminished. The editors of the *Origami Collection* spend many hours curating, testing and editing origami designs to produce a book that will appeal to origami aficionados of all levels and interests. Variety is a key criterion; you will find works here by established origami artists as well as many hidden gems from up-and-coming stars. Most of the pieces are making their debut in these pages. We hope you are as excited about discovering these diagrams as we are in presenting them.

Picture Index



Alejo, Michel Condori
Cardinal
Page 1



Berty, Viviane
Bery of Bats
Page 21



Alexander, Richard L.
Three-Dollar Bird Base
Page 8



Bettens, Christiane
Tiny Pentagonal Tato Box
Page 33



Arroyo, Manuel
Dollar Bill Butterfly Bookmark
Page 10



Carminati, Alberto
Wren
Page 34



Arroyo, Manuel
Dollar Bill Rose
Page 12



Casey, Steven
Koala
Page 39

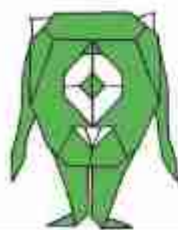

Artigas, Jesús
Baby Monster
Page 15



Chang, Michele
Dancing Penguin
Page 45



Chang, Michele
Qstgarðrian Hippocampus
Page 47



Ehara, Masayuki
Tiger
Page 59



Chapman-Bell, Philip
Falling Star Taro
Page 51



Ellison, Richard
Penguin and Chick
Page 64



Chen, Sy
Hopping Grasshopper
Page 53



Esteve, Oriol
Toy Unicorn
Page 70



Chen, Sy
Pureland Cicada
Page 54



Fialho de Menezes, Ary
Dragon
Page 74



Chen, Sy
Tetramino Snake
Page 55



Frasco, Paul
Triceratops Plane
Page 77



Harrington, Kyle
Kyle Ren
Page 82

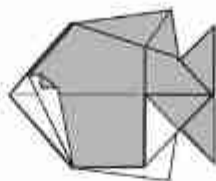

LaFosse, Michael G.
Angel Fish
Page 102



Hossien Khani, Mahyar
Shining Octagon
Page 85

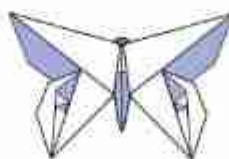

LaFosse, Michael G.
A Butterfly for Rana Benjamin
Page 105



Kirschenbaum, Marc
Hippo
Page 88



LaFosse, Michael G.
Ginkgo Leaf
Page 107

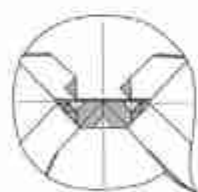

Kobayashi, Hiroaki
Ghost
Page 94



LaFosse, Michael G.
Penguin
Page 108



LaBoone, Matt
Hummingbird
Page 98



LaFosse, Michael G.
Samurai Helmet
Page 109



Li, Qingquan
Cat
Page 112

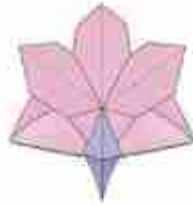

Marlina, Linda
Beautiful Orchid
Page 130



Li, Qingquan
Sparrow
Page 117



Mortazavi, Nina
Freedom Tower
Page 133



Louis, Gareth
Pureland Guitarist
Page 123



Nir, Yossi
Flawless Ball
Page 136



Louis, Gareth
Pureland Sailboat
Page 125



Ortiz, Maximiliano
Josefa Star
Page 140



Louis, Gareth
Toucan
Page 127

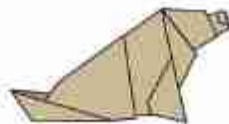

Patki, Shriram
Sitting Dog
Page 142



Peled, Yehuda
Rabbit
Page 144



Samboga, Rafa Mulen
Crown Star
Page 151



Robinson, Nick
Flexi Fish Form
Page 147



Sánchez-Biezma, Fernando
Goat
Page 153



Robinson, Nick
Hermit Crab
Page 148



Sánchez-Biezma, Fernando
Helix
Page 167

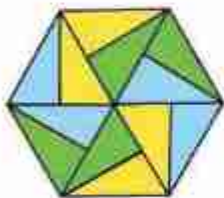

Robinson, Nick
Hexagonal Coaster
Page 149



Sánchez, Daniel Bermejo
Dragon
Page 161



Robinson, Nick
Leftover Flower
Page 150



Sarvi, Reza
Damayand Volcano
Page 165



Sarvi, Reza
Zombie Hand
Page 168



Soepono, Herdy
Sailboat
Page 187



Seif, Izzy
Super Hero
Page 171



Szinger, John
California Sea Lion
Page 188

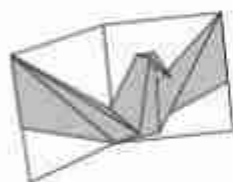

Shafer, Jeremy
Brd of Peace Pop-up Card
Page 179

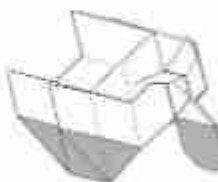

Tahir, Hadi
Keitenkraft rad
Page 193



Shafer, Jeremy
Heart Hand Crane
Page 181



Tahir, Hadi
Two Hearts
Page 220



Shafer, Jeremy
Worm in an Apple
Page 184



Terry, Nicolas
Rooster
Page 198



Trollip, Quentin
Turtle Love
Page 206



Yao, Xiao
Christmas Knot
Page 212



Zicker, William
Envelope
Page 218



Zodl, Evan
Two-Tone Star
Page 219

OrigamiUSA Origami Collection 2022

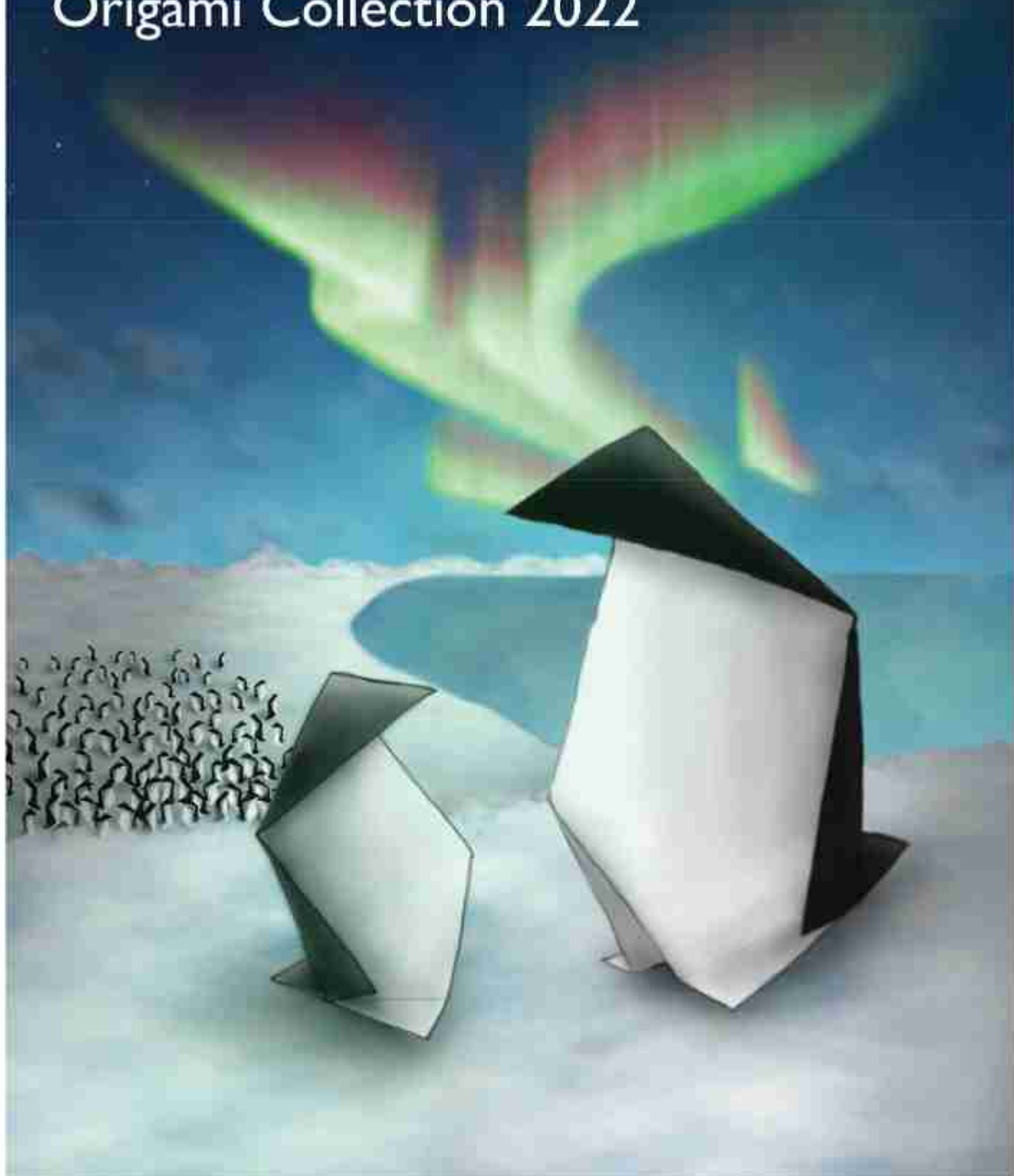

Cardinal

Complex

Michel Condori Alejo

©2021 - Bolivia

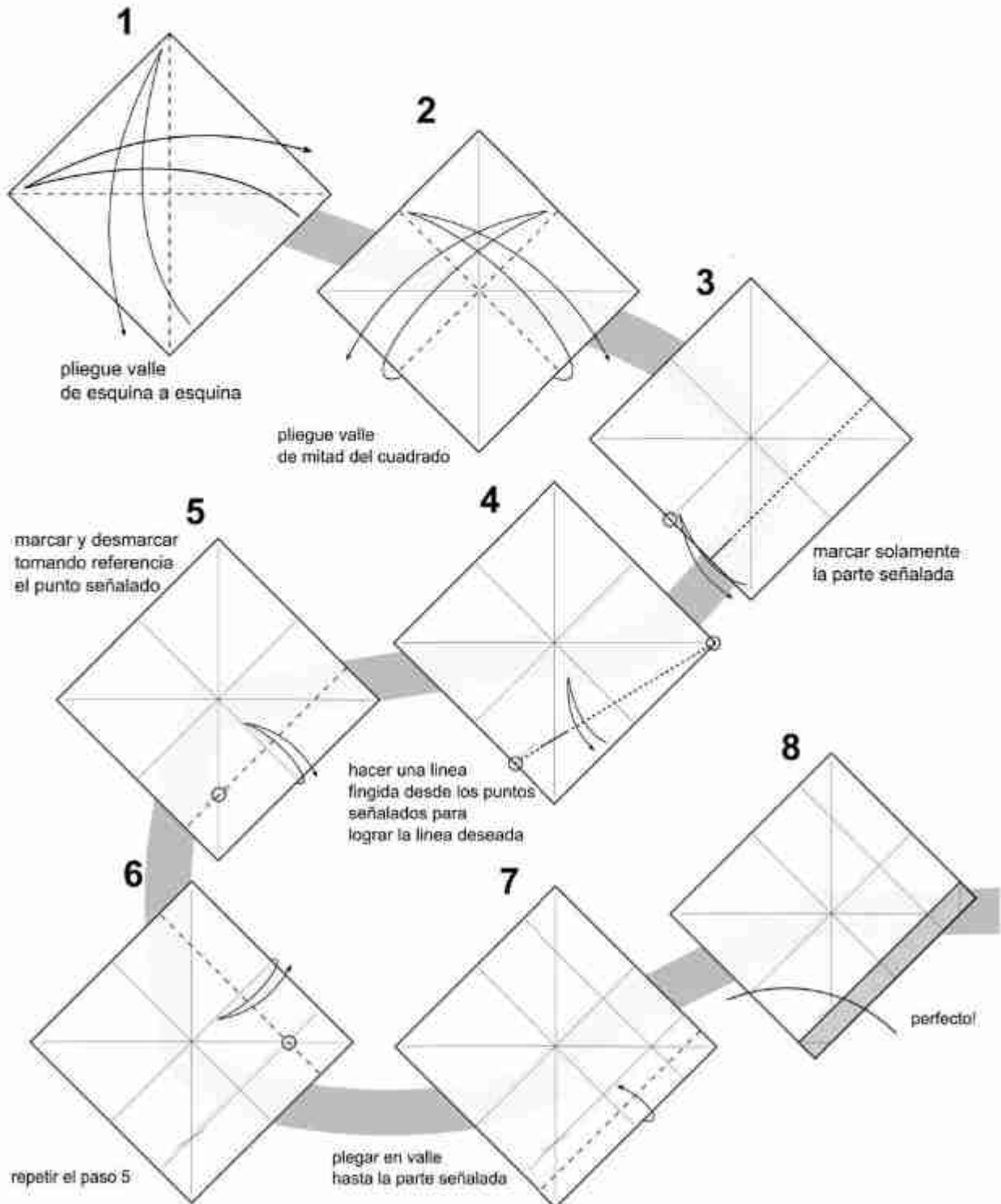

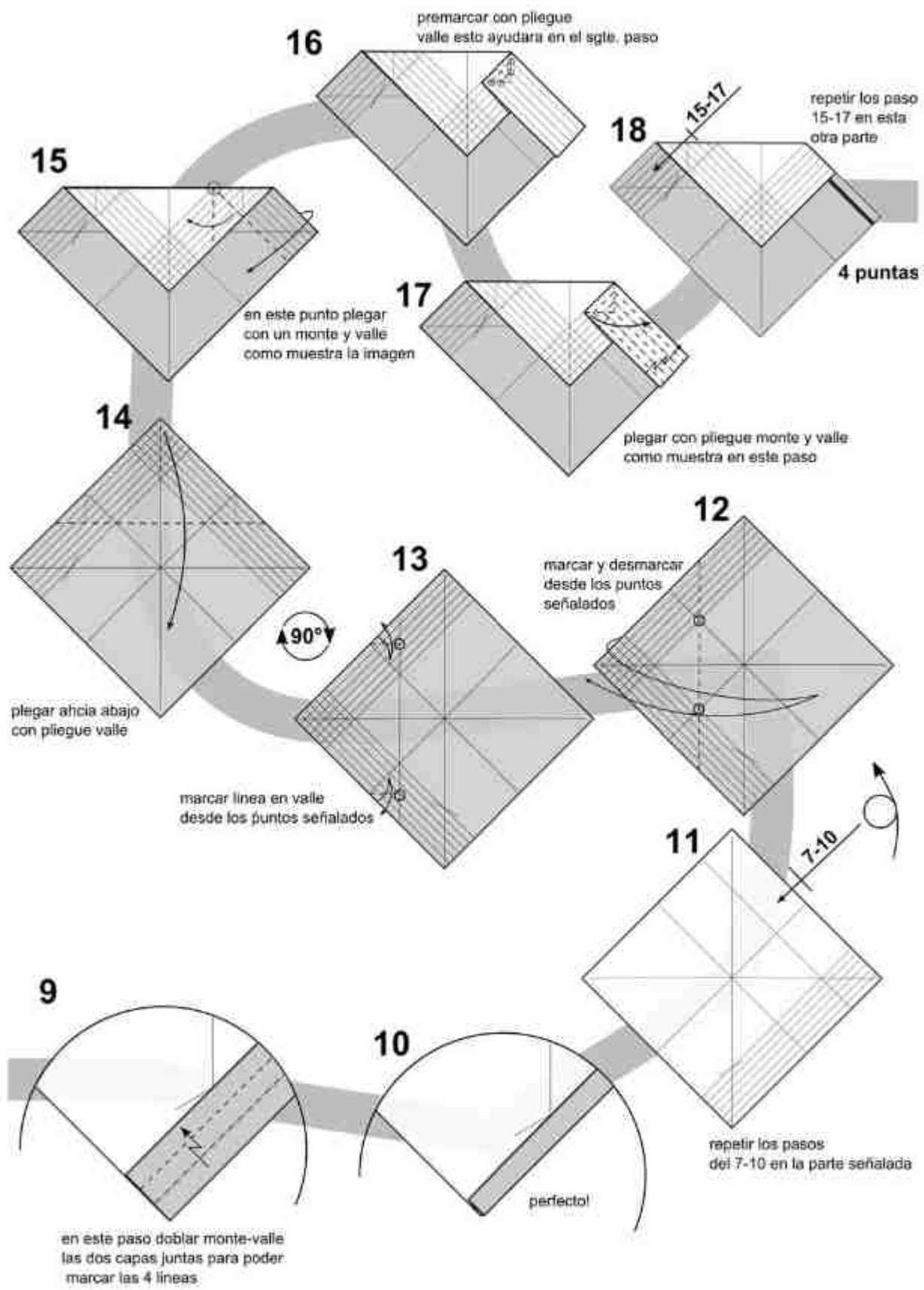

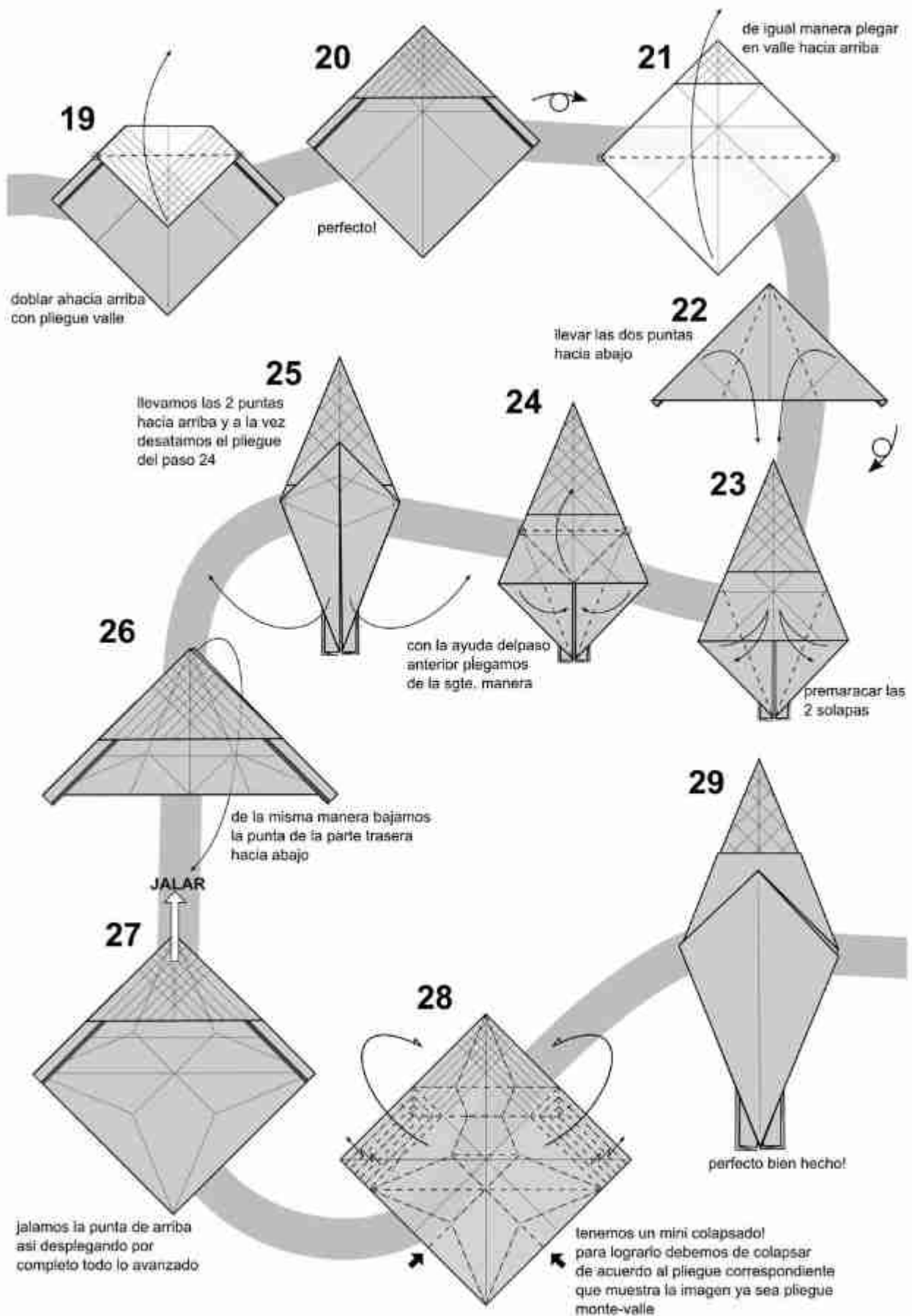

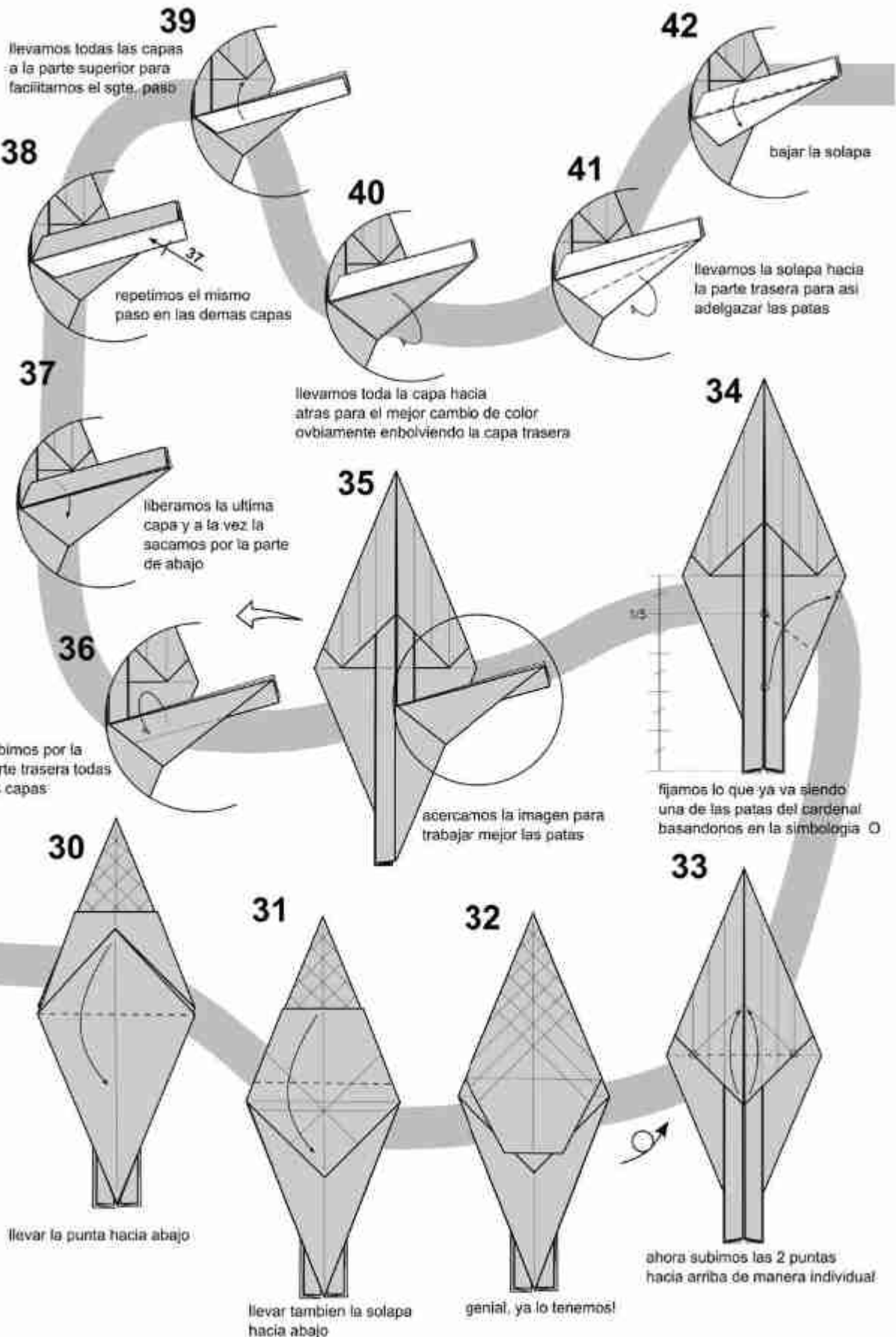

43

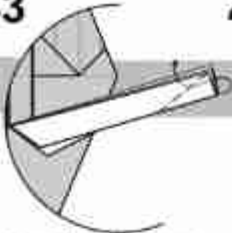

hacemos un pliegue interno

44



ahora hacemos lo mismo para hacer una punta

45

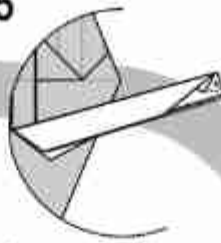

y hacemos el ultimo, genial!

46

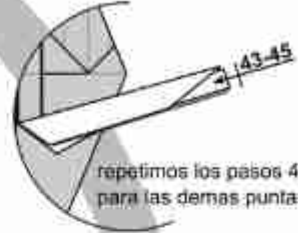

repetimos los pasos 43-45 para las demas puntas

49

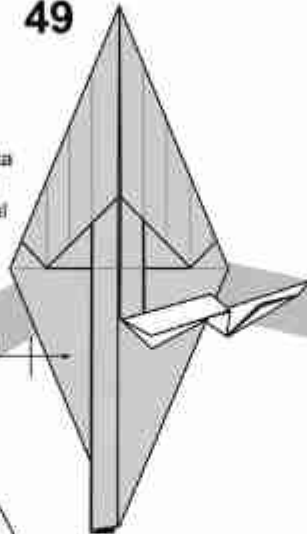

repetimos los pasos 34-48 en esta otra pata, y así ya terminaríamos con las patas de nuestro cardinal

34-48

47

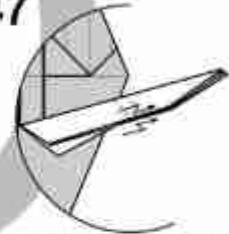

ahora hacemos un pliegue monta-vañe para darle forma a la pata del cardinal

48

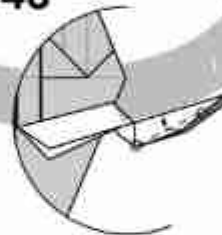

llevamos las capas hacia arriba

50

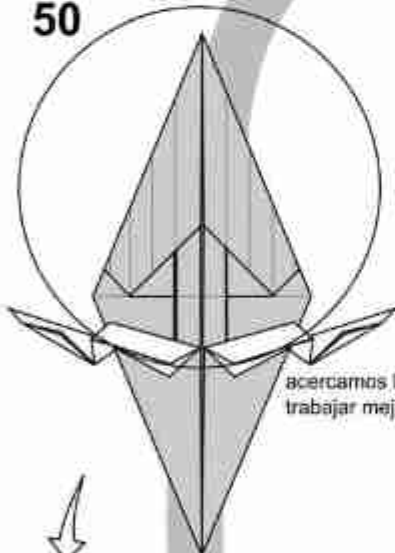

acercamos la imagen para trabajar mejor la cabeza

54

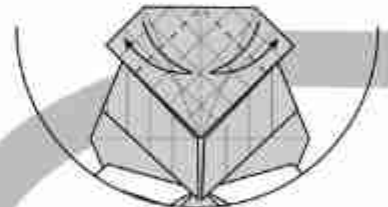

premarcamos las 2 solapas

53

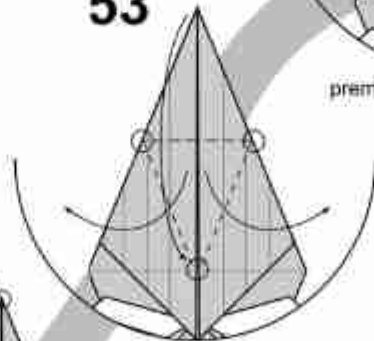

abrimos las 2 solapas y bajamos la punta central hasta el dicho punto O

51

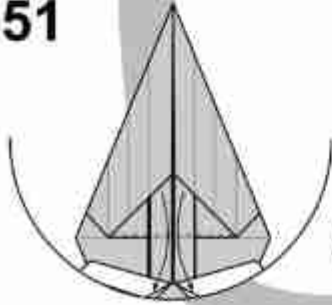

llevamos las 2 puntas hacia abajo, para realizar el sgte. paso

52

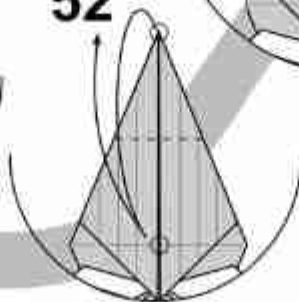

premarcamos dicha linea

63

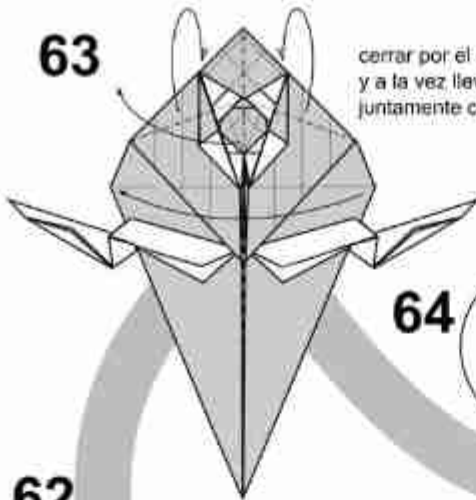

cerrar por el centro con pliegue valle y a la vez llevar hacia arriba la punta juntamente con el pico

65

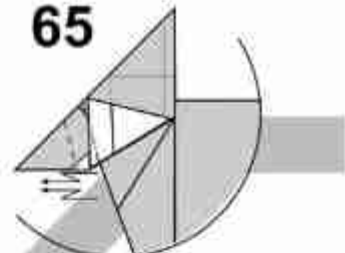

realizamos los pliegues monte-valle para definir el pico

64

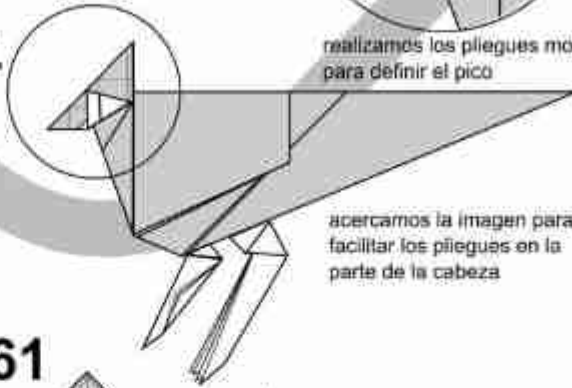

acercamos la imagen para facilitar los pliegues en la parte de la cabeza

62



llevar hacia adentro las 2 solapas

61



realizar un pliegue monte para delimitar el cambio de color de los ojos

55

undir la parte sombreada

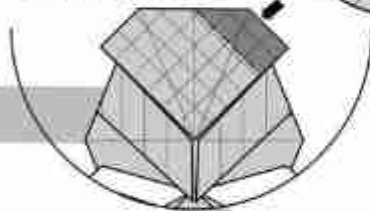
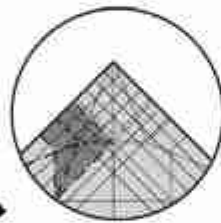

60



llevar las 2 solapas hacia el centro así realizando el cambio de color

56

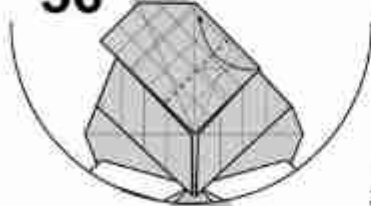

llevar la solapa para arriba y a la vez liberar la solapa interna

59



hacemos un pliegue monte-valle para formar el pico

57

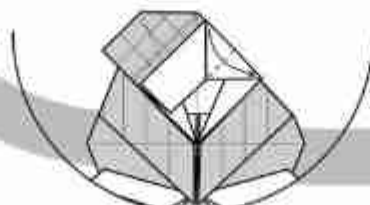

ya liberada y aplastada la solapa interna, bajamos otra vez la solapa

58



repetir los pasos 55-57 en la otra solapa

66

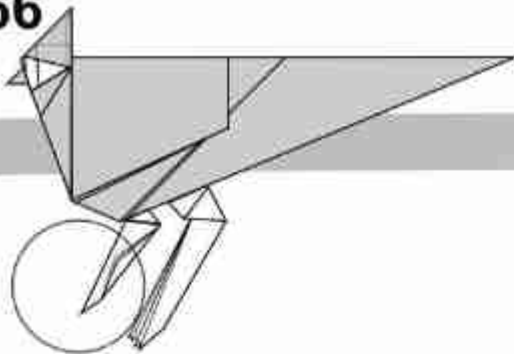

acercamos la vision para detallar las patas del cardenal

67



llevamos la punta hacia atras ya que es el dedo unico de atras

68



adelgazamos los 4 dedos con pliegue valle

69



realizamos pliegues valle-monte para elevar los 3 dedos restantes

70



perfecto!

71

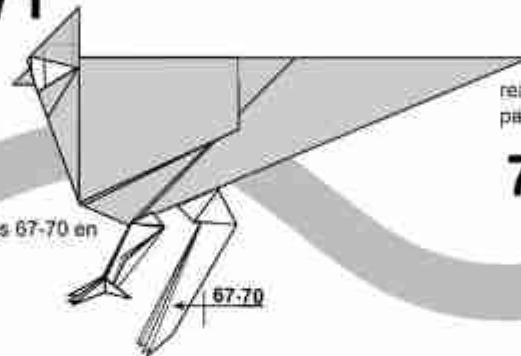

realizar los pasos 67-70 en la otra pata

72

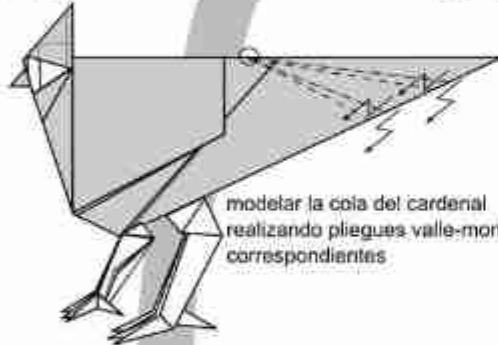

modelar la coia del cardenal realizando pliegues valle-monte correspondientes

73

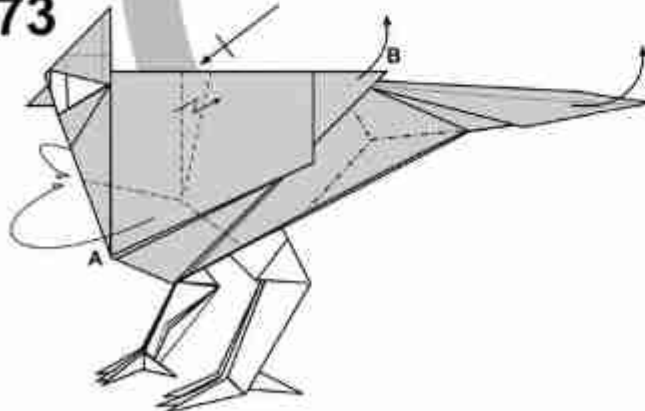

para finalizar con el modelo realizamos los sgtes. pasos pliegues valle-monte, y a la vez llevar hacia abajo las solapas del punto A, modelar coia llevandola hacia arriba como tambien la del punto B.

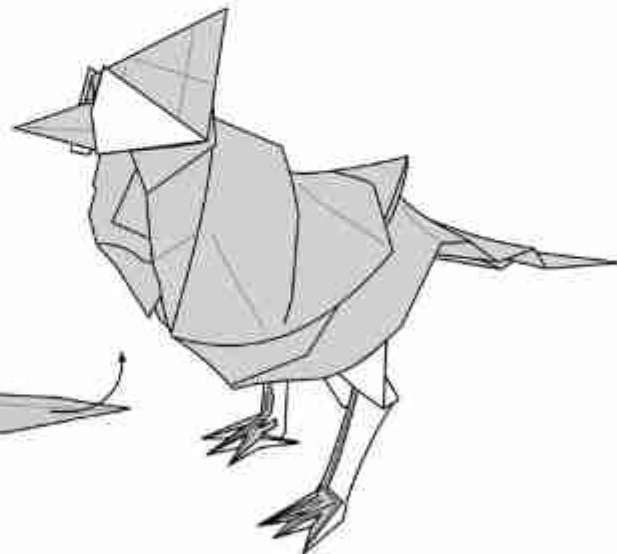

{genial, modelo terminado!}

Three-Dollar Bird Base

Richard L. Alexander
Michael LaFosse (dgrms.)
©2010 - USA

Intermediate

Requires three US Dollar bills.
the completed Bird Base will be the same size as one
folded from a standard 15 cm square of origami paper!

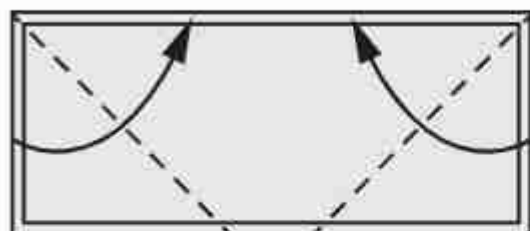

1

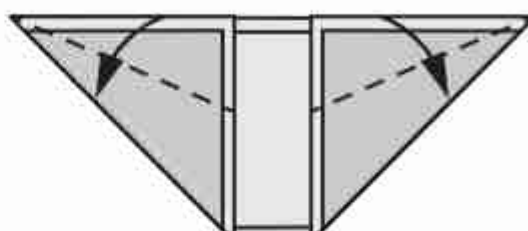

2

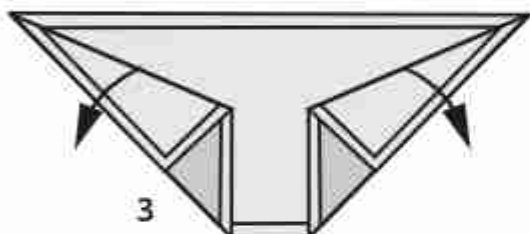

3

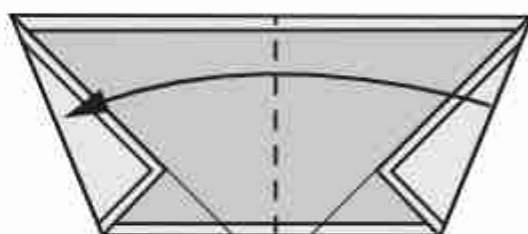

4

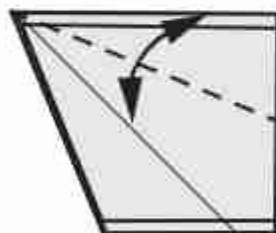

5

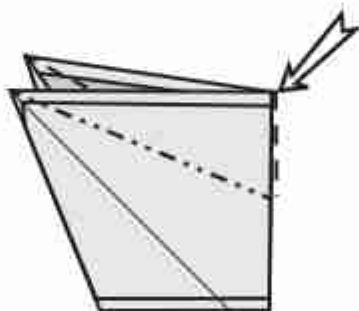

6

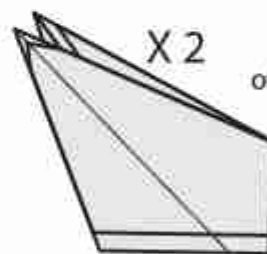

7

X2 Fold two of these units

Now fold one of these:

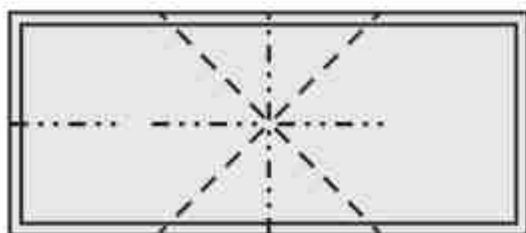

1

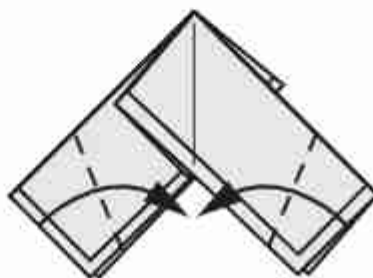

2

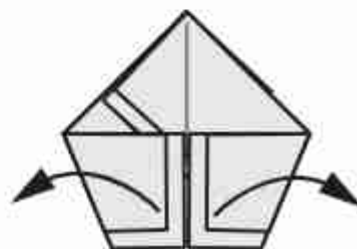

3

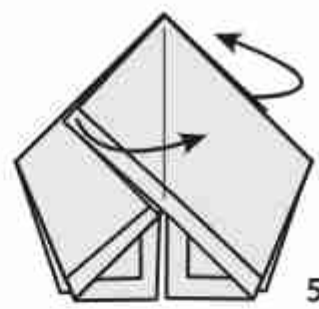
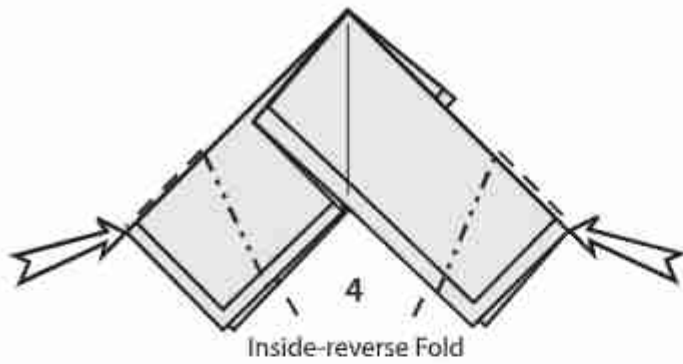

Swing the four
flaps to be
perpendicular
to each other



Assemble the three units to complete the Bird Base:

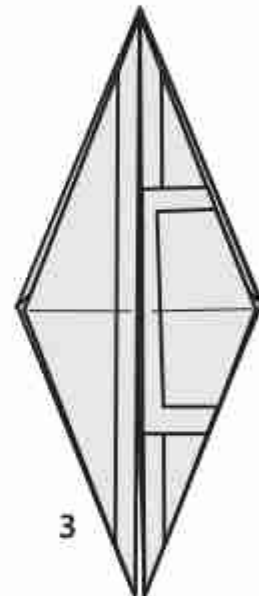
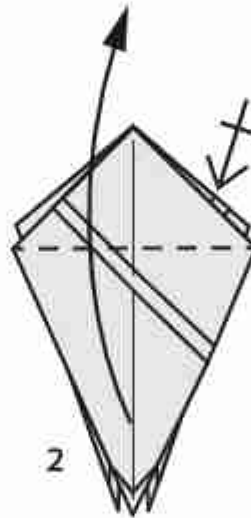
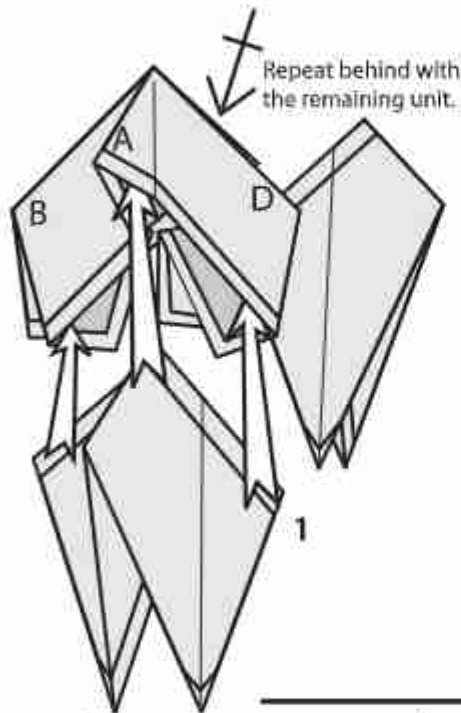

Now fold a Crane or any other Bird Base origami model!

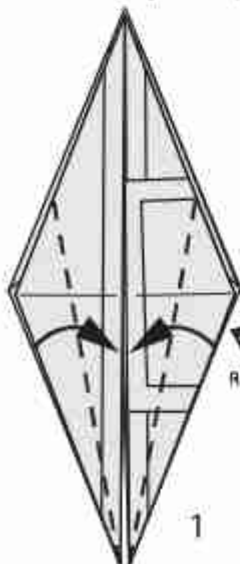

Repeat behind

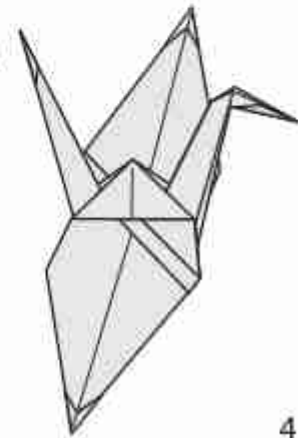
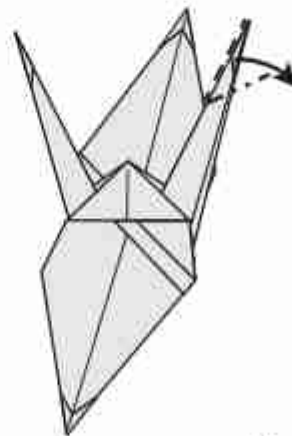

Dollar Bill Butterfly Bookmark

Manuel Arroyo
©2021 - Spain

Intermediate

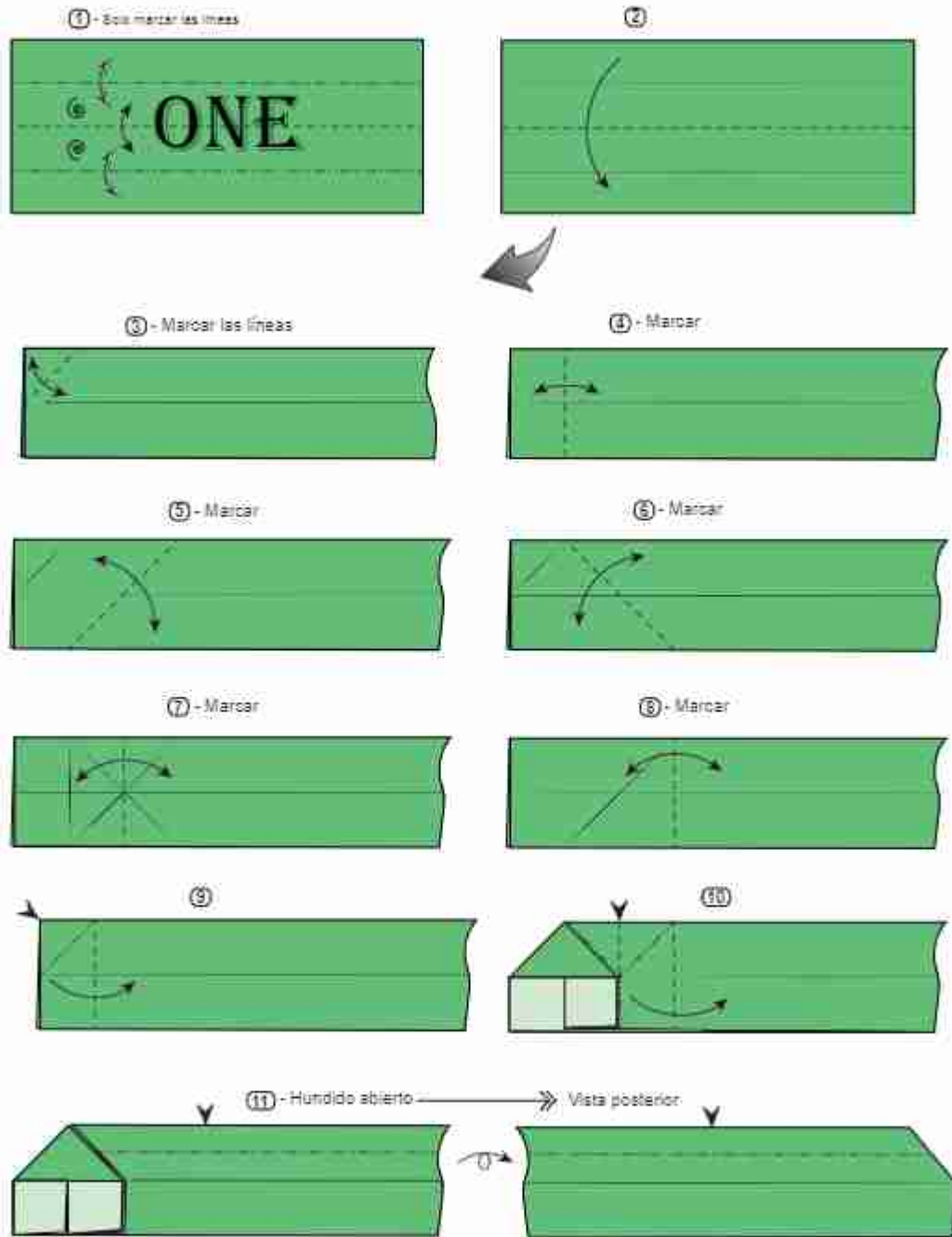

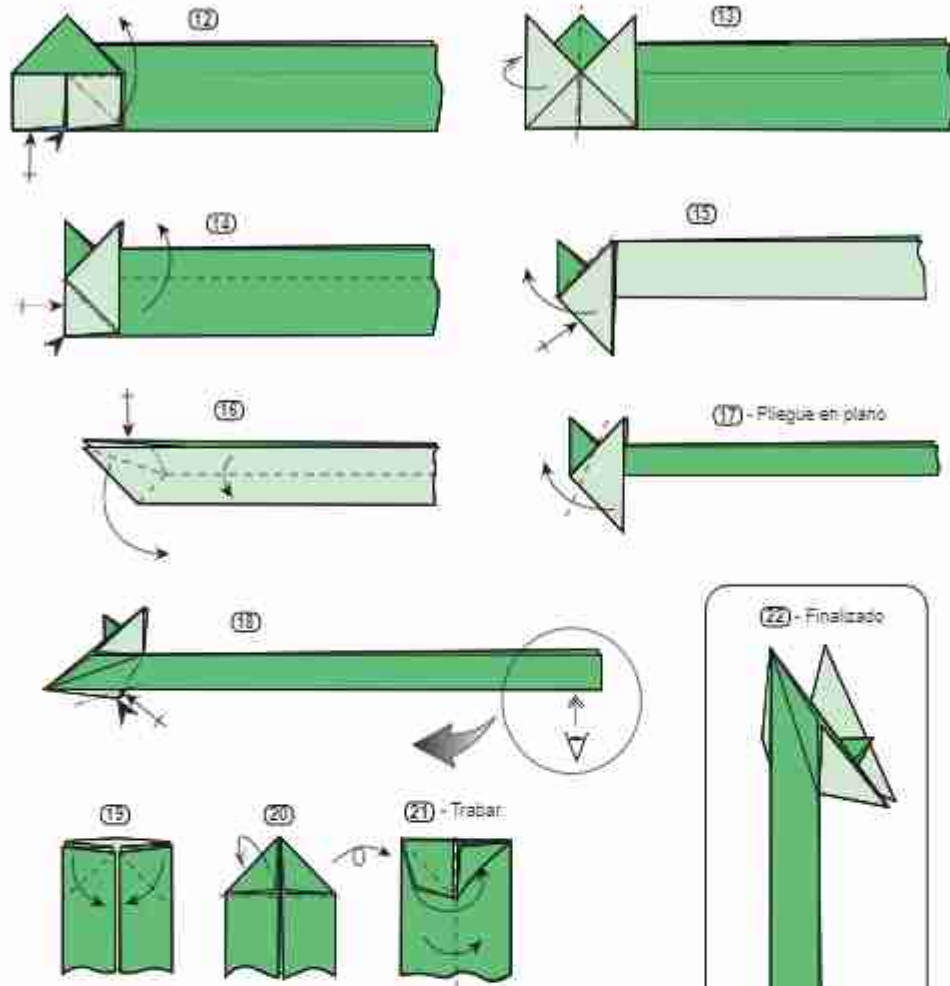

Dollar Bill Rose

Manuel Arroyo

©2021 - Spain

High Intermediate

① - Marcar



② - Doblar sin marcar
(solo para tomar referencia)

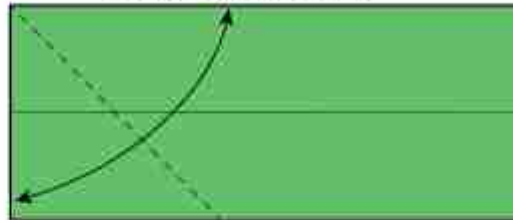

③ - Marcar y desdoblar

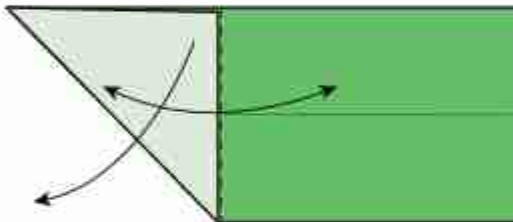

④

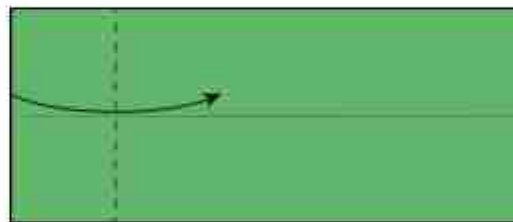

⑤ - Marcar todas las capas

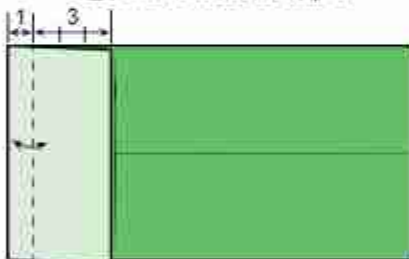

⑥

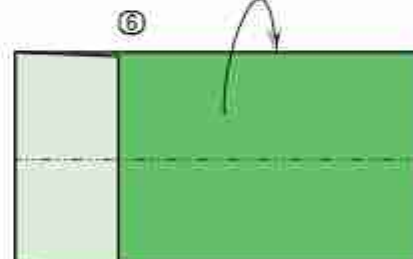

⑦ - Marcar en ambos sentidos.



⑧ - Marcar y desdoblar



⑨

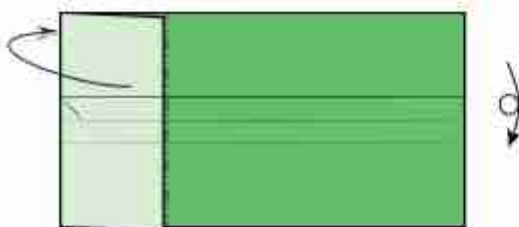

⑩ - Marcar

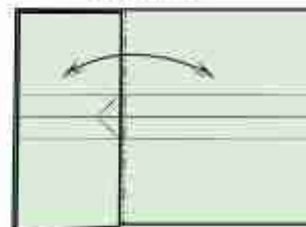

(11) - Realizar el hundido primero

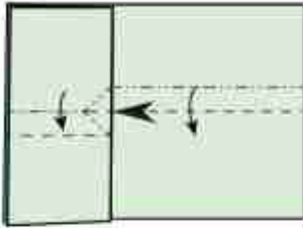

(12) - Doblar la capa superior

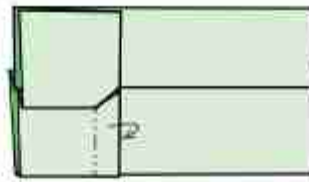

(13)

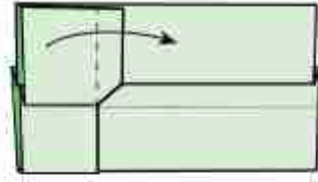

(14)

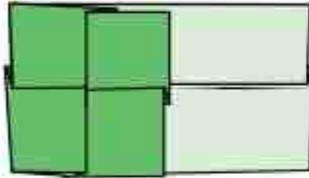

(15) - Debe quedar en 3D

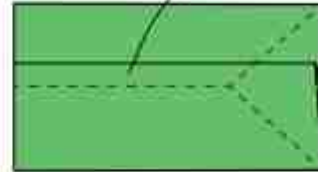

(16) - 3D

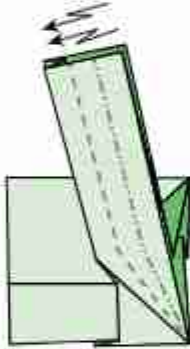

(17) - Girar el modelo

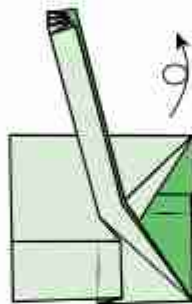

(18) - Ajustar los pliegues inferiores del tallo

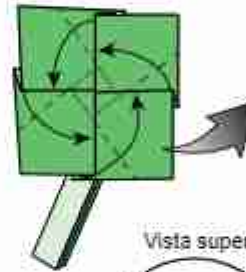

Paso intermedio

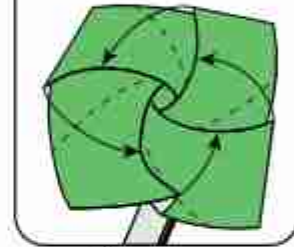

Vista superior



(19) - Cada pliegue, traba el anterior

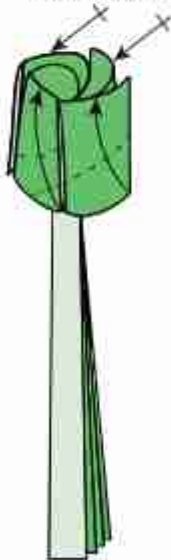

(20) - Trabaja hacia el interior

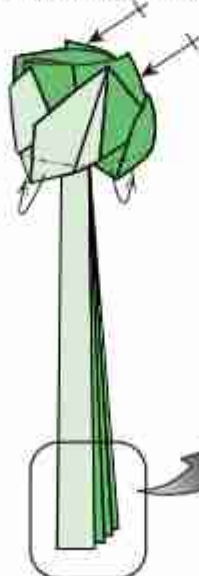

(21) - Solo marcar

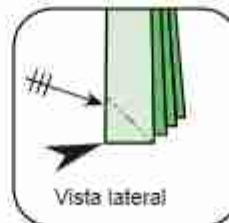

Vista lateral

(22) - Abrir el tallo

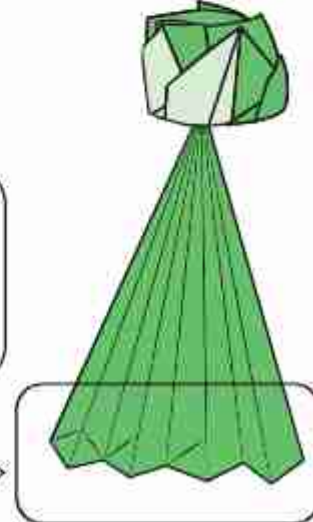

23 - Líneas en zig-zag.
Ver siguiente figura

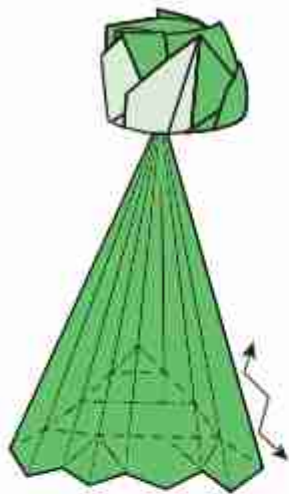

24

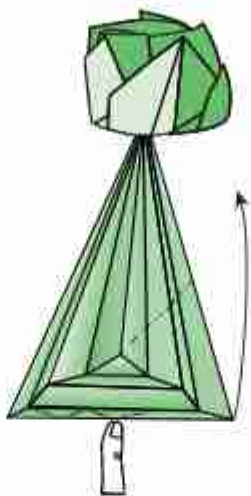

25

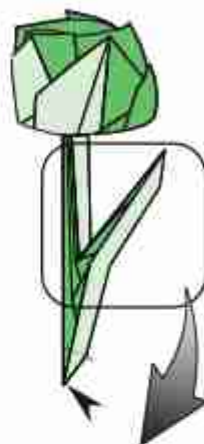

26

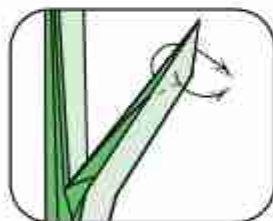

27 - Esconder la punta

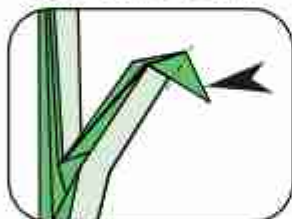

28 - Abrir la hoja



29 - Redondear

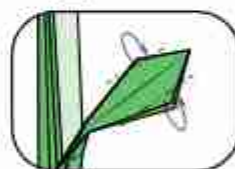

30 - Doblar todas las
capas y ajustar la hoja

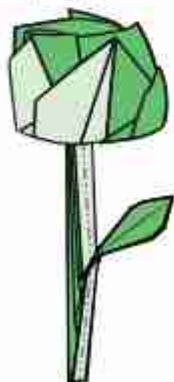

31 - Abrir los pétalos



32 - Modelo finalizado

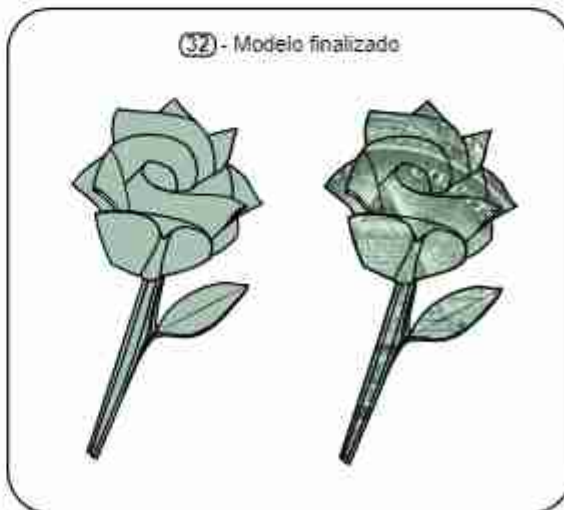

Baby Monster

Intermediate

Jesús Artigas

©2017 - Spain

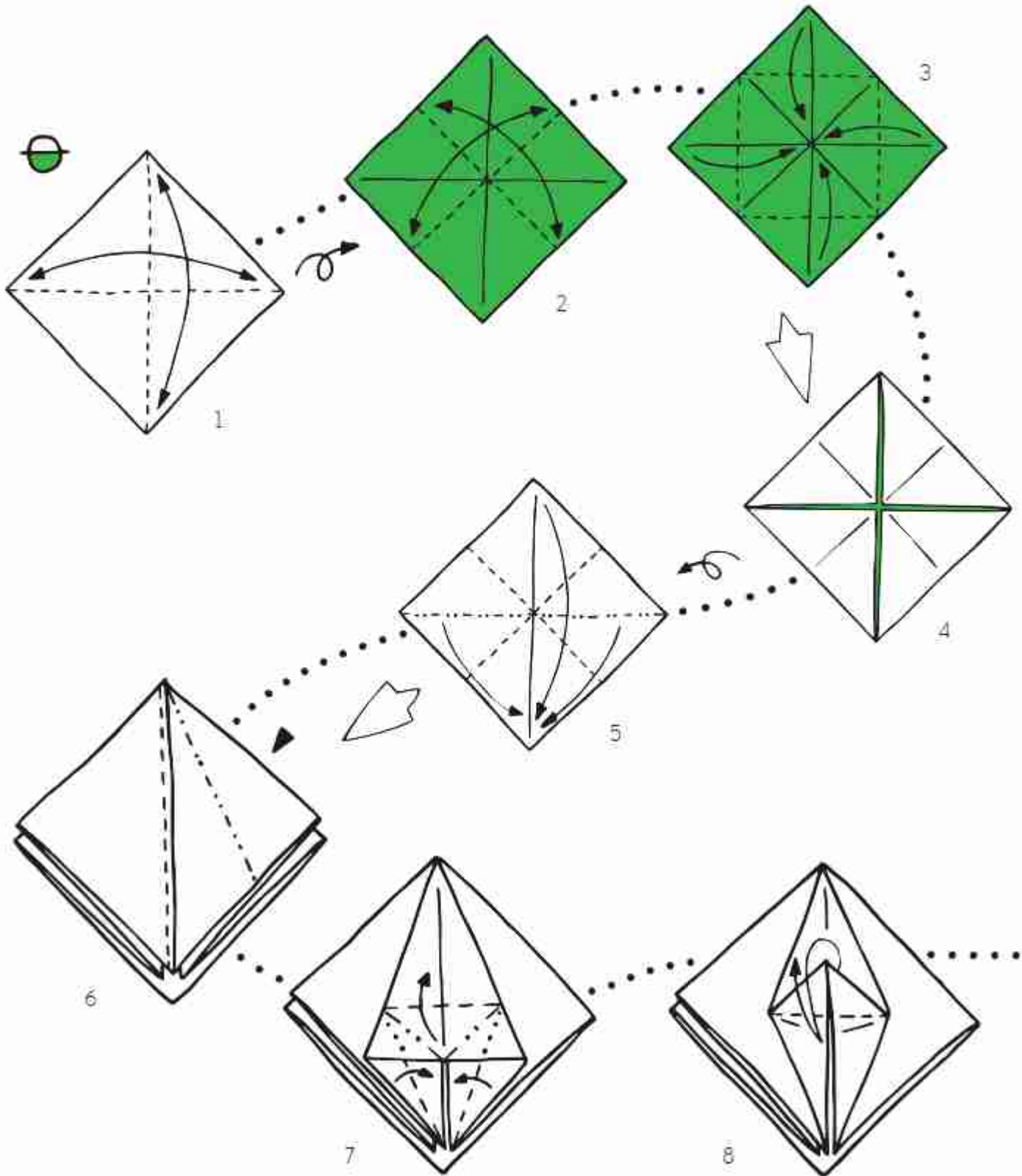

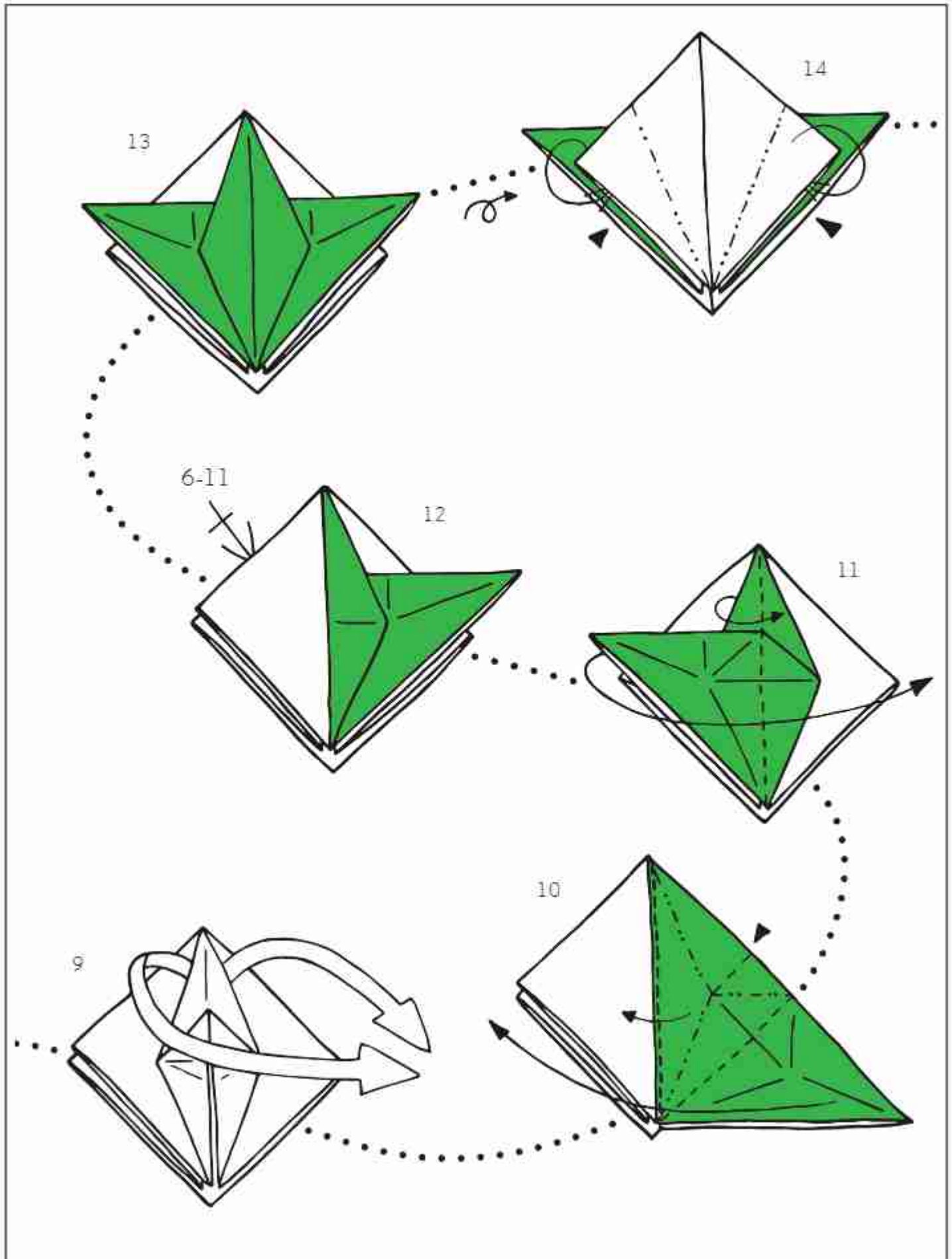

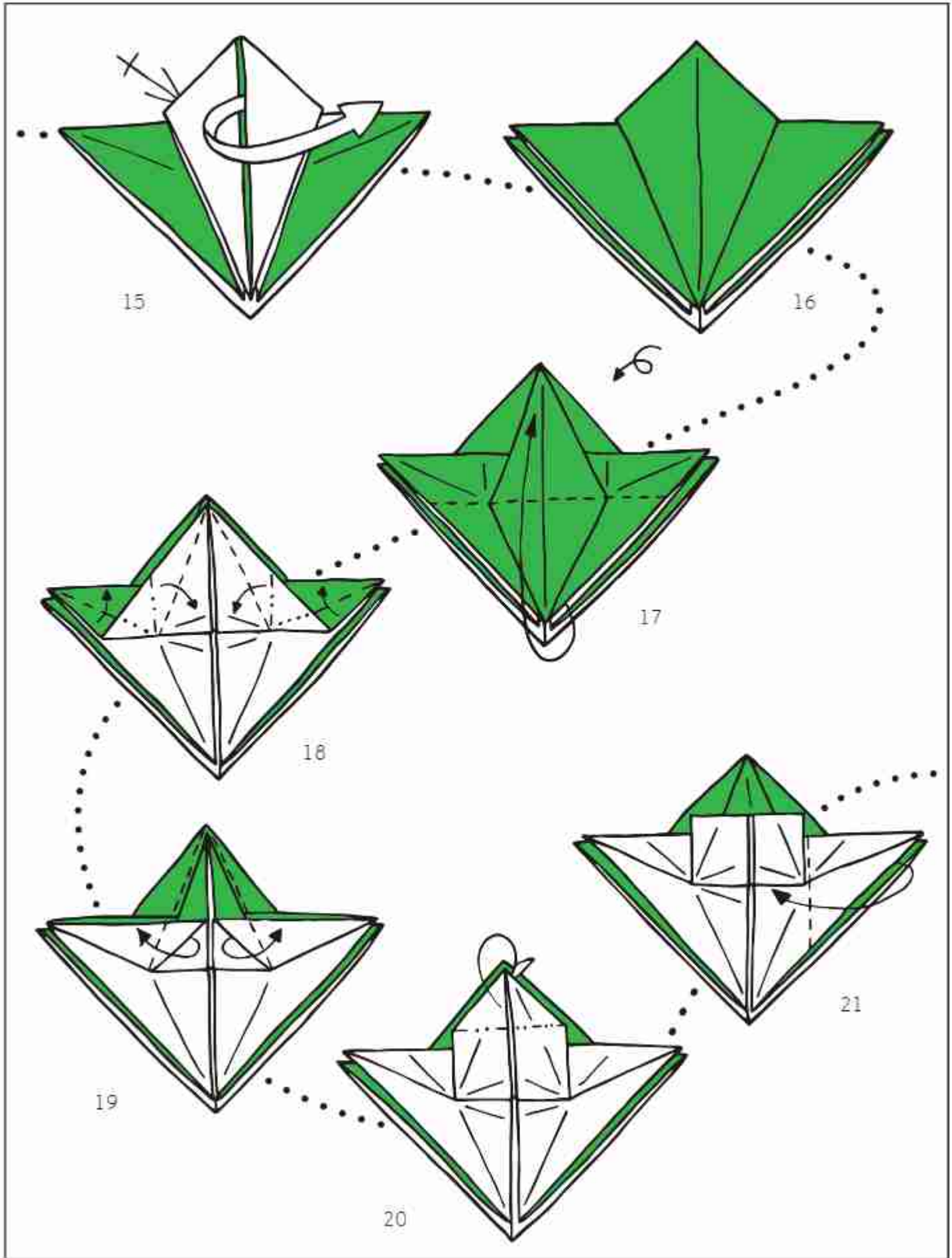

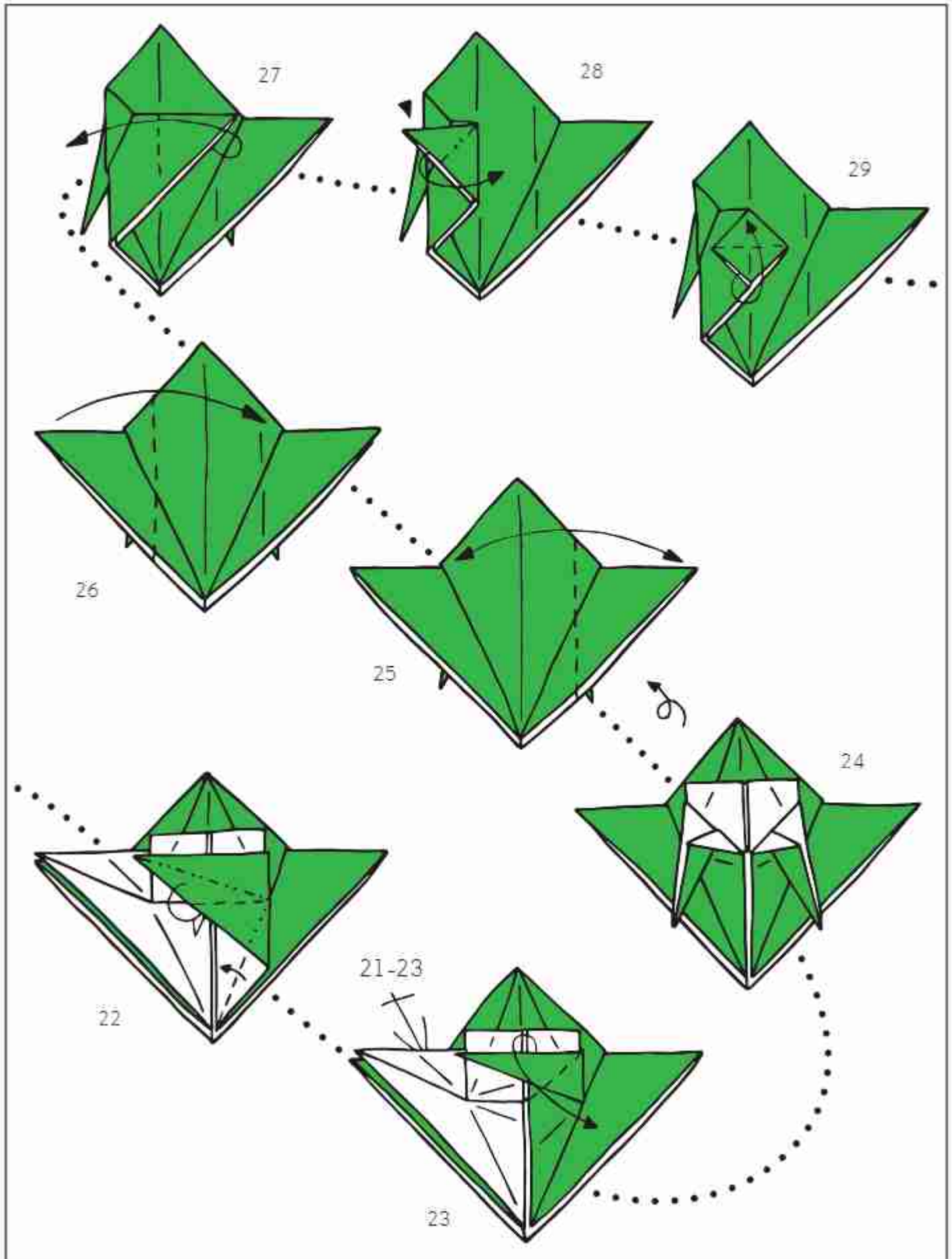

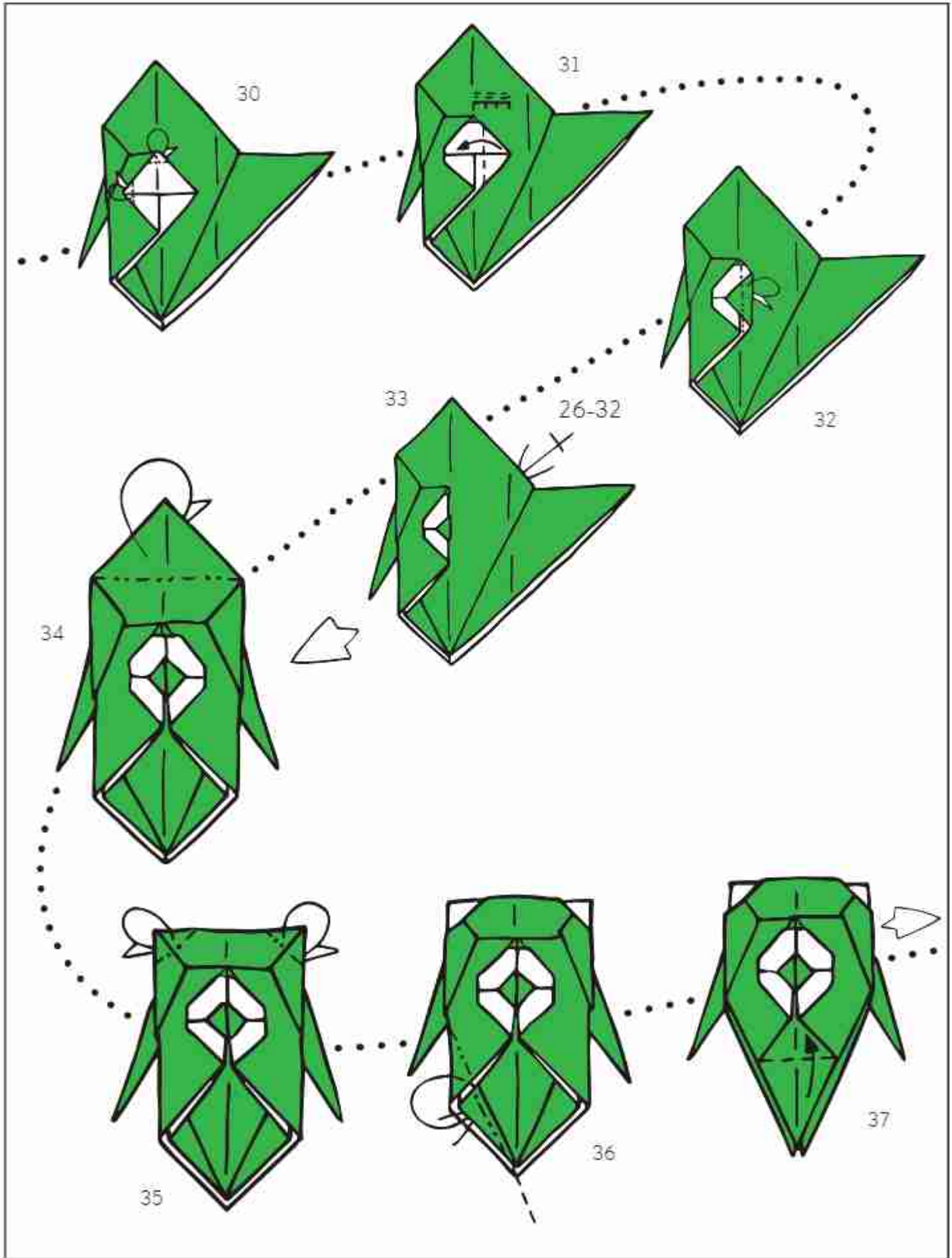

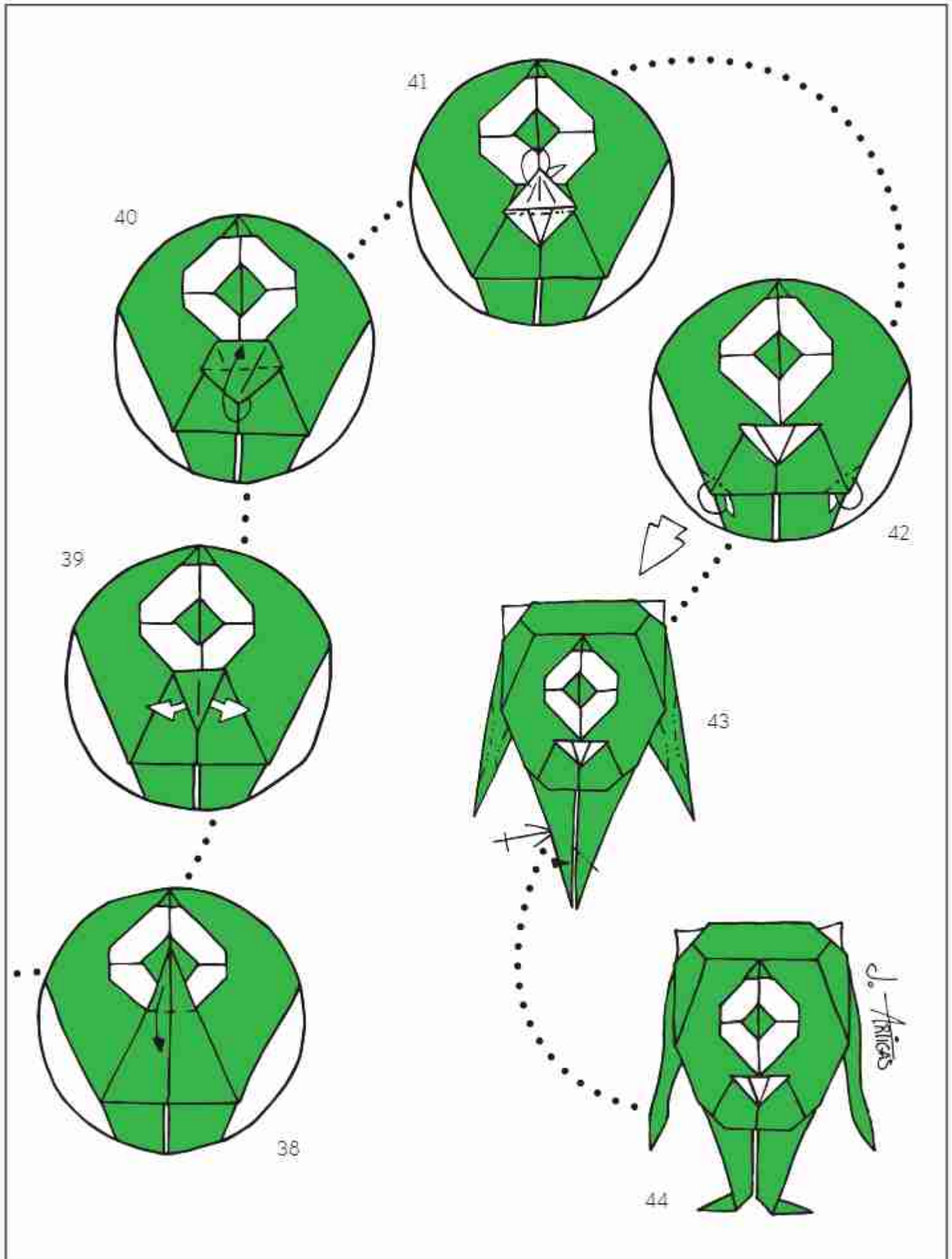

Bevy of Bats

Intermediate

Viviane Bertly

©2021 - France

Chauve-souris sur un carré

©Viviane Bertly 2021

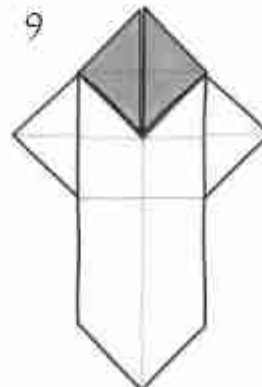
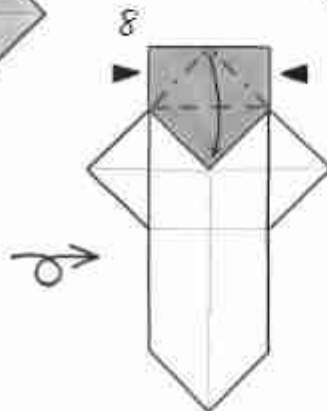
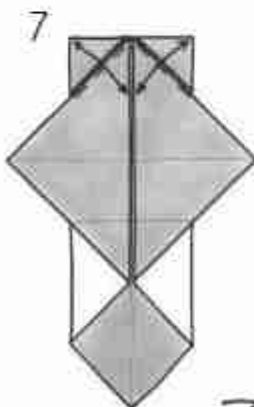
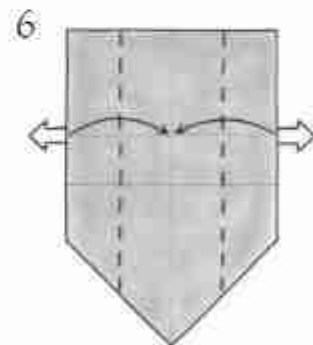
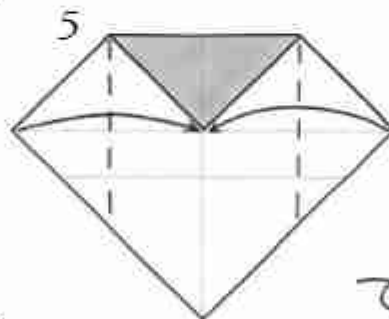
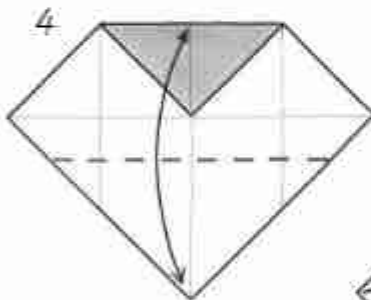
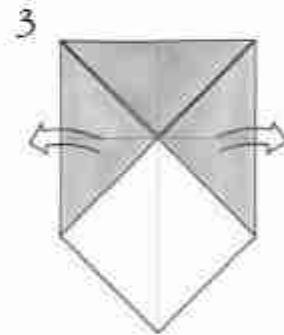
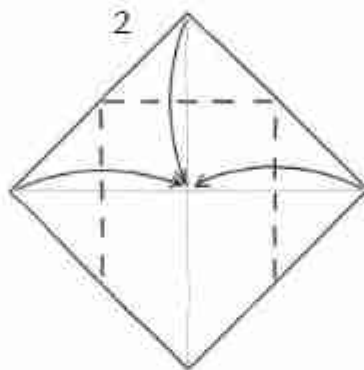
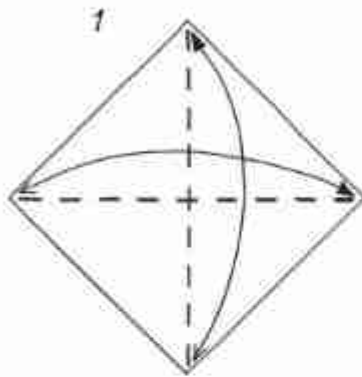

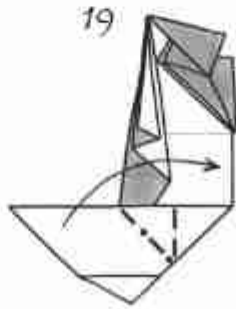
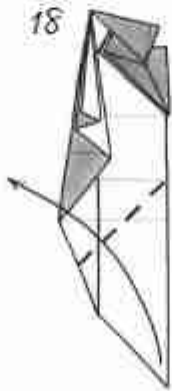
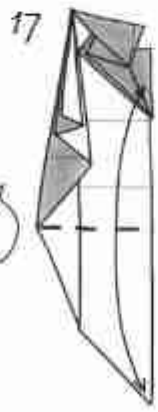
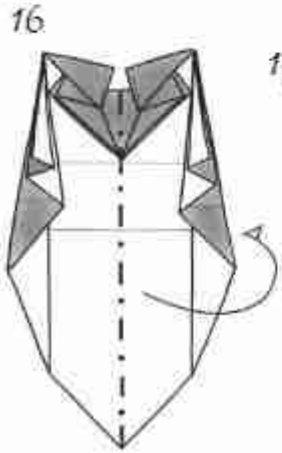
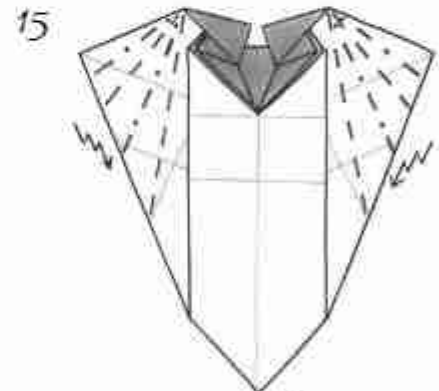
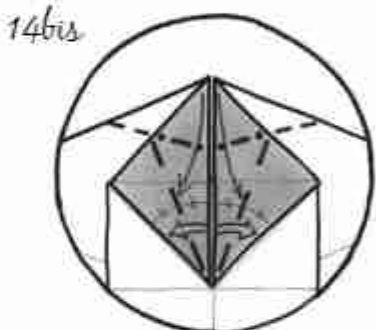
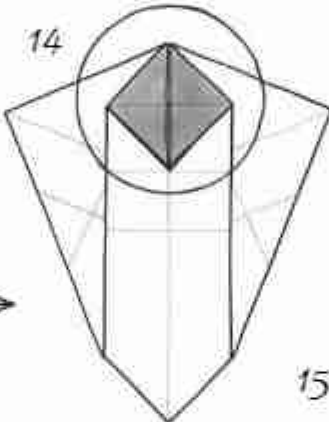
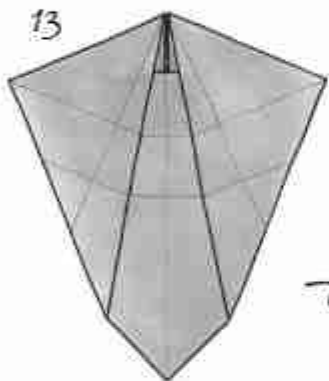
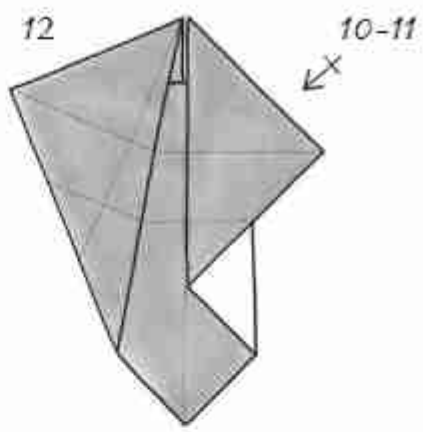
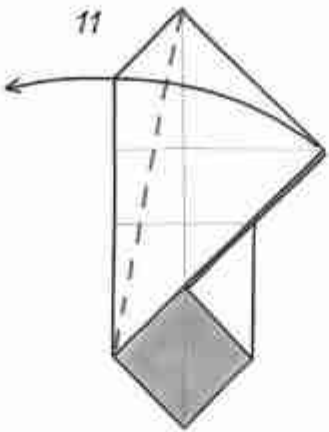
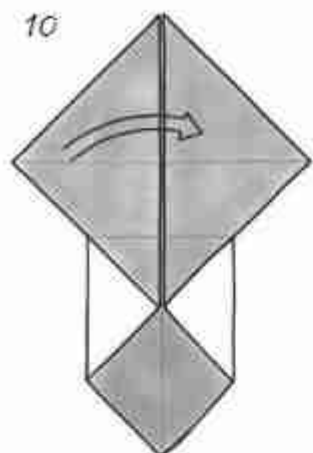

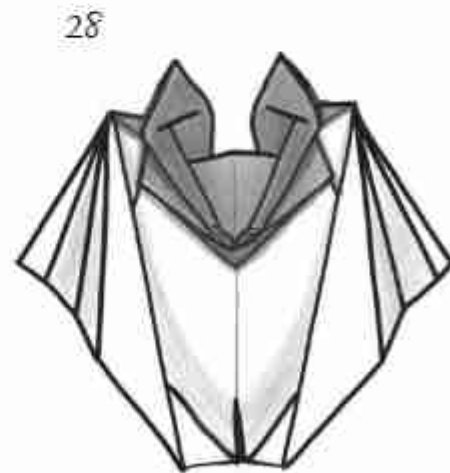
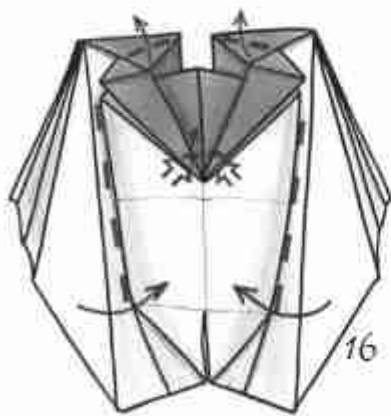
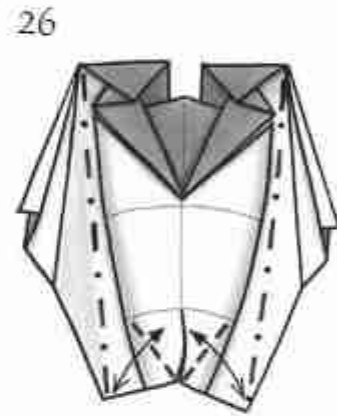
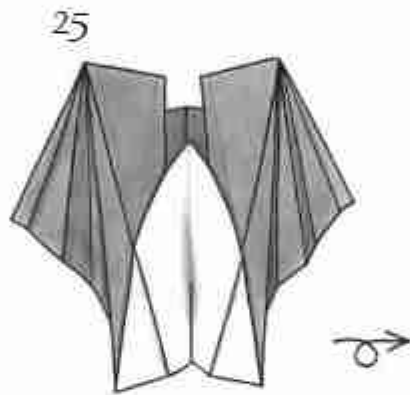
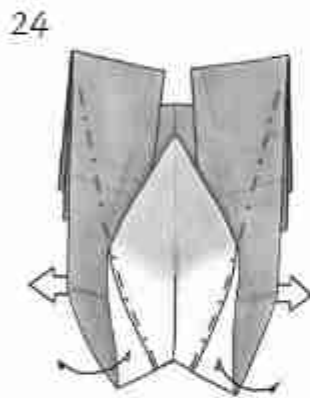
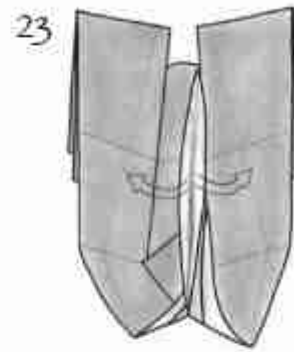
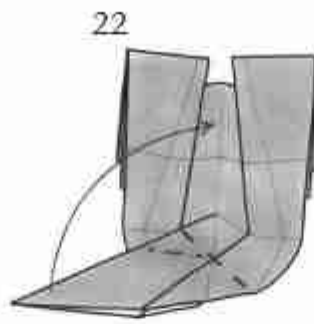
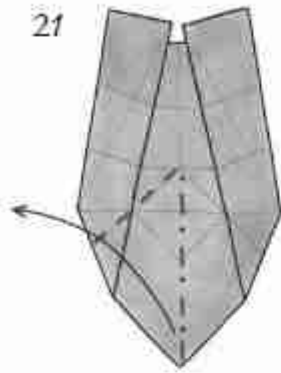

Chauve-souris sur un pentagone

©Viviane Berty 2021

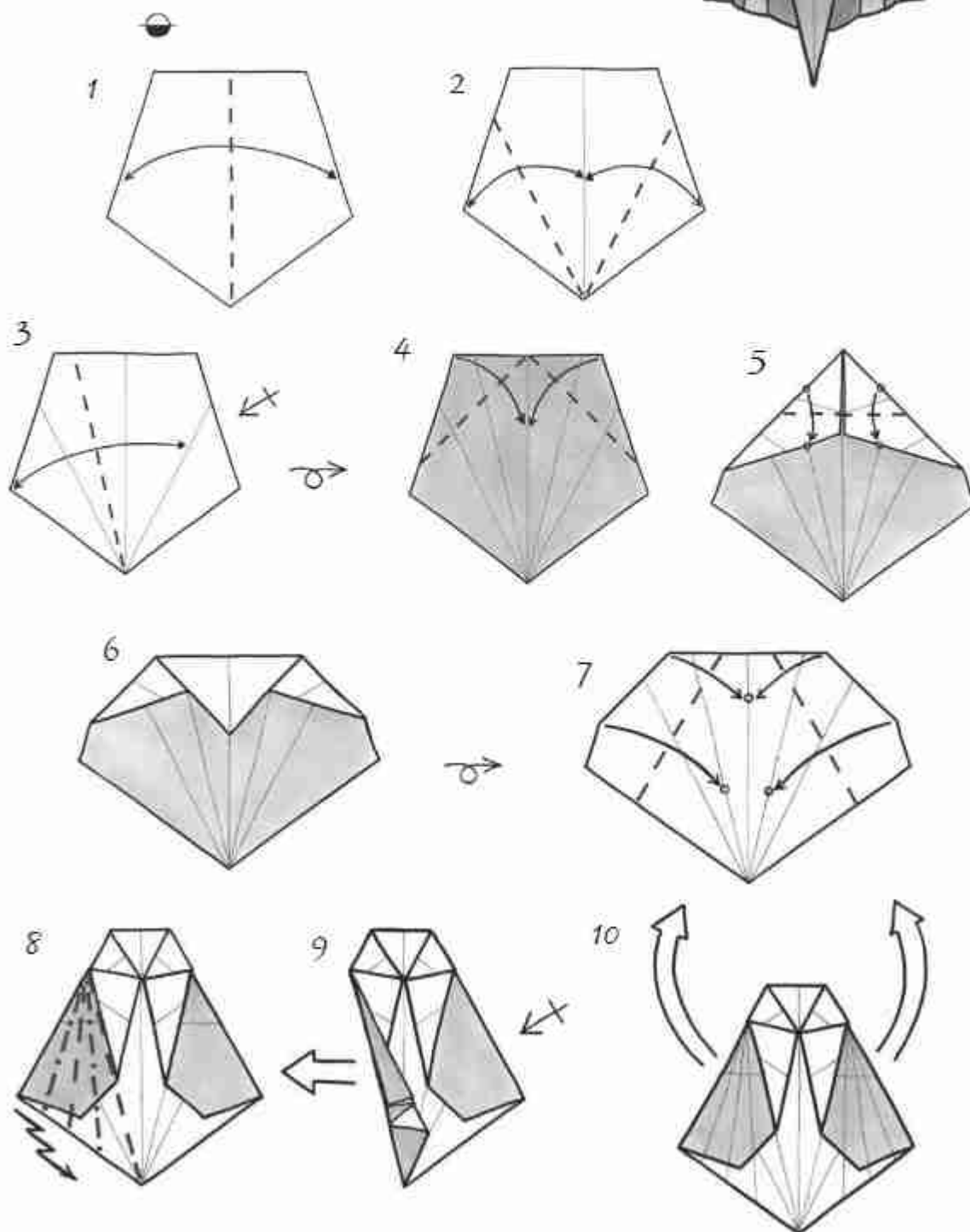

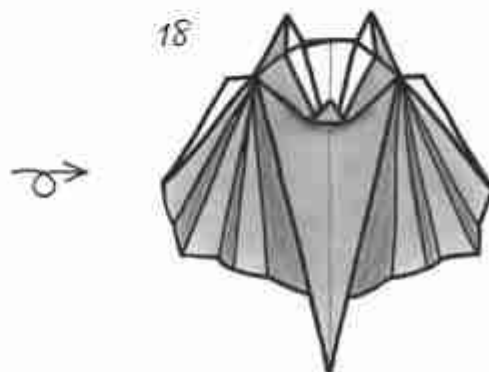
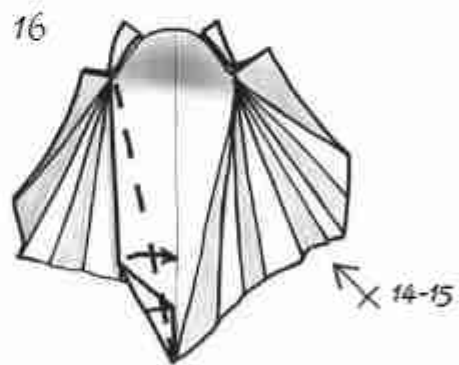
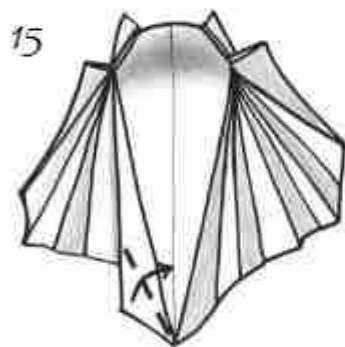
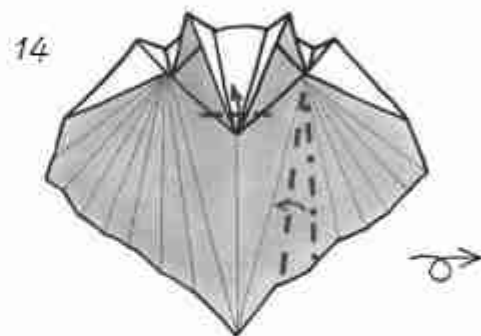
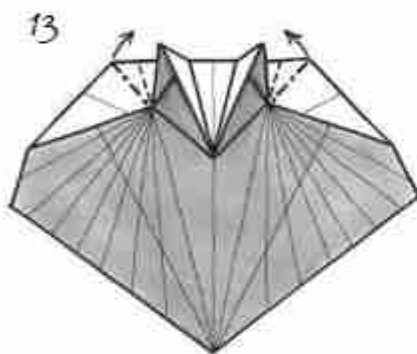
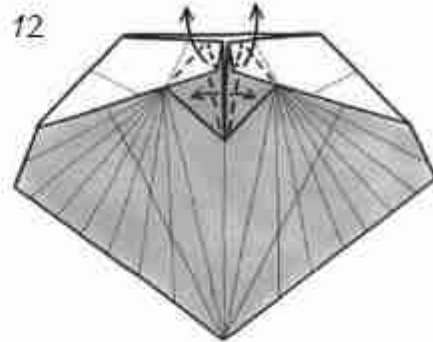
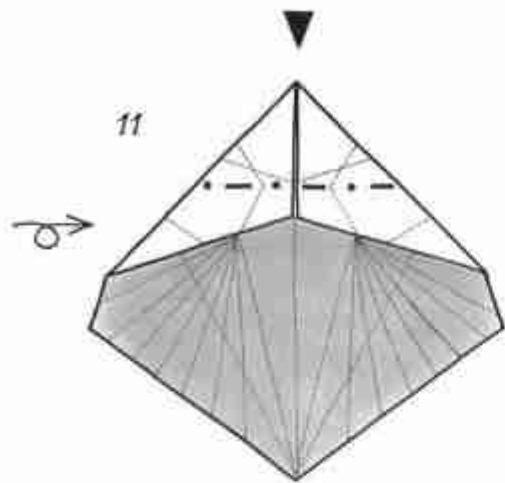

Chauve-souris

©Viviane Berty 2021

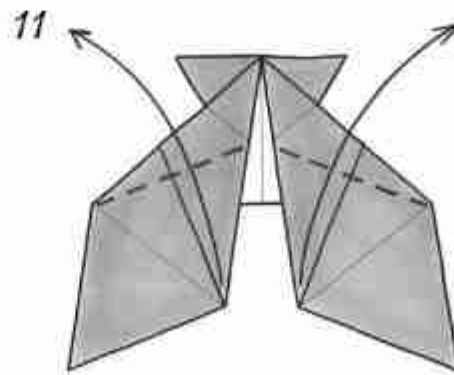
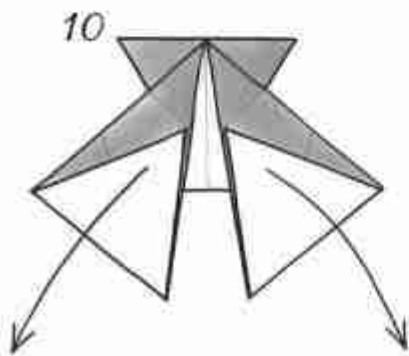
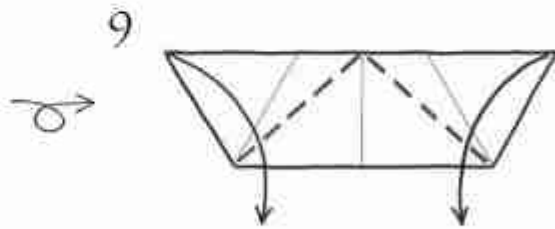
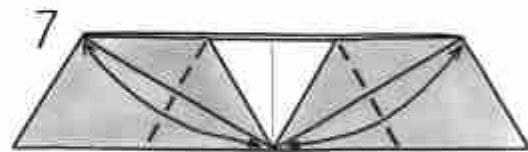
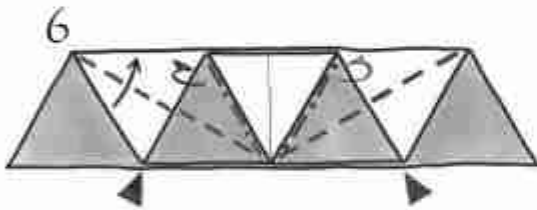
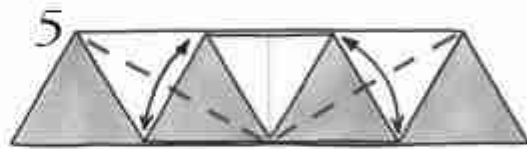
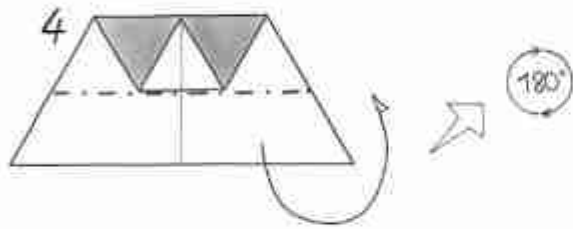
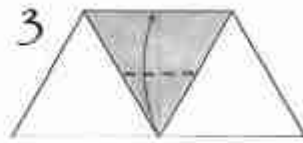
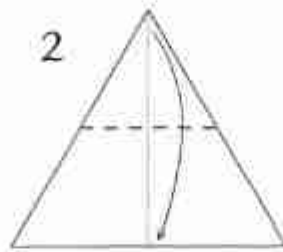
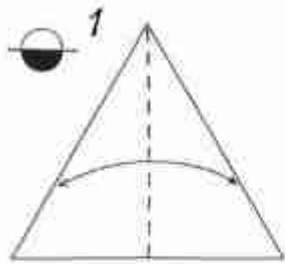

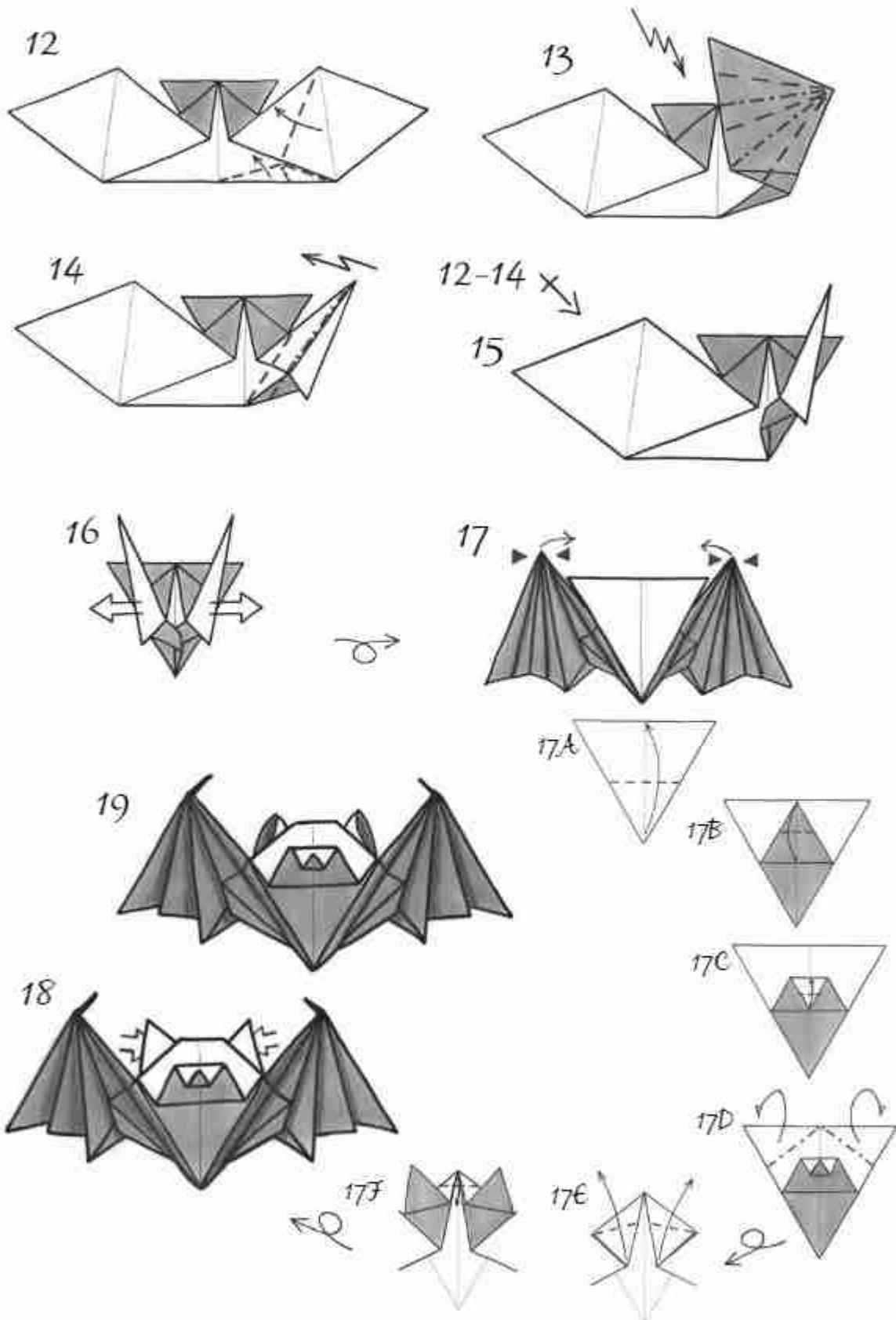

Chauve-souris sur un triangle rectangle
©Viviane Bertly 2019

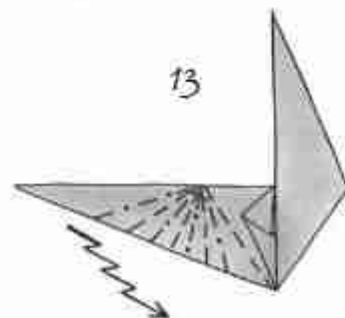
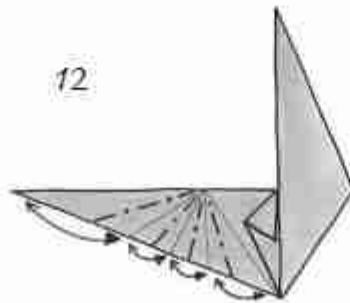
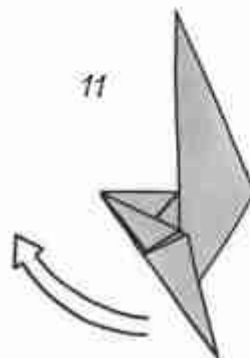
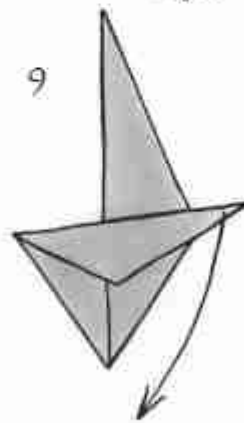
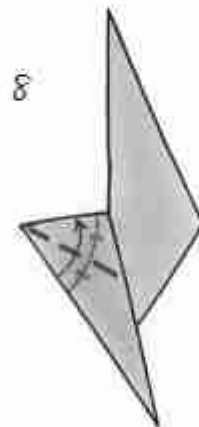
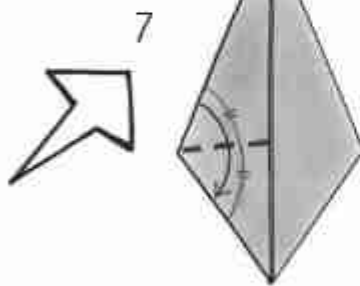
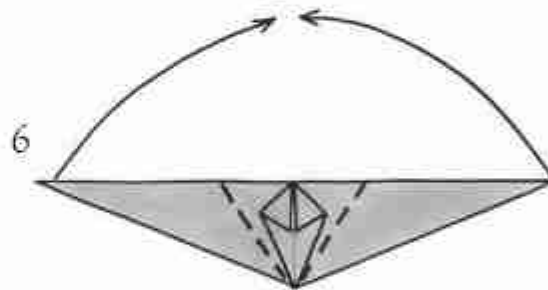
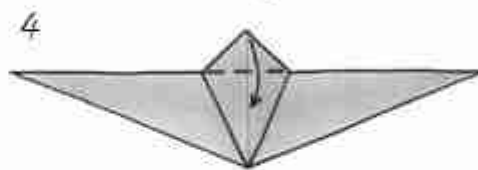
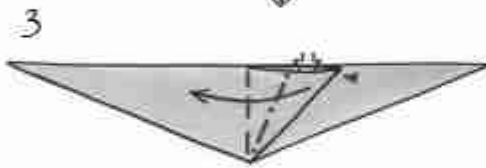
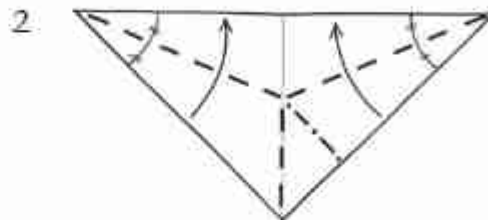
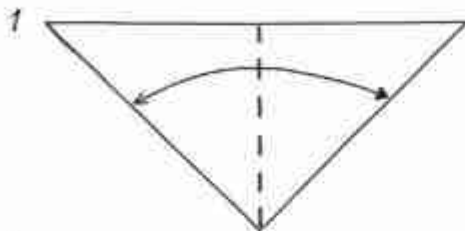

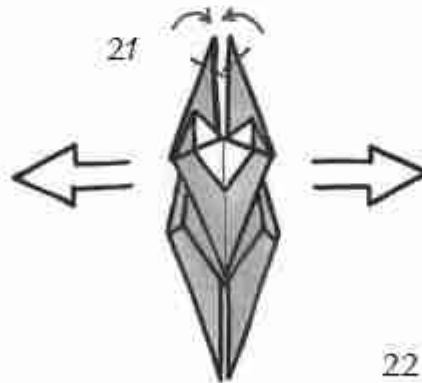
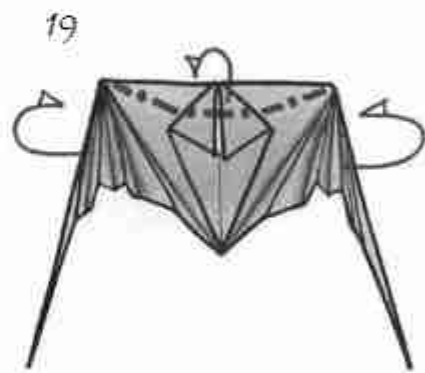
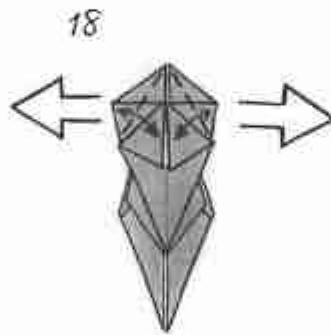
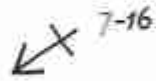
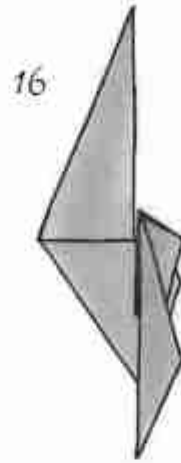
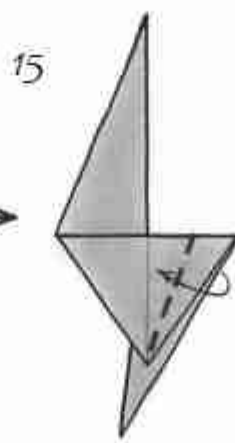
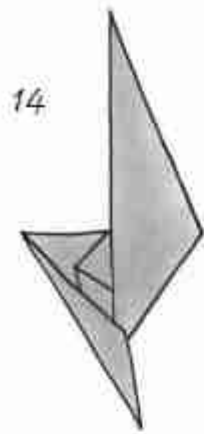

22



Rhinolophe

©Viviane Berty 2021

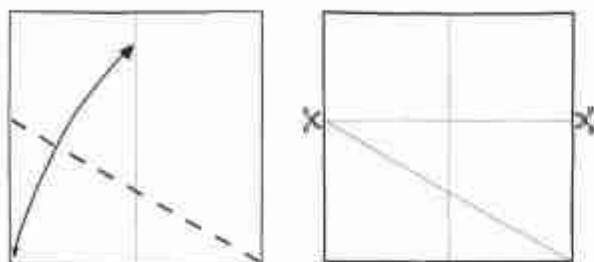
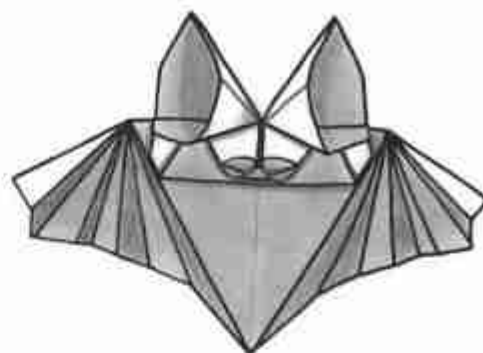

Extraire un rectangle au format $1 \times \sqrt{3}$

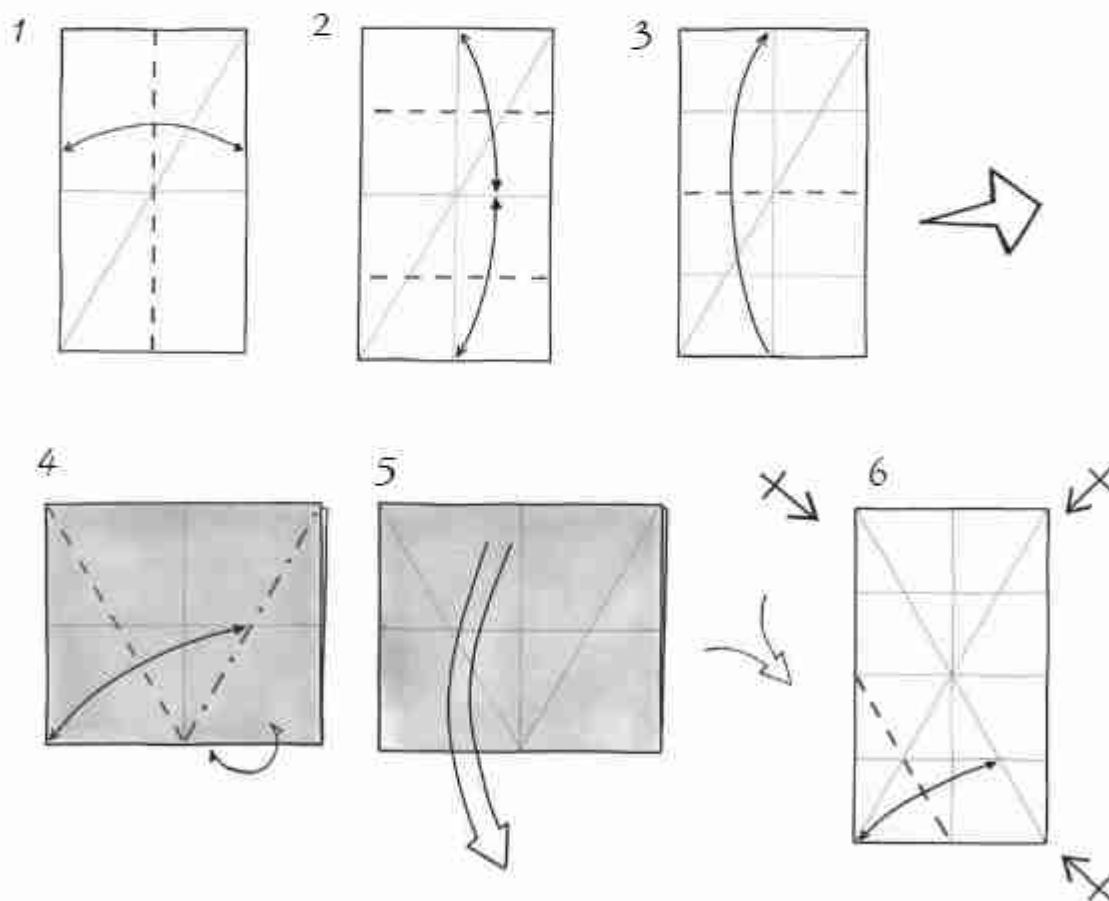

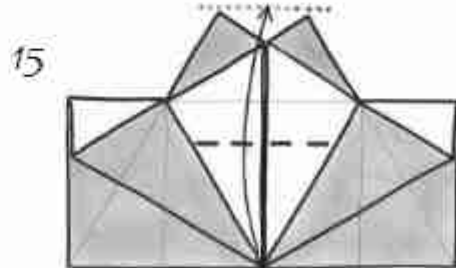
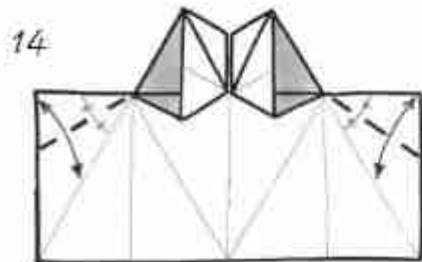
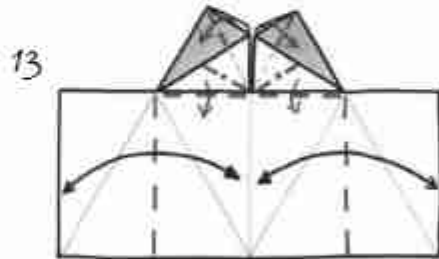
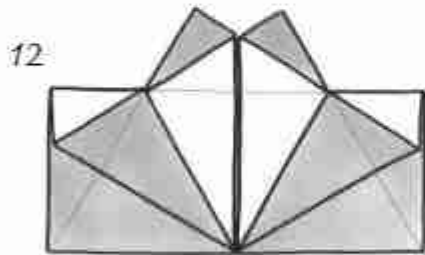
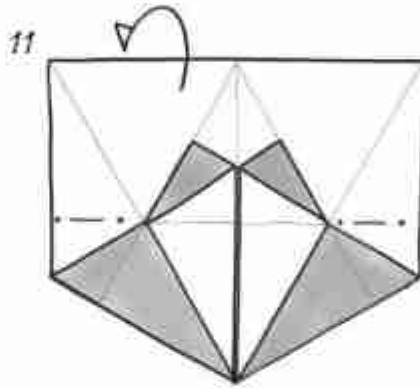
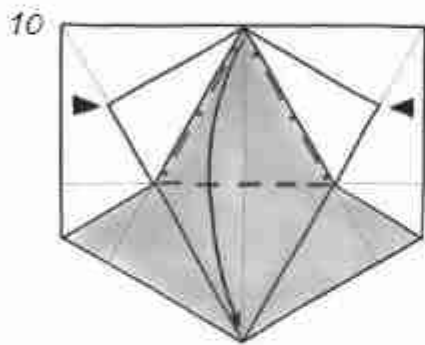
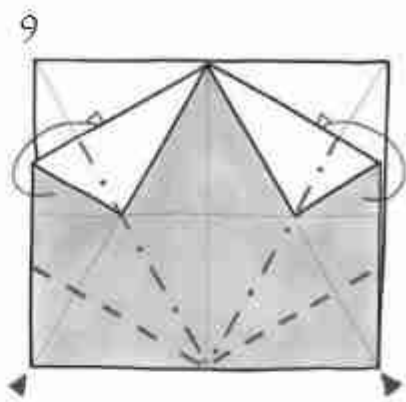
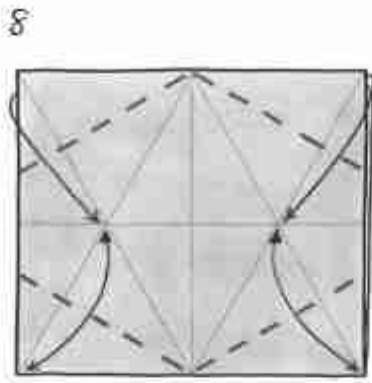
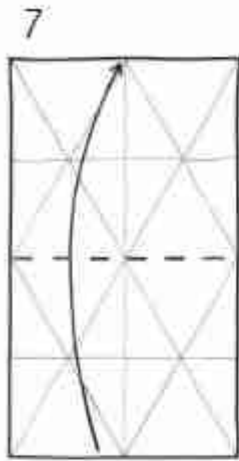

16

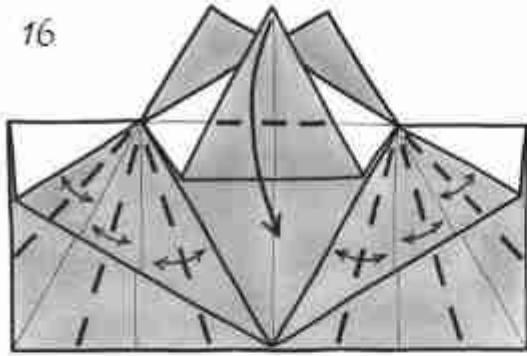

17

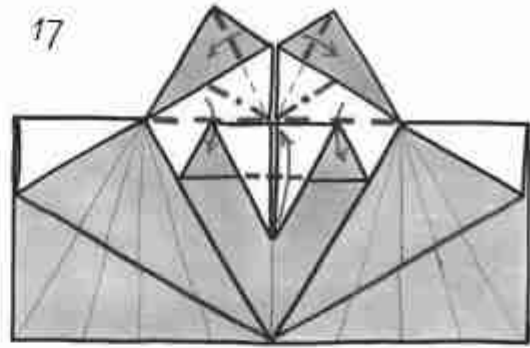

18

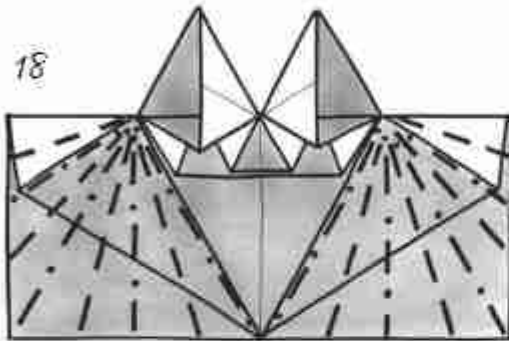

19

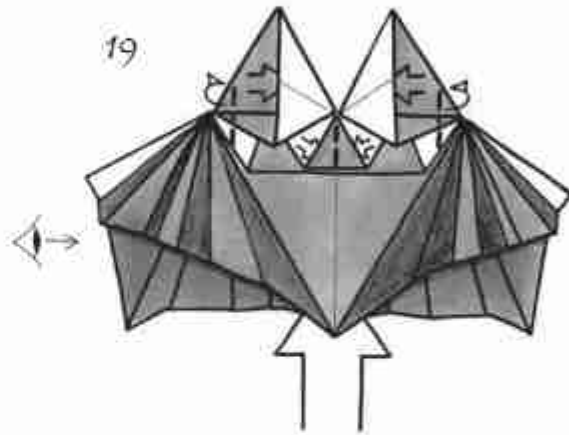

20

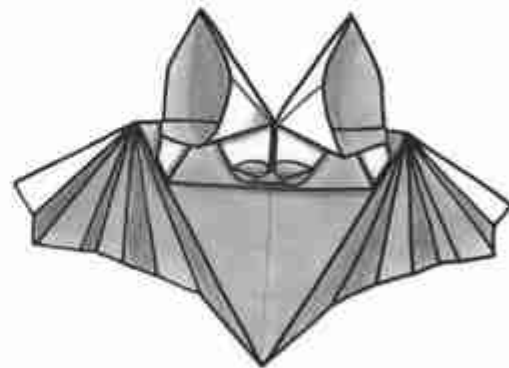

→

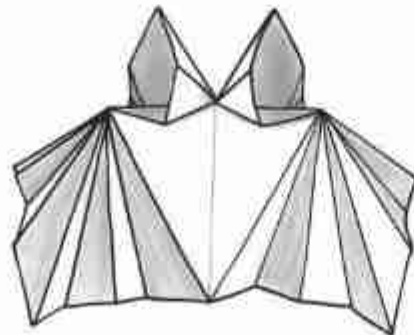

Tiny Pentagonal Tato-box

Christiane Bettens

©2020 - Switzerland

High Intermediate

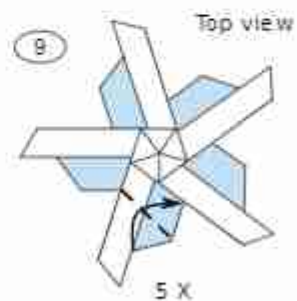
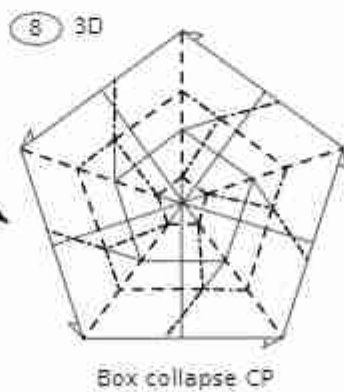
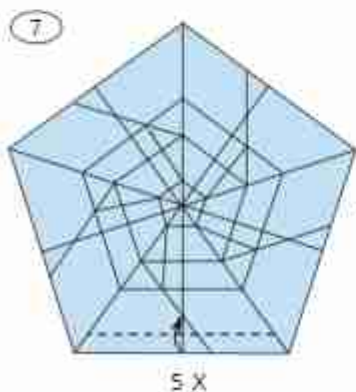
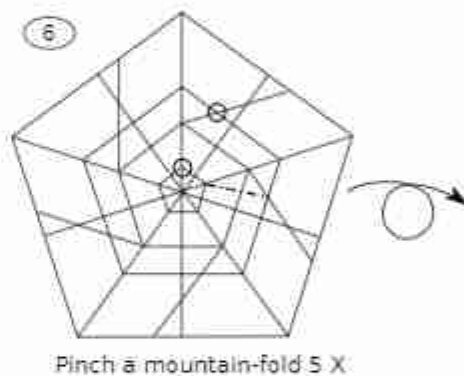
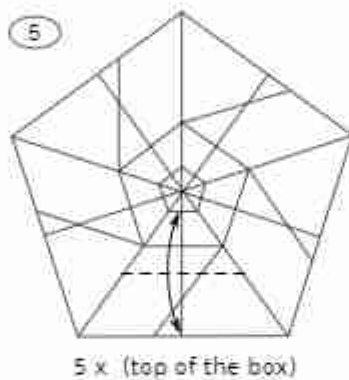
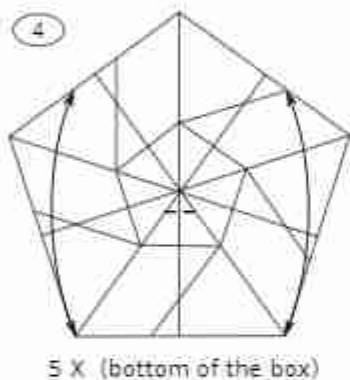
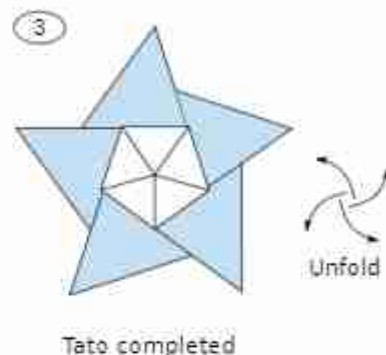
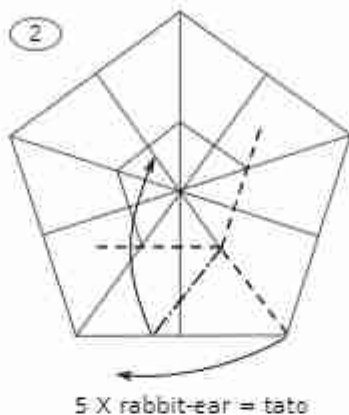
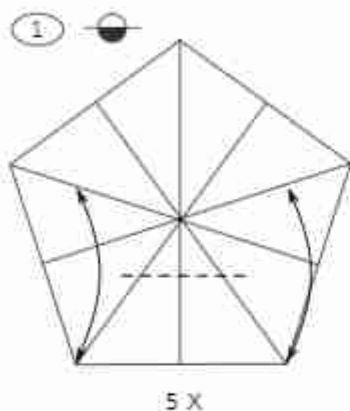

Wren

Alberto Carminati

©2022 - Italy

High Intermediate



1

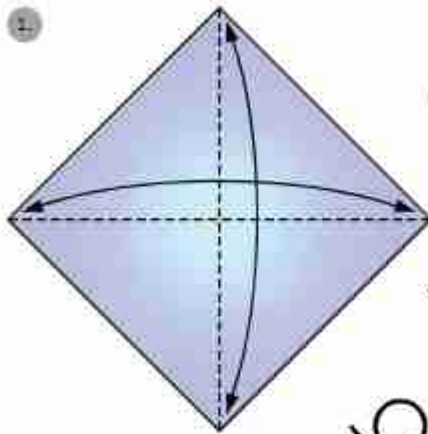

2

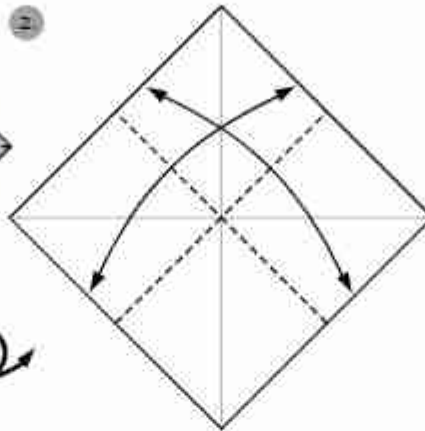

3

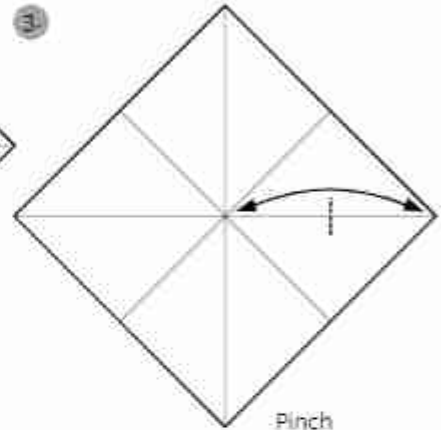

4

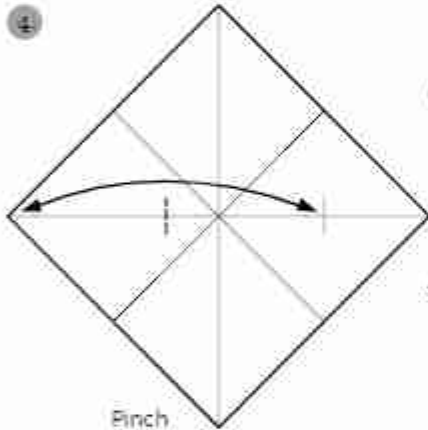

5

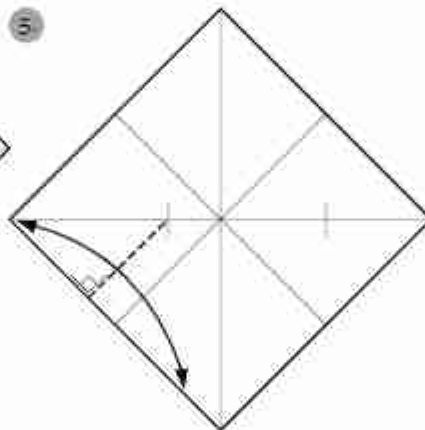

6

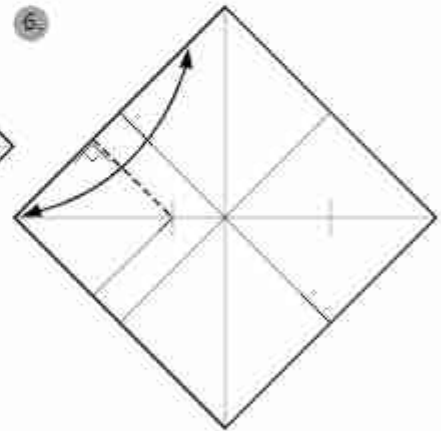

7

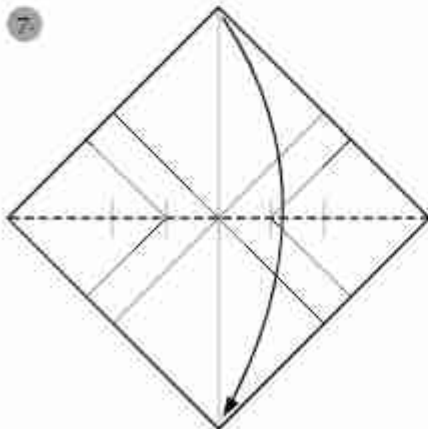

8

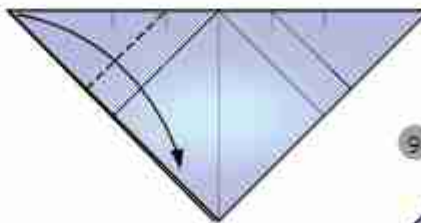

9

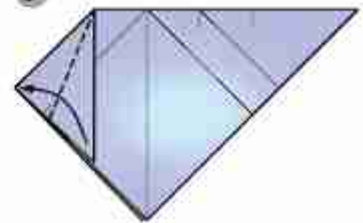

10.

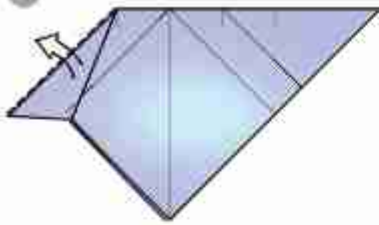

Turn two layer over

11.

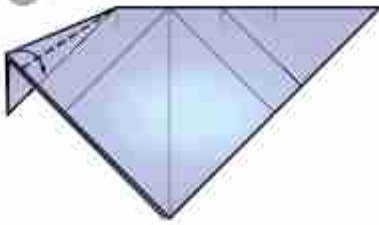

Let the paper behind flip around

12.

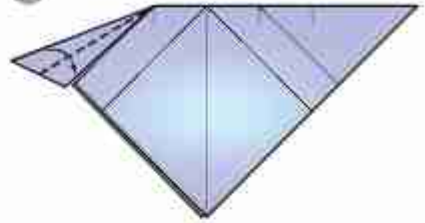

13.

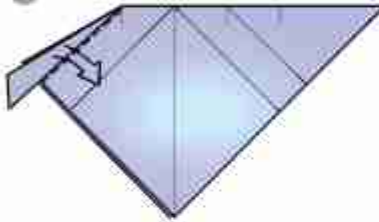

Turn two layer over

14.

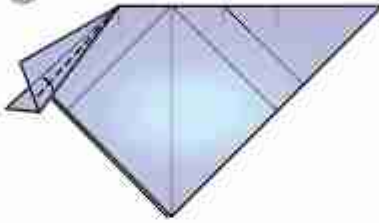

Let the paper behind flip around

15.

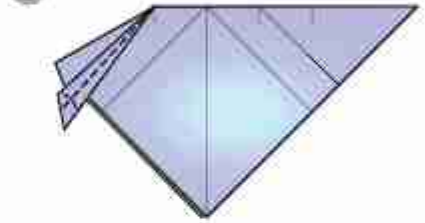

16.

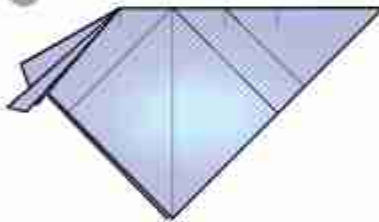

Unfold to 8.

17.

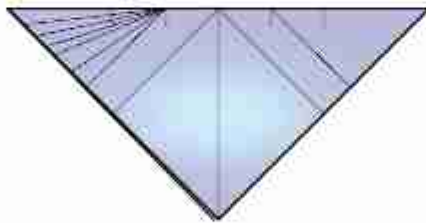

Repeat 8. to 16, symmetrically

18.

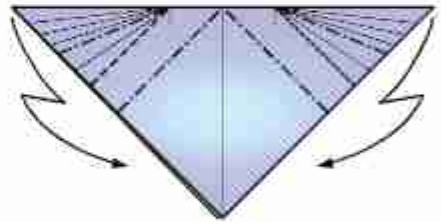

Crimp

19.

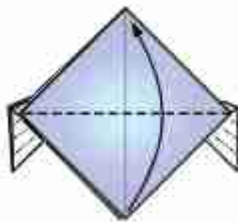

20.

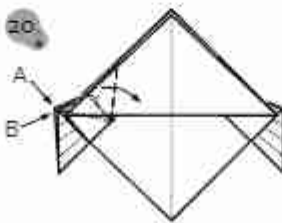

Swivel-fold bringing edge A to edge B

20.

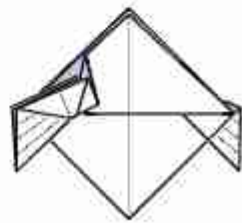

Result

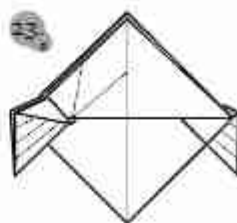
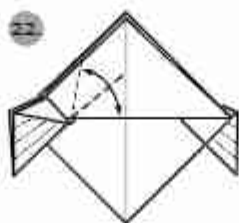
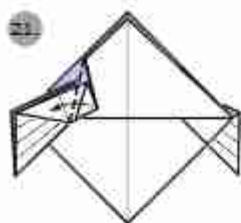

Repeat 20 to 22 symmetrically

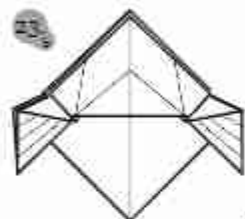

Result

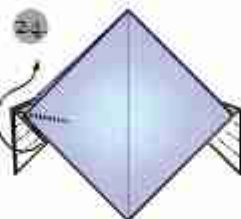

Inside reverse-fold

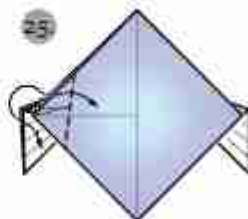

Open incorporating an inside reverse fold

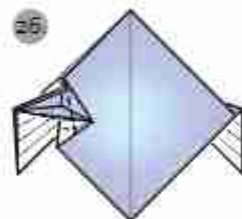

Repeat 24 to 27 symmetrically

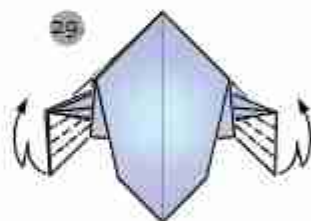
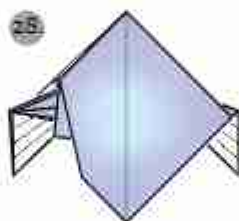
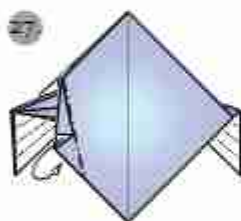

Crimp along the creases

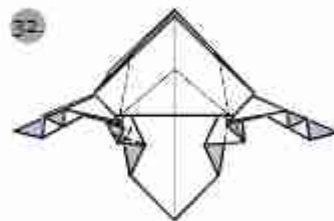
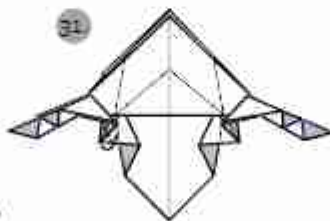
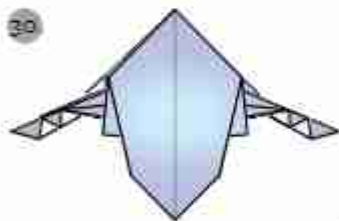

Repeat 31 to 32 symmetrically

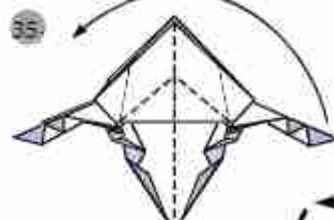
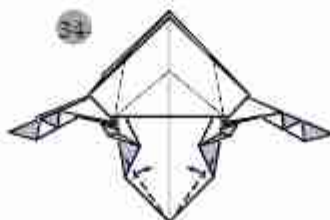
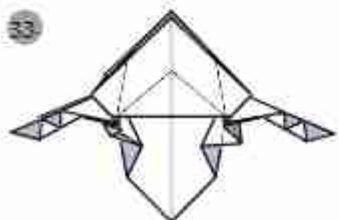

Close up the model



36

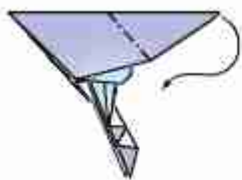

Inside reverse-fold

37



Inside reverse-fold

38

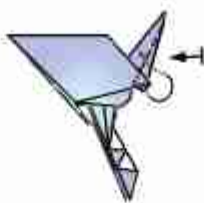

Swivel-fold

39



Outside reverse-fold
without folding the
innermost layer

40

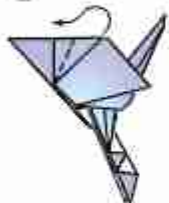

Outside reverse-fold

41



Pull paper out

42



Closed sink

43



44

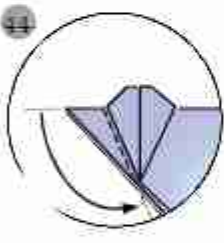

Squash

45

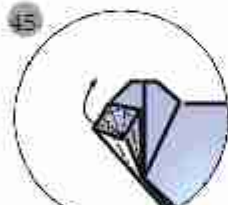

Petal-fold

46

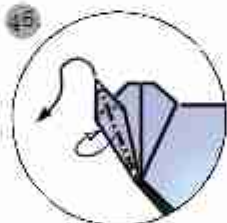

Swivel incorporating
a reverse fold

47

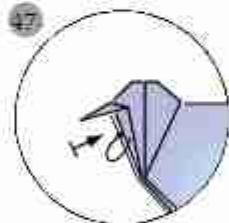

Hide the paper
inside

48



Sink

49



Pocket two flaps
unfolding 21

50



Fold firmly

51



Multiple inside
reverse-folds

52



53



Invert a crease following the pattern

53



Detail, mind the marked points

54



Repeat 3 other times

54



55



56

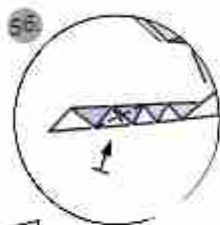

57

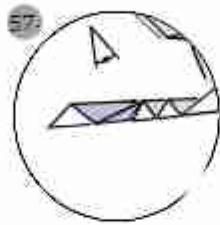

58



59



60



Flatten the creases up to the edge created at 56

61

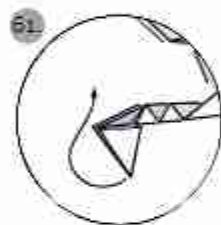

62

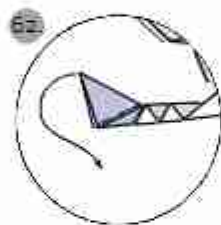

63

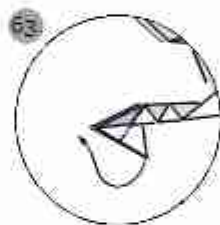

64

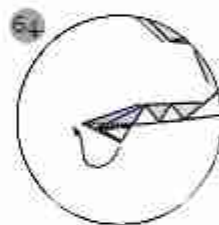

Series of inside reverse folds

65

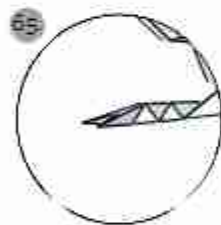

66



Repeat 50. to 64. on the other leg

Wrap first layer around to lock the leg

67



68

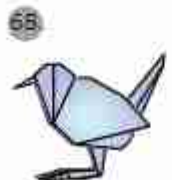

Shape the model

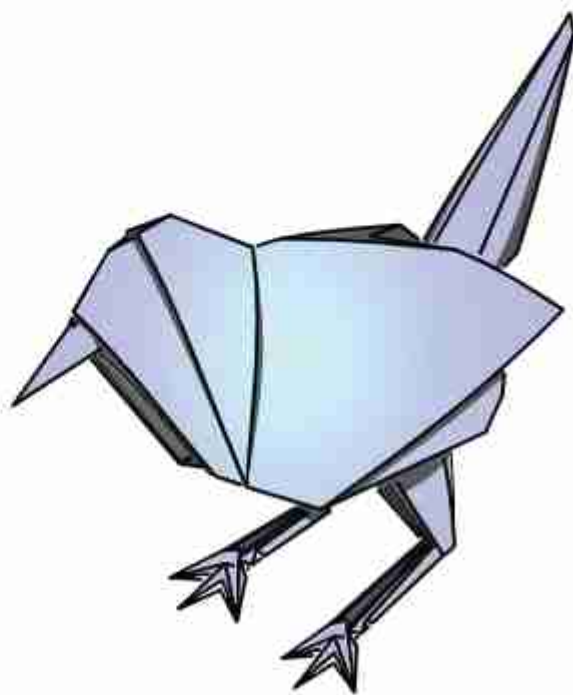

Koala

Intermediate

Steven Casey

©1992 - Australia

Paper: Grey Kami or art paper

Size: At least 15 x 15 cm square

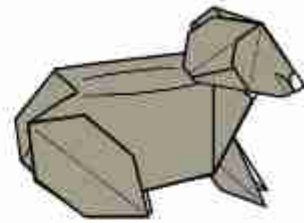

1

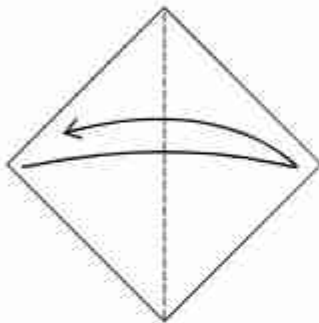

Fold then unfold

2

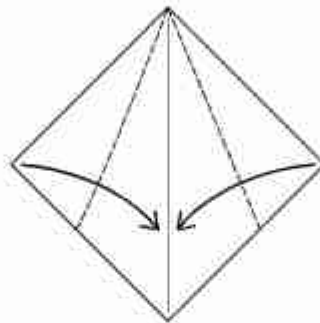

Fold top edges to the center crease.

3

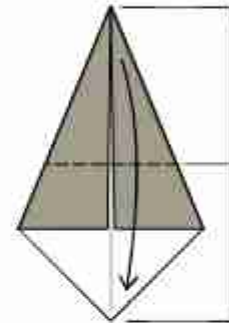

3. Fold the top point down to the bottom corner.

4

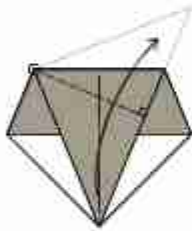

Valley the near flap up beginning at the corner. The right edge folds along itself.

5

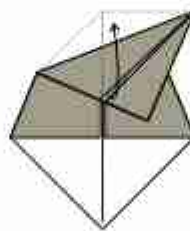

Pull out trapped layers.

6

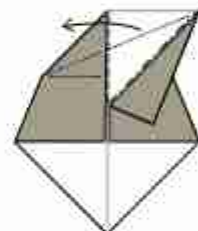

Squash fold.

7

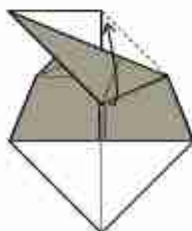

Pull out trapped layers.

8

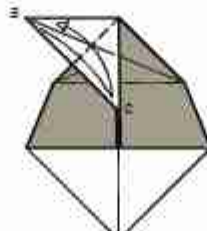

Bring the two points together with a valley. Unfold.

9

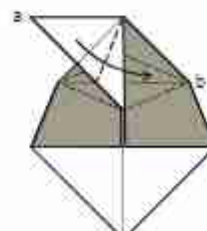

Fold the left corner 'a' over to the side corner 'b'.

10

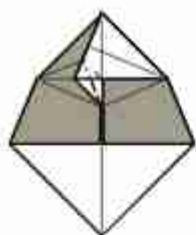

Reverse fold.

11

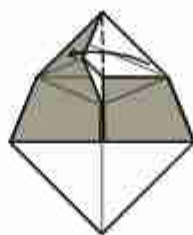

Fold flap over.

12

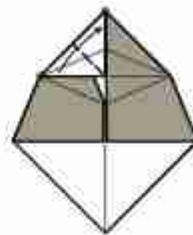

Fold the flap up so the two point align.

13

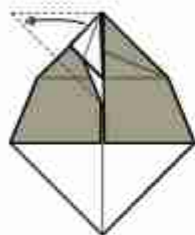

Unfold to step 9.

14

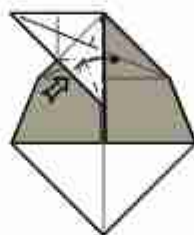

Collpase using existing creases.

15

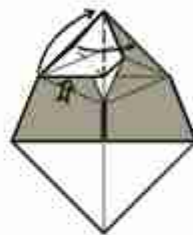

Squash fold.

16

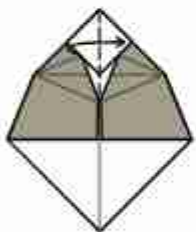

Valley group of flaps over to the right.

17

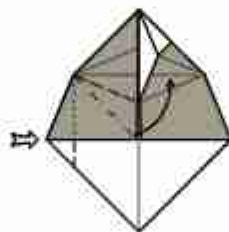

Swivel fold.

18

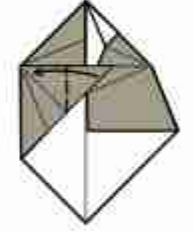

Valley tip over to the edge.

19

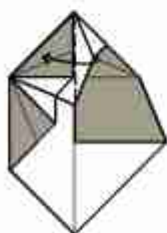

Valley group of flaps over to the left.

20

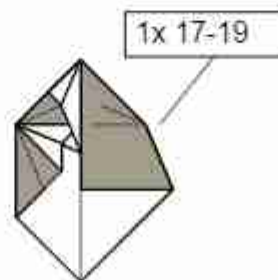

Repeat steps 17 to 18.

21



Fold a single layer over to the right.

22



For the small square, fold the top corner down to the bottom corner.

23

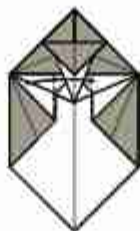

Fold flap in the opposite direction.

24



Connect the two points with a valley fold, then unfold.

25

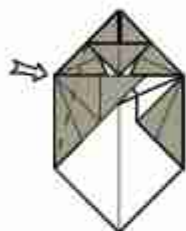

Close sink.

26



Fold flap over on existing crease.

27

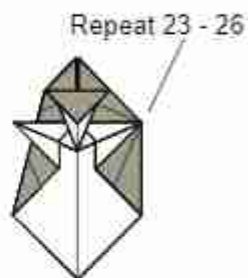

Repeat steps on opposite side.

28



Fold corner over to the opposite side.

29



Precrease.

30



lift corner up and to the side.

31



Push in greyed area, then fold valleys to flatten. Bring the corner back to the side.

32



Detail of step 31.

33



Fold single flap over.

34



Pull out hidden corner.

35



Repeat for other side.

36

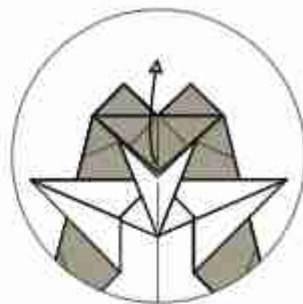

Lift near layer.

37



Open sink corner.

38



Fold corners into the middle.

39

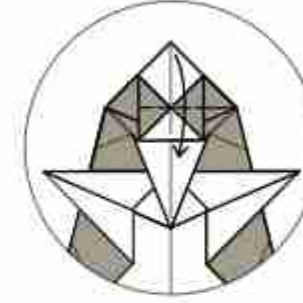

Fold flap down.

40



Fold corners behind.

41

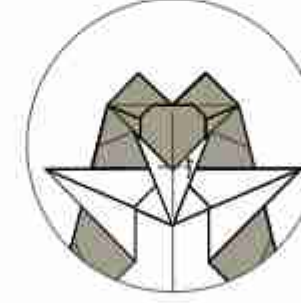

Fold the tip of the corner up.

42

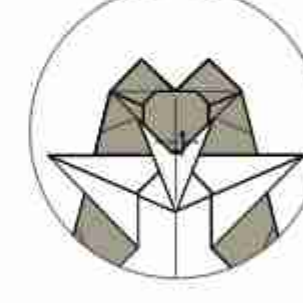

Fold over again.

43

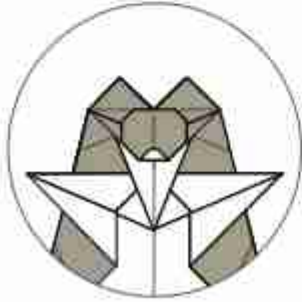

Result.

44

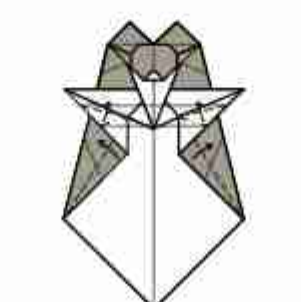

Swivel.

45

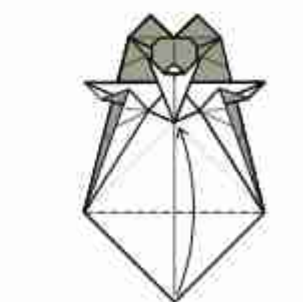

Valley

46

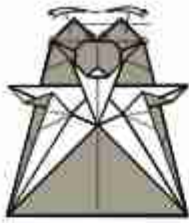

Pinch crease

47

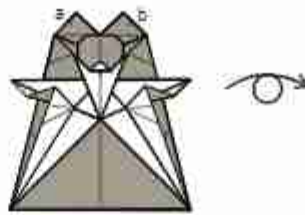

48

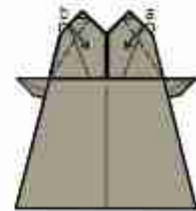

Squash fold.

49

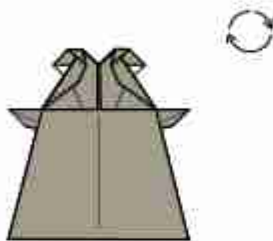

Rotate 90 degrees clockwise.

50

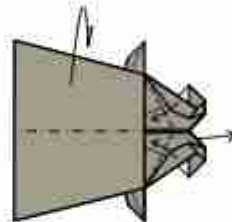

Fold ears back and bring head forward, while folding the top section behind.

51

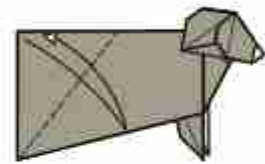

Precrease angle bisector.

52

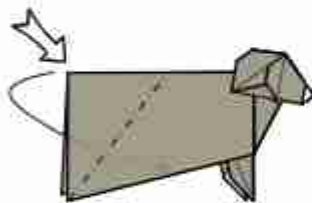

Reverse fold.

53

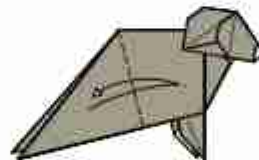

Fold along the hinge, then unfold.

54

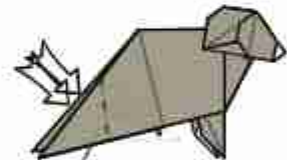

Reverse fold both flaps. Note position of flaps.

55



Open out along the hinge.

56



Sink top and bottom corners in front and behind.

57

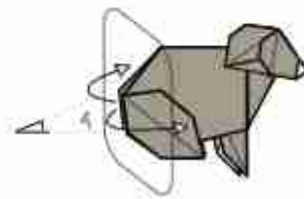

The next step will focus on the view from arrow A.

58

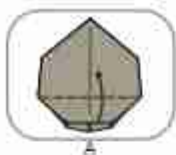

Fold the lower edge up.

59

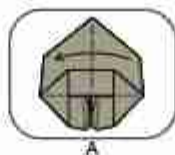

Then bring the flaps together again.

60

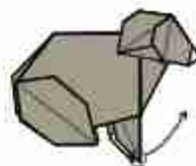

Pull arms up and forward.

61

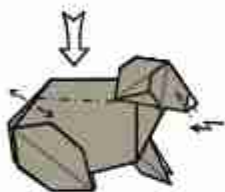

Push down and spread top layers. Crimp to form the nose and suggest eyes.

62



Fold the tips of the ears under.

63

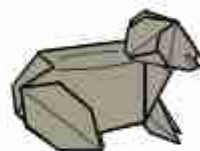

Complete. Shape to taste.

Dancing Penguin

Michele Chang

©2022 - USA

Intermediate

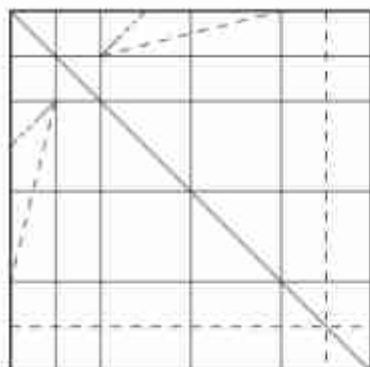

1. Precrease.

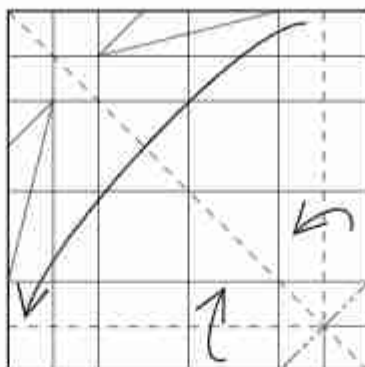

2. Rabbit ear, while folding in half along diagonal.

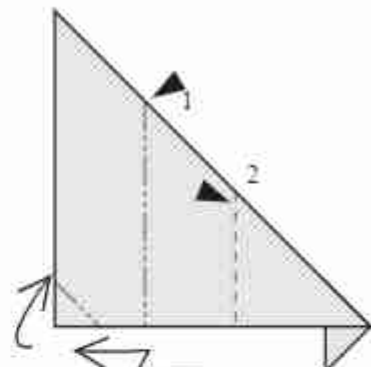

3. Reverse fold 2x. Mountain fold corner.

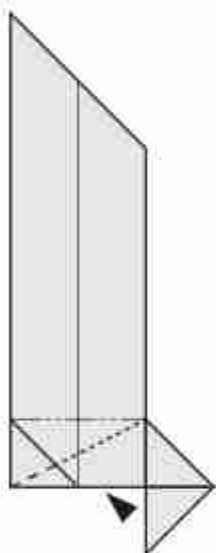

4. Reverse fold, repeat behind.

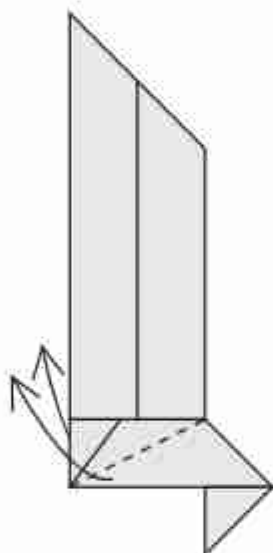

5. Outside reverse fold.

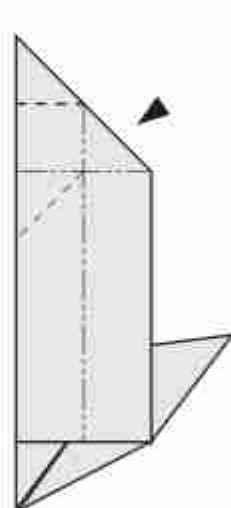

6. Box pleat head. Model is 3D.

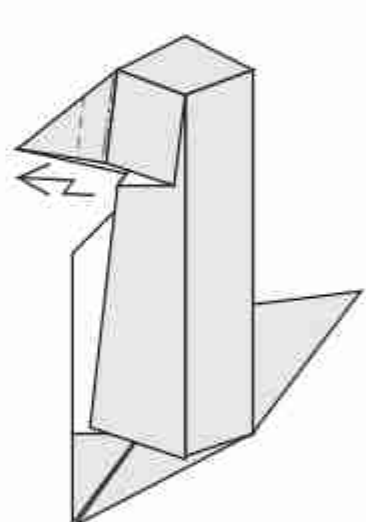

7. Crimp fold beak.

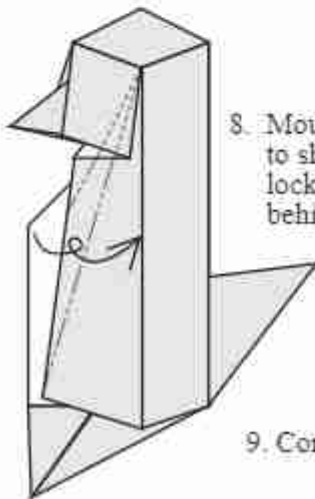

8. Mountain fold 2x to shape wings and lock head. Repeat behind.

9. Completed step 8.

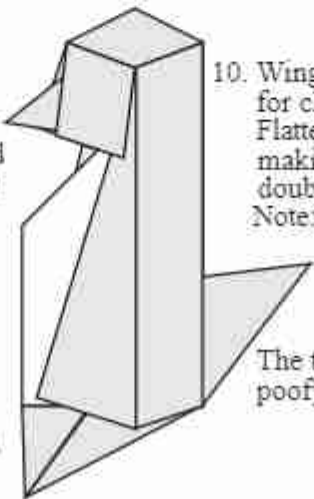

10. Wings are truncated for clarity. Flatten the feet, by making a modified double rabbit ear. Note: The diagonal line on the tummy is a bend not a true fold!!! The tummy is now poofy!

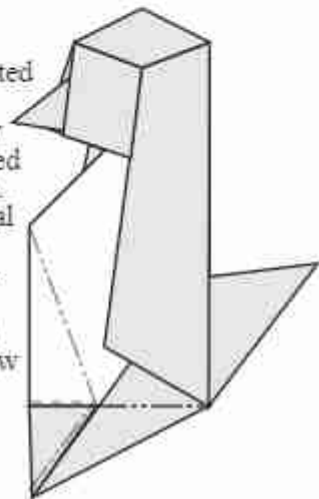

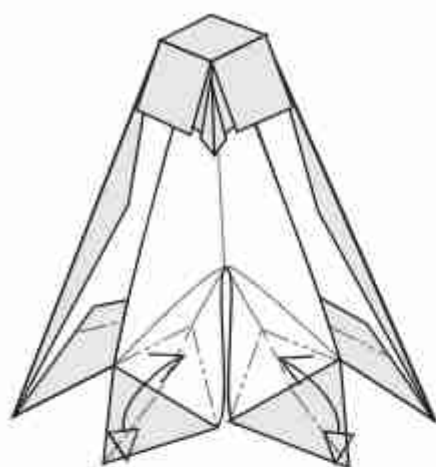

11. Double rabbit ear feet and unfold. Mountain fold the inside of the wings to lock them closer to the body.

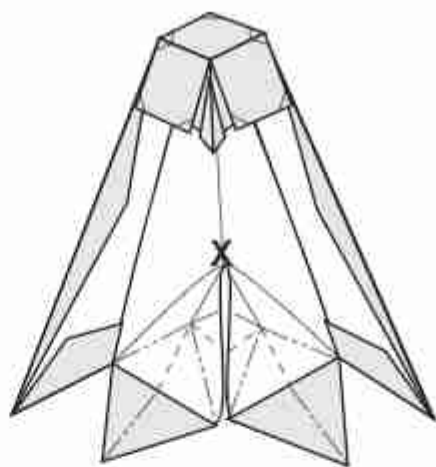

12. Push down and out on X from behind. The tummy will expand and become rounder, while the legs will become squatter. Round out the head with sinks and reverse folds.

13. Completed Dancing Penguin. Note: Try making one with a creaseless tummy!!!!

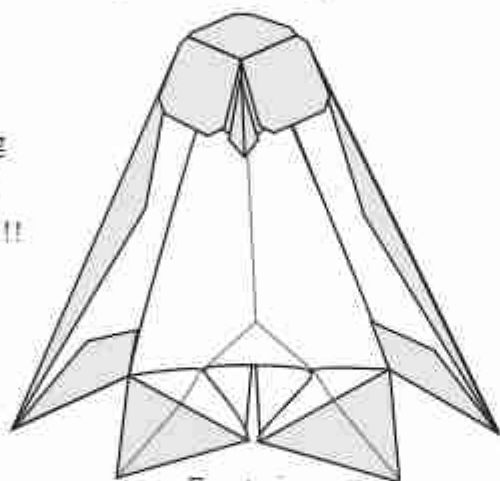

Front view

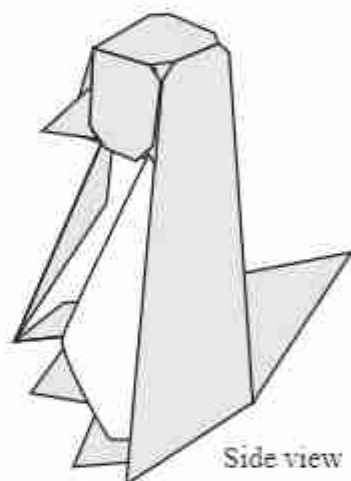

Side view

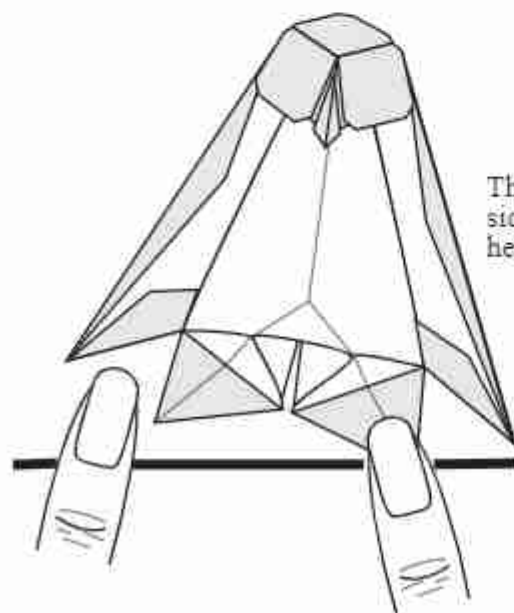

The penguin dances from side to side when you tap her feet!!

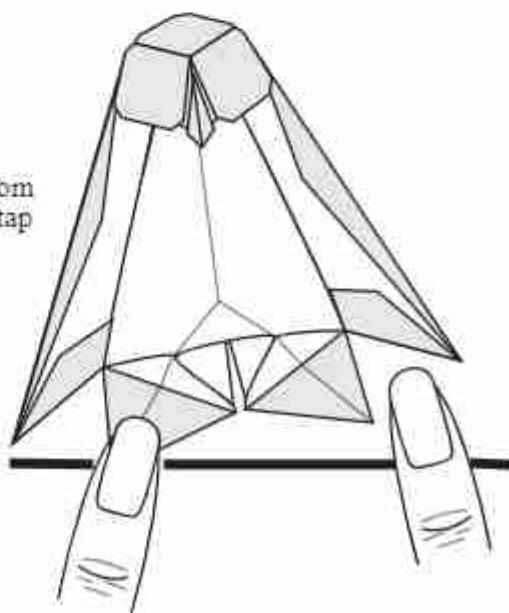

Østgardian Hippocampus

Michele Chang

©2022 - USA

High Intermediate

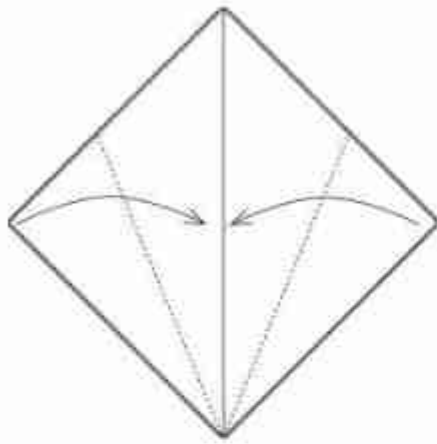

1. White side up.
Kite fold.

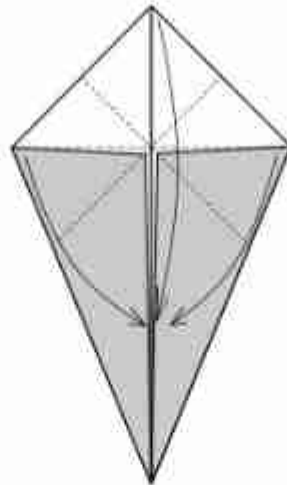

2. Preliminary fold.

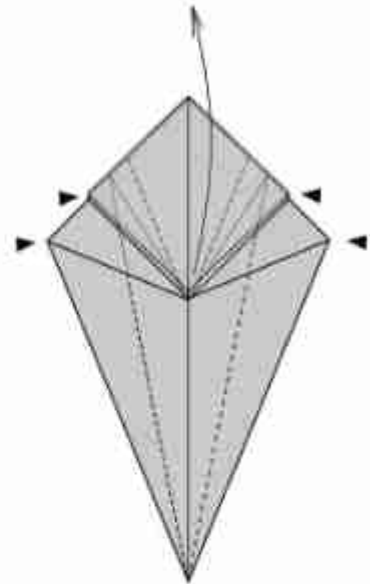

3. Modified bird base.

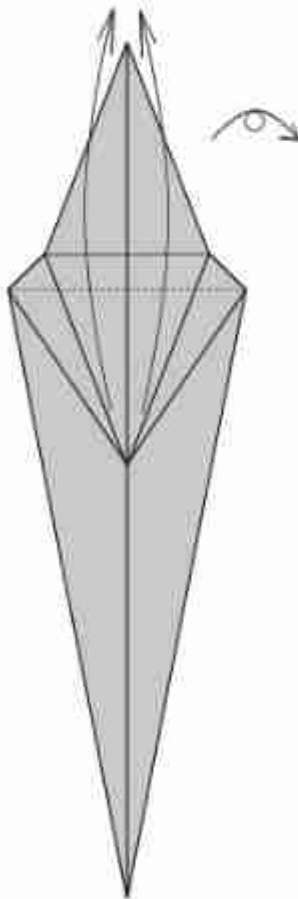

4. Fold both flaps up.
Turnover.

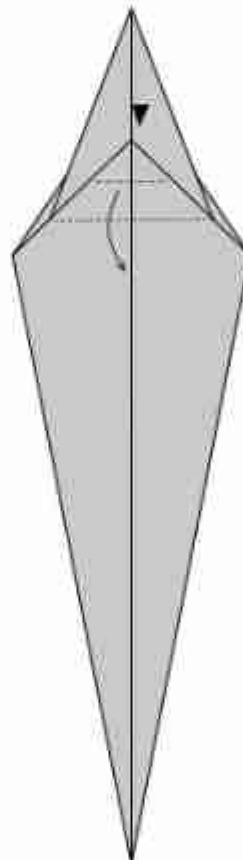

5. Spread squash.

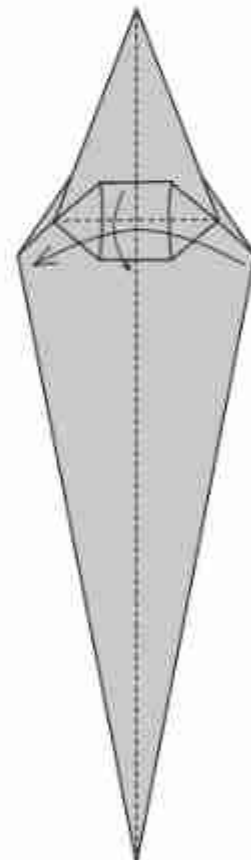

6. Fold spread squash down.
Fold model in half.

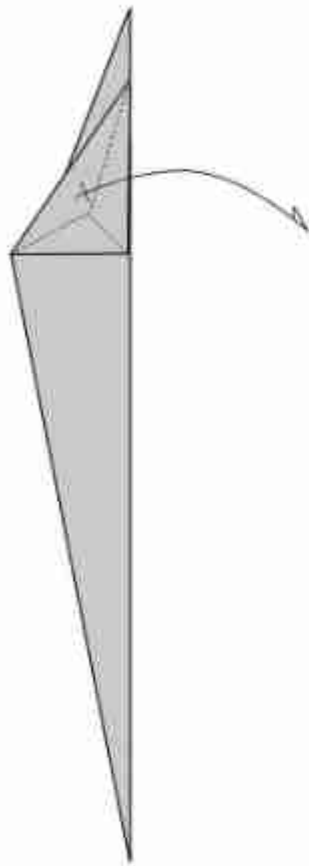

7. Rabbit ear.
Repeat behind.

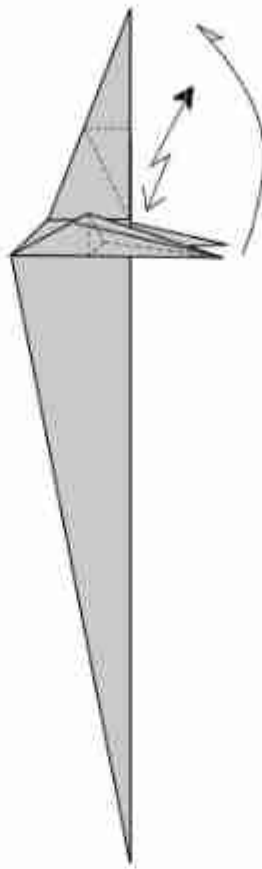

8. Precrease for head.
Rabbit ear legs and swivel up.

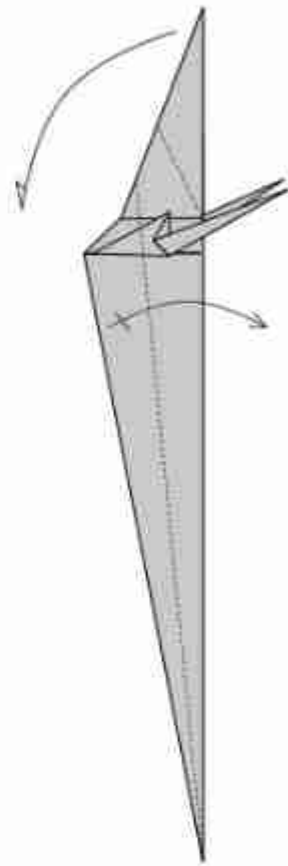

9. Reverse fold head along precrease.
Fold angle bisector for the tail.

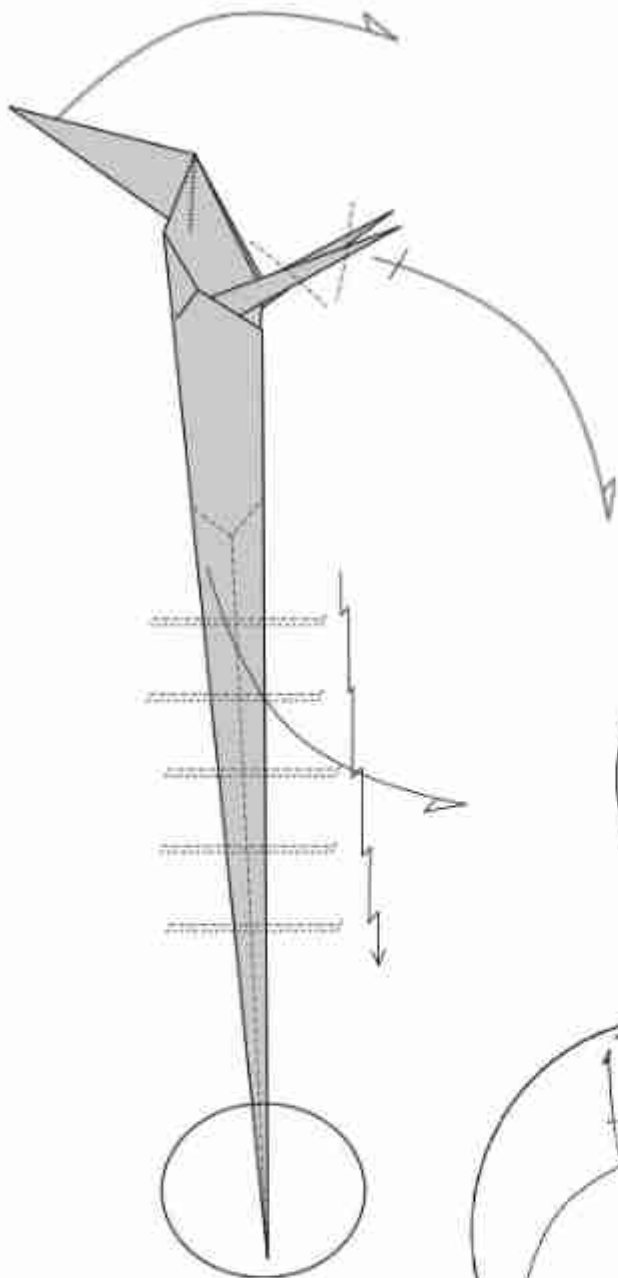

9. Reverse fold head.
 Reverse fold legs.
 Double rabbit ear tail and unfold.
 Accordion pleat the tail.
 Shape the tail using the accordion pleats.

Steps 10-12 are for the tail tip only.

The following steps are to open up the tail. It is a series of squash/petal fold. Almost, like an Elias stretch, but on an oblique angle.

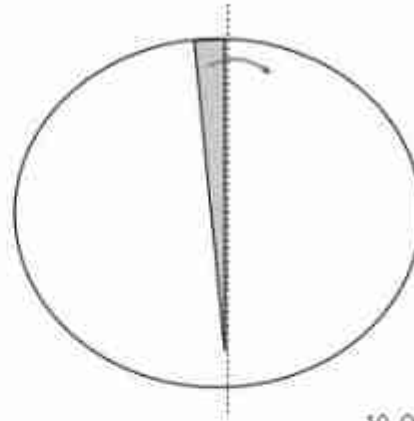

10. Open up the tip.

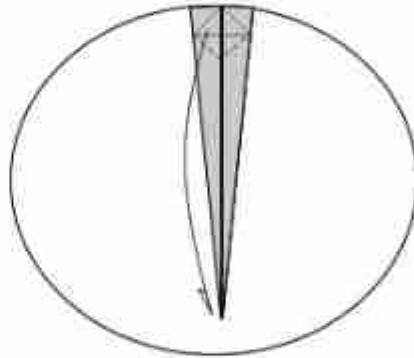

11. First petal/squash combination.

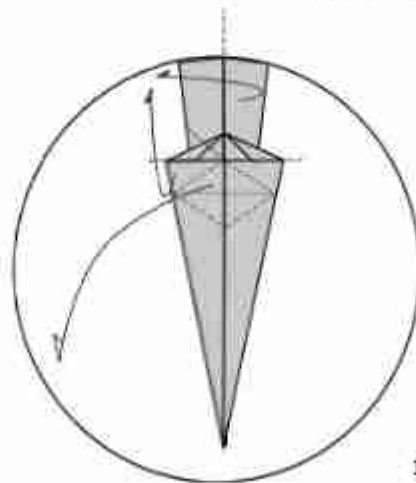

12. Second squash/petal fold combination.

Fold the trapezoid formed behind, up.

Mountain fold the tail in half while folding up the tail tip.



13. Outside reverse fold.

14. Crimp fold head.
Fold tip underneath.
Squash fold the tip of the leg to
form hooves. Repeat behind.

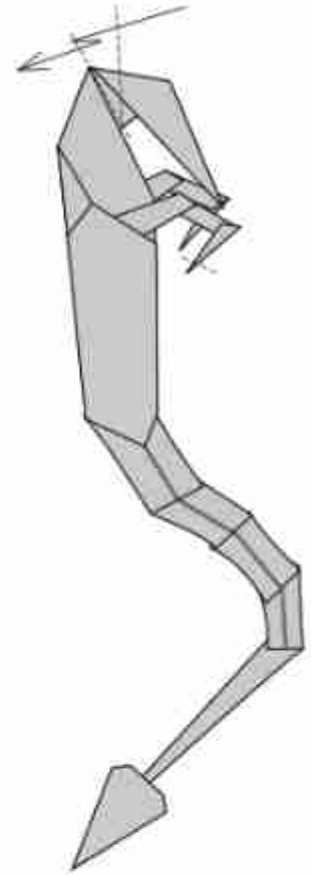

Close ups of both sides of the tail.

15. Round the body.
Fold down the mane



Falling Star Tato

Philip Chapman-Bell
Allan Kikawa (dgrms.)
©2021 - USA

High Intermediate

1. Valley fold the pentagon in half. Unfold. Rotate and repeat for all points.

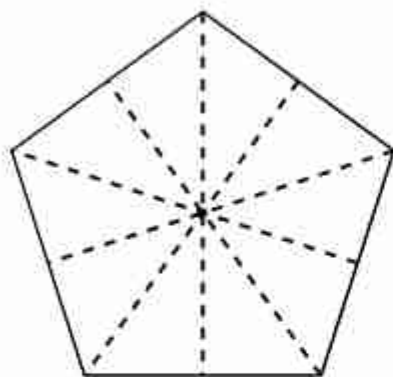

2. Valley fold a point to the center of the pentagon. Don't crease all the way. Unfold. Rotate and repeat for all points.

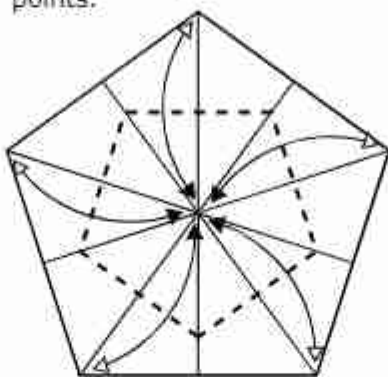

3. Form a star by folding and unfolding valley folds. The folds connect each point of the crease pentagon with its opposite 2 points.

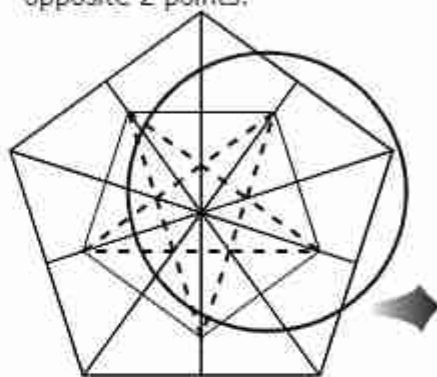

4. Valley fold and unfold a star inside the pentagon of the star formed in the previous step.

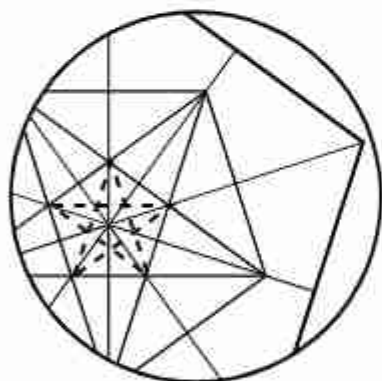

5. Valley fold and unfold a pentagon where the midpoint of each side meets a point of the star folded in the previous step.

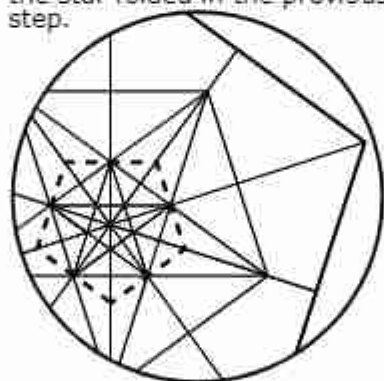

6. Mountain fold and unfold from the points of the pentagon in the previous step to the indents of the star folded in step 4.

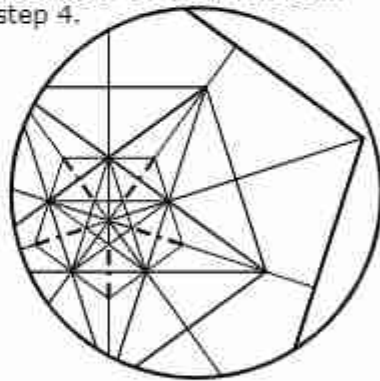

7. Valley fold along 2 adjacent sides of the pentagon formed by the large star in step 3. This forms a vertical fin.

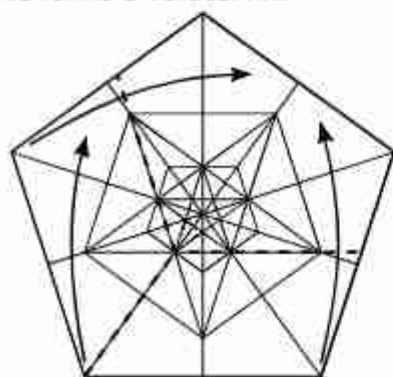

8. Fold the vertical fin down to the left.

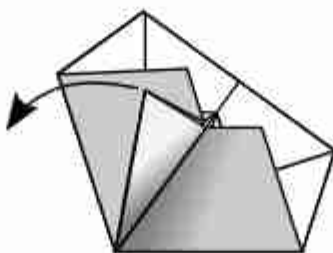

9. Unfold the previous 2 steps. Rotate the paper. Repeat the previous 2 steps for all sides. Unfold.

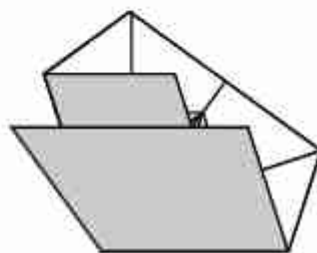

10. This shows creases after step 9. The bolded pentagon is used in the next step.

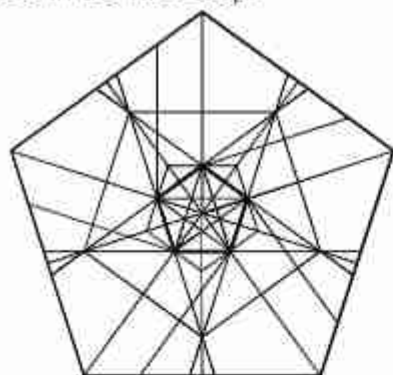

11. On existing creases, refold all 5 fins from step 7 at the same time. Rotate all 5 fins to the left.

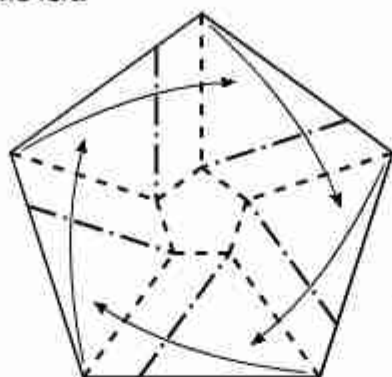

12. Valley fold the top layer of a point in half.

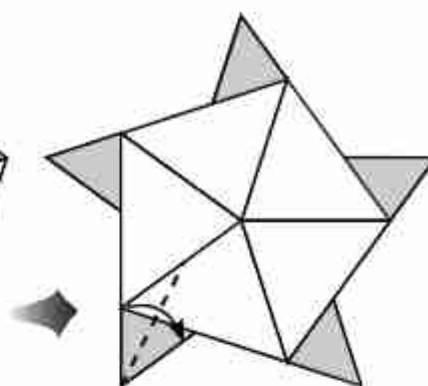

12. Valley fold from the top point of the previous fold to the adjacent star point. Pull paper from out from under the previous fold.

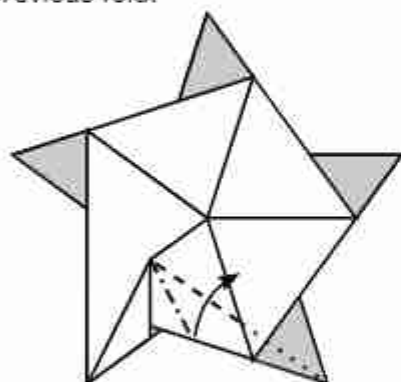

13. Rotate and repeat the previous 2 steps for all points.

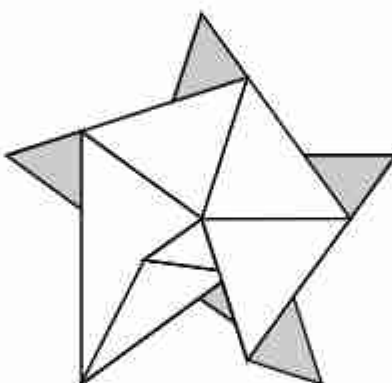

14. Turn the paper over.

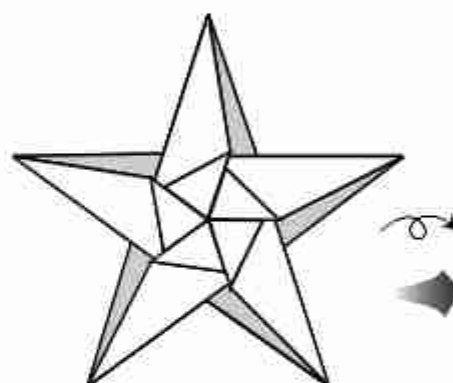

15. Push in on all sides of the small pentagon to puff up the star. You may need to temporarily open the back side of the model and push up from the back.

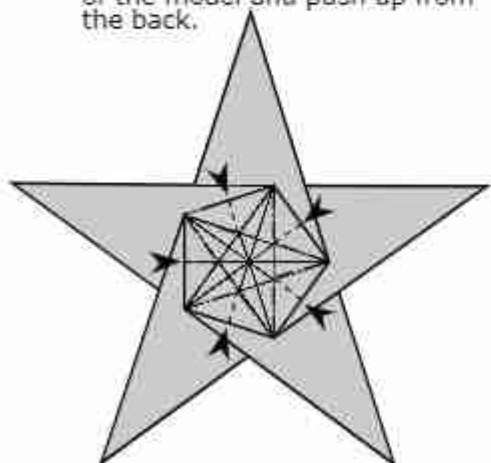

16. Locate the edge of the large star where it meets the point of the puffy star. Curve the edge of the large star upward.

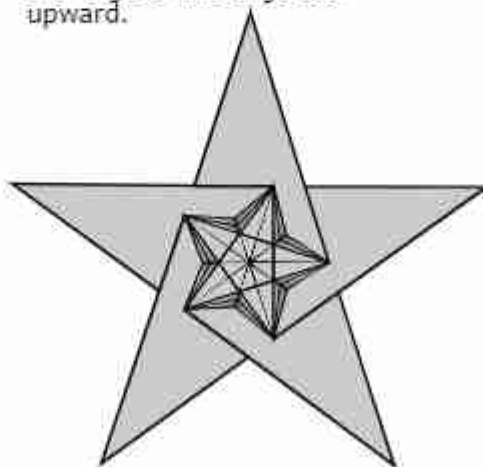

Hopping Grasshopper

Sy Chen

©2022 - USA

Simple

The classic simple grasshopper is easy and fun to play with. After looking at the edge of the model, I got an idea to make the distinguished legs using color change along 2 raw edges.

A 10 cm square makes a 7 cm long model.

1. Start from a duo-color square with the leg color side facing up;

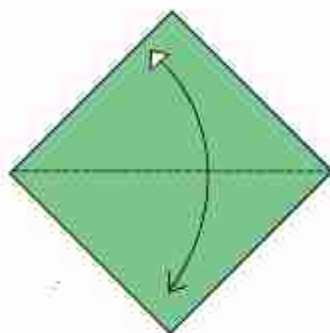

2. Fold the right corner to slightly to the right of the left corner. The gap will determine the leg width of the model.

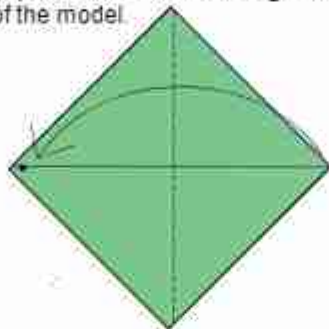

3.

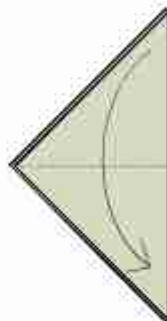

4.

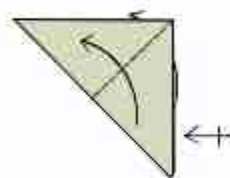

5. Repeat behind.

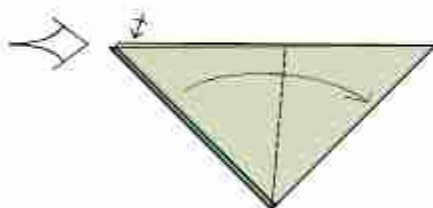

6. Judgement valley fold to reveal the hind leg and repeat behind.

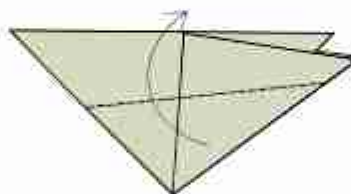

7. Completed.

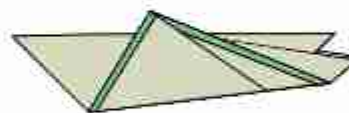

Option - Making Antennae

8. Outside reverse.



9. Outside reverse to reveal antennae.



10. Completed.



Hit and hop!

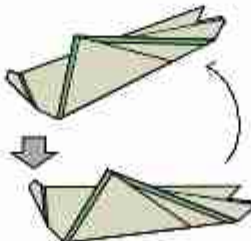
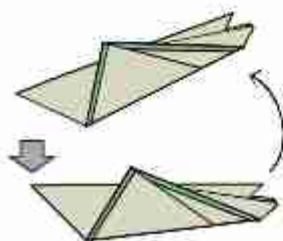

Pureland Cicada

Sy Chen

©2021 - USA

Low Intermediate

15 cm square makes a 7.5 cm long cicada.
Inspired by the coming brood X cicada swarm.

1. Start from a duo-color square with the eye color side facing up.

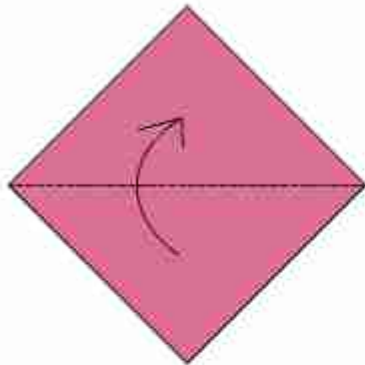

2.

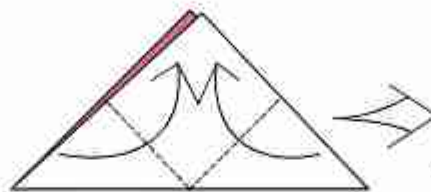

3. Fold 2 corners down and spread them apart as shown in the next step.

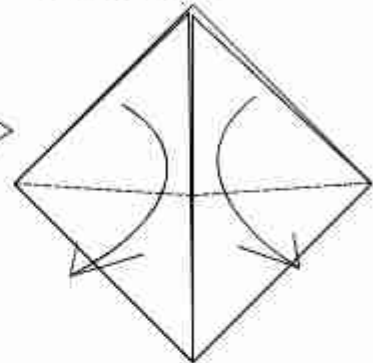

4. Get the midpoint pinch mark on the upper right edge; Mountain fold 2 corners near the center. The corner size is roughly 1/4 of the top triangular flap.

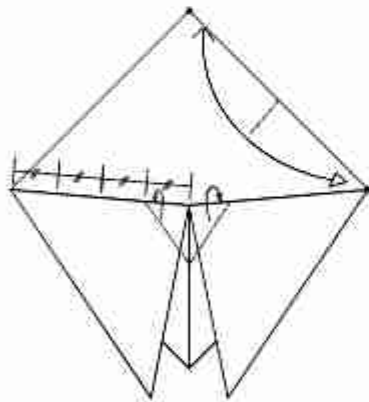

5. Pleat both layers together to align the dot to the bold line.

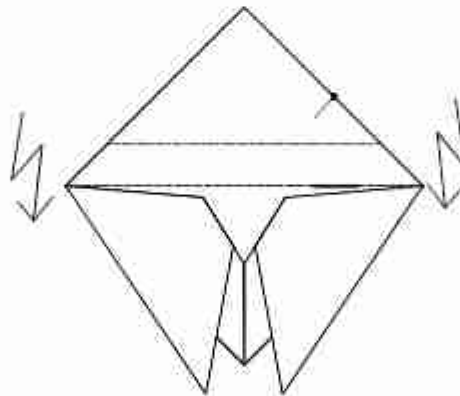

6. Fold the top layer down.

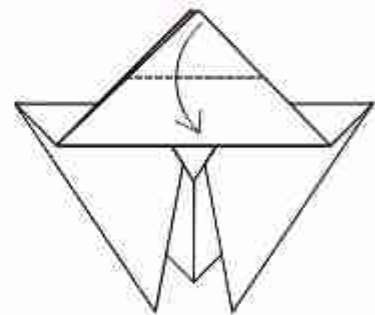

7. Judgement fold the top triangle. The location will determine the size of the eyes.

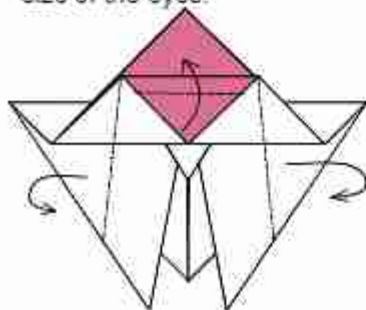

8. Valley fold to form eyes.



9.

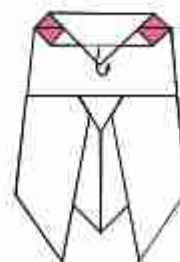

10. Completed.

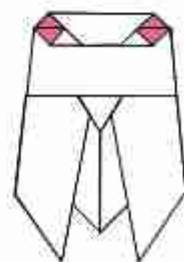

Tetromino Snake

Sy Chen

©2022 - USA

Intermediate

Designed in 1/2022 and diagrammed from 1/9/2022 to 1/11/2022.

After working on my version of the flexicubes, I was inspired by the various combinations of the linked cubes. It was an intriguing and challenging process to develop a design of 4 linked cubes that could make all possible Tetris blocks without breaking any of the links. The completed model is a fun puzzle to play with, even for non-folders.

1. Start from a square with the inner color side up if it is a duo-color square. Make creases.

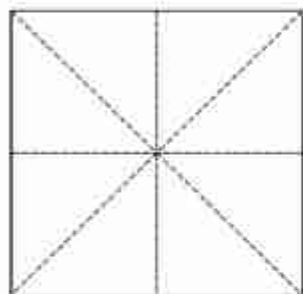

2. Divide the square with more creases.

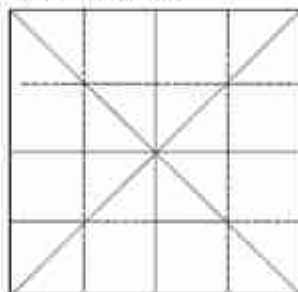

3. Make more diagonal creases.

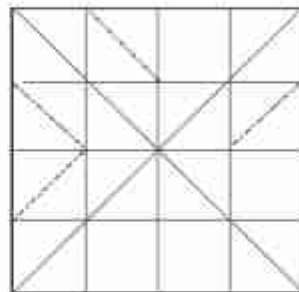

4. Bring the lower right corner up to form a 3D shape.

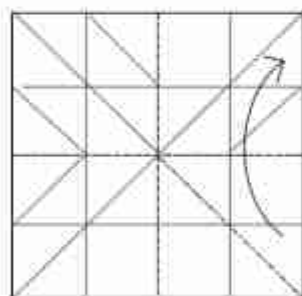

5. 3D view. Pleat the triangle flap and unfold.

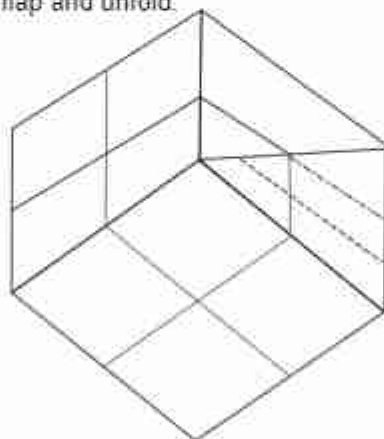

6. Inside reverse.

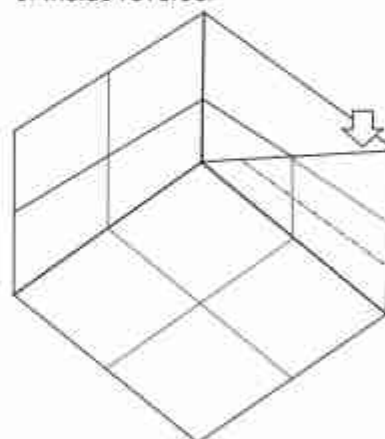

7.

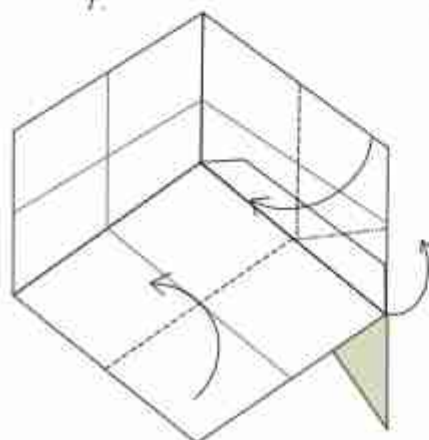

8. Bring the lower corner into the right pocket.

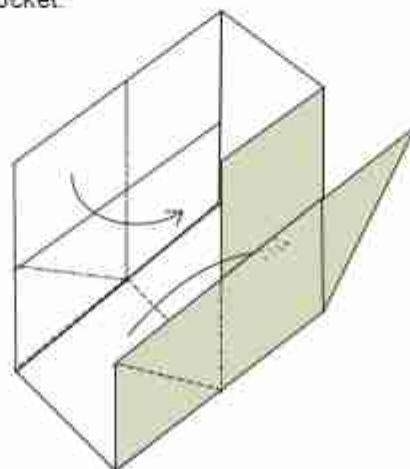

9. Fold the indicated flap beneath.

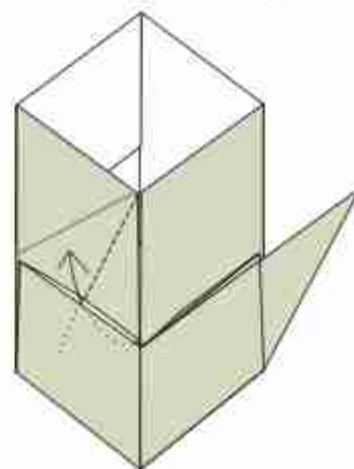

10. Close the top flaps to form a cube with 3 stick-out triangular flaps.

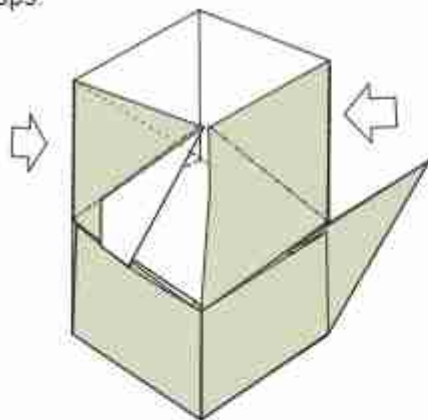

11. Fold the middle flap into the pocket. Bring the left flap down to reveal the top pocket behind.

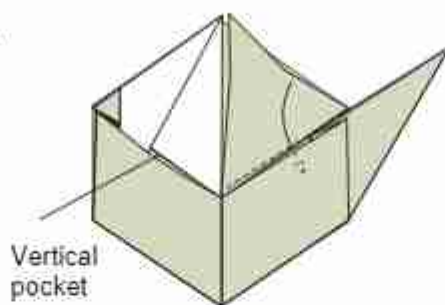

12. Tuck the left flap into either the top horizontal pocket (hold the shape better) or the vertical pocket (make the edge look cleaner).

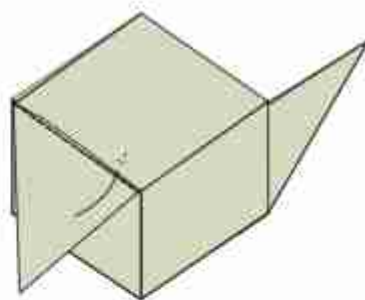

13. The completed unit, resembling a tadpole, with 1 tab and 2 vertical pockets (N and F). The tab is for connecting to the other unit. It can be swung both ways as a working hinge.

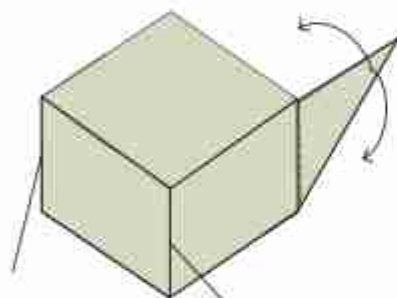

Pocket F-
Further away from
the tab

Pocket N-
Next to the tab.

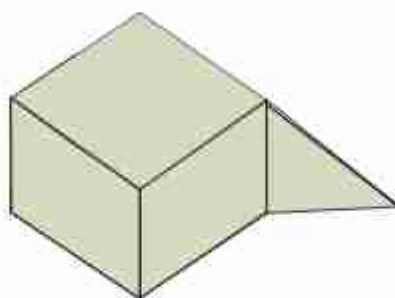

14. Make another 3 tadpole units.

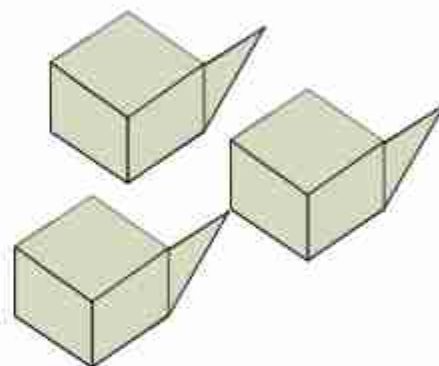

Pocket F(urther) Lock

a. Slide the tab into pocket F of a partially unfolded unit (step 9).

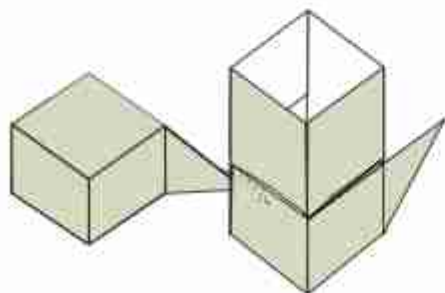

b. Make sure to fold both the inserted tab and pocket together and continue steps 10 to 12 to connect and secure the two units.

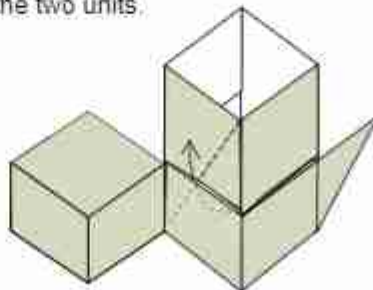

Pocket N(ext) Lock

a. Insert the tab into Pocket N of an unfolded unit (Step 9.)

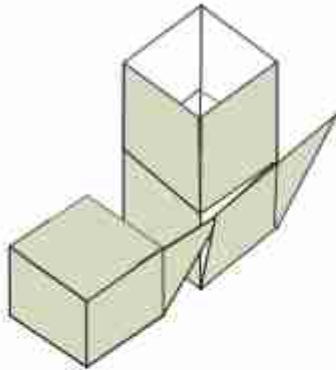

b. Make sure to fold both the inserted tab and pocket together behind the surface layer to secure the connection.

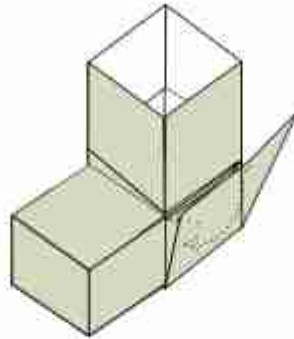

c. Continue steps 10 to 12. You can skip step 9 for Pocket N locking.

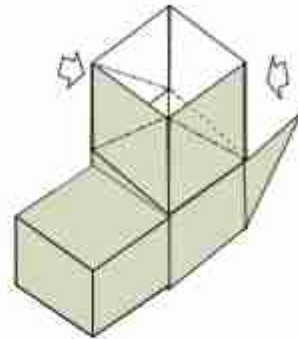

[Assembly] Connect the 4 units using 2 N locks and 1 F locks as illustrated starting from the left.

(1)

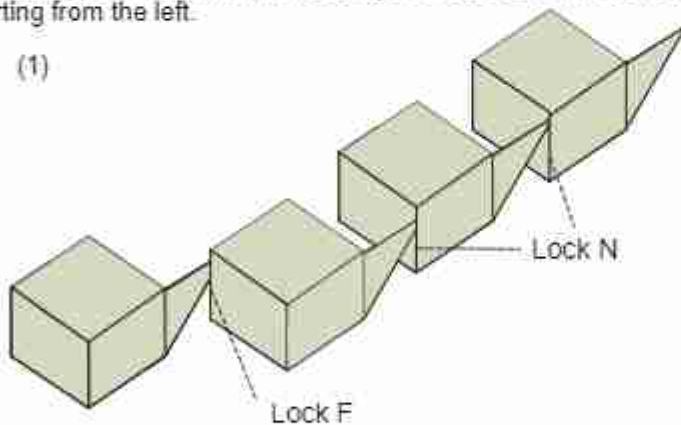

(2) The completed snake! Are you ready for the challenge?

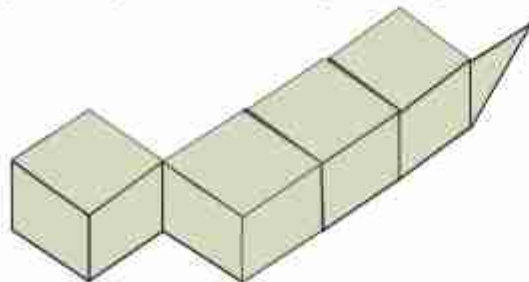

Challenge: Bend the snake to make the 5 basic tetromino shapes without breaking any links.

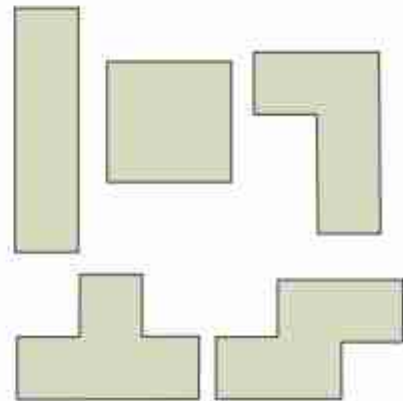

Tadpole Unit Alternatives

We only need one Pocket F unit, two Pocket N units, and one unit (either Pocket N or Pocket F) to assemble this design. The following images are the crease patterns of my alternative units. You can also use another modular model, such as Sonobe's unit to make the connected cubes.

Pocket N unit alternative

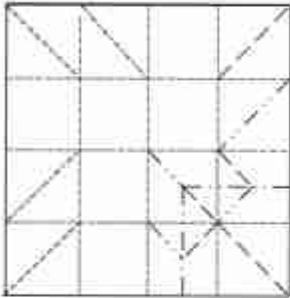

Pocket F unit alternative

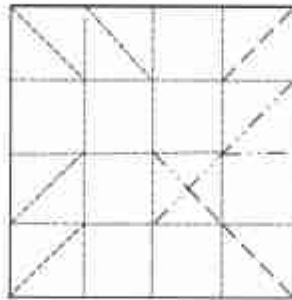

Diagrammed tadpole unit containing both Pockets N & F

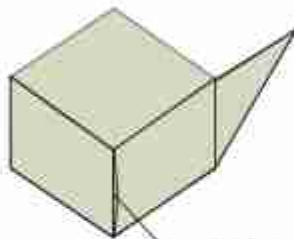
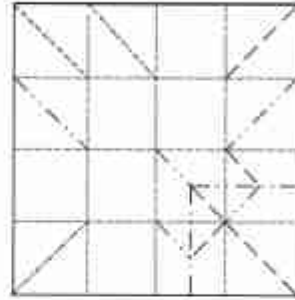

Pocket N

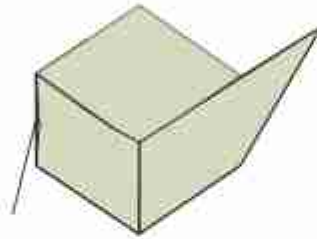

Pocket F

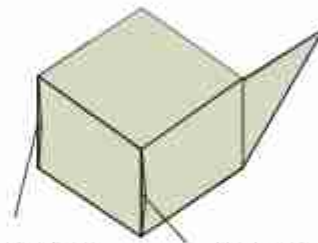

Pocket F

Pocket N

Tiger

Intermediate

Masayuki Ehara

©2021 - Japan

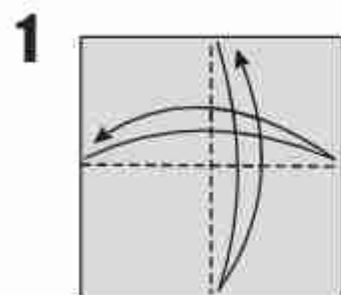

折り筋をつける

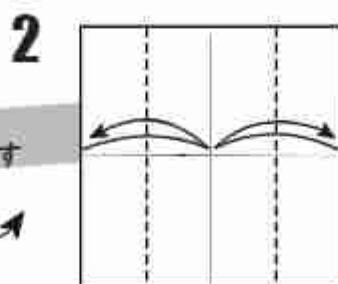

折り筋をつける

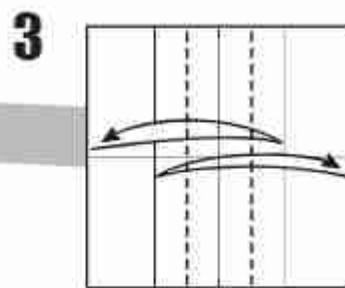

折り筋をつける

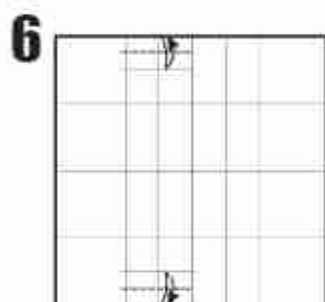

折り筋をつける

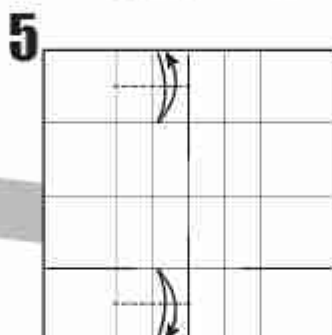

折る前に！
図14～17を見て
目安が要らないと思った輩は
図8へ飛んでくれ

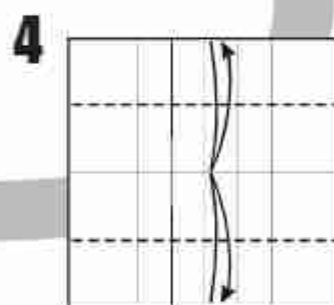

折り筋をつける

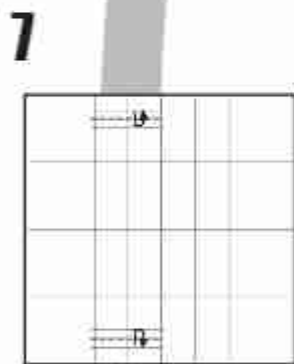

折り筋をつける

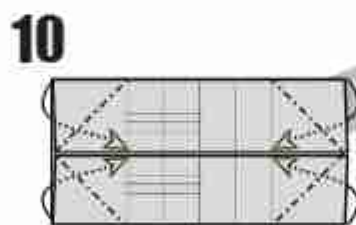

中割り折り
(4か所)

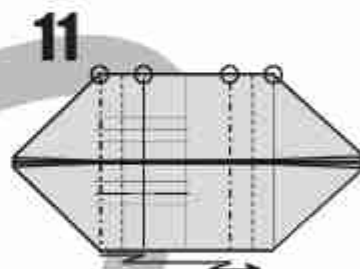

○を合わせるように
それぞれ段折り

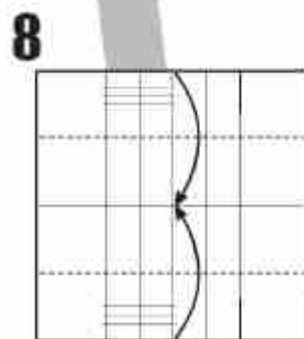

手前に折る

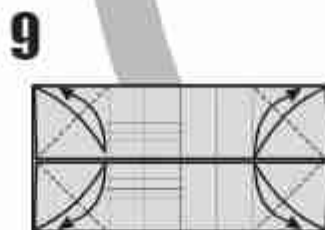

折り筋をつける

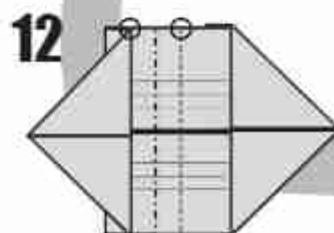

○を合わせるように
段折り

20

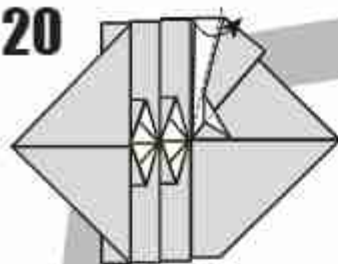

手前に折る

21

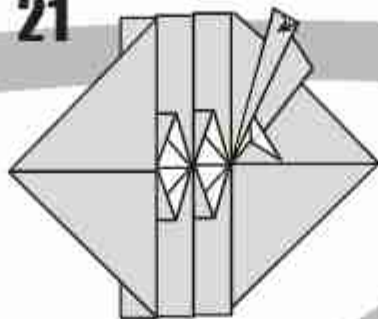

後ろに合わせて
折り返す

22

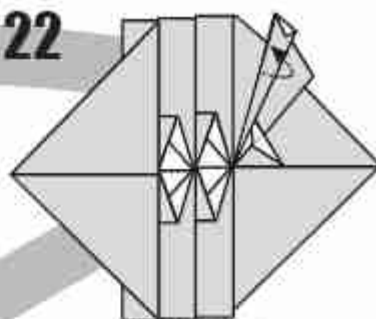

後ろの紙を
手前に出す

19

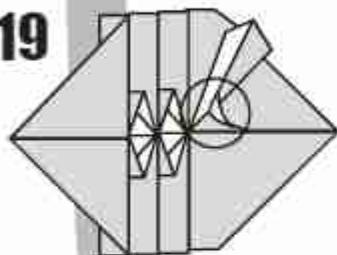

丸の部分が
引き寄せられるので
開いてつぶす

23

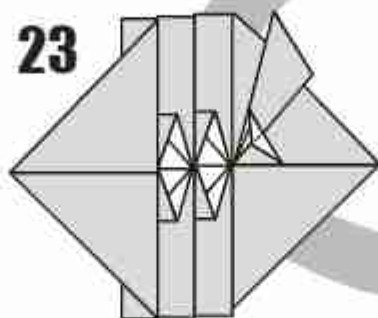

下側も図17~23

24

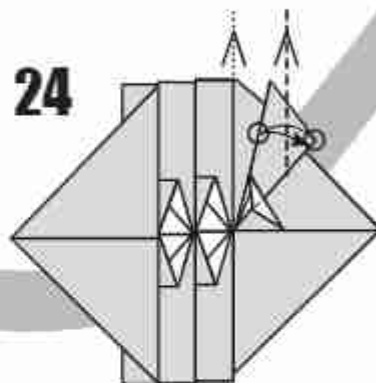

あくまで目安なので
気にしすぎないよう
折筋をつける

18

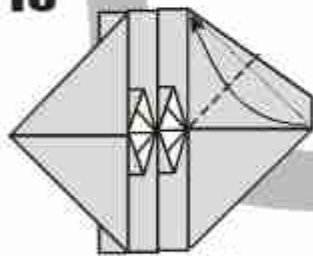

折り上げる

17

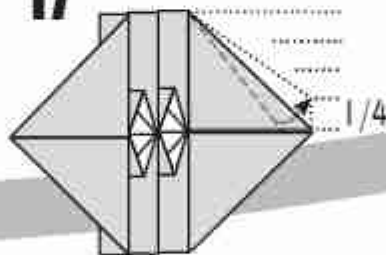

すぐ裏の紙を
ずらすように引き出す
(目安なのであまり
神経質にならぬよう)

16

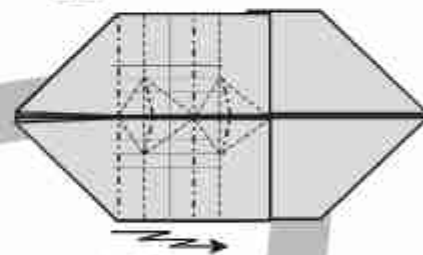

4か所
段折りしながら開く

13

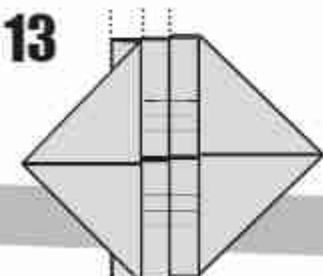

○部分を開く

14

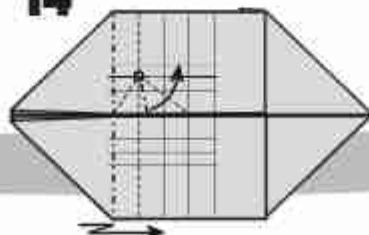

段折りしながら
開く

15

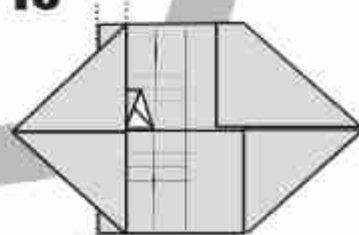

開く

25

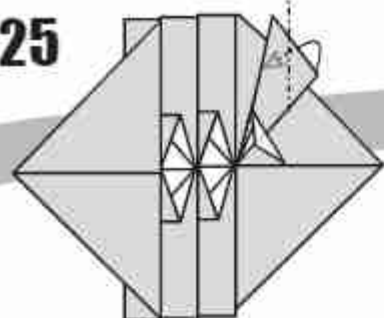

折り筋で
中割り折り

26

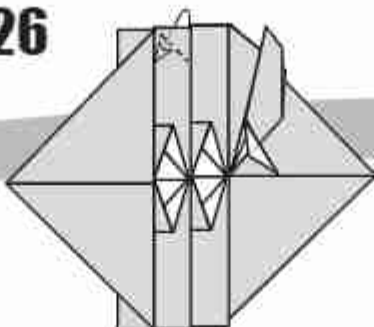

中割り折り

27

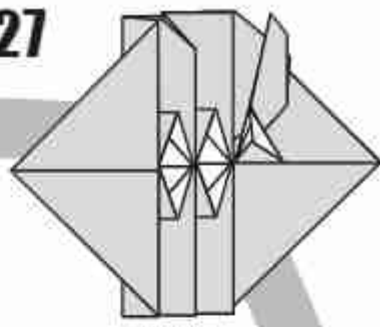

反対側も
図17~27

30

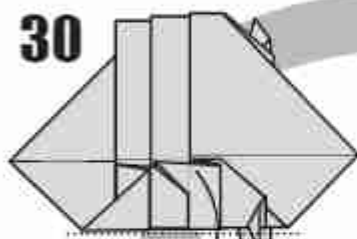

折った部分を
一度戻す

29

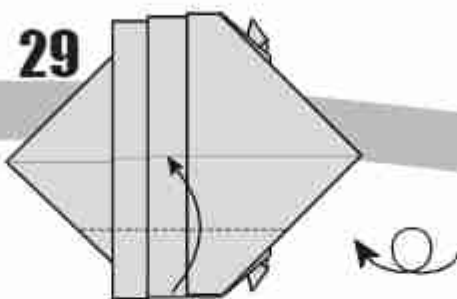

中心に合わせて折る
(図19と同じように
引き寄せられた部分を開く)

28

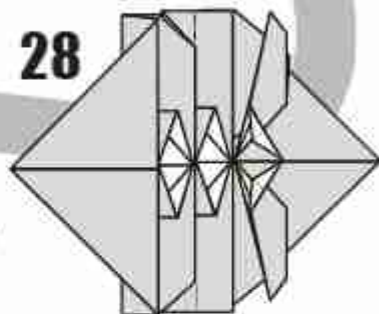

裏返す

31

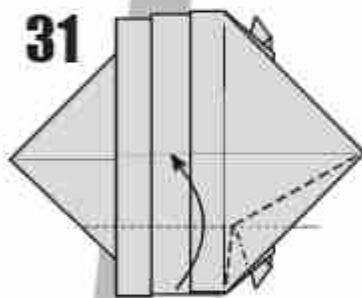

新たな折筋を加えて
折りなおす

35

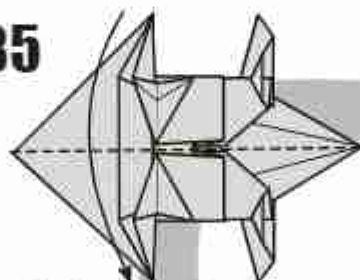

半分に折る

36



手前に折る

32

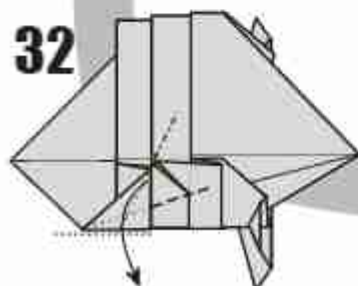

破けないよう開くだけ
(こだわらなければ多少破けても
問題ないさ~)

33

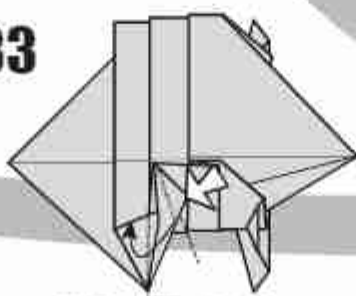

綺麗に開けるが
ぐしゃっとなっても
隠れるから問題なし!

34

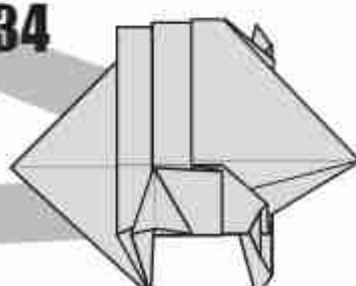

反対側も頑張って!

45

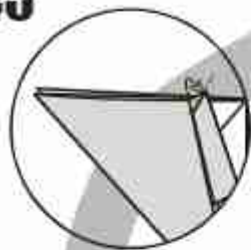

中割折り

46

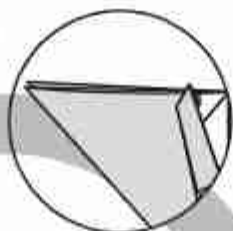

全体図に戻る

48

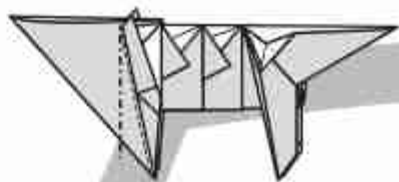

段折り
(裏も)

47

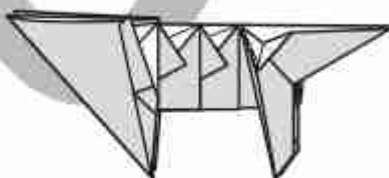

反対側も
図36~47

44

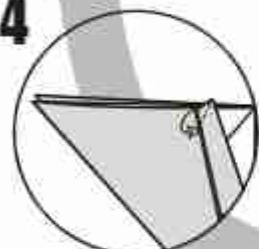

裏へ折る



拡大

43

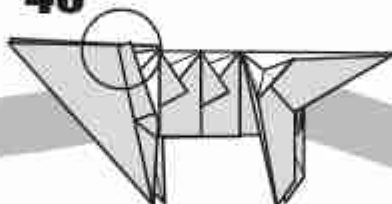

42

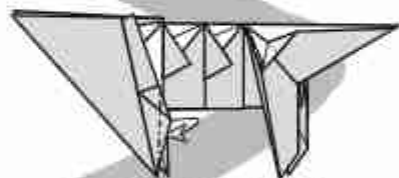

裏の紙に合わせ
中に折る

37

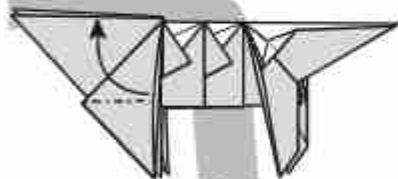

開く

41

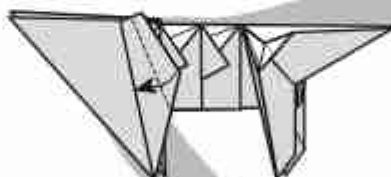

手前に折る

38

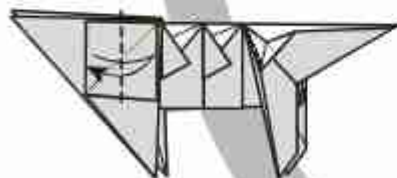

折り筋をつける

40

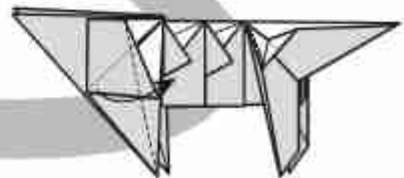

手前に折る

39

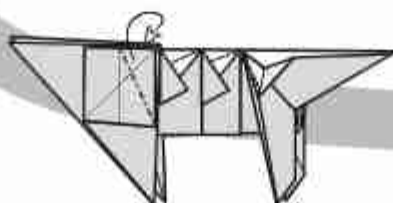

裏へ折る

49

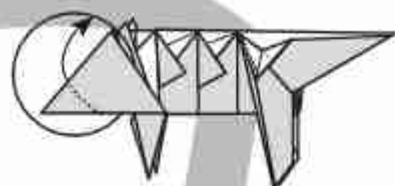

中途半端に開く

59

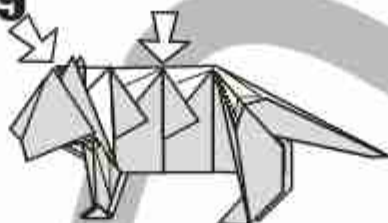

圧力を加え
立体的にするといいぞ

58

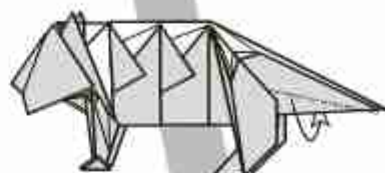

尾を細く折る

50

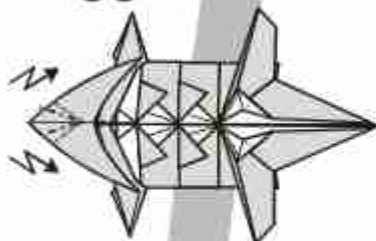

段折りで
鼻先を作る

おそらく完成

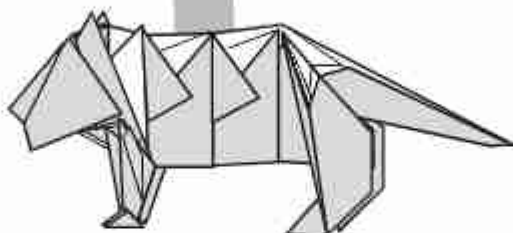

作図は多少美化してるかもしれない。
図に騙されないよう
現実的に折ってくれ!

57

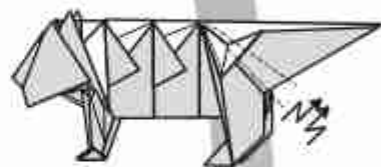

尻尾を段折り
この辺りはあなたの目が
目安です

51

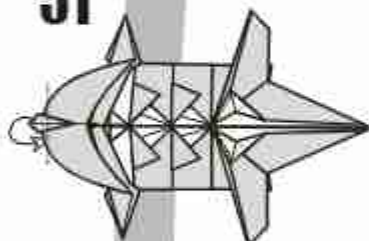

先端を裏へ

56

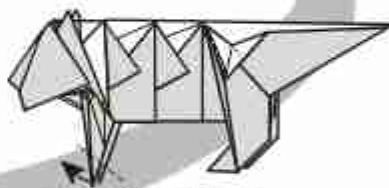

前足を折り返す
(中割でもお好きなように)

55

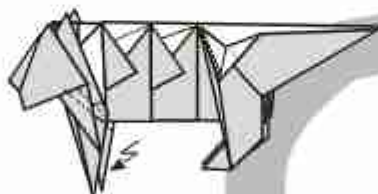

前足を段折り
(少しでも首がないことを
ごまかすため)

52

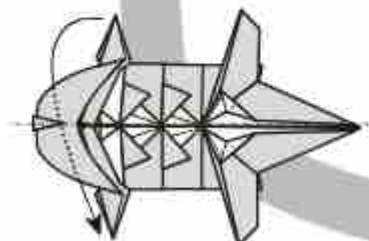

半開き終わり

53

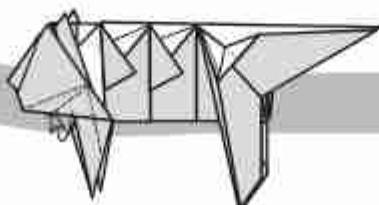

顔をスリムに
(ついでに足の紙が
引き寄せられる、
この辺りはアバウトに)

54

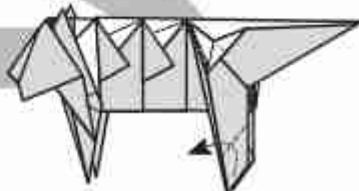

足を折り返す
(中割折りでも好きなほうで)

Penguin and Chick

Richard Ellison

©2021 - USA

Intermediate

Use a 6" or larger square of kami or other thin paper colored black on one side and white on the other.

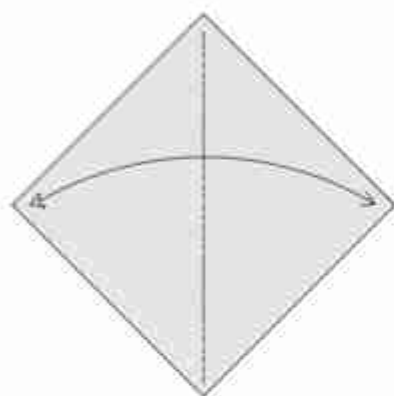

1. Begin with the colored side up. Fold and unfold the diagonal.

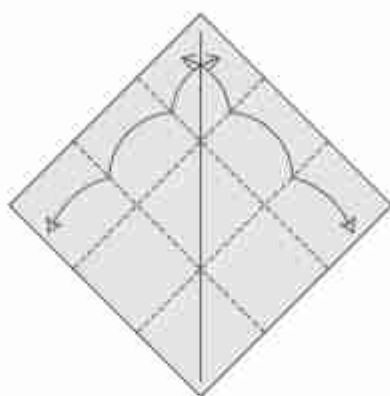

2. Fold and unfold the square into thirds both ways.

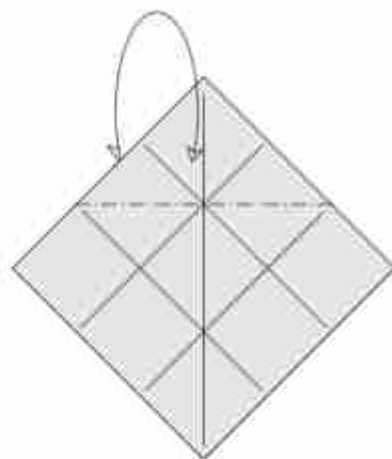

3. Mountain fold and unfold.

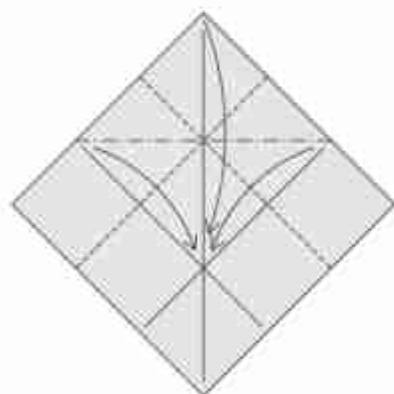

4. Collapse the top portion of the paper along existing creases, similar to a Preliminary Fold.

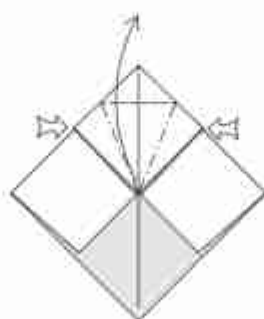

5. Petal fold.

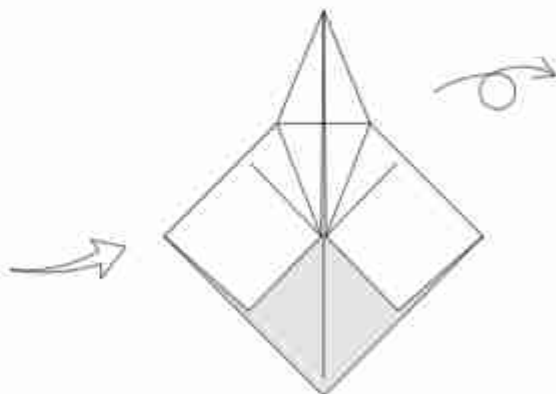

6. Turn the model over from left to right.

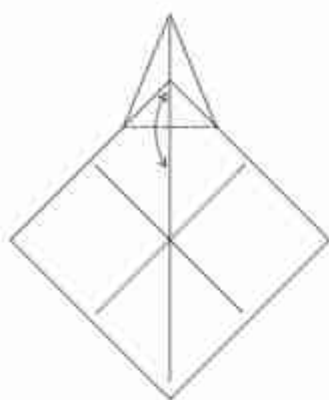

7. Valley fold the short flap down as far as it will go. Unfold.

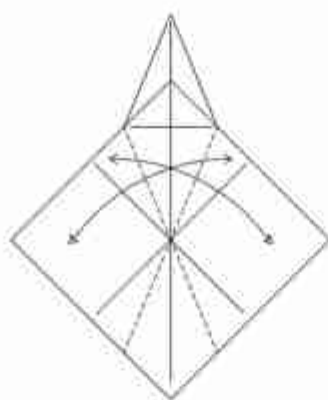

8. Fold and unfold through all layers. The creases align with folded edges behind.

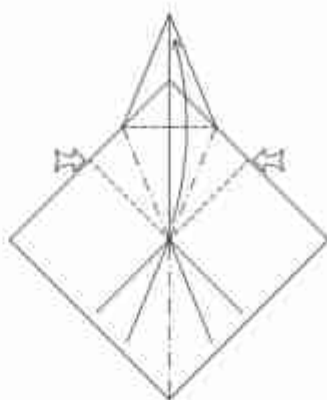

9. Petal fold the upper quadrant of the front layer, carrying the excess paper along with it. You are folding the other half of the bird base begun at step 5.



10. Step 9 in progress. The completed Bird Base is flat on the table and a lot of excess paper forms a flap standing straight up. Flatten it over to the right.

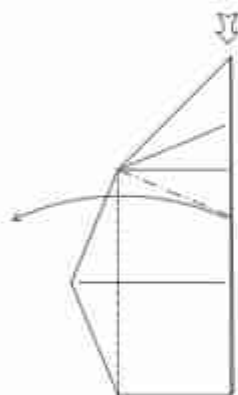

11. Squash fold.

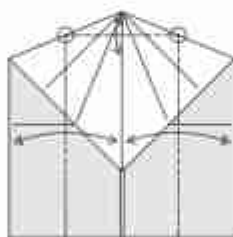

12. The model is now symmetrical. Fold and unfold.

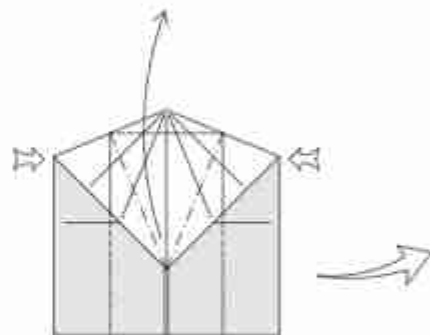

13. Petal fold.

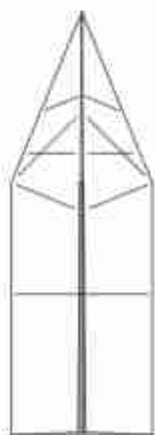

14. Turn the model over from left to right.



15. Valley fold a single flap straight down along its hinge.

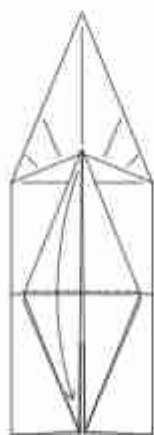

16. Open sink the short flap to one half its length.

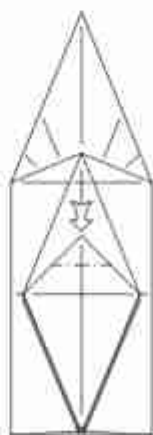

17. Bring one layer of paper to the front - a closed wrap. This step is optional, and has only a minor effect on the final appearance.

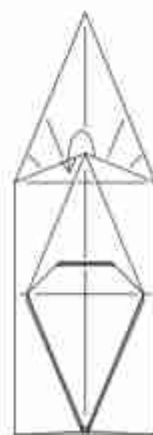

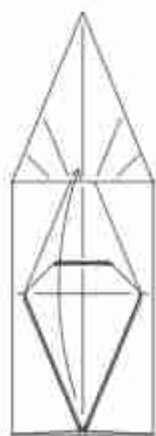

18. Swing a single flap back up.



19. Wrap one layer of paper back one layer, left and right sides. This will require allowing the model to partially unfold.

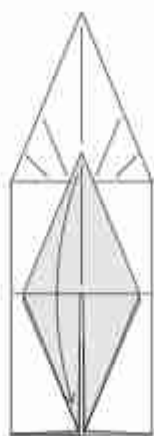

20. Swing a single flap back down. This time, it will carry the sunken point from step 16 with it.

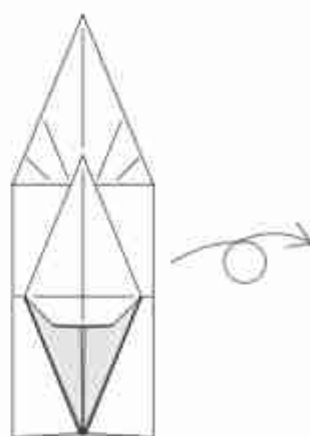

21. Turn the model over from left to right.

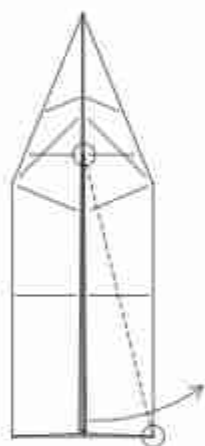

22. Valley fold a single layer.

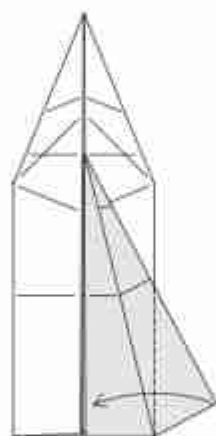

23. Valley fold to align with the folded edge behind.



24. Unfold to step 22.



25. Reverse the two creases created in steps 22 and 23, tucking a folded edge behind.



26. Valley fold.



27. Valley fold through all layers.

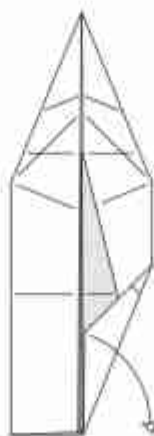

28. Unfold to step 26.



29. Valley fold, reversing an existing mountain crease.



30. Valley fold.

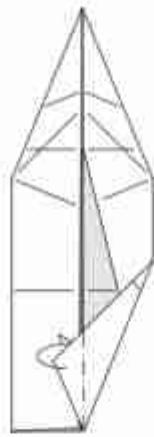

31. Tuck this point inside the flap behind it, using the existing mountain crease.

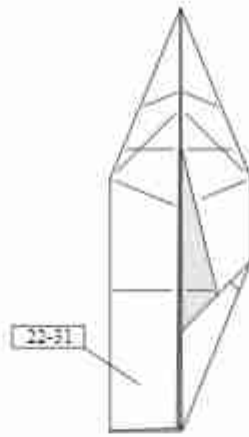

32. Repeat steps 22-31 on the left.



33. Valley fold one point straight up along its hinge, left and right sides.

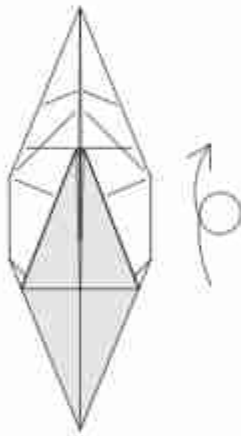

34. Turn the model over from top to bottom.



35. Valley fold, bringing the two circled points together. Make this a soft crease. Unfold.

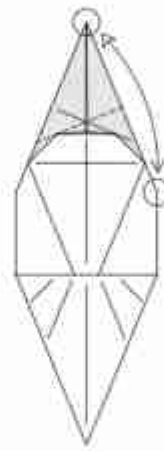

36. Repeat step 35 on the right, again, with a soft crease. Unfold.

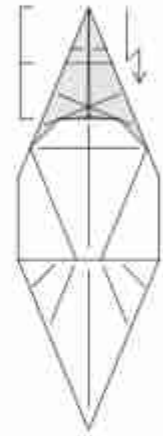

37. Pleat. The valley fold is about halfway to the sunken edge.

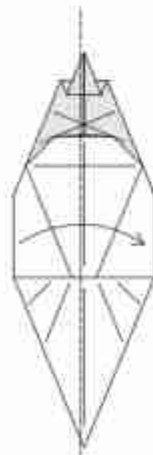

38. Valley fold the entire model in half.

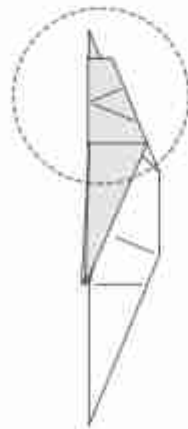

39. The following steps focus on the circled area.

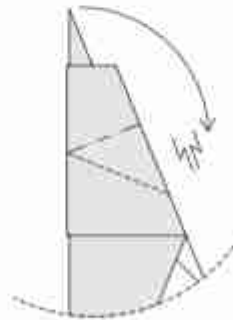

40. Crimp along existing creases. Do not firmly flatten; keep the creases soft.

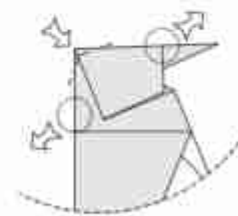

41. Hold the model at the circled points and gently pull apart while pressing inward at the location indicated. The back of the head will sink in and become more rounded.

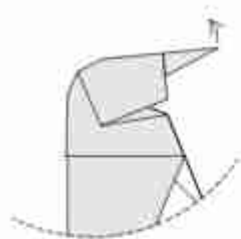

42. This is the result. Reposition the head to tilt slightly upwards and commit the crimp fold.

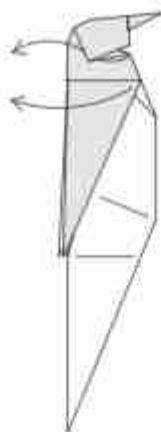

43. Swing one layer over to the left, allowing the front half of the crimp to unfold completely.

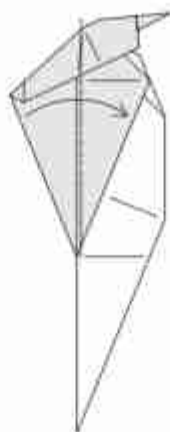

44. Flatten. Valley fold the layer back over to the right.

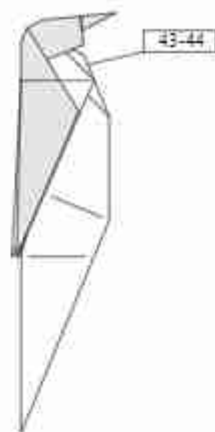

45. Complete. Repeat steps 43-44 behind.



46. Valley fold.



47. The wing is not shown for clarity. Crimp.

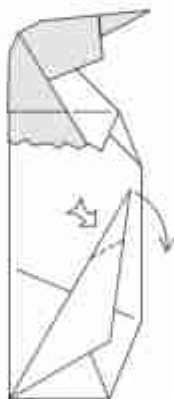

48. Outside reverse fold. One layer goes in front and two go behind.

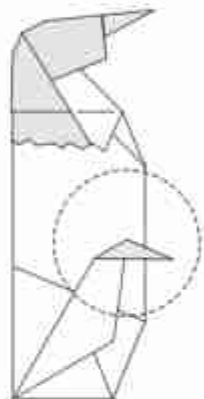

49. Steps 50-52 focus on the circled area.

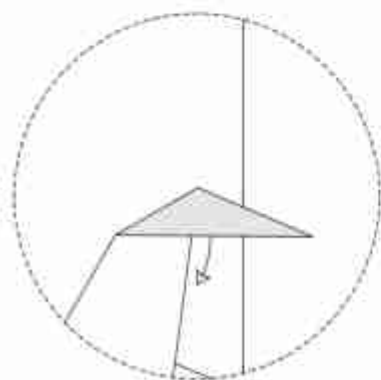

50. Pull out the trapped paper.

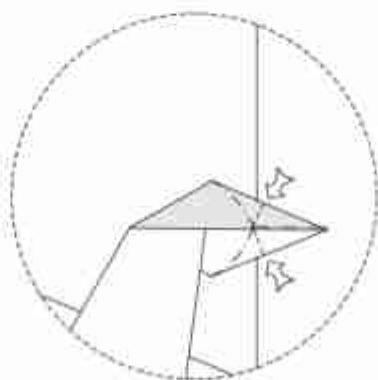

51. Pinch to form a beak.

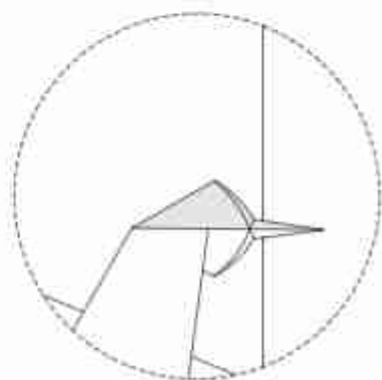

52. Enlarged sequence completed.

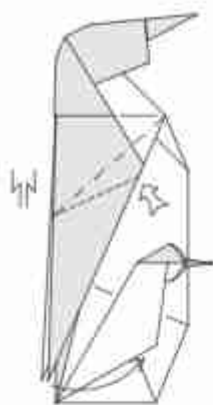

53. Crimp the wing.

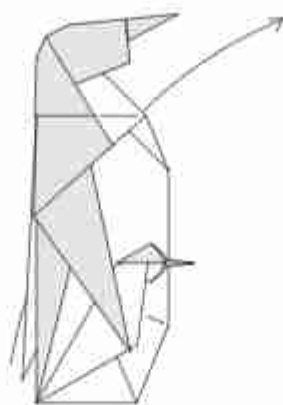

54. Reposition the wing behind to taste. The next step shows it pointing up at an iceberg.

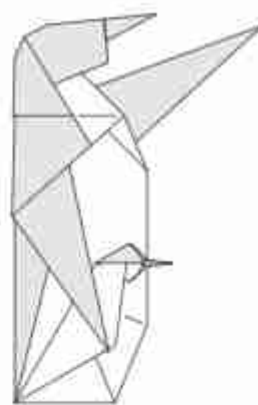

55. The completed Penguin and Chick.

The paper dedicated to the chick can alternatively become a pair of feet. Likewise, the wings can be posed in various ways. An alternate design is diagrammed below.

Alternate Design with Feet



46. Inside reverse fold.

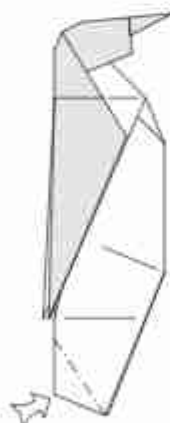

47. Open sink.

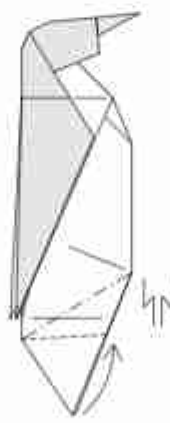

48. Crimp.

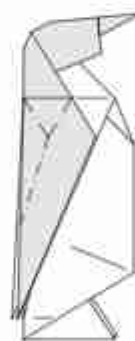

49. Form a soft rabbit ear. Repeat behind.



50. Complete.

Toy Unicorn

Oriol Esteve

©2021 - Spain

Intermediate

Recommended paper:
Kami 15 cm

Diseño: 2021
Papel recomendado:
Kami 15 cm

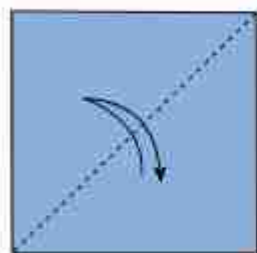
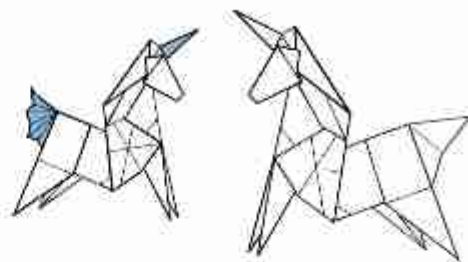

1.

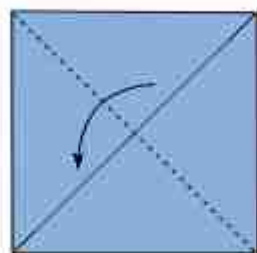

2.

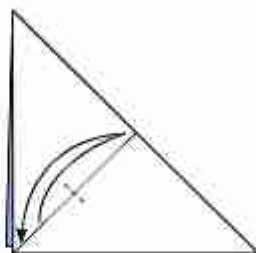

3.

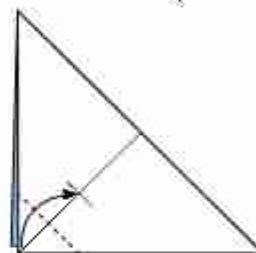

4.

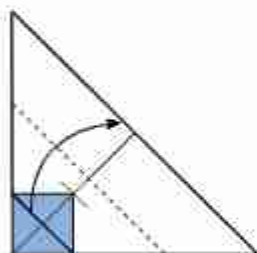

5.

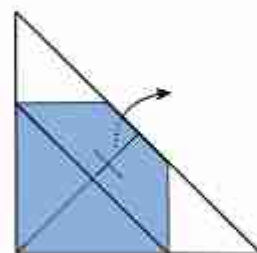

6. Release the tip.
Liberar la punta.

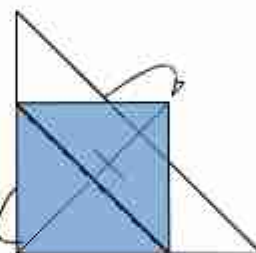

7.

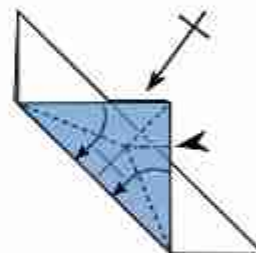

8.

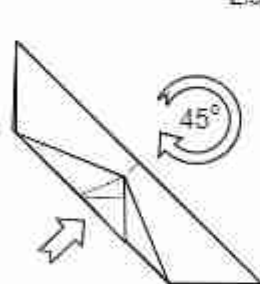

9. Open.
Abrir.

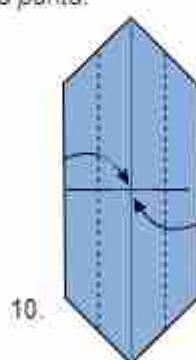

10.

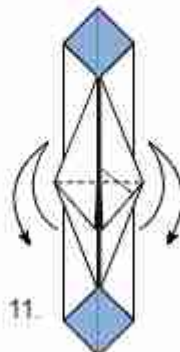

11.

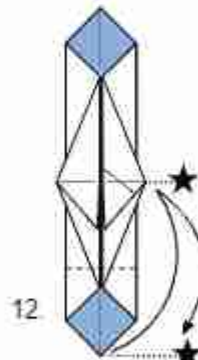

12.

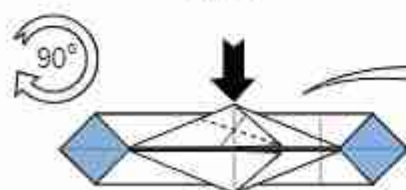

13. Fold the bisector and squash the layers.
Plegar la bisectriz y aplastar el grupo de capas.

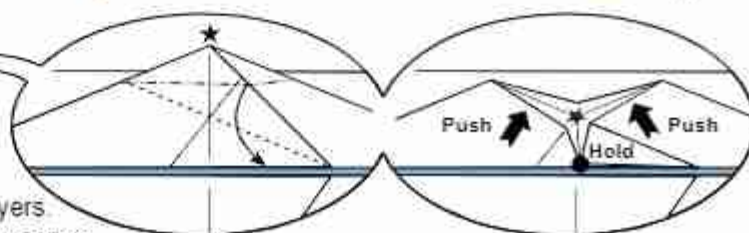

Note: this edge aligns
with the newly squashed area.
Nota: este borde coincide
con el borde del área aplastada

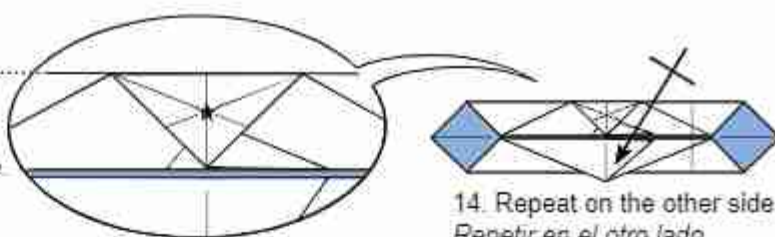

14. Repeat on the other side.
Repetir en el otro lado.

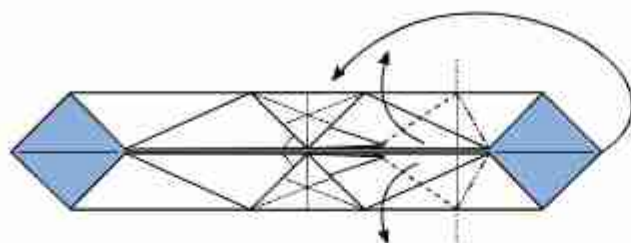

15. Spread flaps and mountain fold from the existing crease
to the corner. Valley folds come naturally after this operation.
*Extender las solapas desde la marca existente hacia
las esquinas. Los pliegues en valle salen naturalmente.*

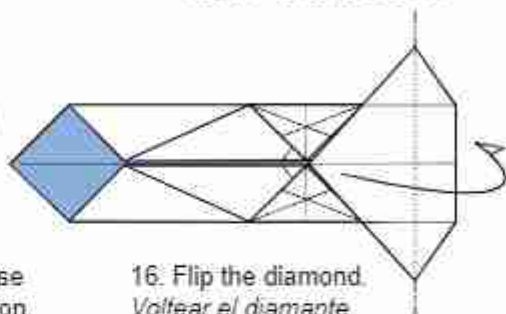

16. Flip the diamond.
Voltear el diamante.

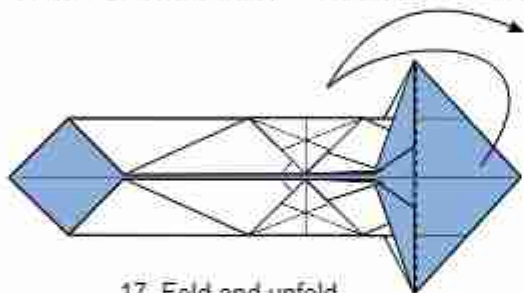

17. Fold and unfold.
Marcar.

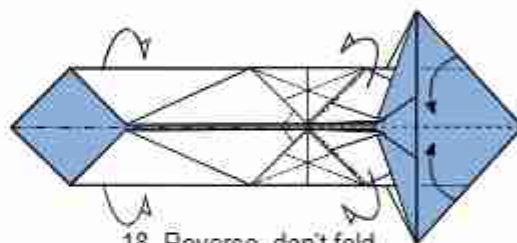

18. Reverse, don't fold
the central thin tips.
*Invertir, sin plegar
las puntas centrales.*

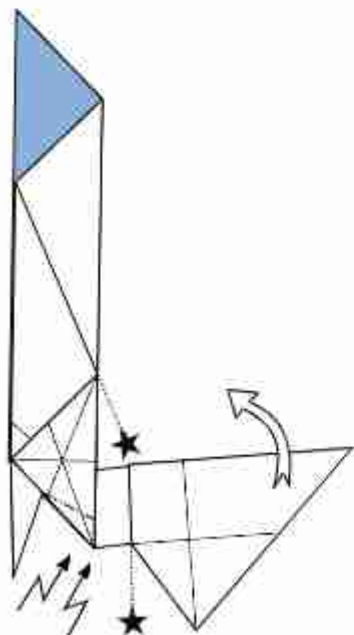

19. Keep reversing until edges with the star are parallel or aligned.
*Continuar el invertido hasta que los bordes con la estrella estén
en línea o en paralelo.*

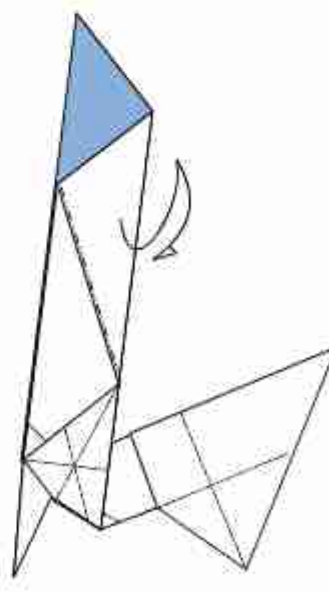
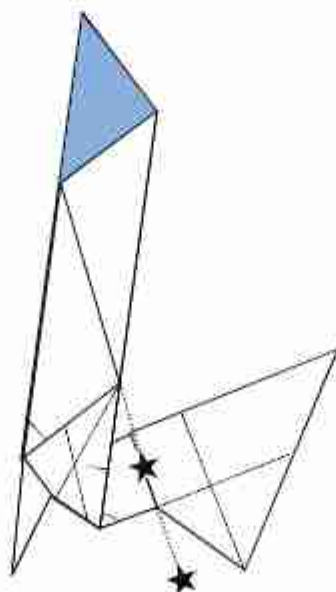

20. Fold back and unfold.
Llevar atrás y deshacer.

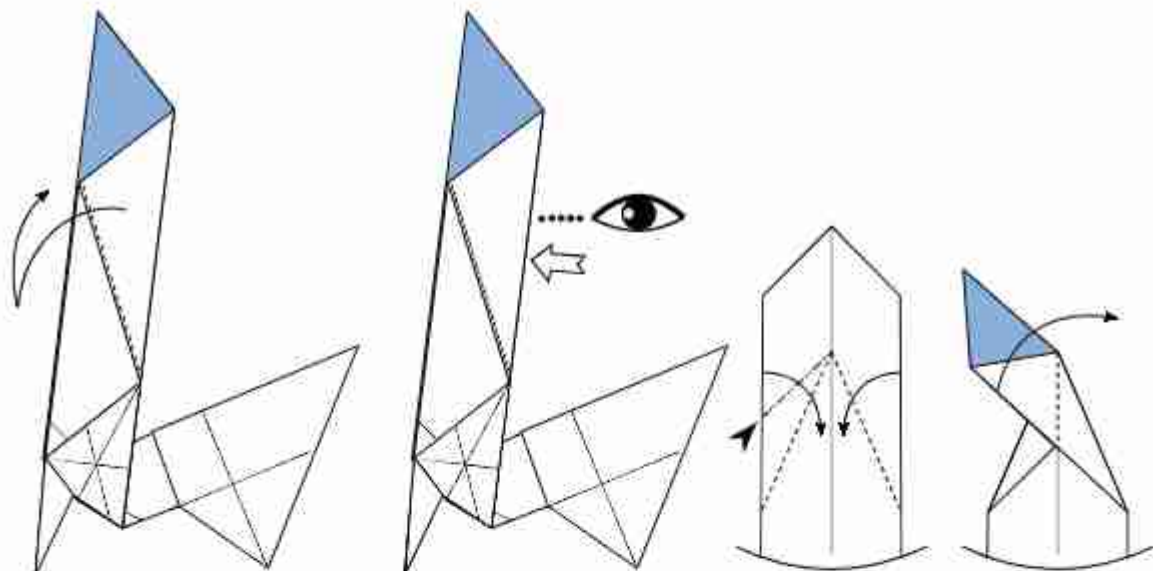

21. Mark same crease with a valley. 22. Open to work behind.
Marcar la misma sección en valle. Abrir para trabajar detrás.

23. Use the existing valleys to collapse. 24.
Usar las marcas en valle para colapsar.

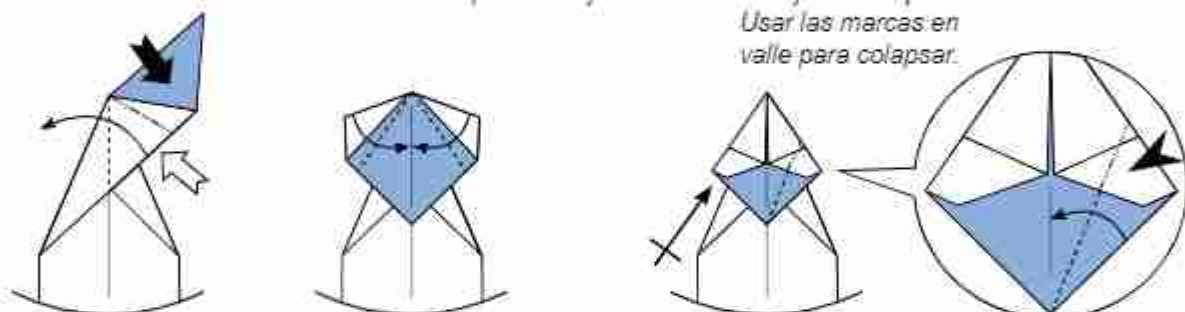

25. Open and squash.
Abrir y aplastar.

26.

27. Fold the bisector, reversing the flap on the corner.
Plegar por la bisectriz, con un invertido en la esquina.

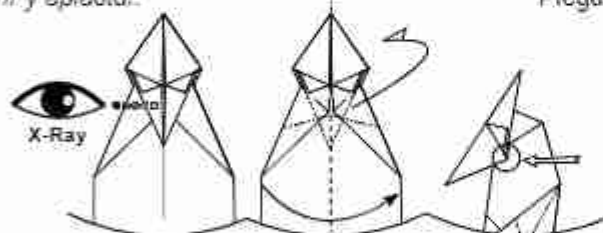

28. This reverse sets the length of the neck. Under the intersection of layers, fold to get a nice proportion (head's corner overlaps the neck).
Este invertido establece la longitud del cuello. Plegar por debajo de la intersección de capas para una buena proporción (la cabeza se solapa sobre el cuello).

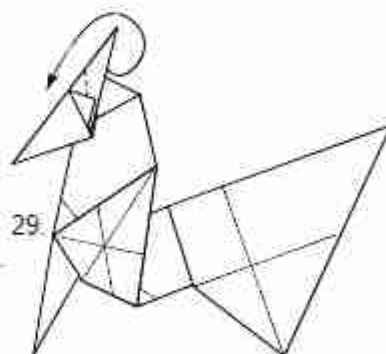

29.

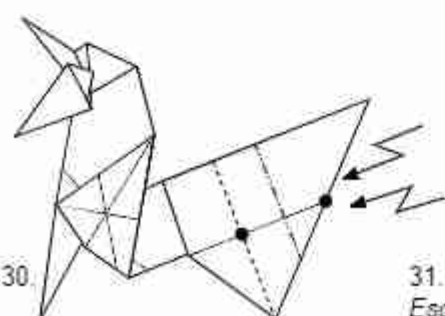

30.

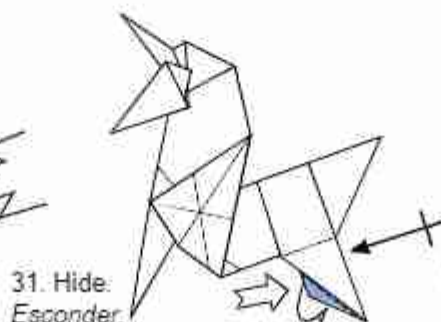

31. Hide.
Esconder.

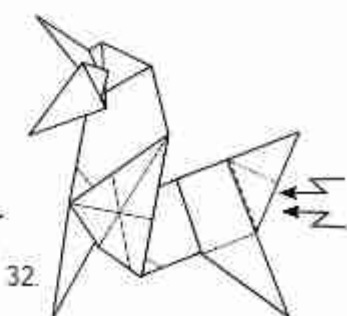

32.

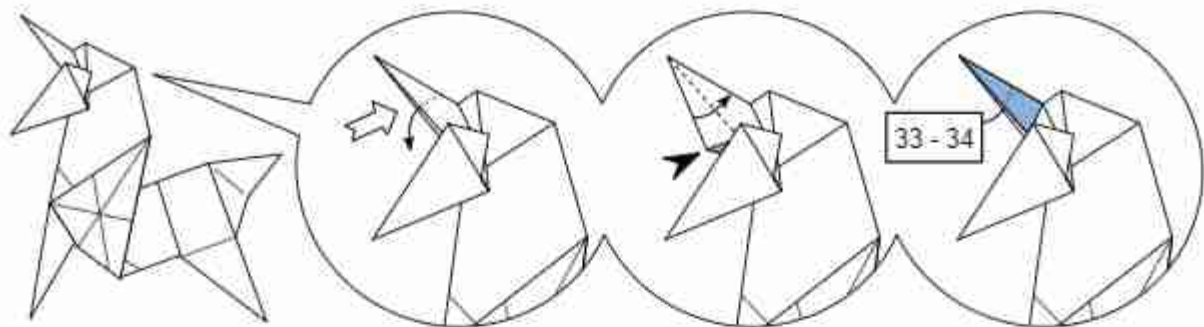

33. Released the inner flap.
Liberar la solapa interior.

34. Reverse.
Invertir.

35. Repeat on the other side.
Repetir en el otro lado.

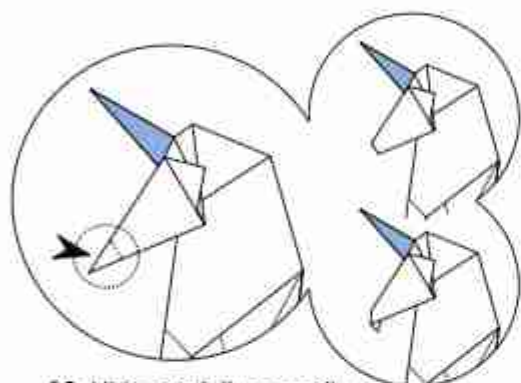

36. Hide, partially or totally.
Ocultar, parcial o totalmente.

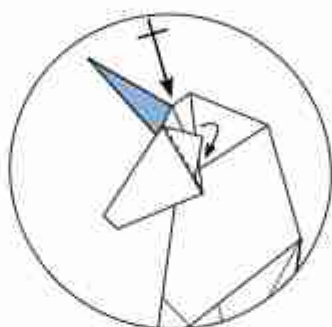

37. Separate the ear.
Separar la oreja.



38. Almost reach the body.
Llegar casi al lomo.

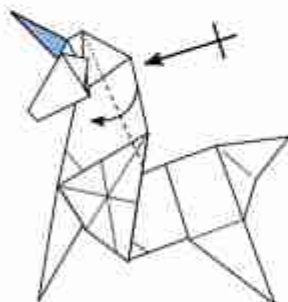

39. Fold just one layer.
Plegar solo una capa.

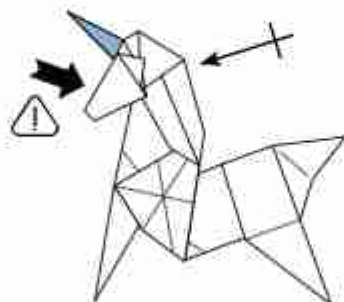

Note: Push to be sure that the head remains in the correct place.
Nota: Empujar para asegurarse que la cabeza se mantiene en el lugar correcto.

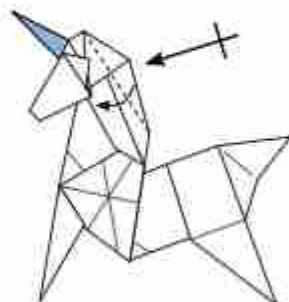

40. Fold the next layer, with a different angle.
Plegar la capa siguiente, en otro ángulo.

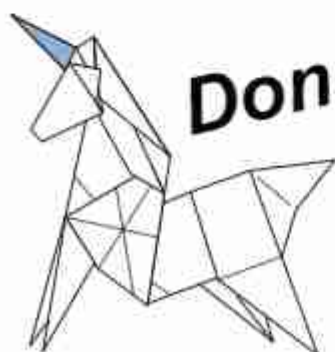

Done!

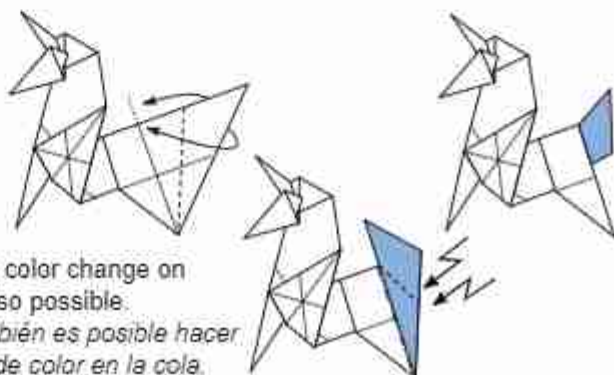

Annexed: a color change on the tail is also possible.
Anexo: también es posible hacer un cambio de color en la cola.

Dragon

Ary Fialho de Menezes

©2020 - Brazil

Intermediate

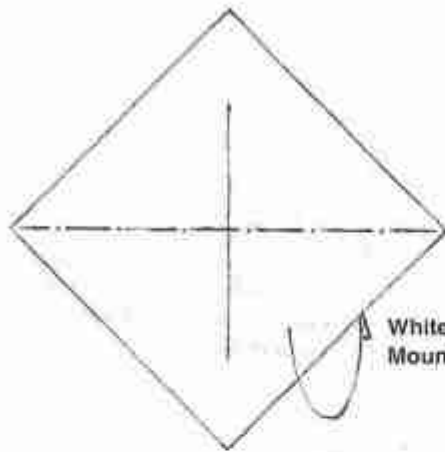

White side up.
Mountain fold.

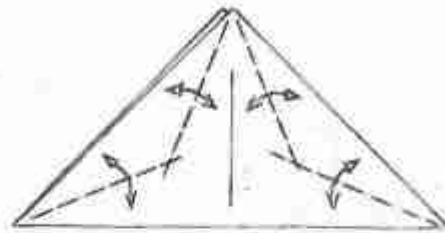

Valley fold.
Repeat behind.

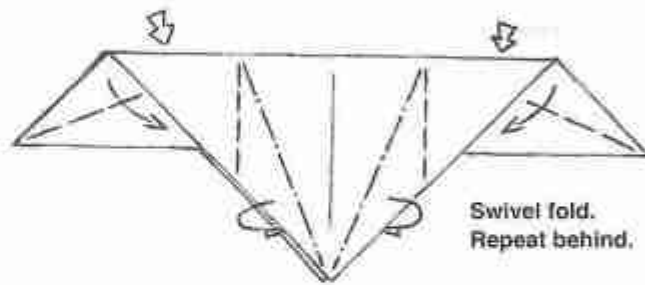
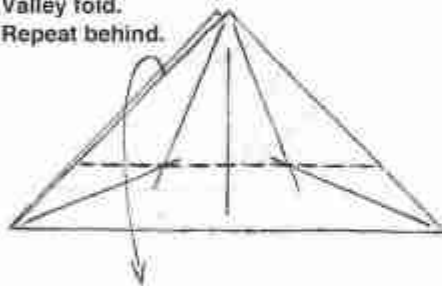

Swivel fold.
Repeat behind.

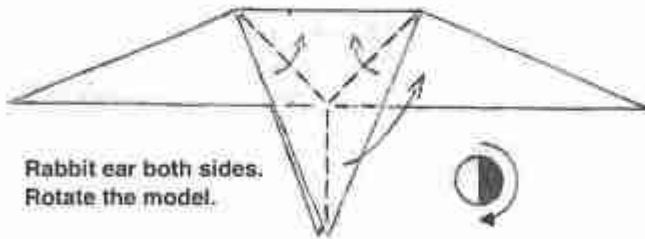

Rabbit ear both sides.
Rotate the model.



Crease sharply where indicated.

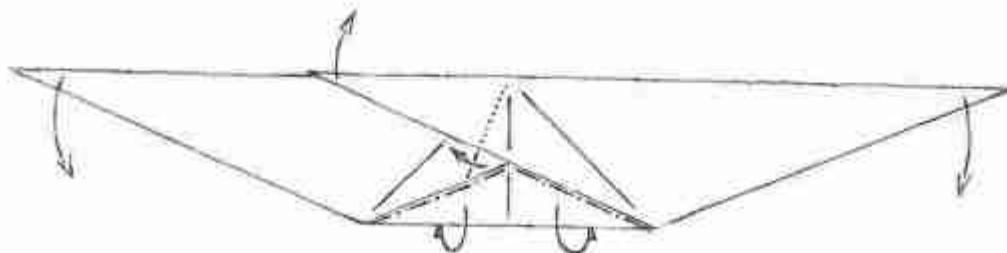

Crimp the sides down, starting with the mountain folds.
Incorporate the valley folds and adjust inside the model...

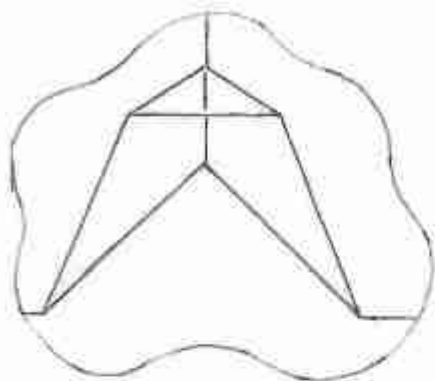

...As indicated on the inside.

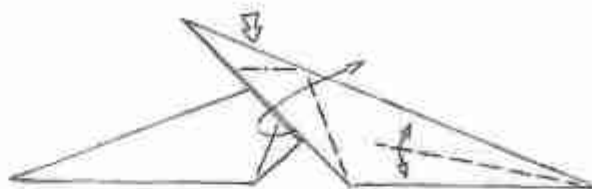

Squash fold the top flaps.
Precrease along the angle bisectors.

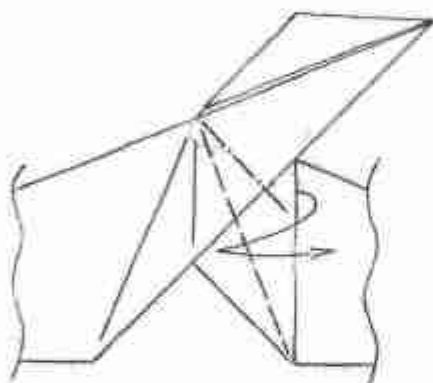

Swivel fold.

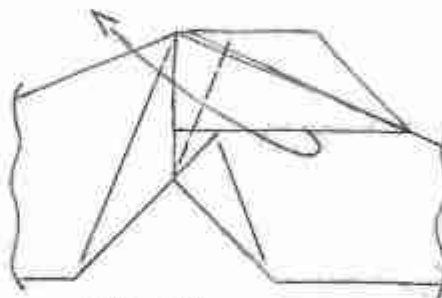

Valley fold.

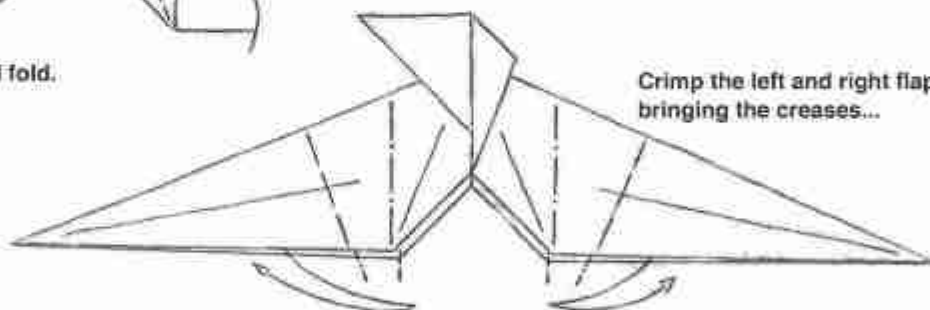

Crimp the left and right flaps,
bringing the creases...

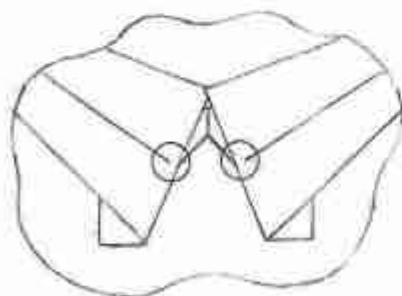

...To the inner points indicated.

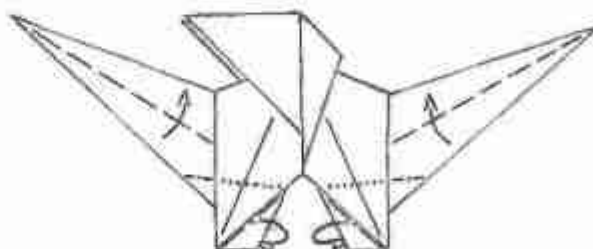

Swivel fold and repeat behind.

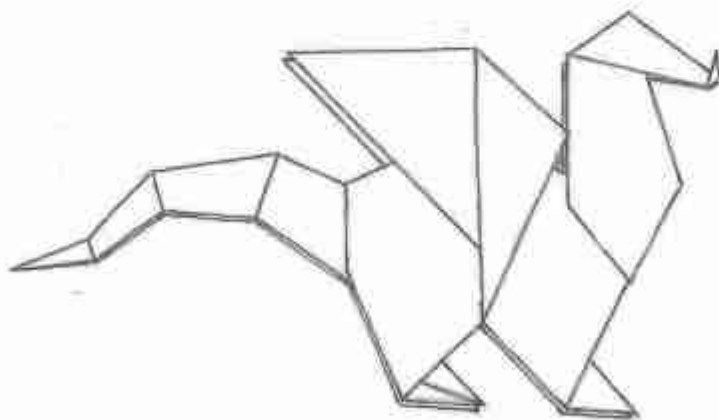
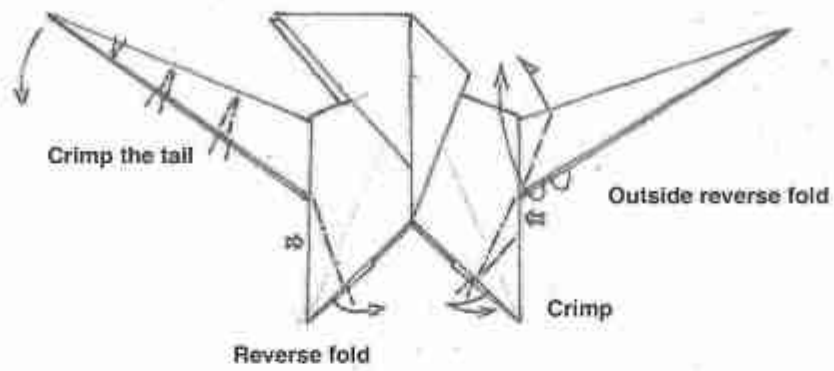

Triceratops Plane

Paul Frasco

©2022 - USA

Low Intermediate

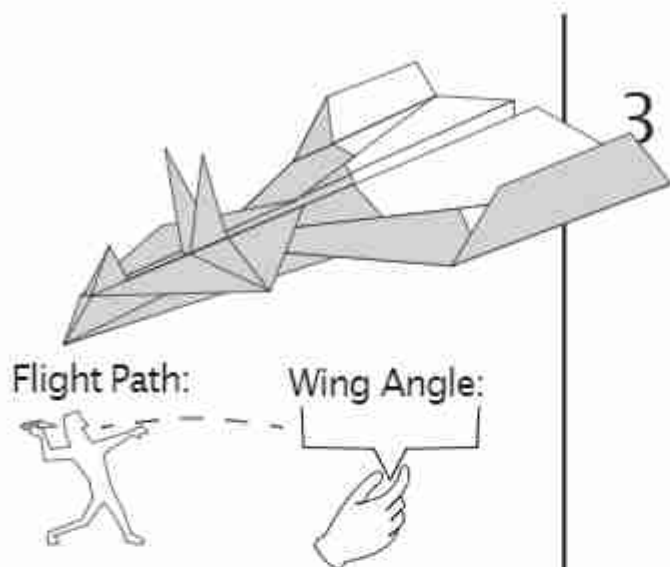

1

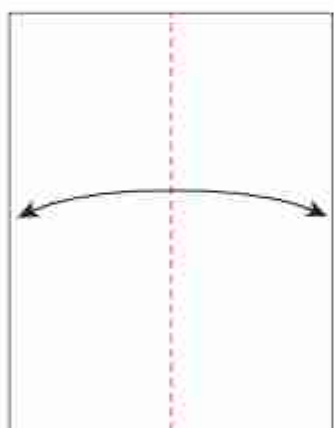

2

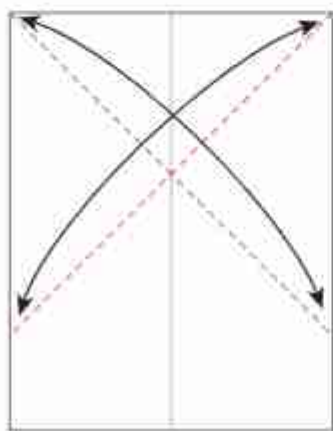

Turn over.



4

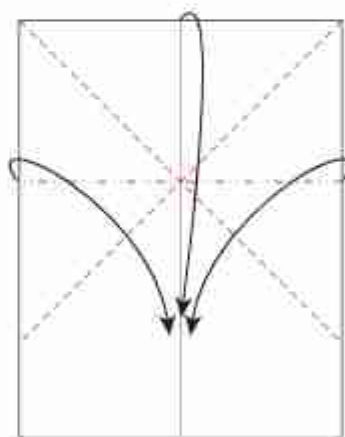

5



Turn over.



6

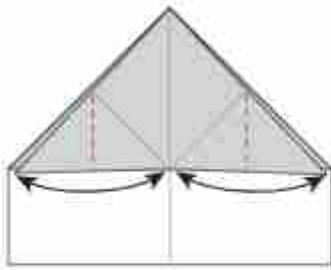

9

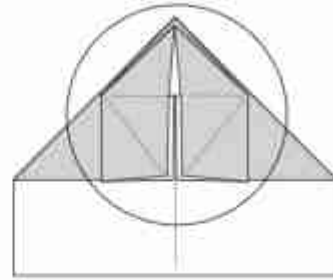

7

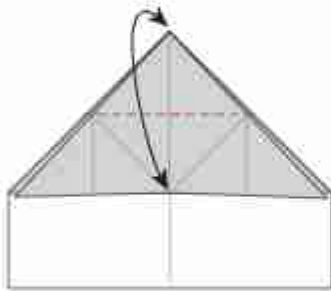

10

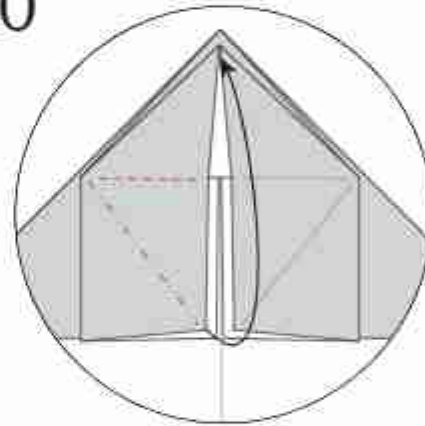

8

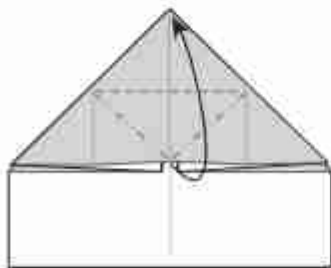

11

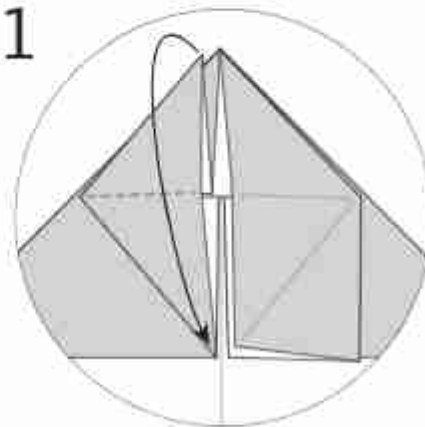

12

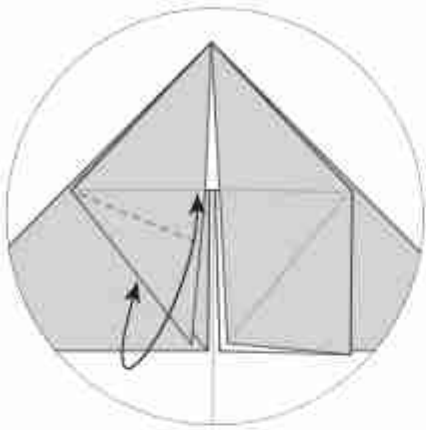

15

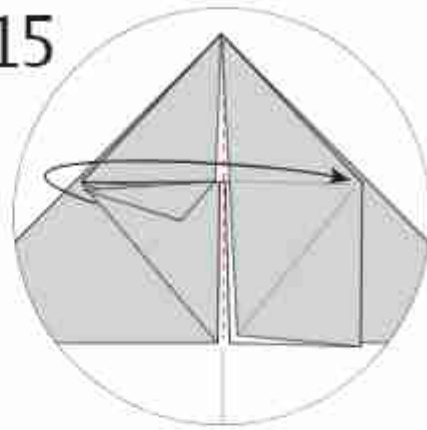

13

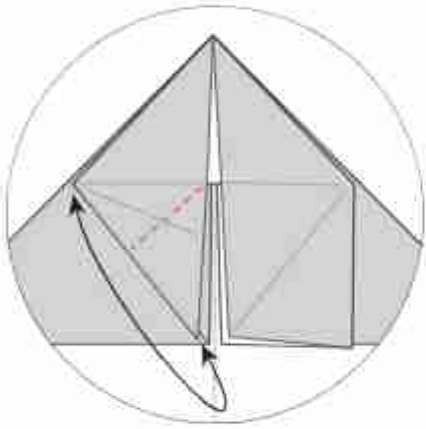

16

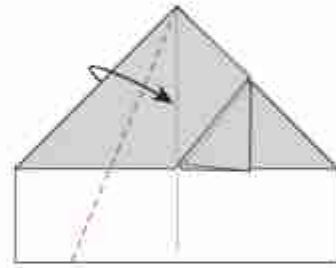

14

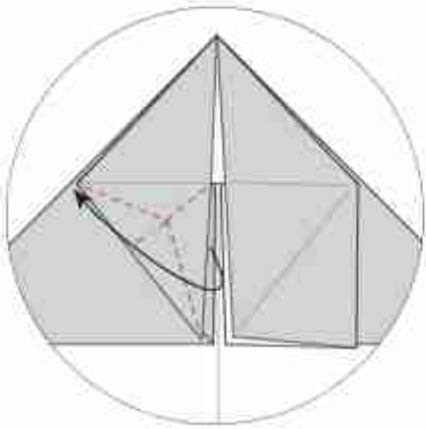

17

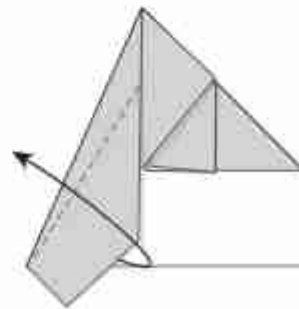

Rabbit Ear

18

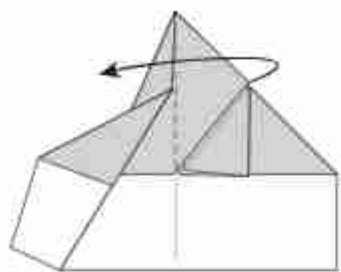

19

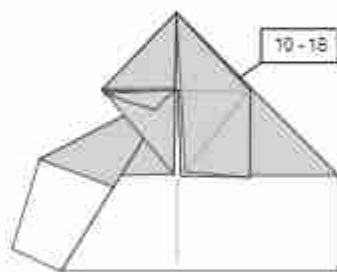

20

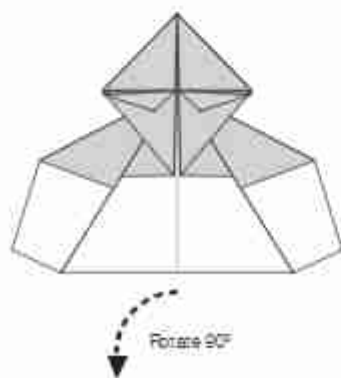

21

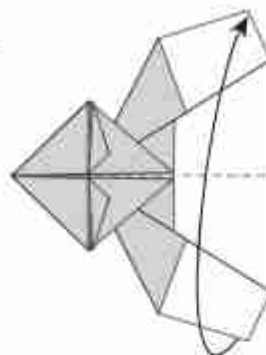

22

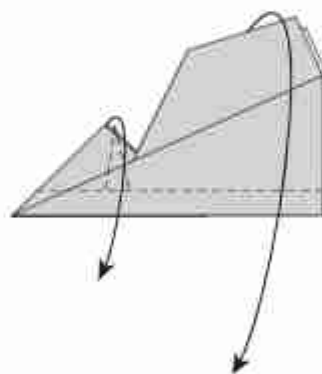

23

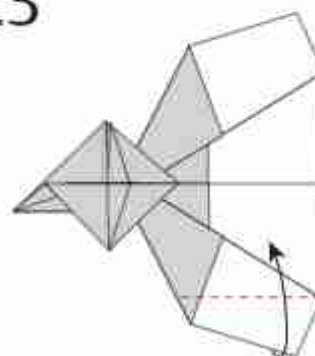

24

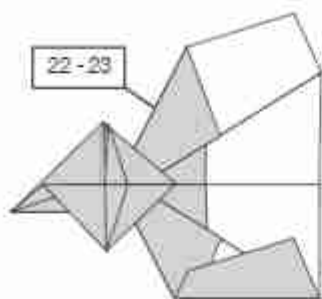

27

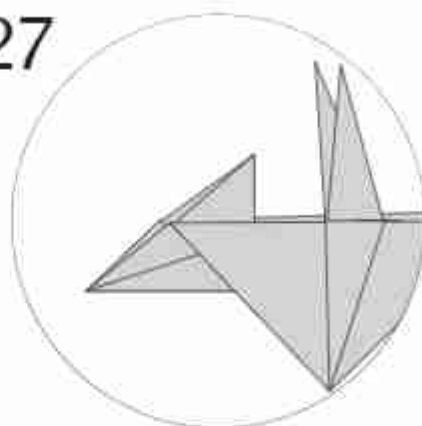

25

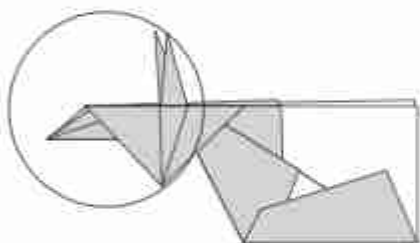

28

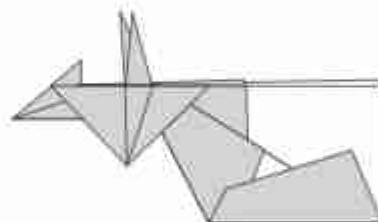

26

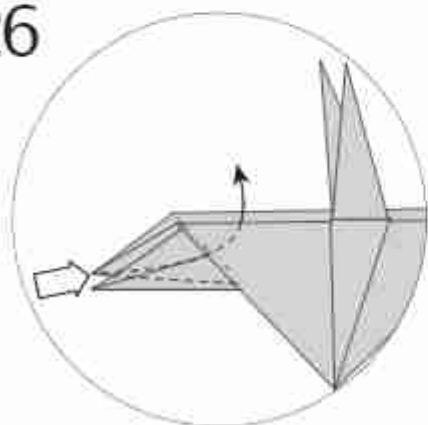

29

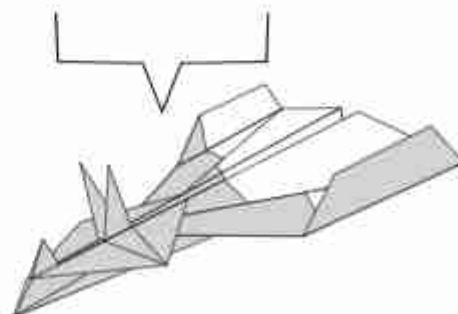

Intermediate

Size recommended: 15cm

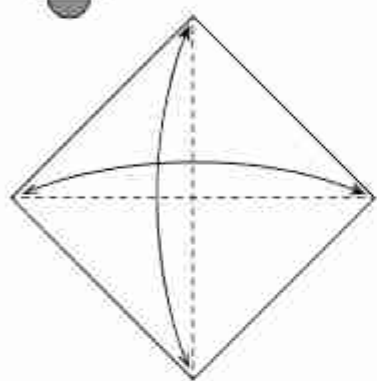
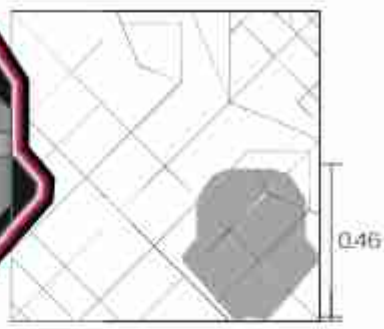

1. Fold and unfold.

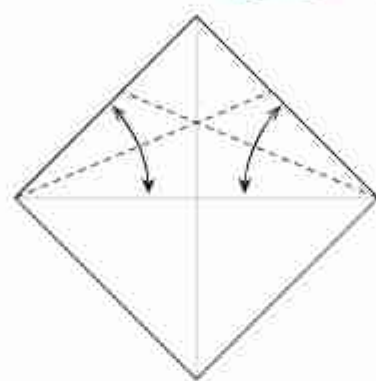

2. Fold and unfold.

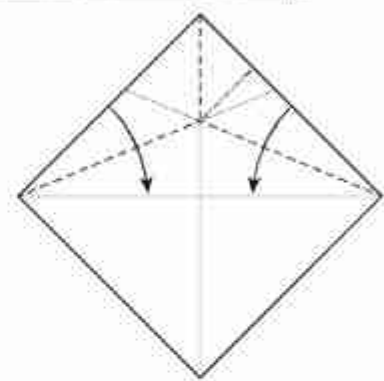

3. Rabbit ear fold.

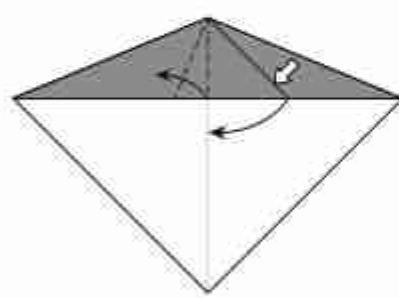

4. Squash fold.

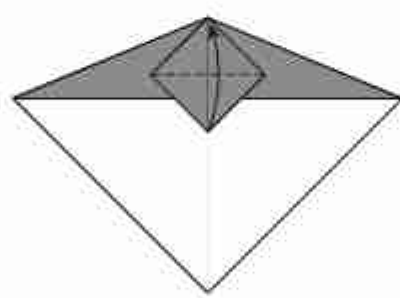

5. Valley fold.

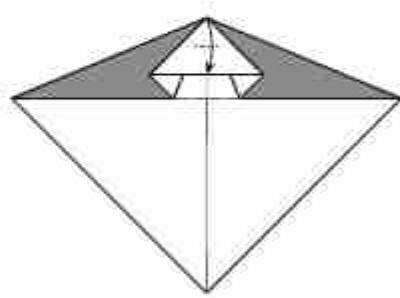

6. Make a pinch and keep hold of it.

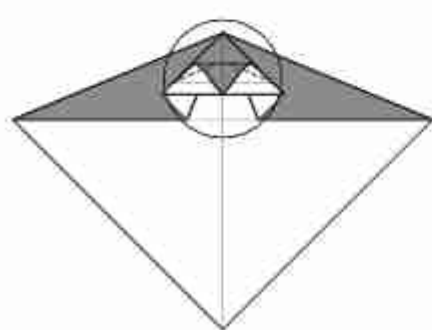

7. Zoom.

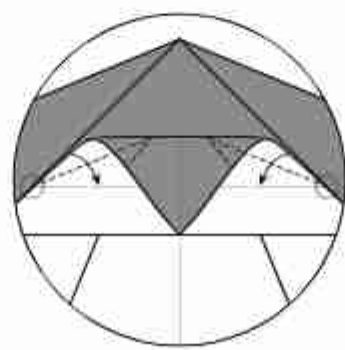

8. Swivel fold.

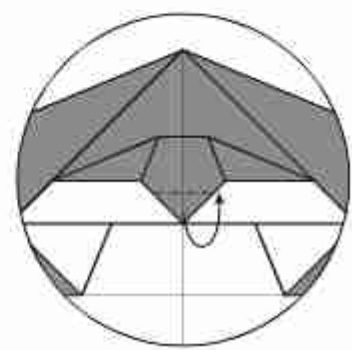

9. Mountain fold.

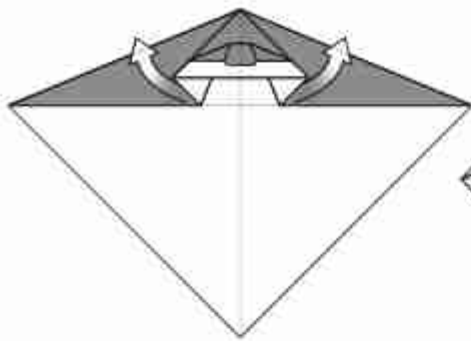

10. Unfold as shown.

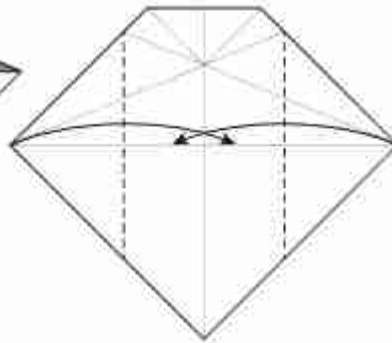

11. Valley folds.

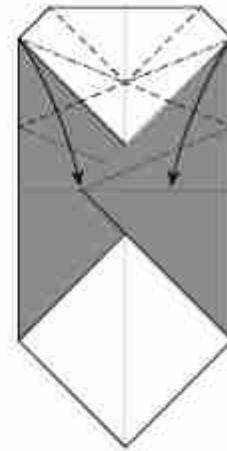

12. Refold top creases to step 8.

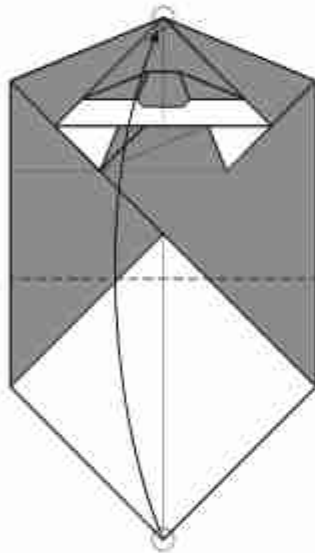

13. Valley fold.

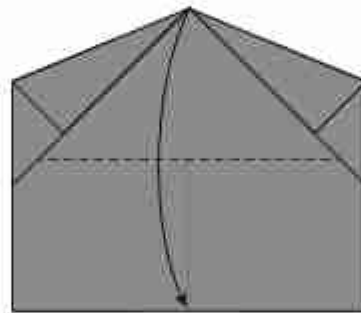

14. Valley fold.

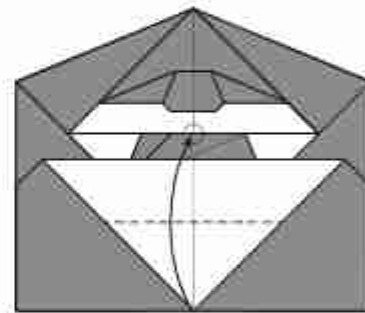

15. Valley fold.

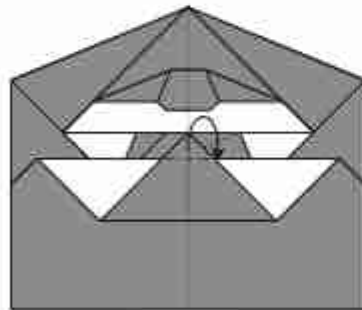

16. Mountain Fold.

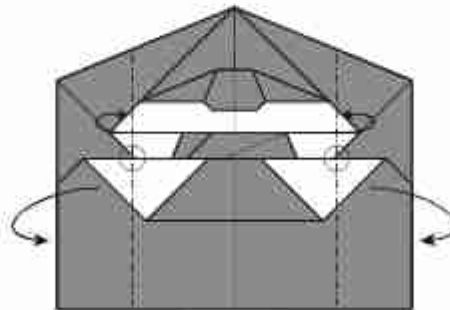

17. Mountain folds using reference points. Fold top corners under themselves.

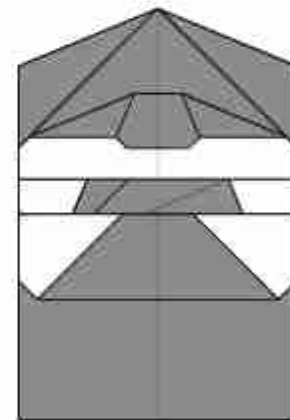

18. Refold top creases to step 8.

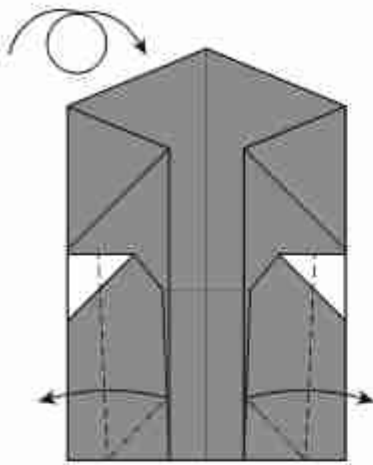

19. Squash folds.

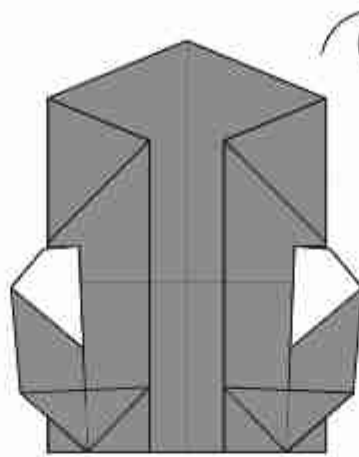

20. Turn over.

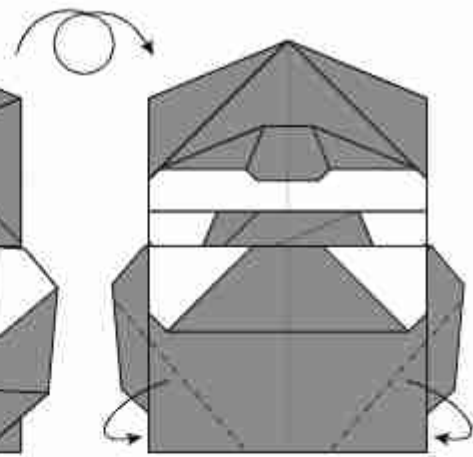

21. Mountain folds.

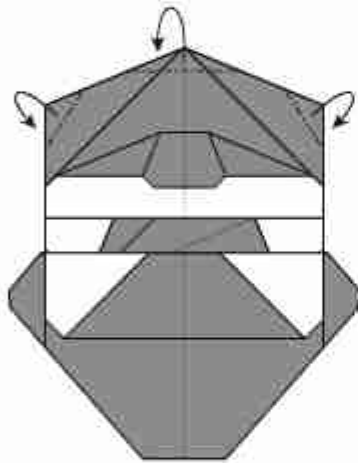

22. Shape the head with mountain folds.

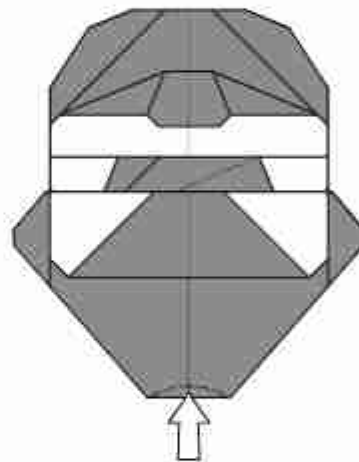

23. Shape the chin.

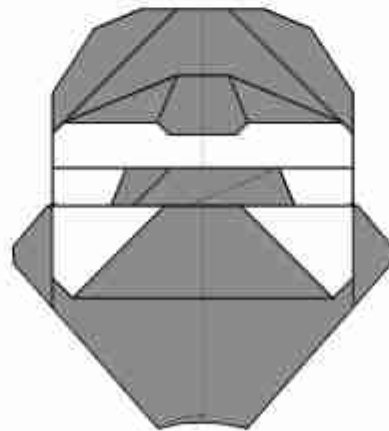

Model finished.

Shining Octagon

Mahyar Hossien Khani

©2020 - Iran

Intermediate

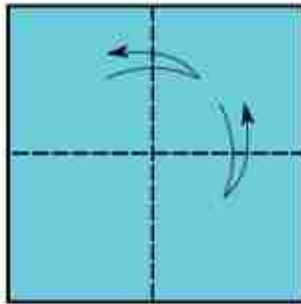

1-  start with a square and fold and unfold along the lines

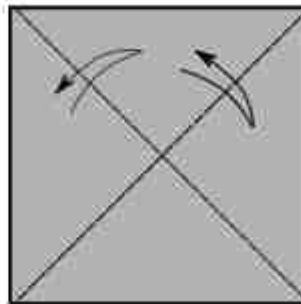

2- 

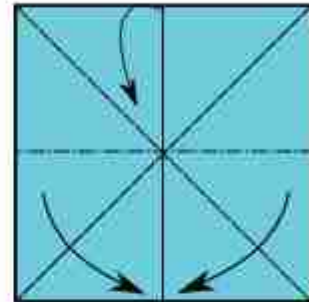

3-

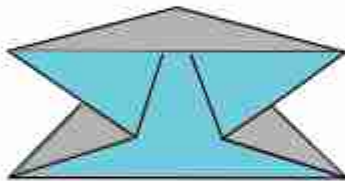

4-

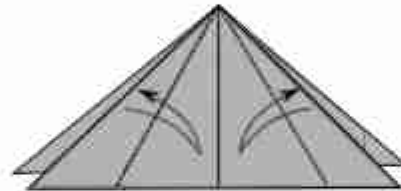

5-



6- Fold the flap back down

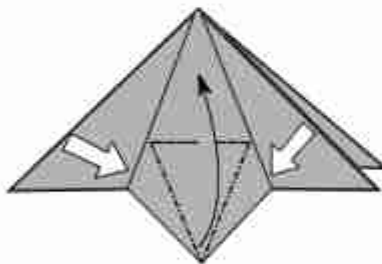

7- Petal fold the corner

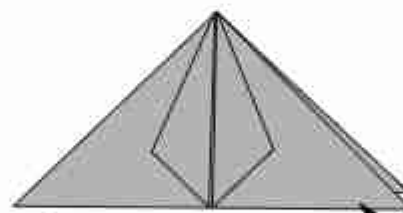

8- repeat step 6 and 7

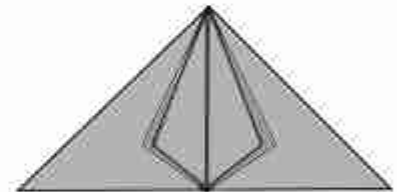

9-

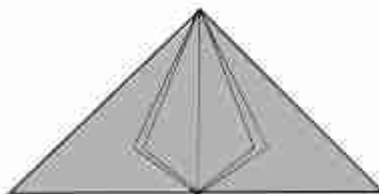

10- open the back

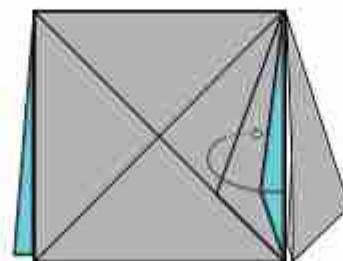

11- color change

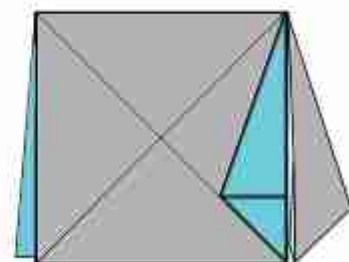

12-

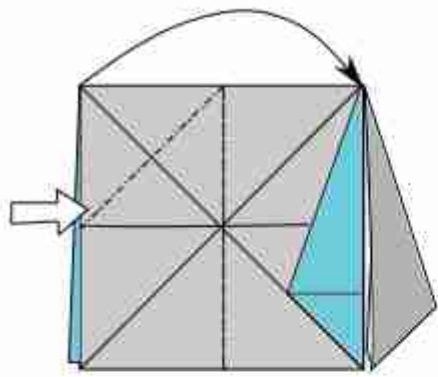

13 *squash fold*

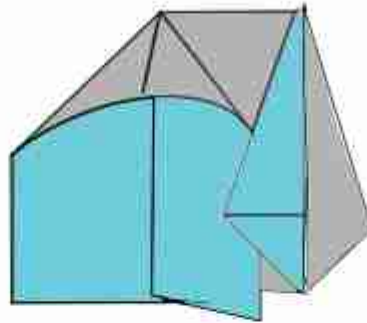

14

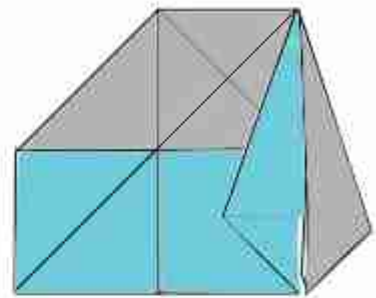

15 *the result*

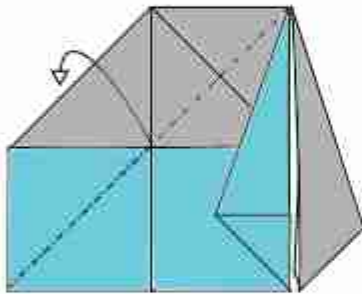

16 *fold it behind*

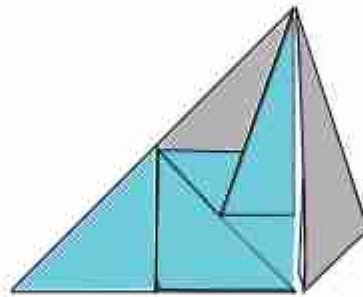

17 *the result*

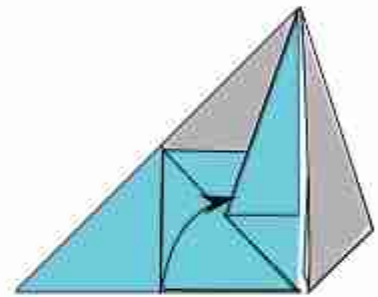

18

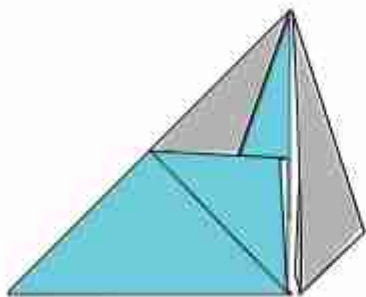

19- 8x

Assembly

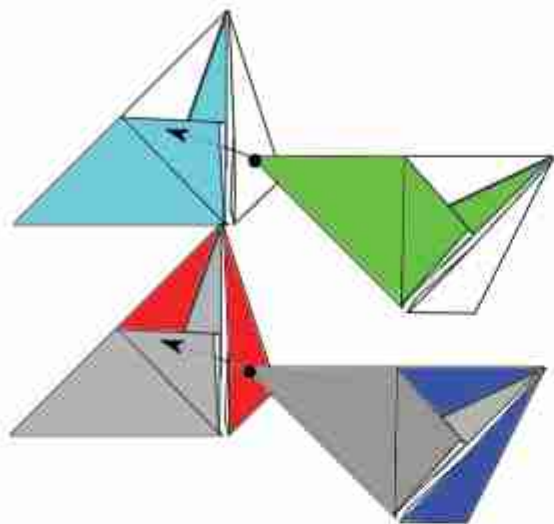

Hippo

Intermediate

Marc Kirschenbaum

©2015 - USA

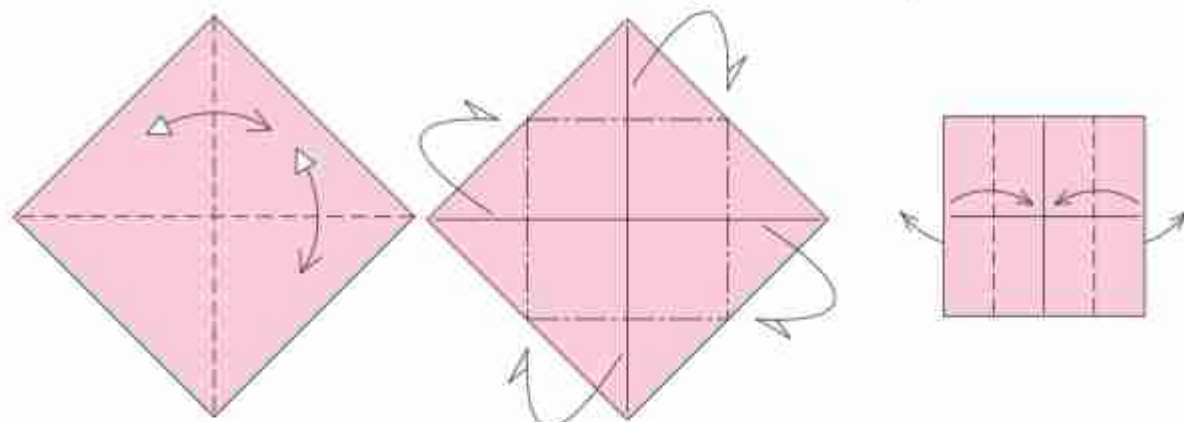

1. Precrease along the diagonals.

2. Mountain fold the four corners.

3. Fold the sides inward, allowing the flaps from behind to swing forward.

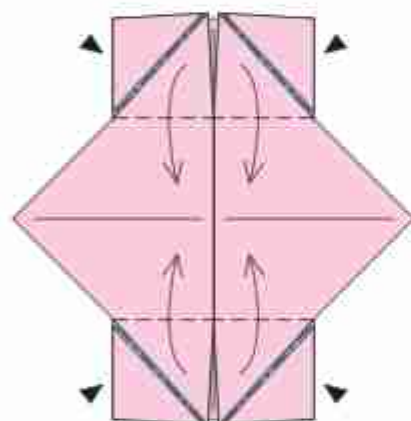

4. Squash the four corners inward.

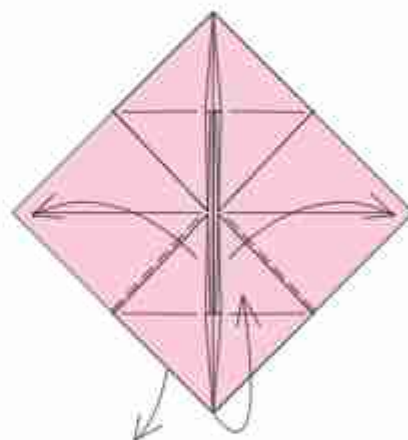

5. Stretch the flaps towards the outer corners, allowing the flap from behind to come to the front.

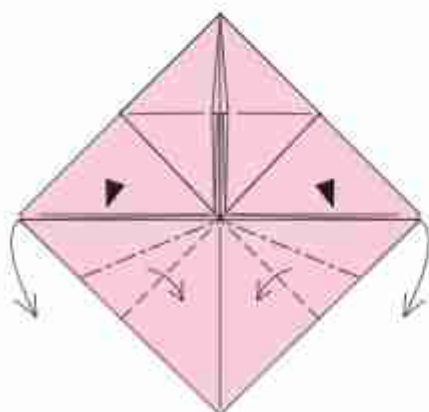

6. Squash fold the flaps.

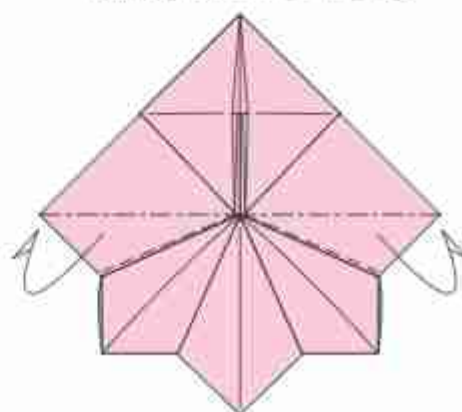

7. Mountain fold the flaps behind in half, allowing some paper to slide from behind the lower flaps.

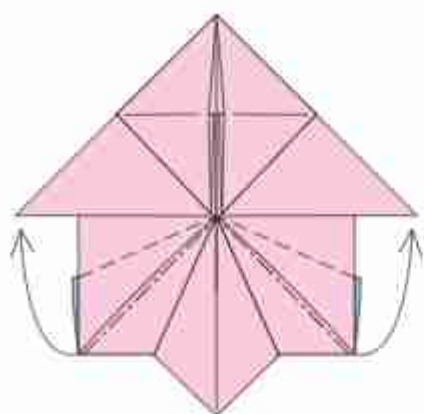

8. Pull the lower flaps towards the upper flaps, squashing them flat.

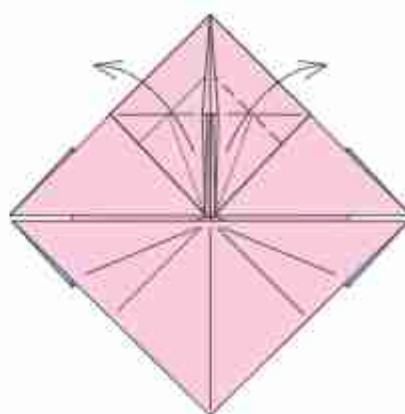

9. Valley fold the flaps outwards, allowing squash folds to form.

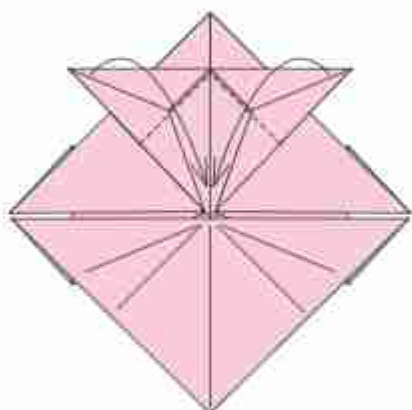

10. Swing the flaps back down.

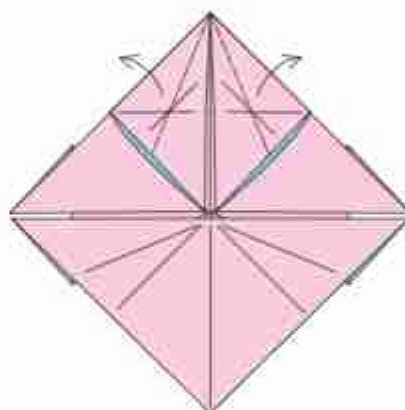

11. Squash fold the flaps.

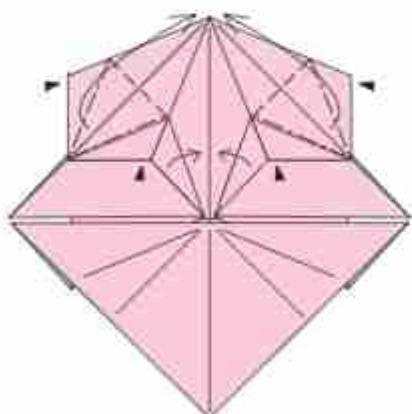

12. Petal fold the flaps to the top.

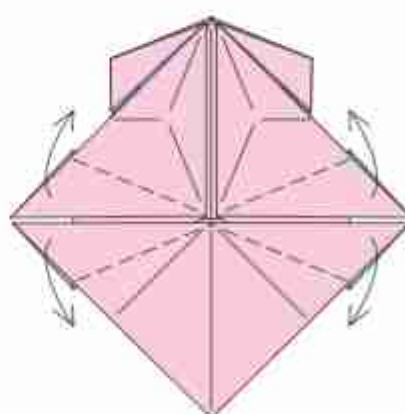

13. Valley fold the flaps outwards.

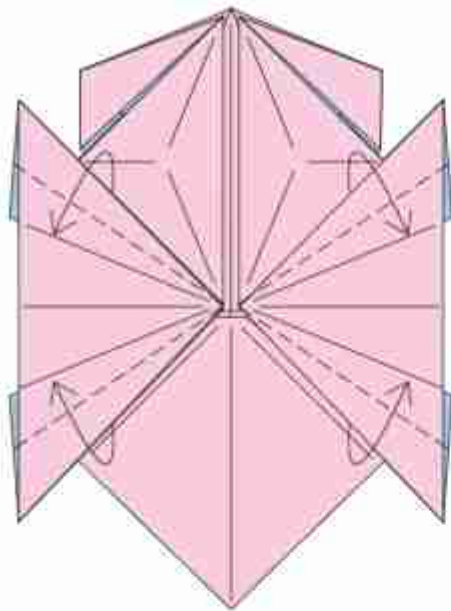

14. Valley fold to the creases:

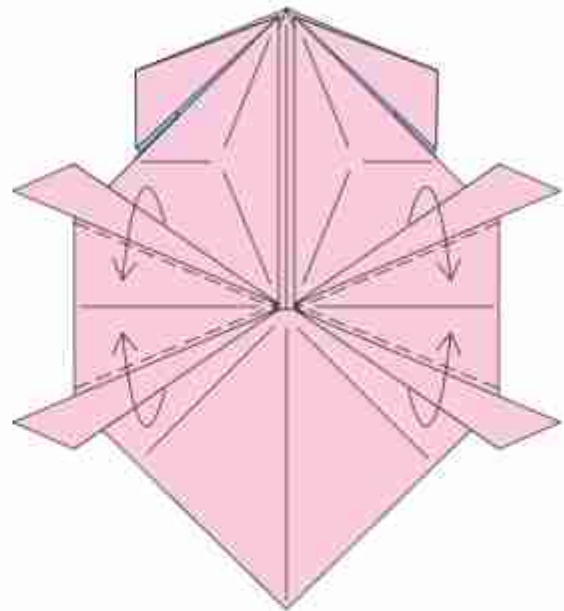

15. Valley fold along the existing creases:

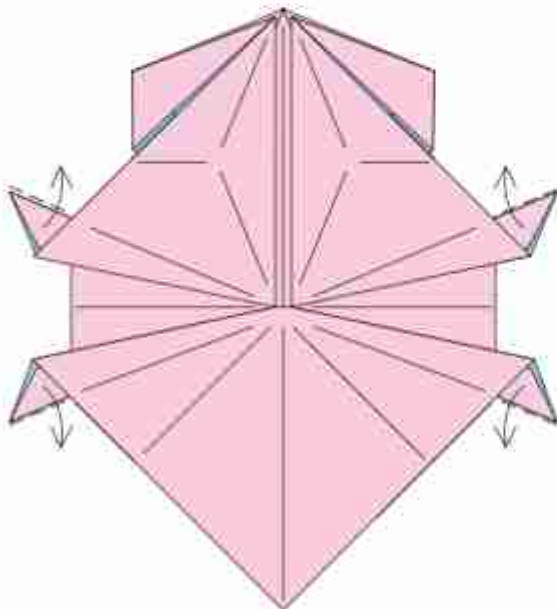

16. Valley fold the trapped single layers outwards on each flap.

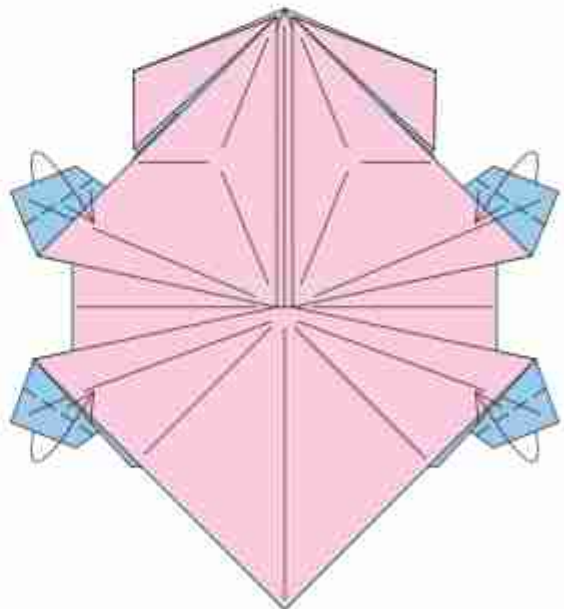

17. Valley fold the edges inwards.

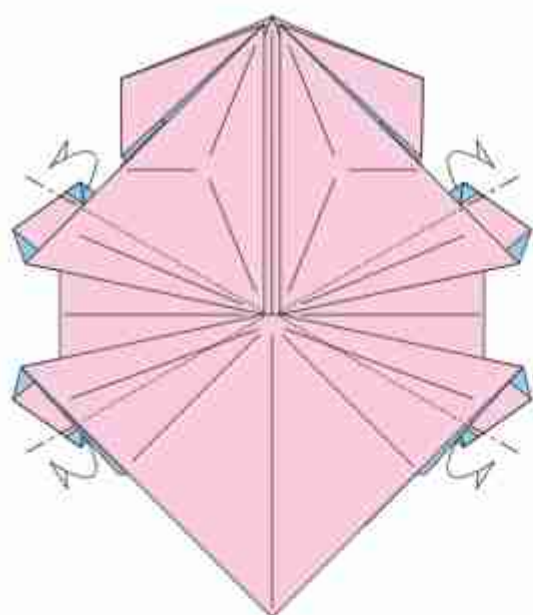

18. Mountain fold the edges behind at each flap.

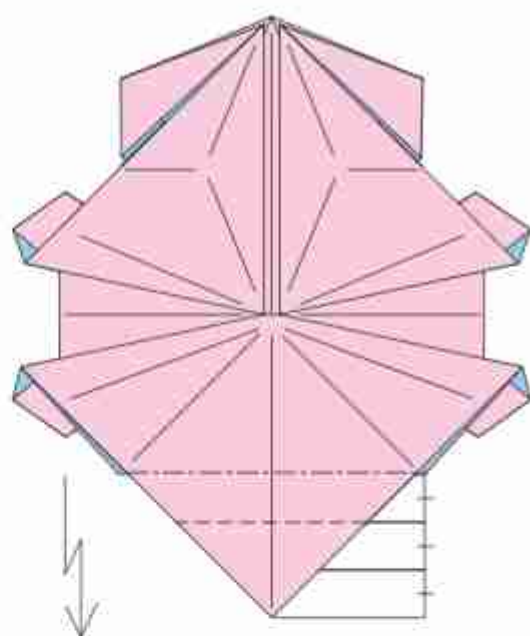

19. Pleat the lower corner.

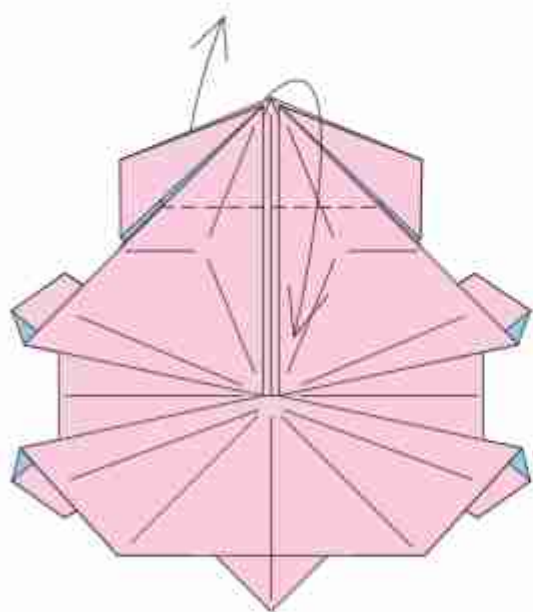

20. Valley fold the top section down, allowing the flap from behind to come forward.

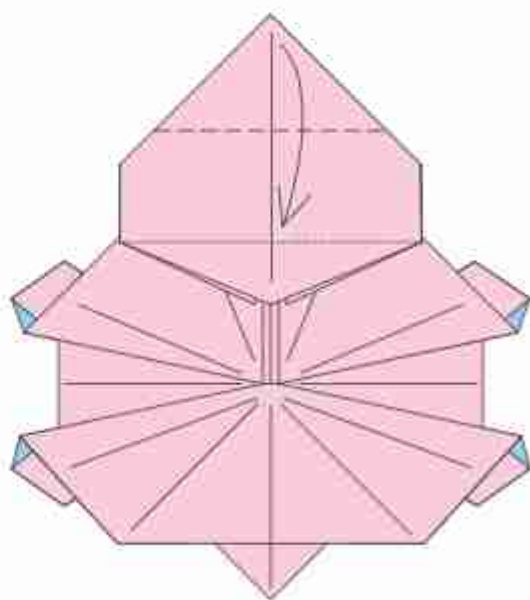

21. Valley fold the corner to the hidden edge.

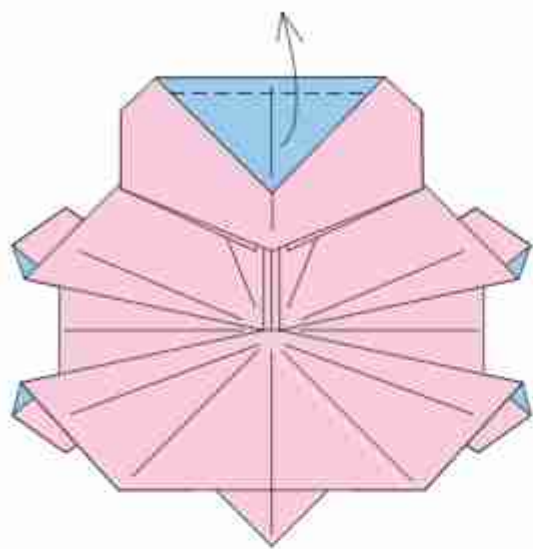

22. Valley fold the flap up.

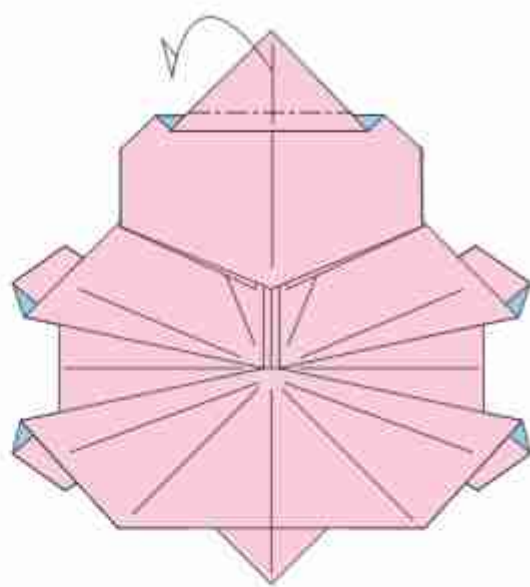

23. Mountain fold the flap.

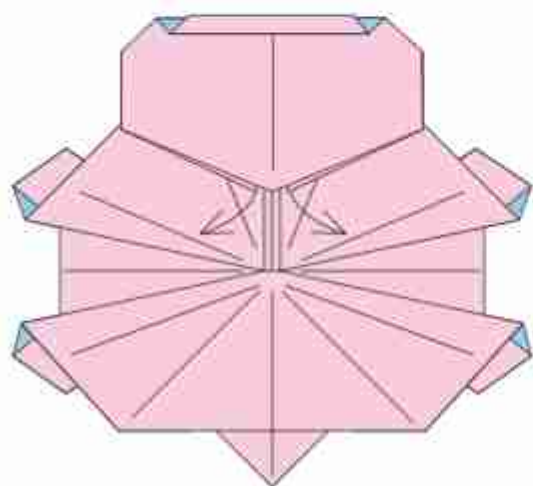

24. Pull the hidden flaps outwards.

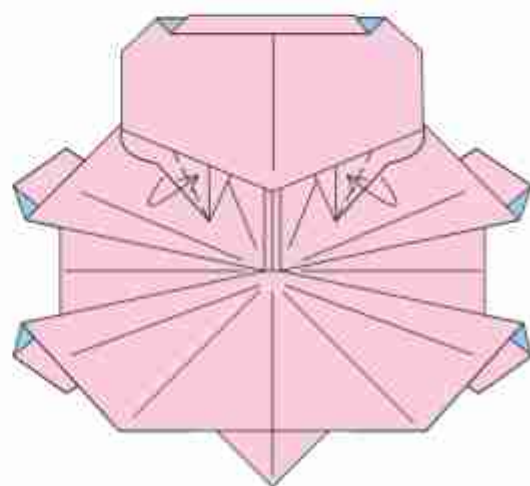

25. Valley fold the edges inwards, allowing the flaps to flatten.

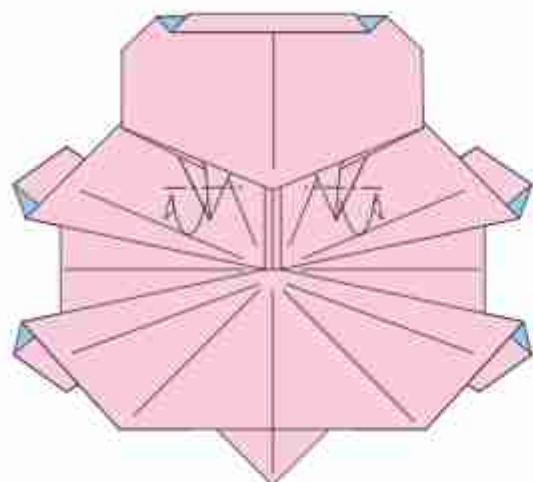

26. Mountain fold the corners.

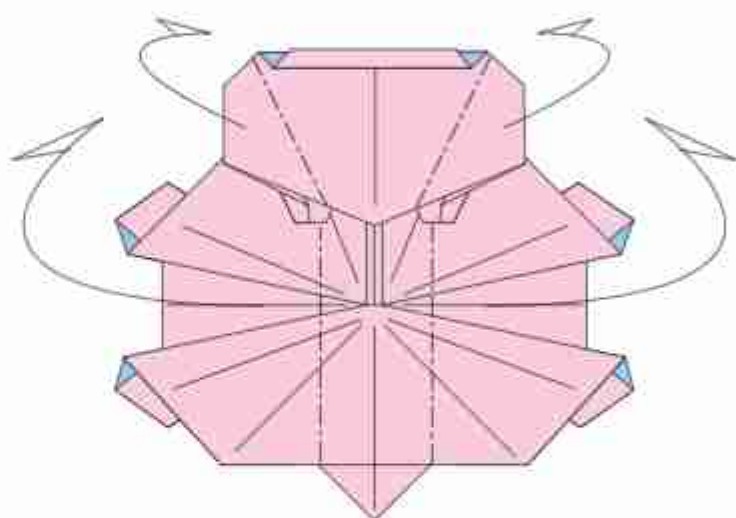

27. Mountain fold the sides behind.

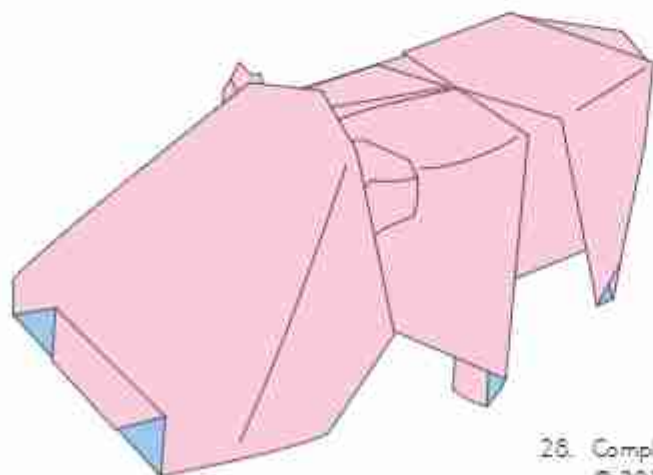

28. Completed Hippo.
© 2015 Marc Kirschenbaum

Ghost

Intermediate

Hiroaki Kobayashi

©2020 - Japan

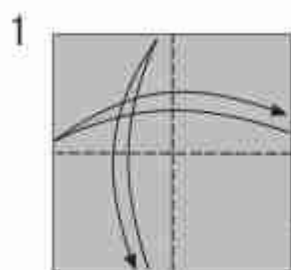

フチとフチを合わせて
折り筋をつける

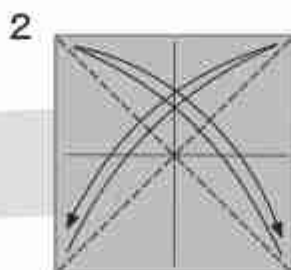

カドとカドを合わせて
折り筋をつける

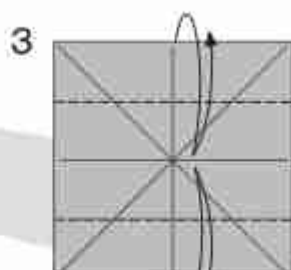

フチと折り筋を合わせて
折り筋をつける

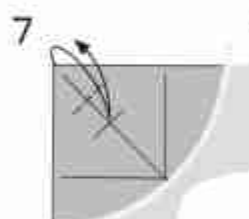

カドと折り筋を合わせて
折り筋をつける

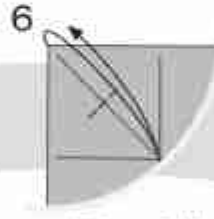

カドとフチを合わせて
折り筋をつける

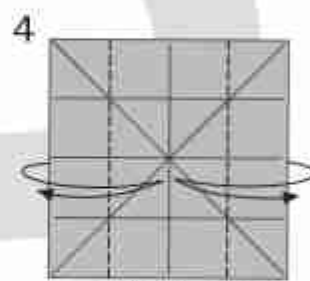
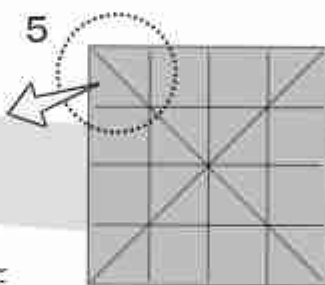

フチと折り筋を合わせて
折り筋をつける

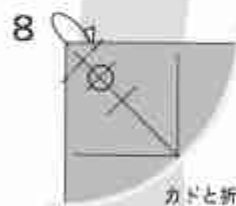

カドと折り筋を
合わせて山折り

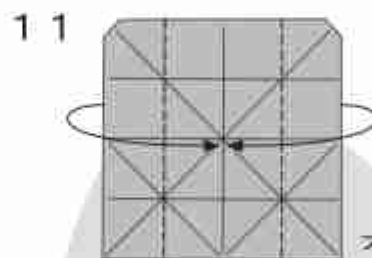

フチを折り筋に合わせて折る

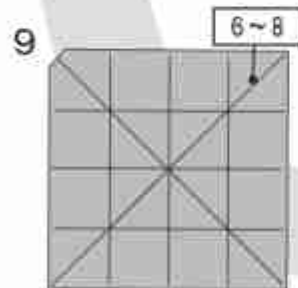

反対側も6~8と同様に折る

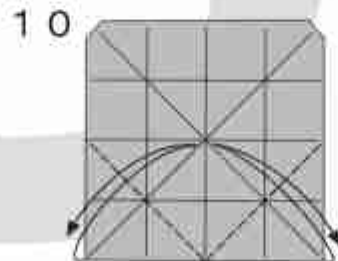

カドとフチを合わせて
折り筋をつける

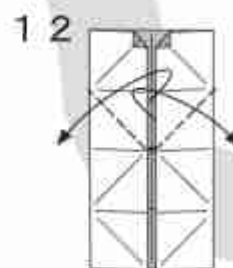

フチを折り筋に合わせて折る

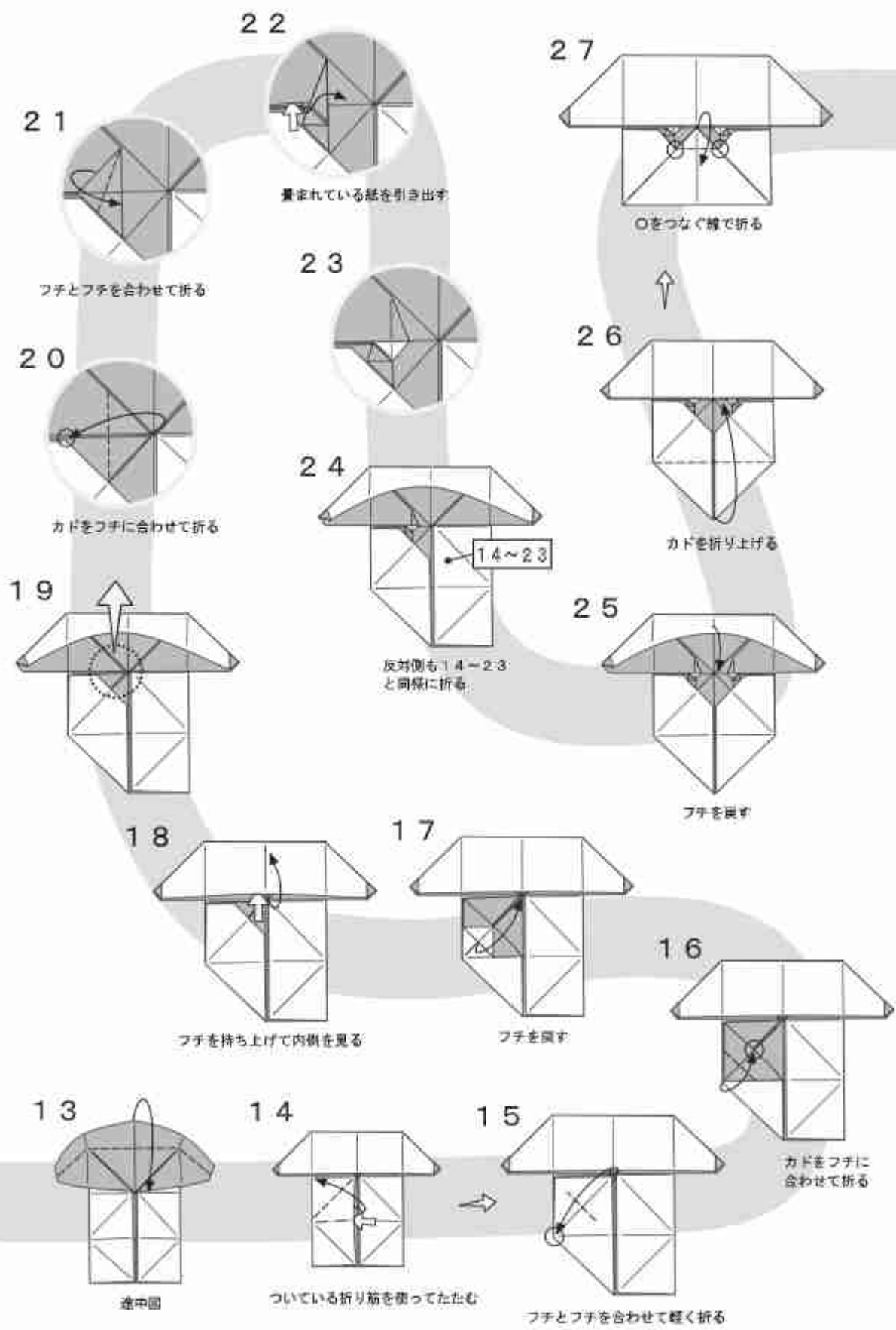

28

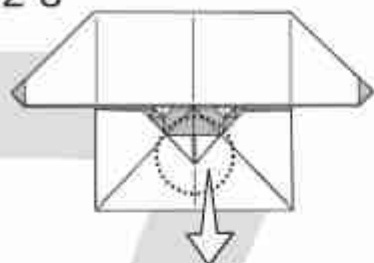

29

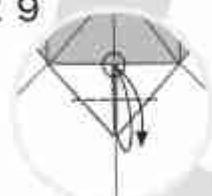

カドとフチを合わせて
折り筋をつける

30

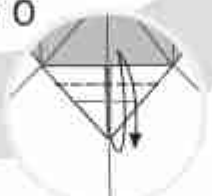

半分の幅で折り筋をつける

31

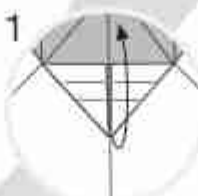

27の状態に戻す

32

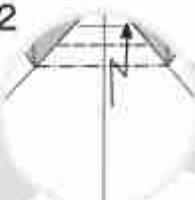

ついている折り筋で
殺折り

33

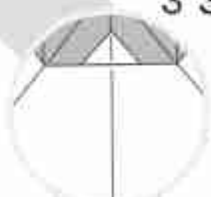

34

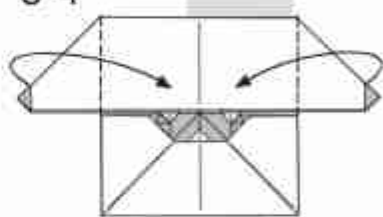

ついている折り筋で折る

35

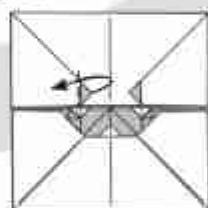

フチに沿って折る

36

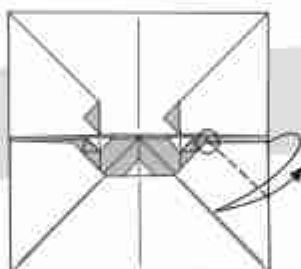

カドをフチに合わせて
折り筋をつける

37



カドを山折り

39

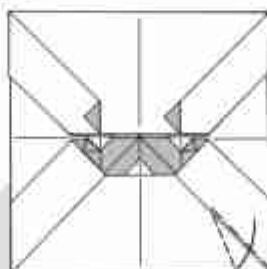

つまむように折る
立体的になる

40

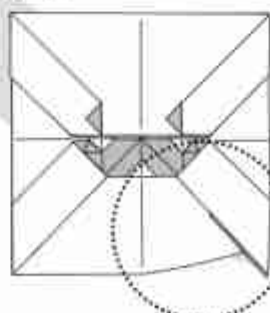

裏側から見る

38

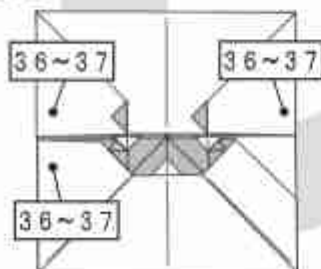

残り3つのカドも
36~37と同様に折る

4 8

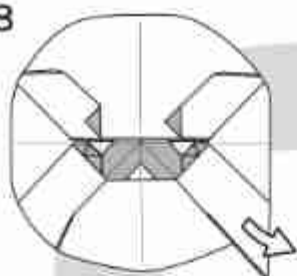

全体に丸みをつける

4 9

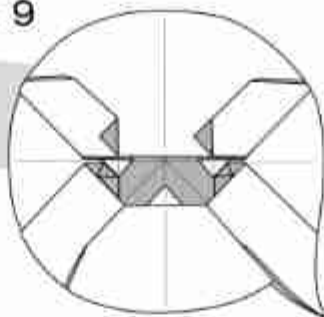

完成

45~46

4 7

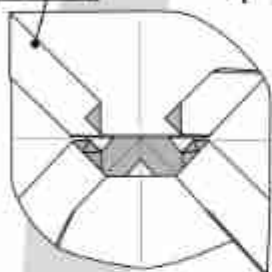

反対側も45~46と同様に折る

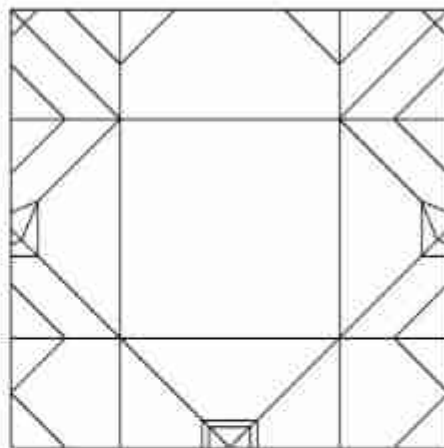

4 6

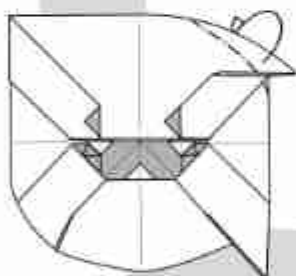

後ろに折り込む

4 5

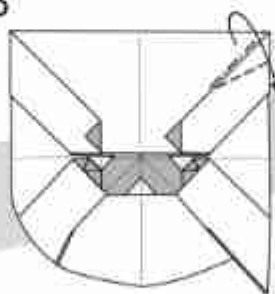

つまむように折る

4 4

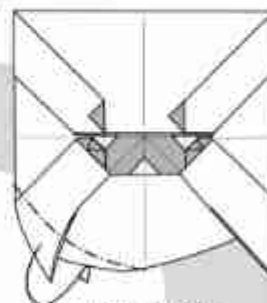

後ろに折り込む

4 1

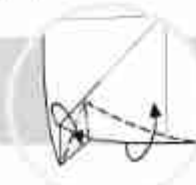

引き寄せ折り

4 2

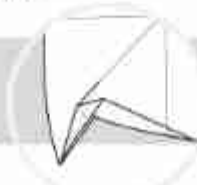

4 3

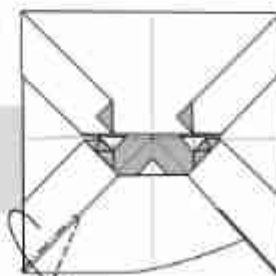

つまむように折る

Hummingbird

Matt LaBoone

©2022 - USA

Intermediate

Ratio: .68 head to tail Color Change: Yes
Fold Time: 35 minutes
Paper: Medium; Kami
Recommended size: 6 inch square for 4 inch model

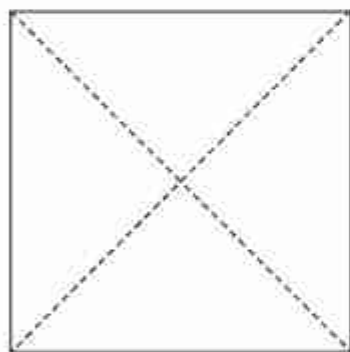
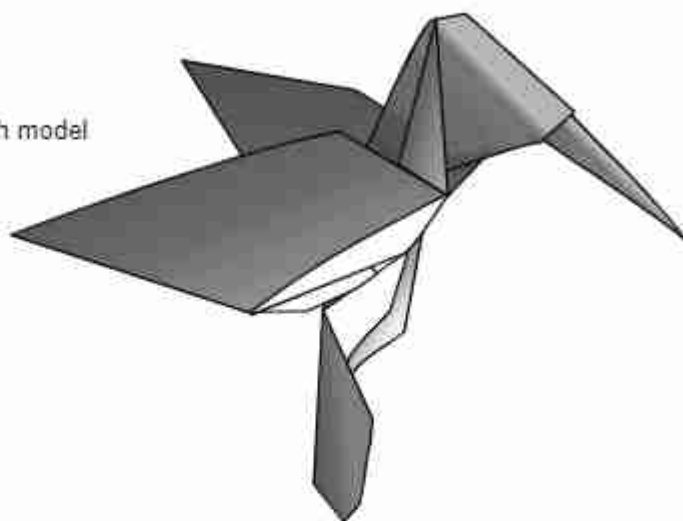

1. Valley fold the diagonals (white side up).

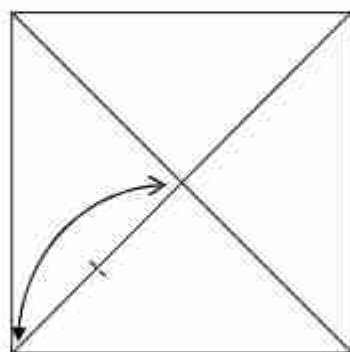

2. Pinch the indicated point.

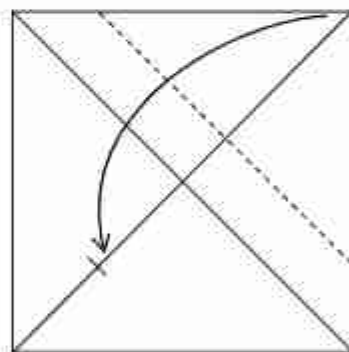

3. Valley fold the corner to the pinch.

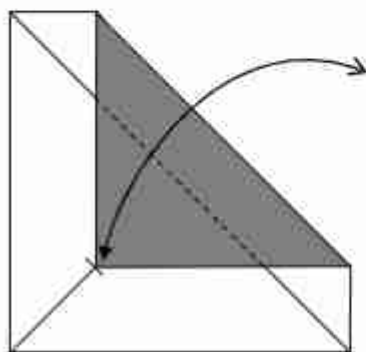

4. Fold and unfold the corner to line up with the centerline below.

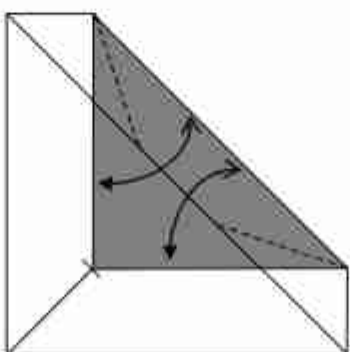

5. Valley fold the angle bisectors to meet the crease from step 4.

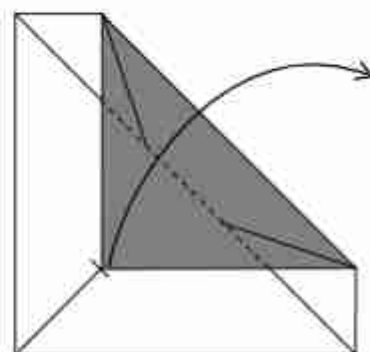

6. Valley fold the corner on the crease from step 4.

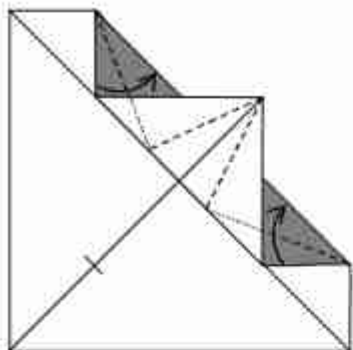

7. Re-fold the valley folds from step 5, swivel folding the flaps to meet the point that will be the beak.

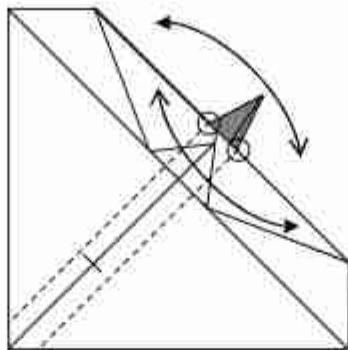

8. Fold and unfold diagonally where the point behind meets the layer in front.

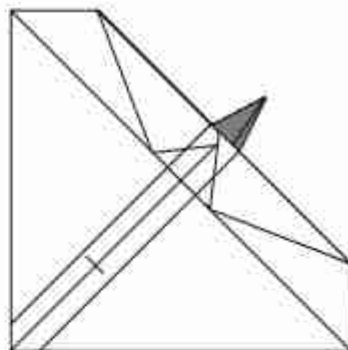

9. Turn the paper over.

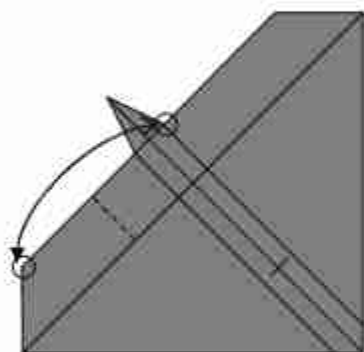

10. Valley fold so that the indicated points meet.

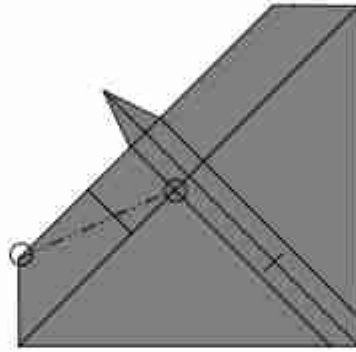

11. Mountain fold between the indicated points.

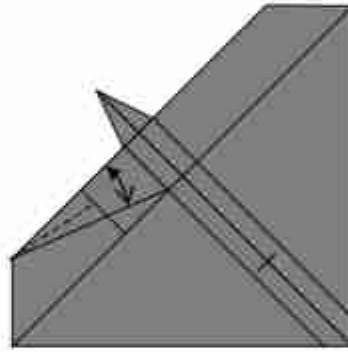

12. Valley fold the angle bisector to meet the fold from step 10.

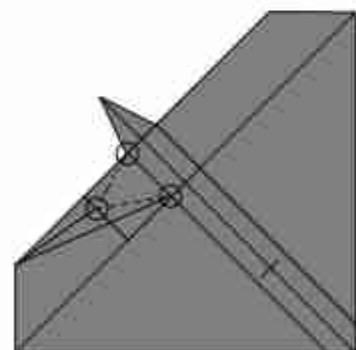

13. Crease between the indicated points.

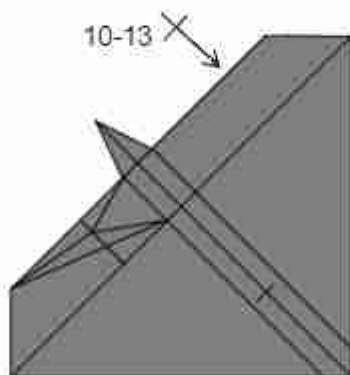

14. Repeat steps 10-13 on the right.

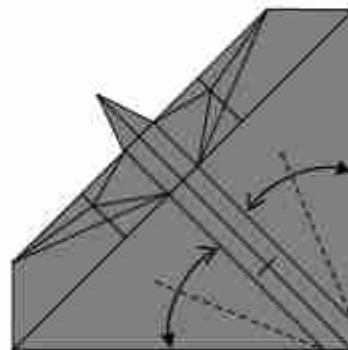

15. Valley fold and unfold the angle bisectors approximately as far as shown.

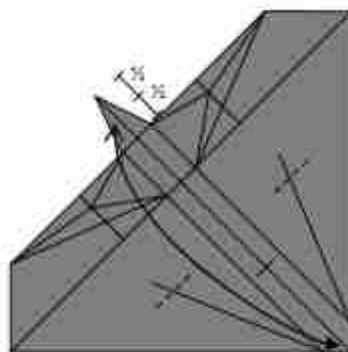

16. Valley fold the bottom right point to approximately halfway up the beak and pinch where the crease meets the folds from step 15.

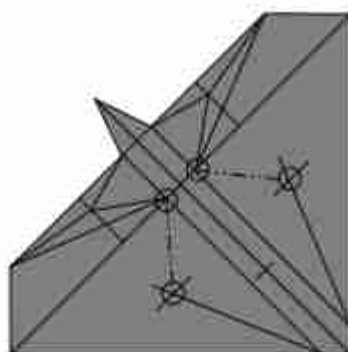

17. Mountain fold between the indicated points.

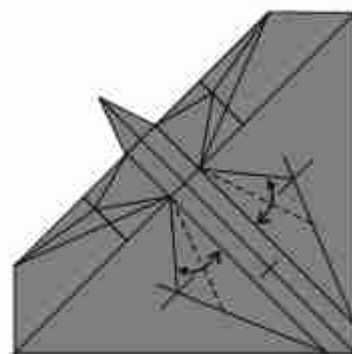

18. Valley fold the angle bisectors.

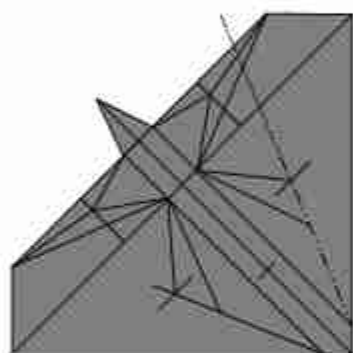

19. Mountain fold the right side of the paper behind on the existing crease from step 15. Do not crease the rest of the fold, the model will not lie flat.

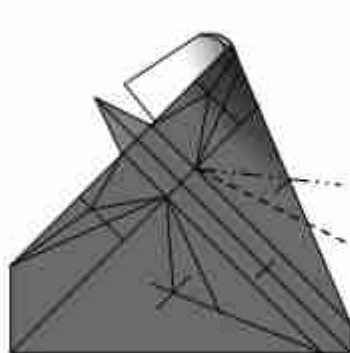

20. Fold and unfold on existing creases to extend to the layer behind.

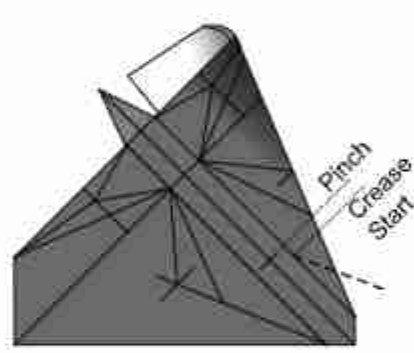

21. Crease approximately as shown through both layers. This crease begins slightly lower on the body than the pinch from step 2. This will be used later to shape the tail. Unfold to step 19.

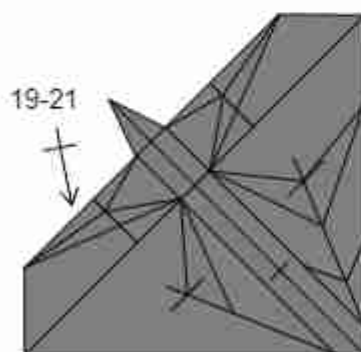

22. Repeat steps 19-21 on the left.

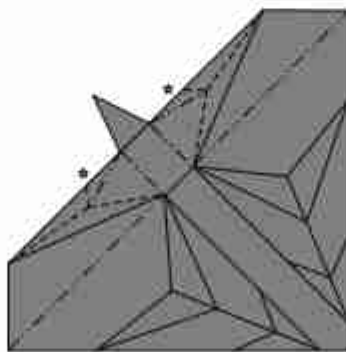

23. Extra lines removed for clarity. Collapse the model on the indicated folds, creating small valley folds at the indicated area. The model will no longer lie flat.

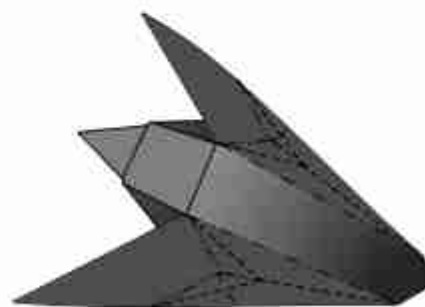

24. Collapse on existing creases. See the next step for an additional view.

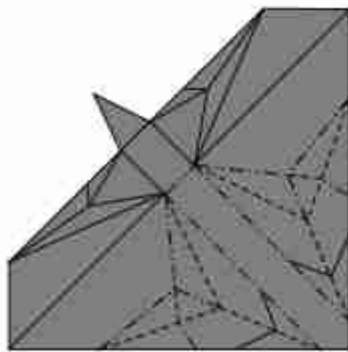

25. Creases shown on the flattened model.

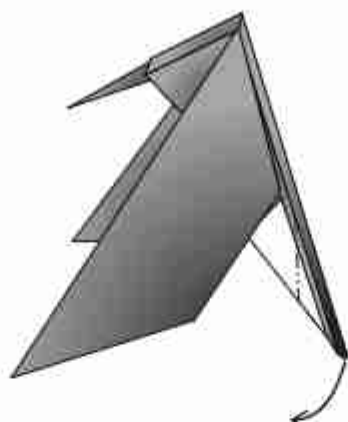

26. Shift the mountain folds on both sides of the tail to the creases made in step 21.

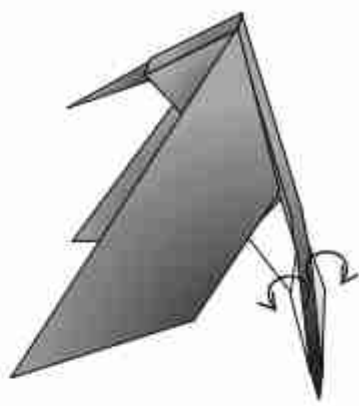

27. Wrap the white layers of tail around on both sides. This will lock the tail in place.

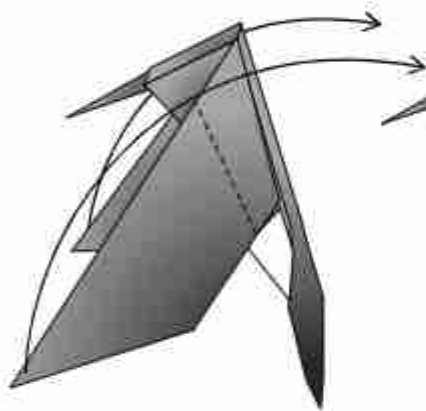

28. Fold the wings back as far as they will go, approximately as shown.

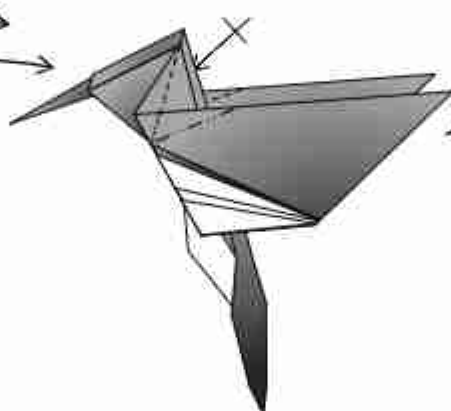

29. Inside reverse fold where the top of the wing meets the head. Repeat behind.

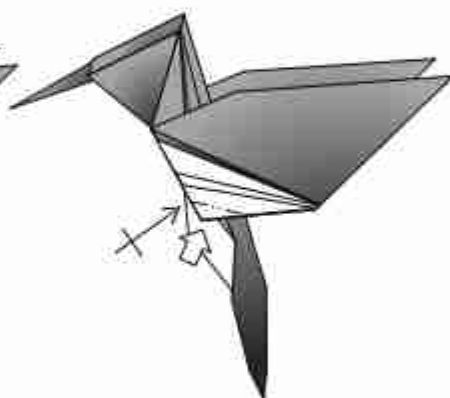

30. Inside reverse fold to shape the bottom of the wing. Repeat behind.

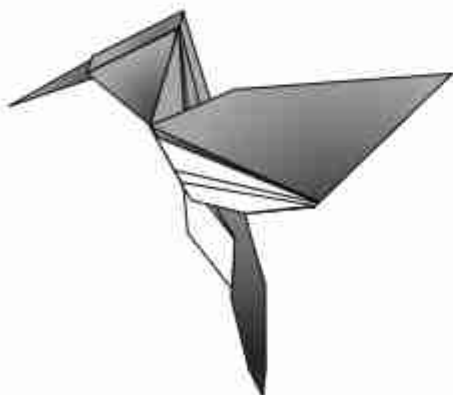

31. Round the beak and the sides of the head, softening the mountain folds.

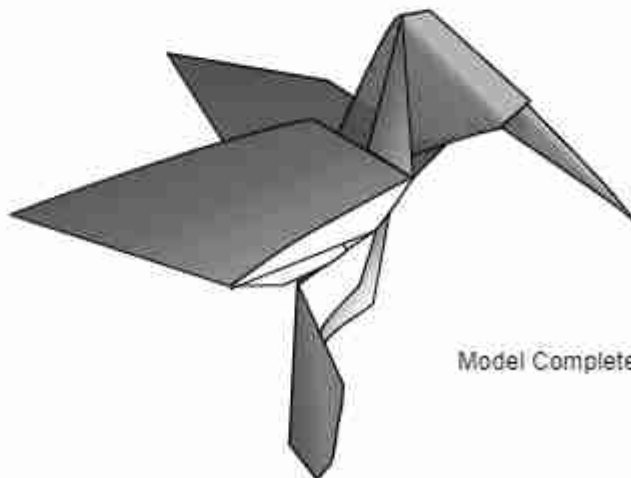

Model Complete

Angel Fish

Michael G. LaFosse

Low Intermediate

©2021 - USA

Duo paper is best. A standard 15 cm square of origami paper makes a 9.5 cm long model.

Inspired by John Cunliffe's "Twist Fish"

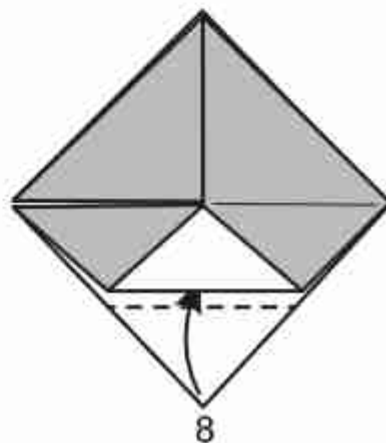
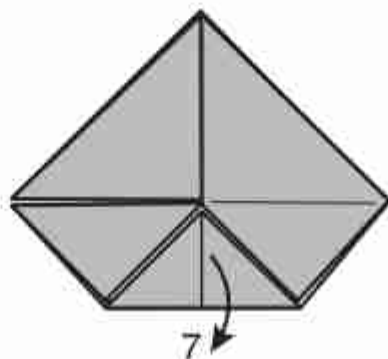
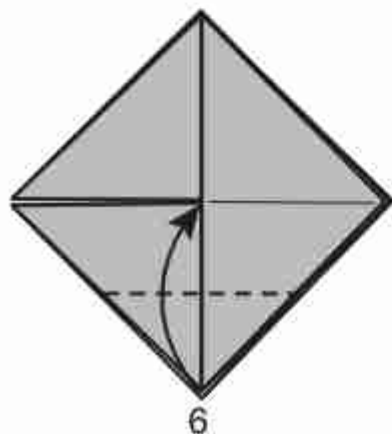
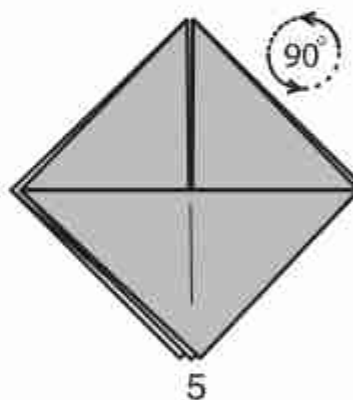
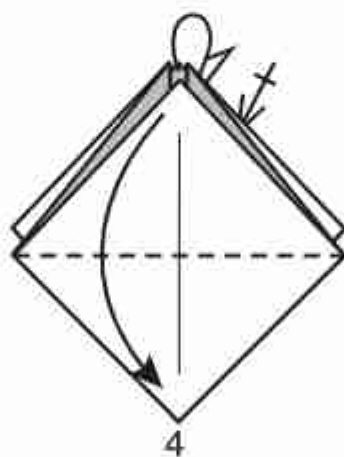
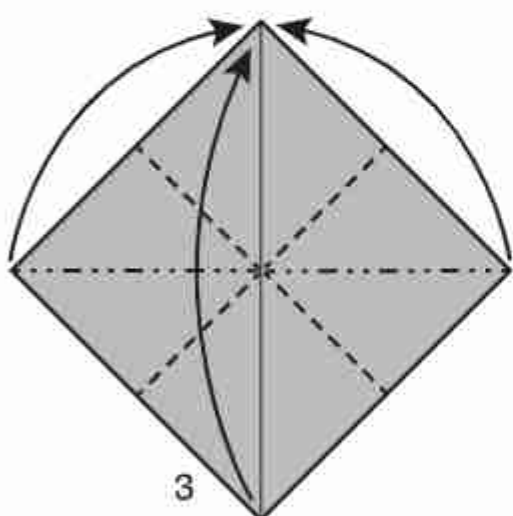
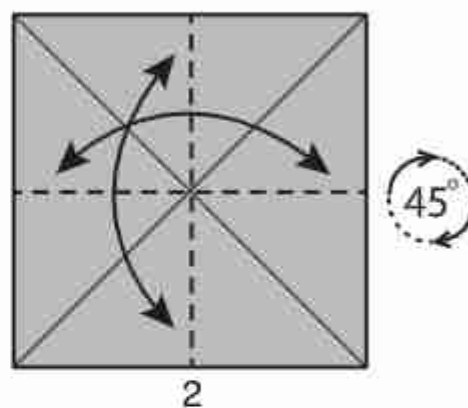
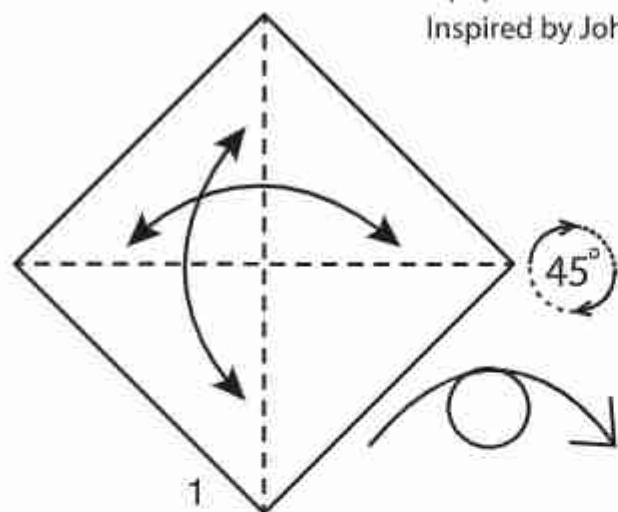

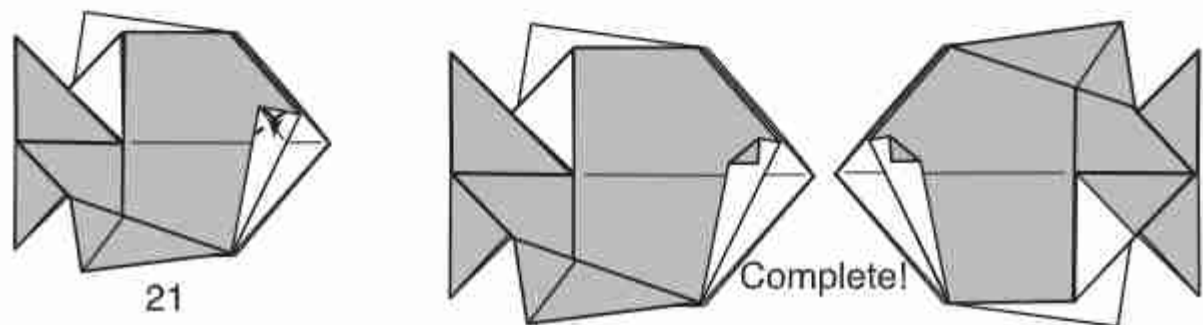
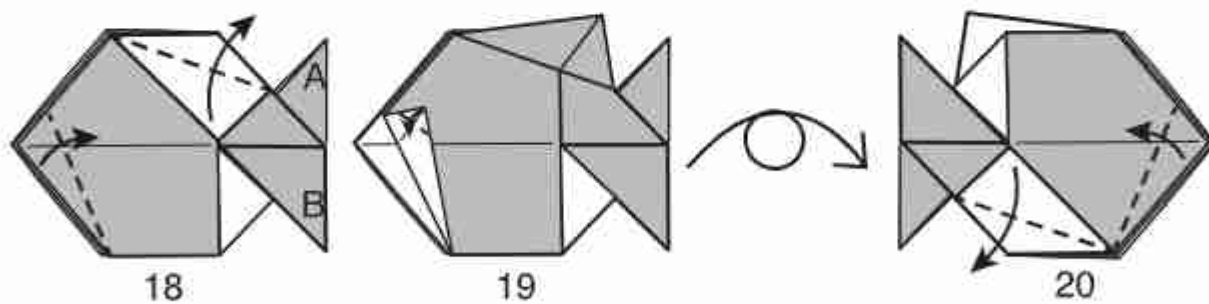
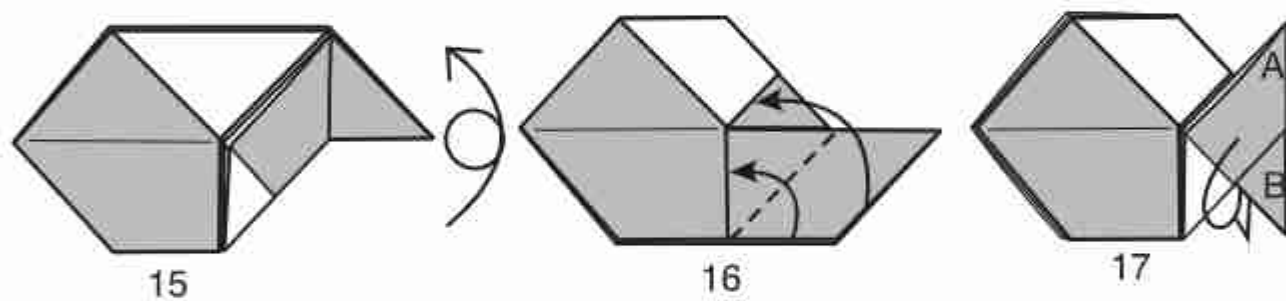
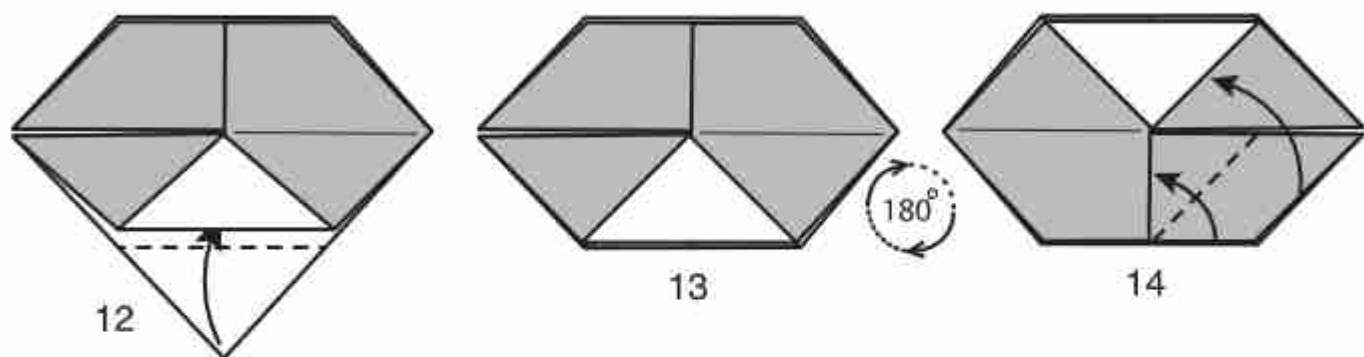
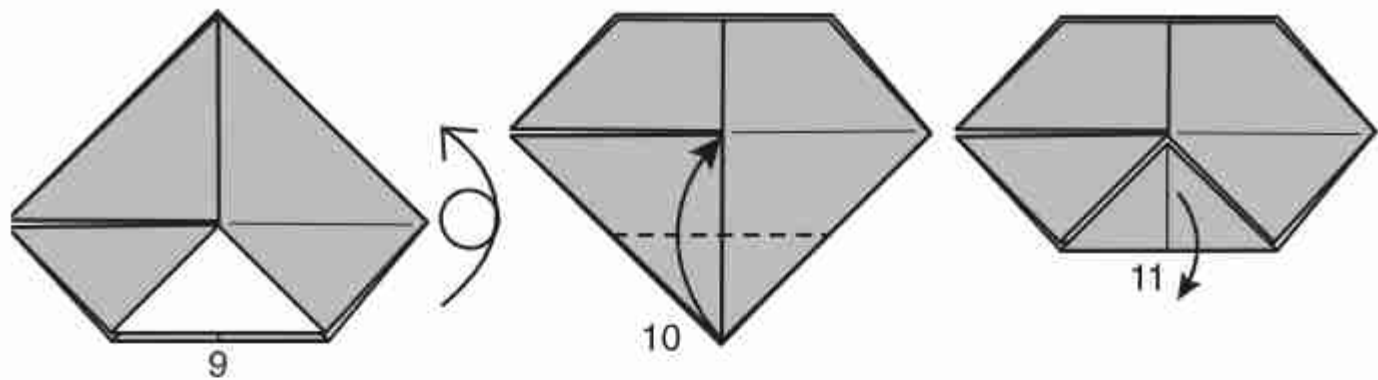

Completel

This model is ripe for experimentation beyond paper choice for size, color combinations, and patterns. Countless variations are possible. Below is a small sample of the dozens I have recorded to date.

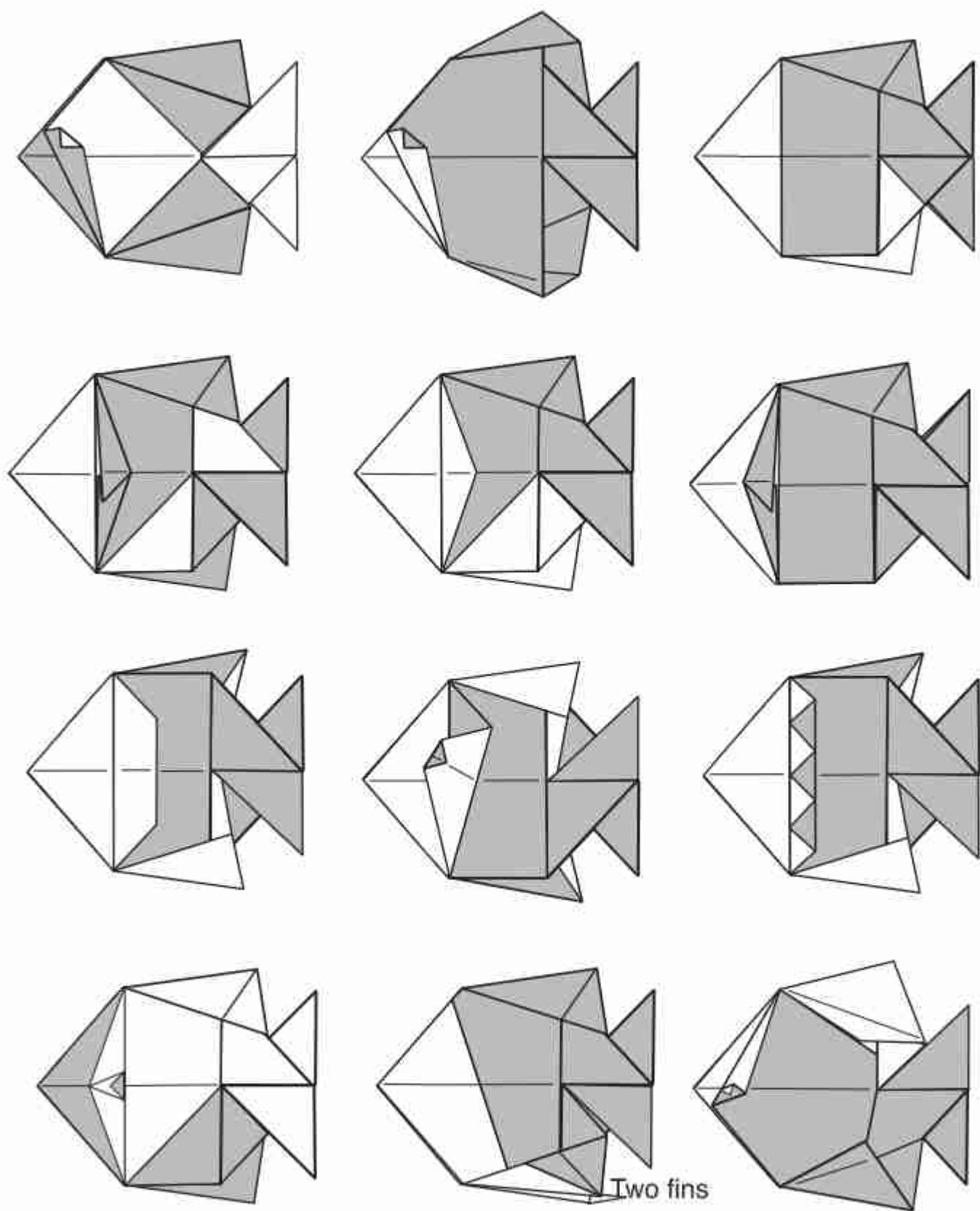

Two fins

A Butterfly for Ranana Benjamin

Michael G. LaFosse

©2020 - USA

Intermediate

A 15 cm square will produce a butterfly with a wingspan of approximately 11 cm.

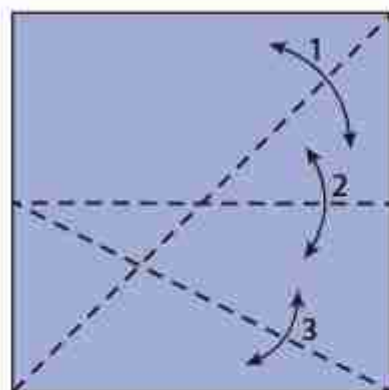

1

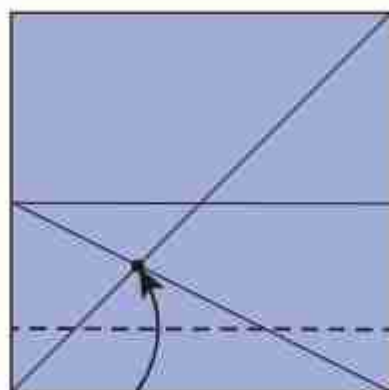

2

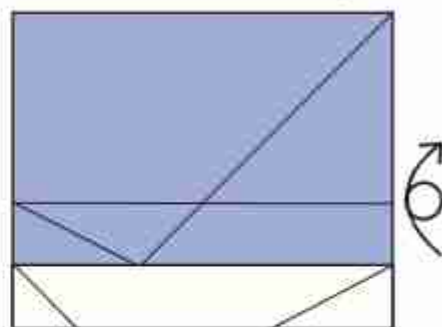

3

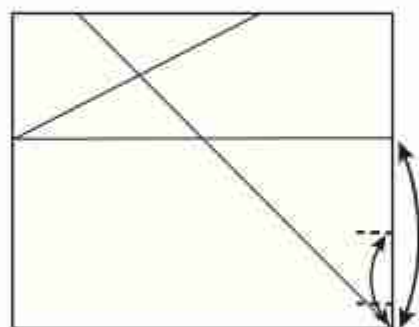

4

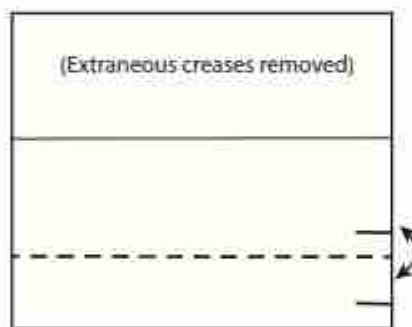

5

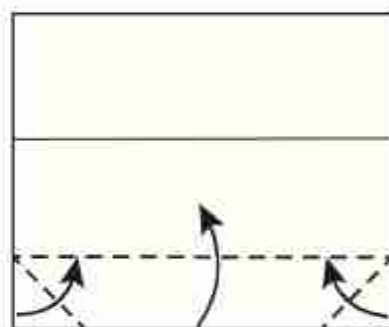

6

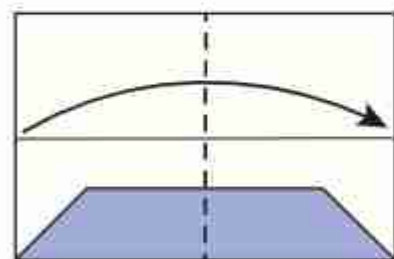

7

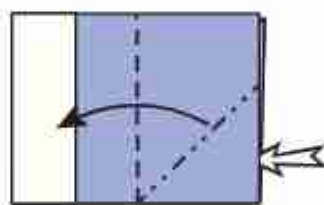

8

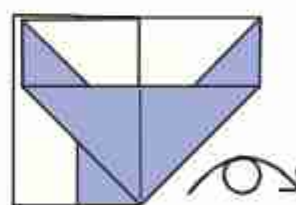

9

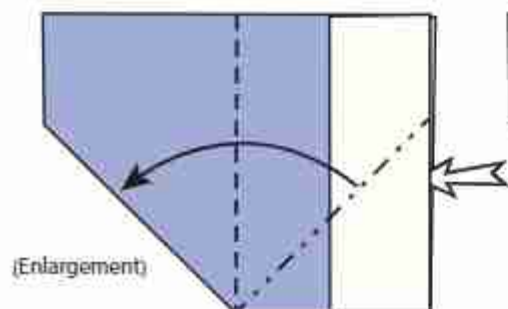

(Enlargement)

10

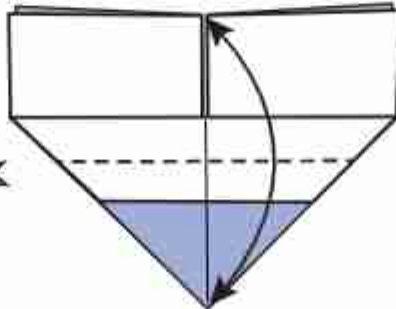

11

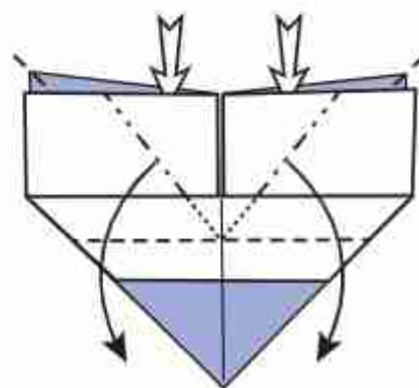

12

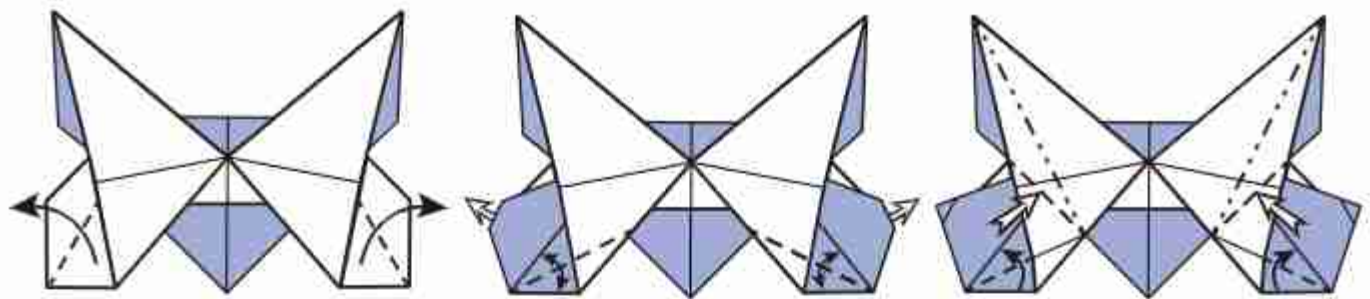

13

14

15

(Extraneous creases removed)

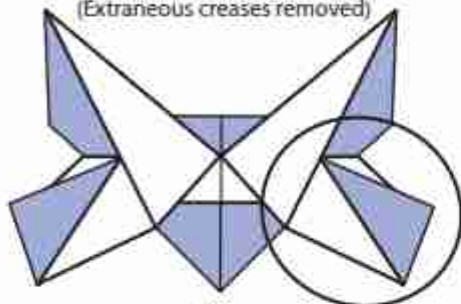

16

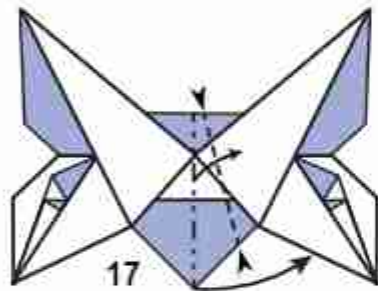
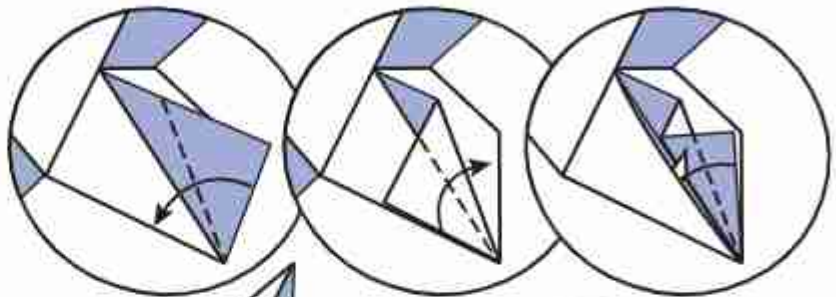

17

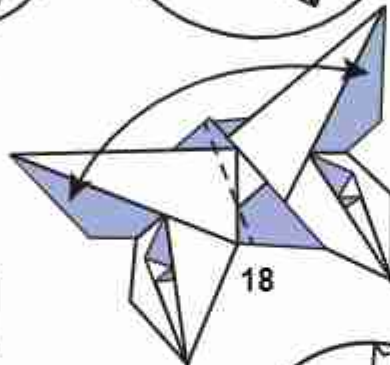

18

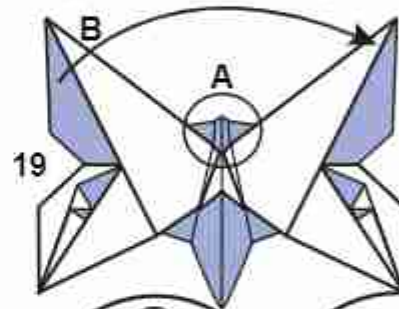

19

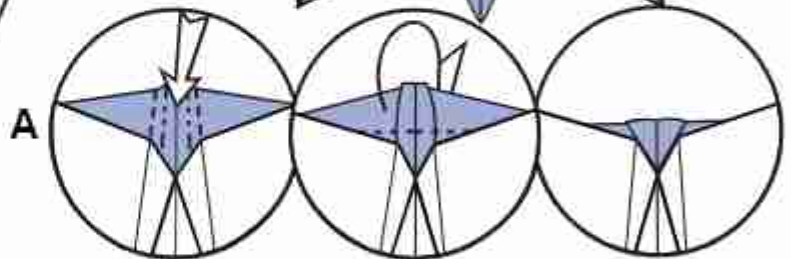

A

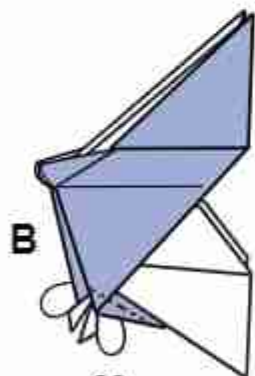

B

20

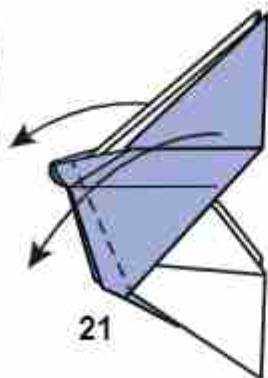

21

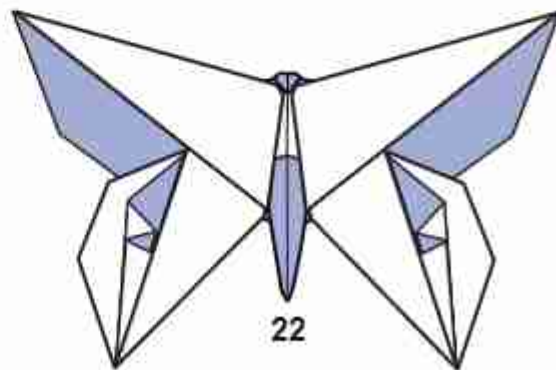

22

Ginkgo Leaf

Michael G. LaFosse

Low Intermediate

©2019 - USA

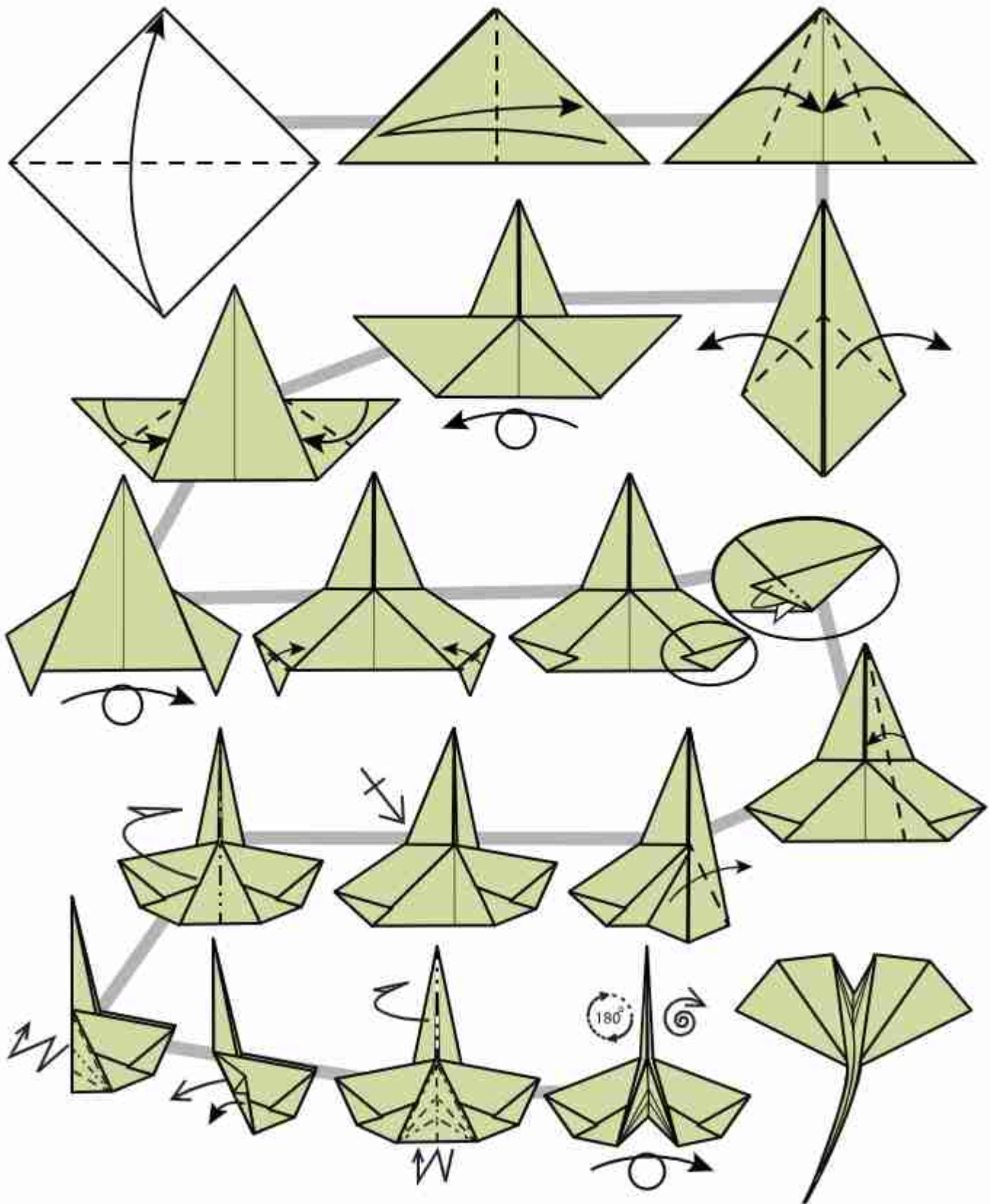

Penguin

Michael G. LaFosse

Low Intermediate

©2016 - USA

Duo paper is best. A standard 15 cm square of origami paper makes a 12 cm tall model.



1

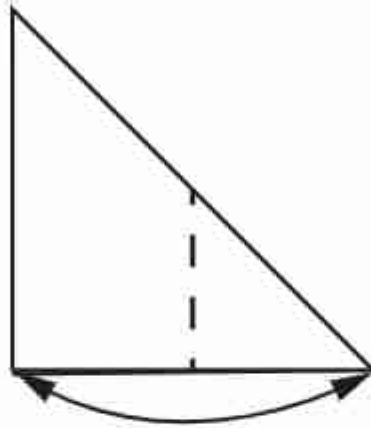

2

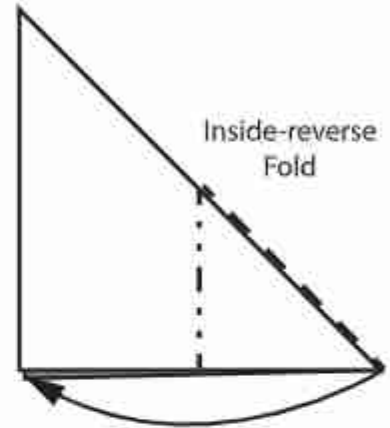

3

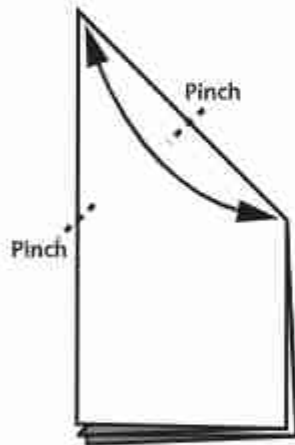

4



5

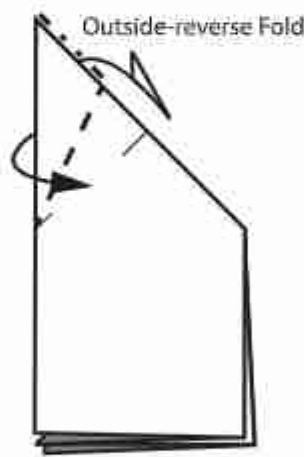

6

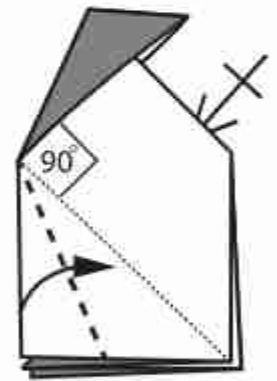

7

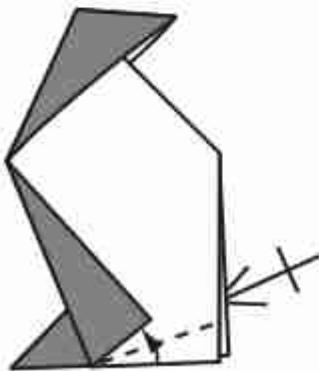

8

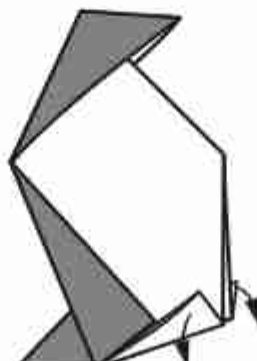

9

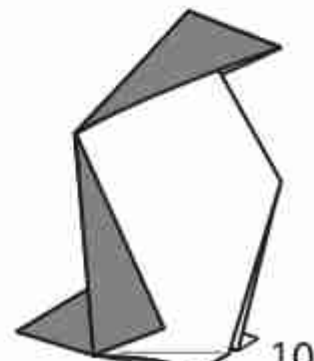

10

Samurai Helmet

Michael G. LaFosse

©2015 - USA

Intermediate

Ratio

10

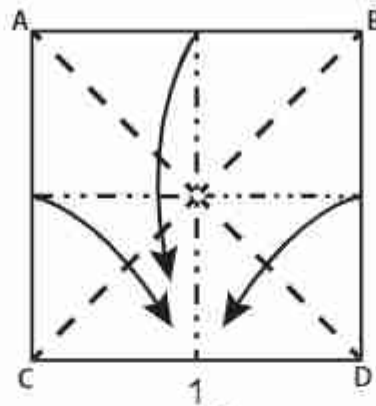

A highly-stylized helmet with many possibilities for variation.

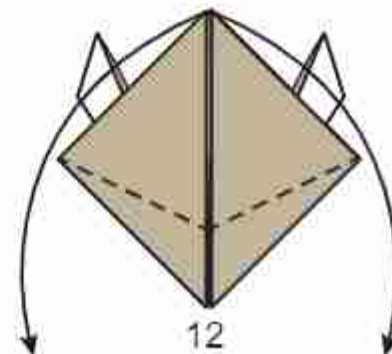
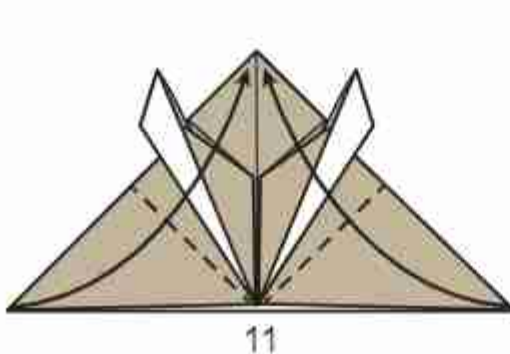
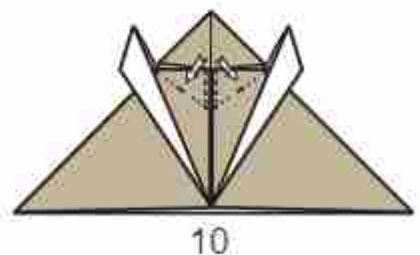
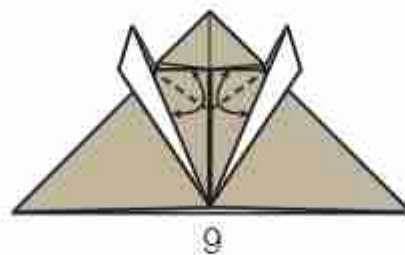
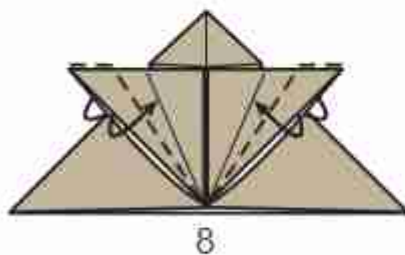
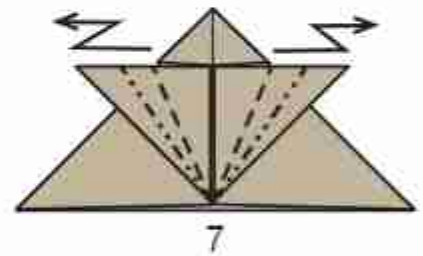
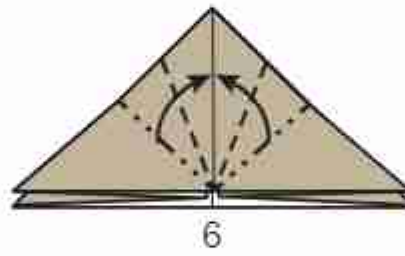
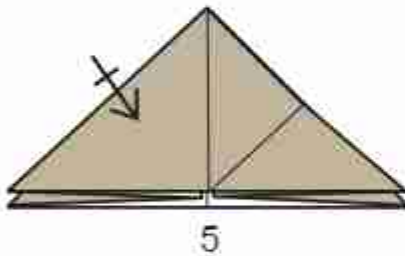
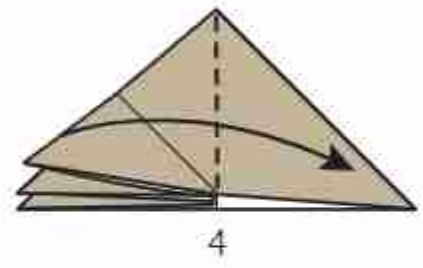
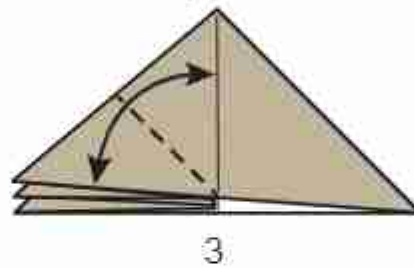
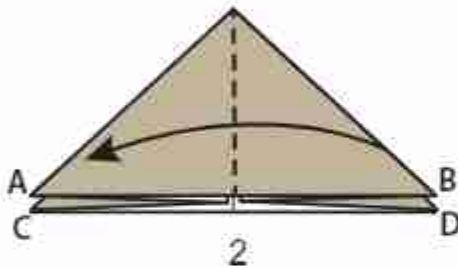

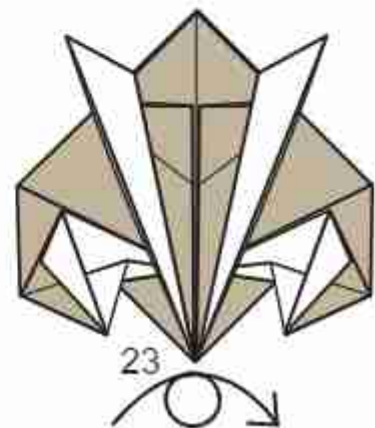
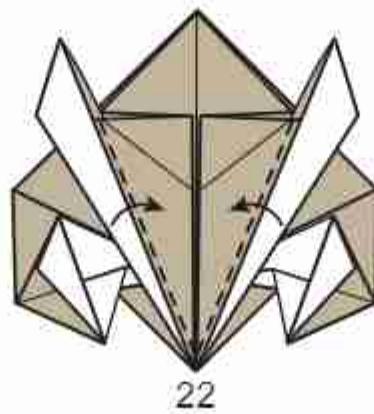
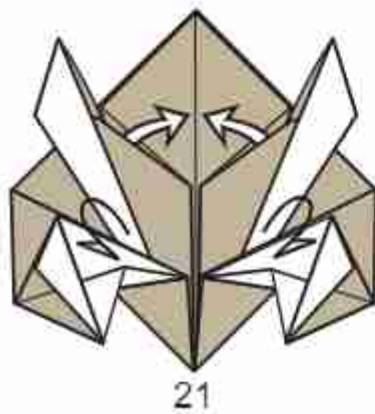
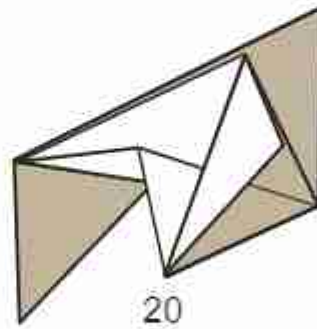
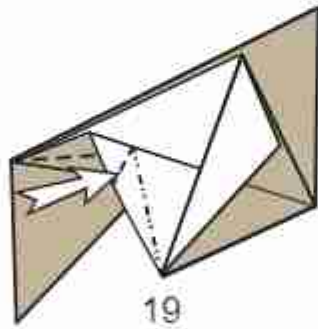
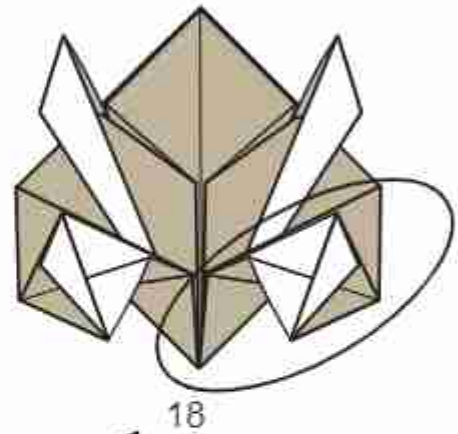
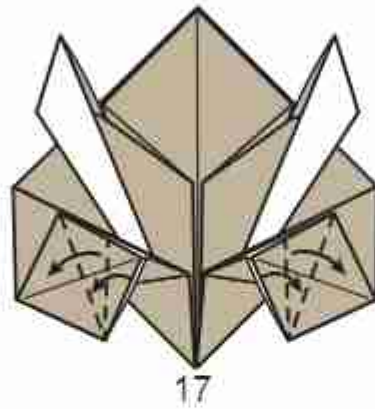
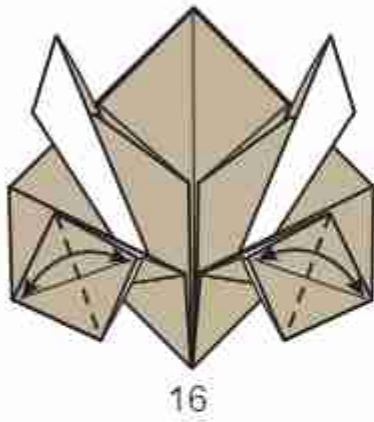
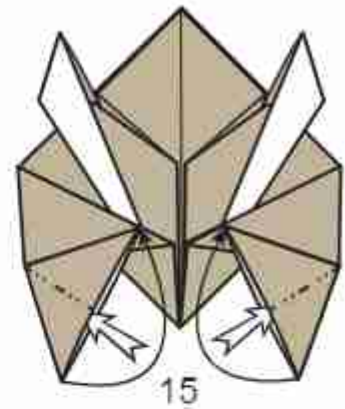
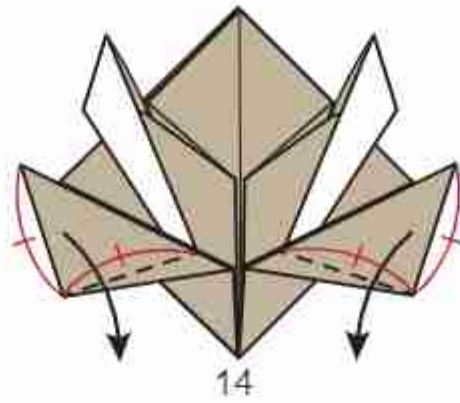
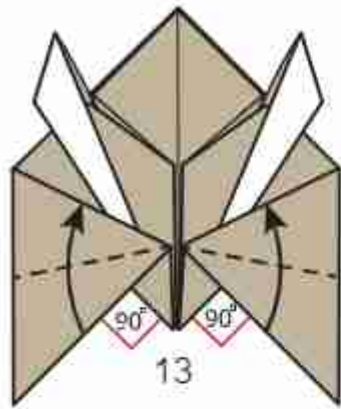

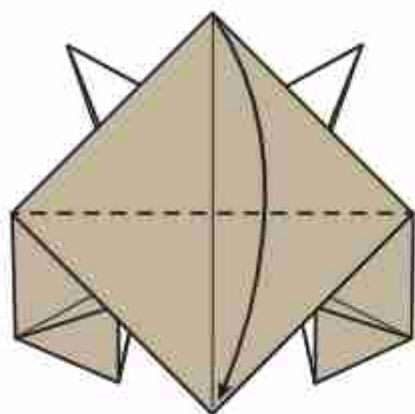

24

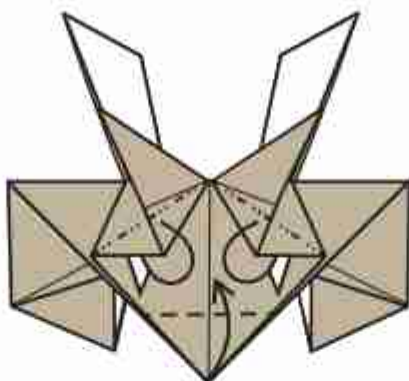

25

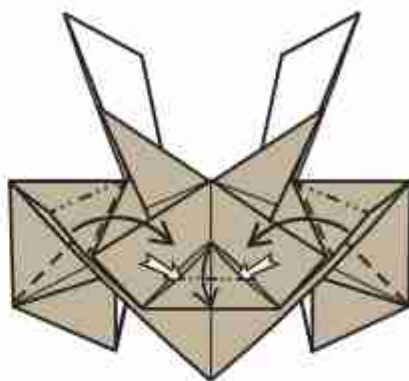

26

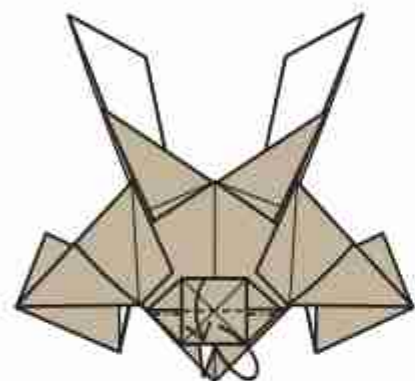

27

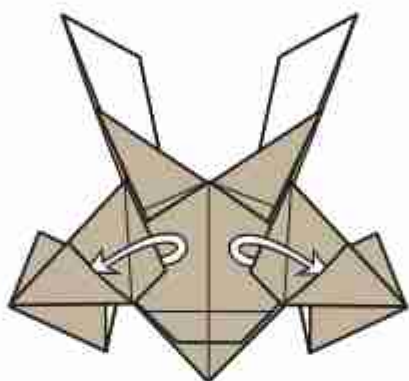

28

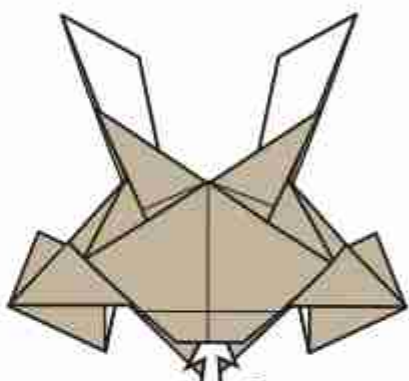

29

Open

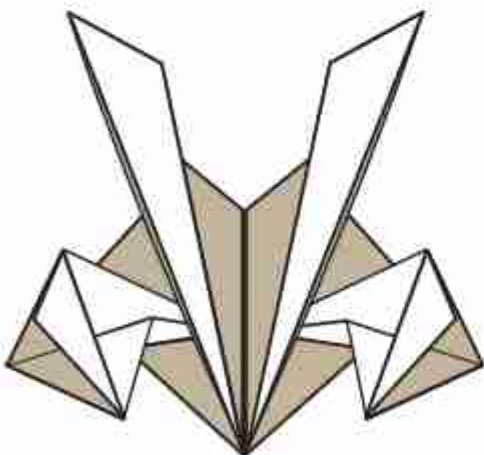

30



Just a few variations.

Cat

Intermediate

Qingquan Li

©2021 - China

01

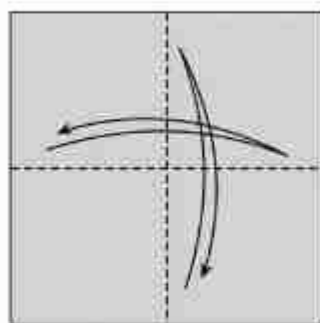

02

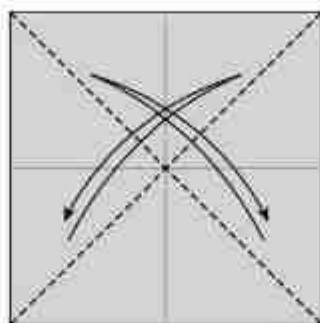

03

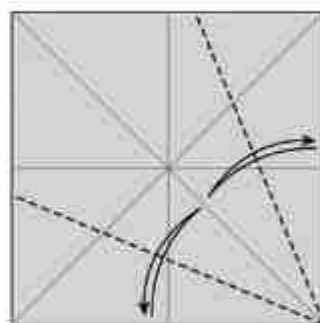

04

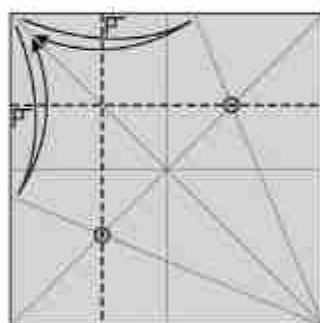

05

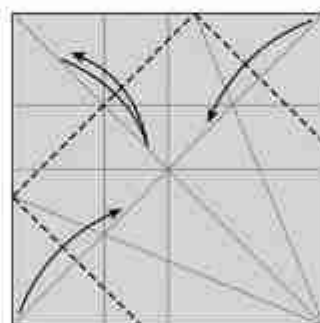

06

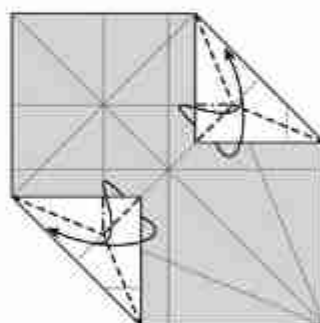

07

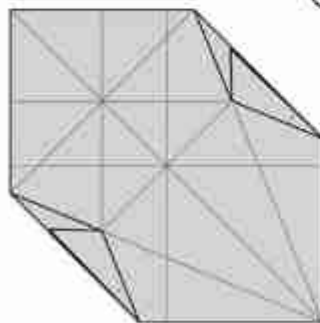

08

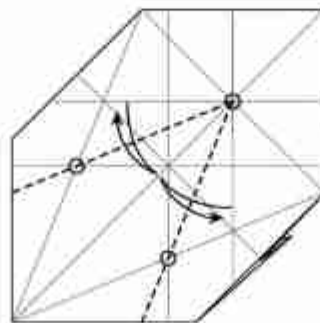

09

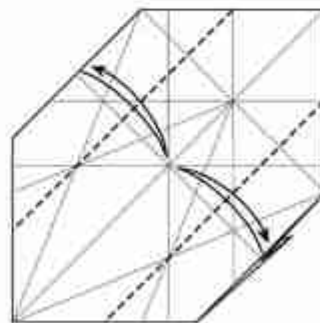

10

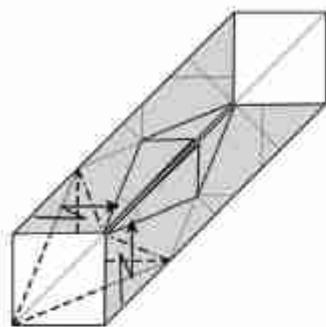

11

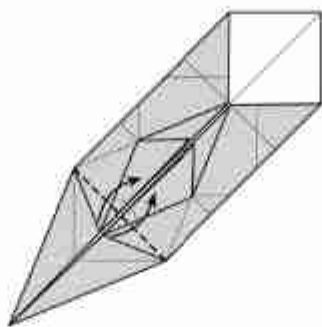

12

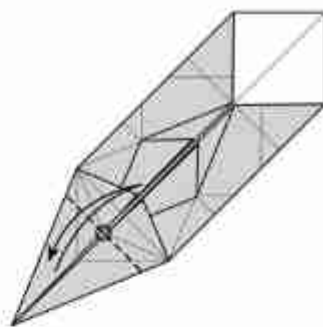

13

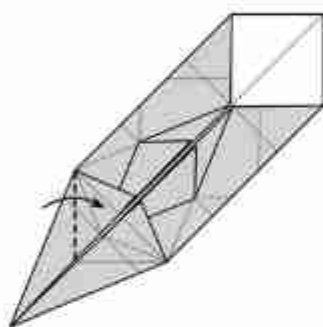

14

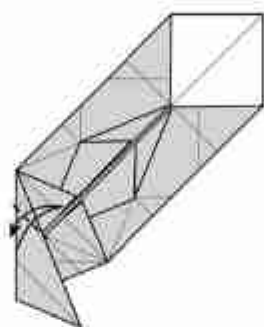

15

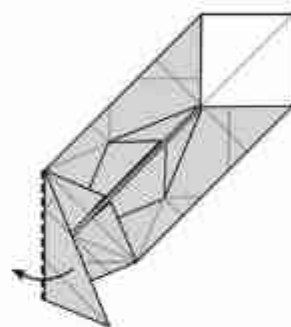

16

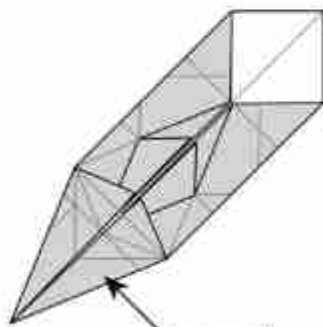

17

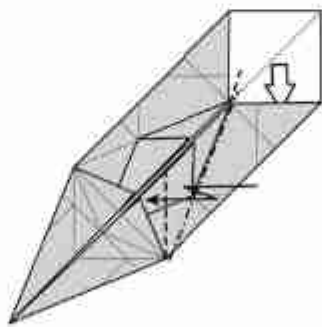

18

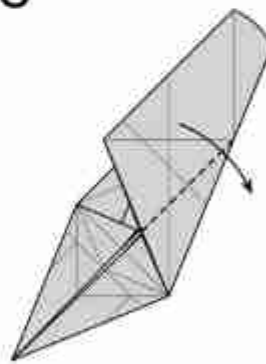

13-15

19

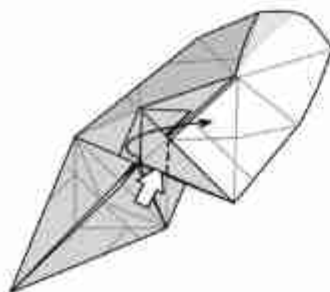

20

17-19

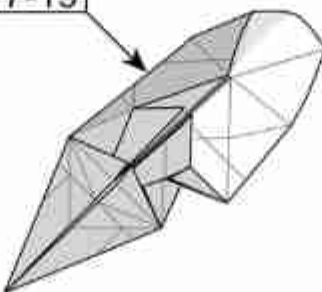

21

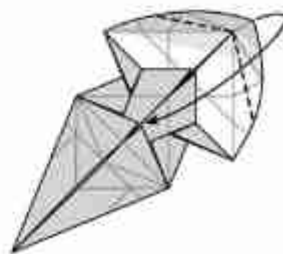

22

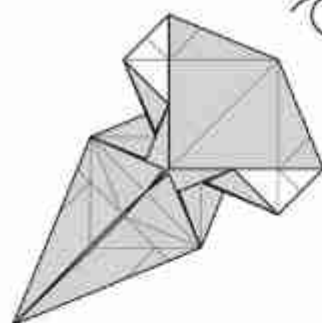

23

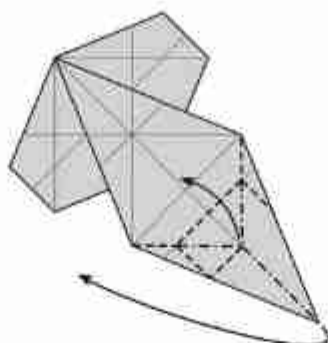

24

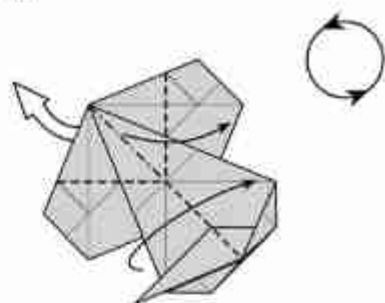

25

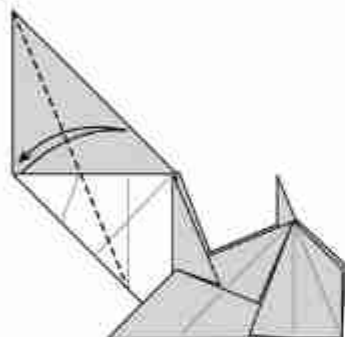

26

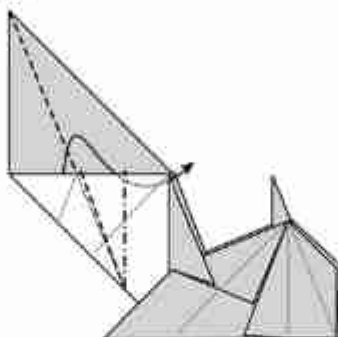

27

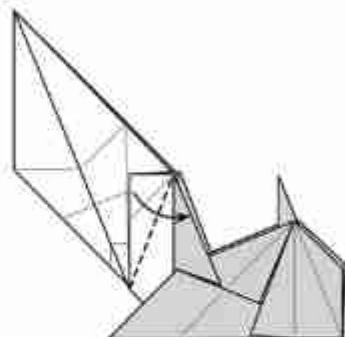

28

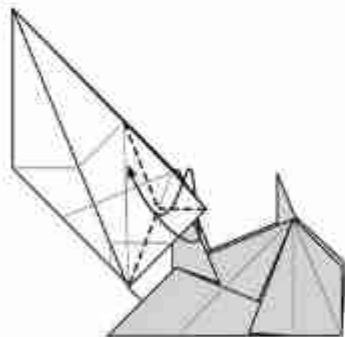

29

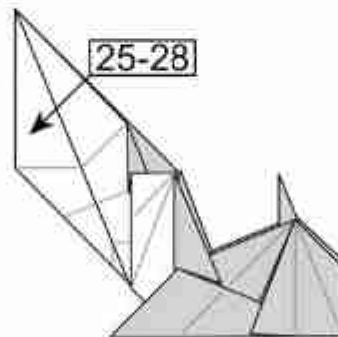

30

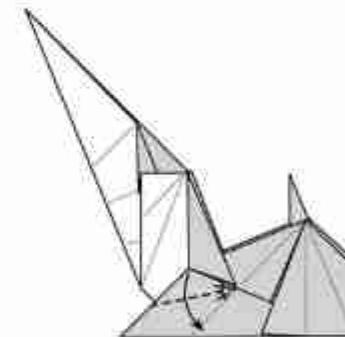

31

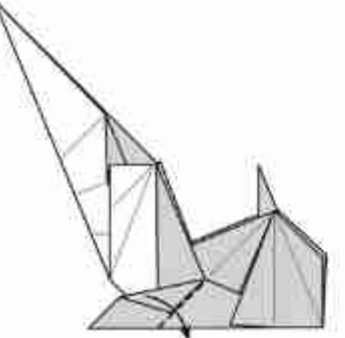

32

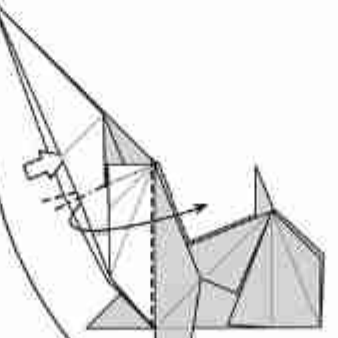

33

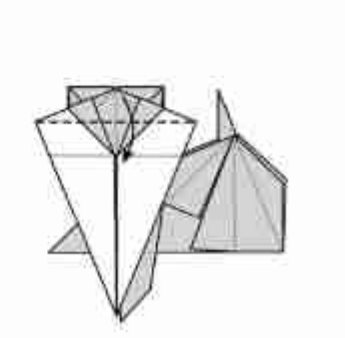

34

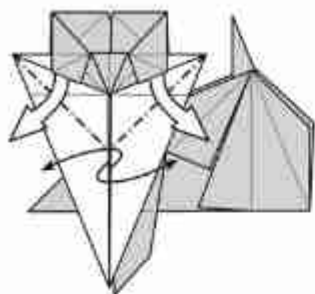

35

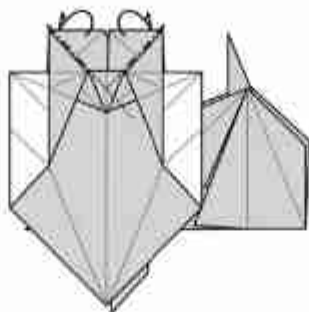

36

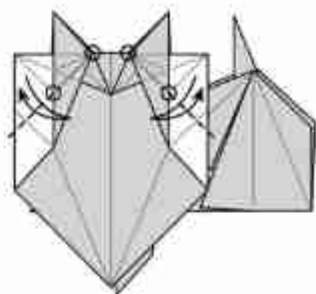

37

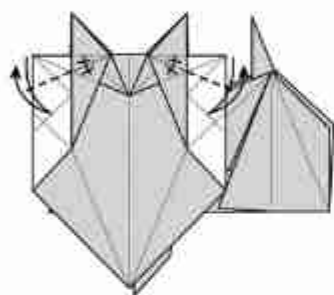

38

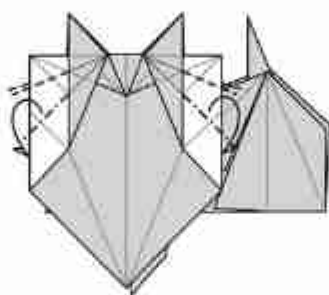

39

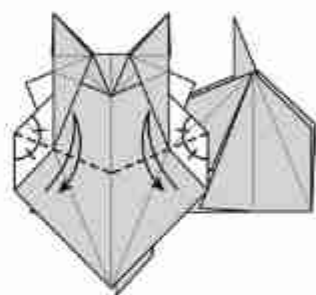

40

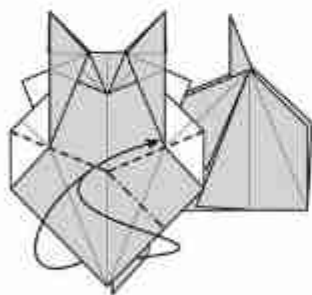

41

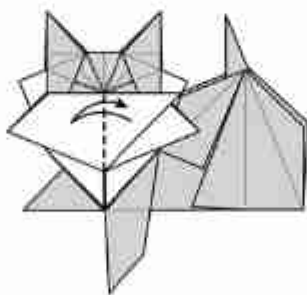

42

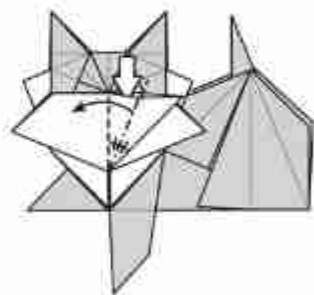

43

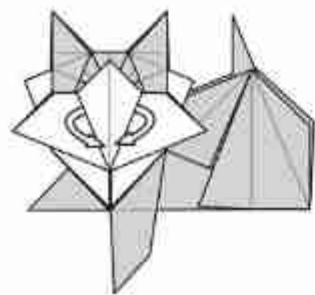

44

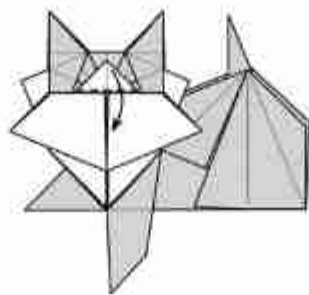

45

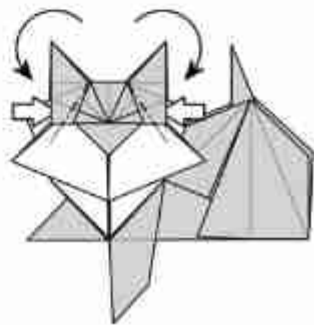

46

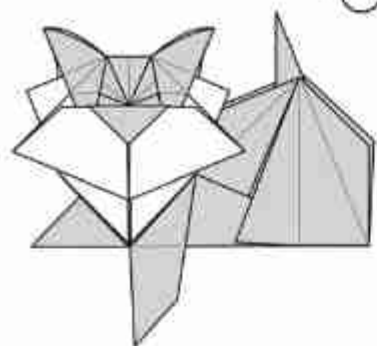

47

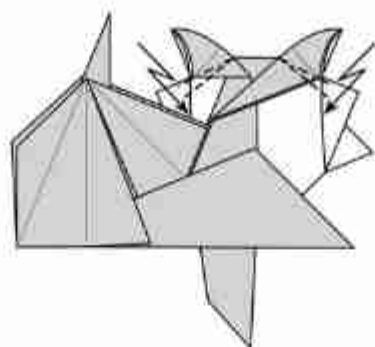

48

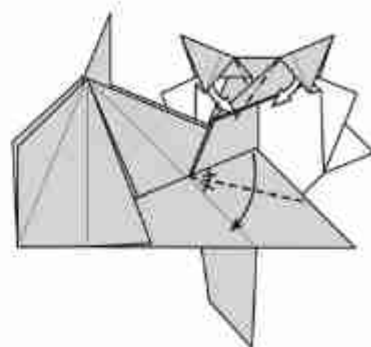

49

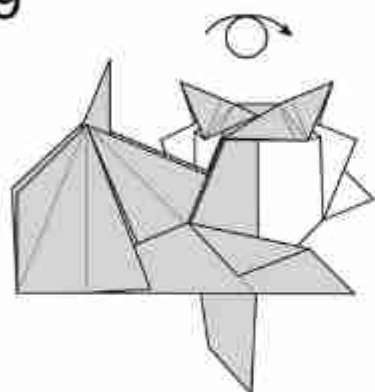

50

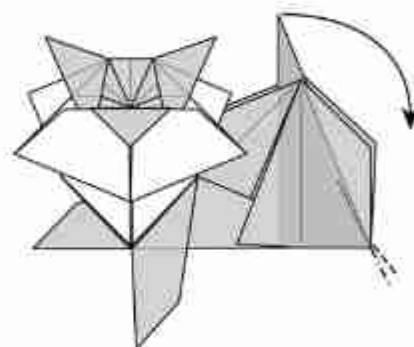

51

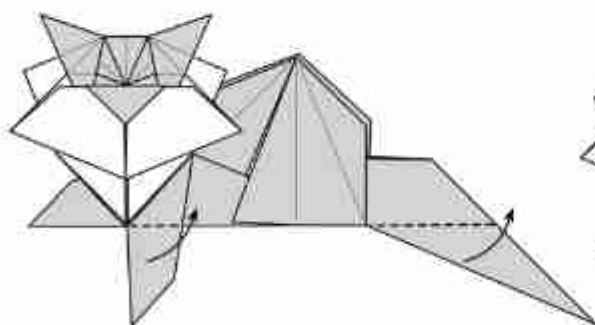

52

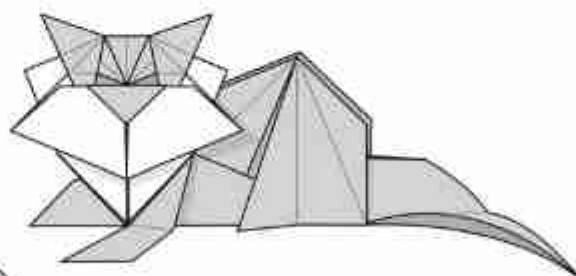

Sparrow

Intermediate

Qingquan Li

©2021 - China

01

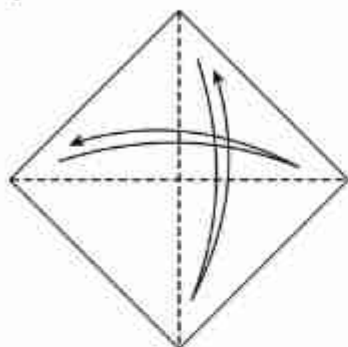

02

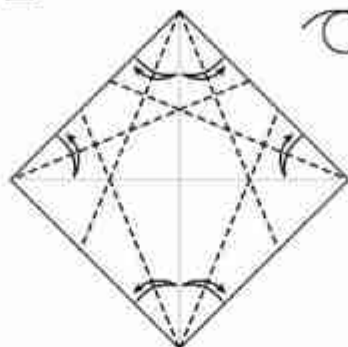

03

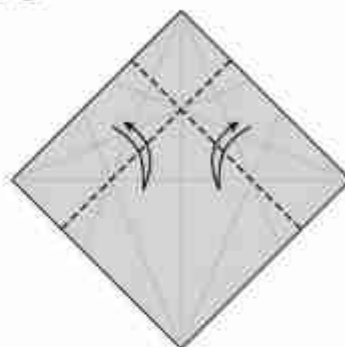

04

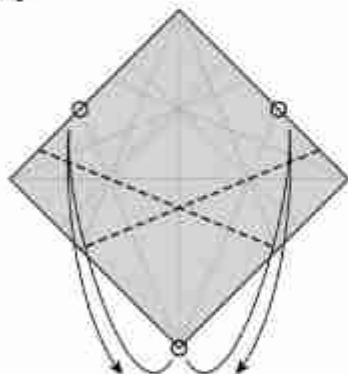

05

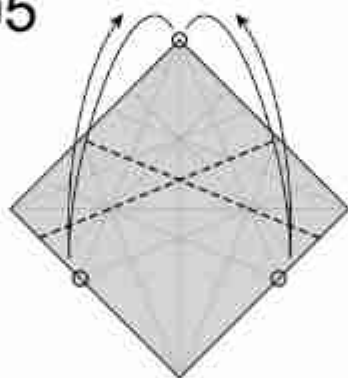

06

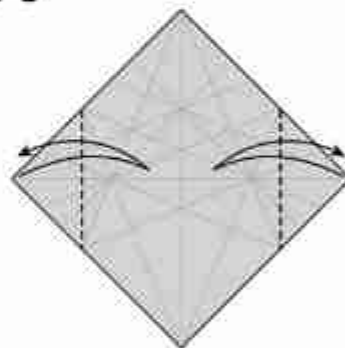

07

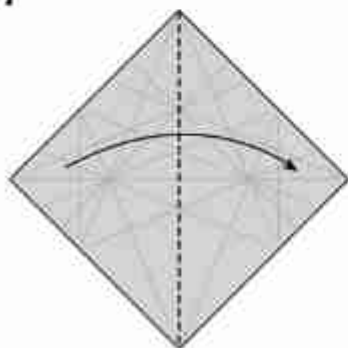

08

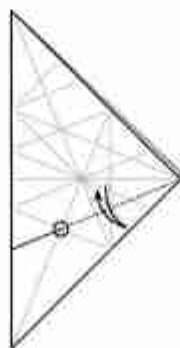

09

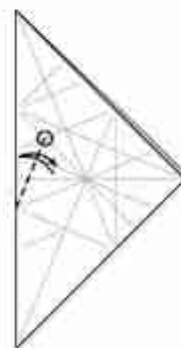

10

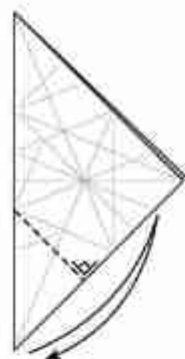

11

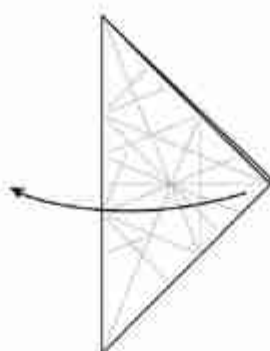

12

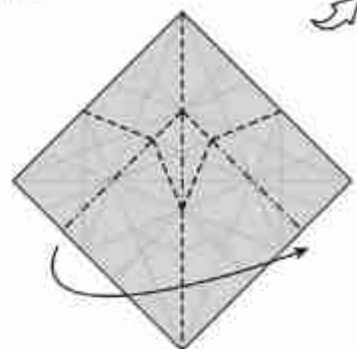

13

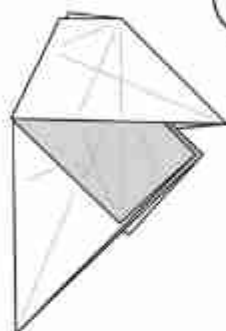

14

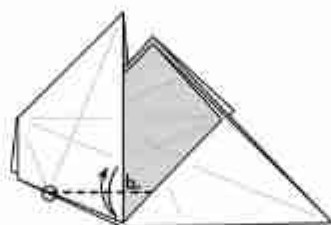

15

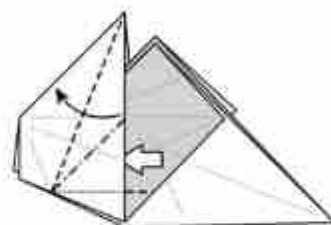

16

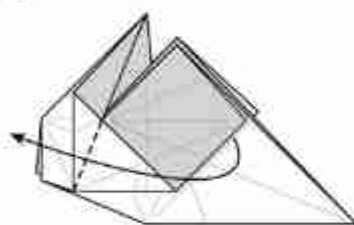

17

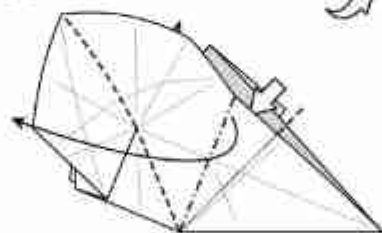

18

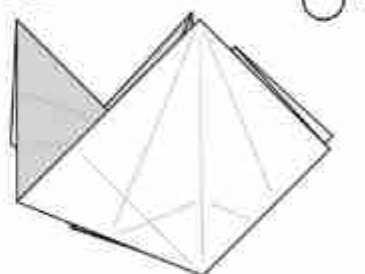

19

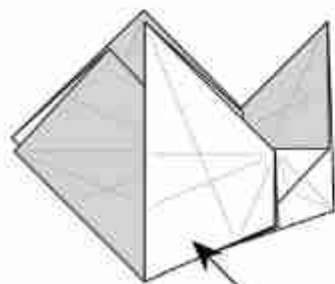

20

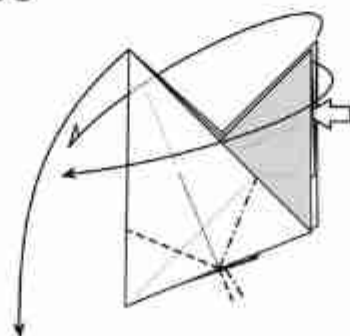

21

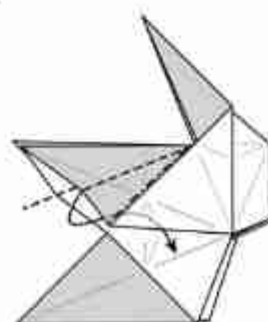

14-18

22

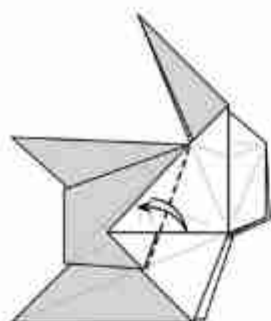

23

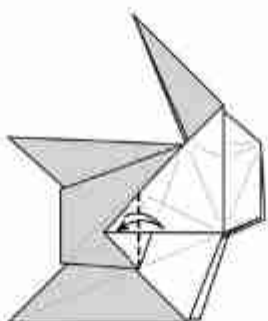

24

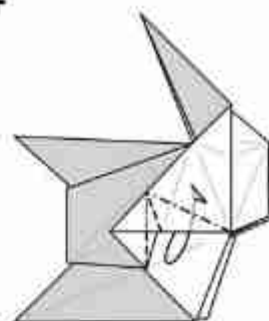

25

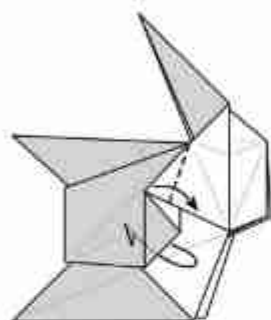

26

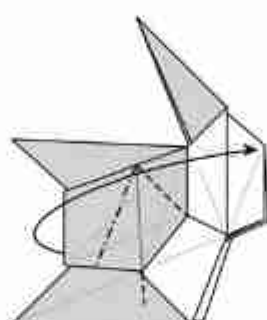

27

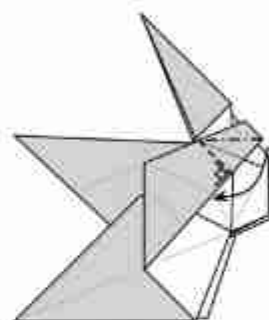

28

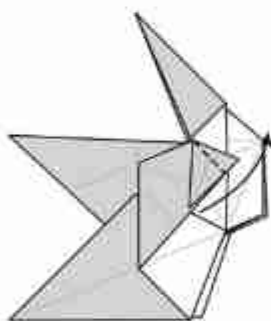

29

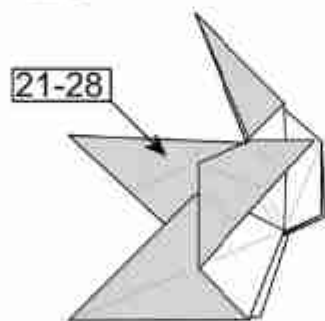

30

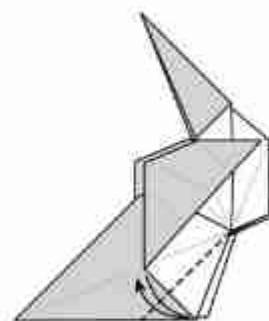

31

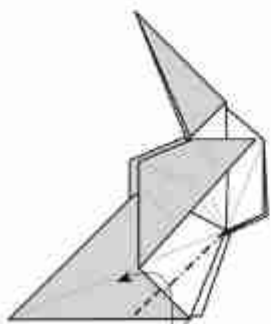

32

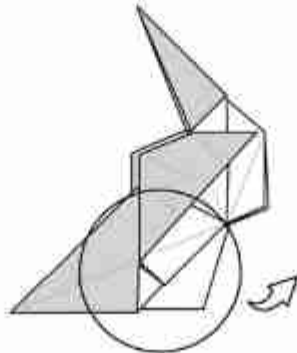

33

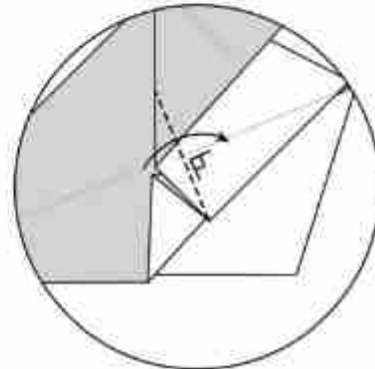

34

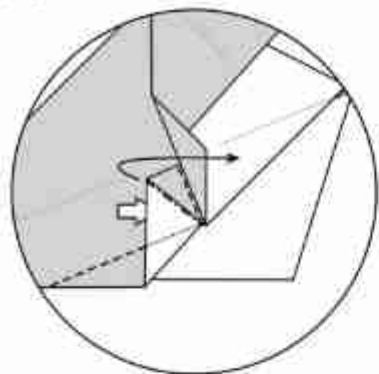

35

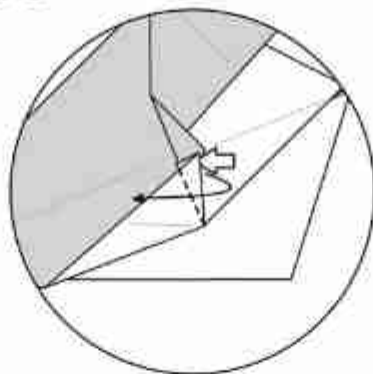

36

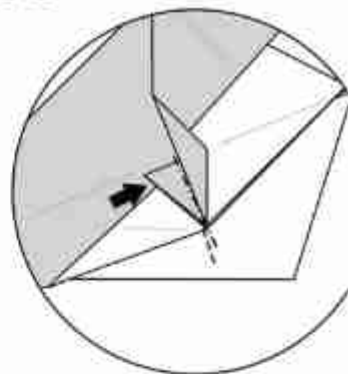

37

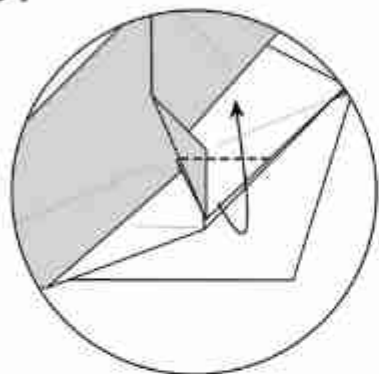

38

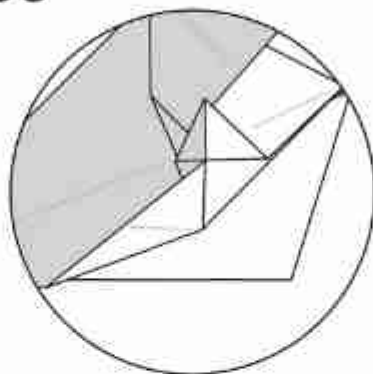

39

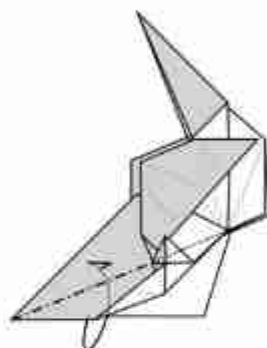

40

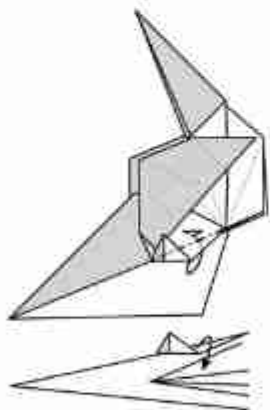

41

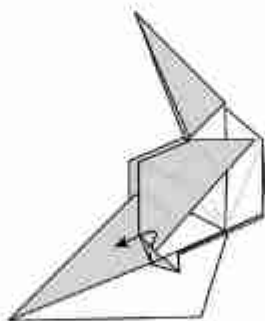

42

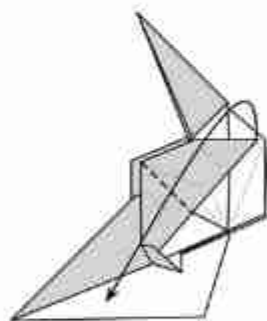

43

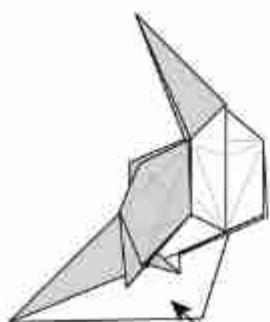

44

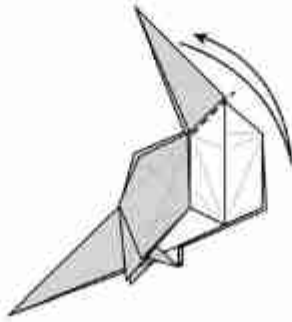

45

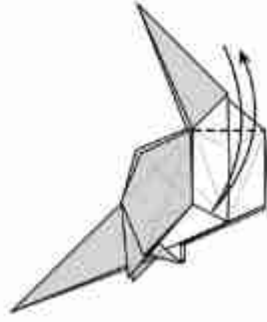

30-42

46

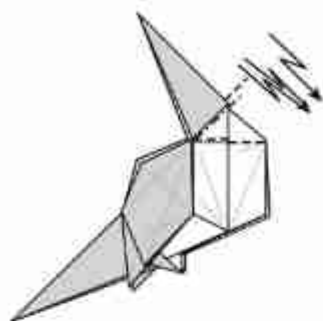

47

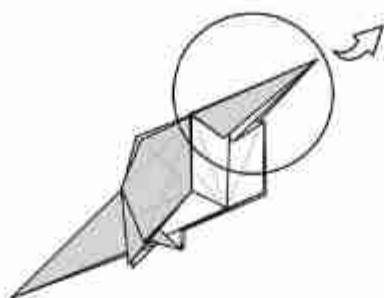

48



49

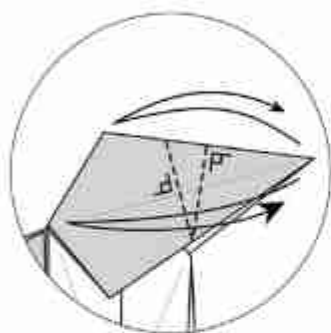

50

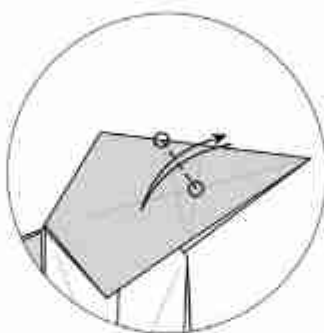

51

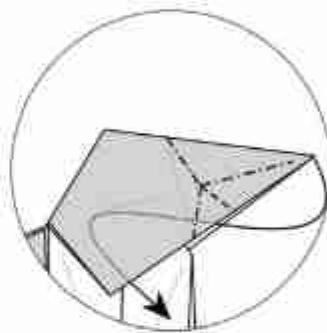

52

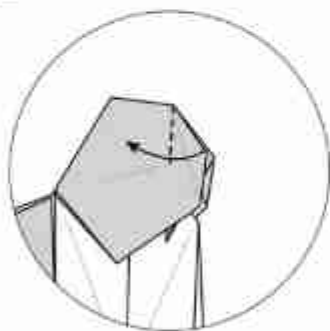

53

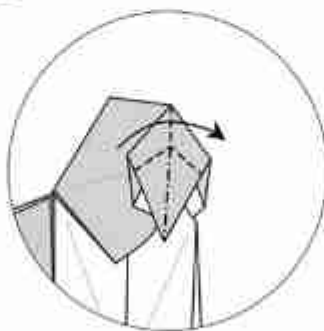

54

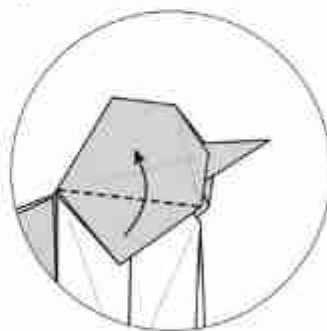

55

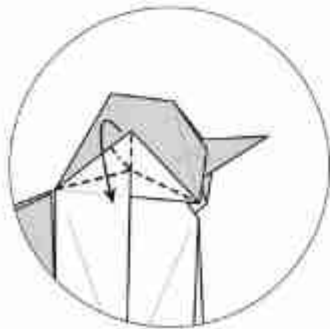

56

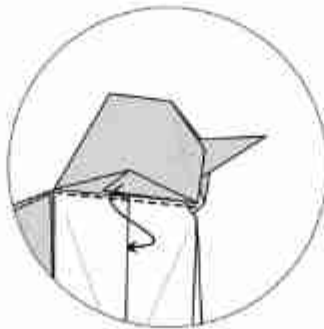

57

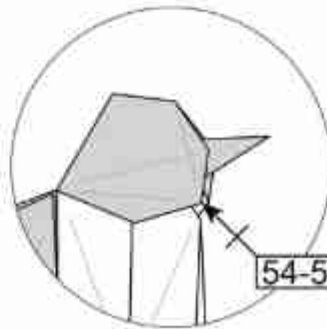

58

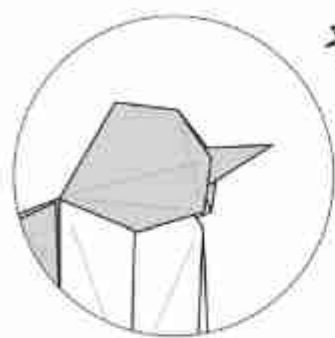

59

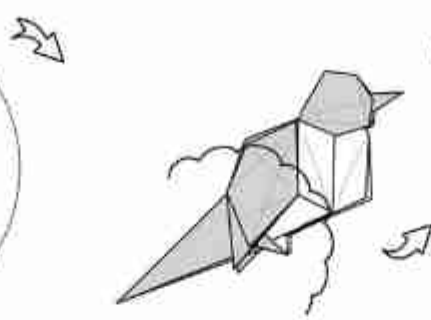

60

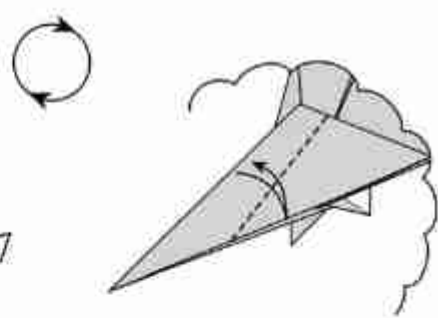

61

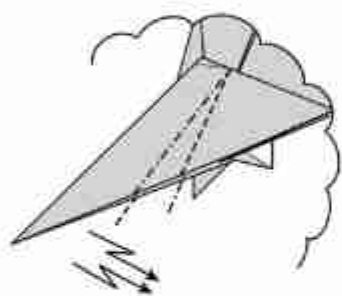

62



63

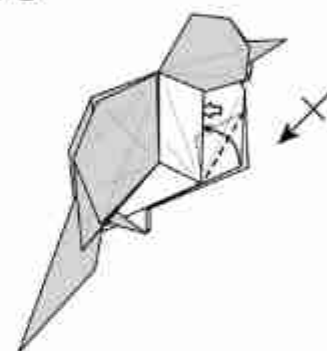

64

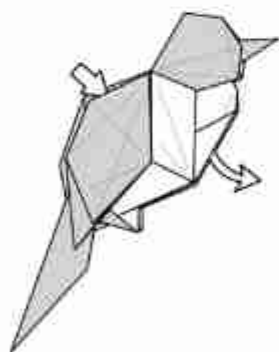

65

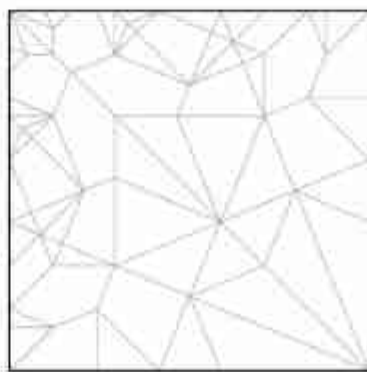
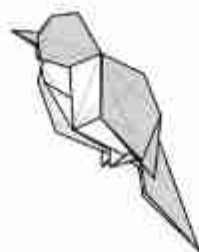
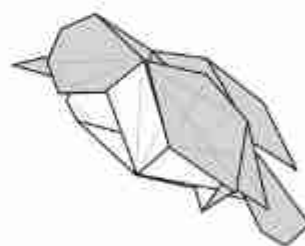
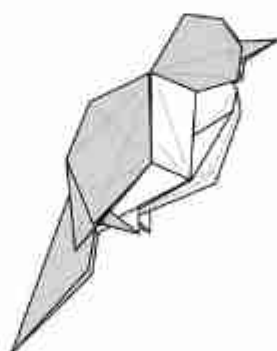

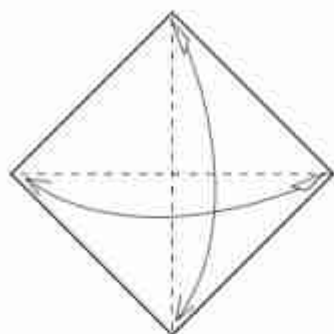

1. White side up.
Precrease diagonally.

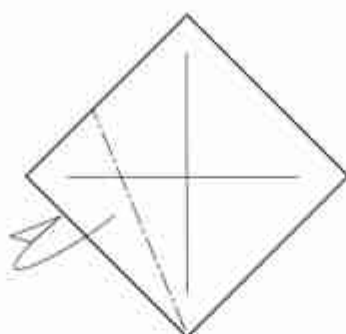

2. Mountain fold along
angle bisectors.

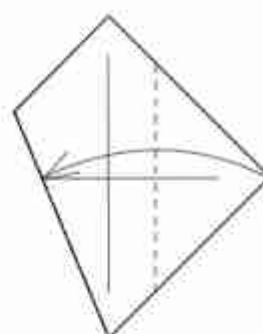

3. Valley.

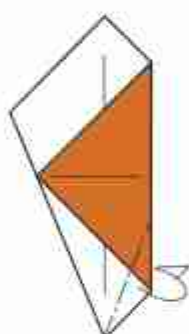

4. Mountain fold along
angle bisectors.



5. Valley.

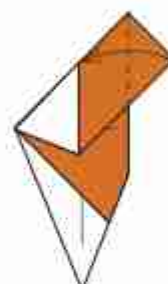

6. Valley.



7. Unfold back.

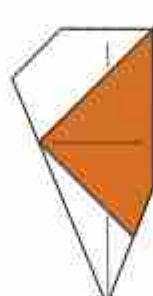

8. Turn over.

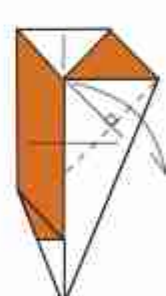

9. Valley down. Note the
connecting point on top.

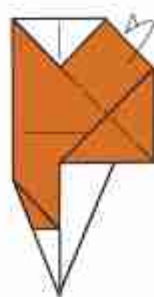

10. Mountain fold behind.

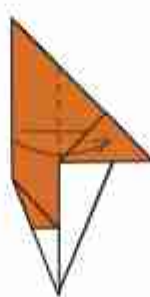

11. Valley.

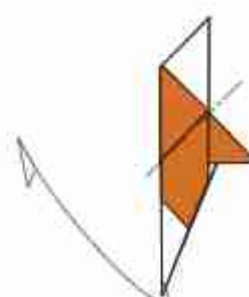

12. Mountain fold the 2 sets of
points behind.

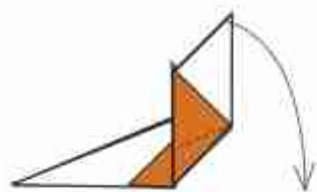

13. Swing back the large flap.

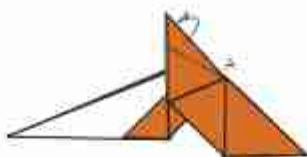

14. Mountain behind. Observe how the fold starts from point A.



15. Mountain the thickness behind along angle bisectors.

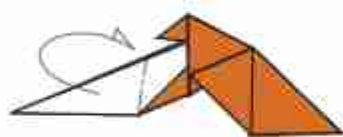

16. Mountain fold behind. Observe where the fold starts.

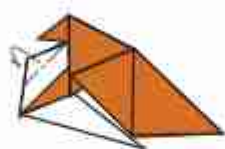

17. Mountain behind.

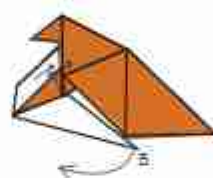

18. Pleat into position. Observe in the next drawing, how point B pivots.



19. Slot the folded excess underneath the shaded pocket.



20. Mountain fold.



21. Mountain behind. (Arbitrary fold)



22. Rotate to match the orientation in the next drawing.

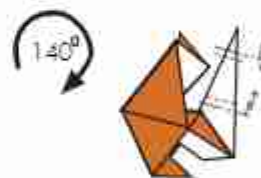

23. Pleat the guitar.



24. Mountain fold behind. Note: this is a slightly thick layer.

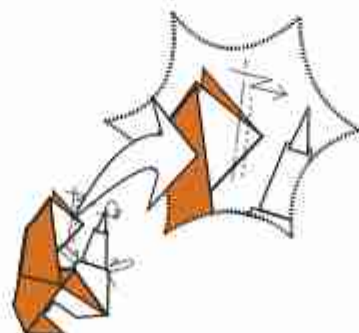

25. Round the tips of the guitar. Pleat the face to form the nose.



26. Completed Pureland Guitarist. Bang on a tunell!

Pureland Sailboat

Gareth Louis

©2020 - Australia

Simple

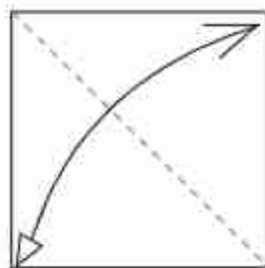

1. White side up. Lightly precrease diagonally.

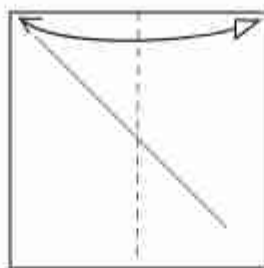

2. Precrease.

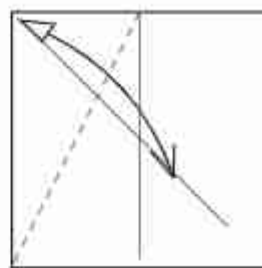

3. Precrease connecting the corner and the halfway point.

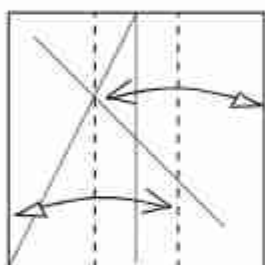

4. Valley to intersecting creases.

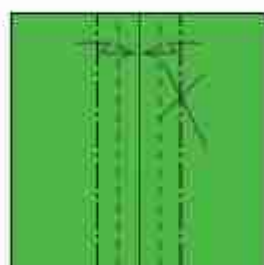

5. Pleat to the centre.

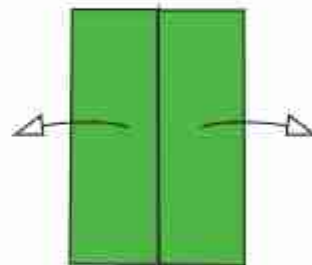

6. Undo the pleat.

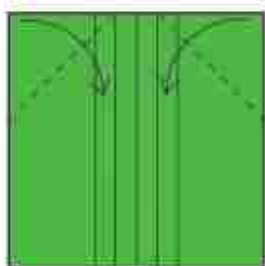

7. Valley to the creases made by the pleat.

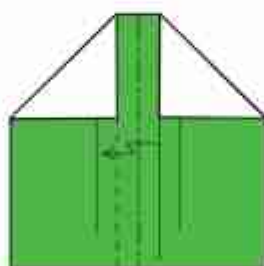

8. Pleat using all the existing creases.

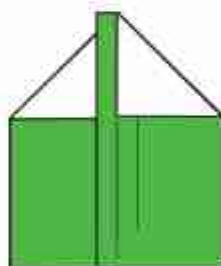

9. Turn over.

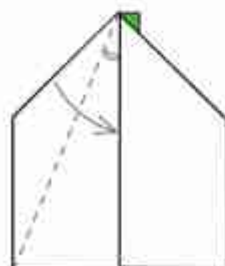
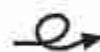

10. Valley along angle bisectors. This fold also connects with the corner below.

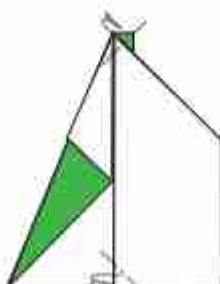

11. Mountain folds to lock the pleat in place.

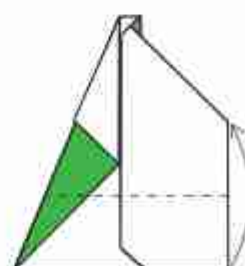

12. Valley to the indicated corner. (The fold also hits the corner of the white triangle on the left)

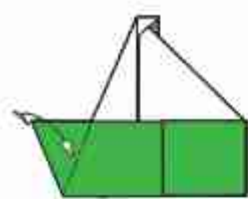

13. Mountain fold and unfold alligning with the edges beneath.

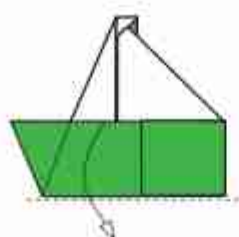

14. Unfold the flap back.

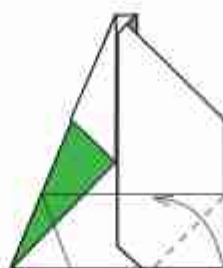

15. Valley to the created crease.

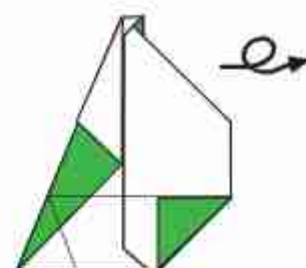

16. Turn over.

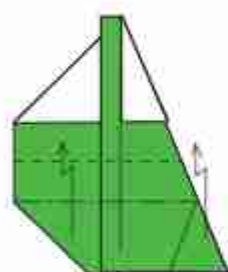

17. Pleat using the step 14 crease. This will hit the borders of the white triangles.

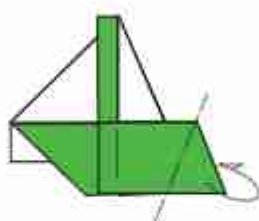

18. Mountain beneath using existing creases.

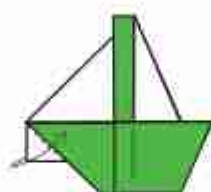

19. Valley the white corner inside.

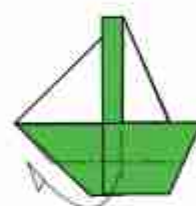

20. With reference to borders beneath, mountain 90° beneath. This forms the stand.

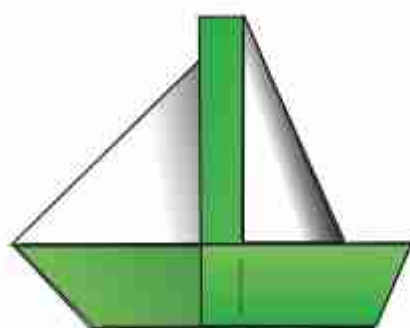

21. Completed Pureland Sailboat. Yes! It does stand!

Toucan

Intermediate

Gareth Louis

©2022 - Australia

Start with a 15cm square of black/yellow duo coloured kami.

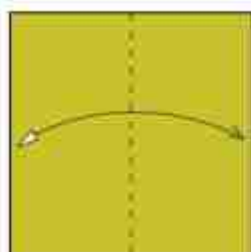

1. White side up.
Precrease

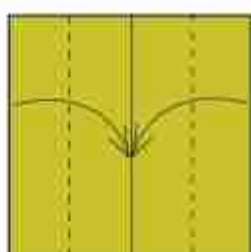

2. Valley to the centre.

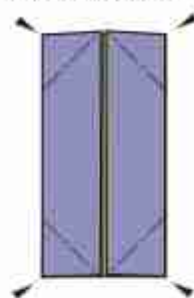

3. Precrease and reverse
on all corners.

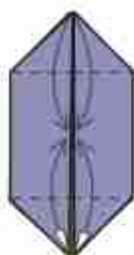

4. Valley fold the top
flaps down and
precrease flaps below.



5. Valley back
while inserting
reverse folds.

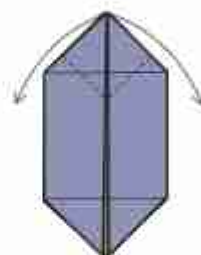

6. Valley down as
far as the folds
limit.

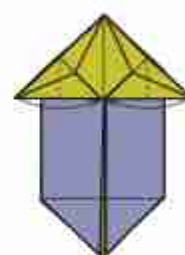

7. Valley flaps to the
centre.

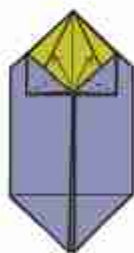

8. Valley flaps. The start
from the corner and
will hit the border.



9. Unfold back.



10. Valley flaps.



11. Reverse fold
the patterned
sections.



12. Redo the flaps
following the step 8
creases.

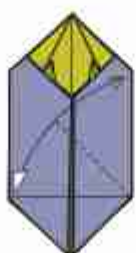

13. Very lightly
precrease. The
crease does not
go through the
end.

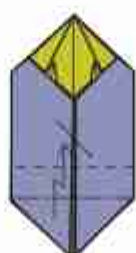

14. Pleat to the mark
created from the
previous step.

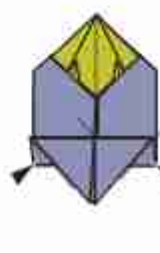

15. Reverse corners.

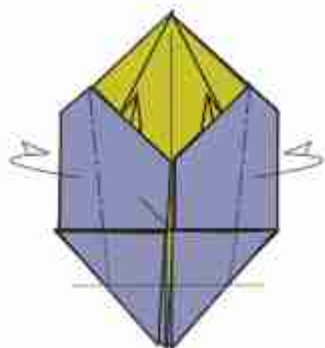

16. Mountain fold behind. Note where the crease starts and ends (at the hidden corner).

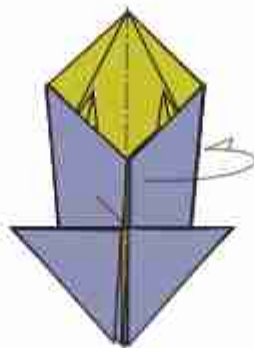

17. Mountain in half.

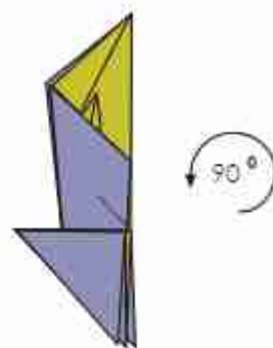

18. Rotate 90° anti-clockwise.

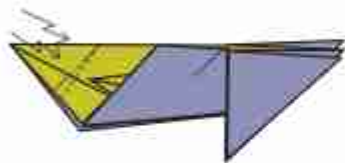

19. Crimp down.

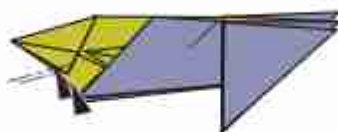

20. Reverse fold the protruding corners on both sides.

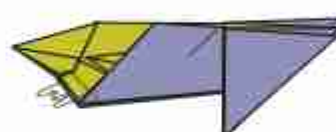

21. Mountain fold on both sides.

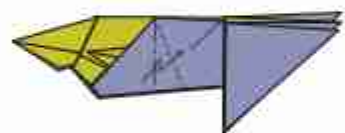

22. Pleat all layers.

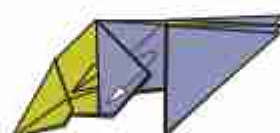

23. Crease firmly and undo the pleat.

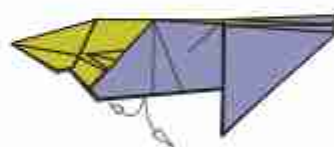

24. Open back the flaps from step 16 on both sides. Model will not lie flat.

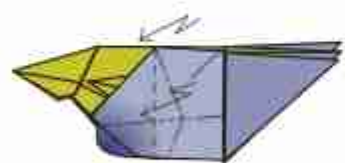

25. Make a 3D crimp on both sides. You can undo the step 21 folds and refold back if its easier.

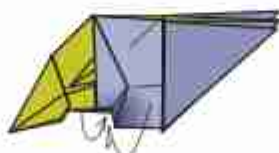

26. Mountain fold both sides to lock the crimp and flatten the model.

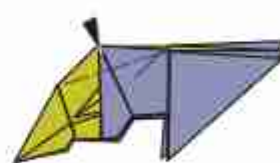

27. Sink according to where the fold starts and ends.

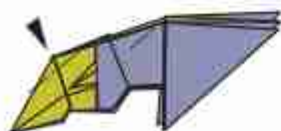

28. Sink again.

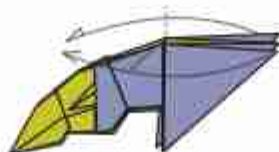

29. Swing both flaps.

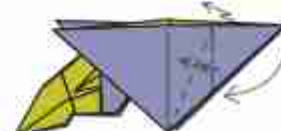

30. Crimp noting where the crease starts and ends.

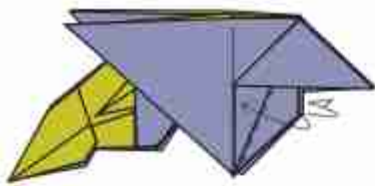

31. Valley flaps on both sides slotting into the pocket.

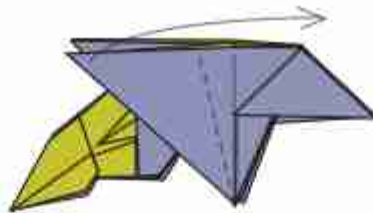

32. Swing back the top flap, along angle bisector thereby creating a new crease.

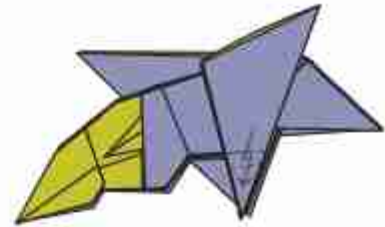

33. Pleat to form feet.

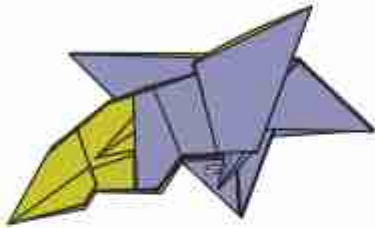

34. Swivel in to narrow the feet.

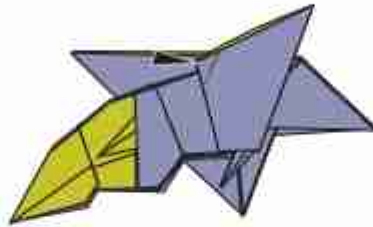

35. Make a tiny reverse fold for the top of the wing.

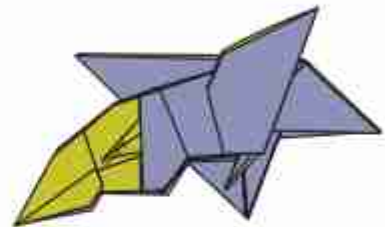

36. Tiny valley fold to create the eye.

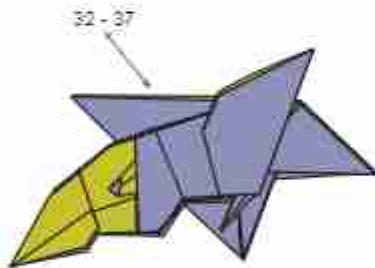

37. Repeat steps 32 - 37 behind.

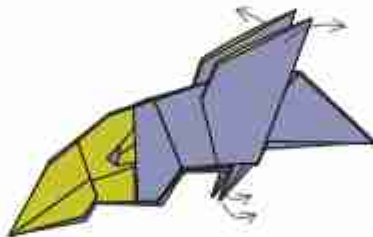

38. Open up the wings and curl the feet. Then rotate to position. The model should stand.

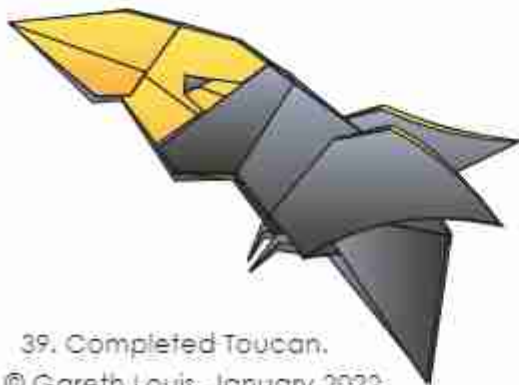

39. Completed Toucan.
© Gareth Louis: January 2022



If the feet are curled appropriately, you can even make the Toucan perch on your finger.

Beautiful Orchid

Linda Marlina
Hadi Tahir. (dgrms.)
©2021 - Indonesia

Intermediate

Paper recommendation: duo color, 8 cm x 8 cm

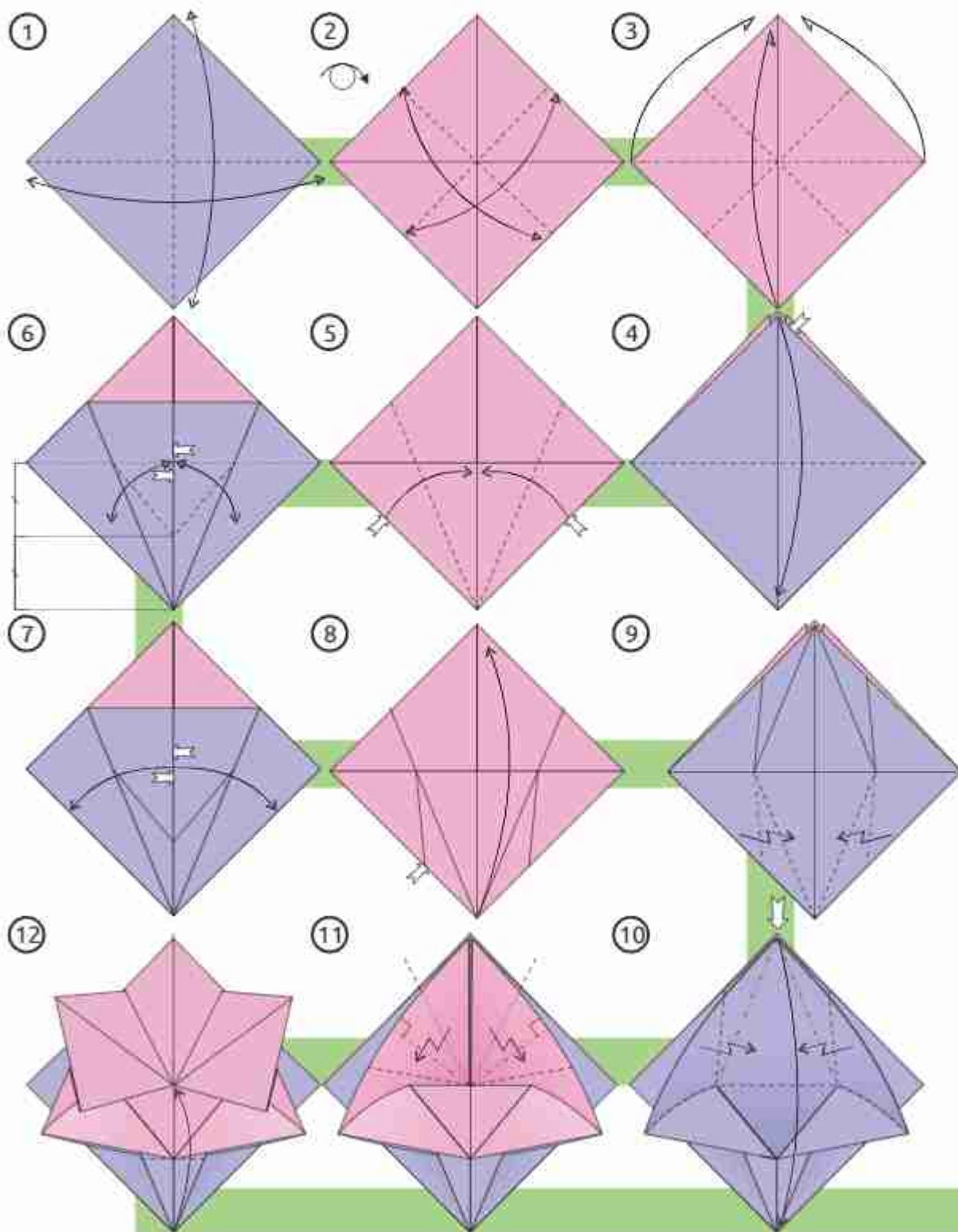

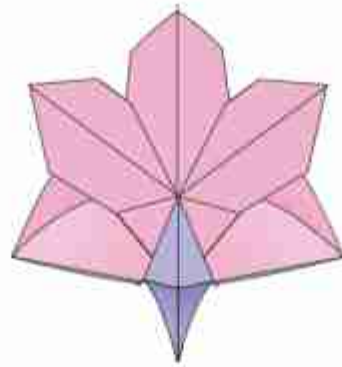

18

curl petals to taste

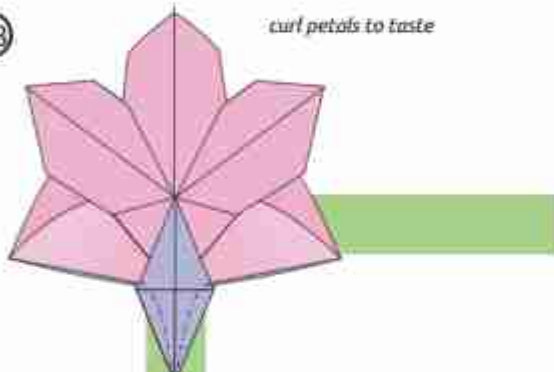

17

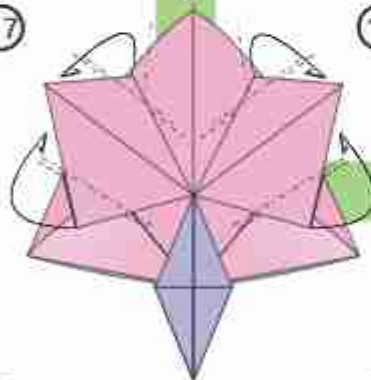

16

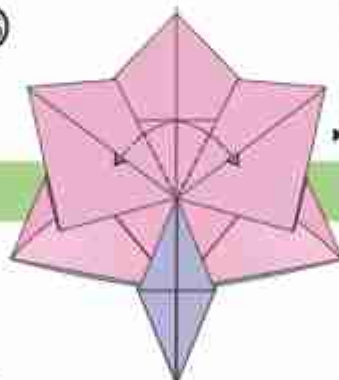

16

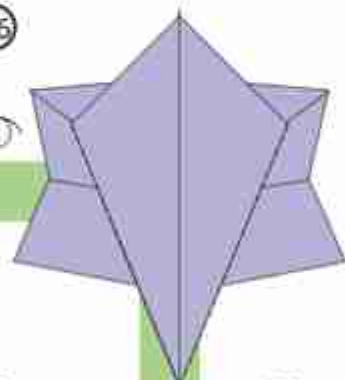

13

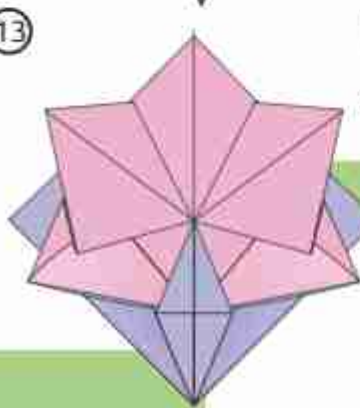

14

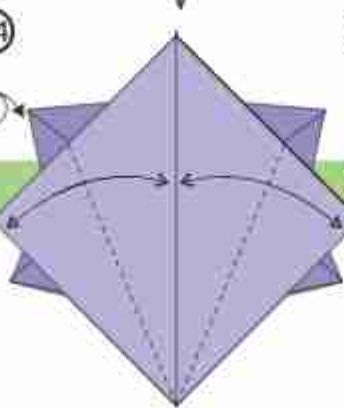

15

inside reverse fold

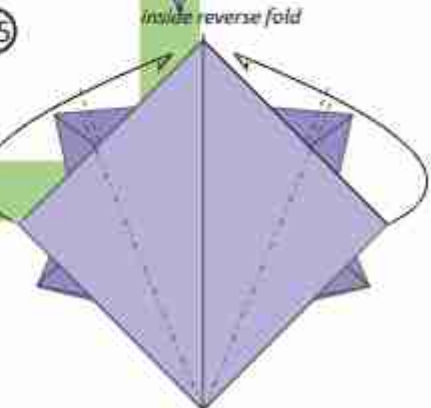

Paper recommendation: 7.5 cm x 15 cm

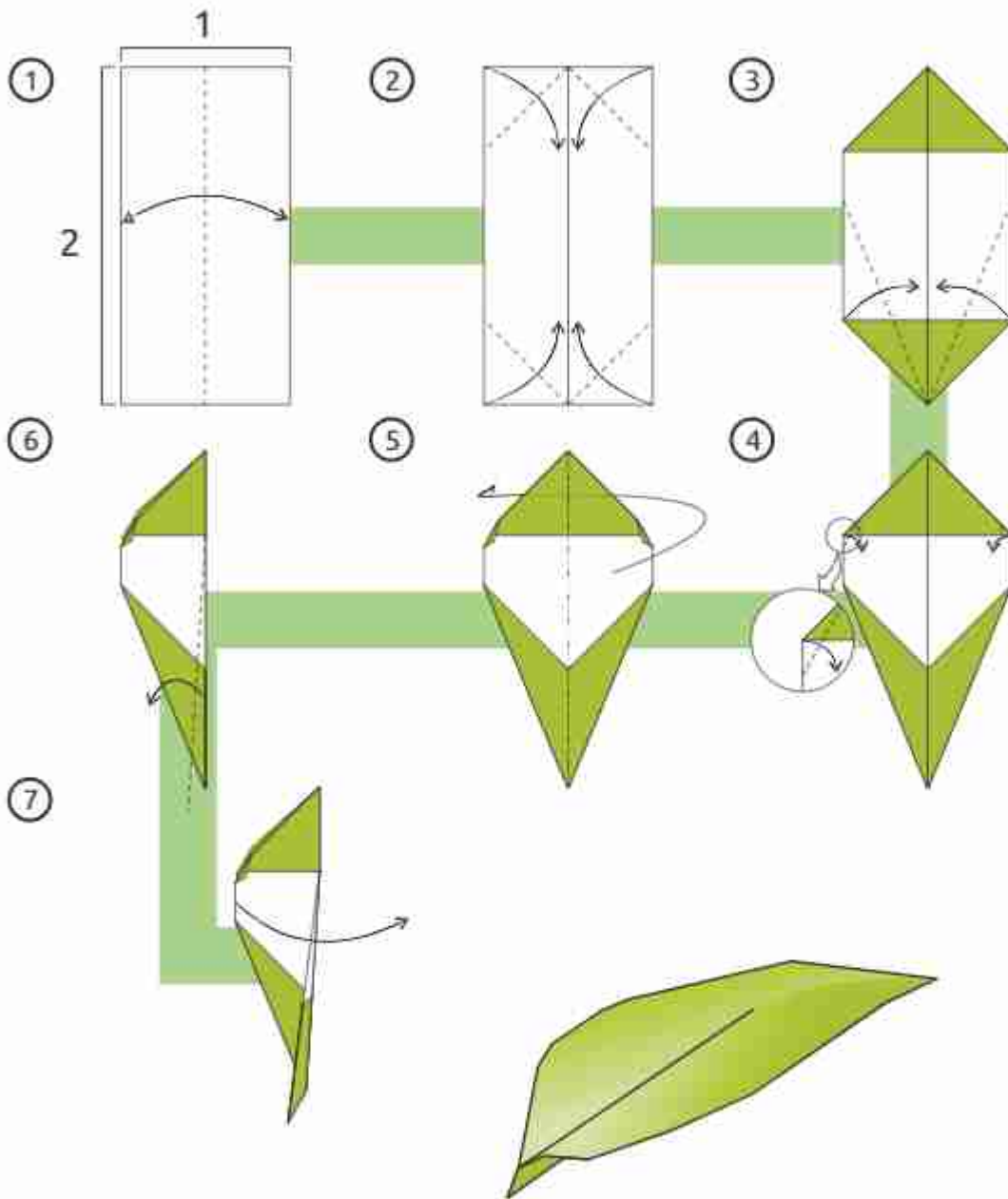

"The name of this model "Anggrek geulis" is taken from the Sundanese language, one of local languages that exist in our country, Indonesia. Anggrek means Orchid and Geulis in Sundanese means beautiful."

Freedom Tower

Nina Mortazavi

©2017 - USA

Low Intermediate

Tehran's most iconic landmark (برج آزادی)

This diagram is for a one-sided-tower. You can also make it two-sided by repeating all the steps on the second layer of the paper, but obviously that will be more complicated. In that case it's recommended to use same color paper in a larger size.

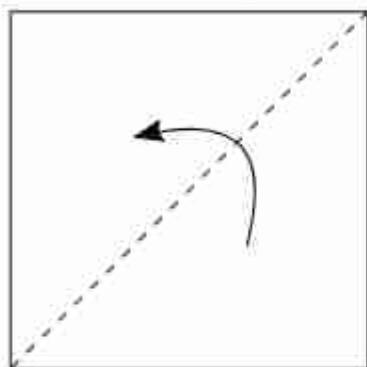

1. Valley fold diagonally

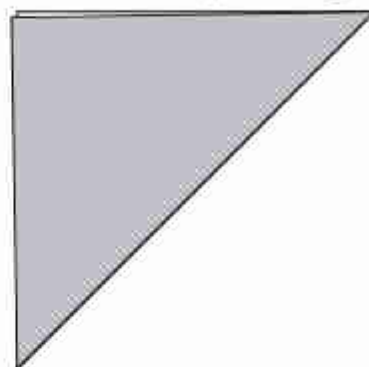

2. Rotate 45 degree clockwise

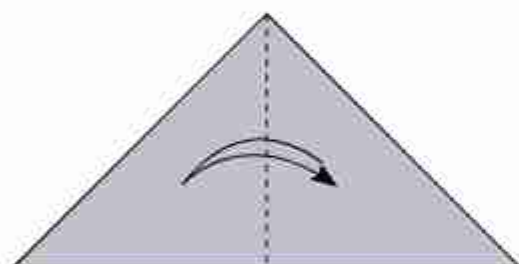

3. Fold and unfold

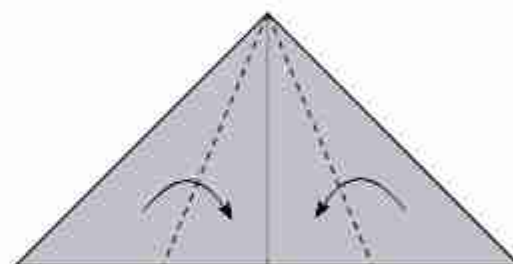

4. Fold each side to the middle crease just created

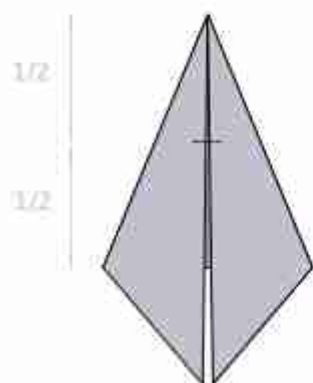

5. Make a pinch in the middle

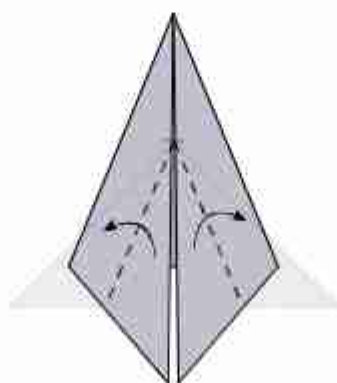

6. Make a valley fold from the pinch parallel to the sides

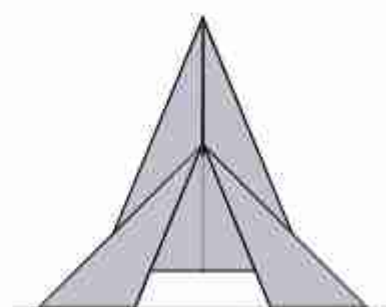

7. Legs should be aligned (as shown)

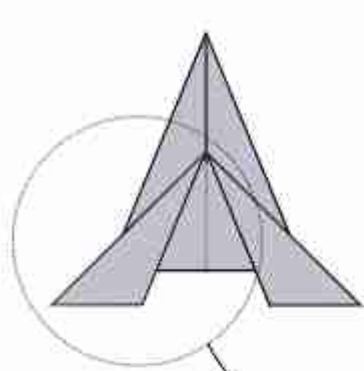

8. Zoom in

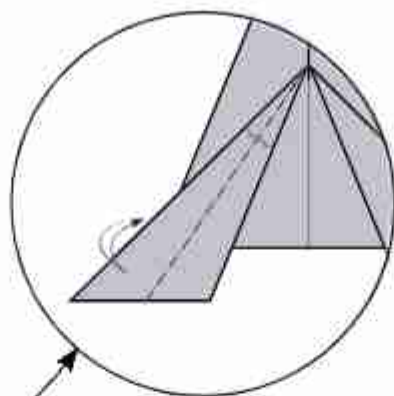

9. Mountain fold
(divide angle to half)

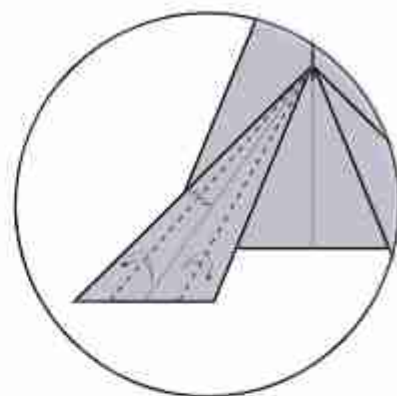

10. Valley or mountain fold
(divide angles to half)

In the last 3 folds (Step 9 & 10),
fold direction is not important.
We only need to create lines
on the legs (Check the final design)

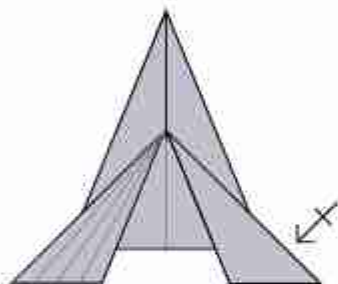

11. Repeat on the right side

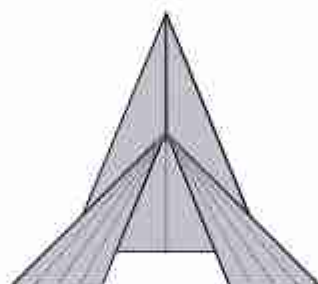

12. Turn over

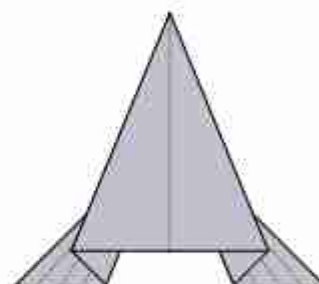

13.

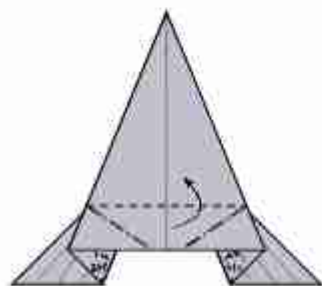

14. Petal fold

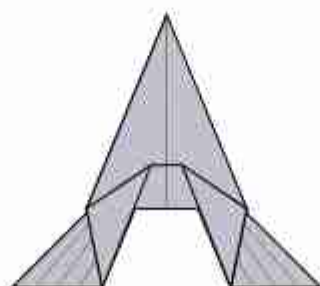

15. Flatten the paper

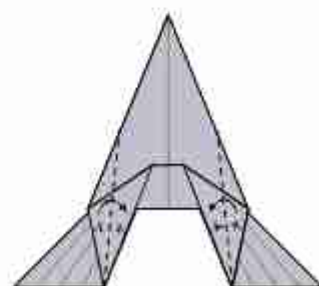

16. Valley fold all layers
except the legs

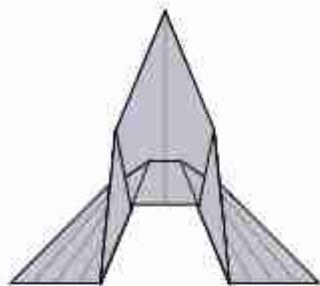

17. Turn over

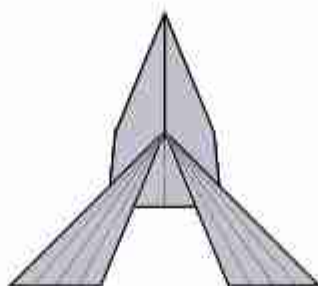

18.

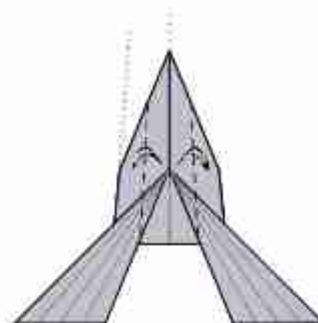

19. On each side, fold all layers from middle to the sides, then unfold

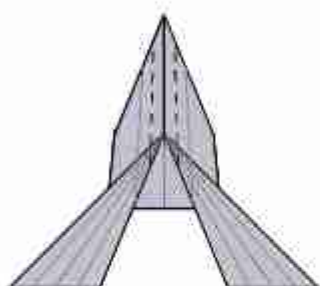

20. Fold in half using the crease created on Step 19 (Top of the tower won't be flat)

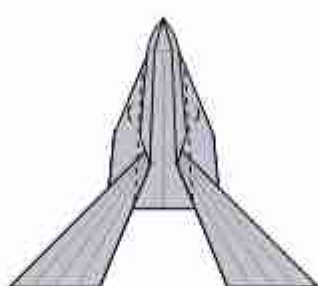

21. Fold along the crease created in Step 19. Bend top of the tower to the back side (still won't be flat)

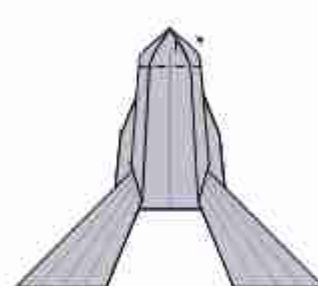

22. Mountain fold. (There is no ref. point) Try to flat the top as much as you can

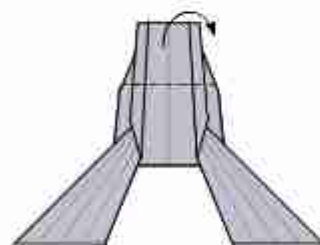

23. Mountain fold. (There is no ref. point)

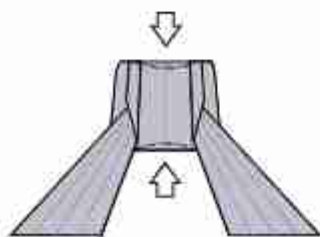

24. Shape the arch and the top

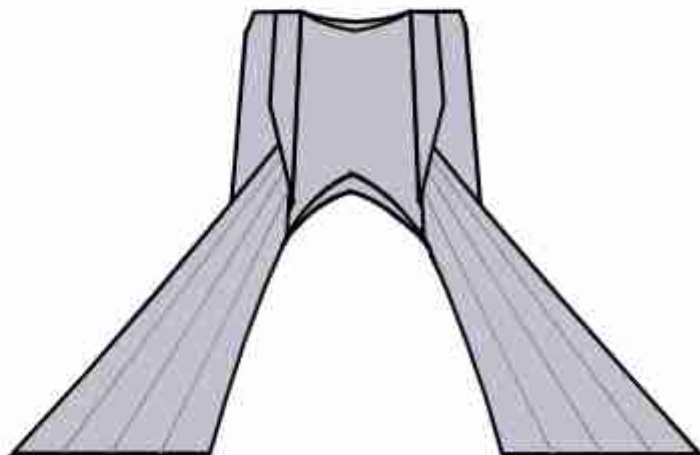

Flawless Ball

Yossi Nir

©2021 - Israel

Intermediate

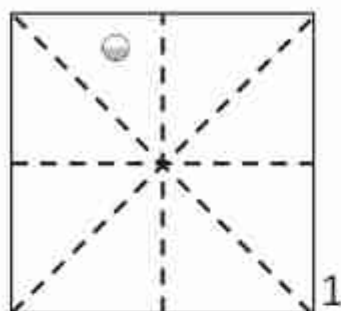

Make valley folds as shown on one paper.

Paper: 12 squares 10X10cm
Paper type: 240 gr/ m² (It can be folded from Kami origami paper too)
Model size: 11 cm diameter.

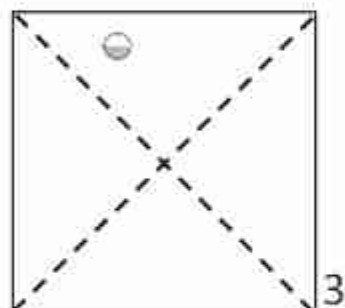

Make valley folds as shown on a second paper.
Turn the paper 45 degrees to the right.

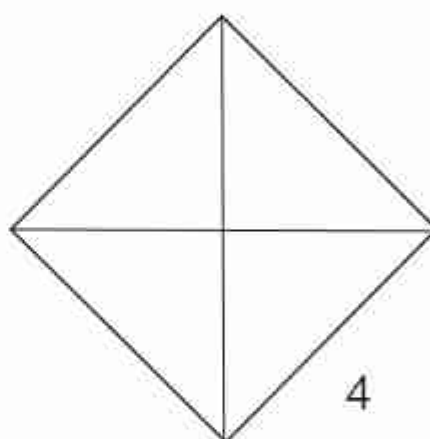

Put the first paper on the second paper.
Make sure that the lines unite in all directions.

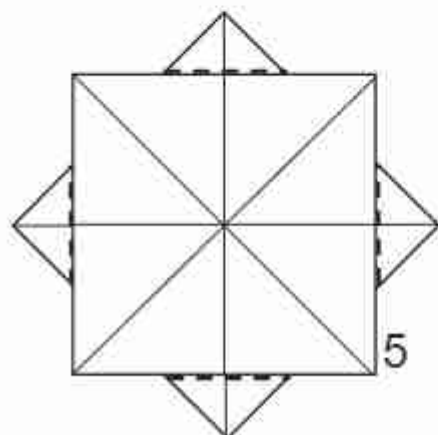

Make valley folds on the first paper as shown

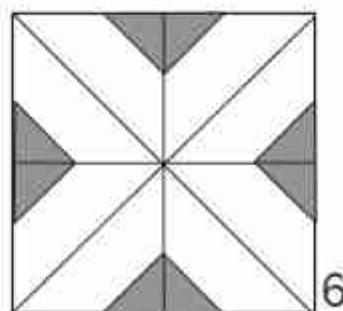

Rotate the paper 45 degrees to the right.



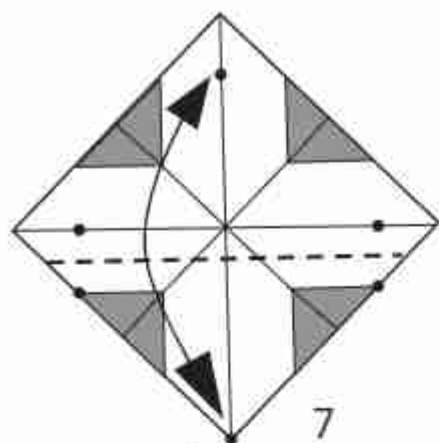

7

Make valley fold as shown.
Repeat 3 more times:

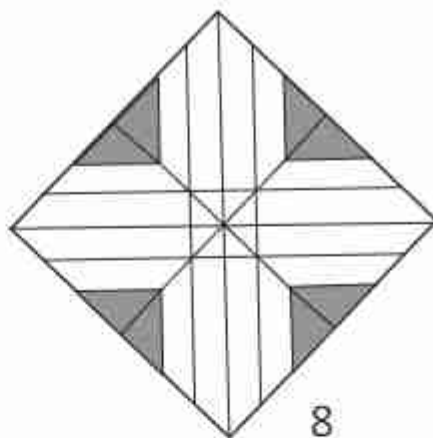

8

Turnover the paper.

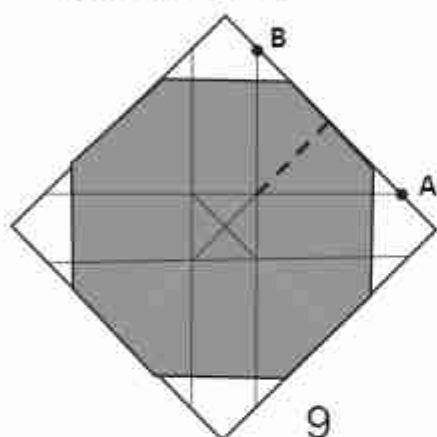

9

Make valley fold as shown
on one paper. Bring A to B and make the crease.
Repeat 3 times more
The model will become 3D. Turnover the paper.

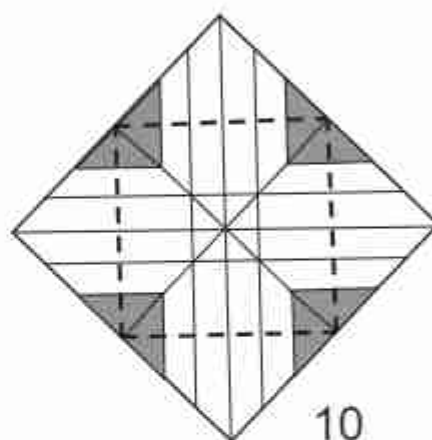

10

Flatten the paper and fold the
4 corners to the center and unfold.
Turnover the paper.

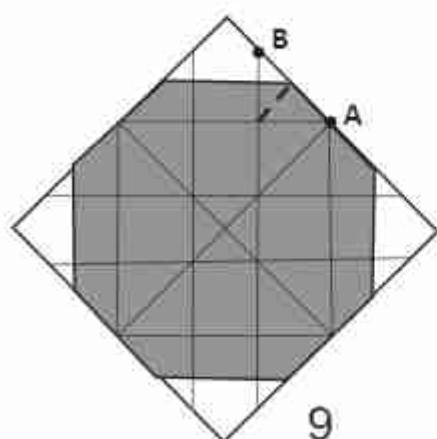

9

Make valley fold as shown
on one paper. Bring A to B and make the crease.
Repeat 7 times more.
The model will become 3D like a dome.

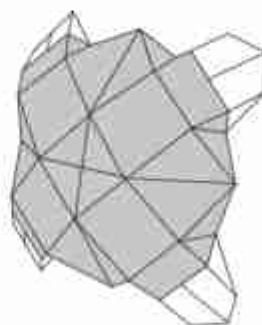

Unit complete

Make more 5 units.

Assembly

Insert the tabs of the 6 units to the pockets to complete the 3D model

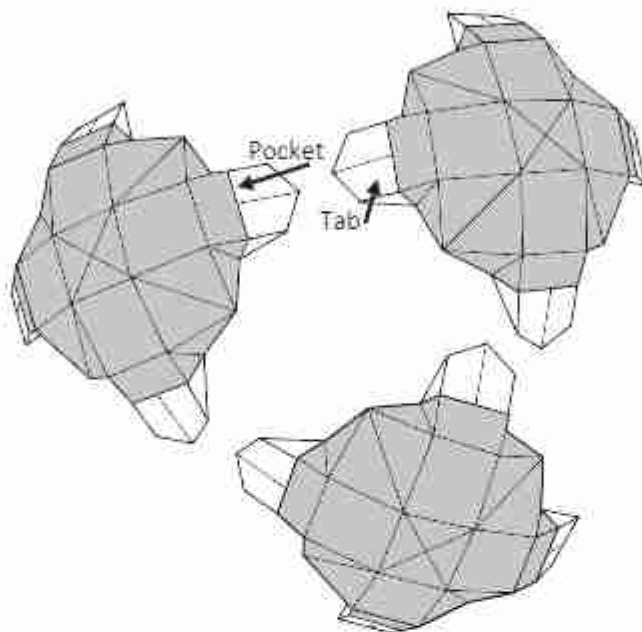

FINISHED

**Ball size calculations
for the "Flawless Origami Ball"
Designed by Yossi Nir**

The unit is about 1/6 of
the surface Area of the Sphere

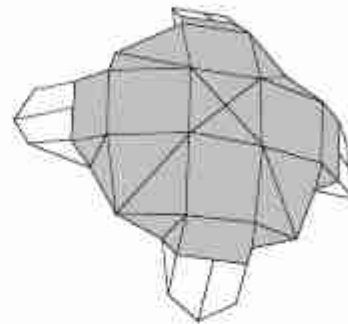

Surface Area of a Sphere in terms of radius:

$$A = 4\pi r^2$$

$$A \approx 12.556r^2$$

For example: If we want a ball with 10 cm diameter
Then

$$A \approx (12.556 * 25) / 6 = 52.3 \text{ cm}^2$$

Since we use a paper with square shape , we need to take the
square root of this number.

$$\sqrt{52.3} = 7.233 \text{ cm}$$

So if we use 7.5x7.5 cm paper we will get a sphere
with diameter of about 10 cm

Another example: If we start with paper with 15X15 cm,
what will be the diameter of the sphere.

$$225 \approx (12.556 * r^2) / 6$$

$$R \approx \sqrt{((225 * 6) / 12.556)}$$

$$R \approx 10.4 \text{ cm}$$

So from a square papers 15X15 cm we will get a sphere with diameter of about 21 cm.

Josefa Star

Maximiliano Ortiz

©2021 - Argentina

Low Intermediate

 12 paper double sided 7,5x7,5 cm

1.

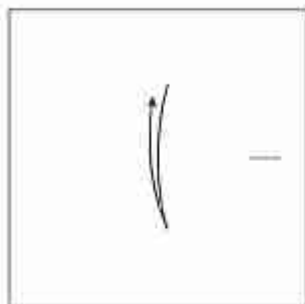

2.

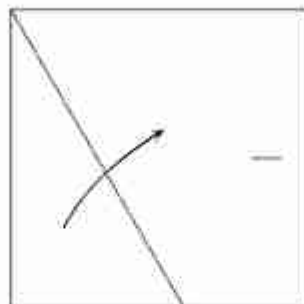

3.

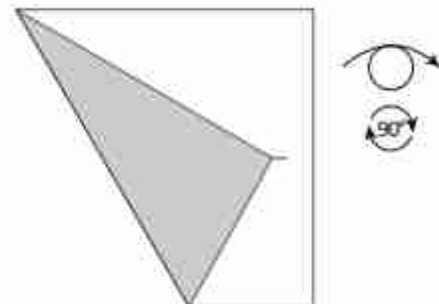

4.

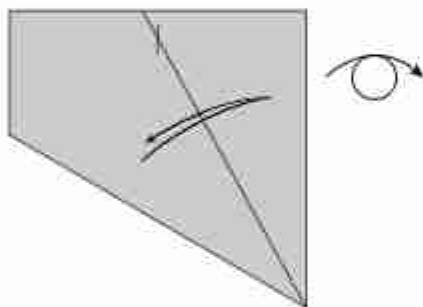

5.

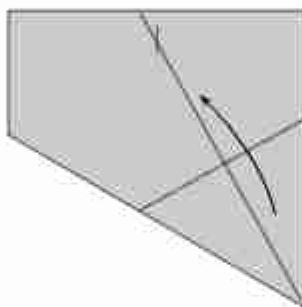

6.

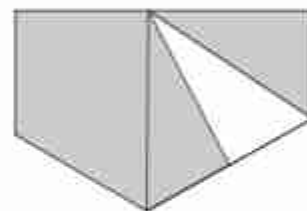

7.

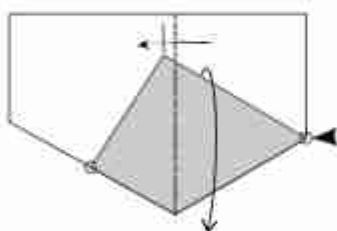

8.

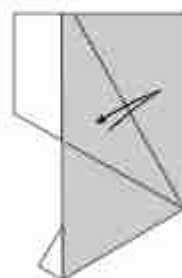

9.

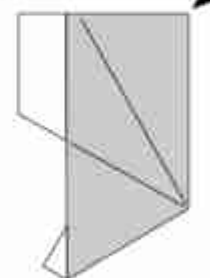

10.

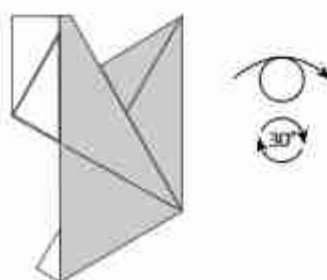

11.

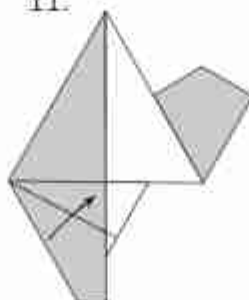

12.

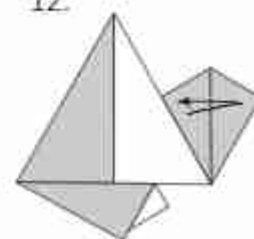

13.

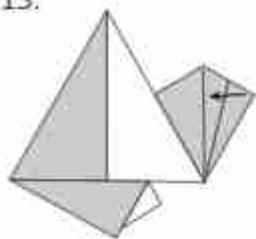

14.

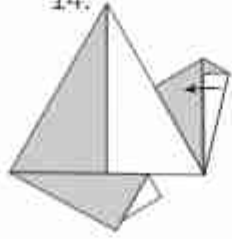

x12

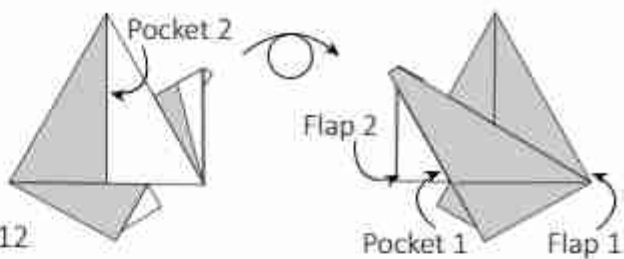

15.

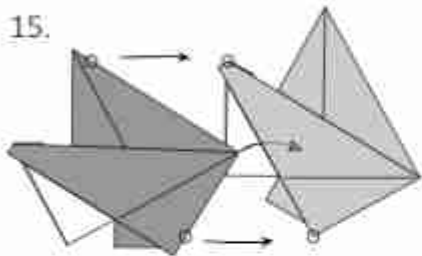

16.

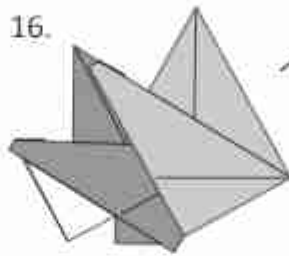

17.

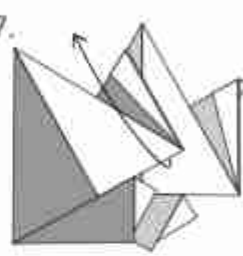

18.

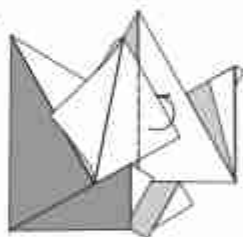

19.

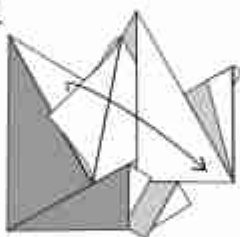

20.

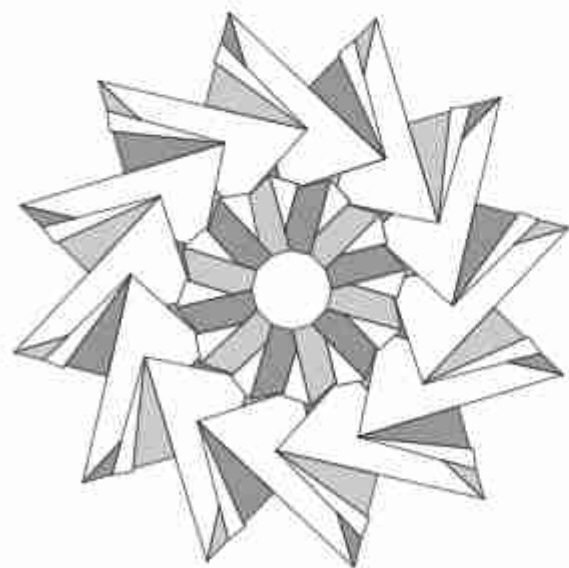
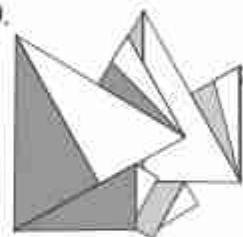

Front

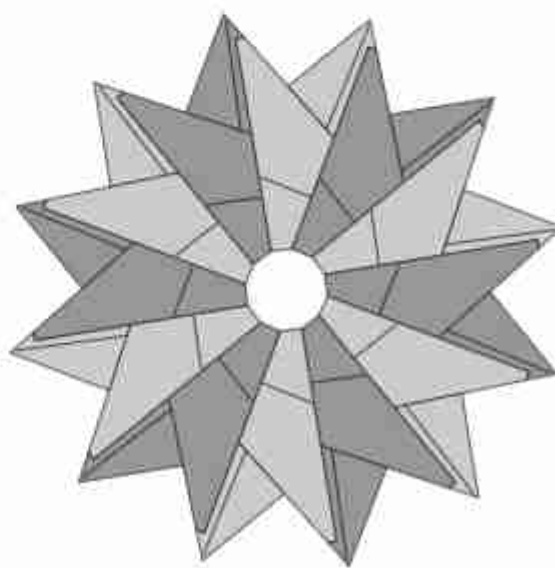

Reverse side

Sitting Dog

High Intermediate

Shriram Patki

©2021 - India

Paper: 15cmX15cm single side colored (any) paper.

1. Start with preliminary base.



2. Rabbit ear fold behind.

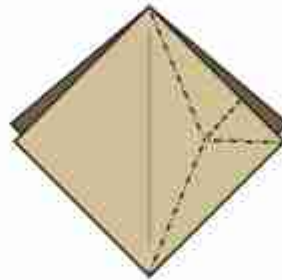

3. Repeat on left side.

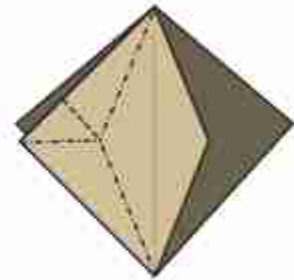

4. Fold as shown.



5. Fold layer to left.



6. Pull out the inner flap and rotate model 45 degrees. See next step.

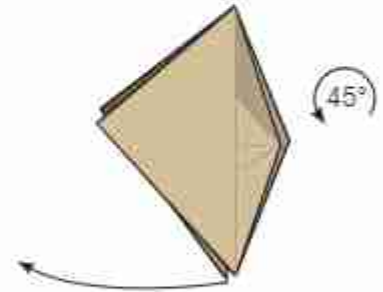

7(a). Swivel point A to the left as you open up flap B. Temporarily raise flap C (the trunk). Then return flap C, extending the fold line. Crease the new flap at. See the next step for the move in progress.

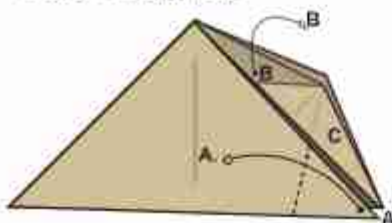

7(b). In progress.

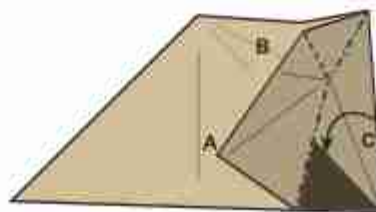

8. Repeat steps 7(a) and 7(b) behind.

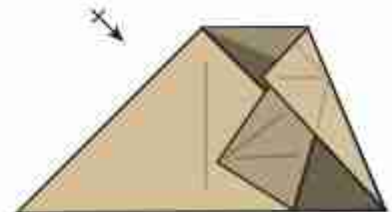

9(a). Precrease and make an open sink. See next step.

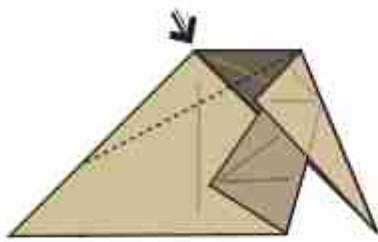

9(b). Top view

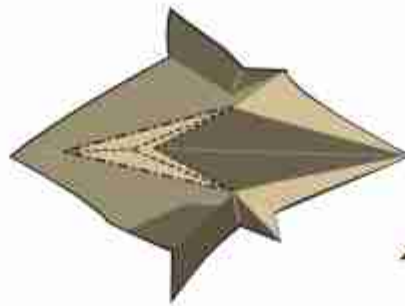

9(c). Side view



10. Crease and valley fold as shown and hold.

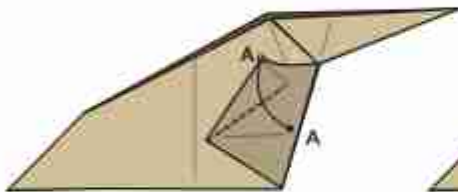

10(a). It will look like this. Now push point B from inside as shown.

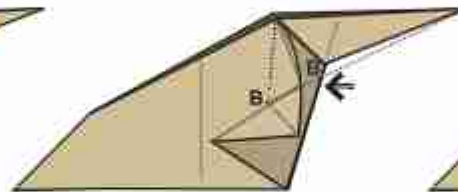

10(b). Valley fold to make ears.

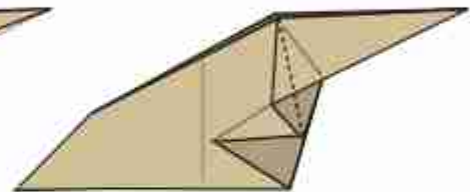

10(c). Valley fold from below ear layer to make front legs.

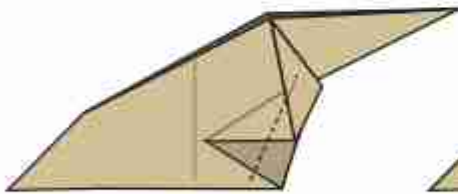

11. Repeat steps 10 to 10(c) on other side.

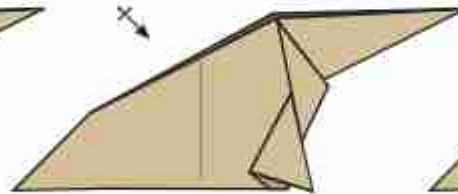

12. Crimp folds as shown.

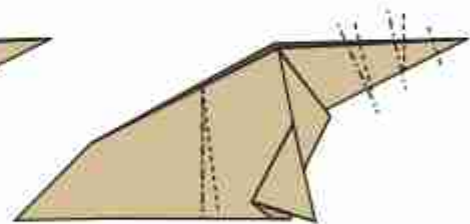

13. Squash from the point A to create nose. Outside reverse fold to make tail.

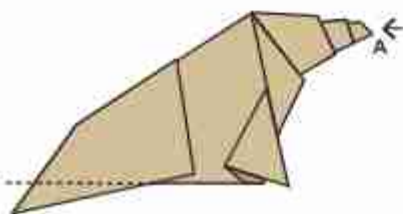

14. Fold inside to make gap between front and back legs.

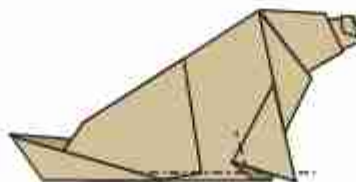

15. Sitting dog is ready.

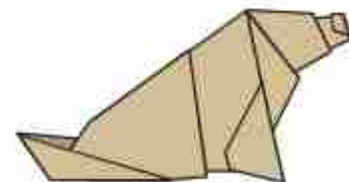

Rabbit

Yehuda Peled

©2020 - Israel

Intermediate

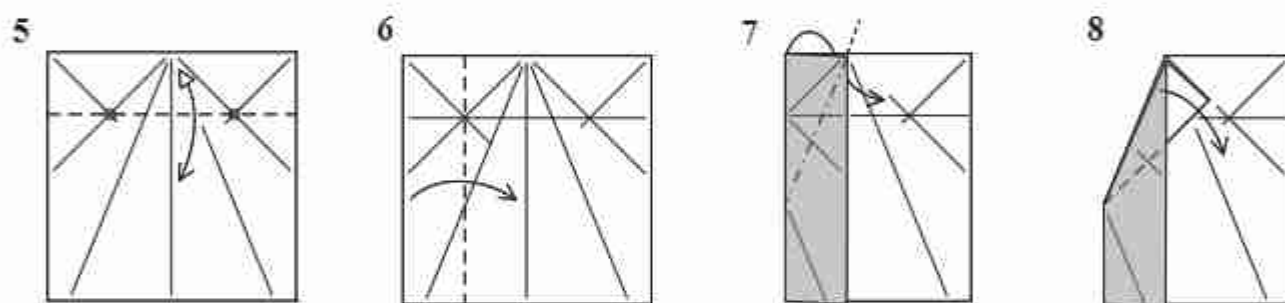
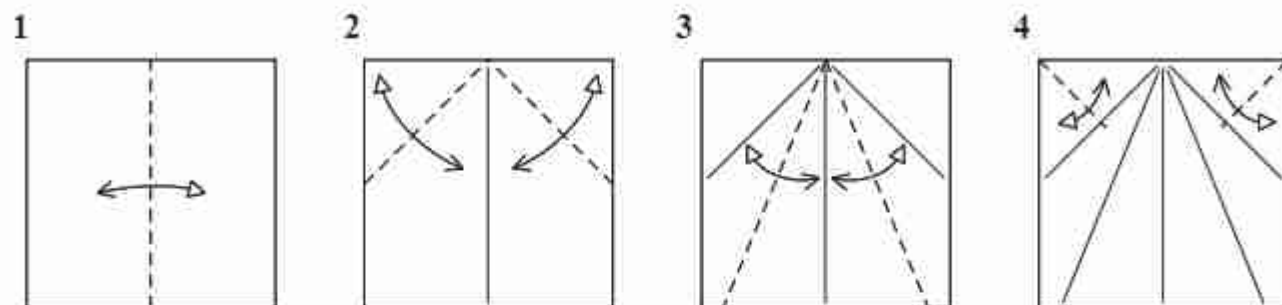

Fold and unfold. Use the reference points.

Open the upper layer.

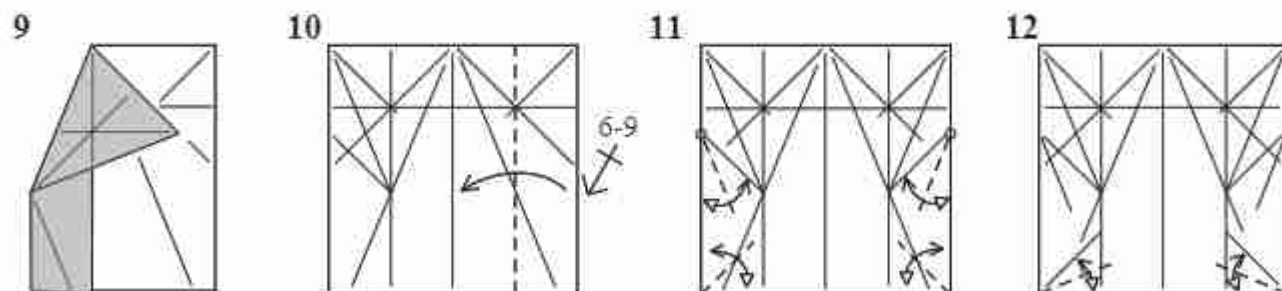

Unfold all.

Repeat steps 6-9 on the other side.

Bisect using the reference points.

13

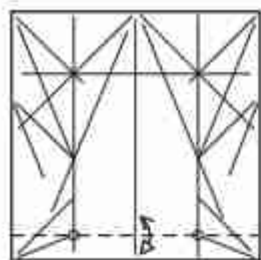

Valley fold using the reference points.

14

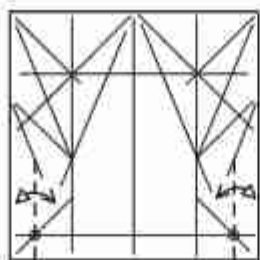

Fold and unfold perpendicular to lower edge using the reference points

15

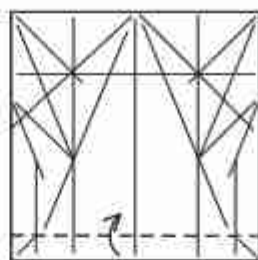

16

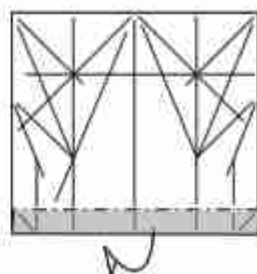

Mountain fold.

17

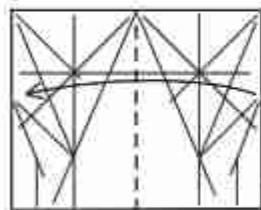

18

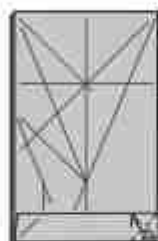

19

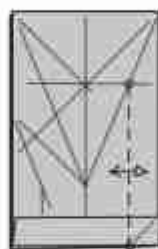

Fold all layers.
Unfold to step 17.

20

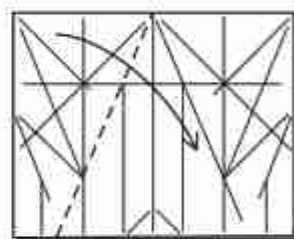

21

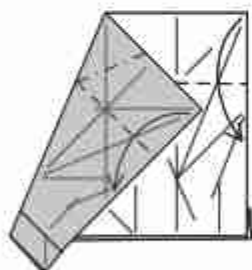

Swivel use the existing creases.

22

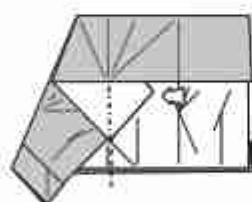

Inside reverse fold.

23

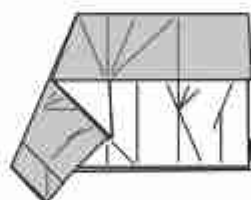

Unfold to step 20.

24

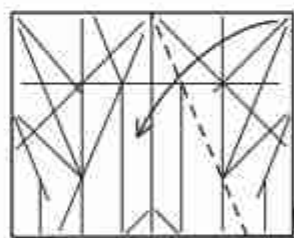

Repeat steps 20-24
on the other side.

25

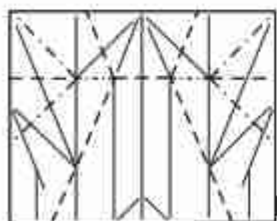

Collapse both side
together.

26

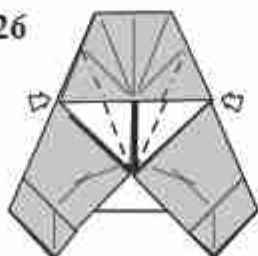

Inside reverse fold.

27

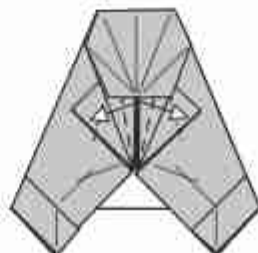

Inside reverse fold.

28

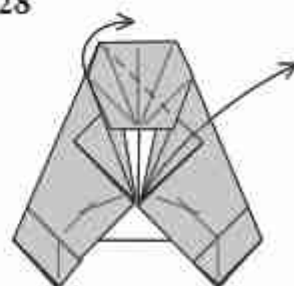

Open the upper layer.

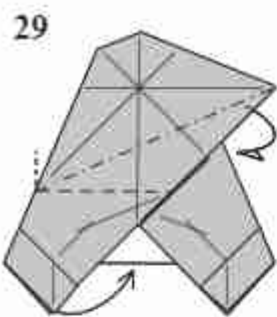

Swivel using the existing creases.

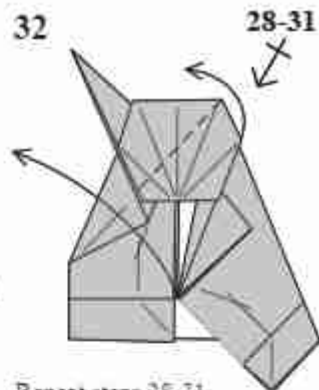
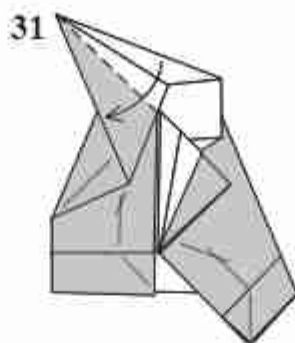
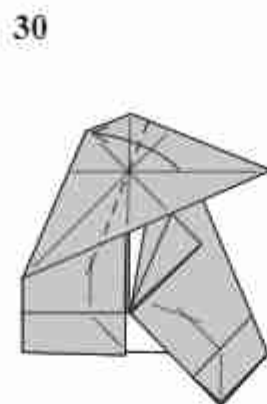

Repeat steps 28-31 on the other side.

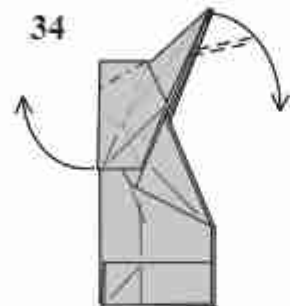
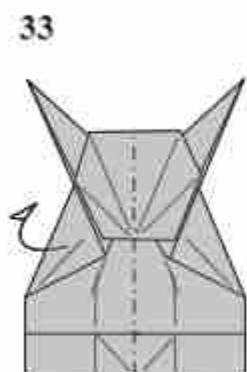

Rotate the head. Pay attention to the hidden edges and hidden valley fold.

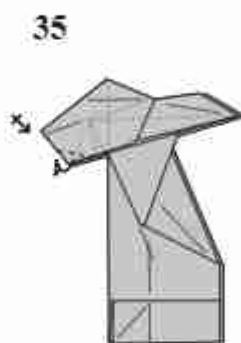

Open two layers.

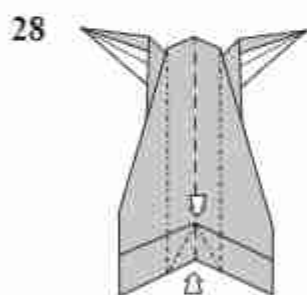

Back view. Fold using the existing creases. Pull the center out. The model will be 3 dimensional.

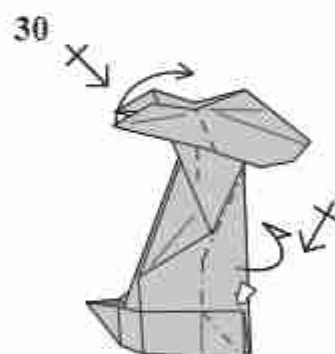
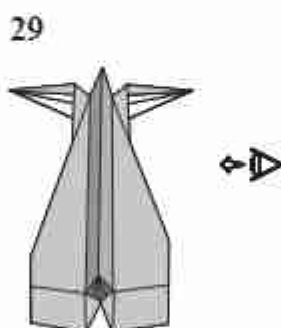

Side view. Fold using the existing creases. Shape the ear. Repeat on the other sides.

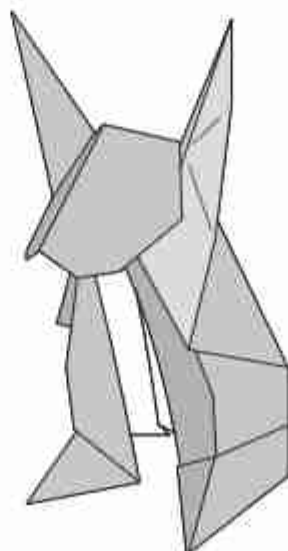
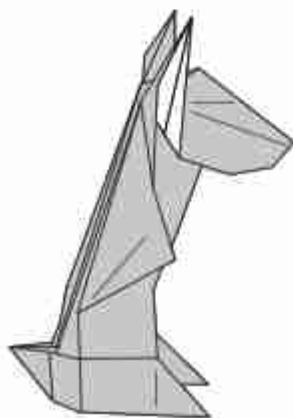

Flexi Fish Form

Nick Robinson

©2020 - England

Low Intermediate

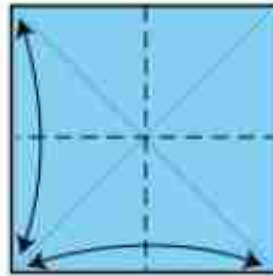
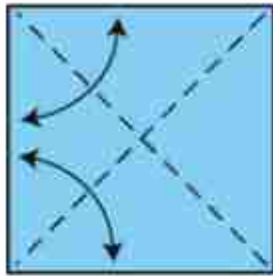

the creases in step 2 are for location only - you could fold a square in half and use it as a template if you don't want them!

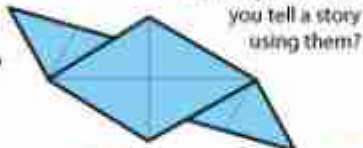
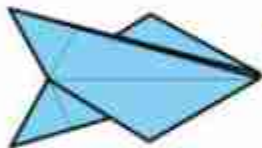

some options - can you tell a story using them?

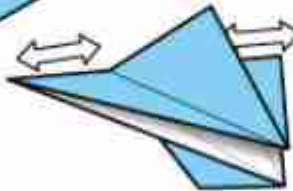
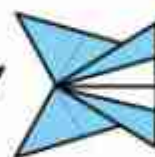
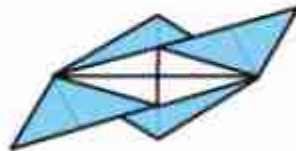
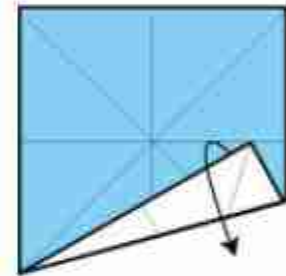
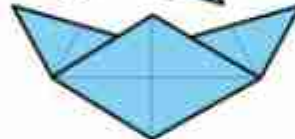
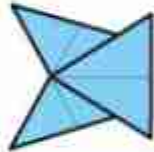

the shape above forms an equilateral module.

x2

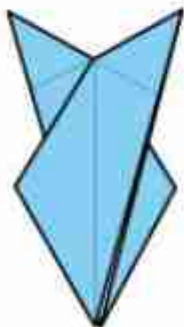

a 3D collapse, like a fish base

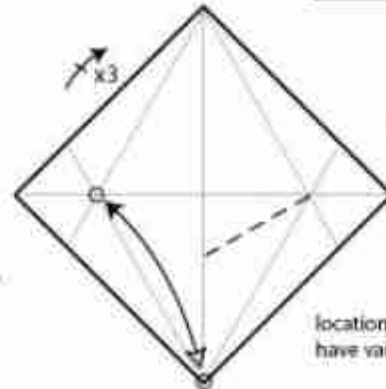
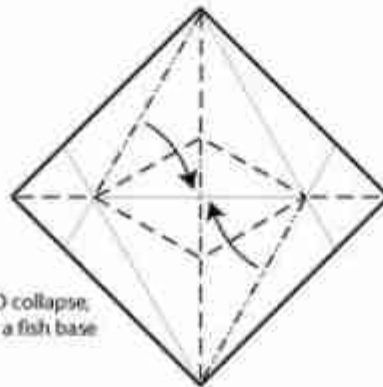

location creases have vanished!

Hermit Crab

Nick Robinson

©2020 - England

Simple

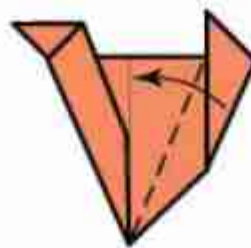
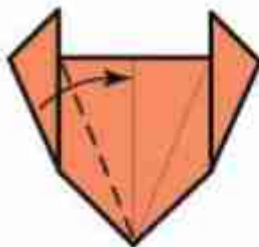
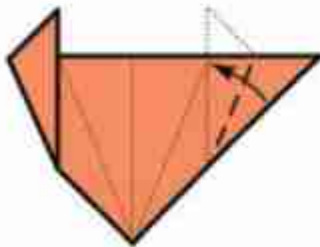
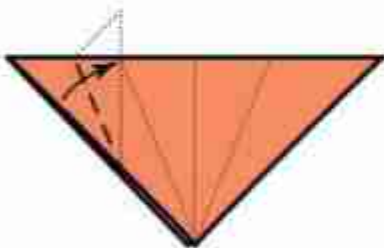
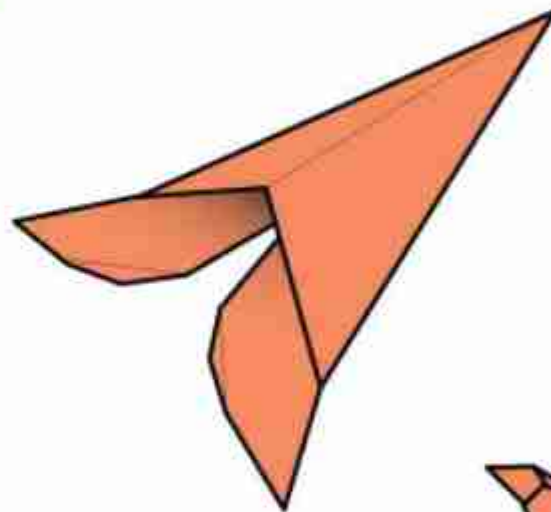
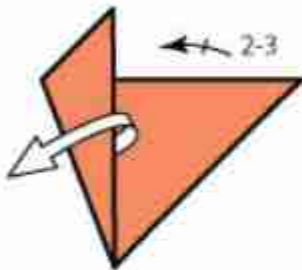
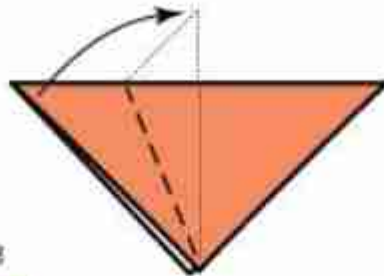
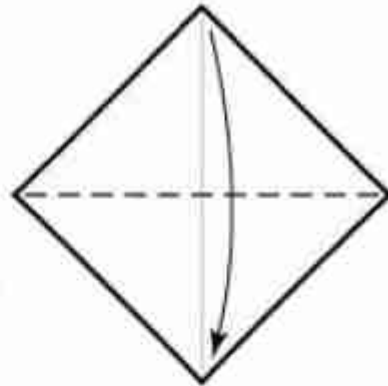

Hexagonal Coaster

Nick Robinson

©2020 - England

Low Intermediate

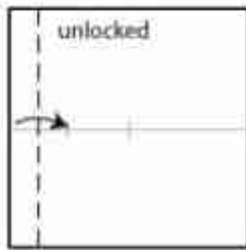

③U

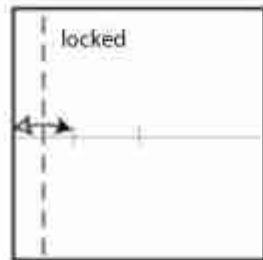

③L

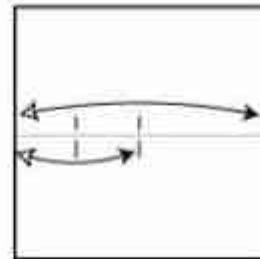

②

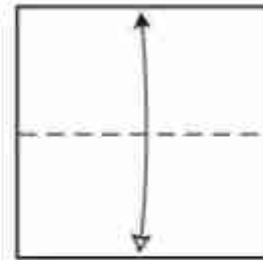

①

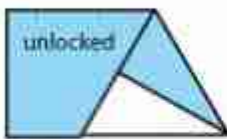

fold as 4-5

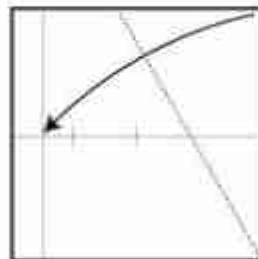

④

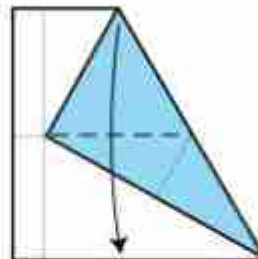

⑤

This is my "Equiphant" unit. It has other modular possibilities!



⑥ Fold 5 locked units and 1 unlocked.

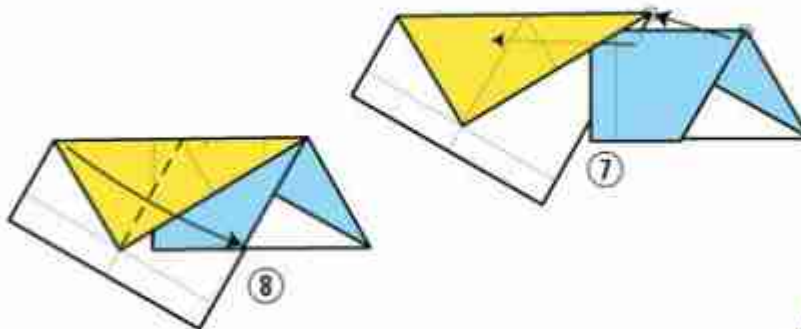
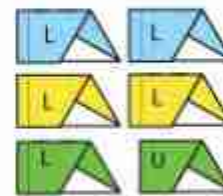

⑦

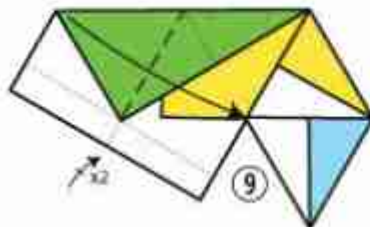

⑧

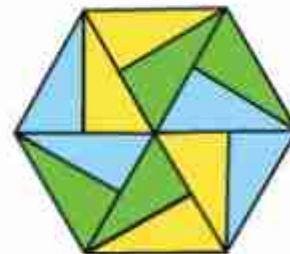

⑨

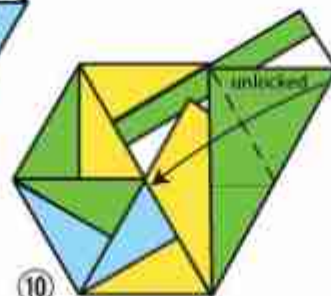

⑩



⑪

Gently bend the green flap and insert it into the blue pocket.

Leftover Flower

Nick Robinson

©2020 - England

Simple

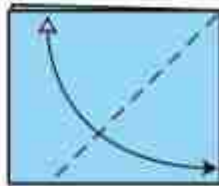

②

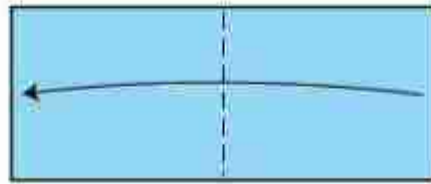

①

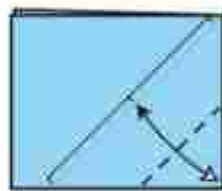
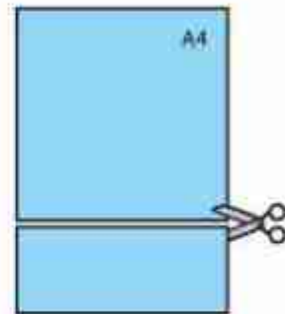

③ make a small pinch if you can't guess!



④

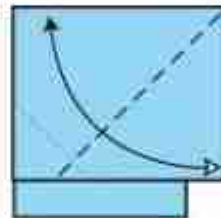

⑤

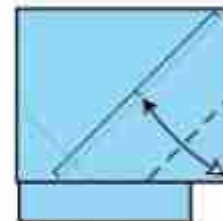

⑥ make a small pinch if you can't guess!

Design by Nick Robinson,
using the "leftover" rectangle
you get when you cut a
square from a sheet of A4.

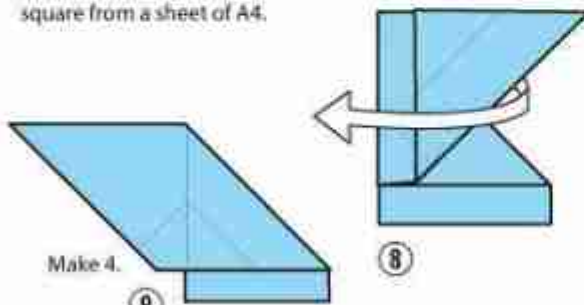

⑧

Make 4.

⑨

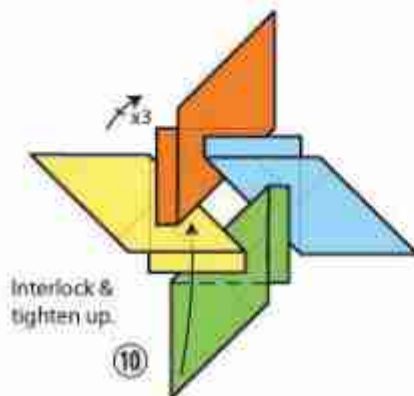

Interlock & tighten up.

⑩

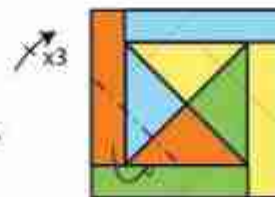

⑪



Any rectangle will
work, up to a 2x1
(shown right)



Crown Star

Rafa Mulyen Samboga

Hadi Tahir (dgrms.)

©2021 - Indonesia

Complex

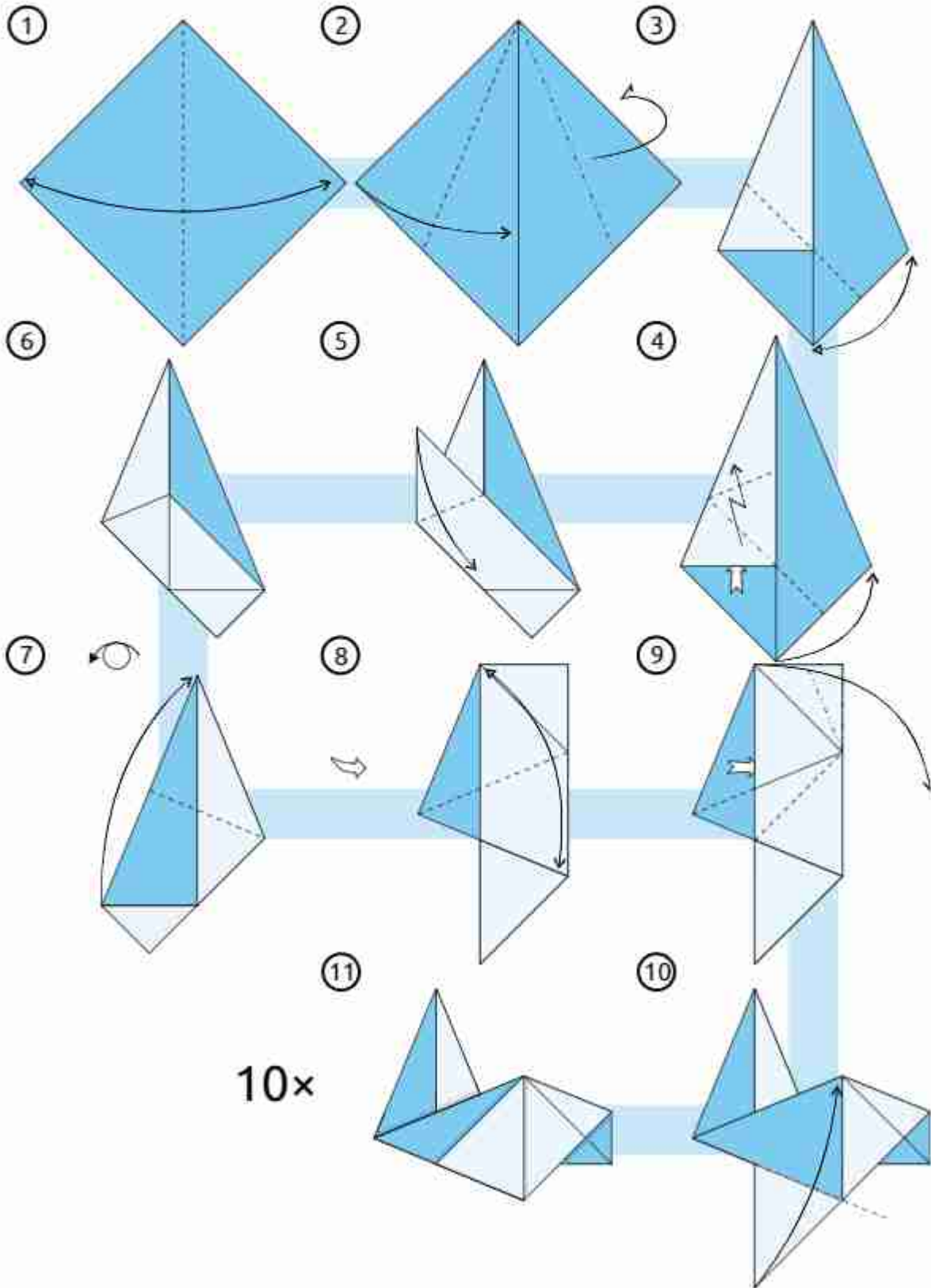

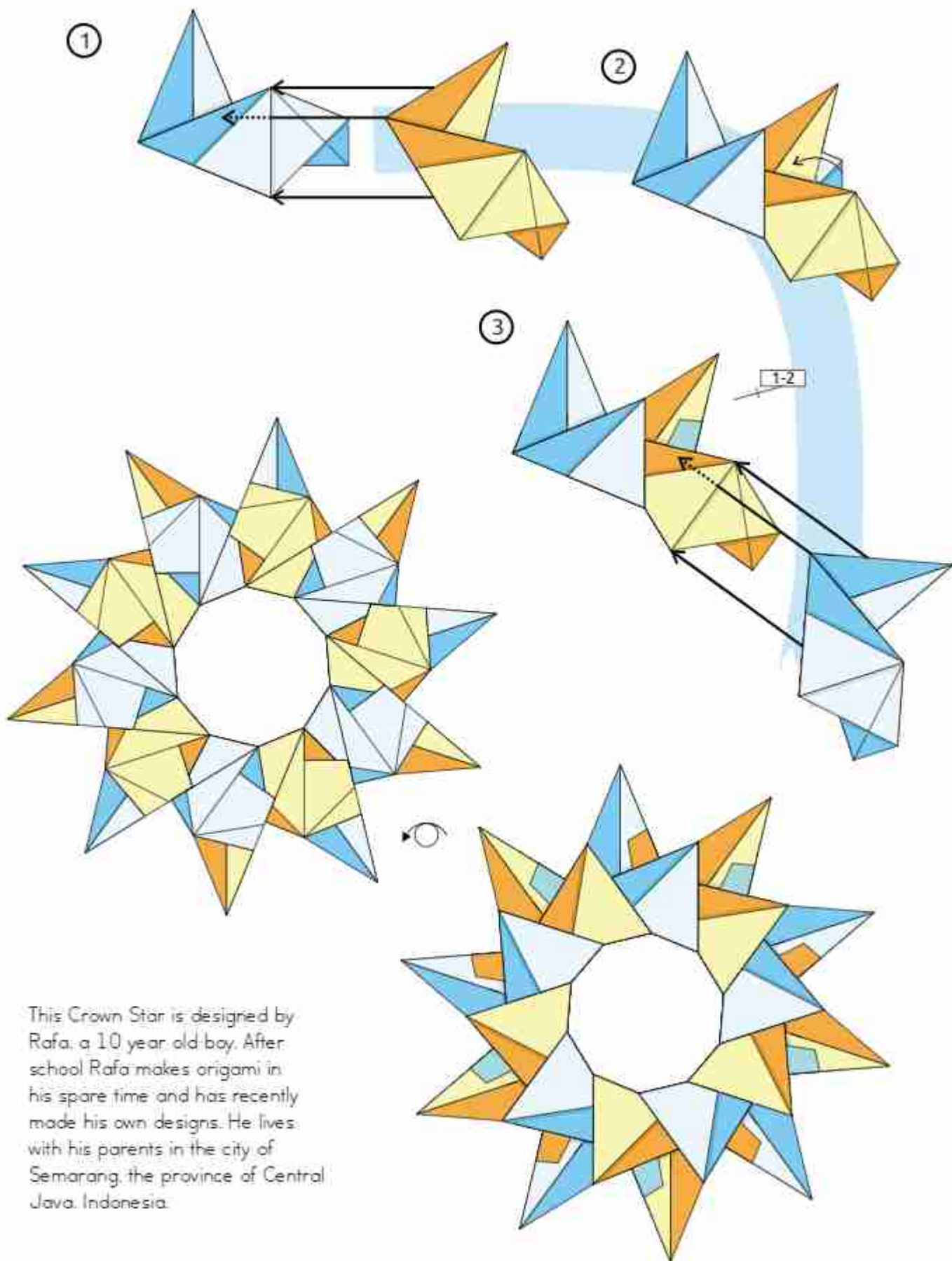

This Crown Star is designed by Rafa, a 10 year old boy. After school Rafa makes origami in his spare time and has recently made his own designs. He lives with his parents in the city of Semarang, the province of Central Java, Indonesia.

Hay modelos que una vez diseñados o plegados son especialmente bonitos, al menos para su creador. Aunque es un modelo de apariencia compleja su proceso de plegado es especialmente sencillo, no acumula capas en ningún sitio y mantiene su forma sin necesidad de humedecerlo. Tan solo un paso, el número 22, es algo más complicado aunque al tener los pliegues ya marcados sale casi sólo una vez sabes cómo hacerlo. Este base es bastante prolífica y es sencillo elaborar distintos animales con cuernos o largas orejas.

There are models that once created and folded are specially nice at least for the creator. Even though it looks complex, it is simple to fold, it doesn't accumulate paper's layers and holds its form once folded with no need to wetfold it. Only one step, number 22, is a little bit more complex but because creases are already marked it folds nearly alone once you know how to do it. This base is prolific and it is simple to create animals with horns or long ears.

①

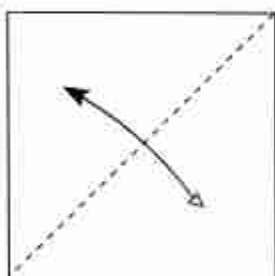

②

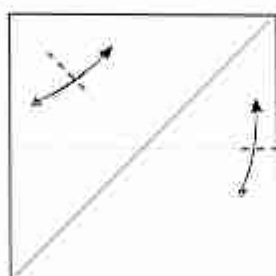

③

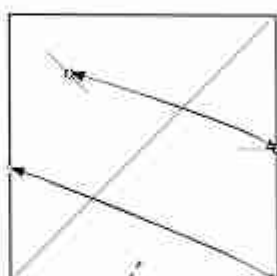

④

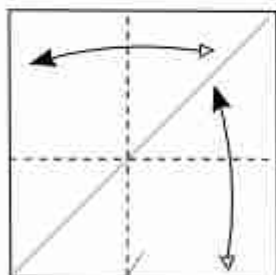

⑤

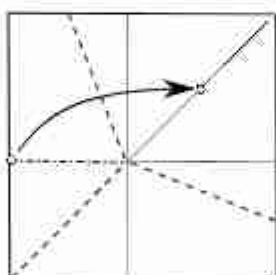

⑥

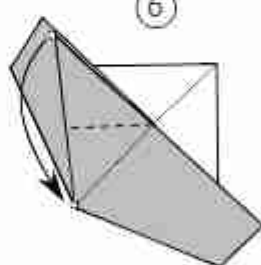

⑦

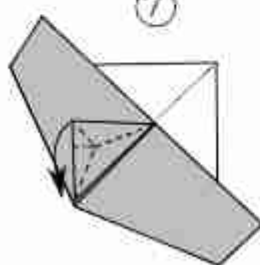

Oreja de conejo
Rabbit ear

⑧

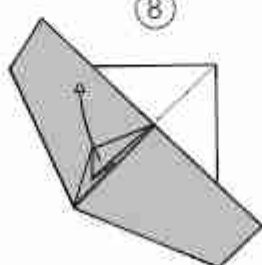

⑨

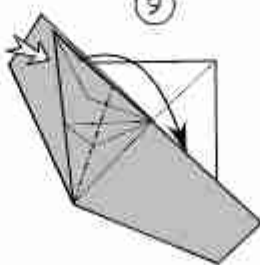

⑩

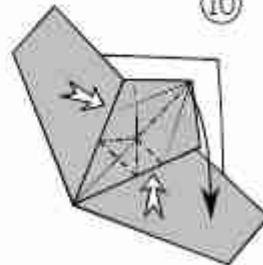

Doblar sobre las líneas existentes
Fold on existing creases

11

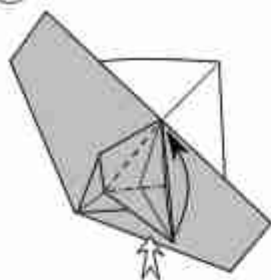

12

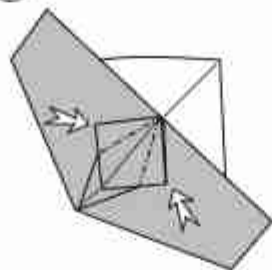

13

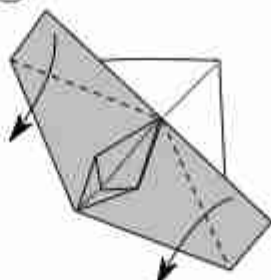

14

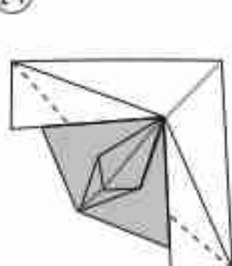

15

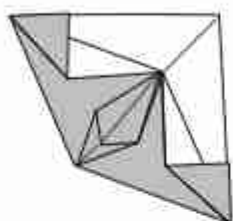

16

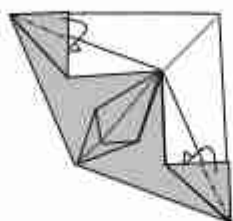

17

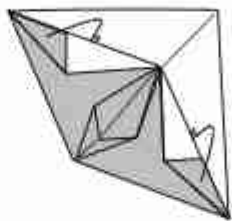

18

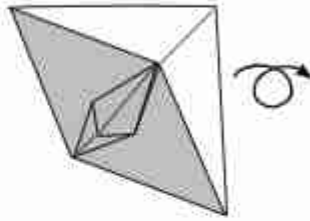

19

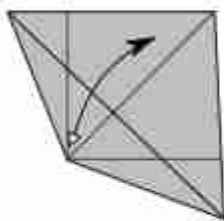

20

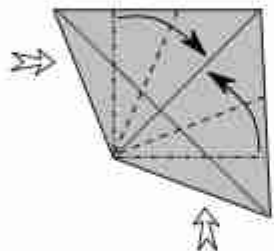

21

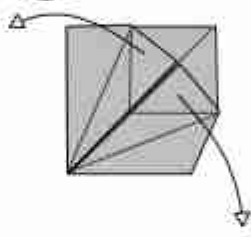

Desdoblar todo
Unfold everything

22

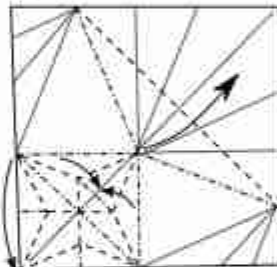

23

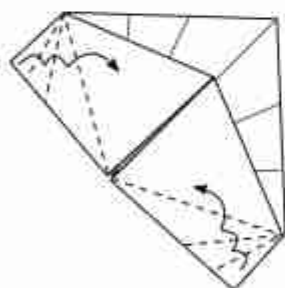

Doblar sobre las líneas existentes
Fold on existing creases

24

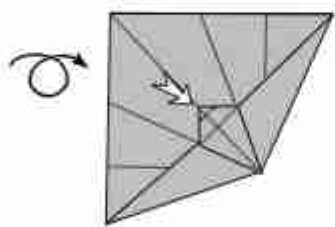

25

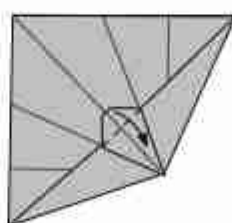

26

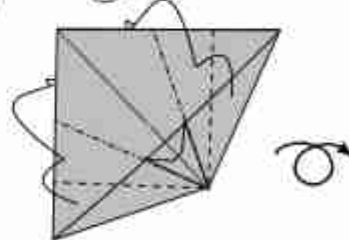

27

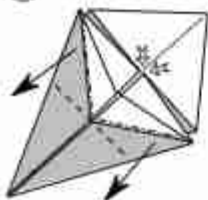

28

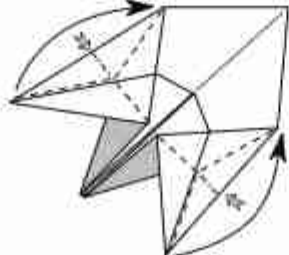

29

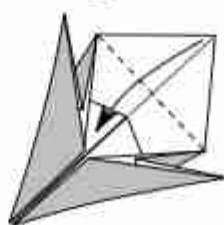

30

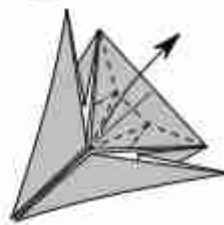

Doblar sobre las líneas existentes.
La punta central de la base pájaro
tiene que quedar por fuera
Fold on existing creases. The middle
flap in the bird base is in the outside

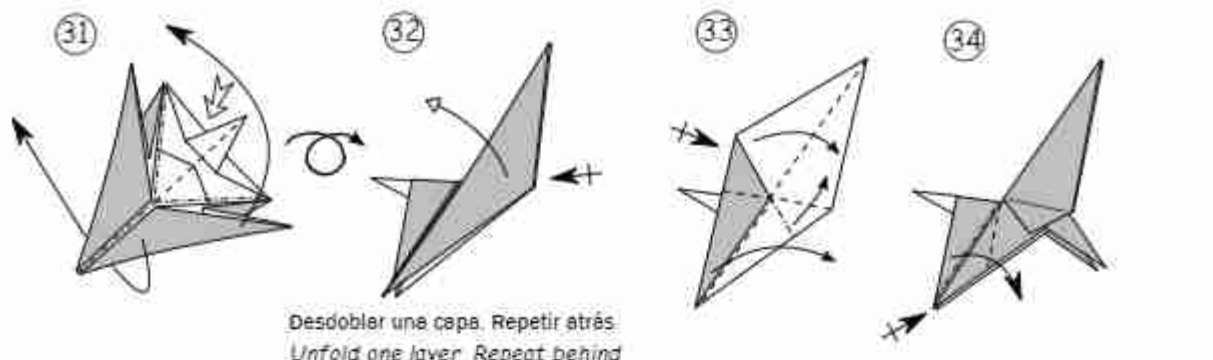

Desdoblir una capa. Repetir atrás.
 Unfold one layer. Repeat behind.

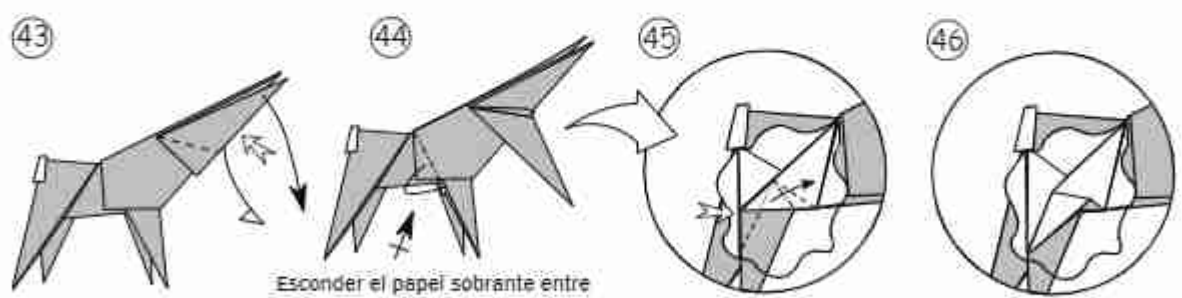
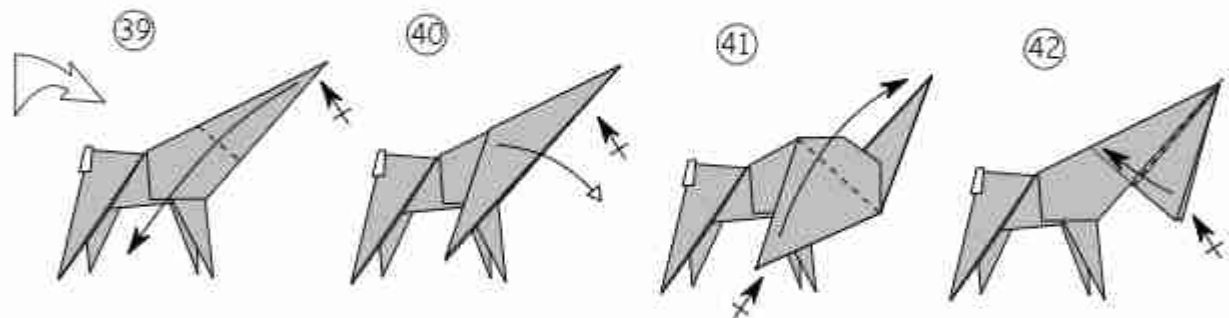
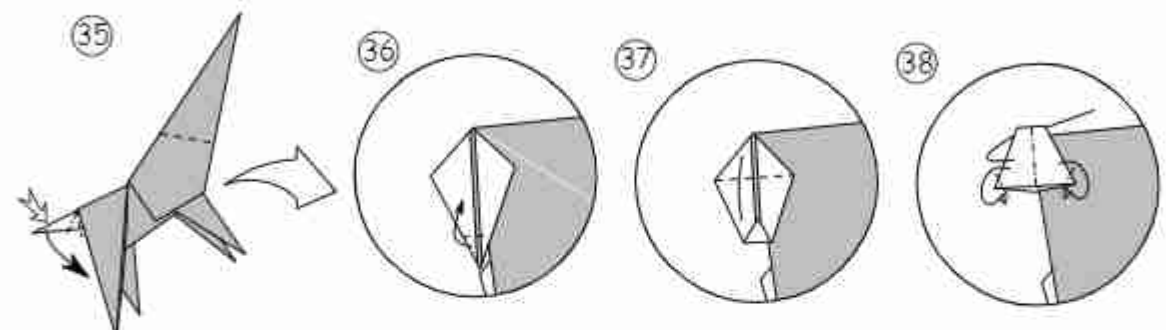

Esconder el papel sobrante entre las dos capas de cada pata.
 Hide the excess paper between the two layers of each leg.

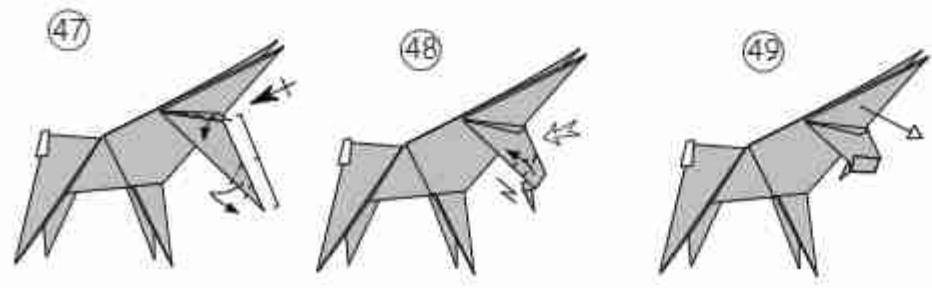

Los siguientes pasos solo para hacer cambio de color en los cuernos. El resto del modelo estaría terminado.
 Next steps only to color change the horns. The rest of the model is finished.

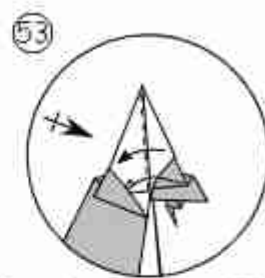
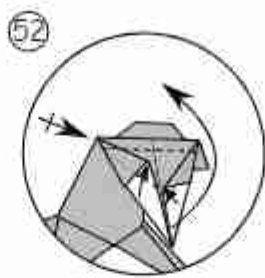
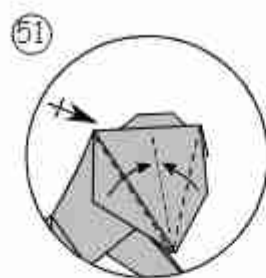
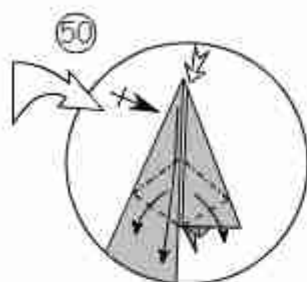

Doblar por la mitad. La pestaña de la derecha se mete en el bolsillo de la izquierda para sujetar la oreja.
 Fold in half. The right flap goes into the pocket on the left to hold the ear.

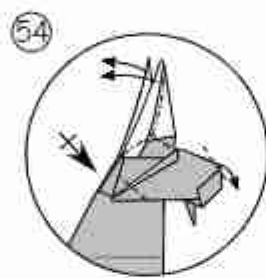
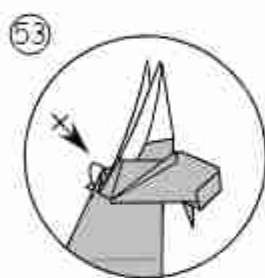

Afinar los cuernos, dar forma a la oreja y hacer un pequeño pinch en la nariz para darle forma.
 Fold the horns in half, shape the ears and make a little pinch in the nose.

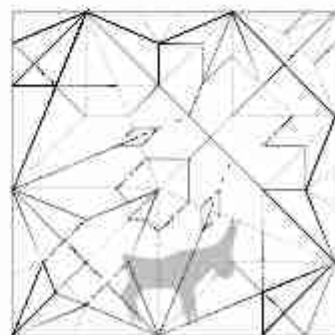
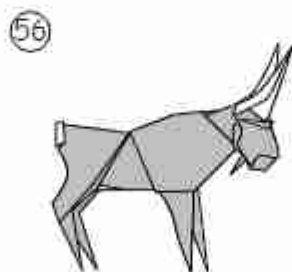
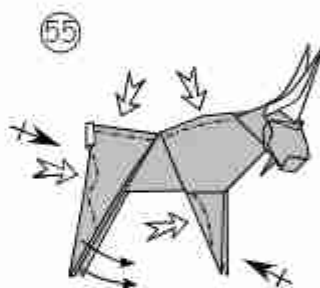

Proporción: 55%

Helix

Intermediate

Fernando Sánchez-Biezma

©2019 - Spain

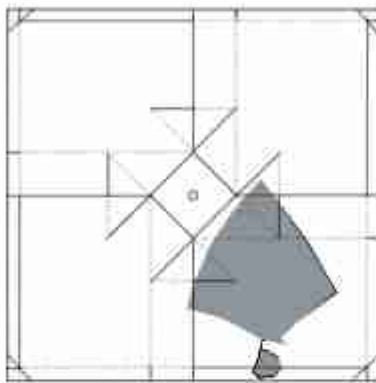

Dificultad / *Level*: Nivel medio / *Medium*
Tiempo de plegado / *Time to fold*: 15 min
Papel / *Paper*: Kami de 15 cm / *Kami* 15 cm
Otros / *Other*:

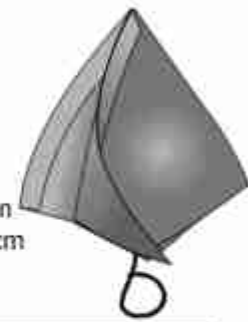

Proporción / *Ratio*: 40%

Una de las figuras más populares de origami es el molinillo. Es raro haber pasado por la niñez sin haber construido al menos uno y haberse divertido soplando una y otra vez. Las figuras que se mueven son de las más llamativas que se pueden plegar y es seguro que llamarán la atención cuando empiecen a girar. Mi hélice pretende ser una figura de las que llaman la atención cuando están en marcha. Parado no destaca pero su rapidísimo giro soplando tanto desde arriba como desde el lateral son una baza ganadora. El plegado es sencillo salvo el paso en el que se le da forma tridimensional.

One of the most popular origami models is the windmill. It is unusual to have been a child and not to have folded and enjoyed one of them. The moving models are probably the most popular you can fold and it is sure they will catch anyone's attention once spinning. My helix tries to achieve this goal. It doesn't say much when not moving but its very fast spinning when blown from the side or from the top is a win-win situation. The model is simple except for the steps that make it three dimensional.

①

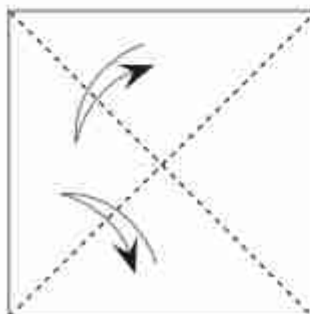

②

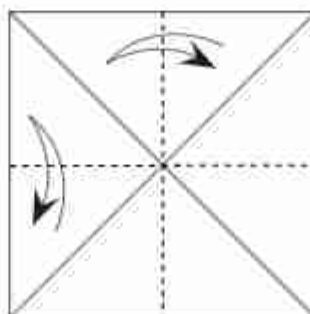

③

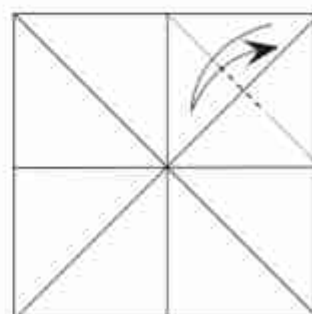

4

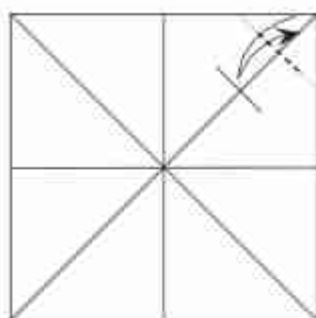

5

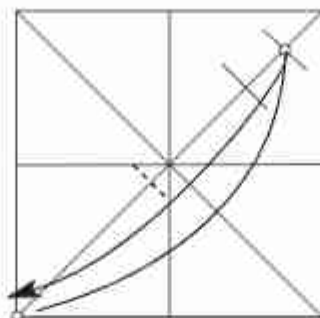

6

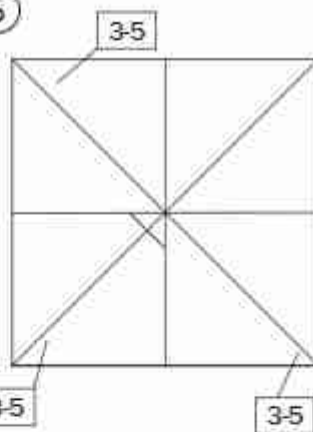

7

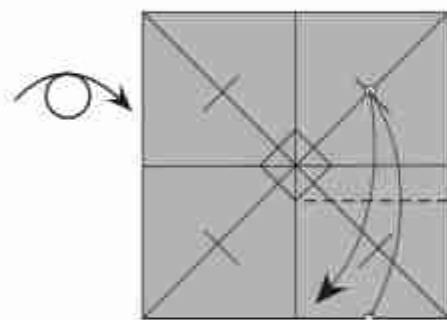

Doblar el lado inferior hasta la referencia marcada en el paso tres. Desdoblar.
Fold the bottom edge to the pinch made in step three. Unfold.

8

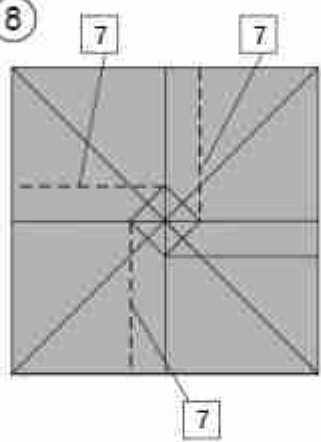

Repetir el paso anterior en los otros tres lados.
Repeat the previous step in the other three sides.

9

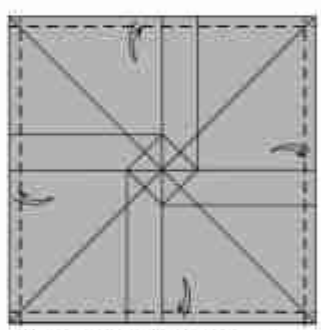

No importa el ancho del pliegue pero si tiene que ser simétrico en los 4 lados.
The width of the fold does not matter but it has to be symmetric along the 4 edges.

10

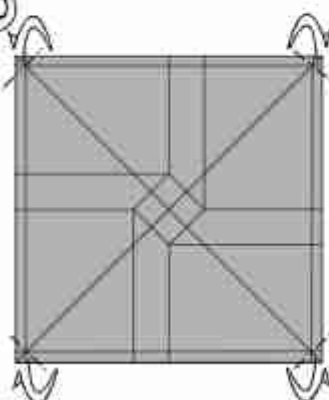

Doblar y desdoblar las cuatro pequeñas esquinas.
Fold and unfold the four little corners.

11

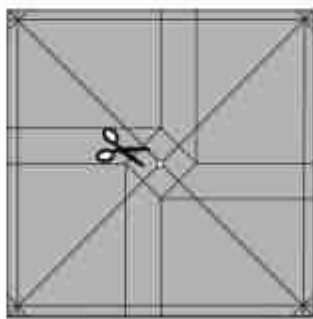

Hacemos un agujero en el centro del papel. Será por donde gire el modelo.
Make a hole in the middle. It will be the rotation point of the model.

12

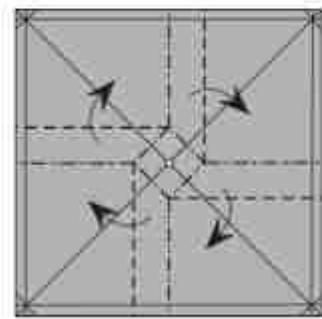

Pliegue twist.
Twist fold.

13

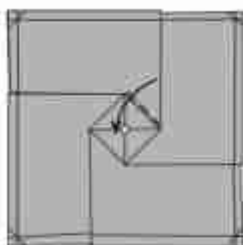

14

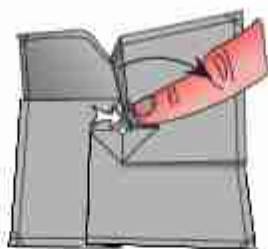

Vista 3D.
3D view.

15

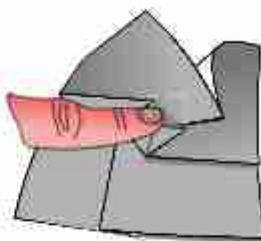

Destoblar.
Unfold.

16

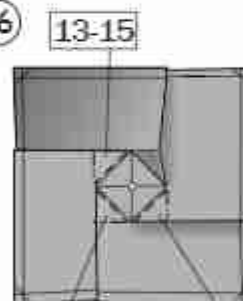

13-15

13-15

17

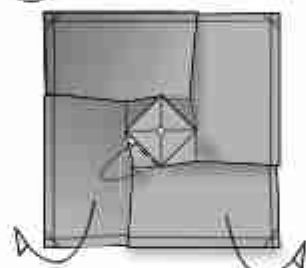

Meter la pestaña bajo el cuadrado pequeño a la vez que se bajan los vértices como si se plegara una rosa (los vértices tienden a subir). En el proceso se curva el papel. Insert the flap under the small square and lower the corners of the paper as if you were folding a rose (the corners of the paper try to go up). It curves as you do it.

18



Desde aquí todos los gráficos son 3D. Repetir el proceso con las otras tres pestañas en sentido contrario a las agujas del reloj. El modelo se cierra. From this step the diagrams are all 3D. Repeat the process with the three remaining flaps on a counter clockwise direction. The model closes.

19



Vista desde abajo. Damos la vuelta al modelo.
View from the bottom.
Turn the model over.

20



Doblar las puntas hacia abajo por las líneas existentes.
Fold down the four little flaps on existing creases.

21

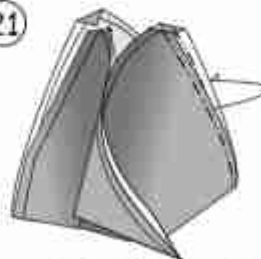

En uno de los laterales doblar por las líneas existentes cogiendo ambas capas. El modelo se cierra por ese lado.
Fold two layers together along existing creases. The model closes.

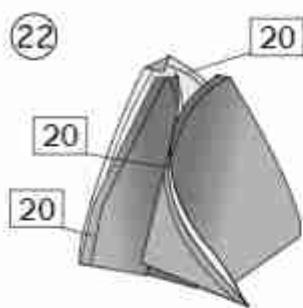

Repetimos en los otros tres lados.
Repeat on the other three sides.



Doblamos un trozo de alambre con una altura similar a la hélice y lo metemos por el agujero inferior.
Fold a wire with the same height as the helix and introduce it by the hole at the bottom.

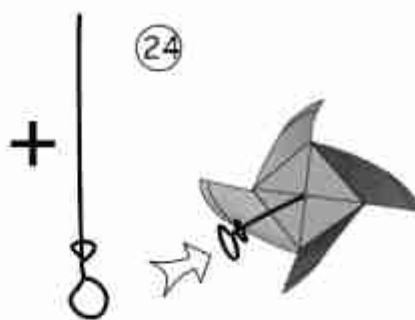

Vista desde abajo.
View from the bottom.



La hélice apoya sobre el alambre.
The helix stands on the wire.

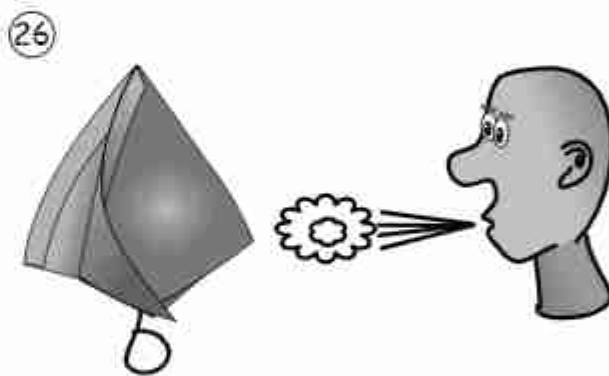

Se puede girar soplando desde el lateral ...
It can be spun by blowing from one side...

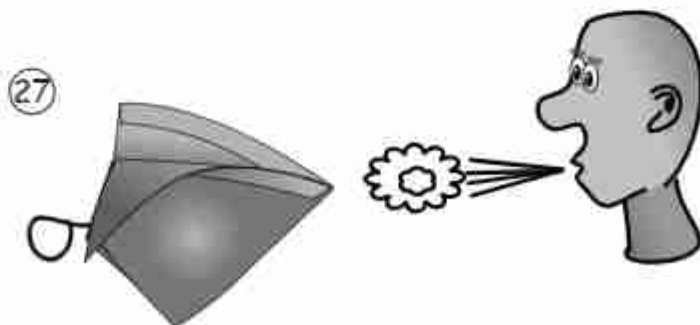

...o desde arriba.
... or from the top.

Dragon

Intermediate

Daniel Bermejo Sánchez

©2017 - Spain

1. Marcar las diagonales.

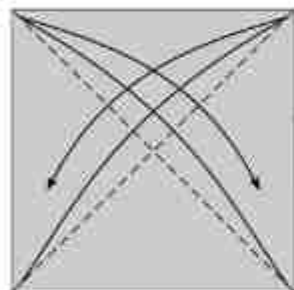

2. Marcar las mitades.

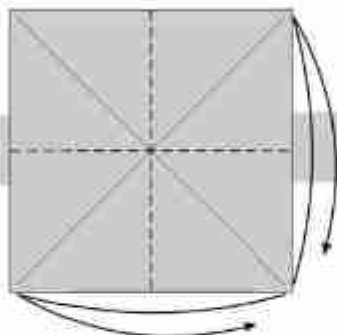

3. Dividir en cuartos y dar la vuelta al papel.

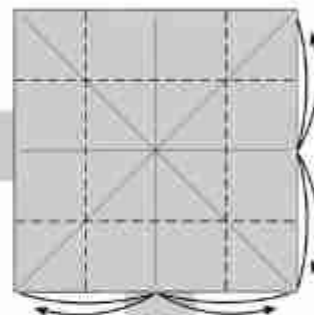

6. Marcar las 4 esquinas.

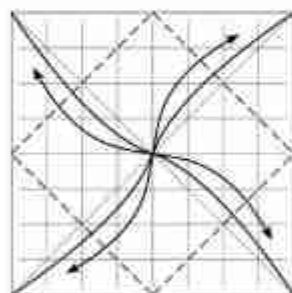

5. Resultado

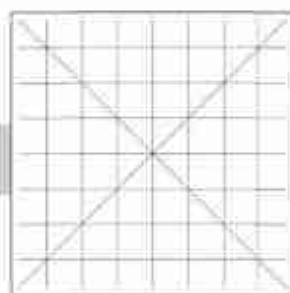

4. Dividir en octavos.

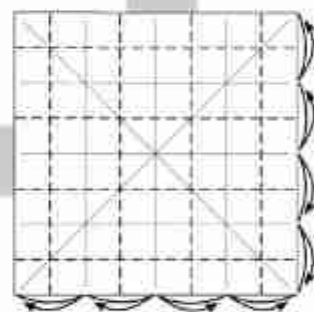

7. Doblar la esquina.

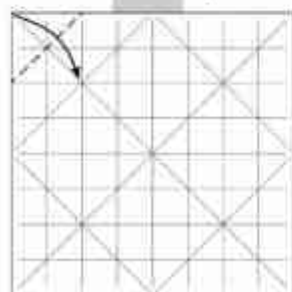

8. Base bomba de agua, cara blanca hacia arriba

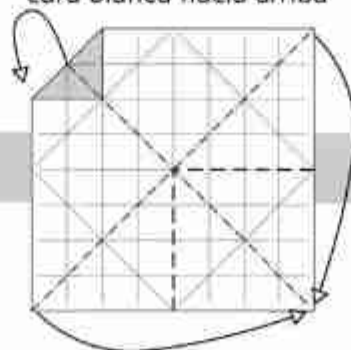

9. Resultado



17. Liberar la punta de color

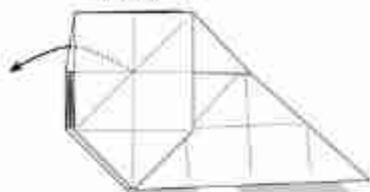

19. Resultado.
El modelo queda bloqueado.

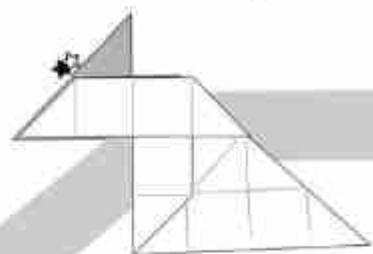

18. Plegar la oreja de conejo por las dos caras a la vez.
Introducir la punta de la estrella negra en el bolso de la estrella blanca.

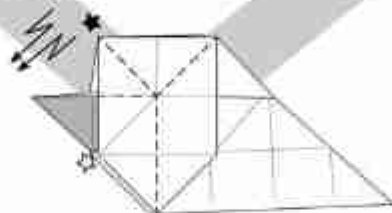

16. Hundido abierto
(Open Sink)

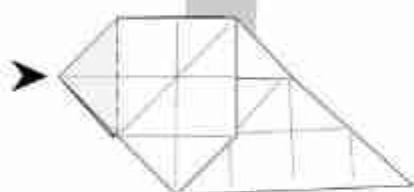

15. *Crimp* simétrico

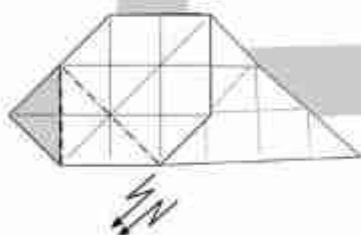

14. Doblar la capa superior.
Repetir detrás.

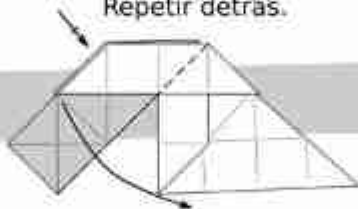

13. Repetir detrás.

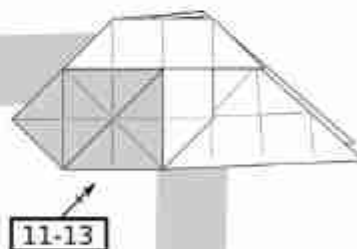

10. Hundido abierto
(Open Sink)

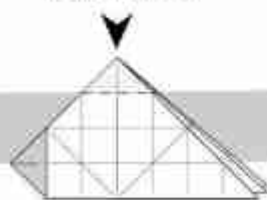

11. Abrir y aplastar la punta.

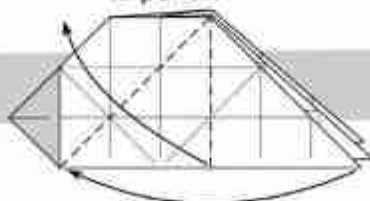

12. Abrir la capa superior.



20. Pliegue invertido

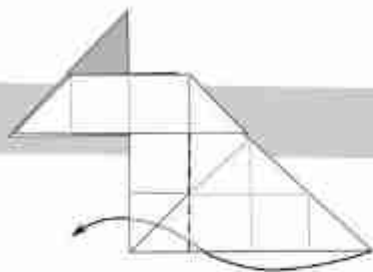

21. Afinar la cola.
Repetir detrás.

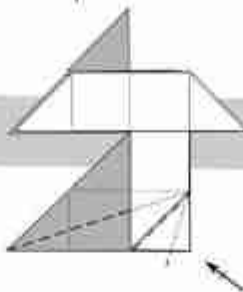

22. Resultado.
Rotación del modelo



25. Resultado

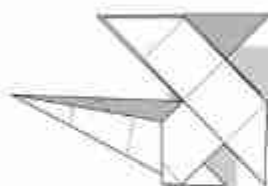

24. Pliegue invertido.
Repetir detrás.

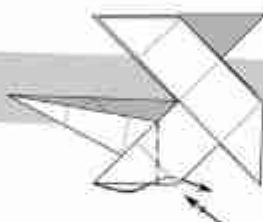

23. Marcar la línea vertical.
Repetir detrás.



26. Marcar por la mitad.
Repetir detrás.



28. Doblar hacia arriba.
Repetir detrás.



27. Hundido abierto.
Repetir detrás.
(Open Sink)



29. Doblar hacia abajo.
Repetir detrás.



33. Modelo finalizado.
Las alas aceptan modificaciones, siempre se puede probar con otro acabado.

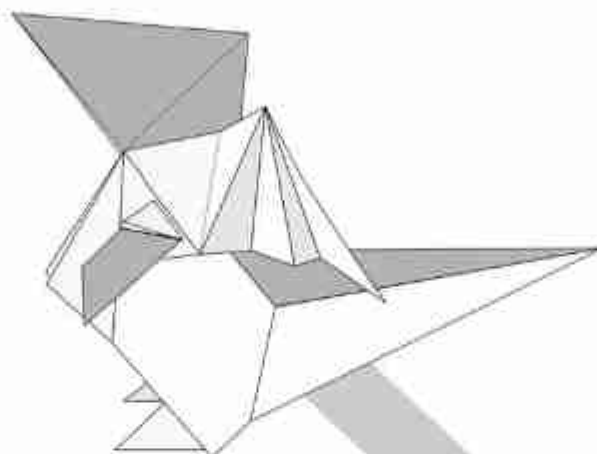

32. Doblar las alas.
Repetir detrás.

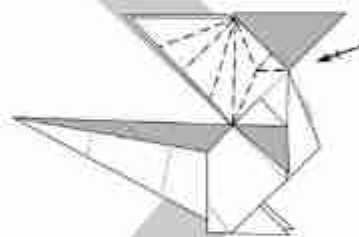

30. Doblar por la mitad.
Repetir detrás.



31. Doblar las 2 primeras capas.
Repetir detrás con la que queda

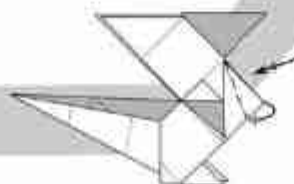

Damavand Volcano

Reza Sarvi
©2018 - Iran

Intermediate

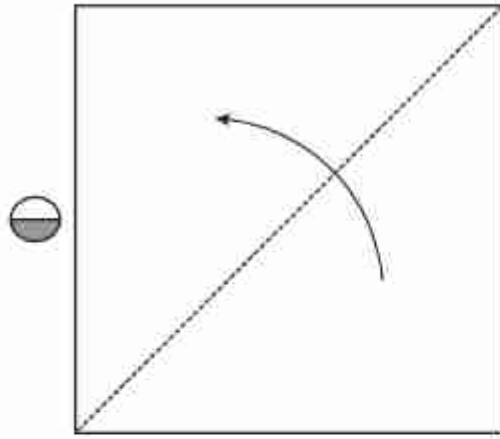

1.

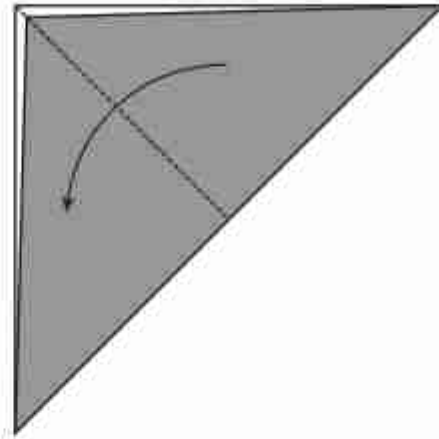

2.

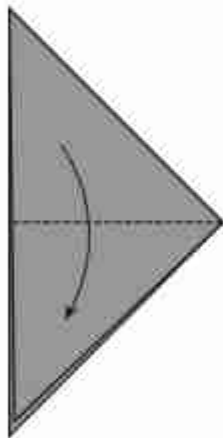

3.

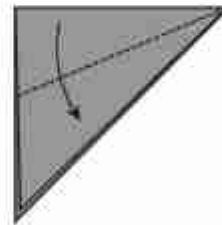

4.

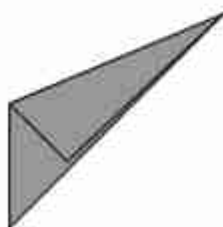

5. Unfold all the model.

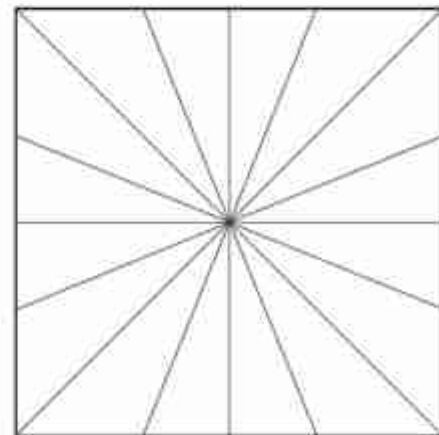

6. The result.

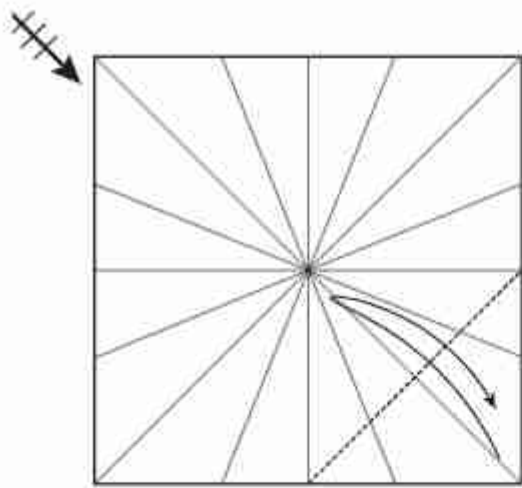

7.

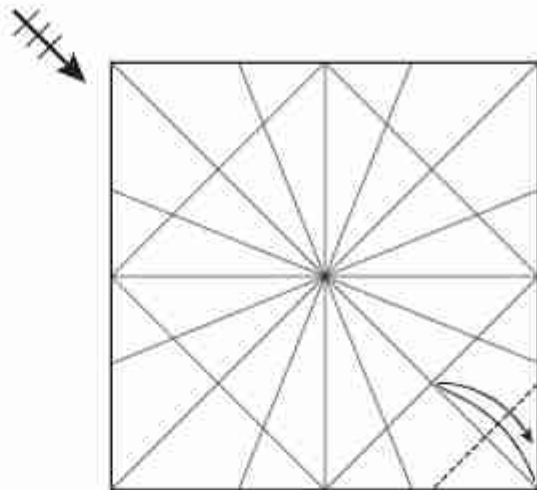

8.

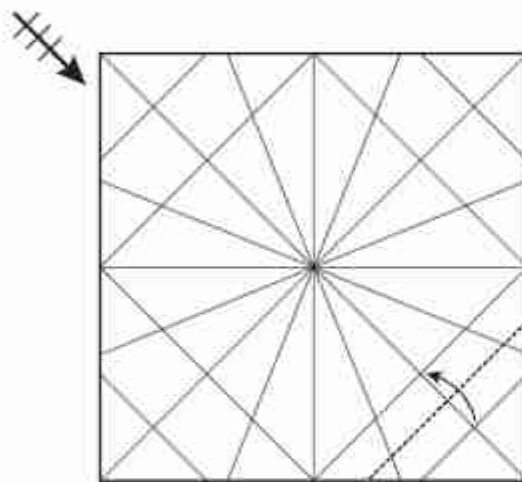

9.

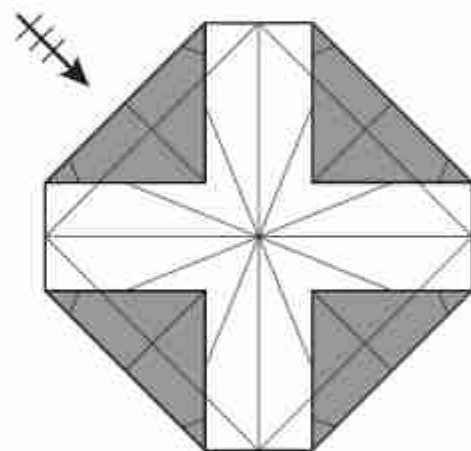

10.

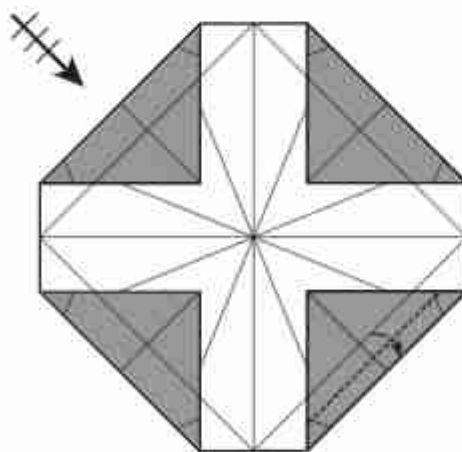

11.

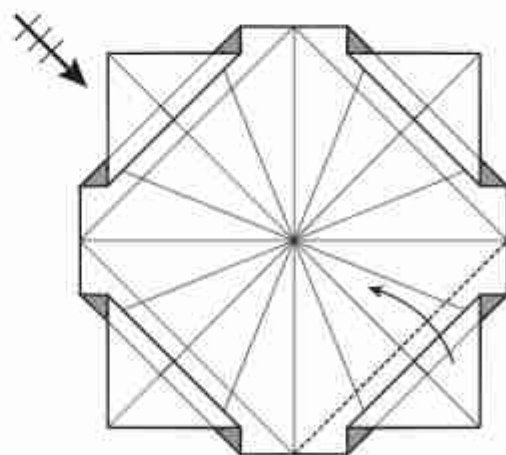

12.

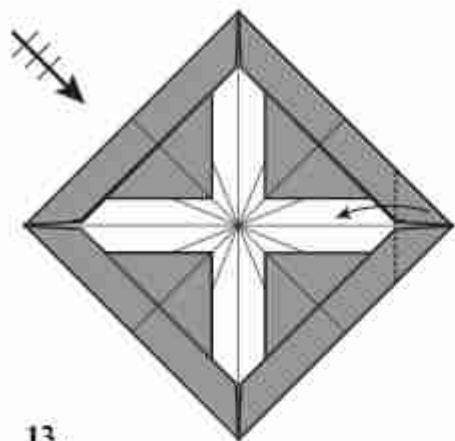

13.

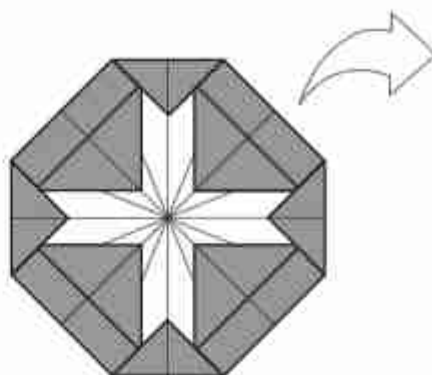

14.

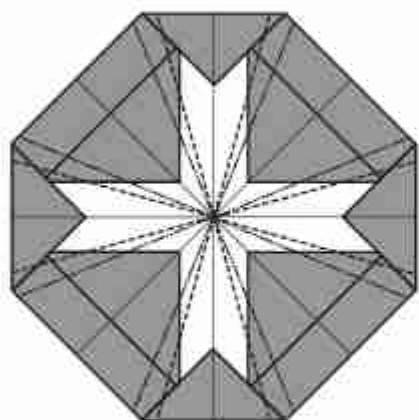

15. Valley and mountain fold along the line.

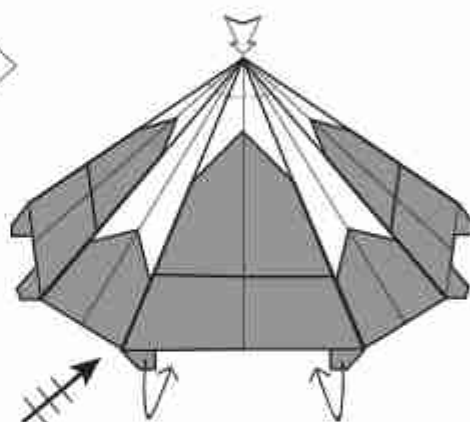

16.

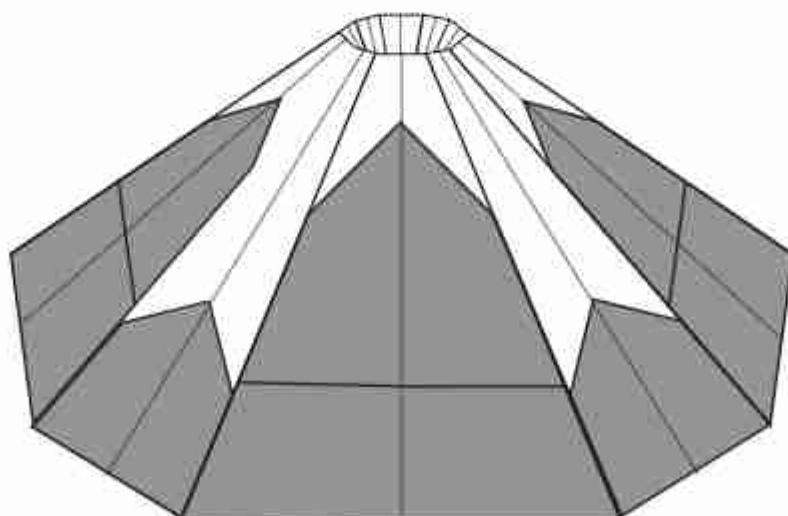

Zombie Hand

Reza Sarvi

©2022 - Iran

Intermediate

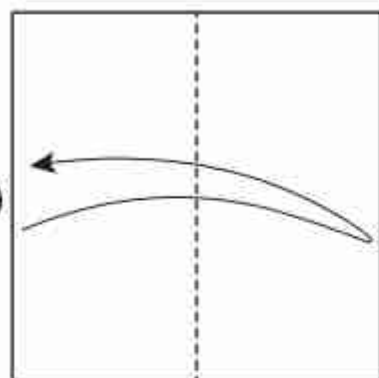

1. Fold and unfold along the line.

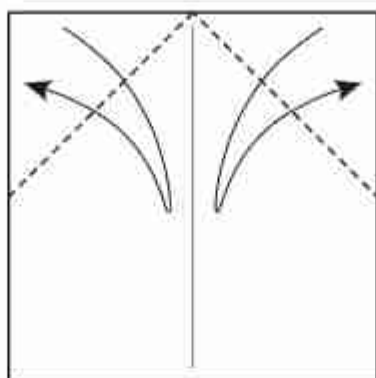

2. Fold and unfold along the lines.
Turn the paper over.

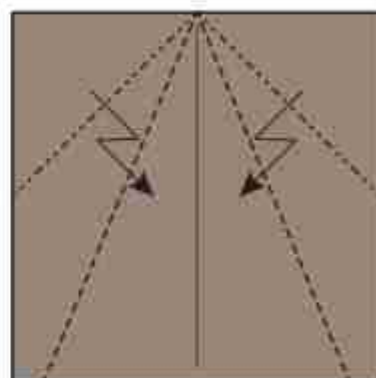

3. Crimp fold along the lines.

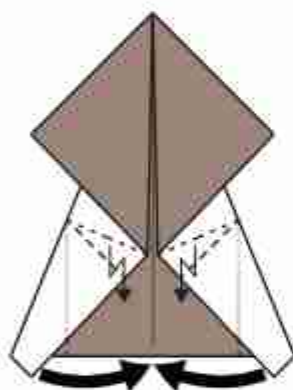

4. Crimp fold along the lines,
so that edges to the center.

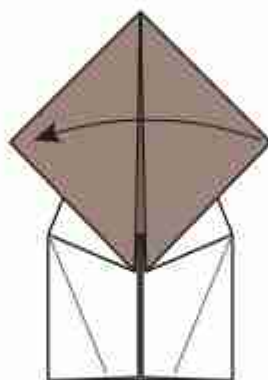

5. Fold the right edge to the left.

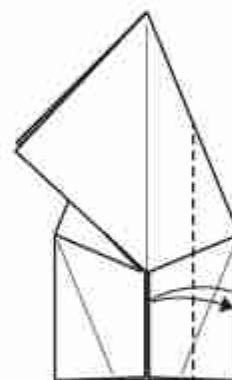

6. Fold and unfold along the line.

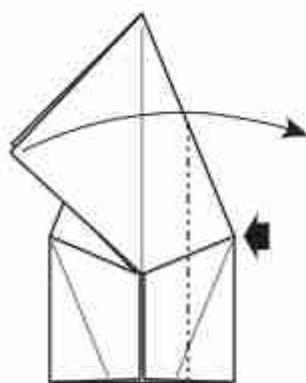

7. Open sink.
Unfold the edge.

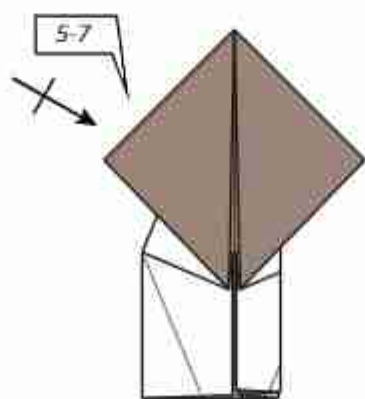

8. Repeat steps 5 to 7 for other side.

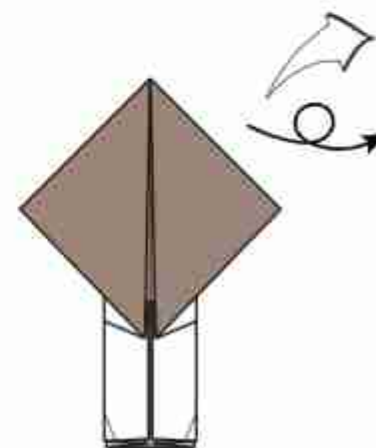

9. Turn the model over.
Enlarge view.

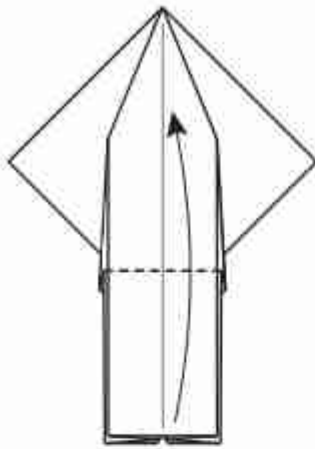

10. Valley fold along the line.

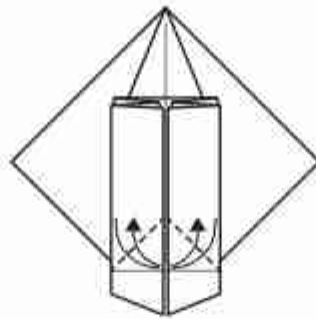

11. Valley fold along the lines.

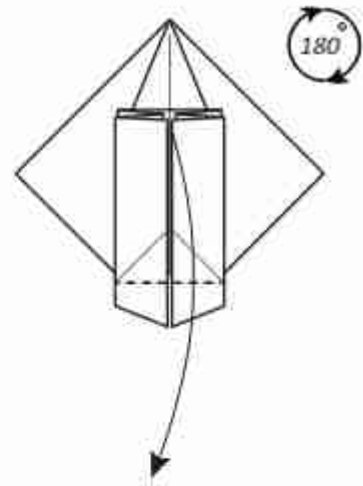

12. Unfold the edge.
Rotate the model by 180 degree.

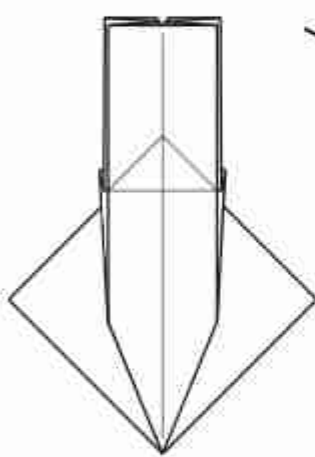

13. Turn the model over.

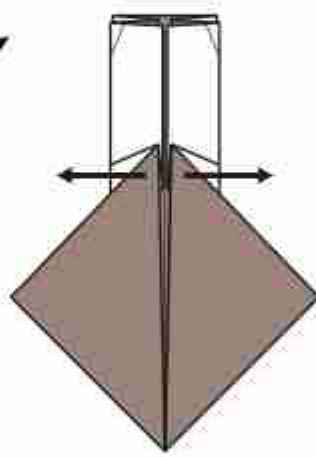

14. Open and separate the
top corners from each other.

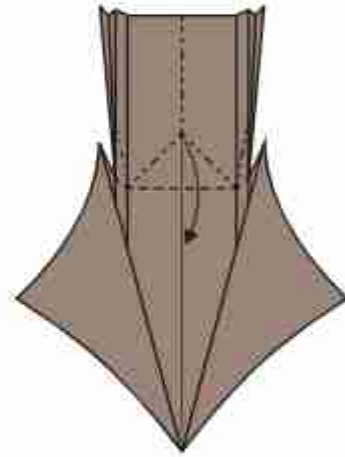

15. Fold down the layers with valley
and mountain fold along the lines.
Close the corners again.

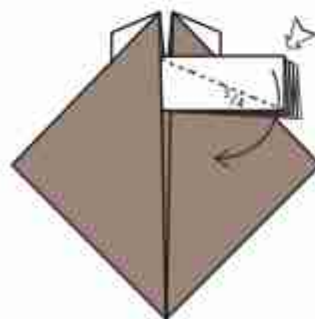

16. Inside reverse fold.

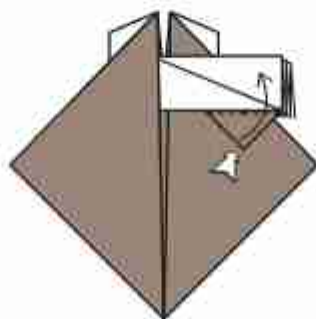

17. Inside reverse fold again.

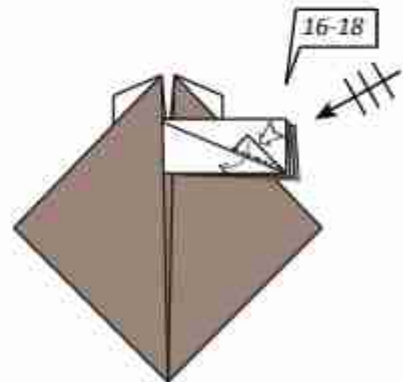

18. Inside reverse fold.
Repeat steps 16 to 18 for
other 3 corners.

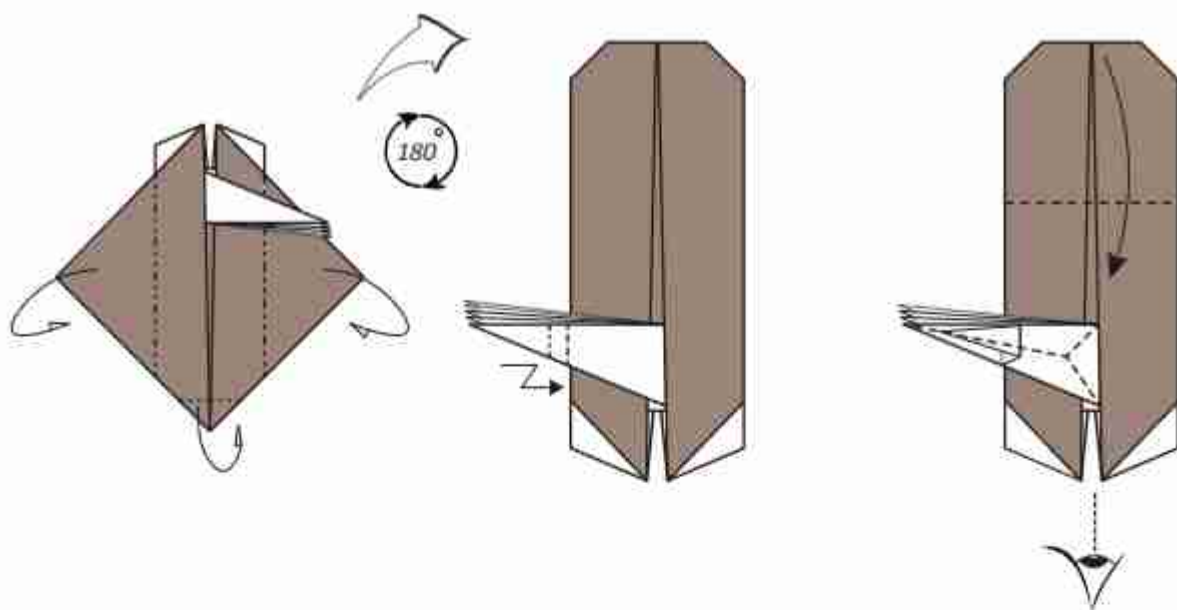

19. Mountain fold along the lines.
 Rotate the model by 180 degree.
 Enlarge view.

20. Crimp fold one layer.

21. Rabbit-ear fold all the white layers.
 Valley fold along the line.
 New viewing angle. Form the fingers.

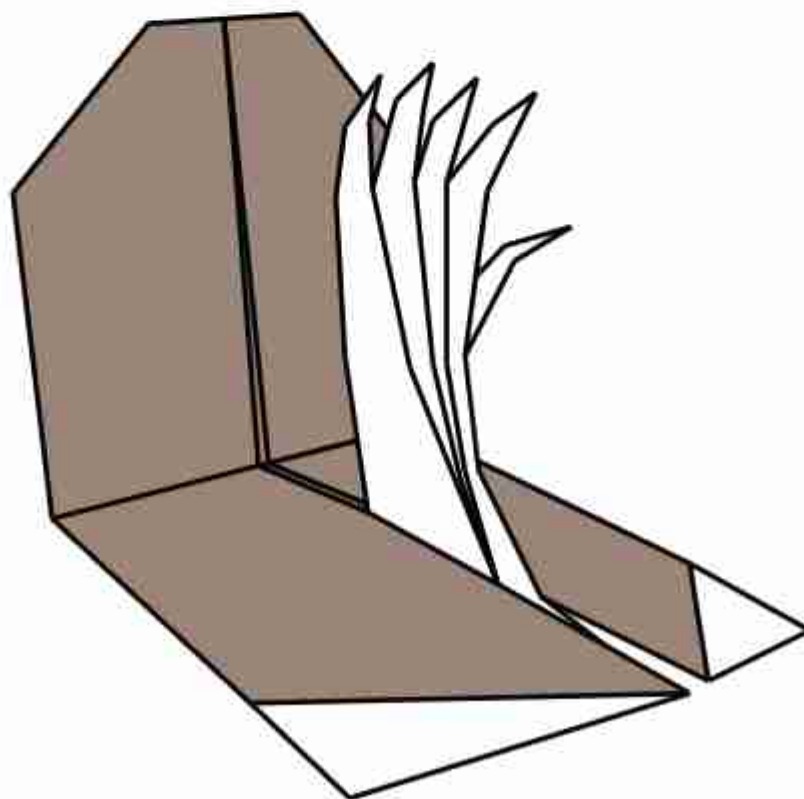

Super Hero

Intermediate

Izzy Seif

Nontanit P. (dgrms.)

©2020 - Israel

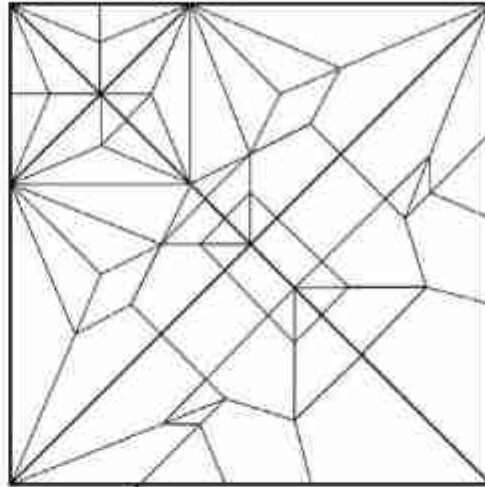

RECOMMENDED PAPER: 20CM. X 20CM

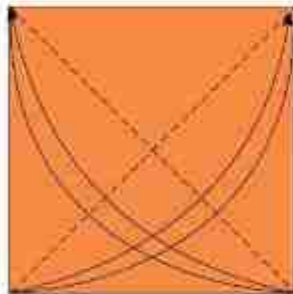

1. Fold and unfold.



2. Fold to create a mark.

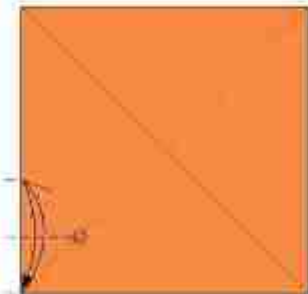

3. Fold to create a mark.



4. Fold to create a mark.



5. Valley fold.

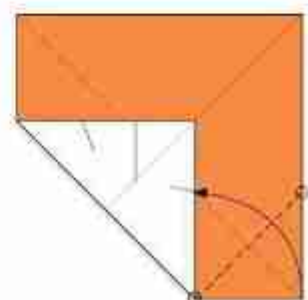

6. Valley fold.

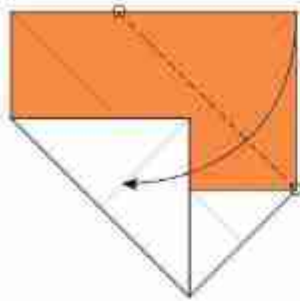

7. Valley fold.

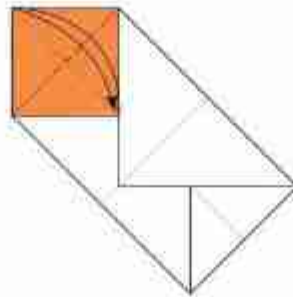

8. Fold to create a mark.

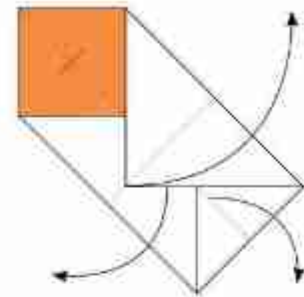

9. Unfold.



10. Fold to create a mark.



11. Valley fold.

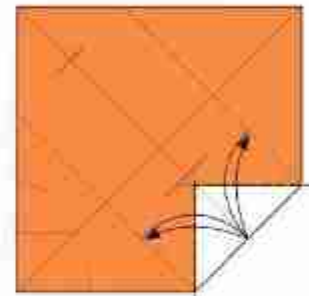

12. Fold and unfold.

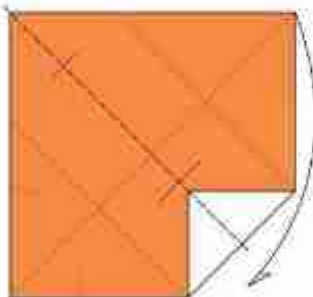

13. Mountain fold

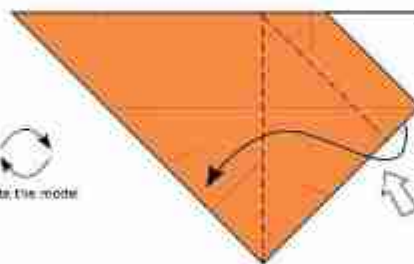

14. Open the flap and squash fold.

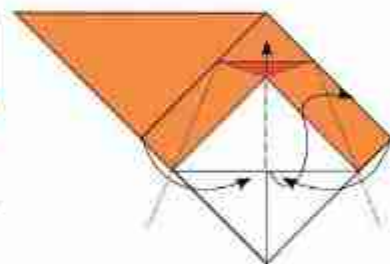

15. Brings both corners in, push up and squash fold the flap.

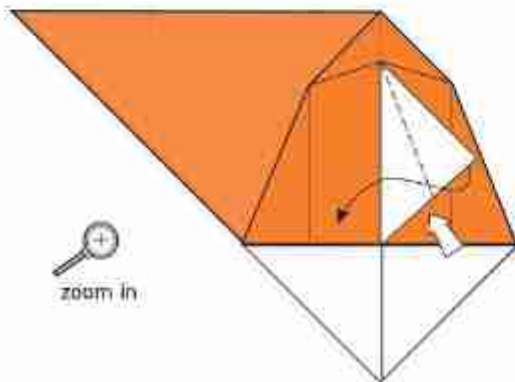

16. Squash fold

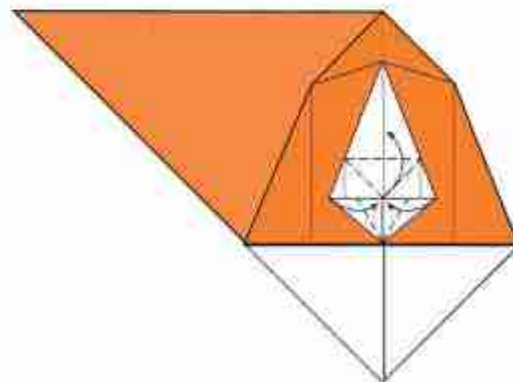

17. Petal folds.

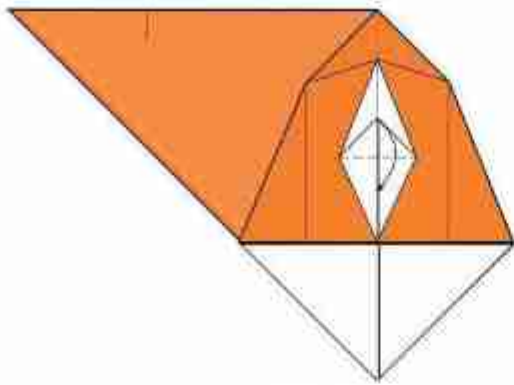

18. Fold the flap down.

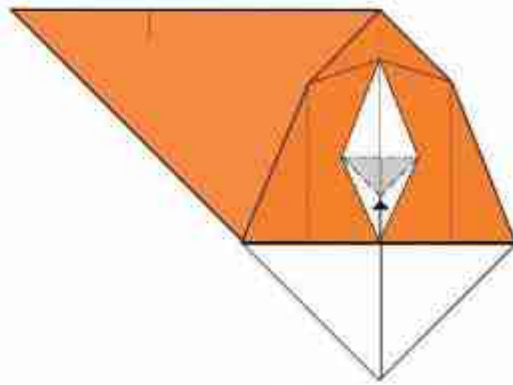

19. Open sink.

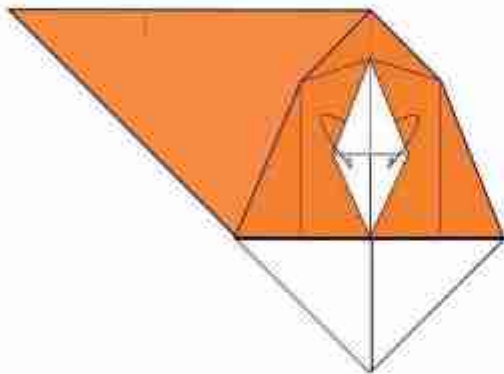

20. Unwrap the hidden layer.

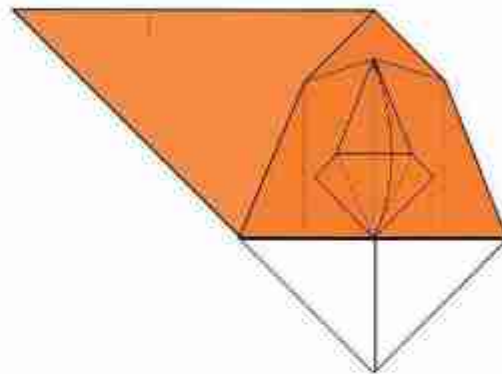

21. Petal folds.

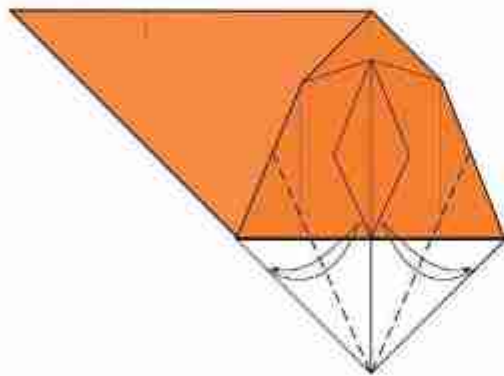

22. Fold and unfold.

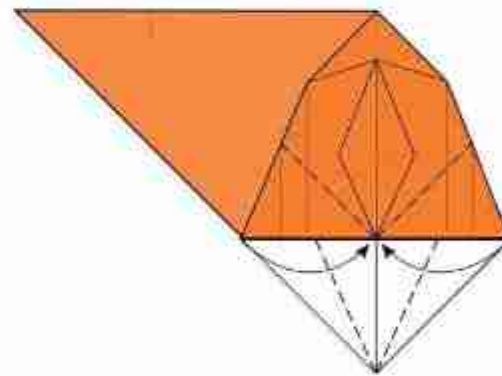

23. Fold in the corners.

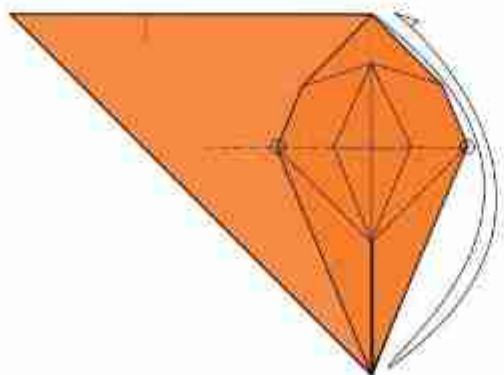

24. Fold and unfold.

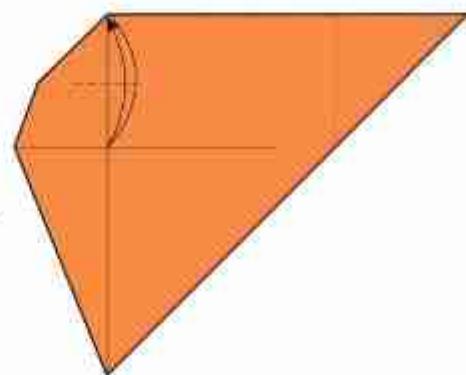

25. Fold and unfold.

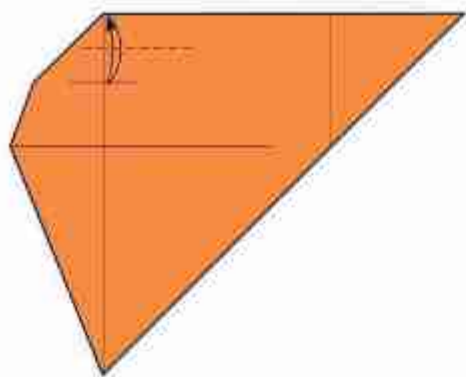

26. Fold and unfold.

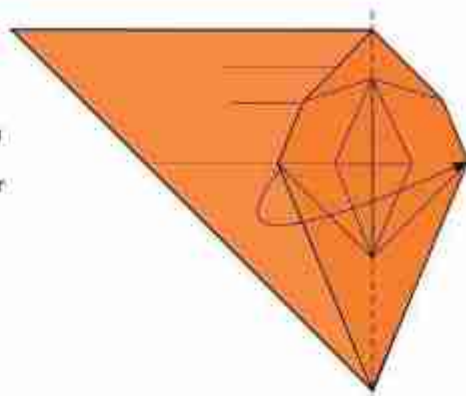

27. Fold all the layers to right.



turn over

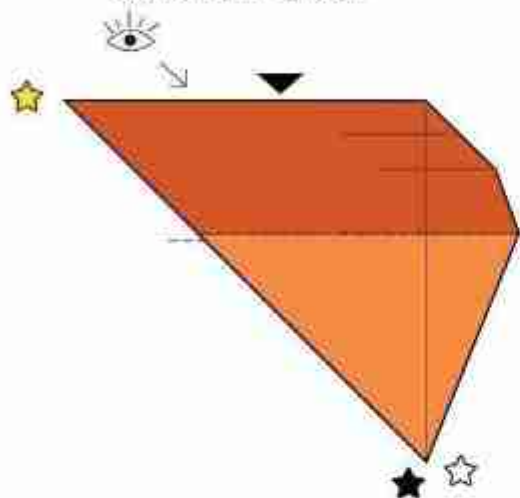

28. Open sink.

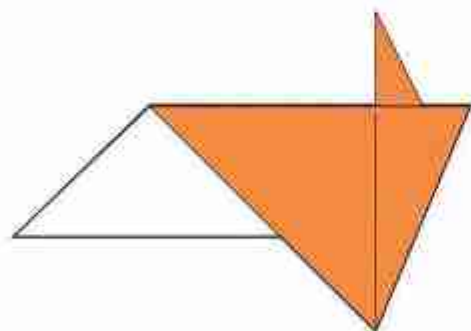
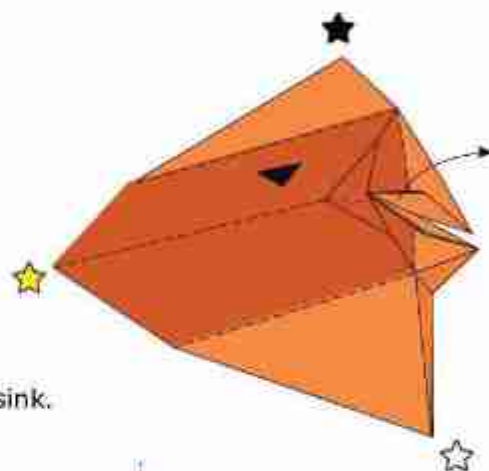

29. Turn the model over.

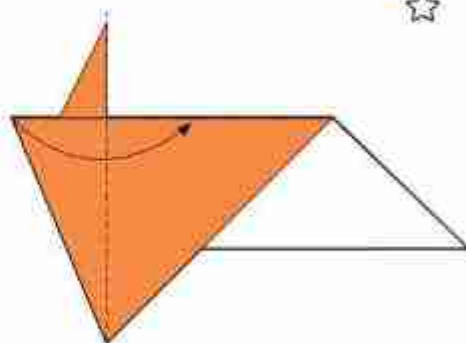

30. Valley fold.

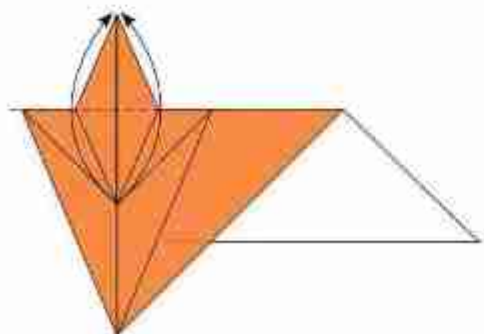

31. Valley fold.

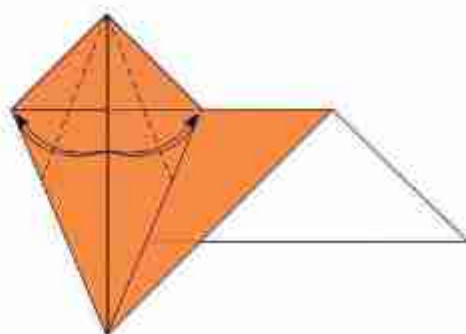

32. Fold and unfold.

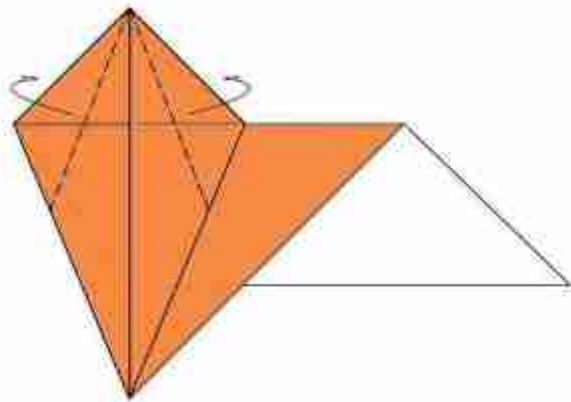

33. Reverse folds, make sure the flaps are free from the layers.

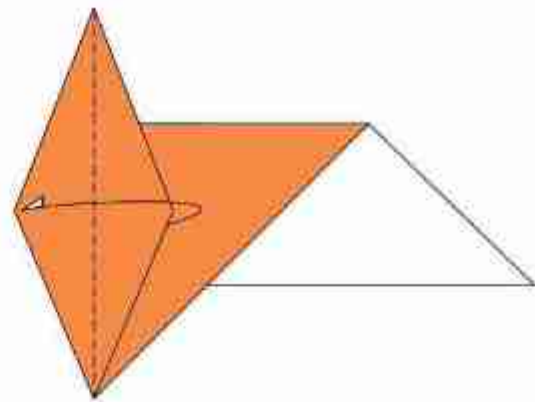

34. Valley fold.

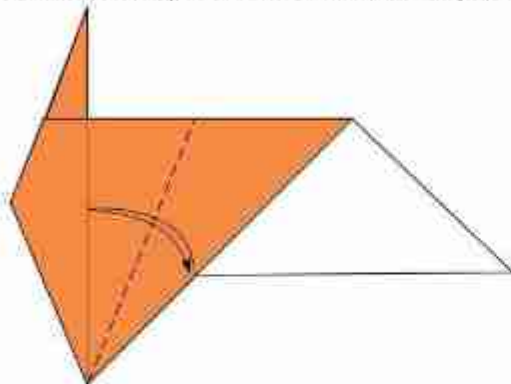

35. Fold and unfold.

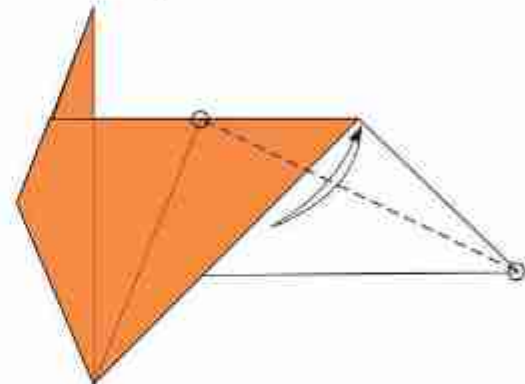

36. Fold and unfold.

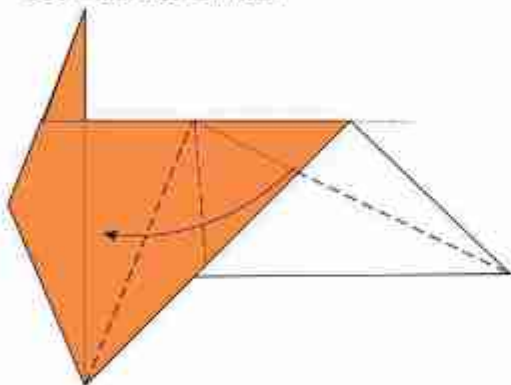

37. Squash fold.

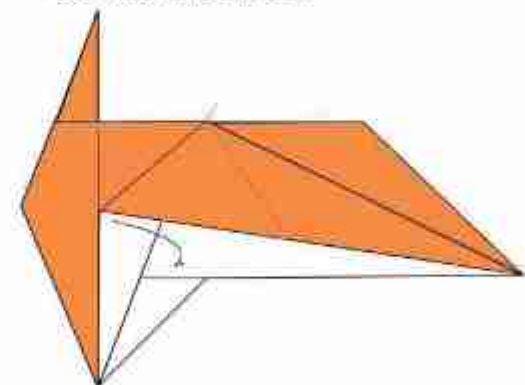

38. Tug the flap.

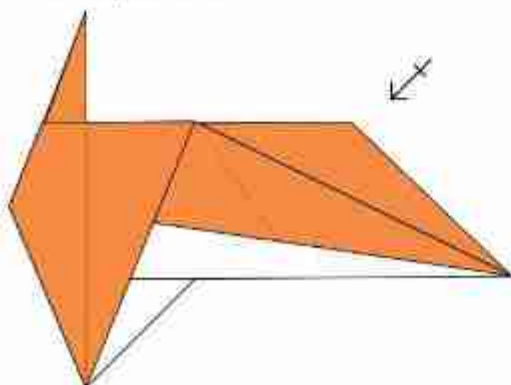

39. Repeat steps 35 -38.

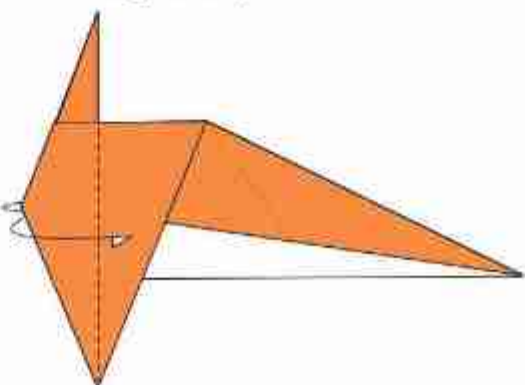

40. Valley fold on both side.

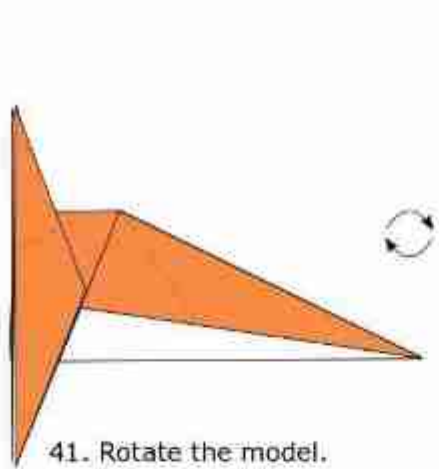

41. Rotate the model.



42. Valley fold.

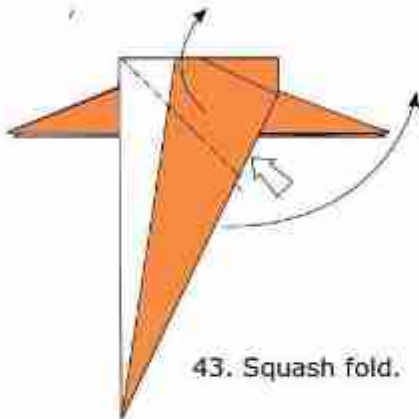

43. Squash fold.

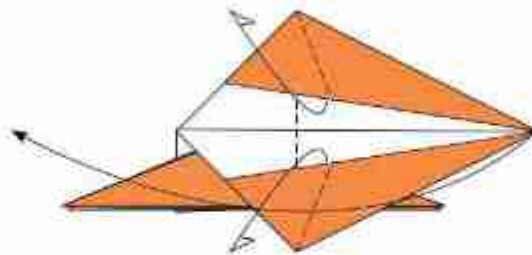

44. Squash fold.

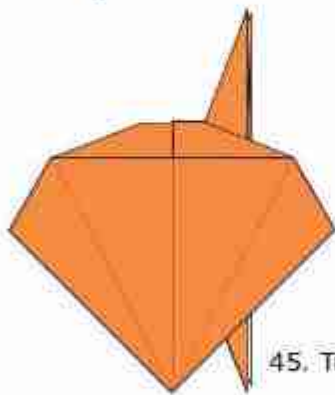

45. Turn the model over.

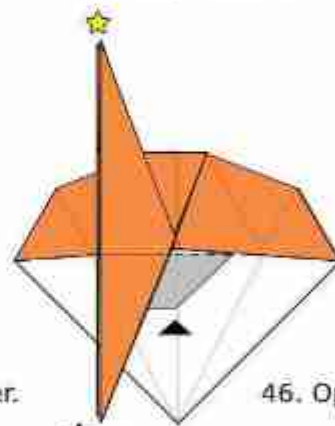

46. Open sink.

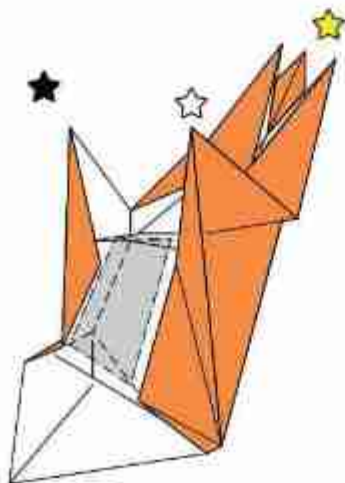

47. Valley fold.

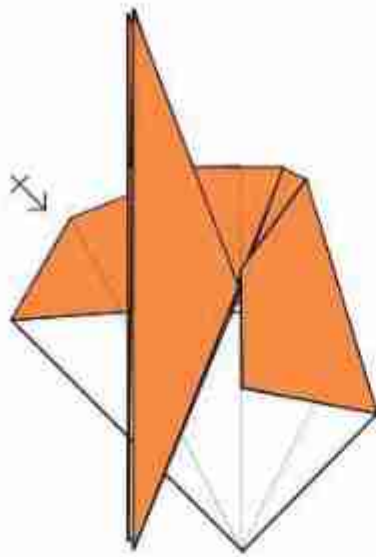

48. Repeat step 47.



49. Valley fold the flap under.

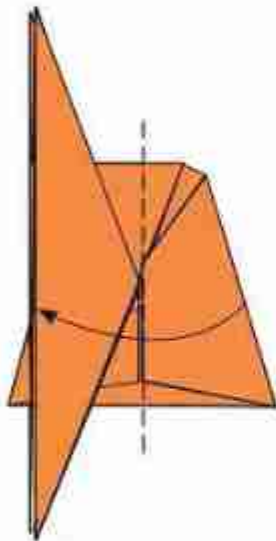

50. Valley fold.

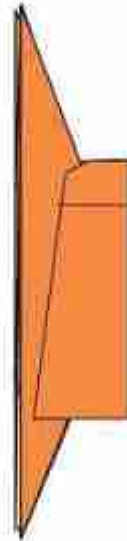

51. Turn the model over.

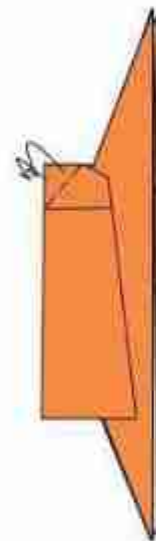

52. Tug in the flaps.

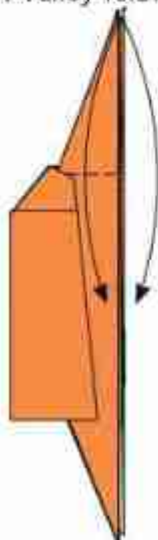

53. Fold the flaps down.

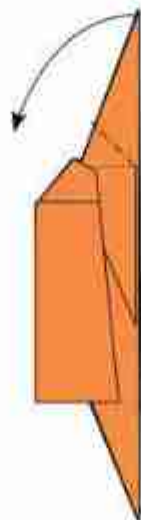

54. Inside reverse fold.

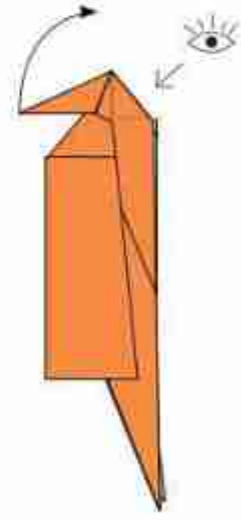

55. Inside reverse fold.



56. Gently spread the layers .



57. Pinch fold the tip up .



58. Pinch the tip back and shape the arms and legs.

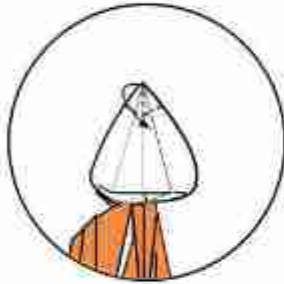

Alternative shaping .
57. Pinch fold the tip in.



58. Valley fold to lock the flap.



59. Hairless hood.

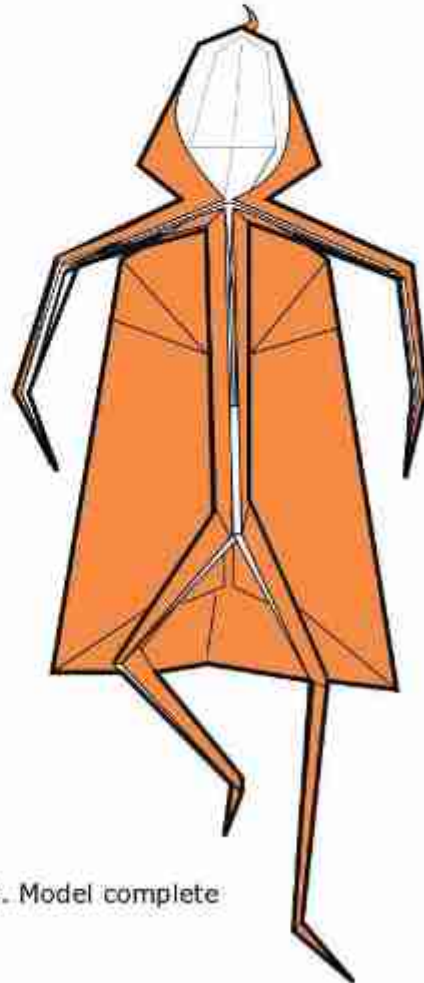

59. Model complete

Bird of Peace Pop-up Card

Jeremy Shafer

©1999 - USA

Low Intermediate

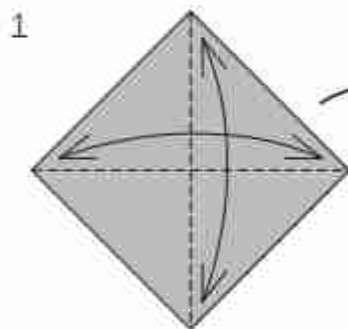

Colored side up.
Valley-fold and unfold.
Turn over.

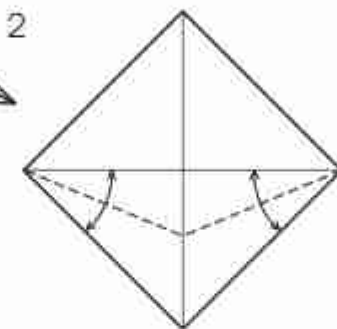

Valley-fold and unfold.

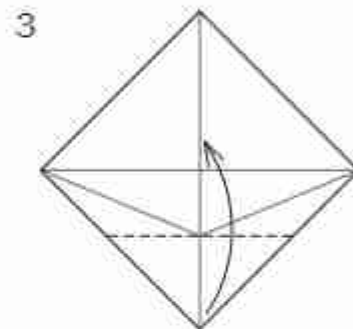

Valley-fold.

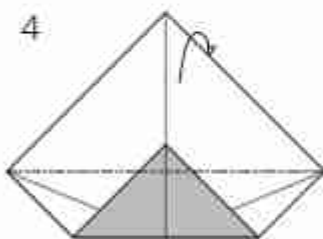

Mountain-fold the top
half behind.

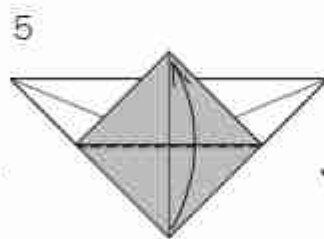

Valley-fold.

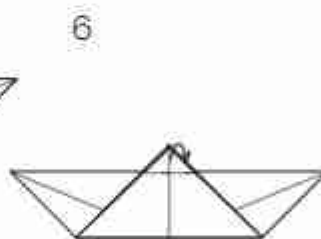

Mountain-fold the front
corner inside, lining the fold
up with the rear edge.

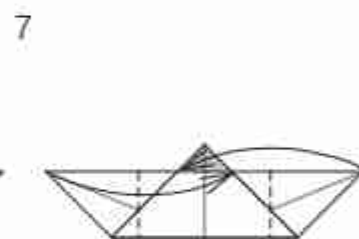

Valley-fold.

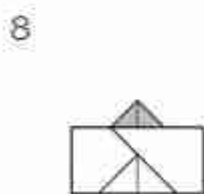

Our favorite step...
completely unfold
the model!

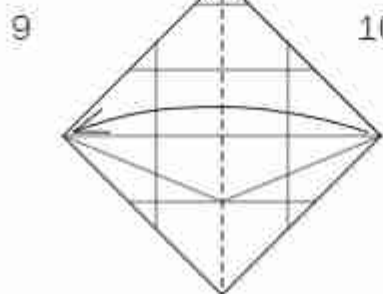

White side up,
valley-fold in half.

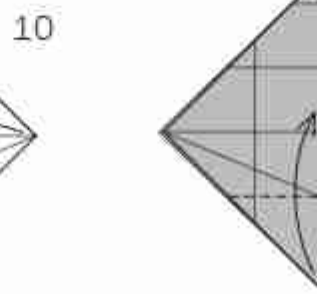

Valley-fold the corner up
along the existing
crease.

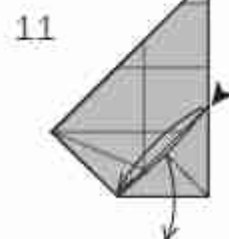

Squash!

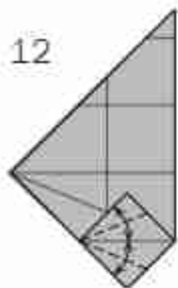

12

Valley-fold and unfold.

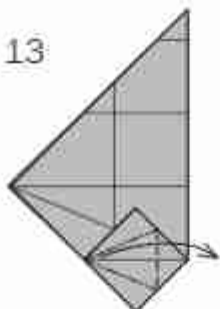

13

Petal-fold.

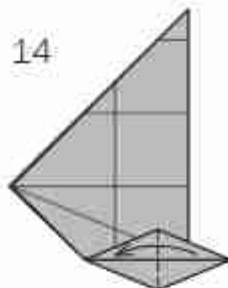

14

Valley-fold.

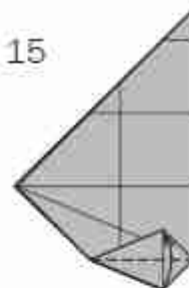

15

Valley-fold.

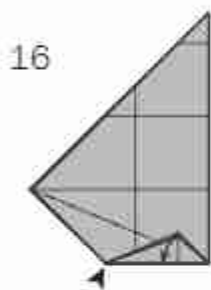

16

Reverse-fold (i.e. push the point in) along existing creases.

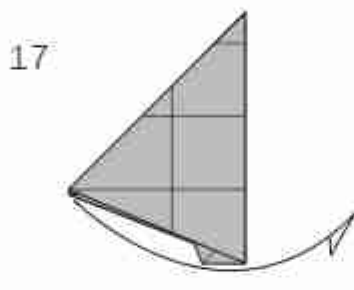

17

Swing the back flap out from behind. The back of the model won't lie flat... but it's the back... so, ha ha, I don't need to draw it yet.

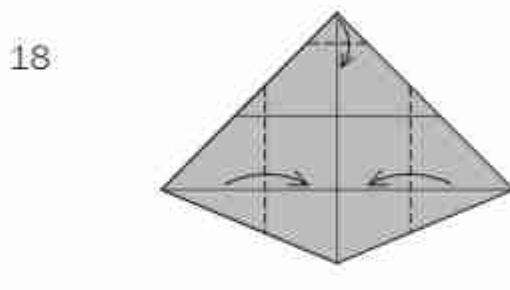

18

Make valley folds along existing creases.

OPTIONAL

18a

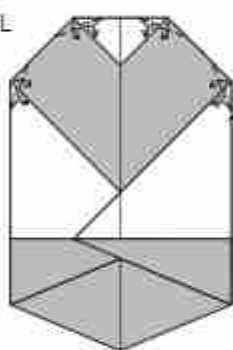

If you would like a heart concealed in your card, make swivel folds at the corners. But the card will look slightly nicer if you skip this option.

18b

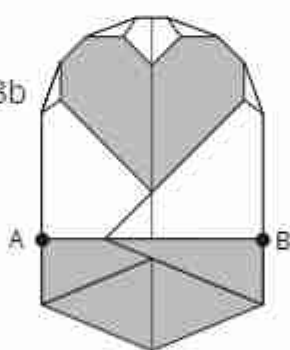

Right now this looks like a lovely tombstone (from the back too), or if you valley-fold between A and B, it's a love seat.

19

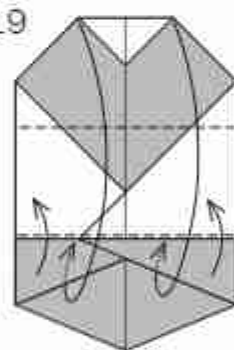

Valley-fold the top down and the bottom up on the existing creases. As you do this slip the top edge into the pocket. Rotate the model 180°.

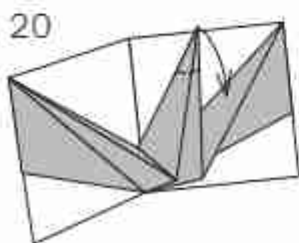

20

Reverse fold the head. It's a Bird! It's a Plane! It's...

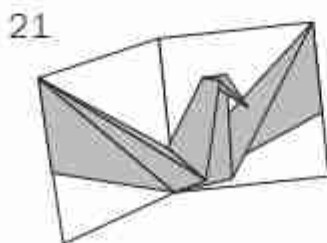

21

...Just a bird. Indeed, the Bird of Peace has been spotted...

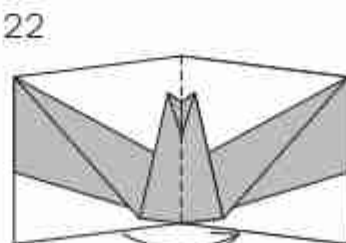

22

...And is now looking straight at you. Close the card.

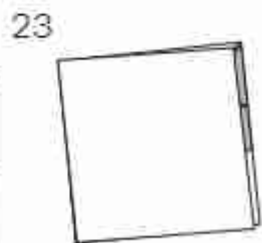

23

The Bird of Peace card is enclosed for safe keeping.

Heart Hand Crane

Jeremy Shafer

©2003 - USA

Low Intermediate

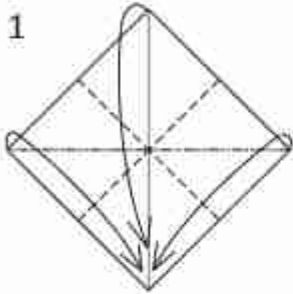

1
Folded out of pink/white paper you can call the fifth finger a "pinky," but I think overall the model is more convincing folded from paper that is the same color on both sides. Begin by folding a Square Base.

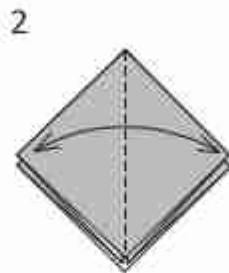

2
Valley-fold and unfold through all layers.

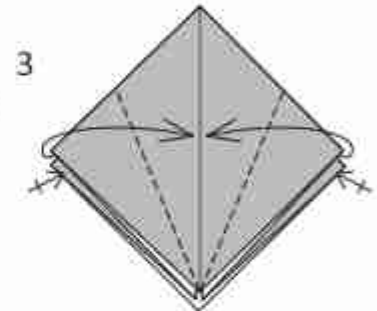

3
Valley-fold. Repeat behind.

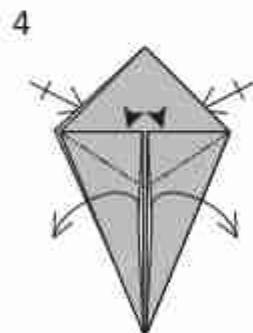

4
Squash. Repeat behind.

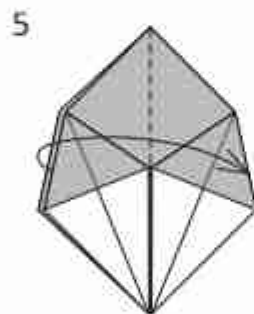

5
Valley-fold the left front flap rightward.

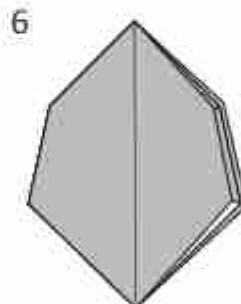

6
Turn over.

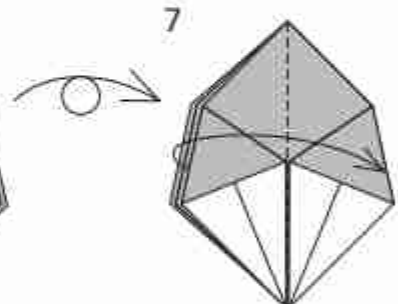

7
Valley-fold the left front flap rightward.

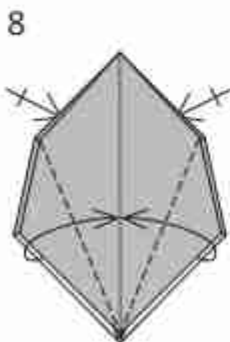

8
Valley-fold. Repeat behind.

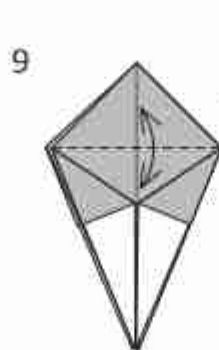

9
Valley-fold and unfold. Turn over.

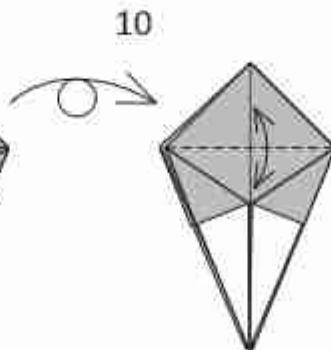

10
Valley-fold and unfold.

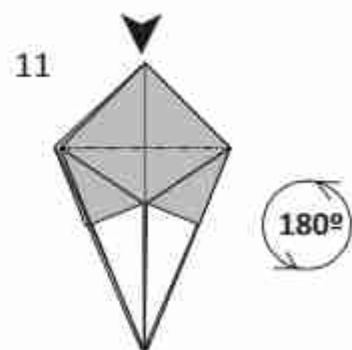

11
Sink.

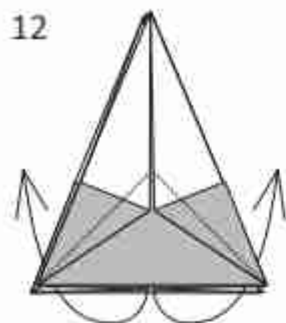

Reverse-fold the two interior flaps.

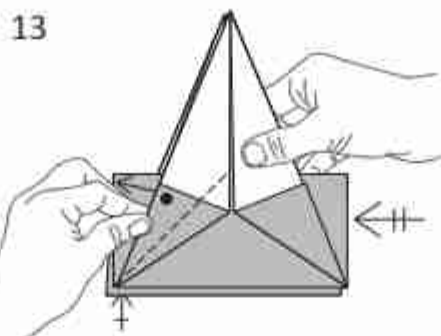

Pull the folded edge leftward so that it is even with the leftside of the model. Watch the black dot. Repeat on the right. Repeat behind.

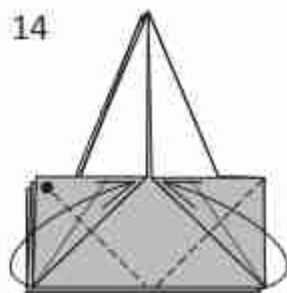

Valley-fold the two front flaps.

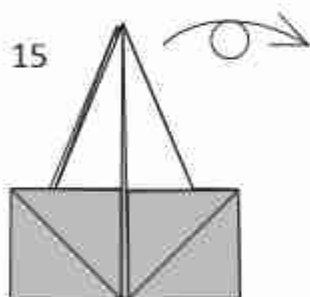

Turn over.

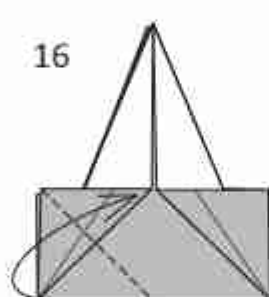

Valley-fold the left flap.

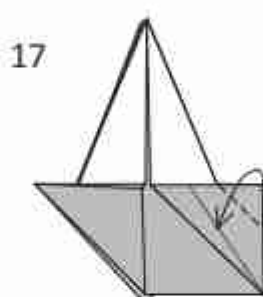

Valley-fold through all layers at a 45° angle.

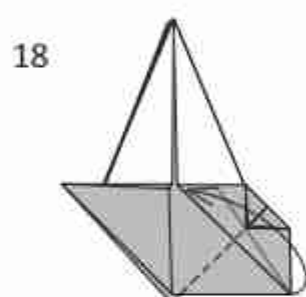

Valley-fold.

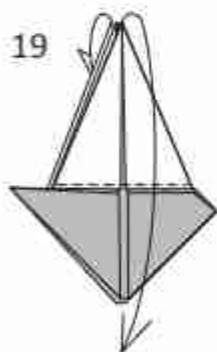

Valley-fold one flap down. Repeat behind.

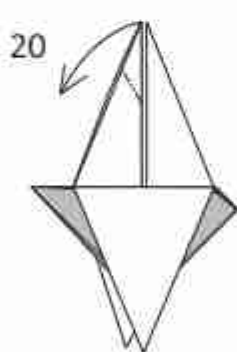

Reverse-fold the left flap.

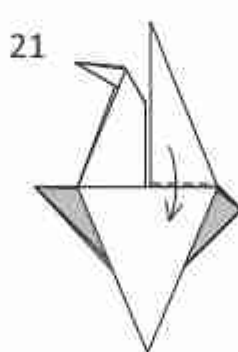

Valley-fold the right flap.

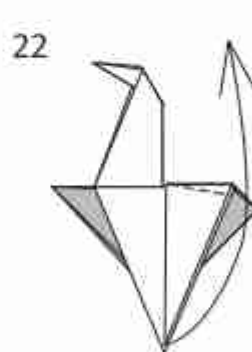

Valley-fold the same flap.

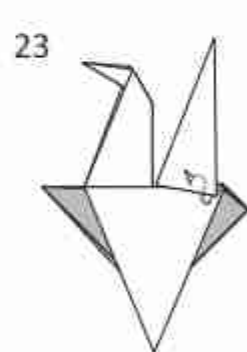

Hide the pleat beneath the front layer.

Thoughts Behind the Folds

In March of 2003 I was a contestant on the origami episode of TV Champion, a Japanese reality game show. The first round of the competition was to fold a model that completely transforms and changes color in one move. A month after the competition, with transformation still on my mind, I came up with this model. It started out as a folding exercise to make a pop-up crane card. Then I asked myself what else did the folded-up model look like. I saw a four-fingered hand. The heart came out of an attempt to make the fifth finger. **Challenge:** Can you come up with a story to tie together a Heart, Hand, and Crane?

24

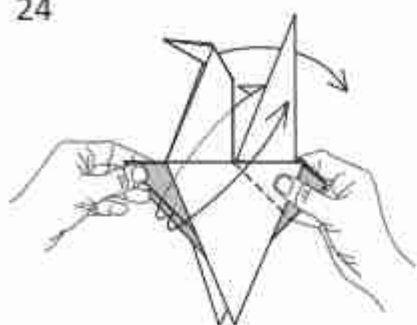

Outside-reverse fold the whole left half of the model, letting the head swing behind the tail.

25

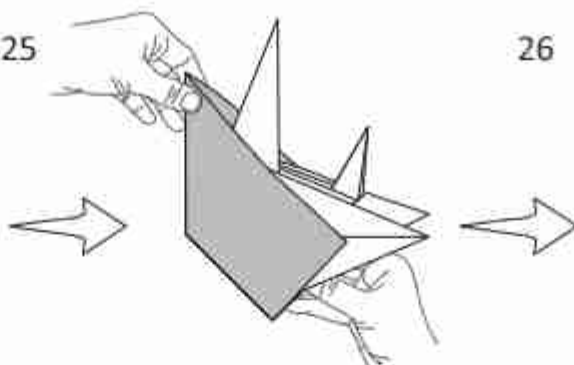

Like this. Imagine tearing off the front flap. The next step is what it would look like. But don't really tear the paper! Just imagine.

26

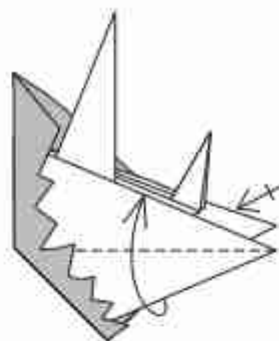

Valley-fold the white flap. Repeat behind.

27

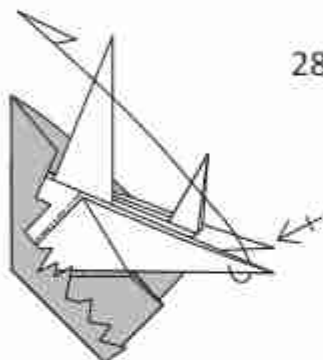

Mountain-fold the flap upward. Repeat behind.

28

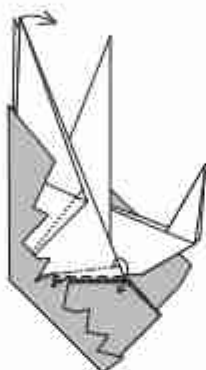

Rotate the frontmost white flap about 10° clockwise.

29

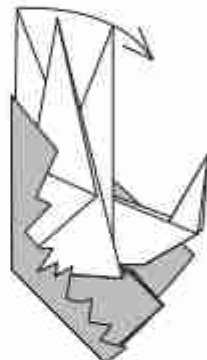

Rotate the rearmost white flap about 35° clockwise. Stop imagining that the front flap is torn off.

30

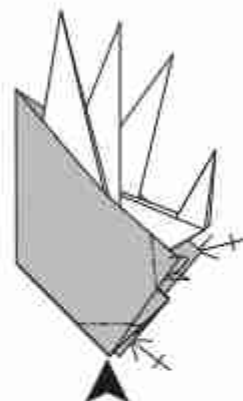

Reverse-fold below. Mountain fold on the right. Repeat behind.

31

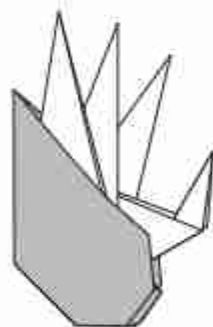

The hand is ready for transformation.

32



Show the Heart to the audience and say, "Now let's all give this model a big hand!" {Rotate the model 90°.}

90°

33

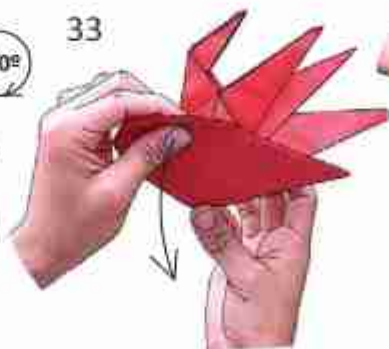

"Thanks for giving the model such a big hand! Except for you Sir. Why didn't you clap? What, do you think this model is for the birds?" {Holding as shown, swing the flap down, letting the head and tail swing into place.}

34

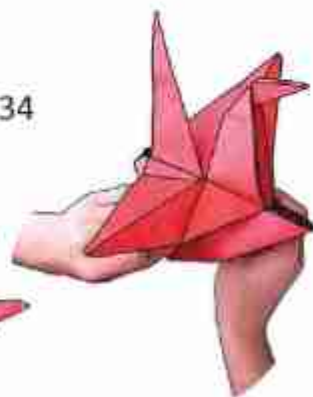

"Well, You're Right. Ok, let's give this bird a big hand." {Go back to step 33.} "Thank you" {Wave with the hand.} "I love you all" {Go back to step 32.}

Worm in an Apple

Jeremy Shafer

©2022 - USA

Intermediate

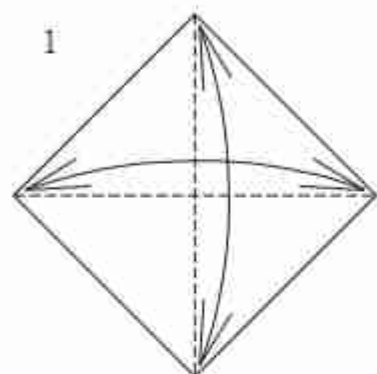

White side up, valley-fold in half diagonally and unfold in both directions.

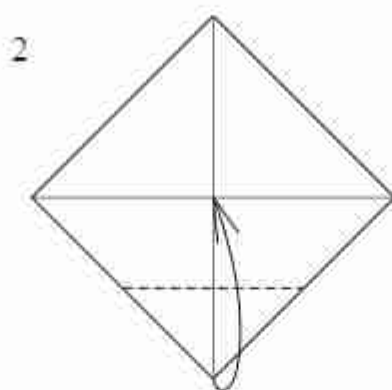

Valley-fold.

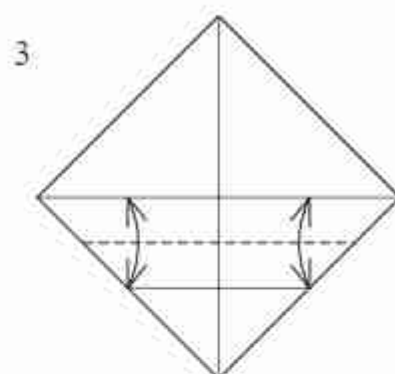

Valley-fold crease-to-crease.

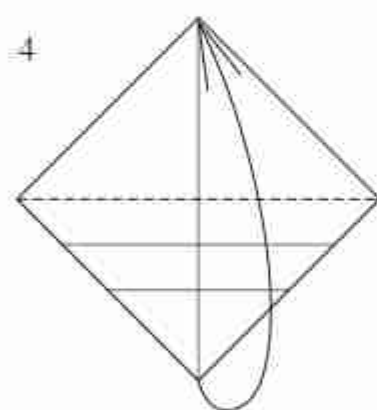

Valley-fold in half.

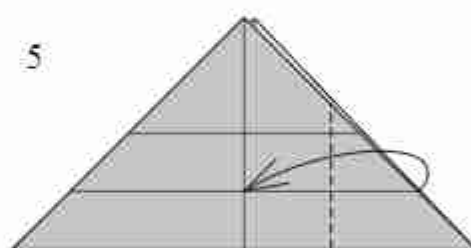

Valley-fold the edge to the intersection of the creases.

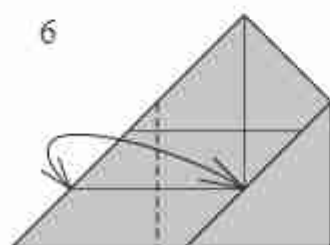

Valley-fold and unfold.

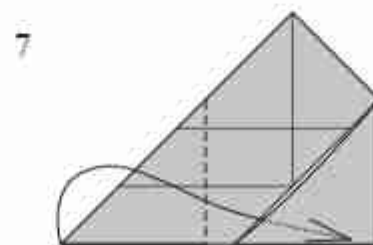

Valley-fold, inserting the corner into the pocket.

White Stem Variation

8a



Valley-fold a single layer edge-to-crease.

8b

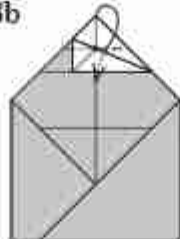

Valley-fold on the black dot behind the front layer.

8c



Unfold the flap.

8d



Continue to step 9.

8

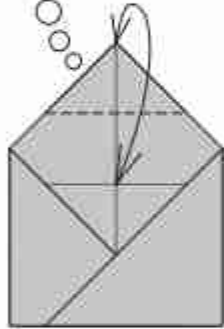

Valley-fold and unfold.

9

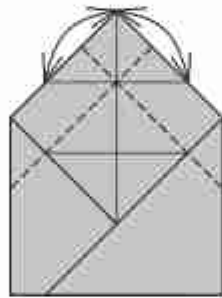

Valley-fold and unfold.

10

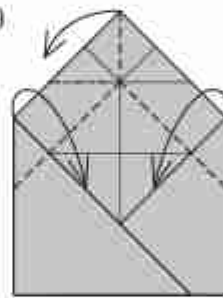

Rabbit-ear.

11

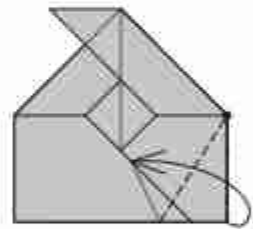

Valley-fold on the black dot so that the corner touches the edge.

12

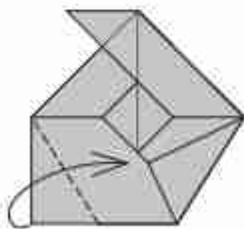

Valley-fold so that the left and right sides are even.

13

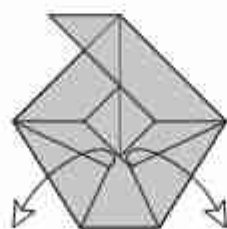

Unfold.

14

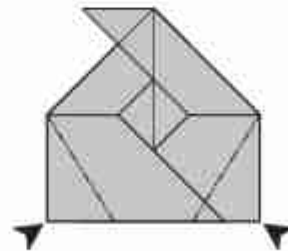

Reverse-fold.

15

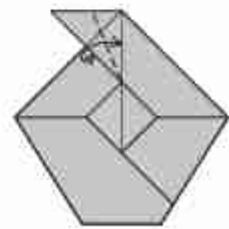

Valley-fold and unfold.

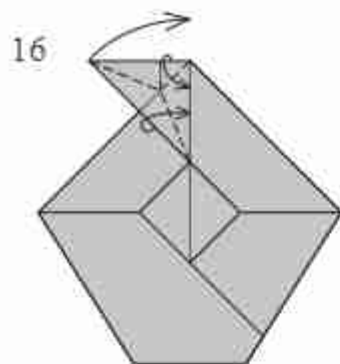

Rabbit-ear.

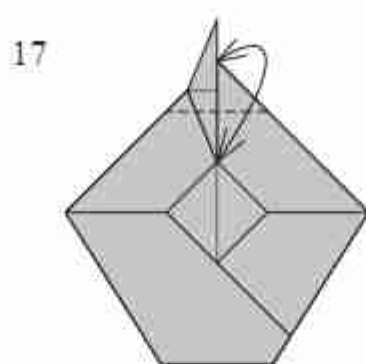

Valley-fold and unfold.

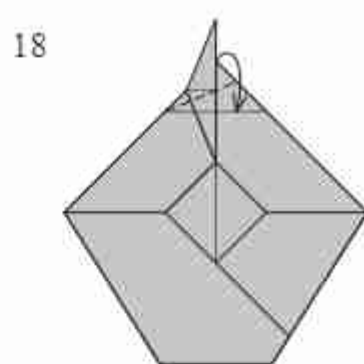

Valley-fold on all layers.

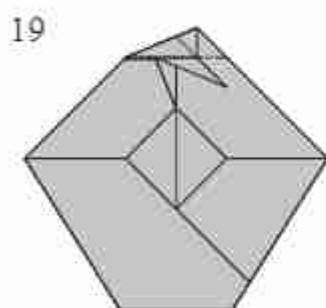

Mountain-fold, letting the front flap swing upward.

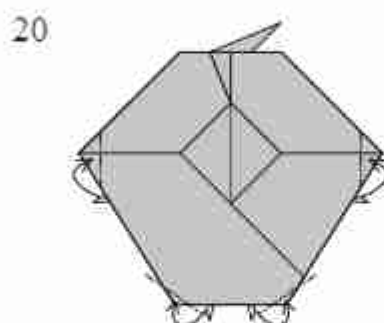

Mountain-fold and unfold.

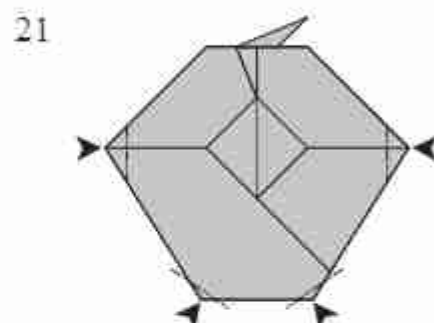

Round the apple by closed sinking the left and right corners and reverse-folding the two bottom corners.

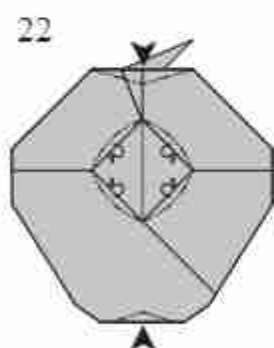

Shape the apple and the worm hole to taste.

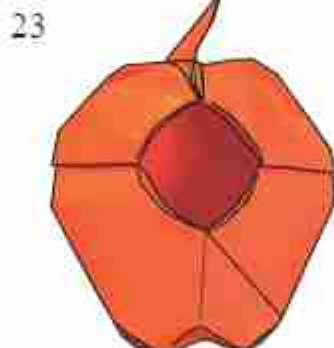

Holy Apple! The Worm in an Apple is ready to make its grand debut! Ask the audience, "What is this?" When they say, "an apple," ask, "What kind of apple?" To whatever response you get, answer, "It is an apple with a worm! But where is the worm?... Wait, here it comes!"

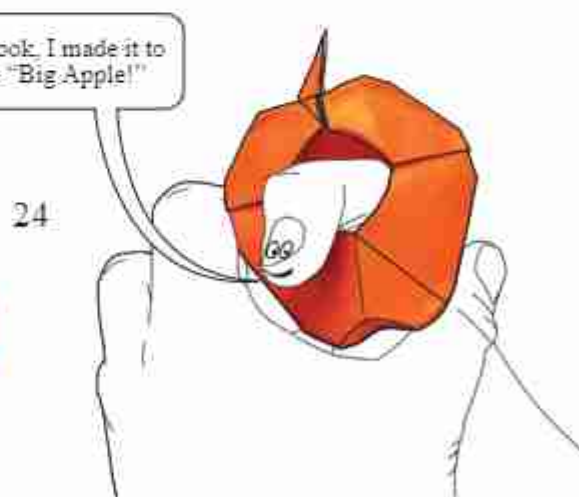

Holding the apple in your left hand, insert your right index finger into the bottom of the model and out the worm hole as shown. To make the worm more cute, draw a face on your finger. To make the scene more realistic, use a real worm! And, while your at it, use a real apple!

Sailboat

Simple

Herdy Soepono

Hadi Tahir. (dgrms.)

©2021 - Indonesia

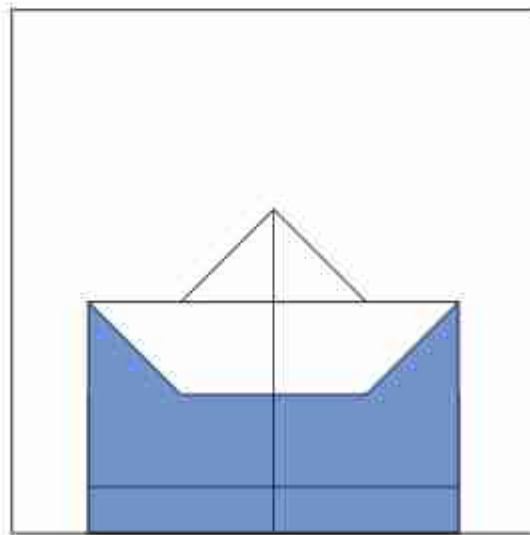
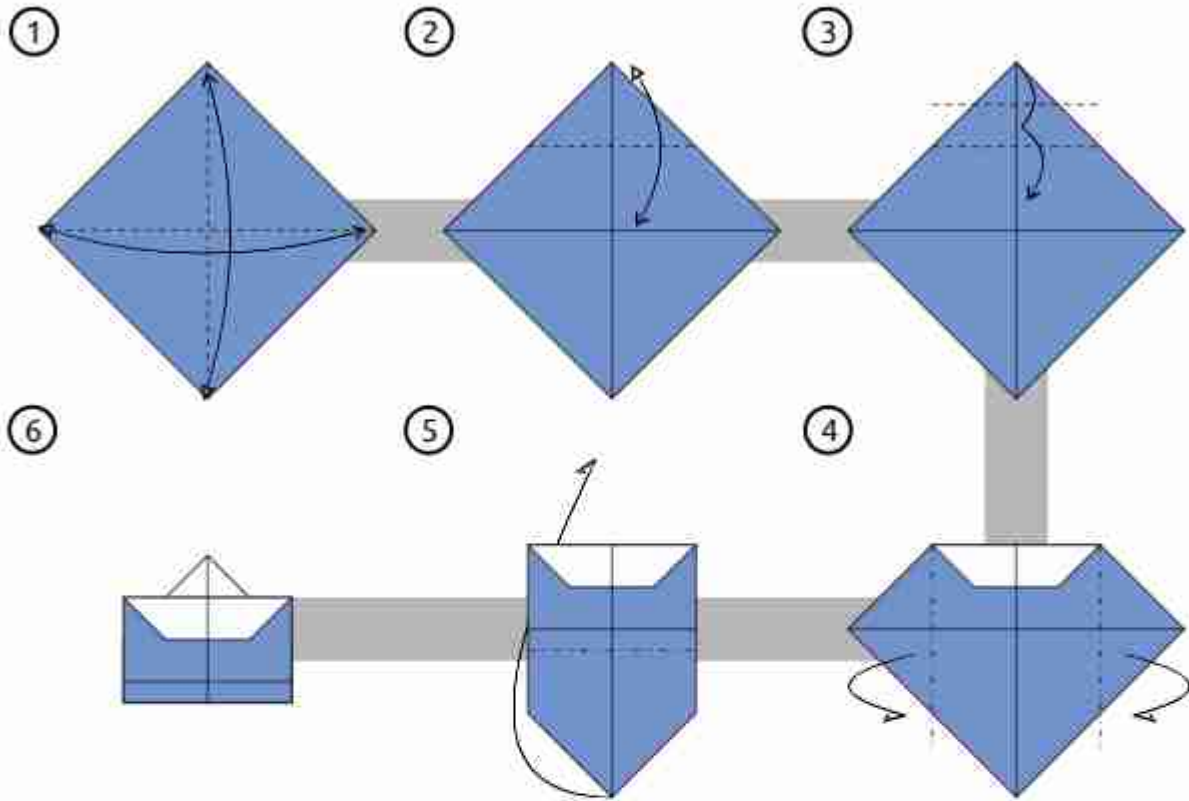

California Sea Lion

Intermediate

John Szinger

©2021 - USA



These aquatic mammals are popular denizens of the California coast. Unlike seals, they can walk on land on all four flippers, and have external ear flaps. California sea lions are known for their intelligence, playfulness and noisy barking. Sea lions began appearing at San Francisco's Pier 39 in 1989. They have found an ideal home, and hundreds can be found there any time of the year.

Recommended paper: 8" or larger square. Begin with a square, white side up.

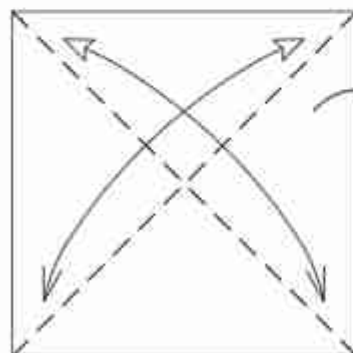

1. Fold and unfold on the diagonals. Turn the model over.

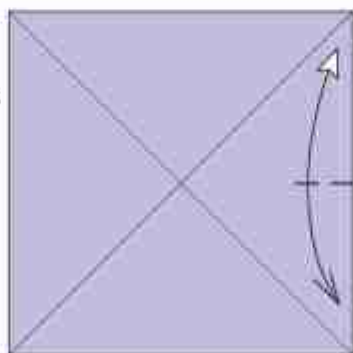

2. Fold in half and unfold, creasing only at the right edge.



3. Fold from the corner to the landmark and unfold, creasing only the middle.

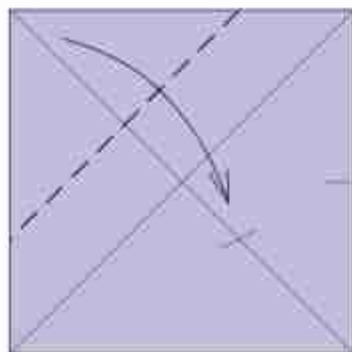

4. Fold the corner to the mark.

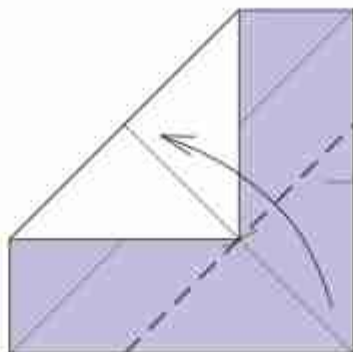

5. Fold the opposite corner. This divides the paper in thirds.

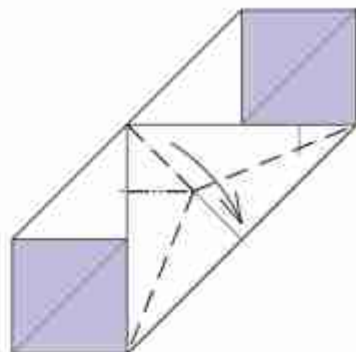

6. Rabbit ear.

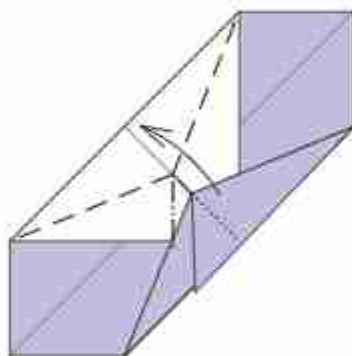

7. Rabbit ear the opposite corner.

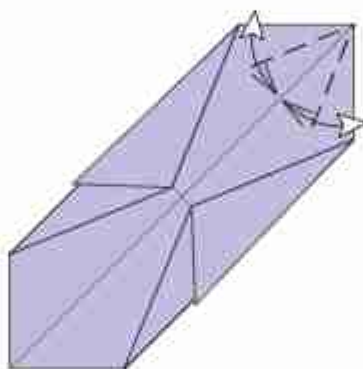

8. Fold and unfold.

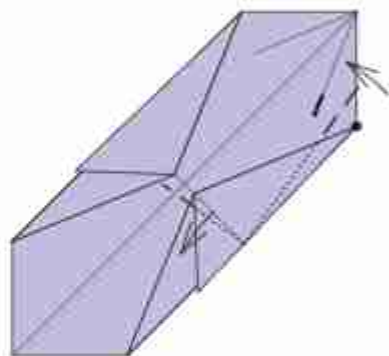

9. Slide the flap so the point meets the mark and flatten.

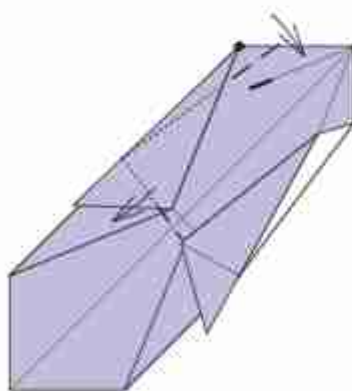

10. Repeat step 9 on the other side.

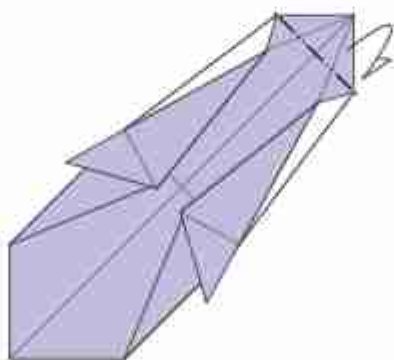

11. Mountain fold the flap behind.

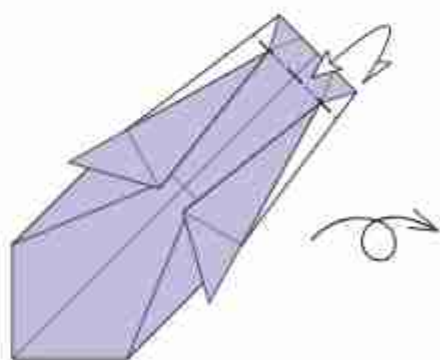

12. Mountain fold and unfold. Turn the model over.

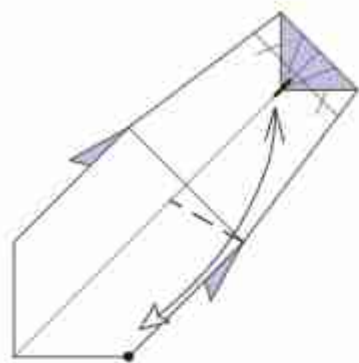

13. Fold the corner to the mark and unfold.

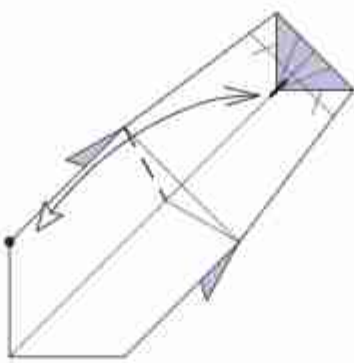

14. Repeat step 13 on the other side.

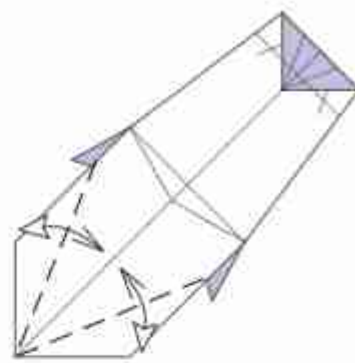

15. Fold and unfold.

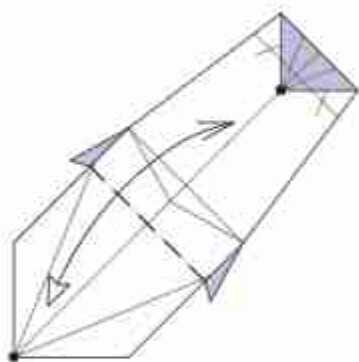

16. Fold the corner to the mark and unfold.

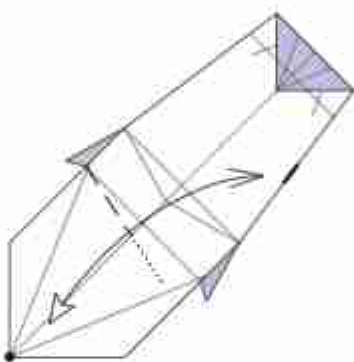

17. Fold the corner to the mark and unfold.

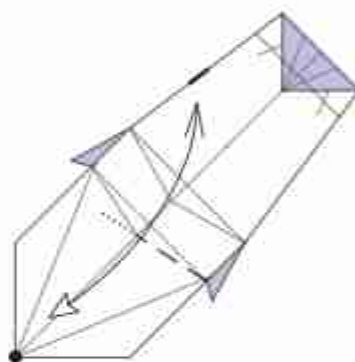

18. Repeat step 17 on the other side.

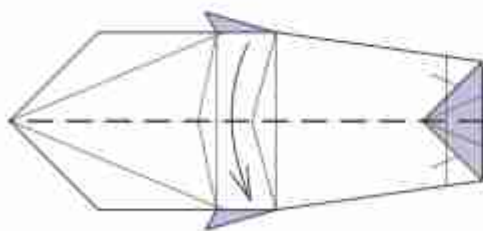

19. Fold the model in half.

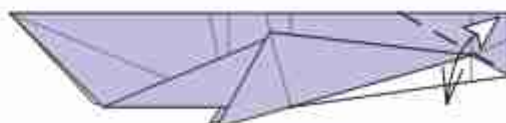

20. Fold and unfold.

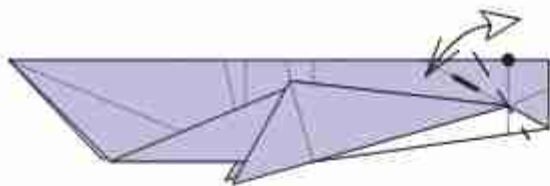

21. Fold the point to the mark and unfold.

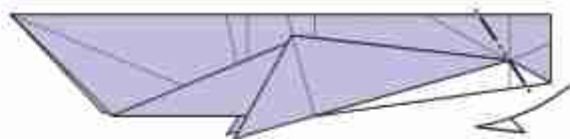

22. Reverse fold.

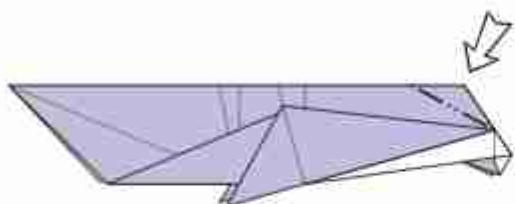

23. Sink.

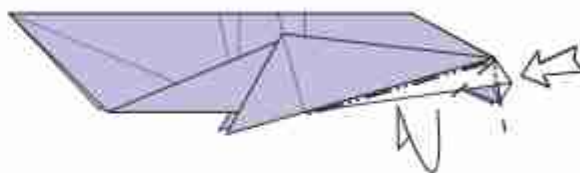

24. Swivel fold a layer inside at the bottom; repeat behind.

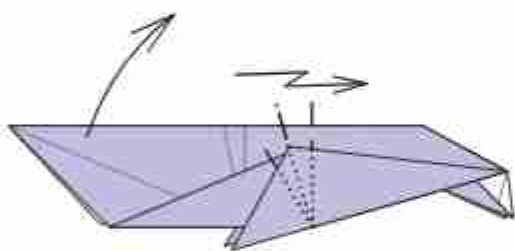

25. Crimp the middle of the model. Flatten the layer beneath the rabbit-ear; repeat behind.

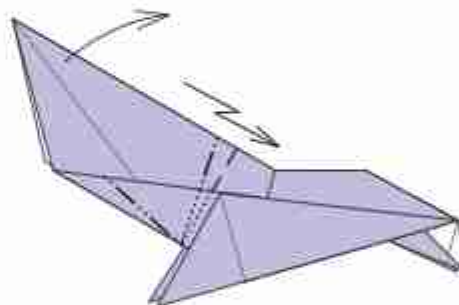

26. Crimp the middle again. Flatten the layer at the side; repeat behind.

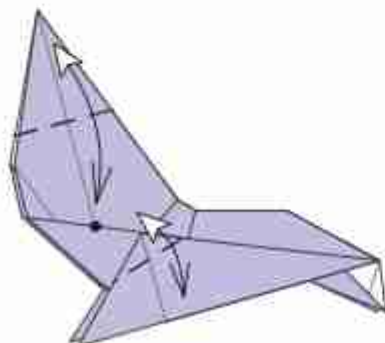

27. Fold and unfold at the head. Fold and unfold at the shoulder; repeat behind.

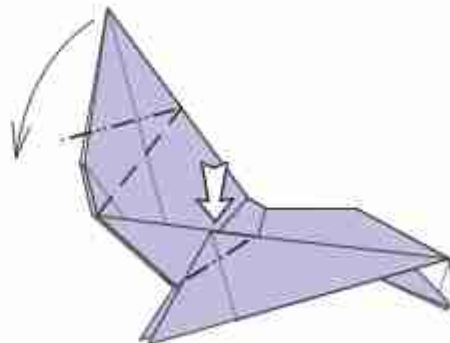

28. Crimp at the head. Spread-squash at the shoulder; repeat behind.

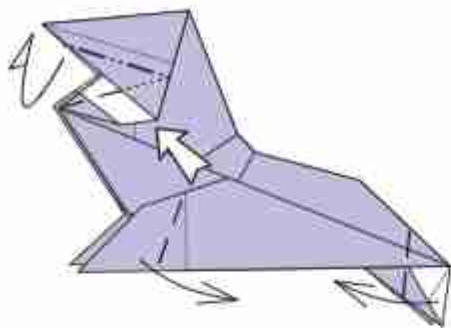

29. Swivel fold a layer inside to narrow the head; repeat behind. Fold the flippers; repeat behind.

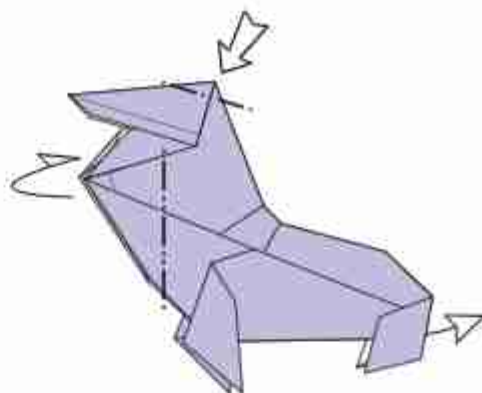

30. Closed sink on the head. Fold a flap inside to narrow the neck; repeat behind. Slide the rear flippers out and flatten.

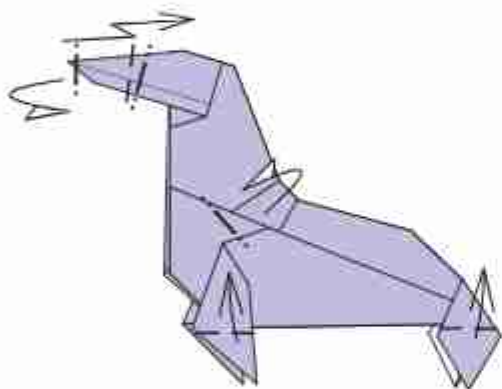

31. Crimp to form the snout; reverse fold the tip of the nose. Tuck in a layer at the shoulder; repeat behind. Fold the flippers up; repeat behind.

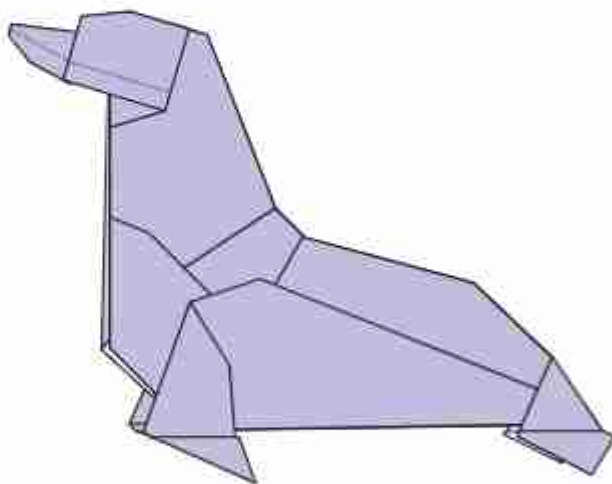

32. Sea Lion.

Kettenkraftrad

Intermediate

Hadi Tahir

©2020 - Indonesia

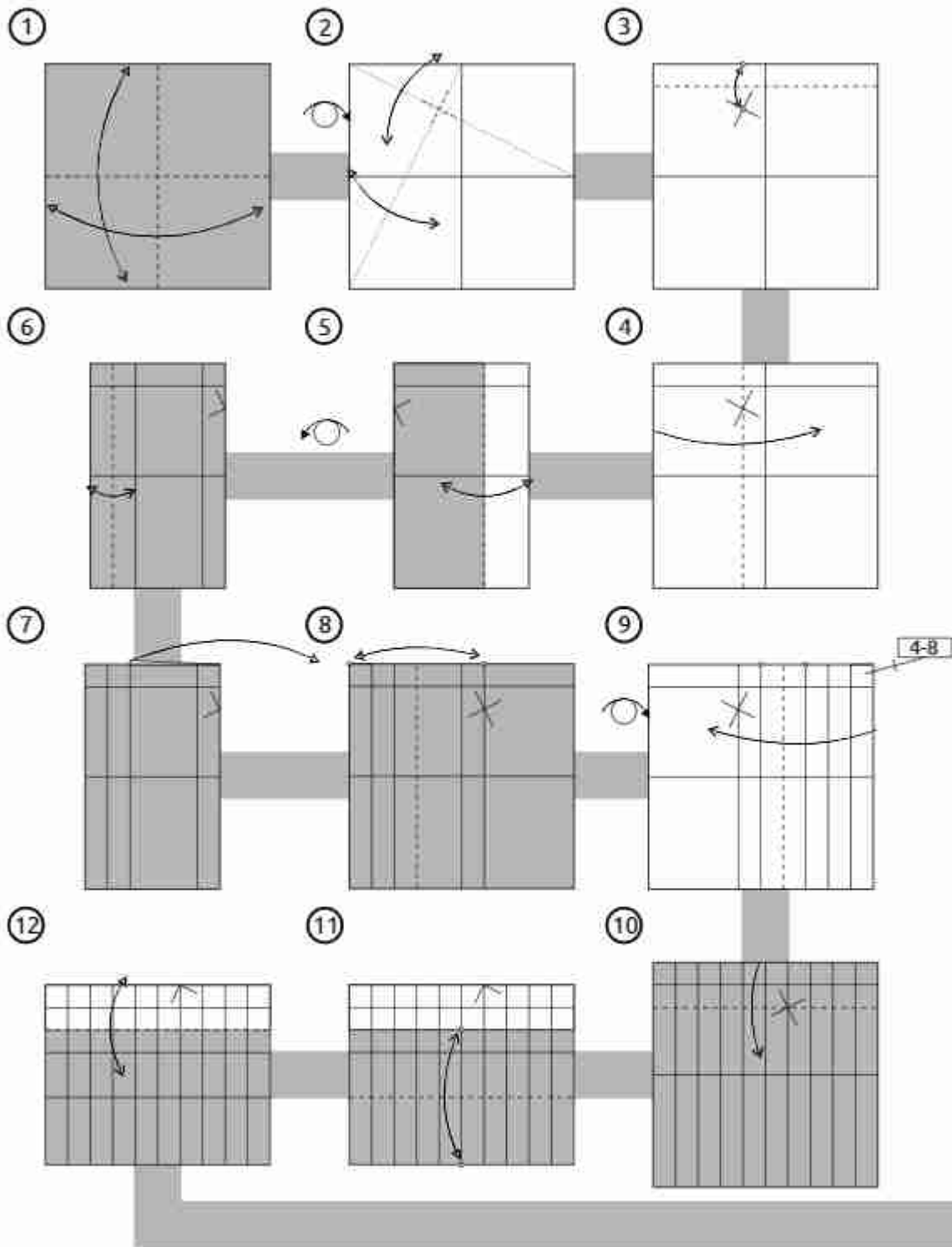

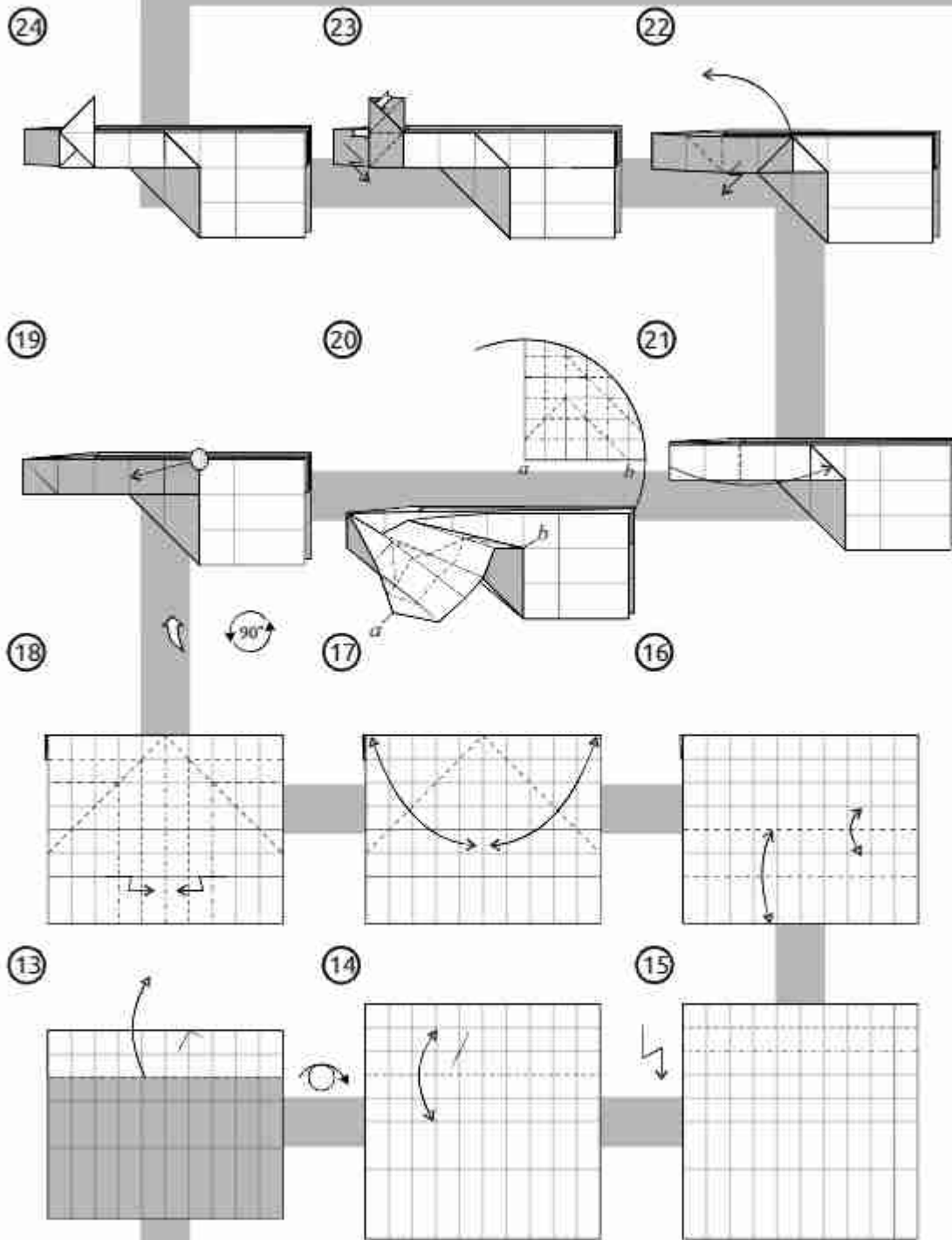

25
20-24

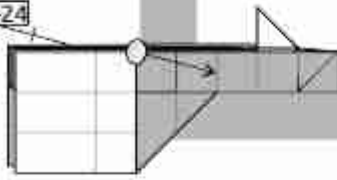

26

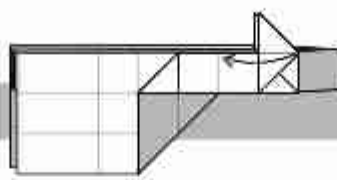

27

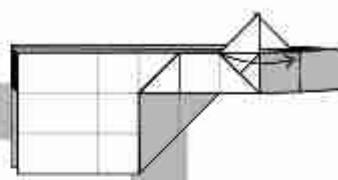

30

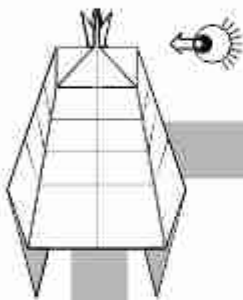

29

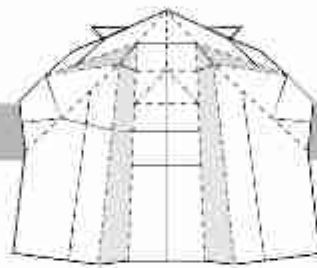

28

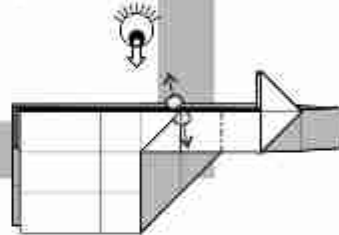

31

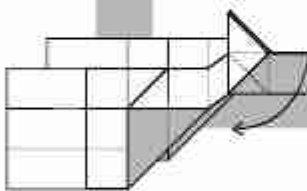

32

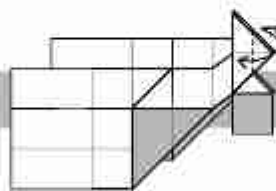

33

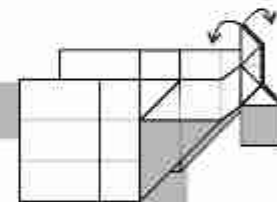

36

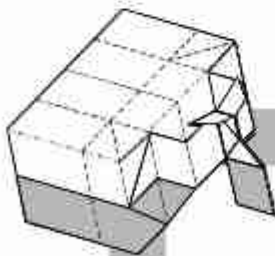

35

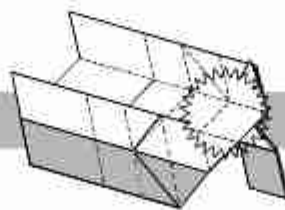

34

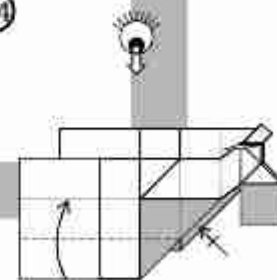

perbandingan ukuran kertas
dan ukuran model jadi

*ratio between the paper size
and finished model size.*

使用した紙と完成作品のサイズ比較。

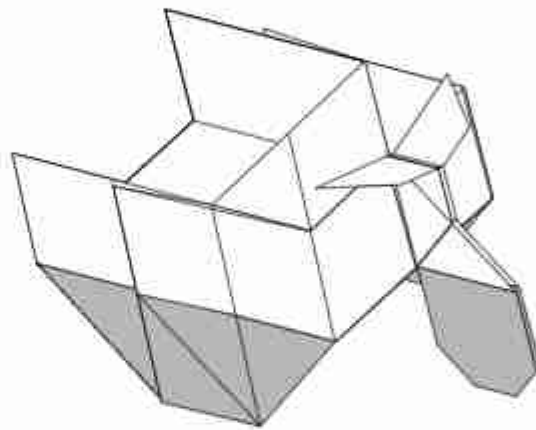
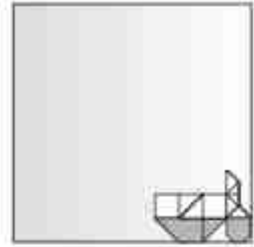

37

38

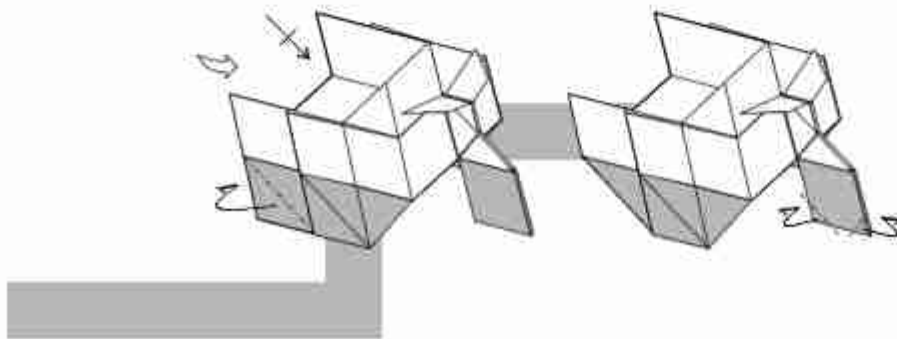

Two Hearts

Intermediate

Hadi Tahir

©2020 - Indonesia

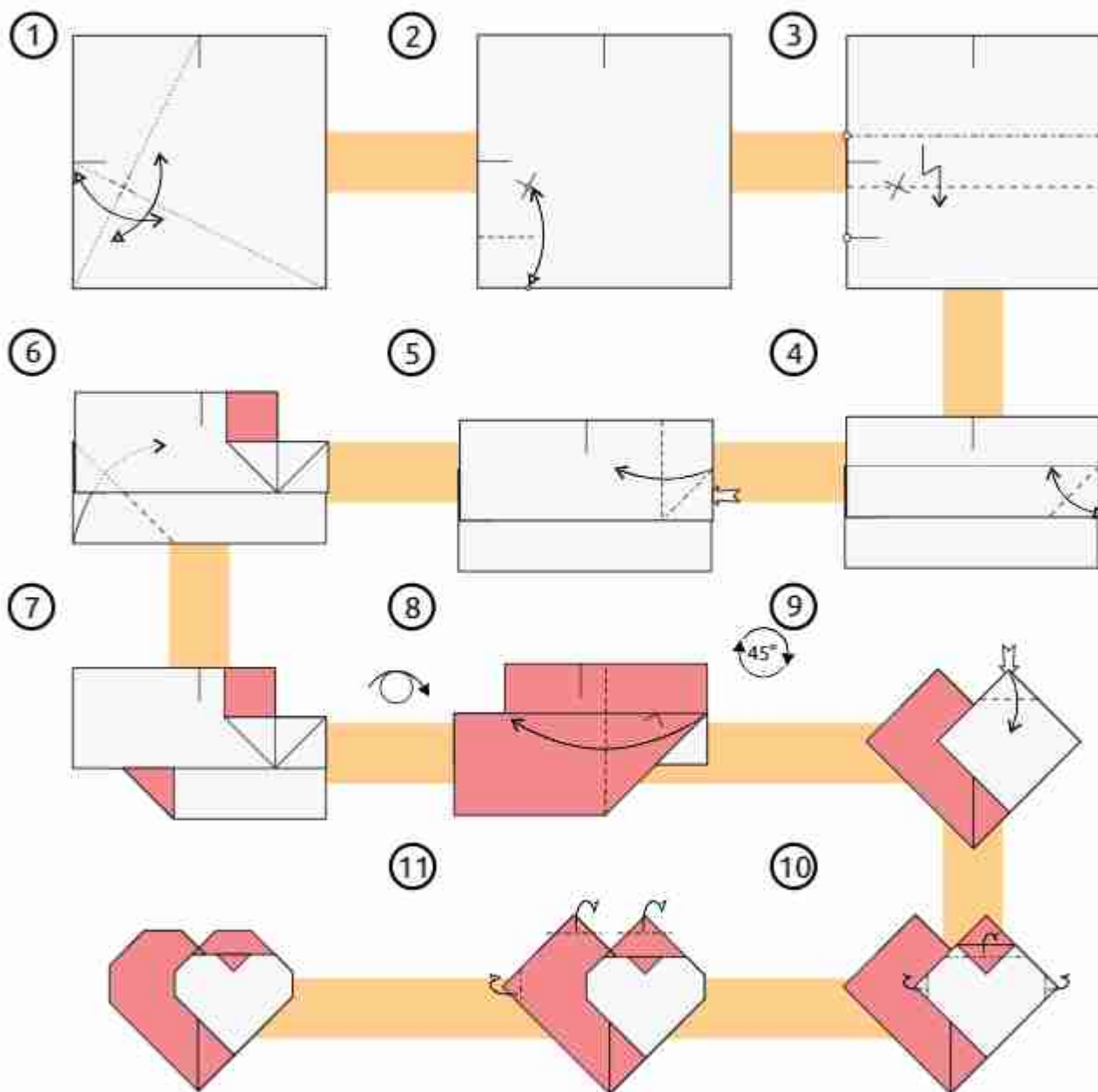

Rooster

Nicolas Terry

©2022 - France

Complex

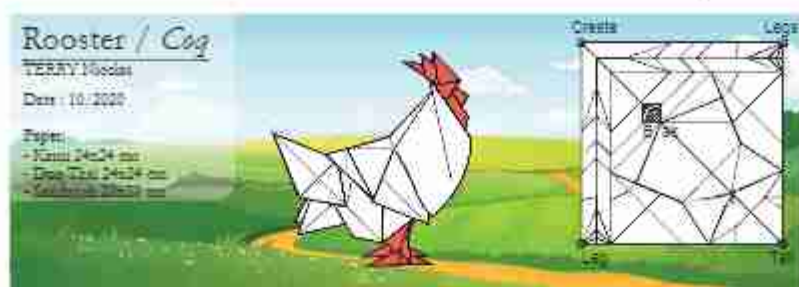

1

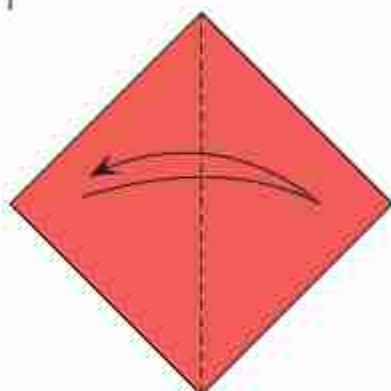

2

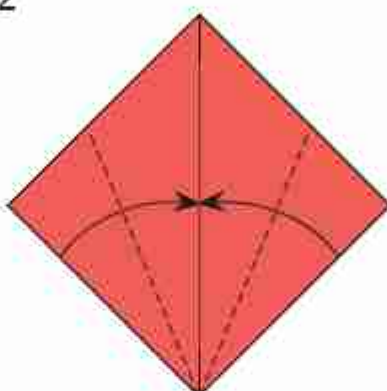

3

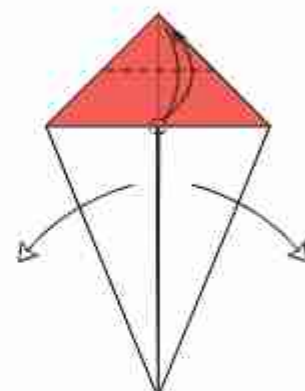

4

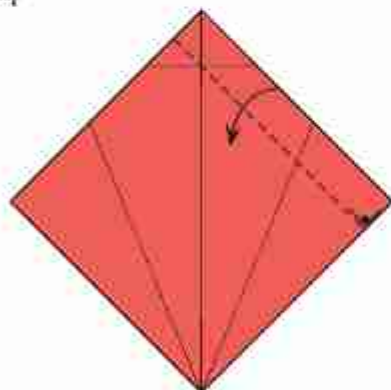

5

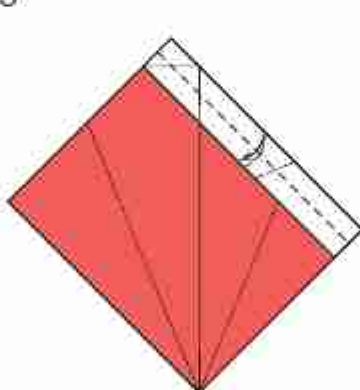

6

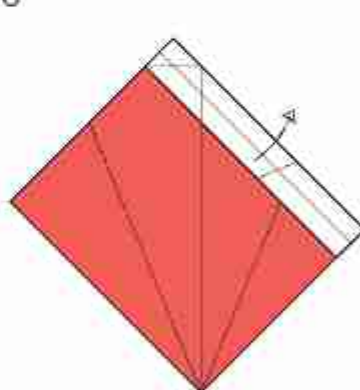

7

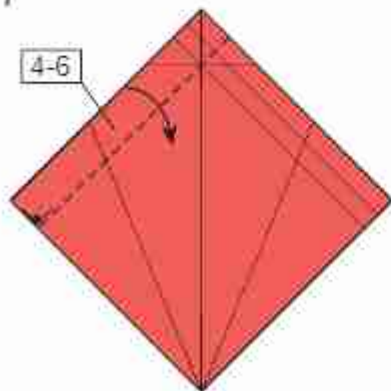

8

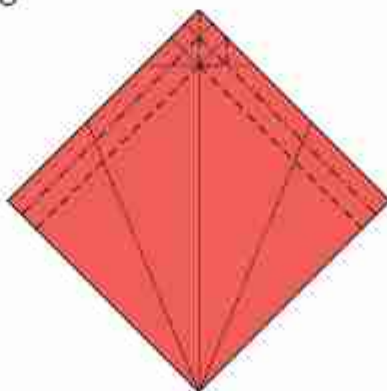

9

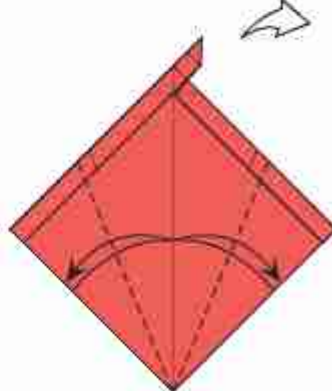

10

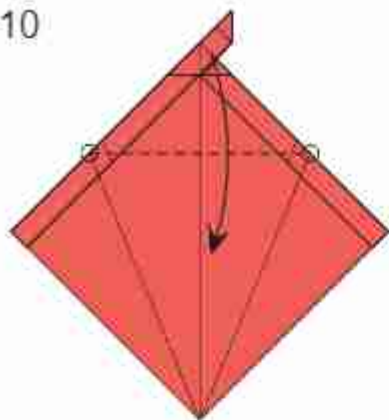

11

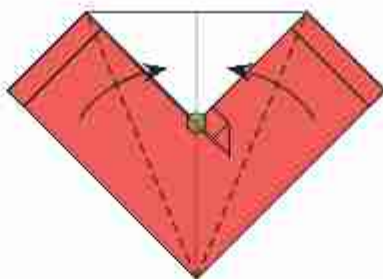

12

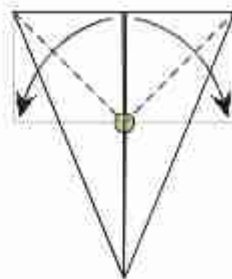

13

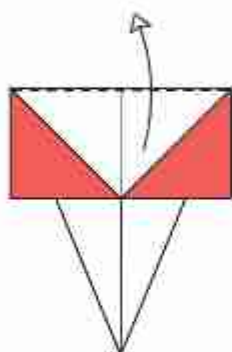

14

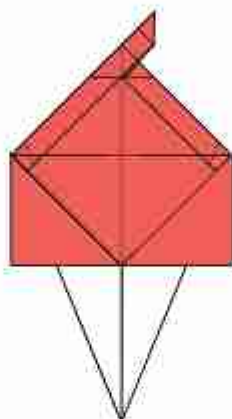

15

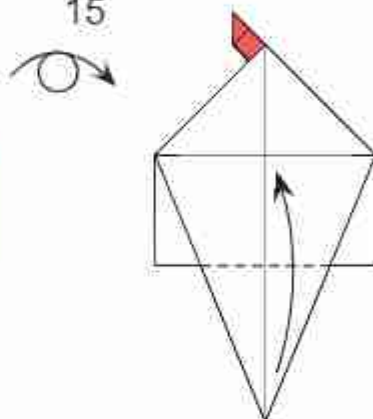

16

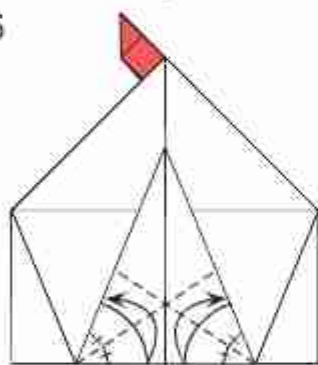

17

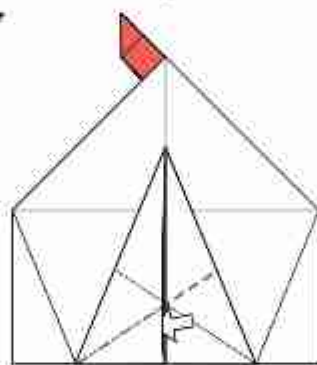

18

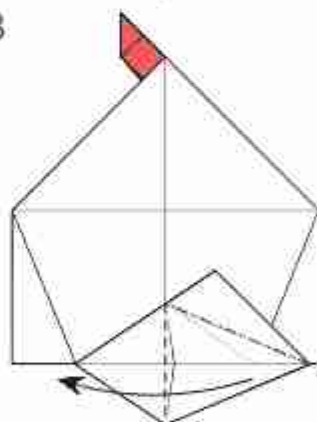

19

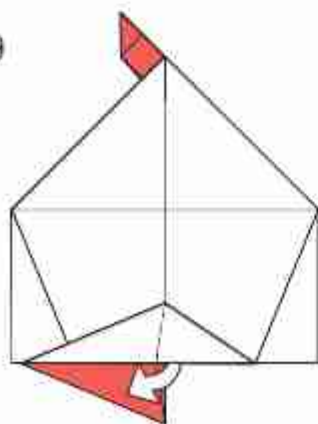

Pull out the hidden flap.

20

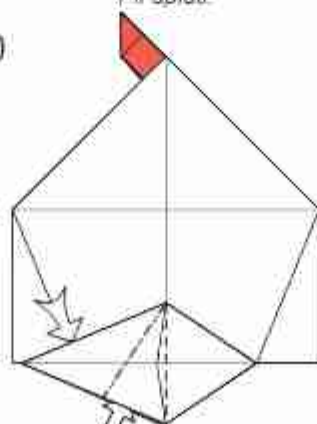

Squash-fold.
Pli aplati.

Squash-fold.

21

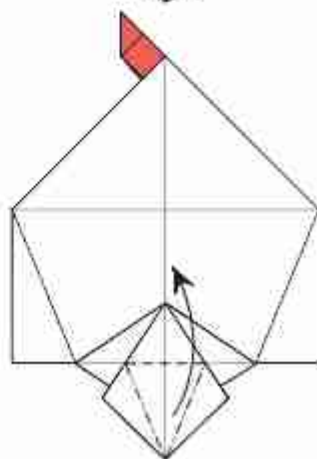

22

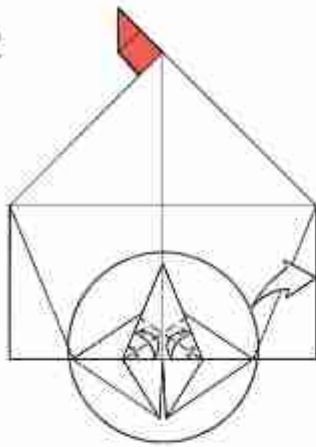

23

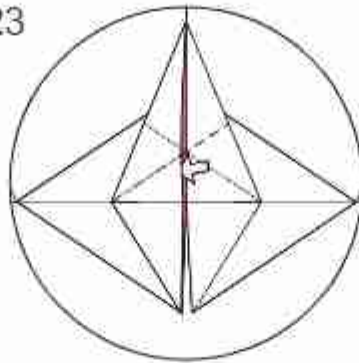

Squash-fold

24

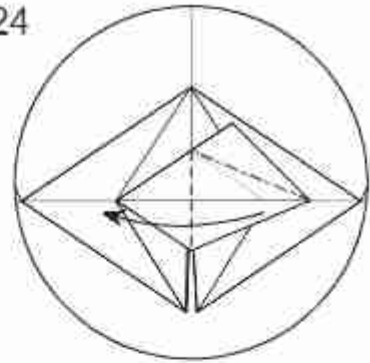

25

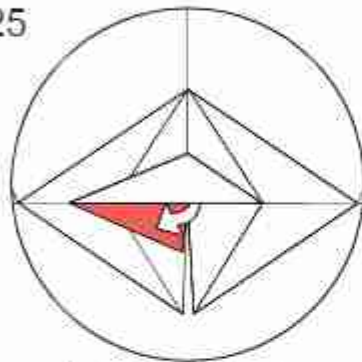

Pull out the hidden flap.

26

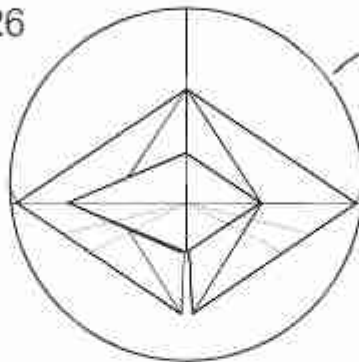

27

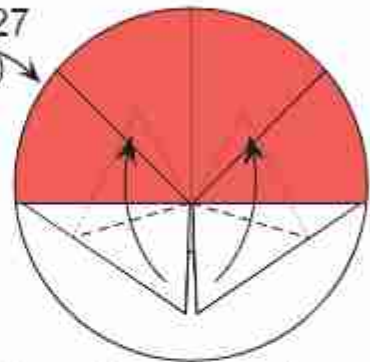

See next step to find the references.

28

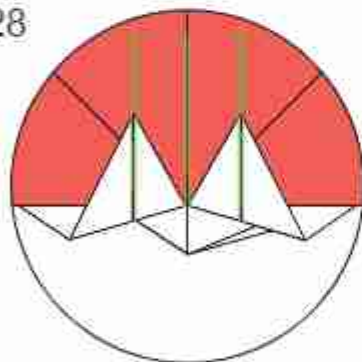

29

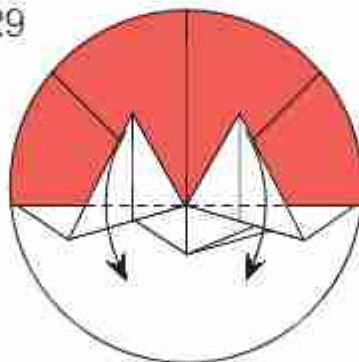

30

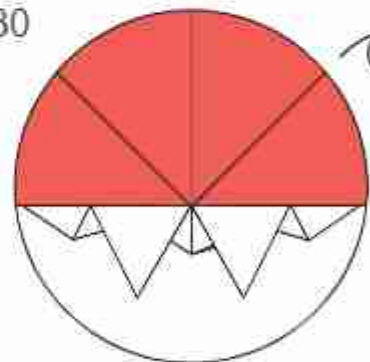

The folds are parallels to the central axis.

31

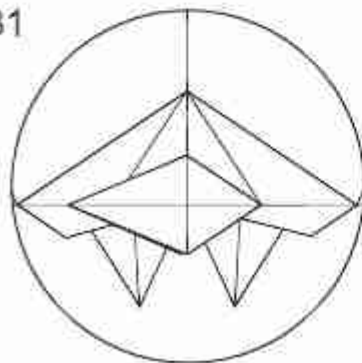

32

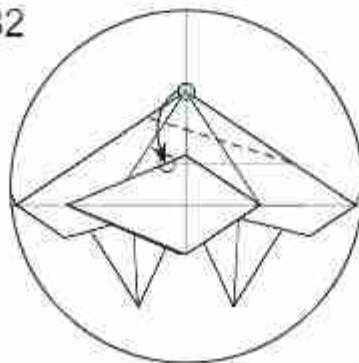

33

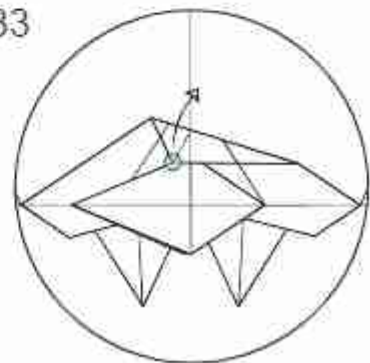

34

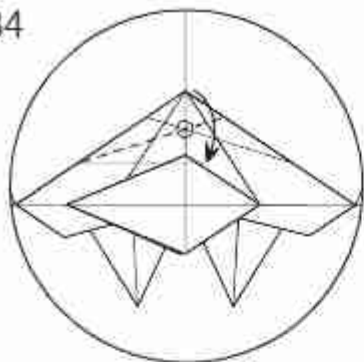

35

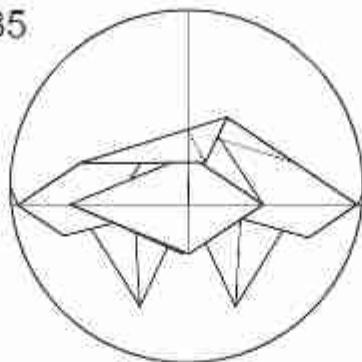

36

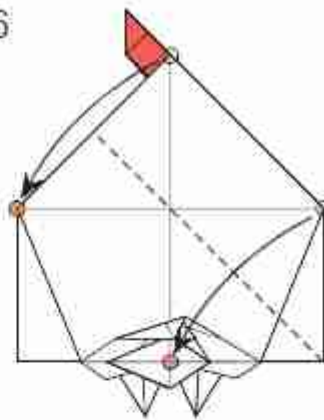

37

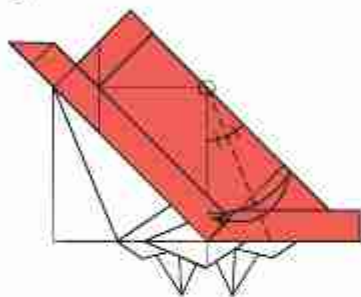

Fold only the red layer.

38

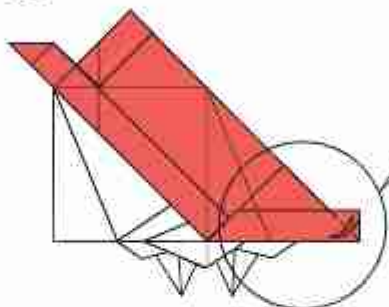

39

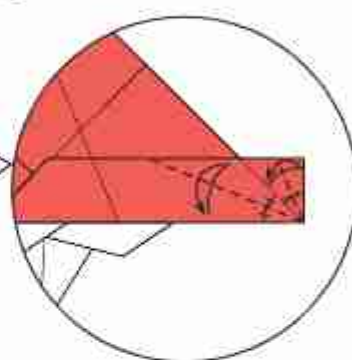

40

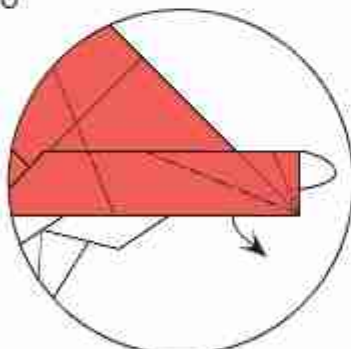

Inside reverse-fold.

41

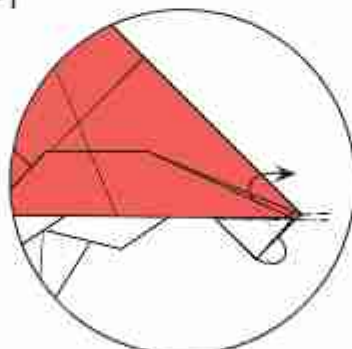

Inside reverse-fold.

42

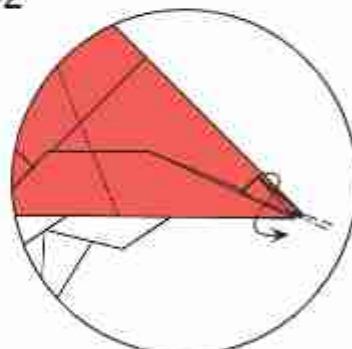

Inside reverse-fold.

43

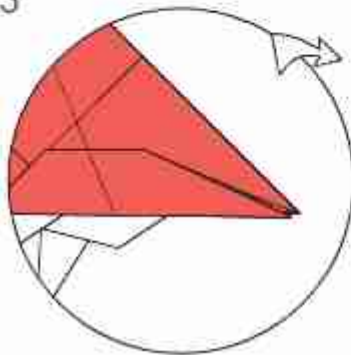

44

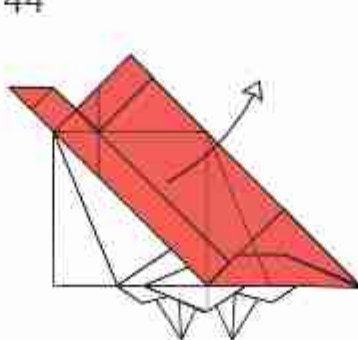

45

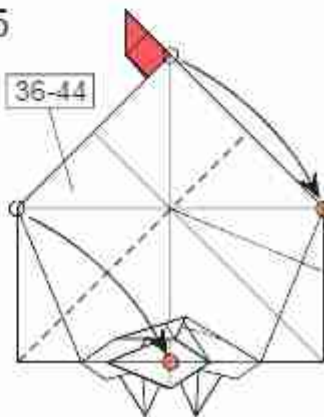

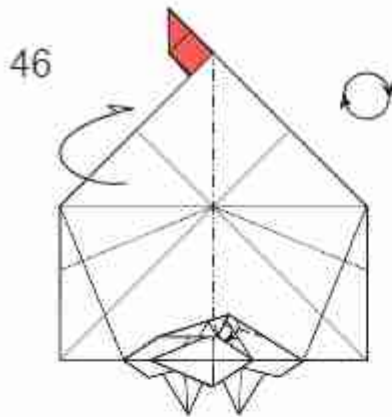

Fold in half including a swivel-fold on the tail.

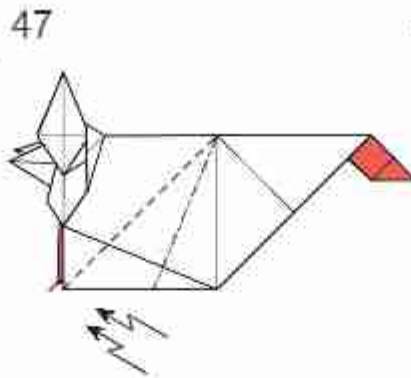

Crimp outside.

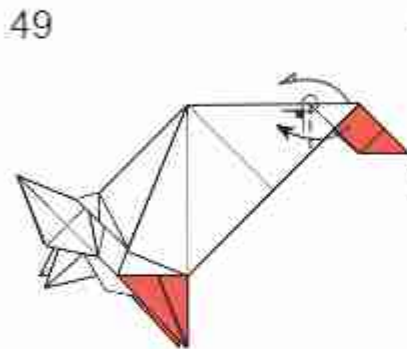
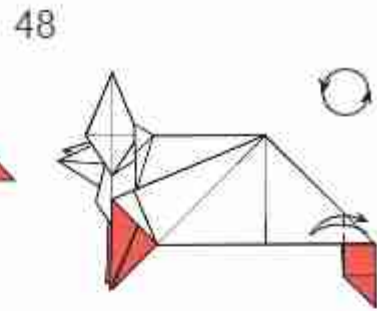

Outside reverse-fold.

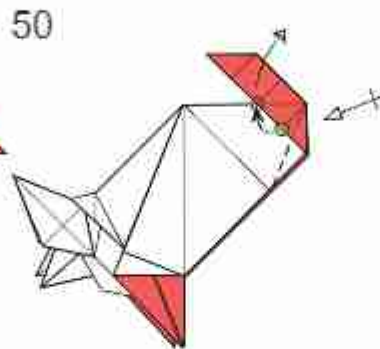

Swivel-fold on both side in same time.

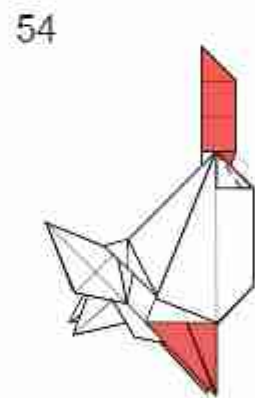
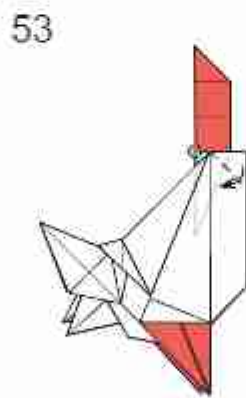
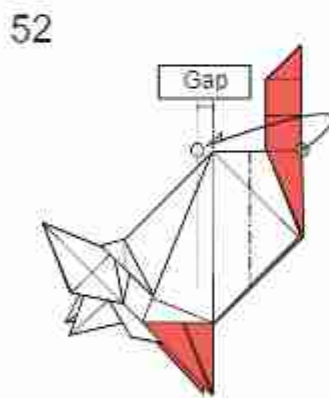
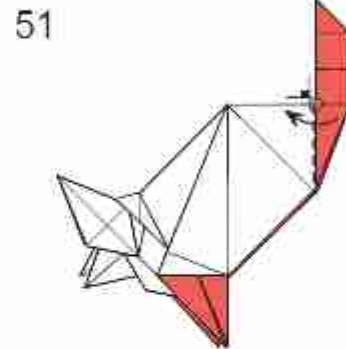

To find this reference, imagine the position and final size of the beak.

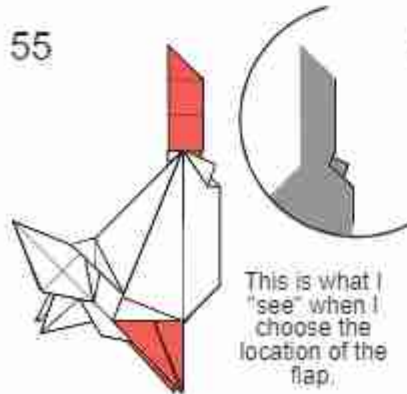

This is what I "see" when I choose the location of the flap.

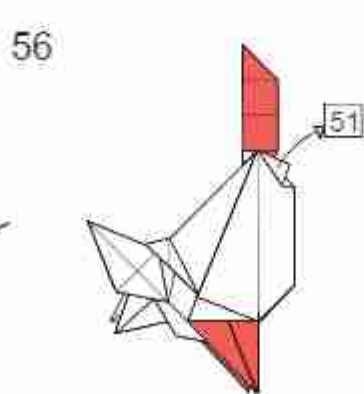

Unfold until step 51.

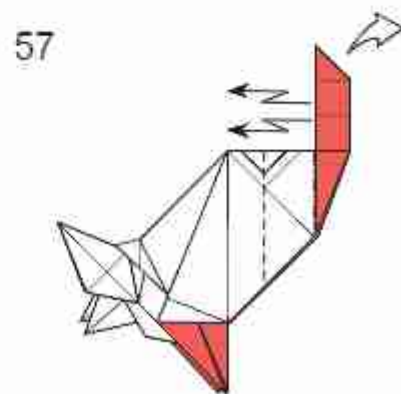

Crimp outside.

58

Crimp
outside.

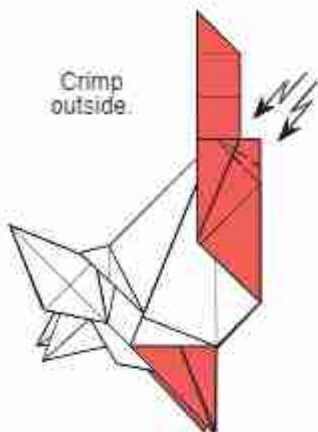

59

Adjust the beak if
necessary.

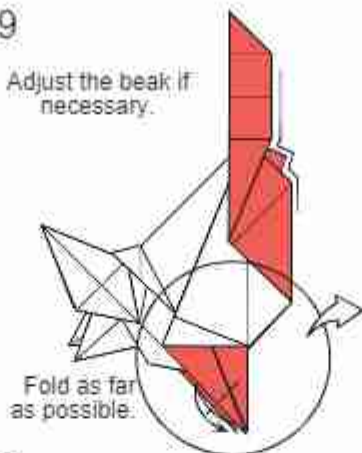

Fold as far
as possible.

60

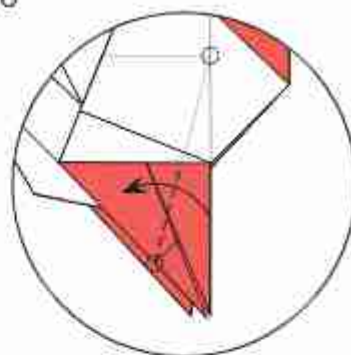

61

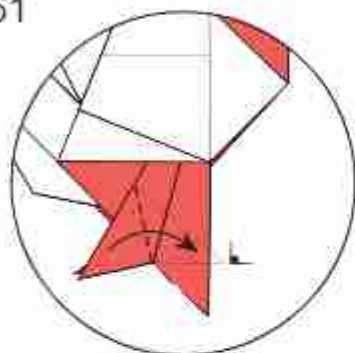

62

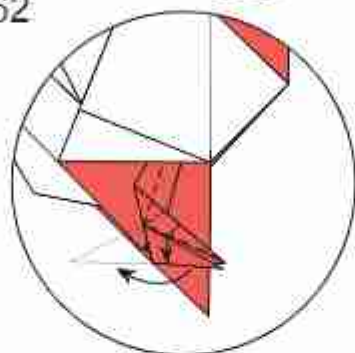

Move back one toe
then swivel-fold.

63

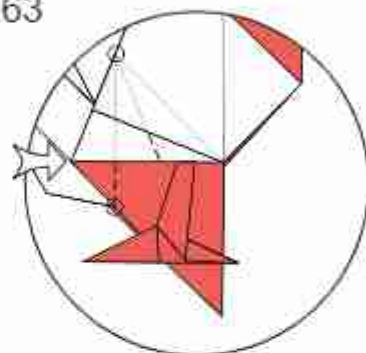

Swivel-fold.

64

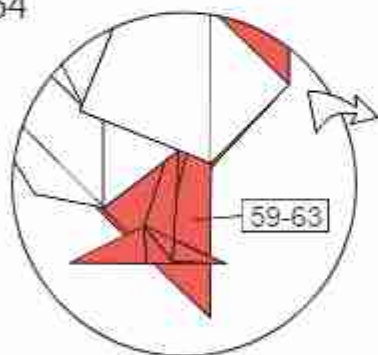

65

Fold then
unfold
through all
layers

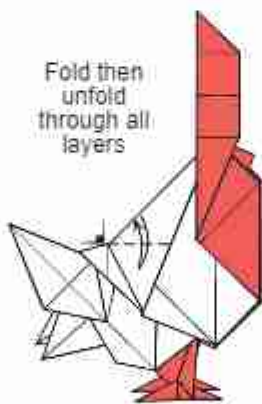

66

Fold then
unfold
through all
layers

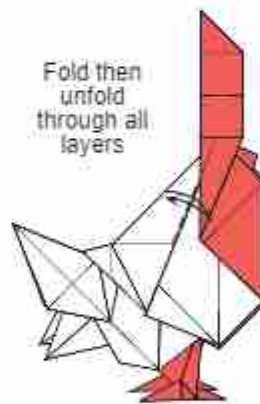

67

Rabbit-ear
fold through
all layers.

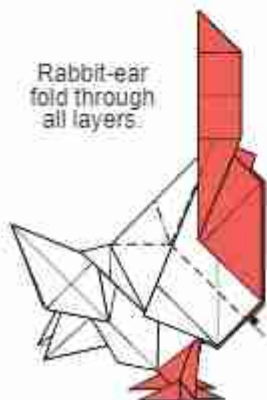

68

Unfold

67

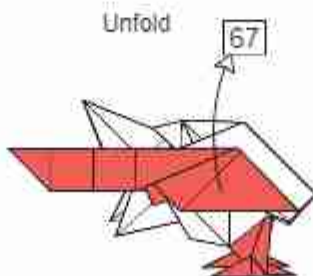

69

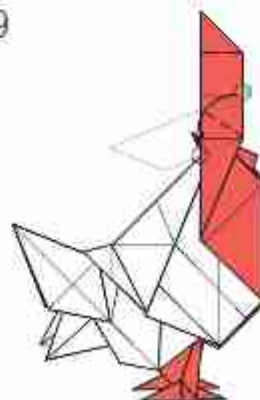

70

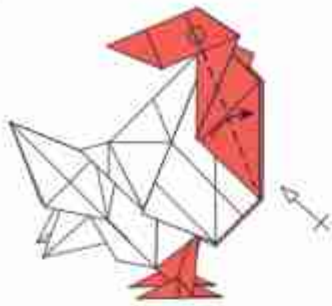

71



72

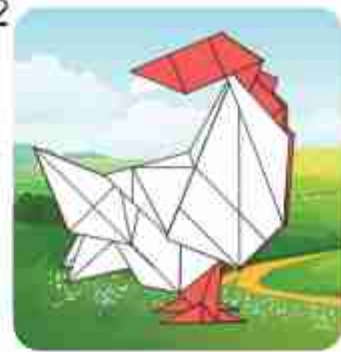

Geometric rooster.

70



This geometric rooster doesn't need more shaping to have a certain presence. However, we may be tempted to bring a little more detail and roundness.

Start from step 70 and unfold.

71

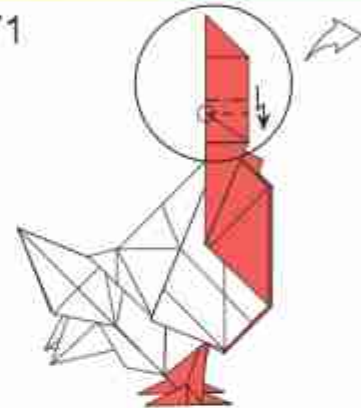

72

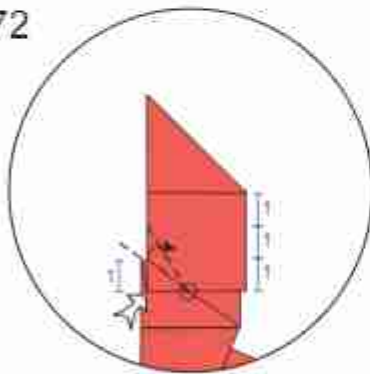

73

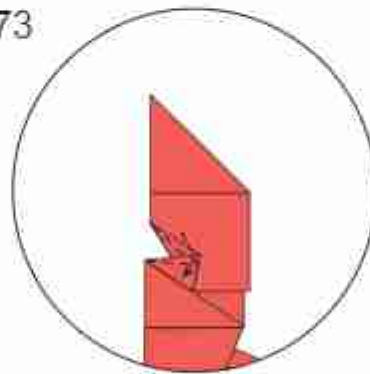

74

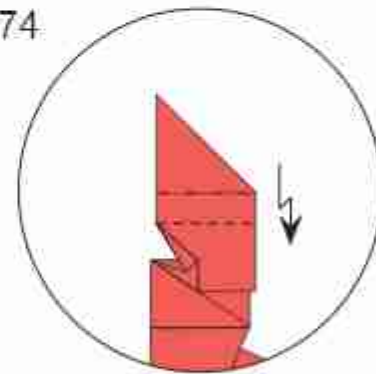

Optional : swivel-foi to refine the tip.

75

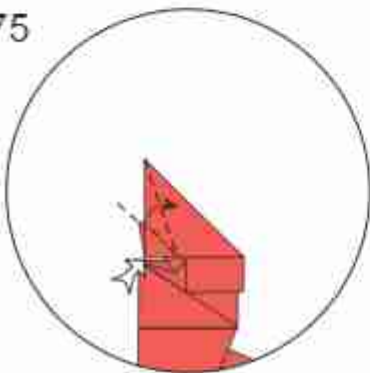

76

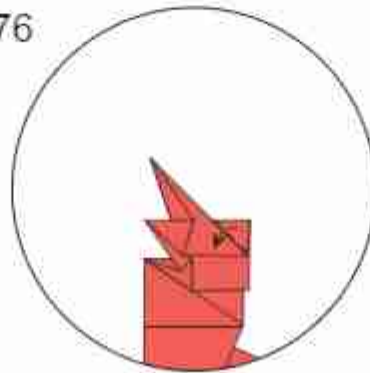

77

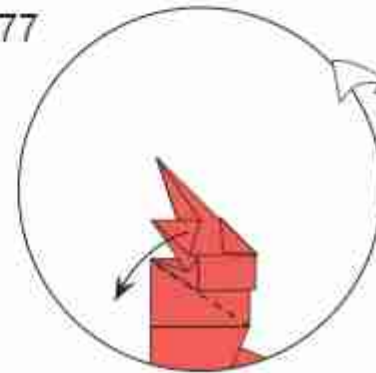

78

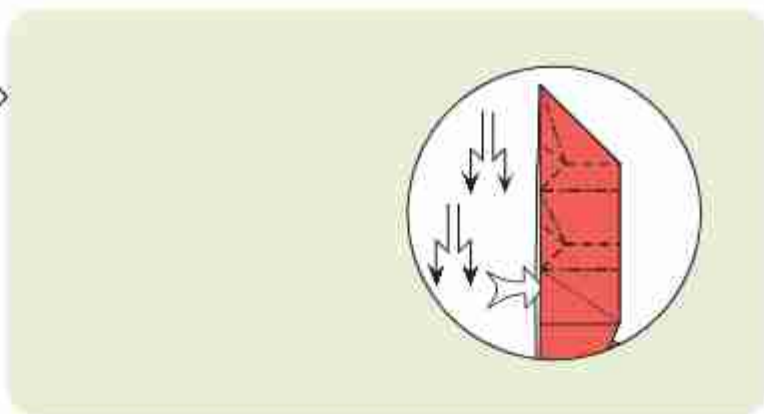
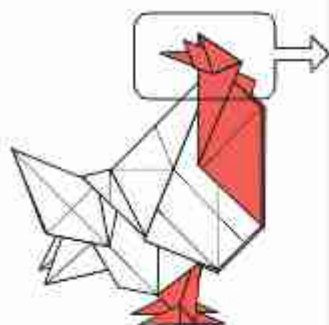

79

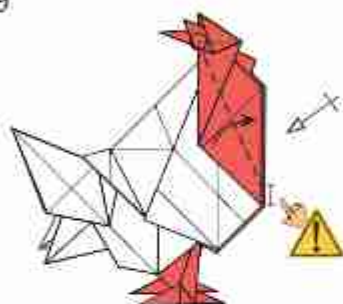

Note the small gap.

80

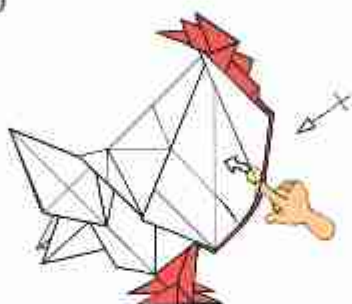

The flap is not flat.
Reverse the concavity.

81

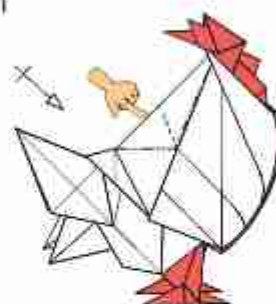

Make a 3D back.

82

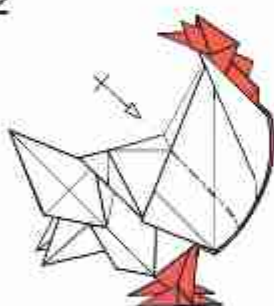

Pinch the existing mark to make
it as a mountain-fold.

83

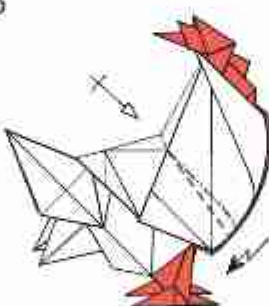

The pleat-fold lock the 3D back.
You can just pleat-fold the first layer.

84

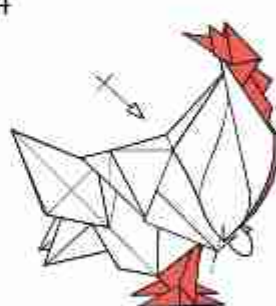

Lock the pleat-fold with a tiny
hidden swivel-fold (or just mountain-
fold everything that's beyond).

85



Shape the feet.

86

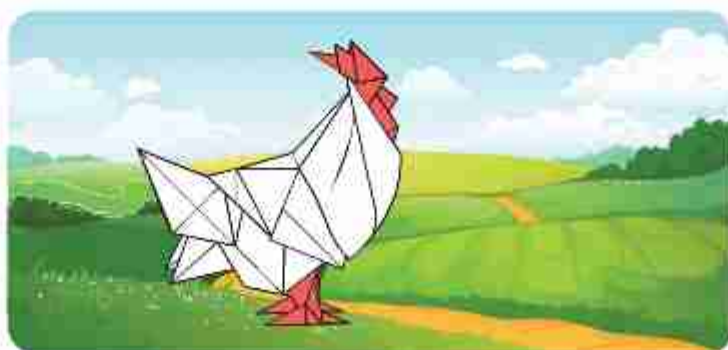

Turtle Love

High Intermediate

Quentin Trollip

©2020 - Canada

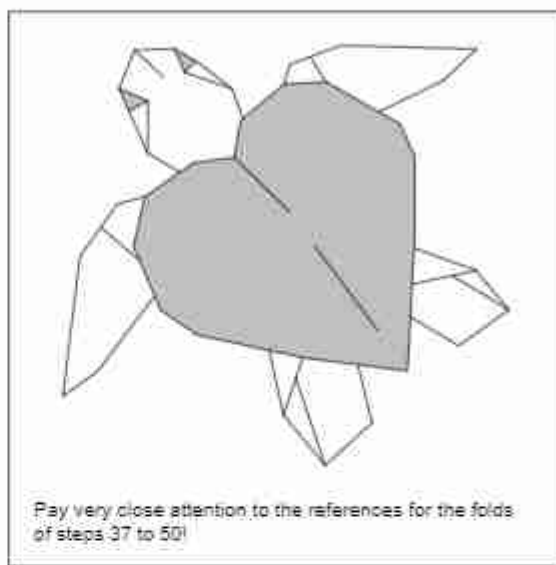
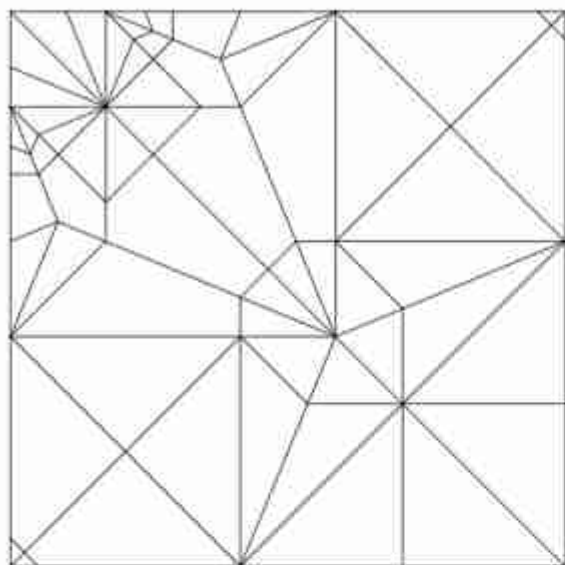

Date created: 19 November 2020

Recommended size and ratio: 25 cm = 9.5 cm long

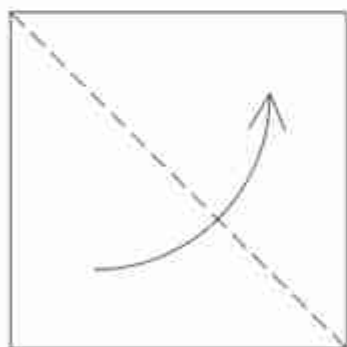

1 Valley fold.

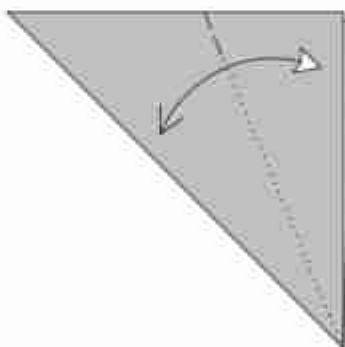

2 Pinch.

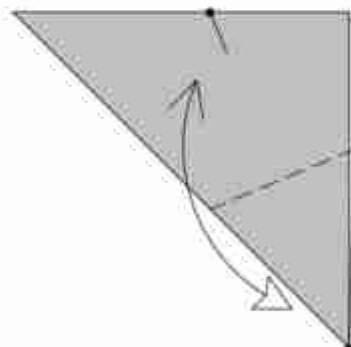

3 Valley fold and unfold.

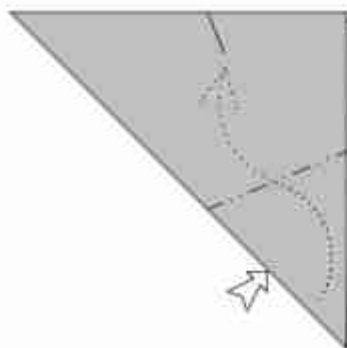

4 Inside reverse fold.

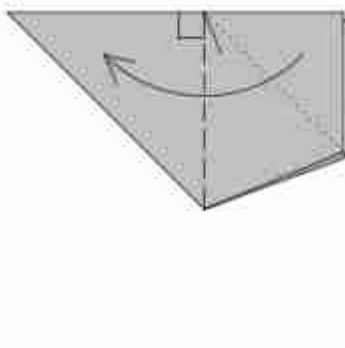

5 Valley fold.

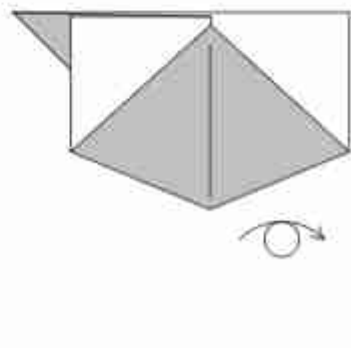

6 Turn over.

7

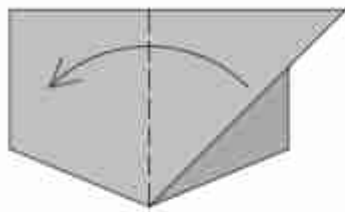

Valley fold.

8

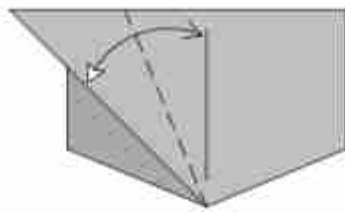

Valley fold and unfold.

9

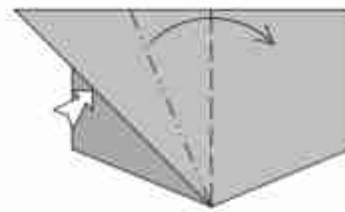

Squash fold.

10

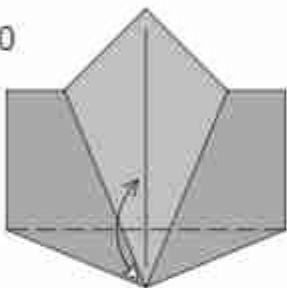

Valley fold and unfold.

11

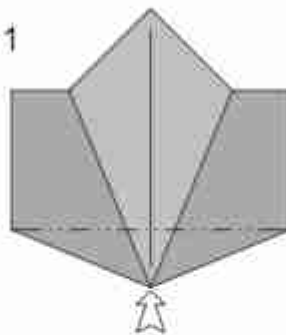

Open sink.

12

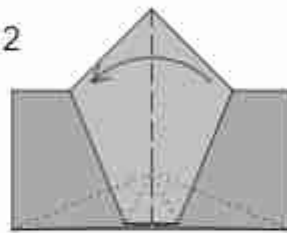

Valley fold.

13

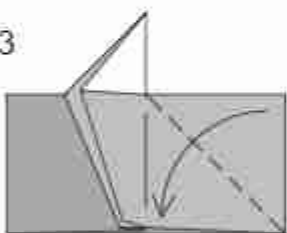

Valley fold.

14

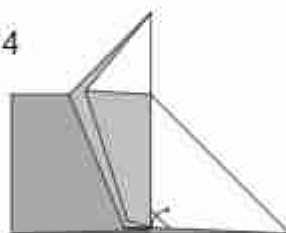

Small valley fold.

15

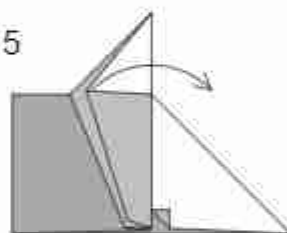

Valley fold.

16

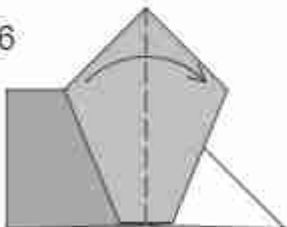

Repeat steps 12 to 15 on the left.

17

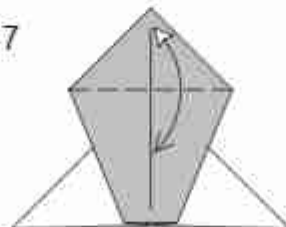

Valley fold and unfold.

18

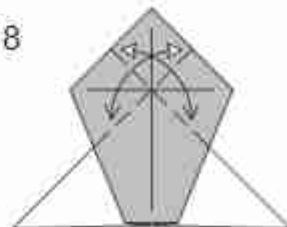

Pre-crease.

19

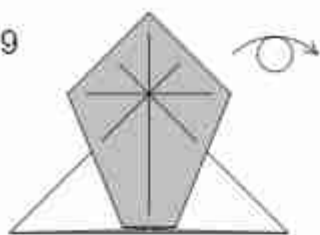

Turn over.

20

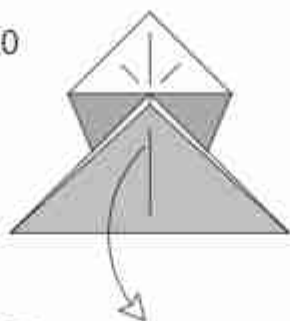

Unfold.

21

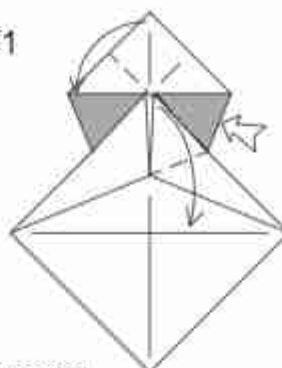

Squash fold.

22

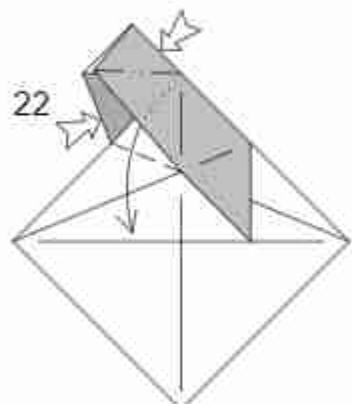

Squash fold.

23

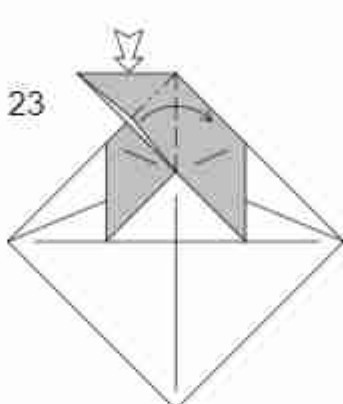

Squash fold.

24

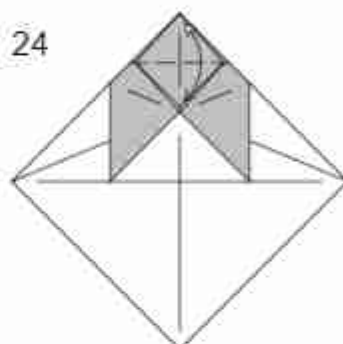

Valley fold and unfold.

25

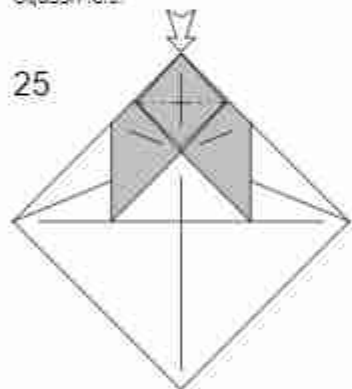

Open sink.

26

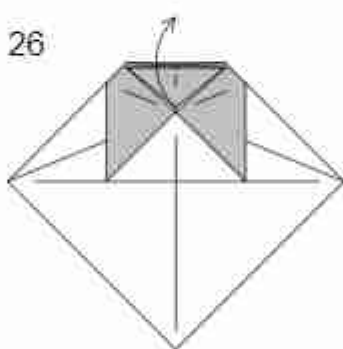

Unfold.

27

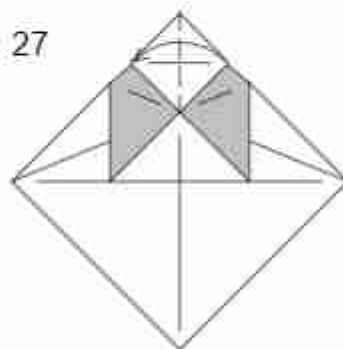

Valley fold.

28

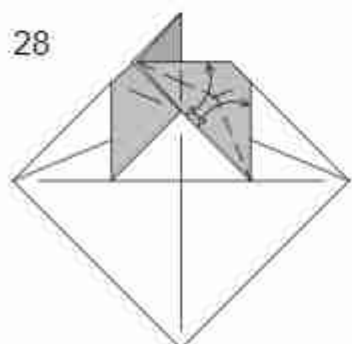

Pre-crease the raw edges.

29

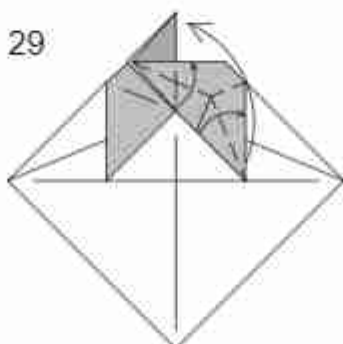

Collapse.

30

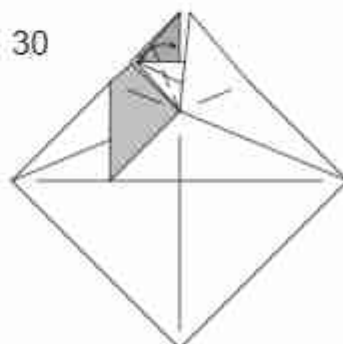

Valley fold and unfold.

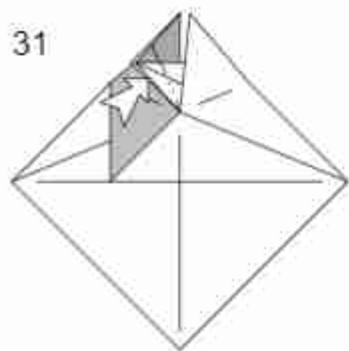

31 Inside reverse fold.

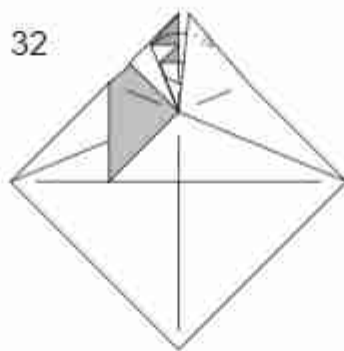

32 Valley fold and place behind.

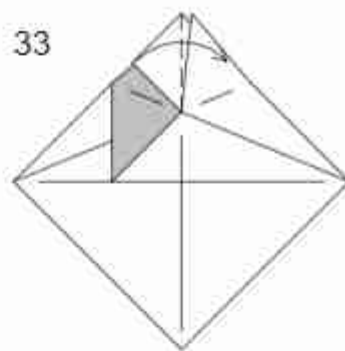

33 Repeat steps 27 to 32 on the left.

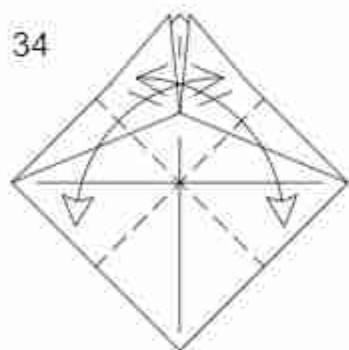

34 Pre-crease.

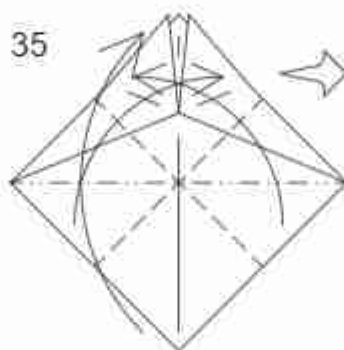

35 Preliminary fold.

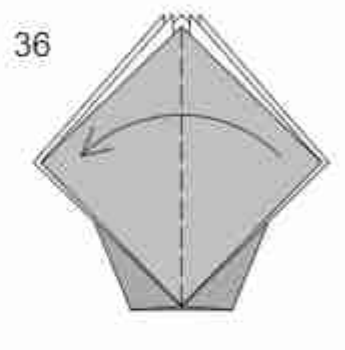

36 Valley fold one layer.

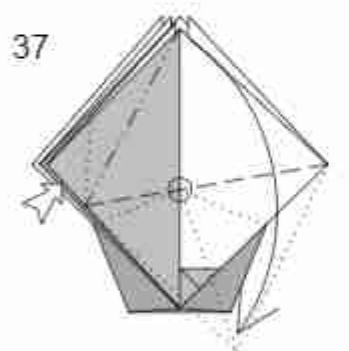

37 Asymmetric squash fold.

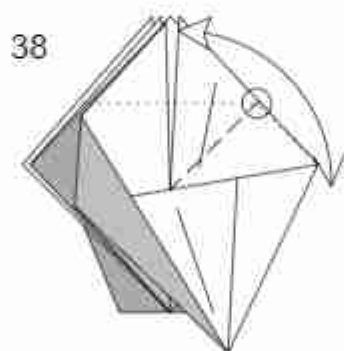

38 Valley fold and unfold.

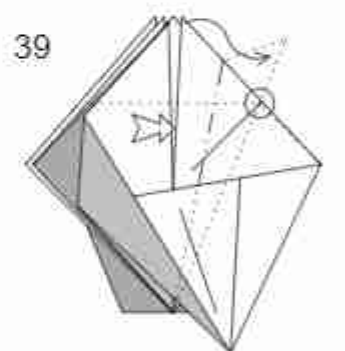

39 Inside reverse fold.

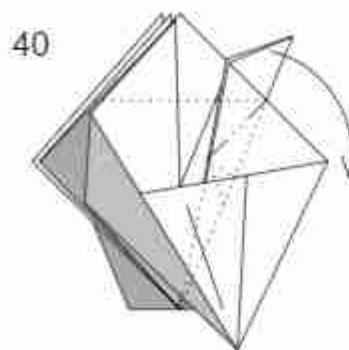

40 Swivel fold.

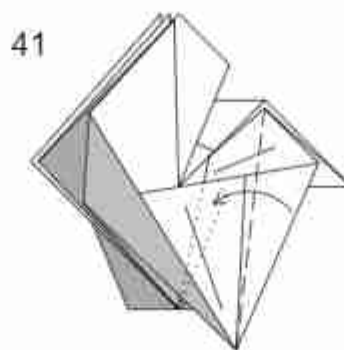

41 Valley fold.

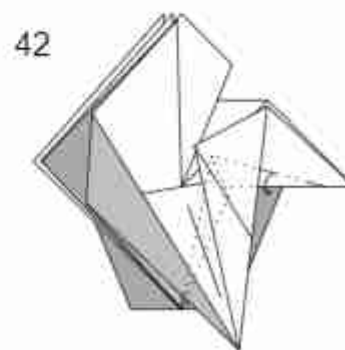

42 Swivel fold behind.

43

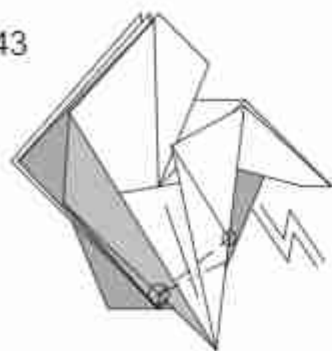

Pleat fold:

44

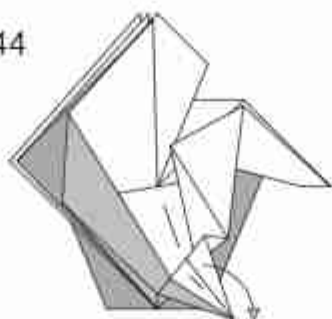

Unfold:

45

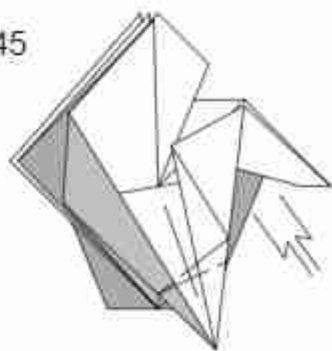

Crimp fold in and out:

46

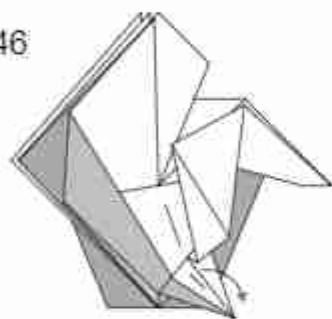

Pull out the edge:

47

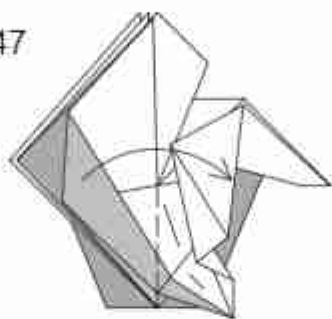

Valley fold:

48

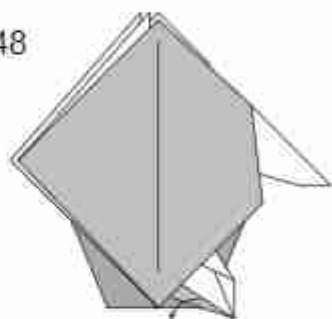

Pull out the raw edge:

49

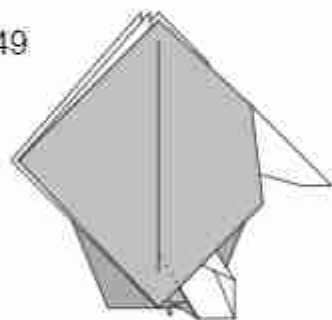

Mountain fold:

50

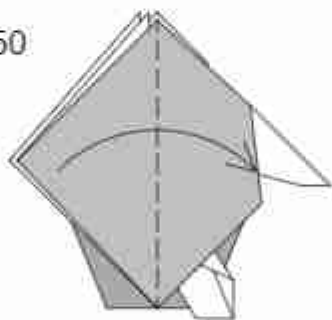

Repeat steps 36 to 49 on the left:

51

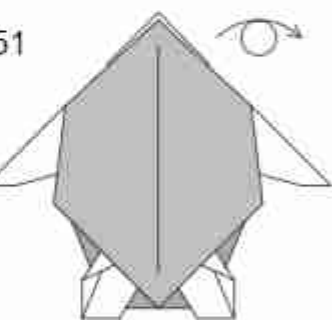

Turn over:

52

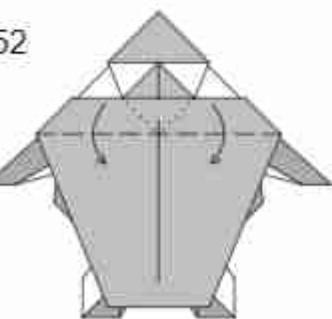

Squash fold through all layers:

53

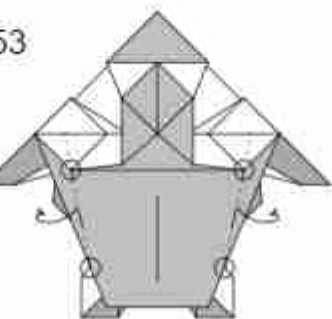

Mountain folds:

54

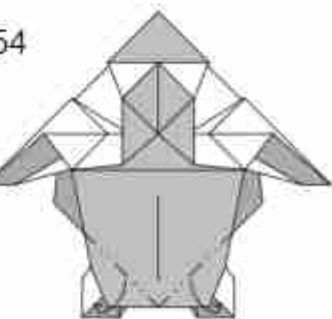

Mountain fold into the pocket:

55

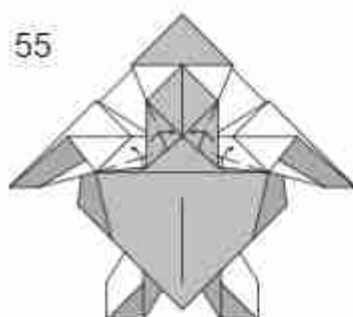

Swivel folds.

56

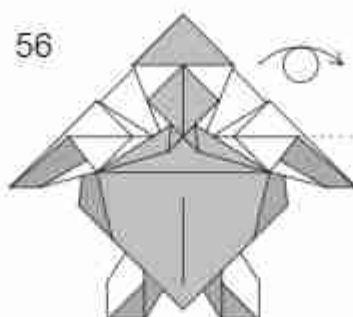

Turn over.

57

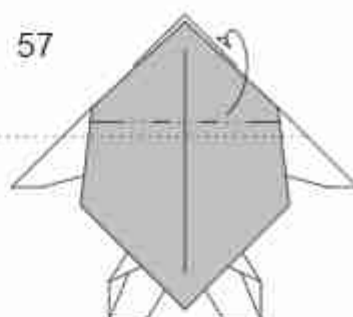

Mountain fold.

58

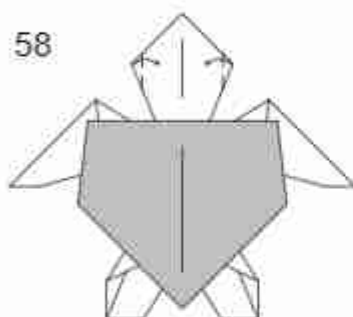

Valley folds.

59

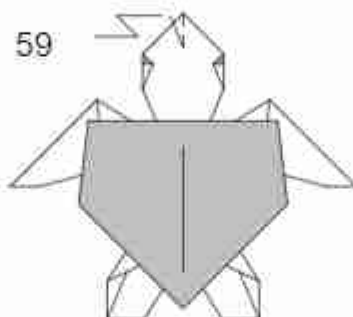

Pleat fold to round the head.

60

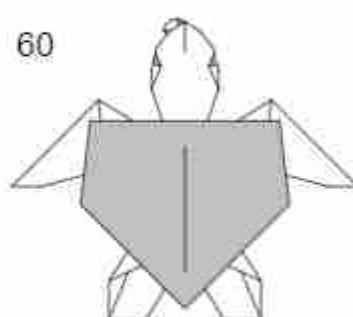

Mountain fold to lock the tip.

61

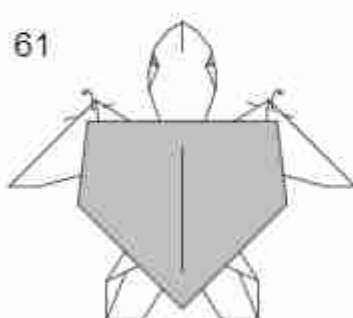

Mountain folds.

62

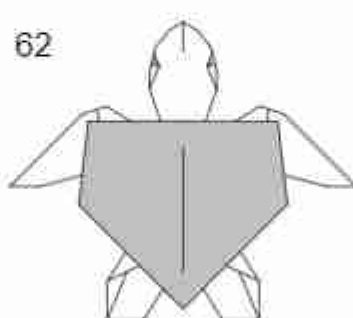

Now you can decide how you want to shape the shell from here...

63

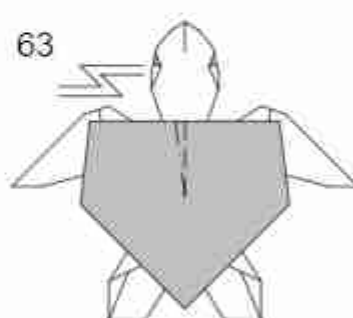

Pleat fold. The shell will not lie flat.

64

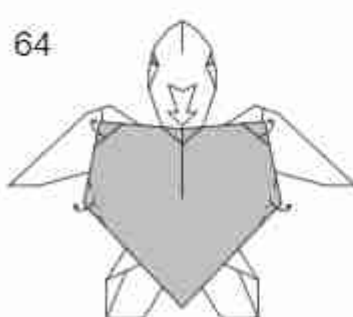

Shape the shell.

65

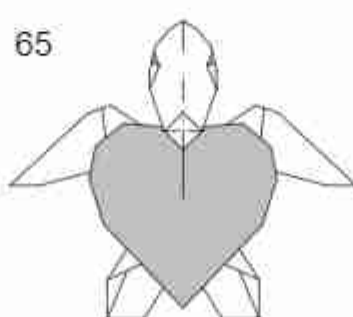

Tilt the head up.

66

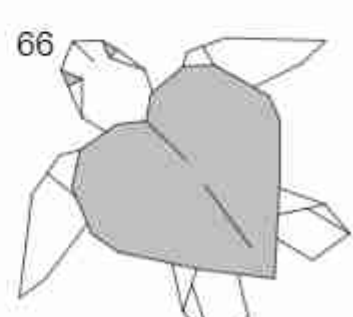

Turtle love.

Christmas Knot

Xiao Yao

©2022 - China

High Intermediate

设计 / 图示: 迷途丸子
Designer / Diagram: Xiao Yao

整形 / model: 空想 / kōngxiǎng

推荐用纸 / Paper:
- 24*24 cm

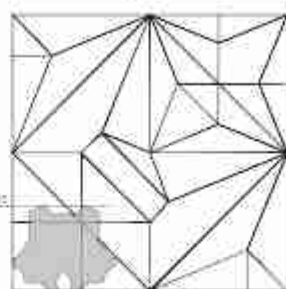

-
-
-
-
-
-
-
-
-

10

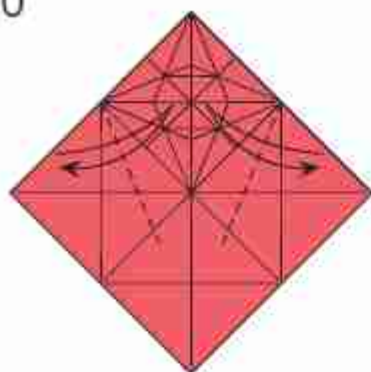

11

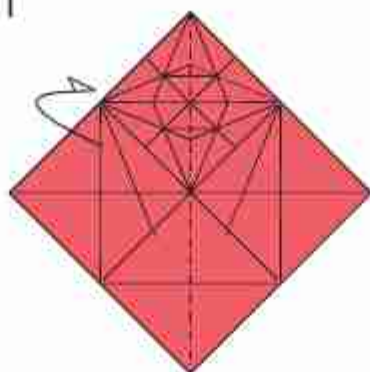

12

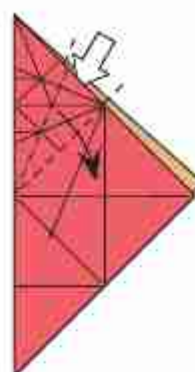

Open and flatten.
撑开压平

13

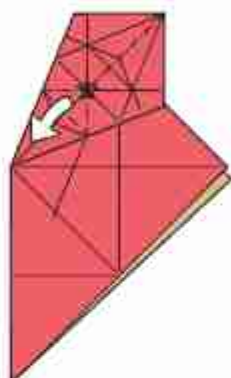

Pull up the point marked with ☆
将☆标注的点顶出

14

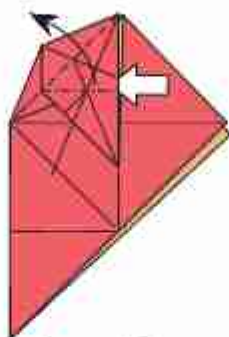

Open and flatten:
撑开压平

15

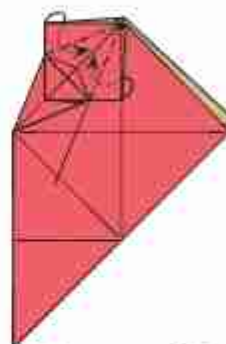

Inside reverse folds.
内翻折

16

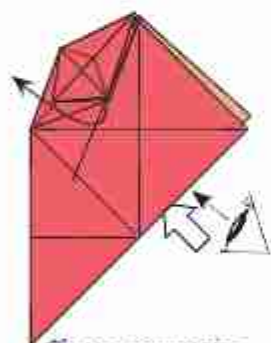

Change perspective.
视角转换

17

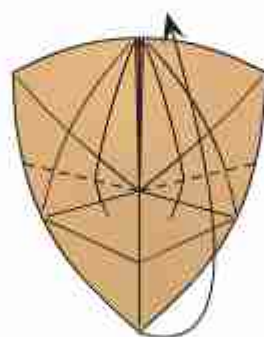

18

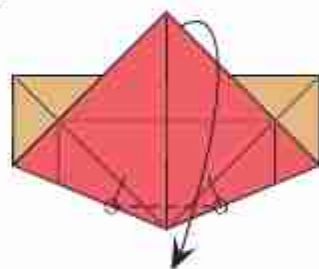

19

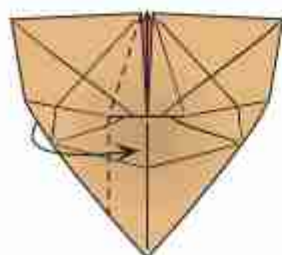

In progress...
Flatten the model.
过程图

20

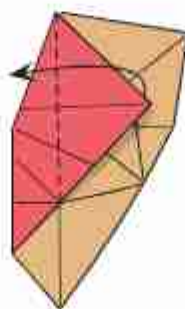

21

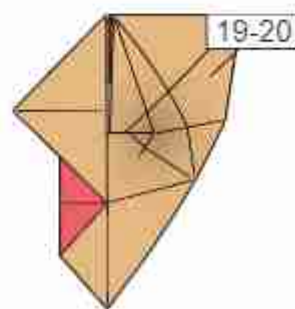

Repeat steps 19-20
on the other side.
对侧重复步骤19-20

22

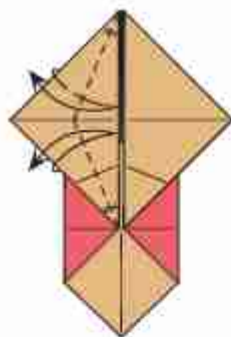

23

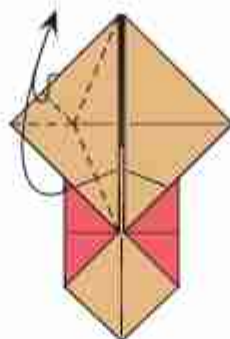

Rabbit-ear fold
兔耳折

24

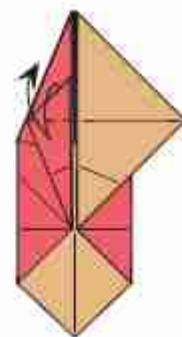

25

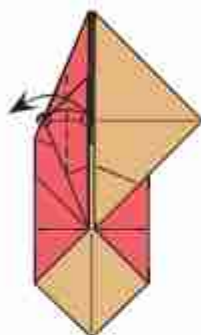

26

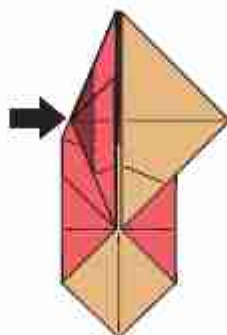

Open sink
开成沉折

27

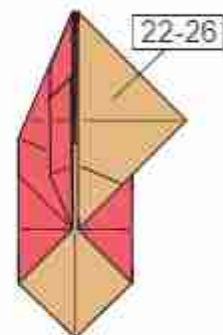

Repeat steps 22-26
on the other side.
对侧重复步骤22-26

28



Open it.
撑开

29

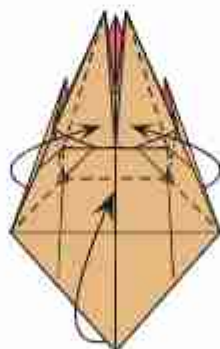

In progress...
Flatten the model.
过程图

30

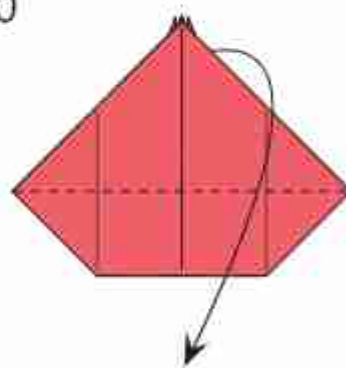

31

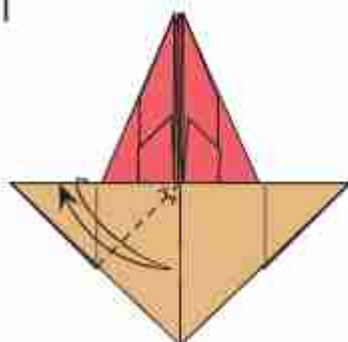

32

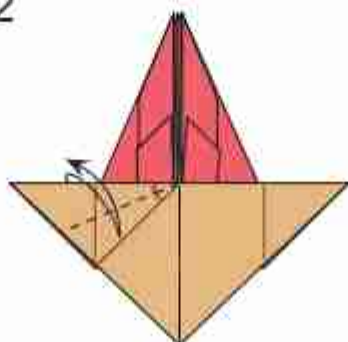

33

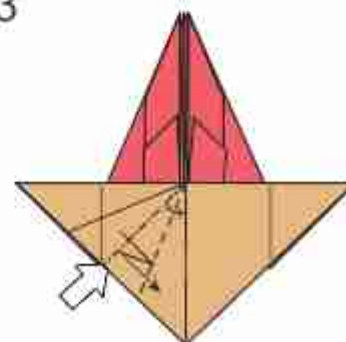

Pleat fold.
皱折

34

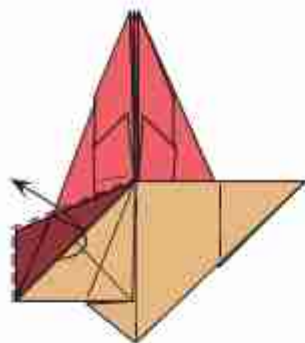

Adjust the paper layer.
拉出紙層,調整順序

35

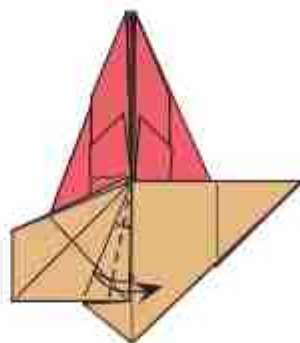

36

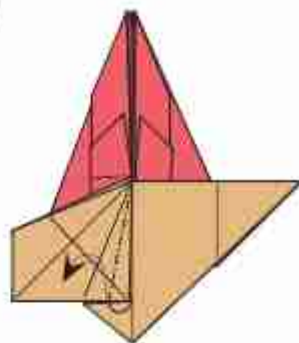

Swivel and flatten.
向內旋轉折壓平

37

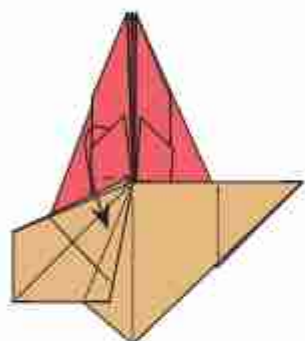

38

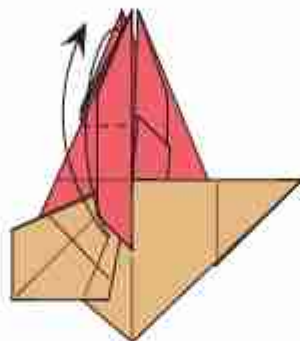

39

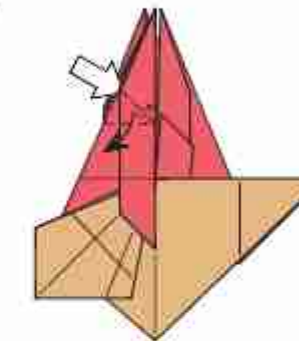

Open and flatten.
撐開壓平

40

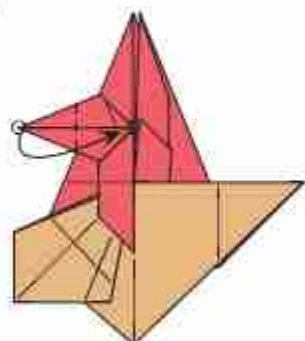

41

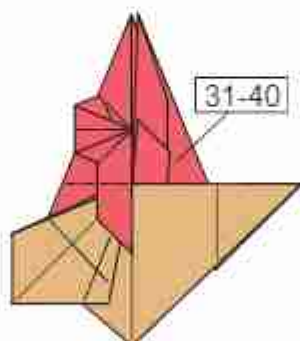

Repeat steps 31-40
on the other side.
對側重復步驟31-40

42

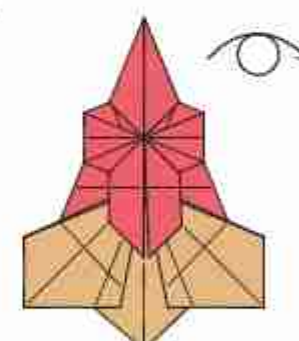

Turn over.
翻面

43

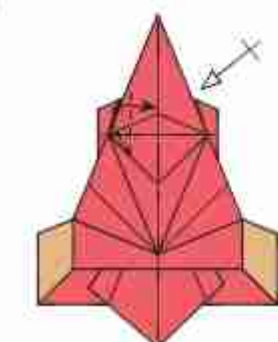

Spread sink the darkened area.
延展沉折

44

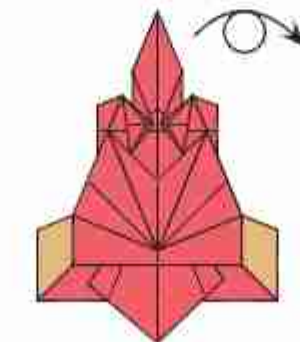

Turn over.
翻面

45

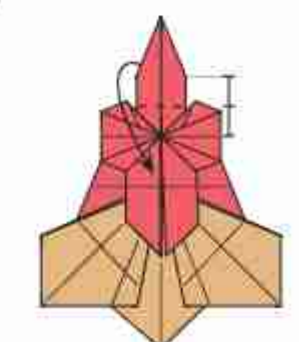

46

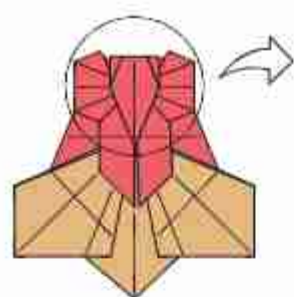

Zoom in
视图局部放大

47

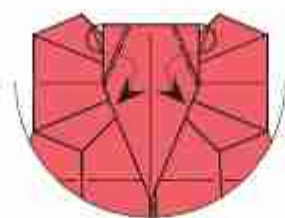

Inside reverse folds
内翻折

48



49

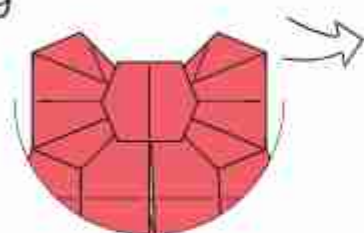

50

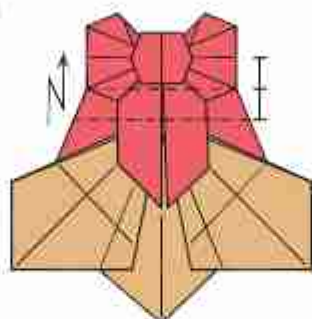

Pleat fold
段折

51

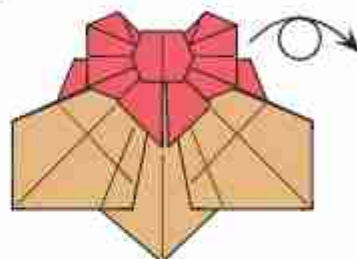

Turn over
翻面

52

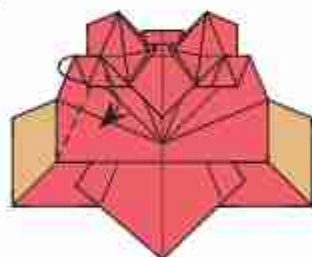

Swivel and flatten
向内旋转段折压平

53

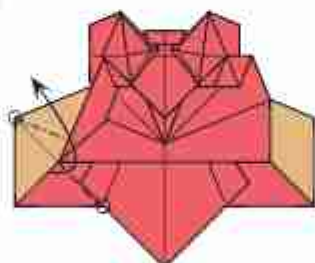

Swivel fold
旋转折压平

54

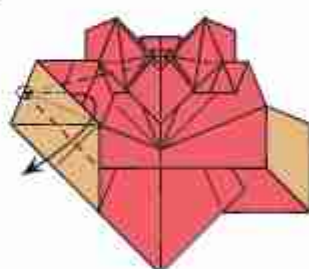

Swivel fold
旋转折压平

55

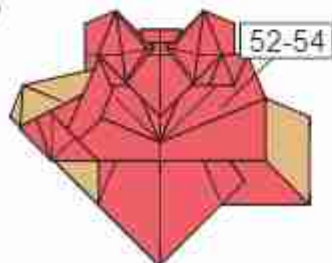

Repeat steps 52-54
on the other side
对侧重复步骤52-54

56

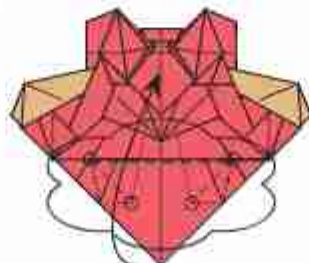

Perspective perspective,
petal-fold
花瓣折

57

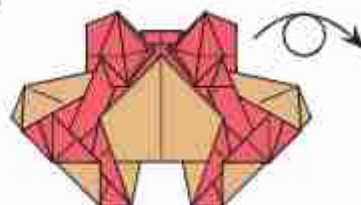

Turn over
翻面

58



Fold the flap up.
向上合折1层

59

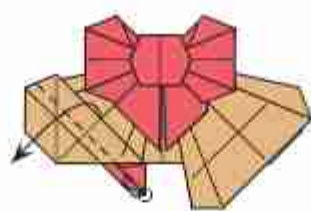

60

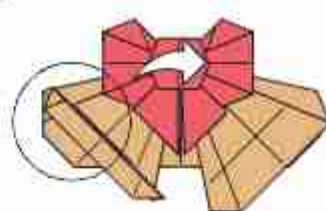

Zoom in.
视图局部放大

61

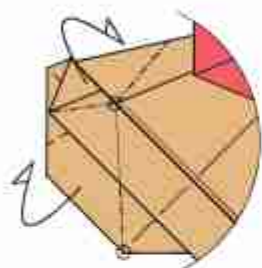

Swivel and flatten.
向后旋转并折压平

62

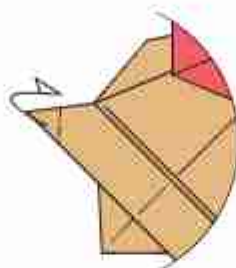

63

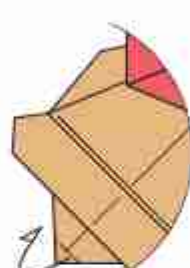

64

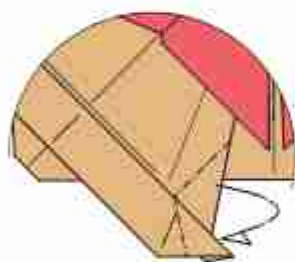

Swivel and flatten.
向后旋转并折压平

65

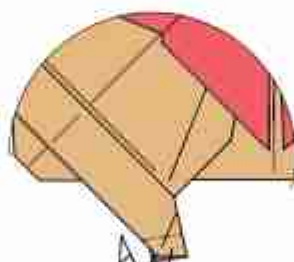

66

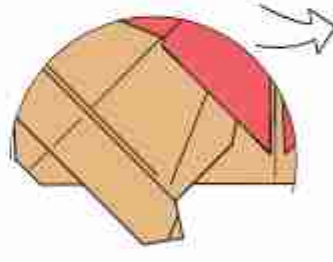

67

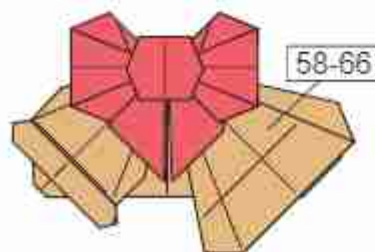

Repeat steps 58-66
on the other side.
对面重复步骤58-66

68



3D Shape the model.
立体整形

69



Complete!
完成!

Envelope

William Zicker

©2021 - USA

Simple

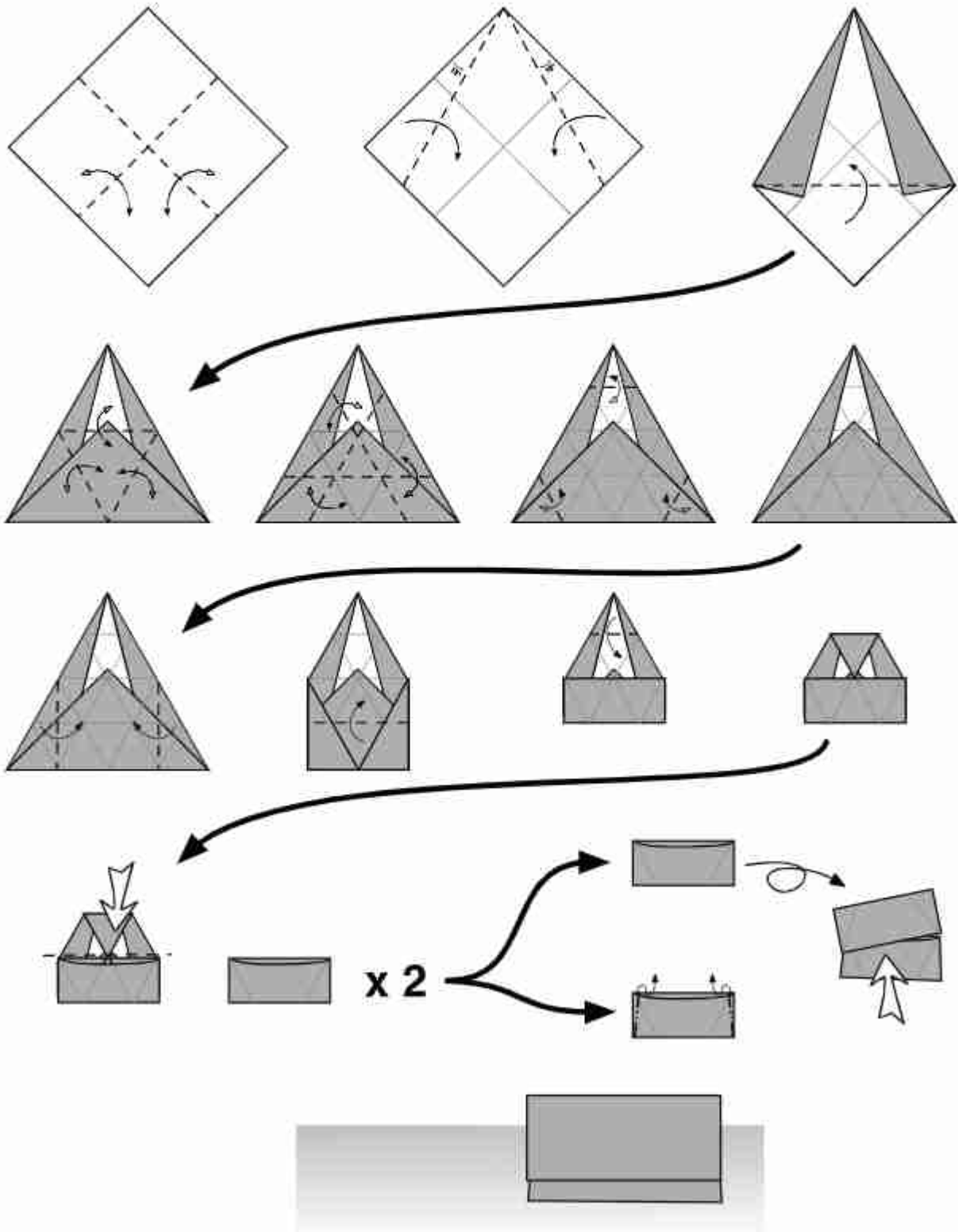

Two-Tone Star

Evan Zodl

©2022 - USA

Low Intermediate

This model is folded from 8 square sheets of duo paper.
3" (7.5cm) squares are recommended.

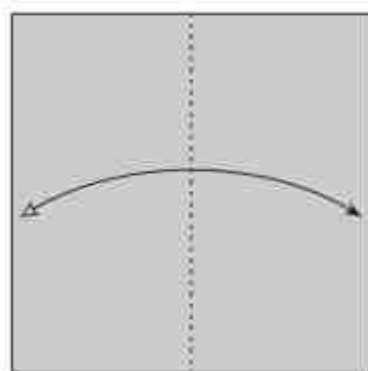

1. Begin with the colored side up.
Fold and unfold. Turn over.

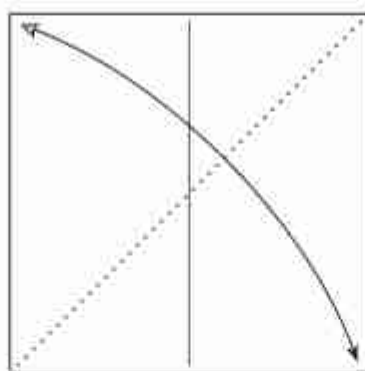

2. Fold and unfold.

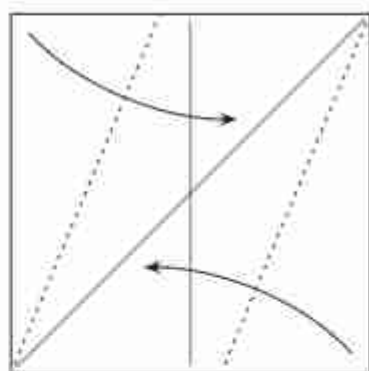

3. Align two edges with the existing diagonal crease.

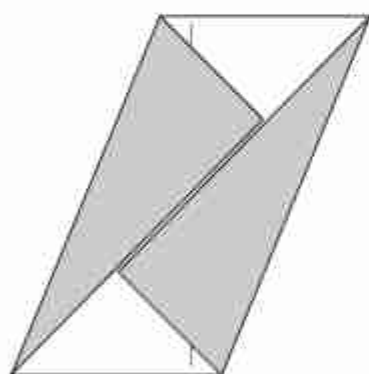

4. The result. Turn over from top to bottom.

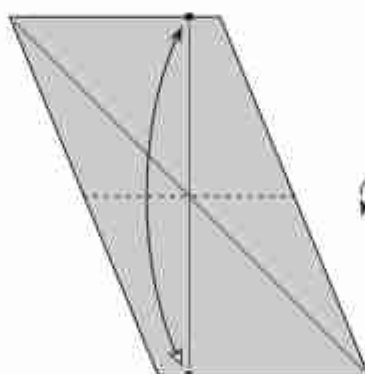

5. Fold and unfold. Rotate.

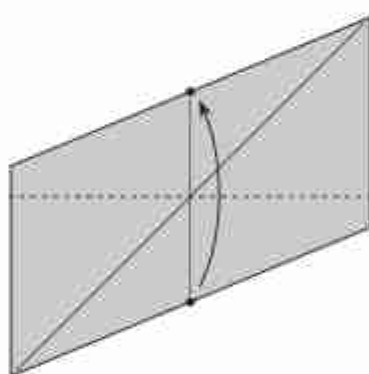

6. Fold in half along an existing crease. Release the trapped layer from underneath.

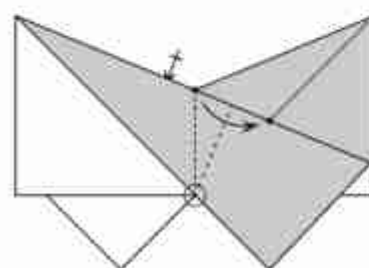

7. Swivel-fold the top group of layers. Repeat behind.

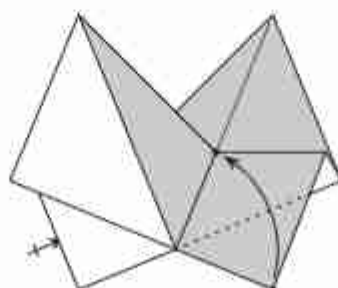

8. Fold the bottom corner to the intersection. Repeat behind.

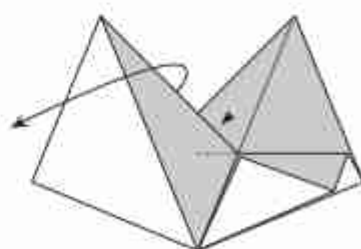

9. Unfold the top group of layers along the crease made in step 7. The model will not lie flat.

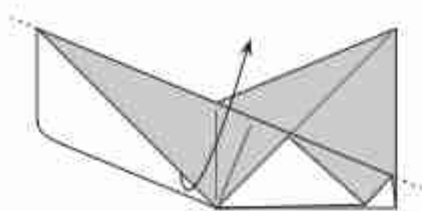

10. Unfold the top layer along an existing crease.

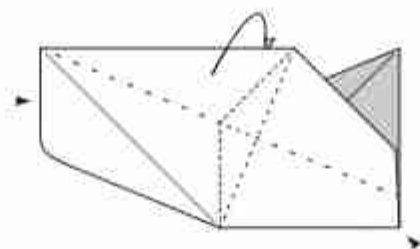

11. Collapse along existing creases.

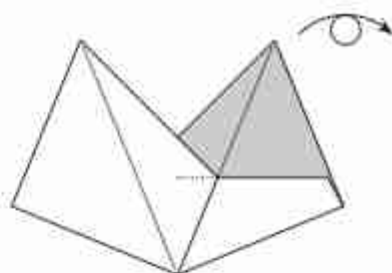

12. The result. The model will now lie flat. Turn over.

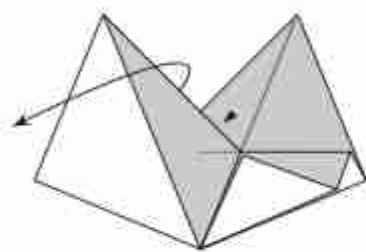

13. Repeat steps 9 - 11 on this side.

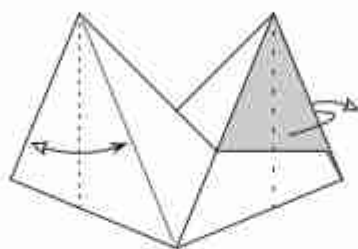

14. Fold and unfold.

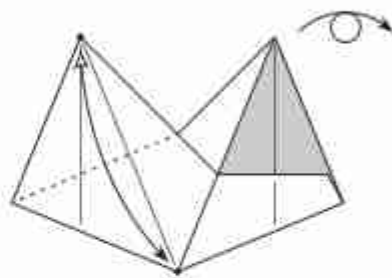

15. Valley-fold and unfold. Turn over.

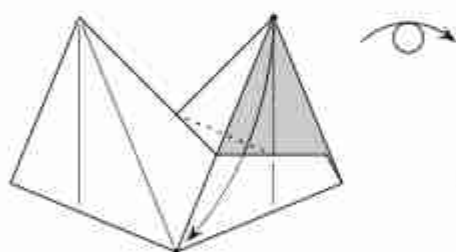

16. Valley-fold along the crease made in the previous step. Tuck the flap inside the pocket. Turn over.

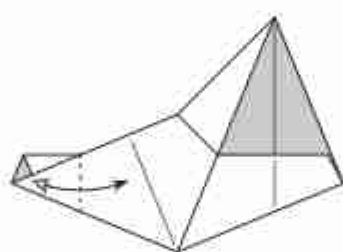

17. Fold and unfold to reinforce an existing crease.

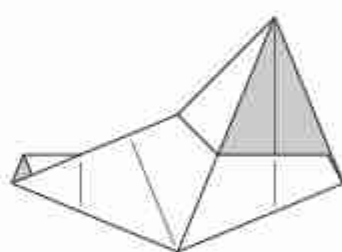

18. Completed unit.

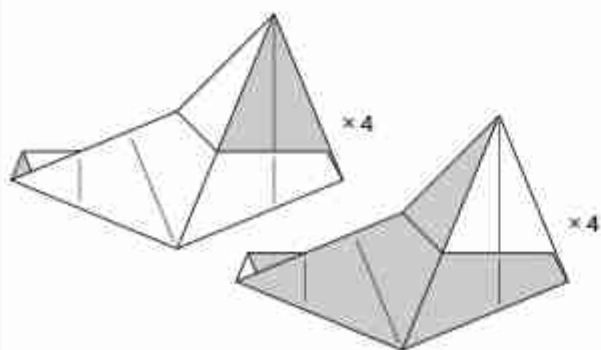

19. Fold four units with the colored side up and four units with the white side up for a total of eight units.

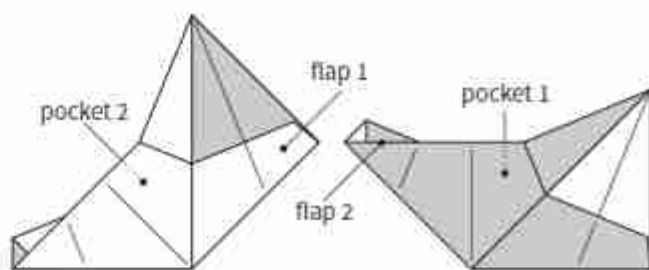

20. Before the assembly, position two units of opposite colors as shown and identify the flaps and pockets.

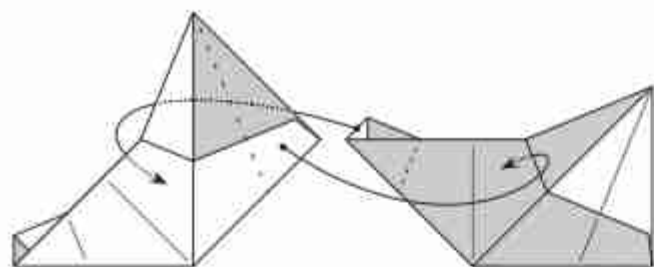

21. Reinforce the creases made in steps 14 and 17 to lock the units together.

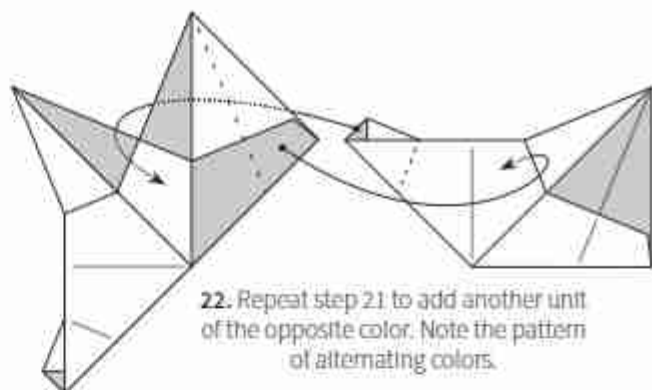

22. Repeat step 21 to add another unit of the opposite color. Note the pattern of alternating colors.

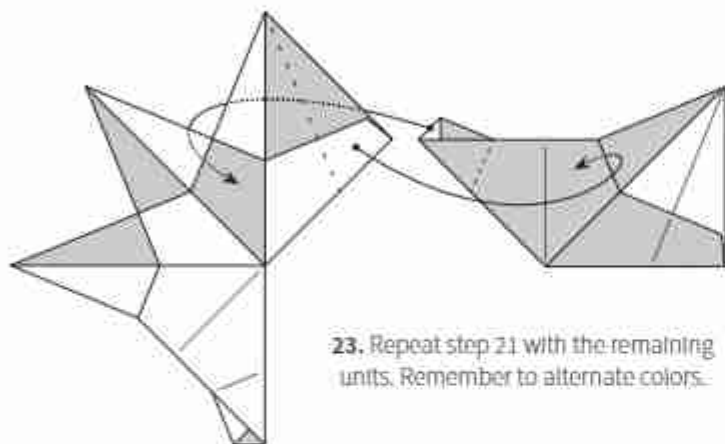

23. Repeat step 21 with the remaining units. Remember to alternate colors.

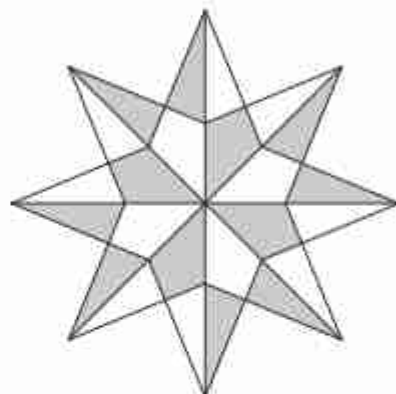

24. Completed Two-Tone Star.

Origami

Basics

Line Styles

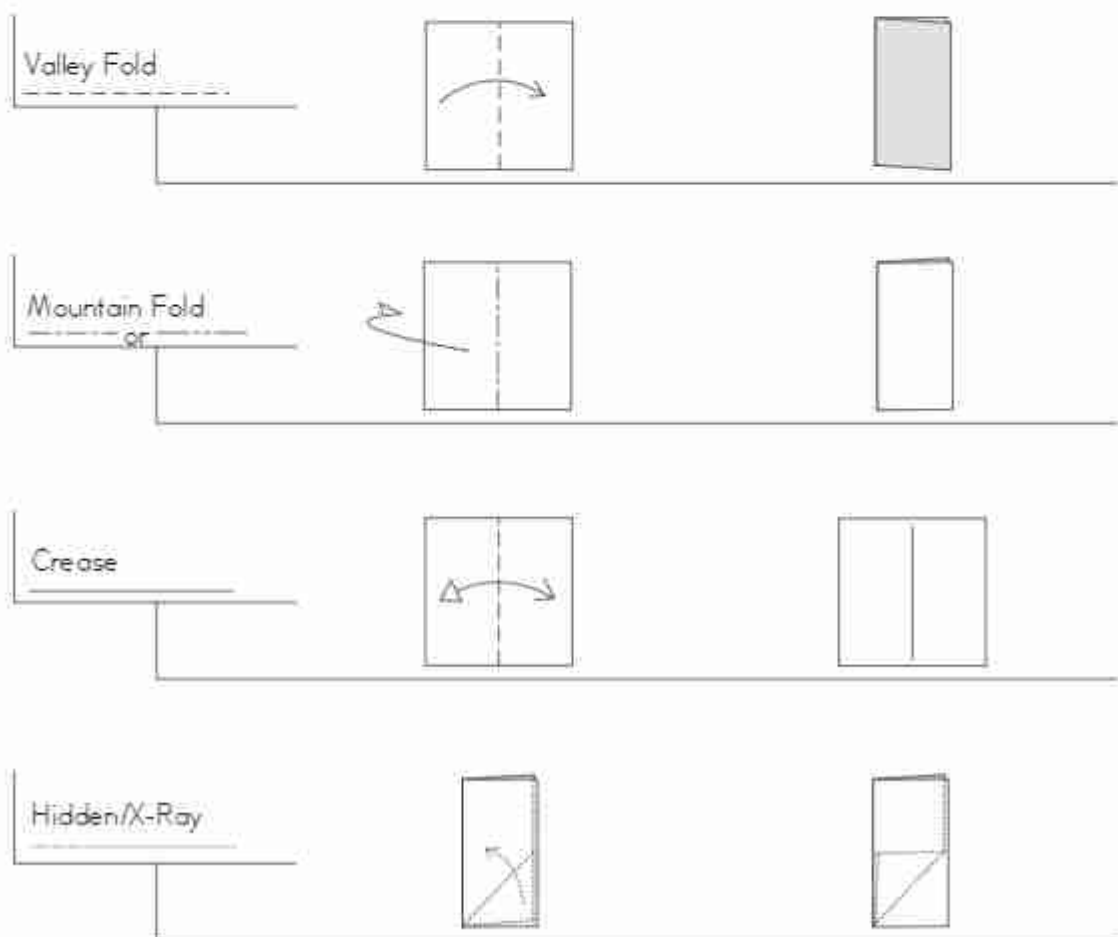

Arrows

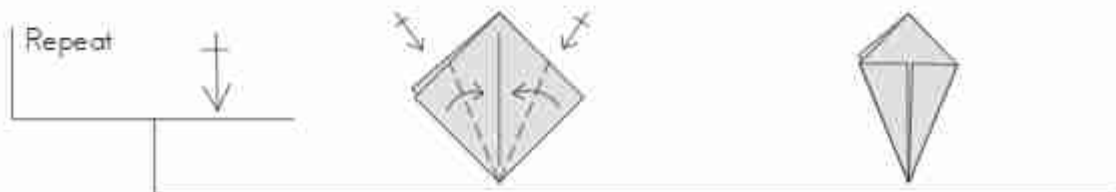
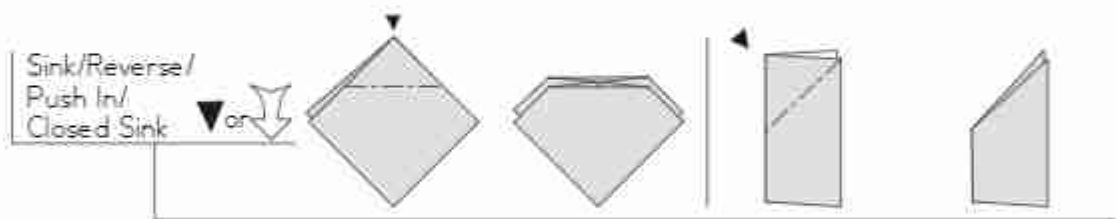
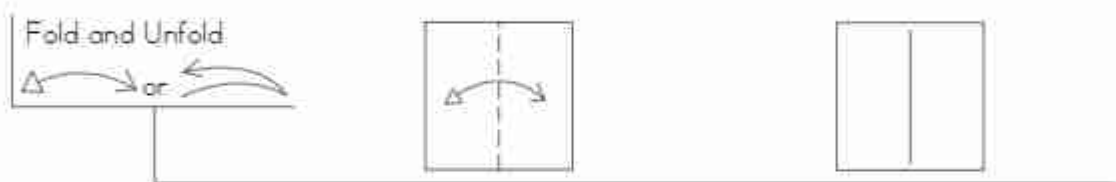
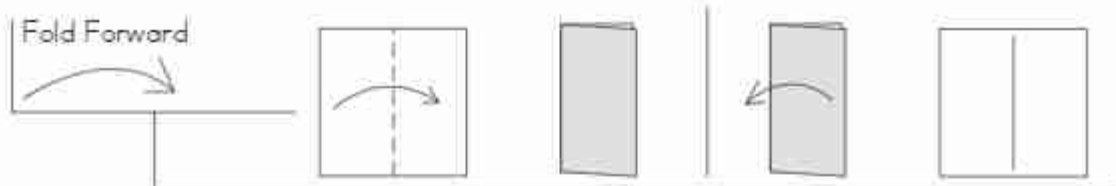

Maneuvers

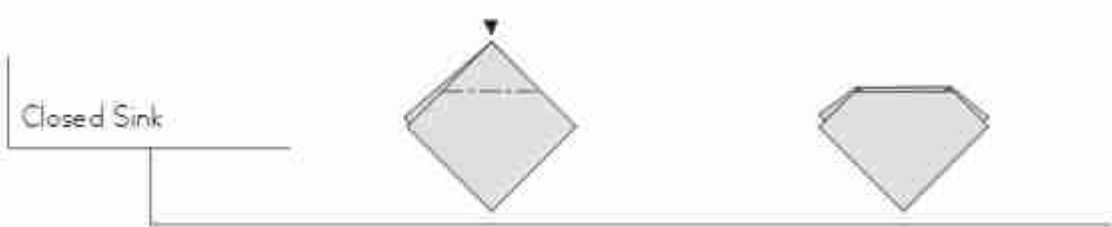
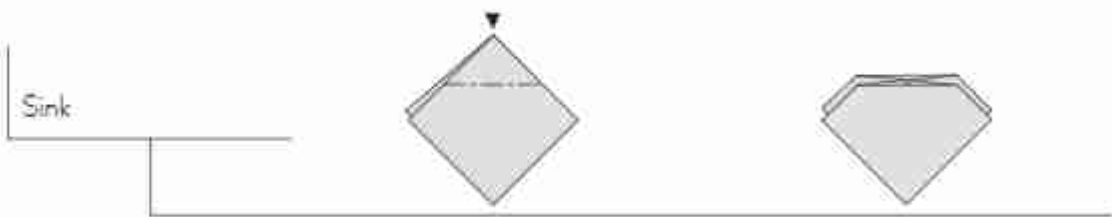
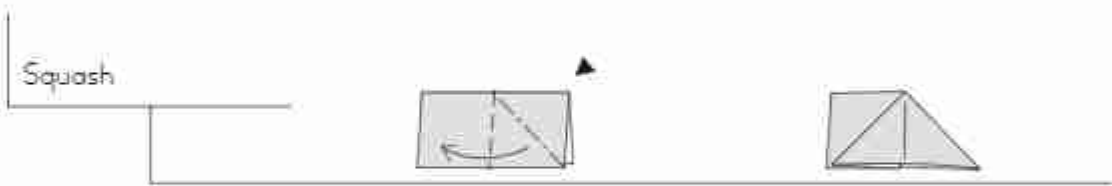
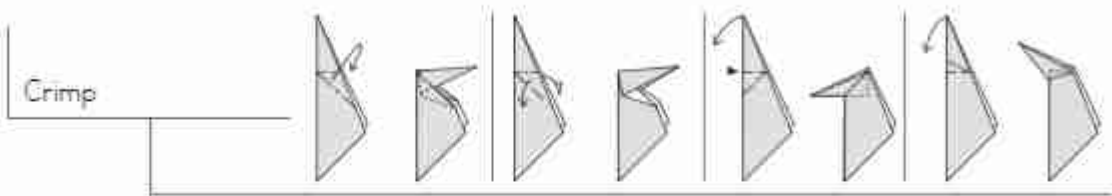

Common Bases

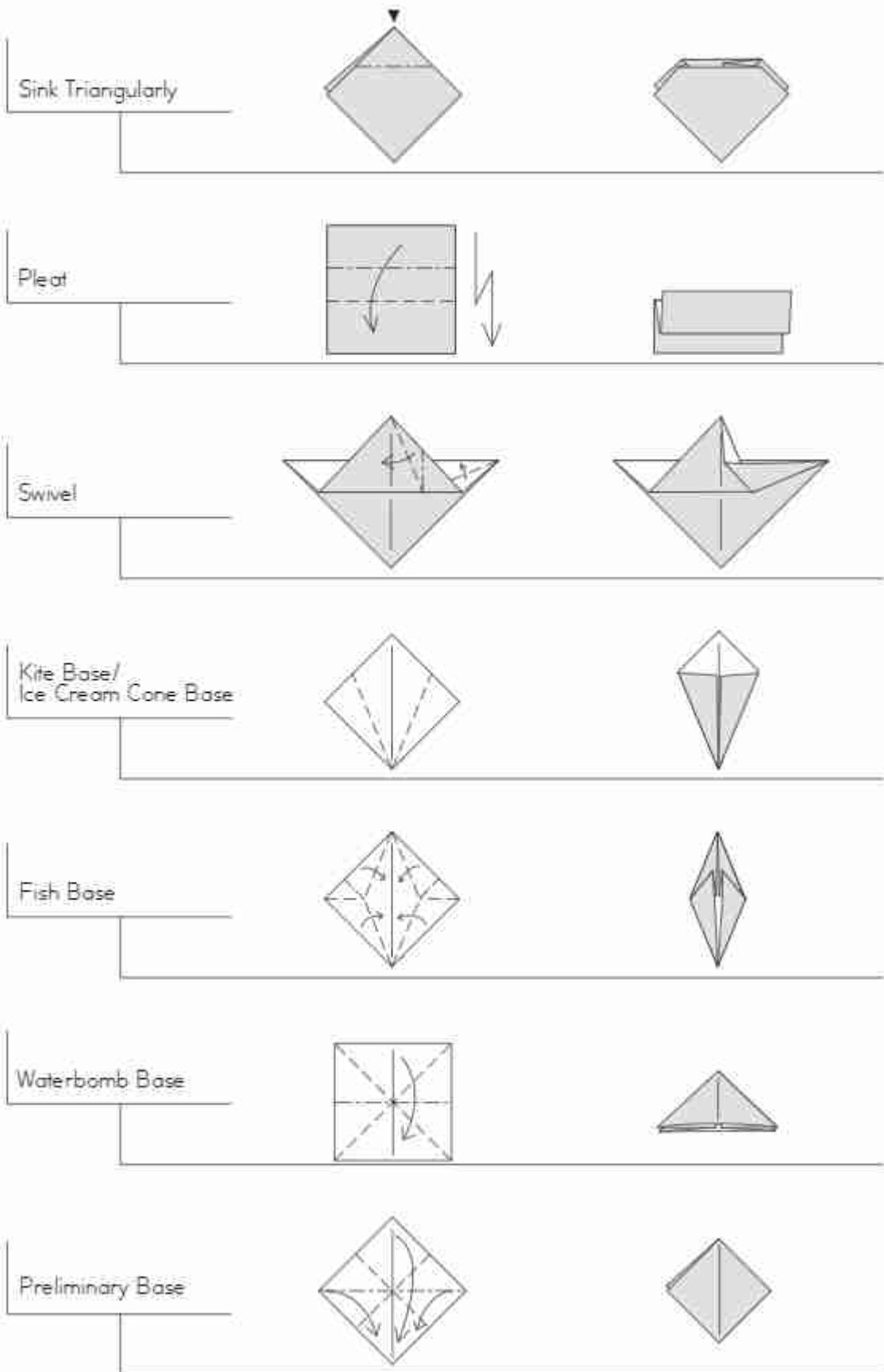

Bird Base

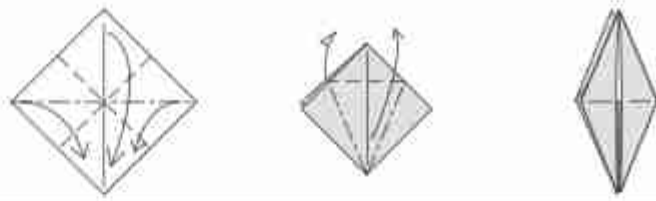

Frog Base/Lily Base

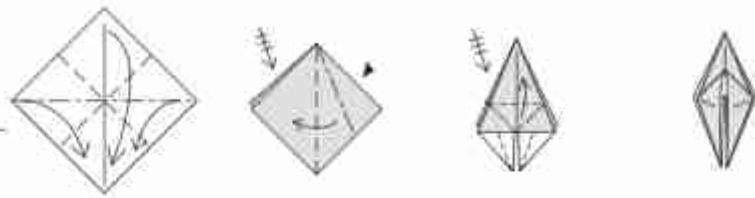

Windmill Base



Stretched Bird Base

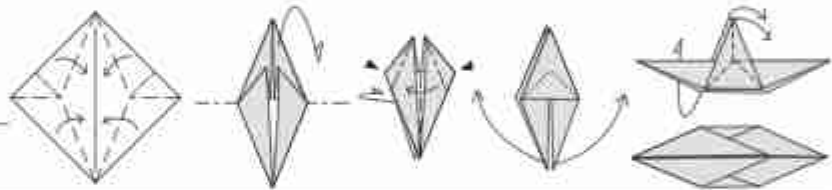

Blintzed Bird Base

