

OrigamiUSA

Origami Collection 2023



Origami Collection 2023

Copyright 2023 by OrigamiUSA, a volunteer-based, not-for-profit educational arts organization committed to the elucidation and dissemination of paperfolding as an art and a craft.

All rights reserved, including the right to reproduce this book or portions thereof in any form without prior written consent.

OrigamiUSA
15 West 77th Street
New York, NY 10024-5192
(212) 769-5635
origamiusa.org

Cover Illustration by Nathan Zeichner

Origami Basics section by Marc Kirschenbaum

Publication Team

Marc Kirschenbaum
JC Nolan
Daniel Scher
Nathan Zeichner

Submissions to the Origami Collection and other OrigamiUSA publications can be sent to origami.usa.pub@gmail.com.

A submission form and copyright guidelines can be found at origamiusa.org/submissions.

Table of Contents

About the Collection	v
Picture Index	vi
The 2023 Origami Collection	1
Origami Basics	216

About the Origami Collection

The *Origami Collection* was born in 1980 from ideals fostered by the founding members of OrigamiUSA. Michael Shall (1949-1995) launched this yearly anthology to share origami models from around the world. His mentor, Lillian Oppenheimer (1898-1992), provided the springboard for this effort, as many of the models were drawn from her collection and connections she cultivated. Alice Gray (1914-1994) also provided inspiration by streamlining the communication of origami ideas. All of the novice-level works in this collection are dedicated to Alice and her love of simple, elegant pieces.

Throughout the years as our presentation has grown more polished, the goal of showcasing great origami has not diminished. The editors of the *Origami Collection* spend many hours curating, testing and editing origami designs to produce a book that will appeal to origami aficionados of all levels and interests. Variety is a key criterion; you will find works here by established origami artists as well as many hidden gems from up-and-coming stars. Most of the pieces are making their debut in these pages. We hope you are as excited about discovering these diagrams as we are in presenting them.

Picture Index



Agrawal, Himanshu
Seated Peacock
Page 1



Berty, Viviane
Crocodile Family in Kimono
Page 19



Arroyo, Manuel
Dollar Bill Horse
Page 5



Berty, Viviane
Pig Family in Kimono
Page 21



Arroyo, Manuel
Sea Turtle
Page 8



Bettens, Christiane
Bidirectional Taro Box
Page 24



Artigas, Jesús
Friend of the Forest
Page 12



Boudias, Christophe
Cat
Page 25

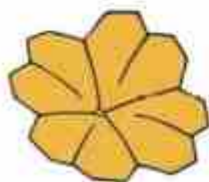

Artigas, Jesús
Sundrop Flower
Page 16



Boudias, Christophe
Orchid
Page 27



Chan, Brian
Apple
Page 28

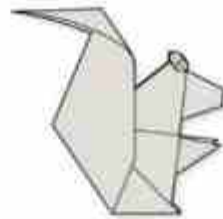

Ellison, Richard
Little Squirrel
Page 44

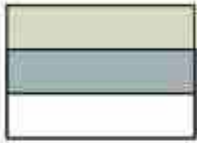

Chen, Sy
Flags with Stripes
Page 30

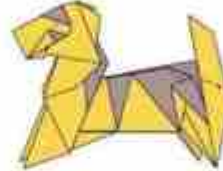

Esteve, Oriol
Tiger
Page 46



Chen, Sy
Three-Unit Direction Dice
Page 33



Garcia, Roger
Witch
Page 51



Clémenson, Paul
Tightrope Walker
Page 35

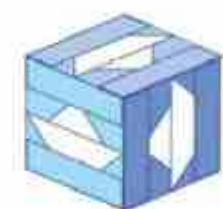

Gupta, Madhura
Boats
Page 55



Ellison, David
Emu
Page 41

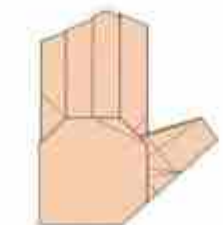

Haag, Bodo
Hand
Page 58



Haag, Bodo
Kangaroo
Page 61



Hudson, Andrew
Mushroom Bookmark
Page 86



Haag, Bodo
Milk Carton
Page 69



Kawamura, Miyuki
Circle Braid
Page 88



Harrington, Kyle
American Hero
Page 73



Kawamura, Miyuki
House
Page 90

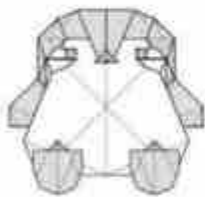

Haruka, Hashimoto
Stuffed Penguin
Page 77



Kawamura, Miyuki
Little Circus
Page 93



Huang, Xiaoxian
Peace and Love
Page 82

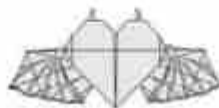

Kenedy, Allan
Winged Heart with Horns
Page 96



Khani, Mahyar Hossein
Windmill Flower
Page 102



Macedo, Jonicley
Shirley Star
Page 124



Kirschenbaum, Marc
Squirrel
Page 106

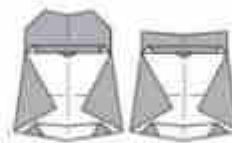

Mariani, Adriano
Rainbow Island Penguins
Page 126

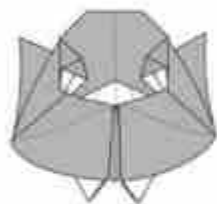

Kobayashi, Hiroaki
Chick
Page 109



Marlina, Linda
Onibi Star
Page 129



Liang, Zhu
Panda
Page 113



Nir, Yossi
Monika 8-Pointed Star
Page 133



Louis, Gareth
Skunk
Page 119



Ortiz, Maximiliano
Mariela Star
Page 137



Peled, Yehuda
Hashmatan
Page 139



Rosemarin, Jane
Pear
Page 158



Pradipta, Rhanu
Stork
Page 144

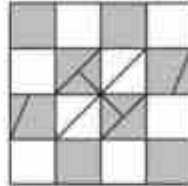

Shafer, Jeremy
Iso-Area 4x4 Checkerboard
Page 160



Pulido, Leonardo
Horse
Page 147

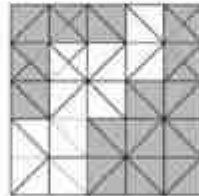

Tahir, Hadi
5x5 Pixel Grid
Page 164



Putranti, Wuri Dyah
Kupu-Kupu Pentafly
Page 152



Tahir, Hadi
Rabbit
Page 167



Qingquan, Li
Sheep
Page 154



Tahir, Hadi
Star
Page 169



Terry, Nicolas
Beaver
Page 171

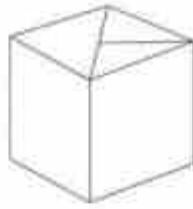

Vilanova, L. Fernandez
One Page Cube
Page 198



Thomas, Ramon
Puppy
Page 182



Vivanco, Javier
Alpaca
Page 199



Versnick, Paula
Freedom
Page 187



Witte, Caleb
Fox
Page 205



Vigier, Eric
Fairy Night 451
Page 189

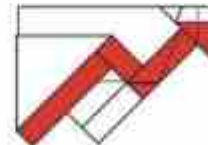

Yao, Xiao
Trendline
Page 208



Vigier, Eric
Torii
Page 196



Youngshin, Jung
Pythagorean Theorem
Page 211

OrigamiUSA

Origami Collection 2023



Seated Peacock

Himanshu Agrawal

©2020 - India

Intermediate

This design is dedicated to my dear friend, Won Seon Seo.

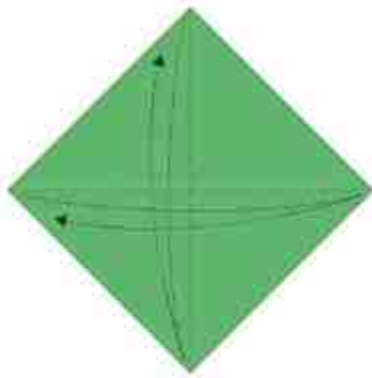

1

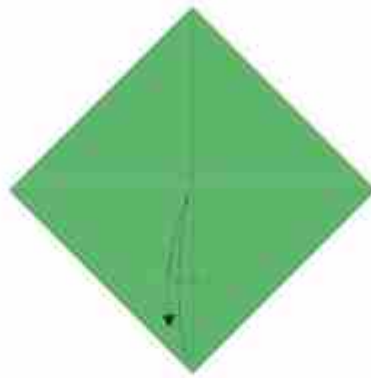

2

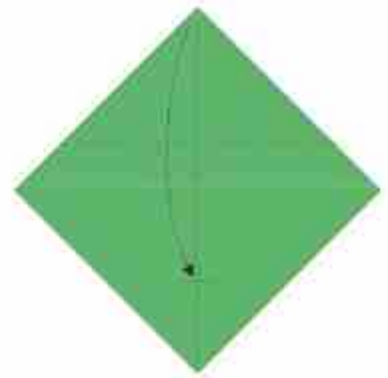

3

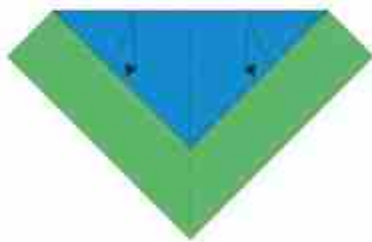

4

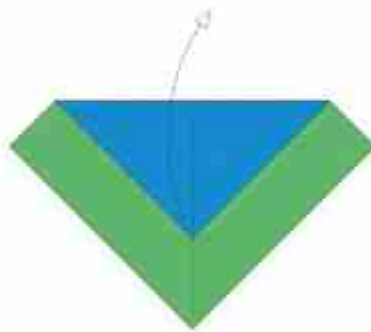

5

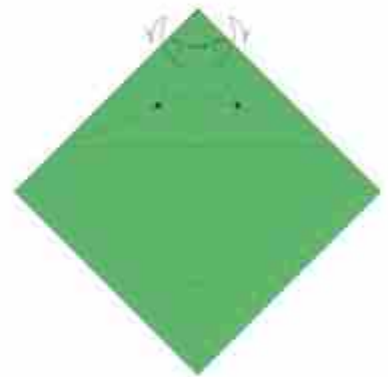

6

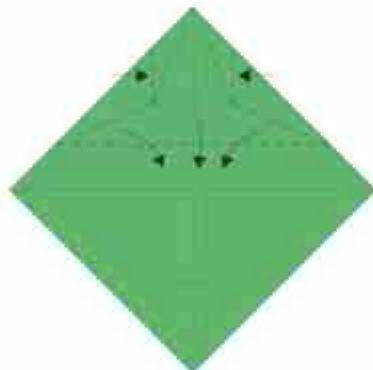

7



8

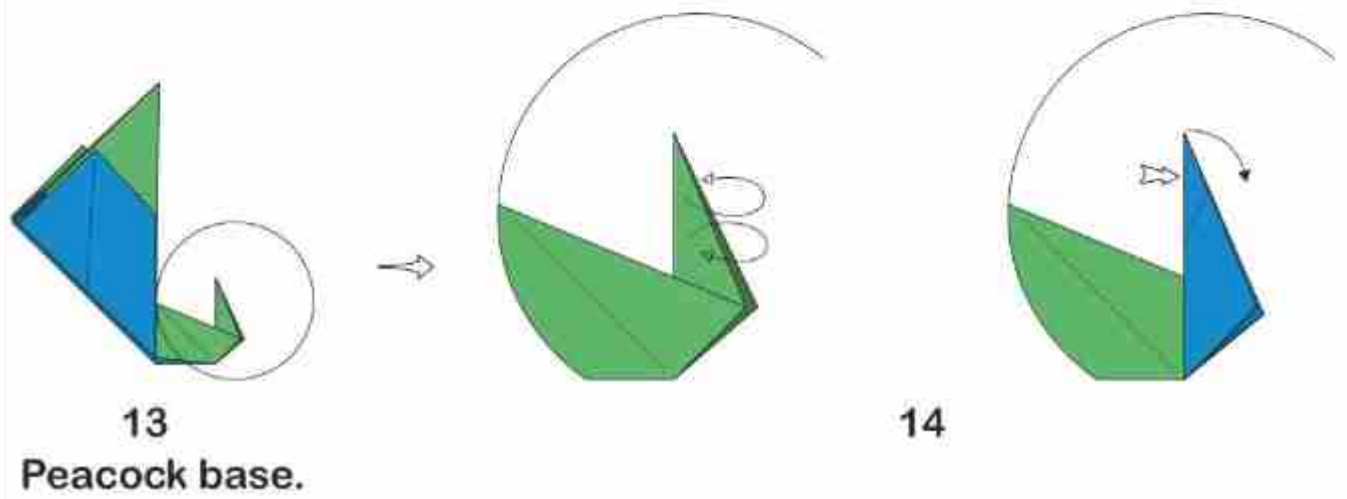
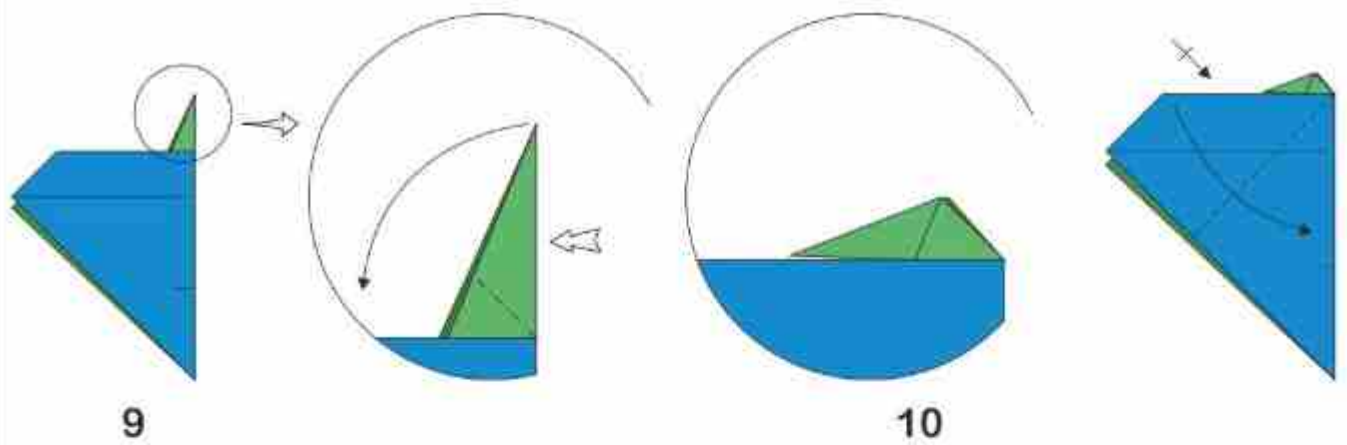

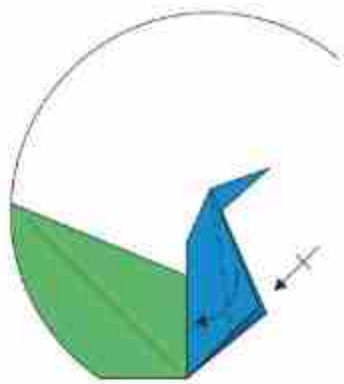

15

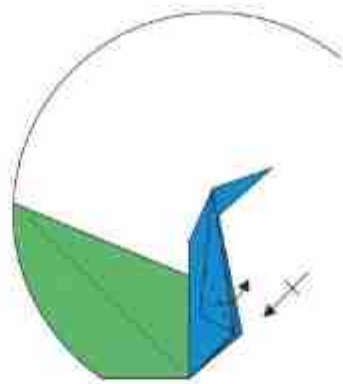

16

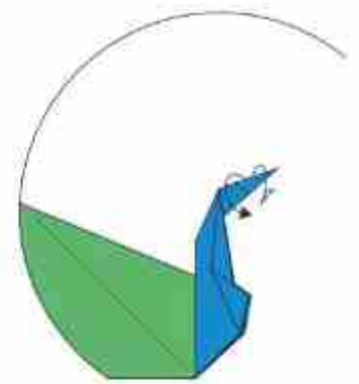

17

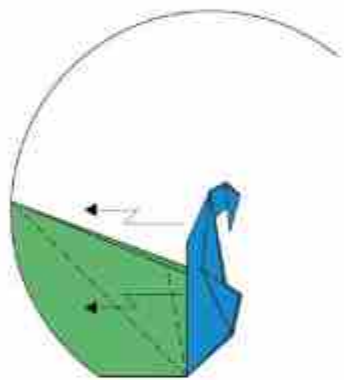

18

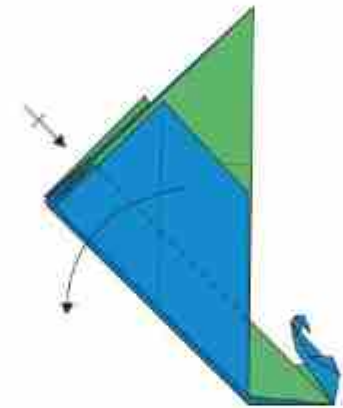

19

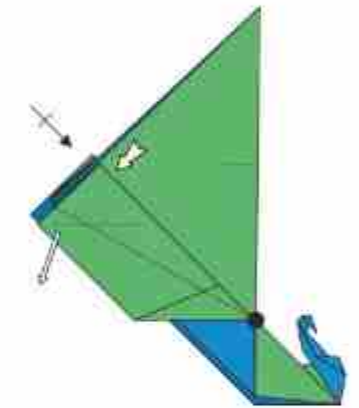

20

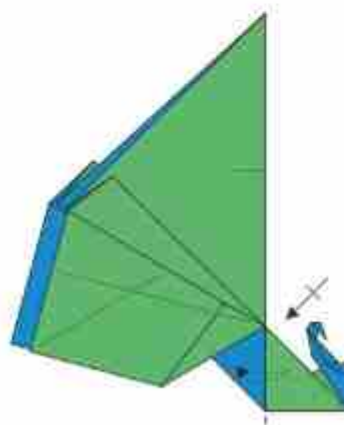

21

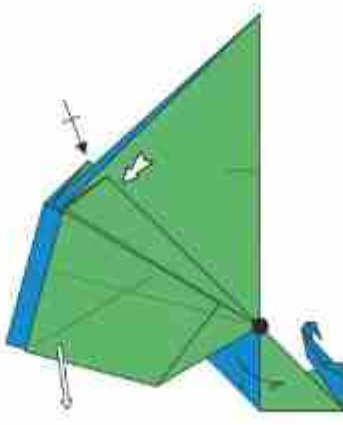

22

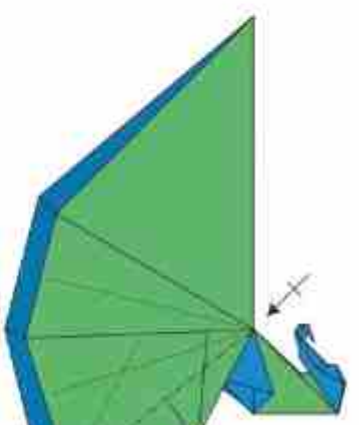

23

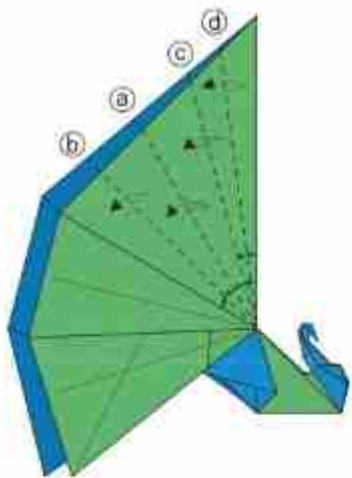

24

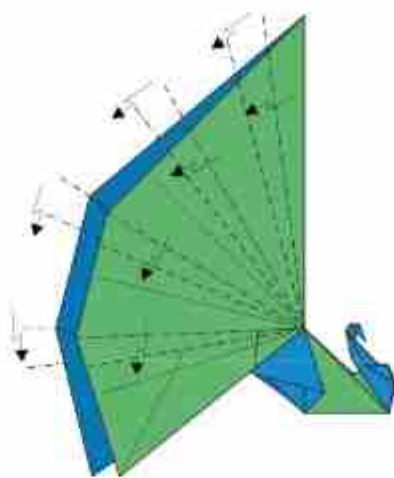

25

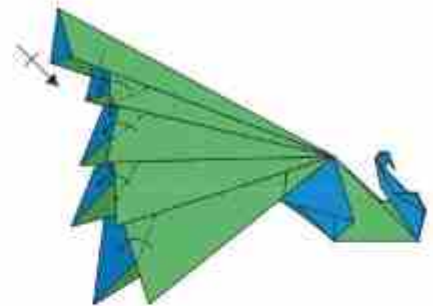

26

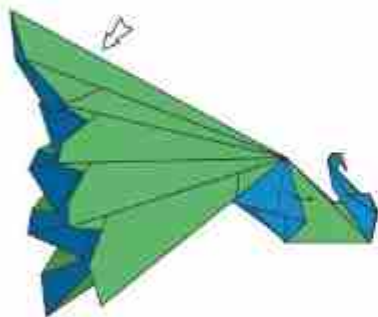

27

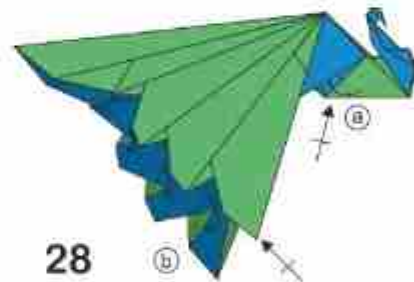

28

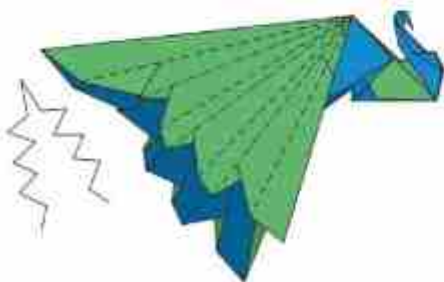

29

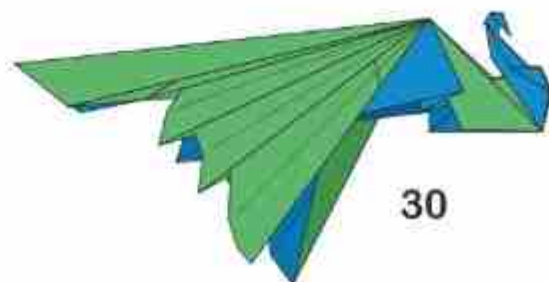

30

Dollar Bill Horse

Manuel Arroyo

©2021 - Spain

Intermediate

① - Posición Dollar



②



③

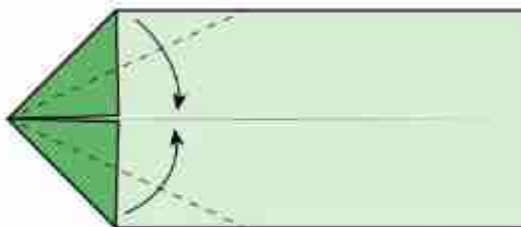

④ - Marcar

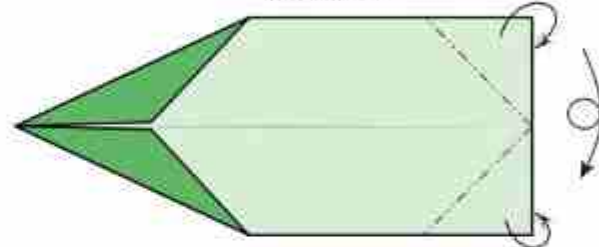

⑤ - Girar y deshacer el paso 4

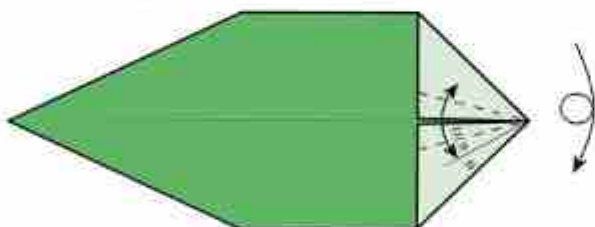

⑥ - Marcar

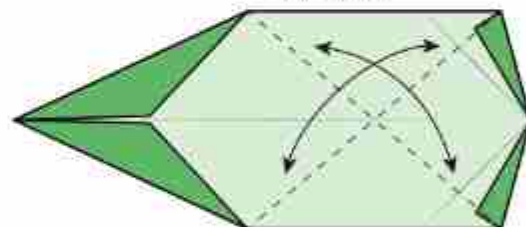

⑦

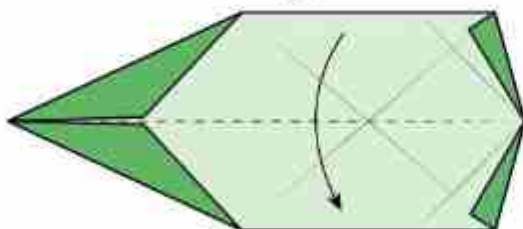

⑧ - Atención referencias

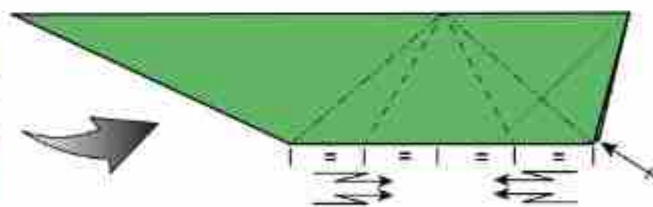

⑨ - Vista interior

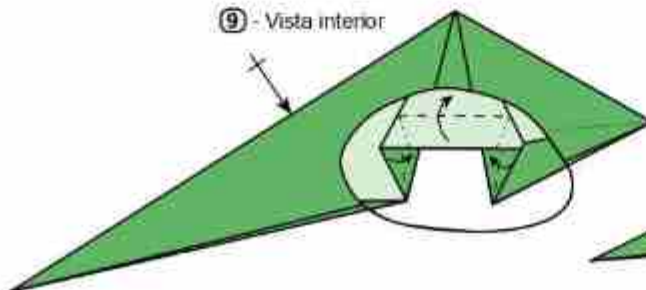

⑩ - Marcar primero

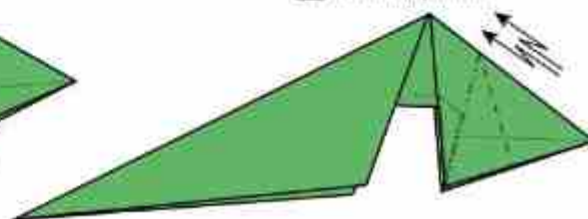

11 - Realizar invertido

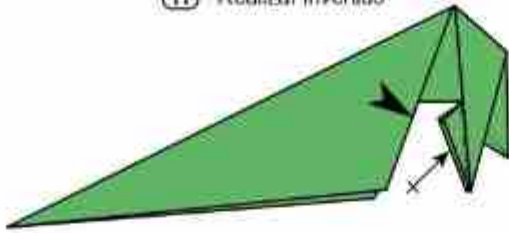

12 - Hundido cerrado



13 - Marcar primero

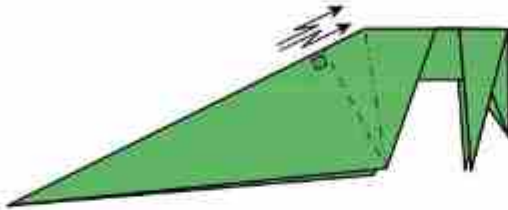

14

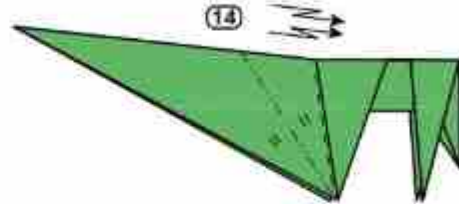

15 - Marcar. Sobrepasa la línea interior

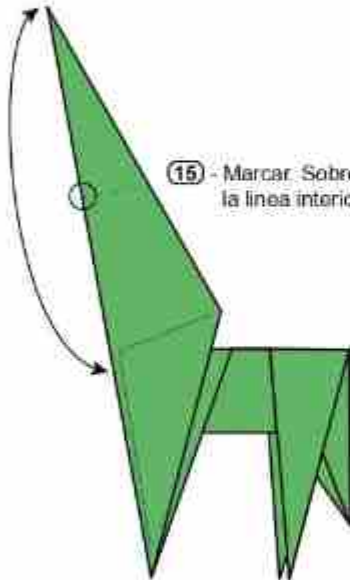

16 - Realizar invertido. Ver paso siguiente



17 - Invertido exterior

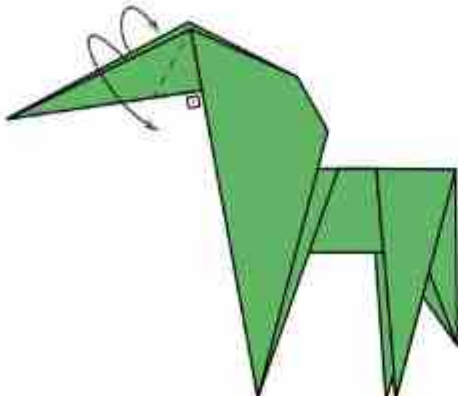

18 - Sacar la capa interior



19



20

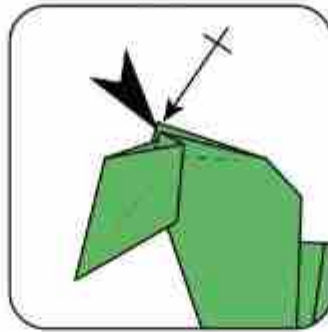

21

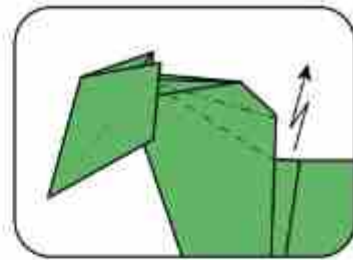

23 - Cabeza en 3D

22

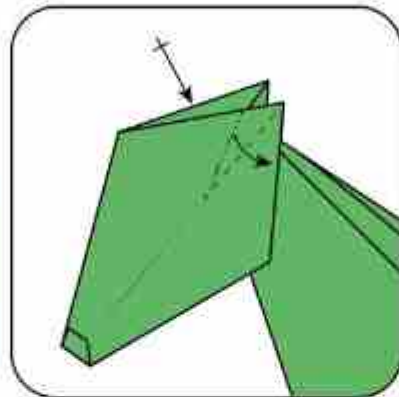
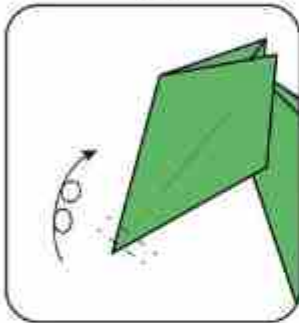

24

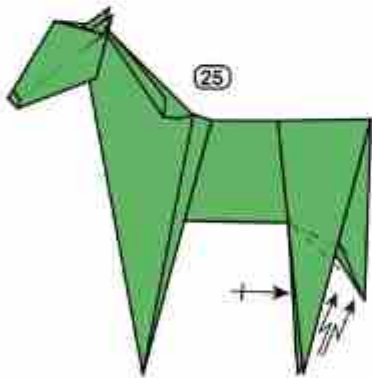
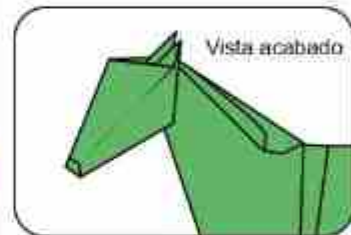

25



26 - Hundido cerrado

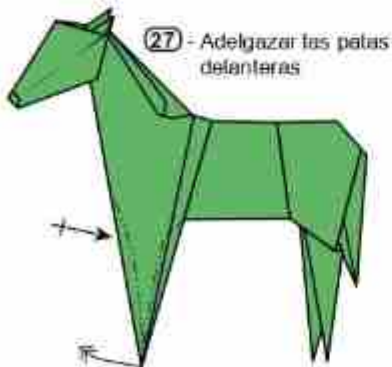

27 - Adelgazar las patas delanteras

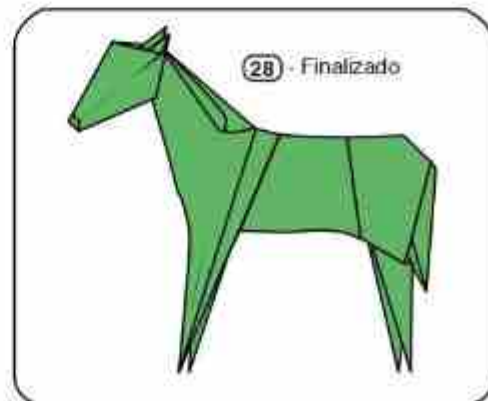

28 - Finalizado

 **Recomendación: papel ≥ 20 cm**

① - Marcar Base Bomba de Agua

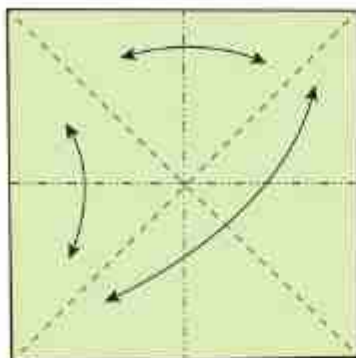

② - Plegar base Bomba de Agua

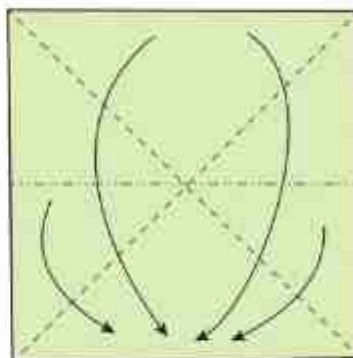

③ - No ajustar el pliegue, dejar más de 2 mm en la punta superior

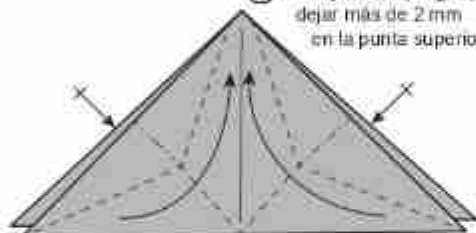

④ - Marcar bien y desplegar

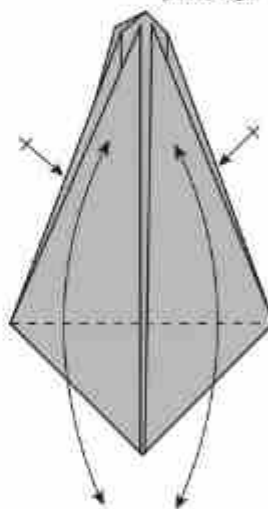

⑤ - Vista preliminar

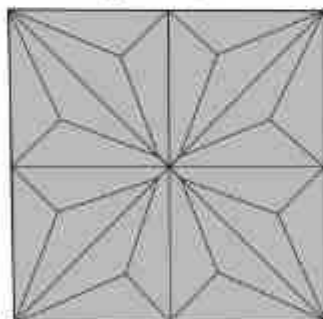

⑥ - Empezar marcando los pliegues en montaña

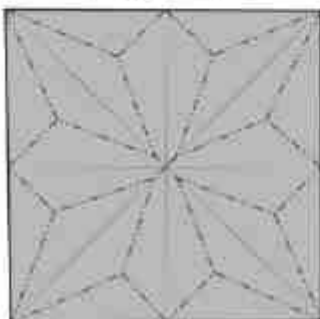

⑦ - Vista y paso preliminar

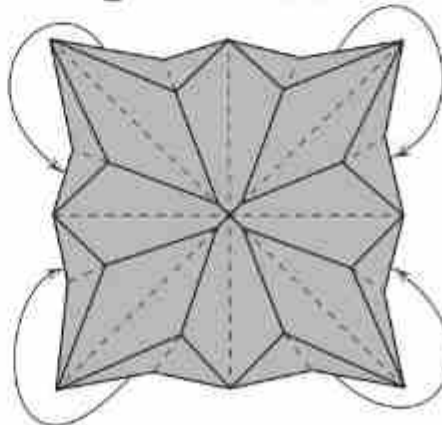

8 - Marcar

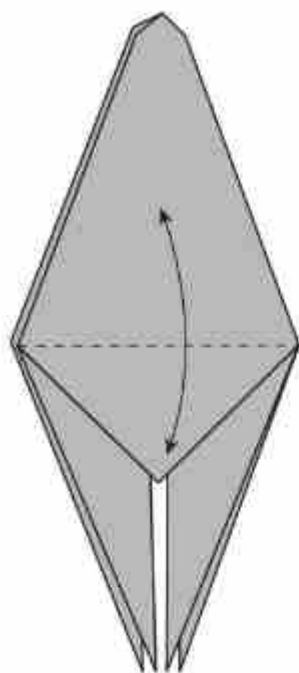

9 - Marcar por las referencias

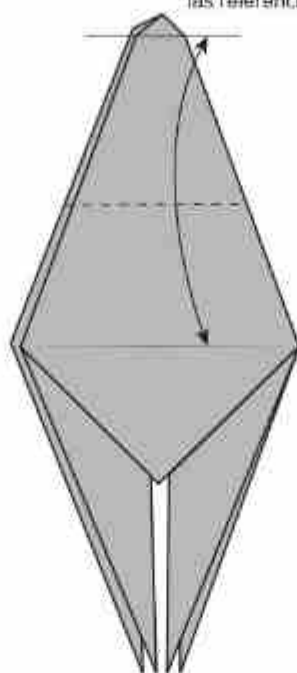

10

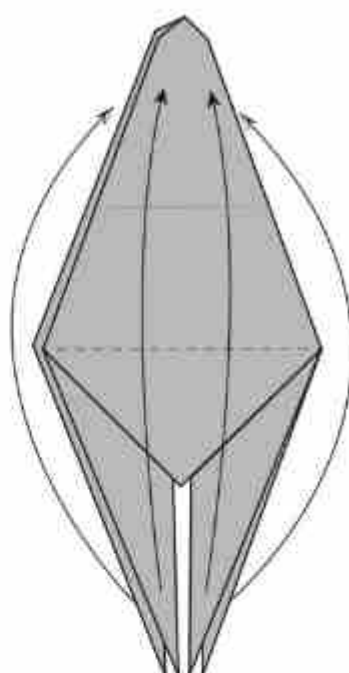

11

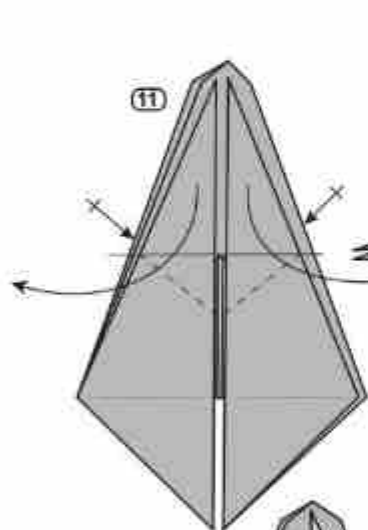

12 - Sacar solo la primera capa y elevar la aleta

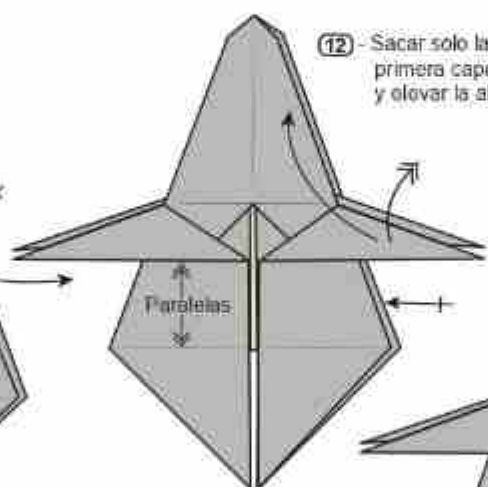

13

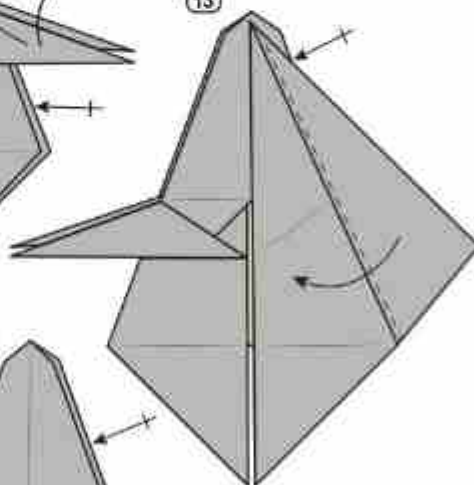

14

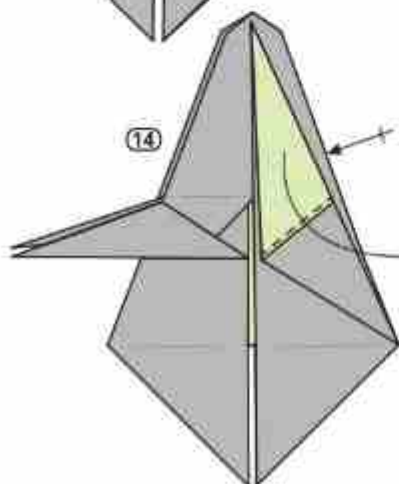

15 - Girar / invertir y cambiar de color la primera capa

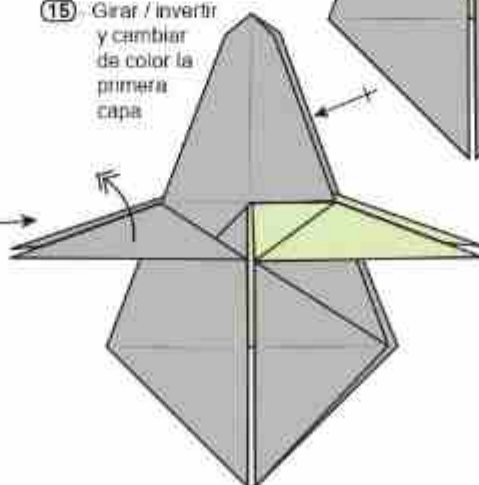

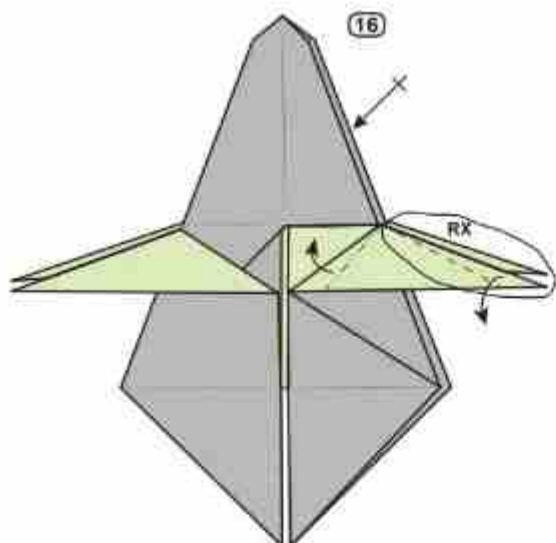

16

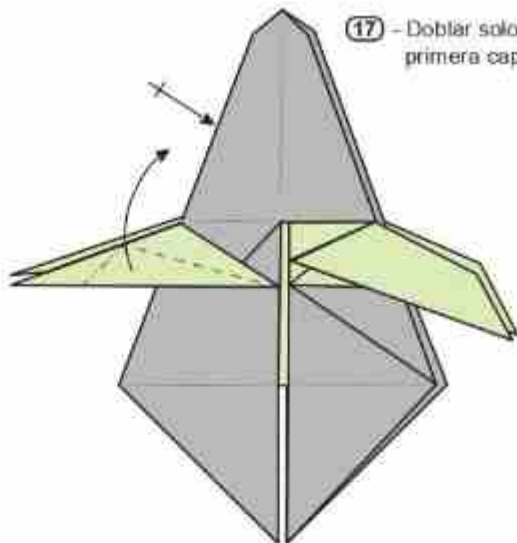

17 - Doblar solo la primera capa

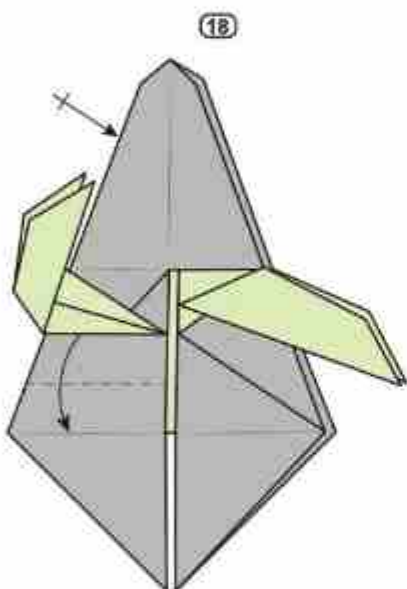

18

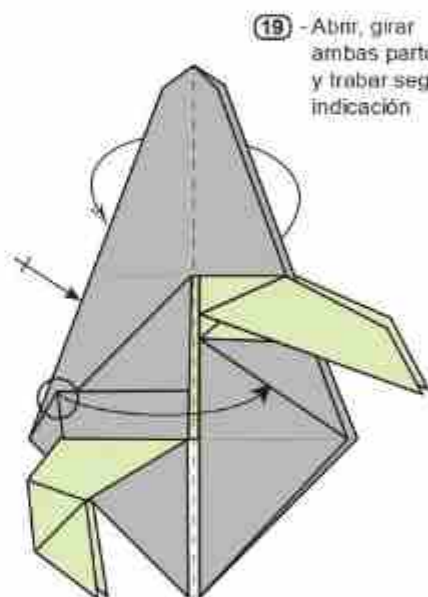

19 - Abrir, girar ambas partes y trabar según indicación

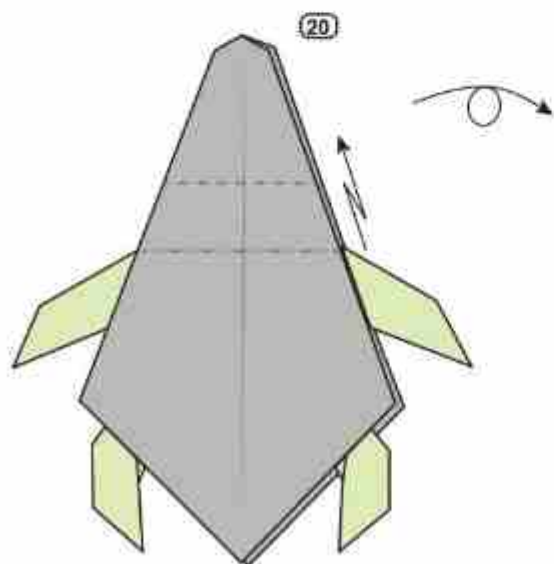

20

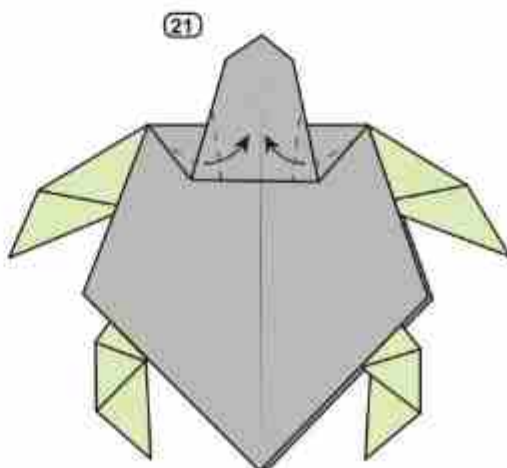

21

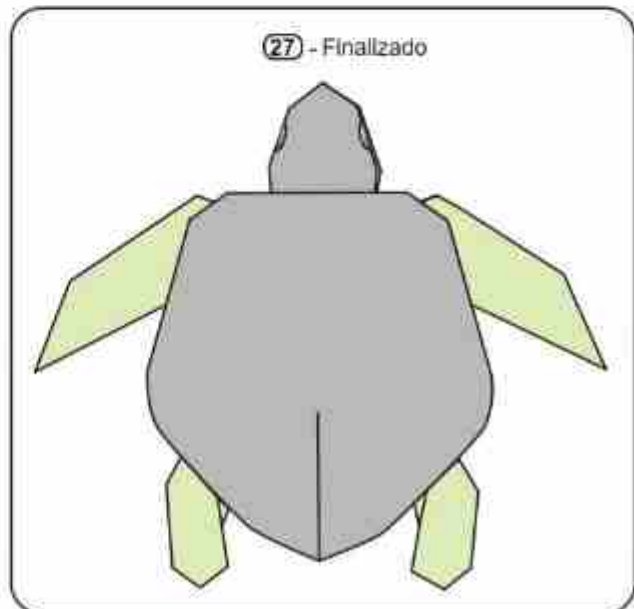
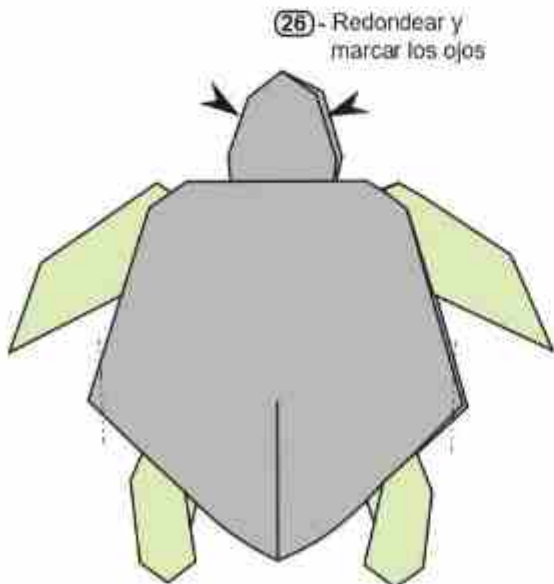
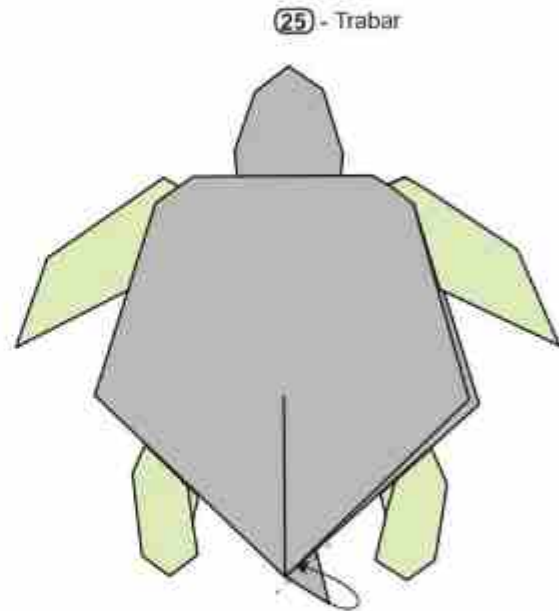
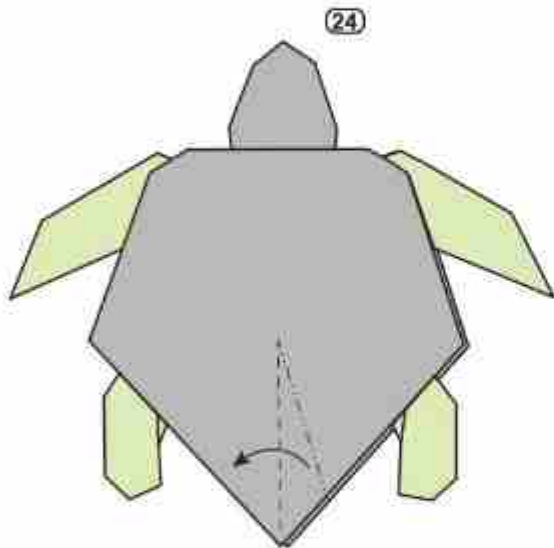
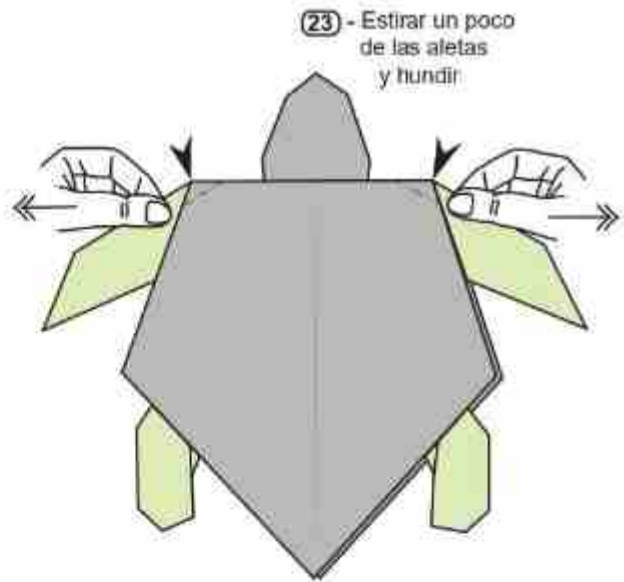
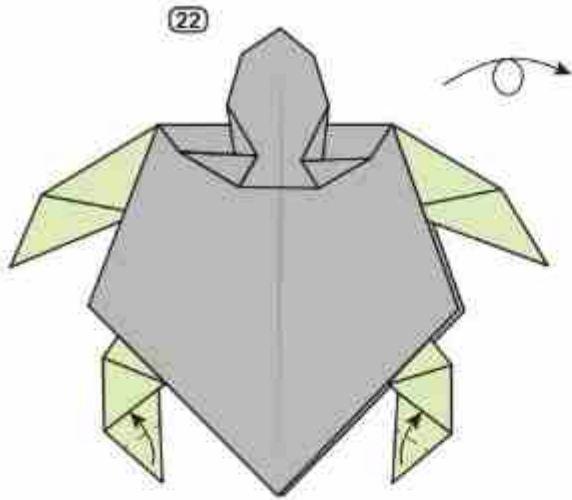

Friend of the Forest

Jesús Artigas

Ana I. Gorgas Berges (dgrms.)

©2020 - Spain

Intermediate

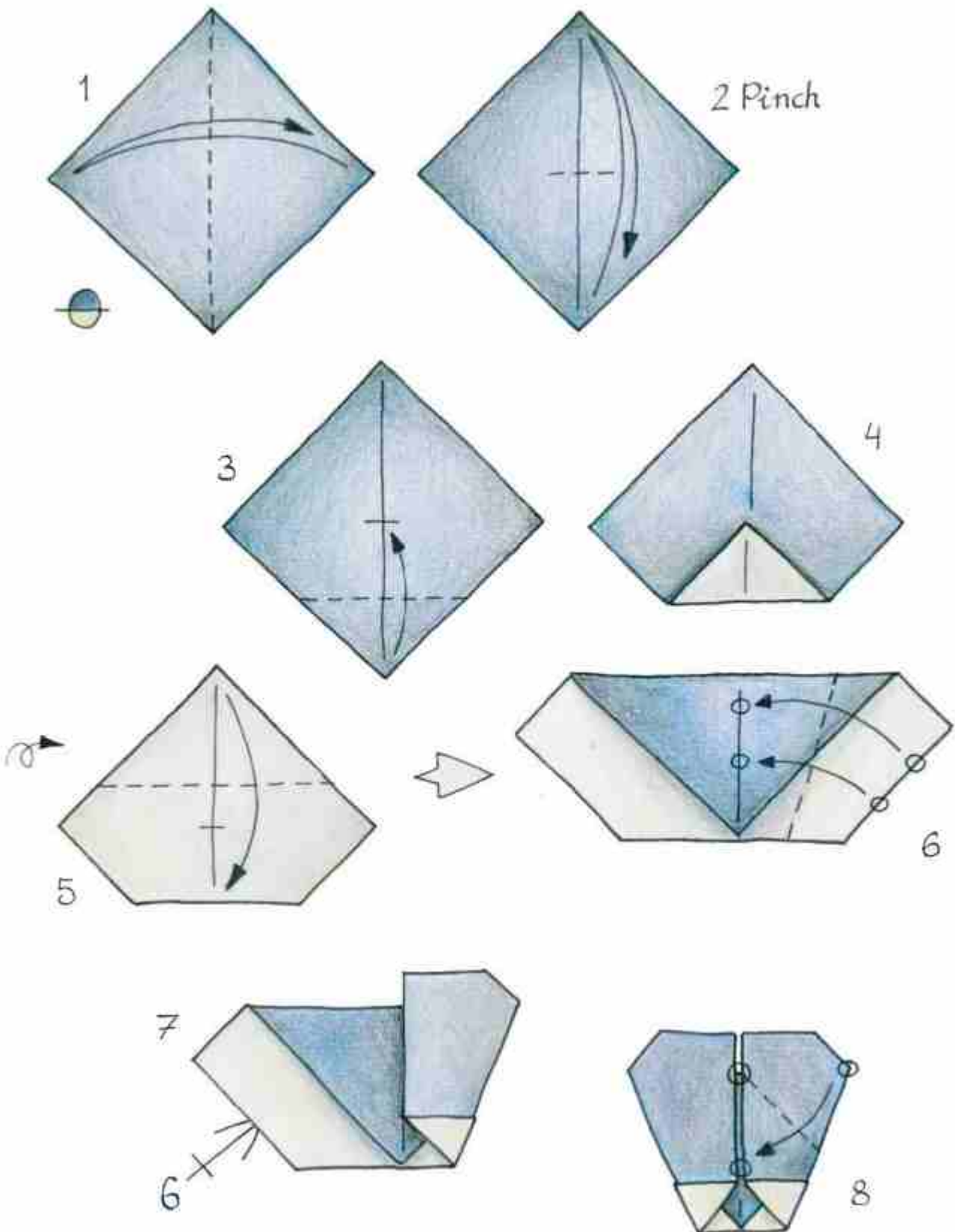

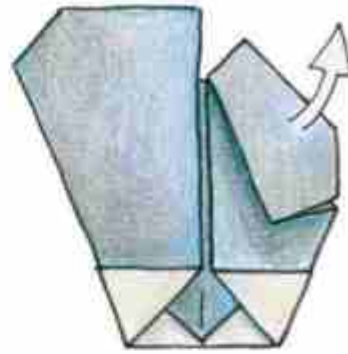
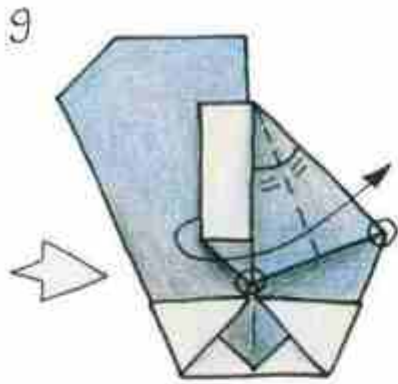

10 Unfold to step 8

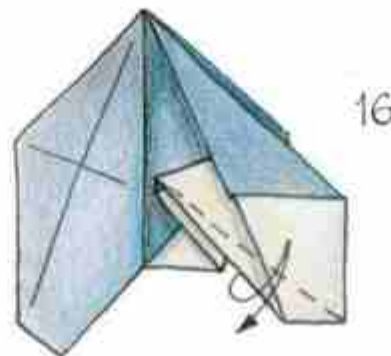
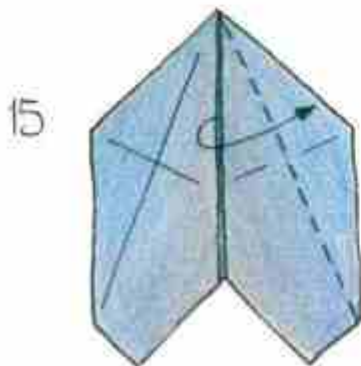
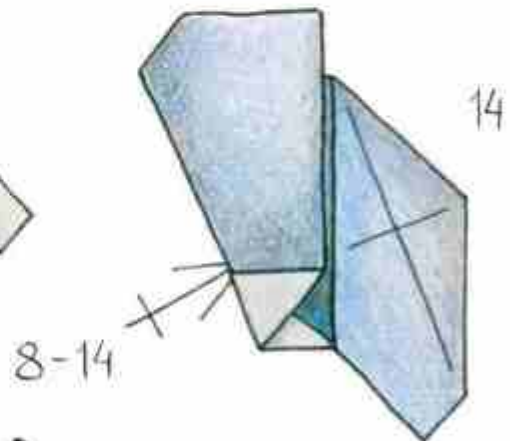
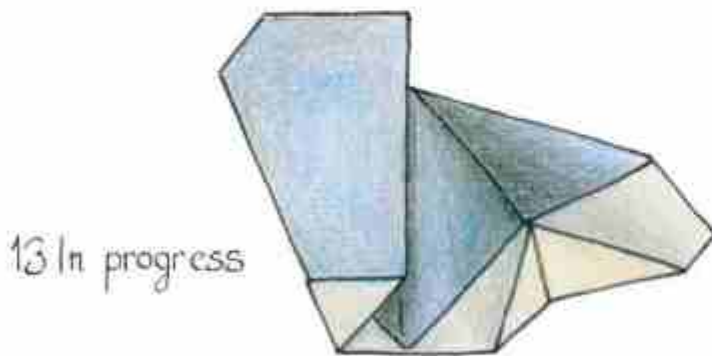
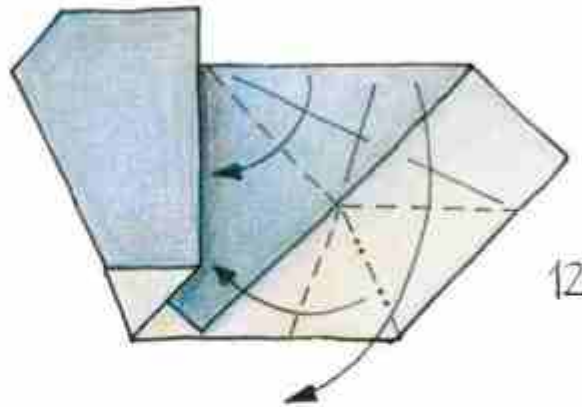
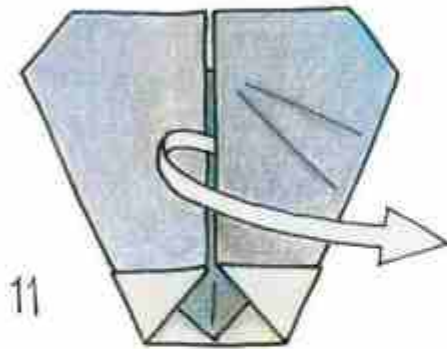

17

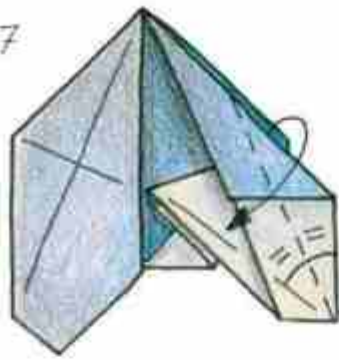

18

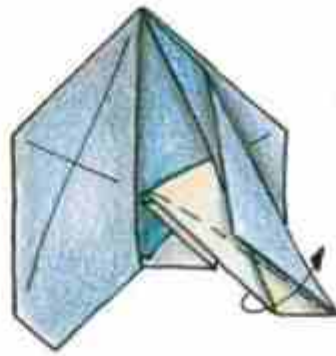

19

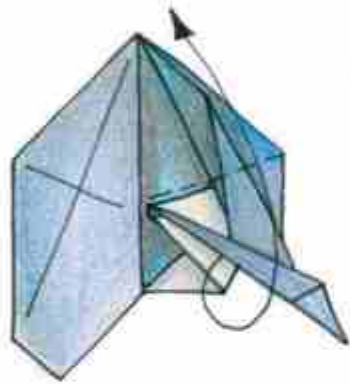

20

15-19

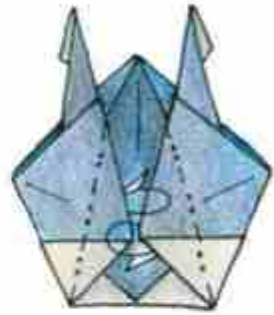
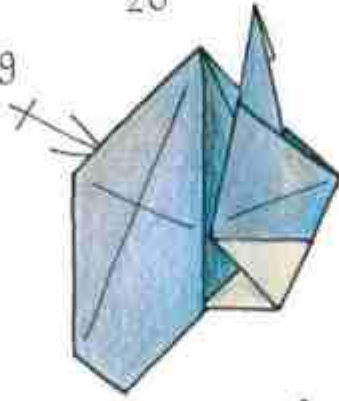

21 fold behind the pocket



22

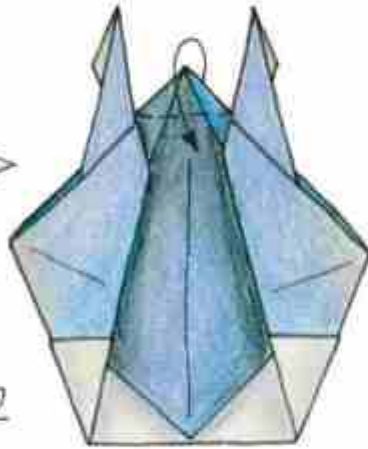

23

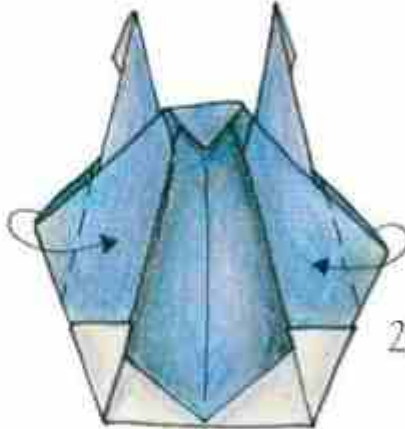

24



25 Give volume to the ears folding only the first layer

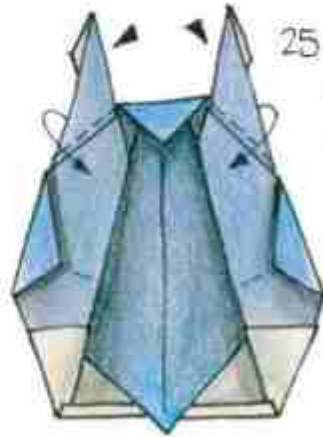

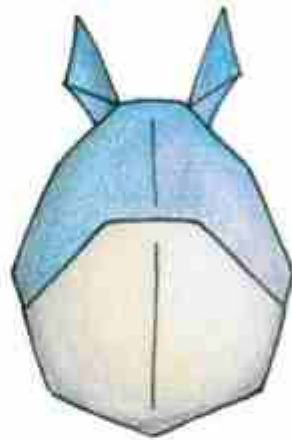
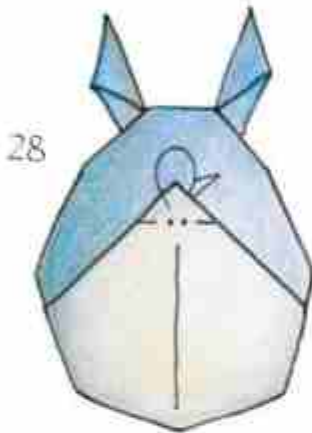
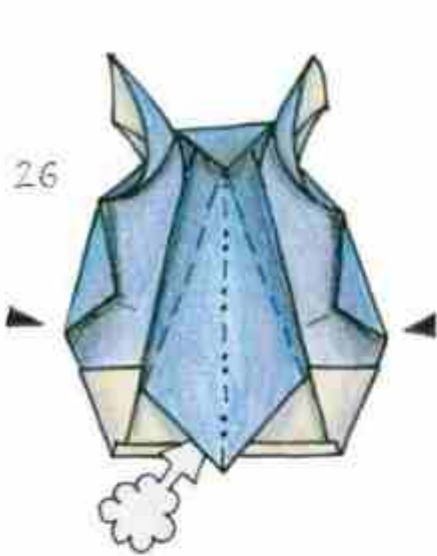

29 final



Variation

1' Start after step 2

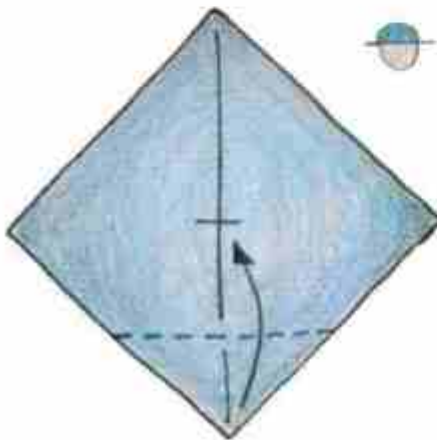

2' Repeat from step 6

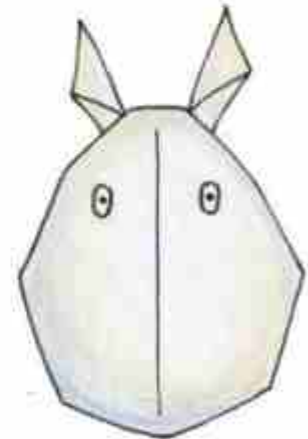
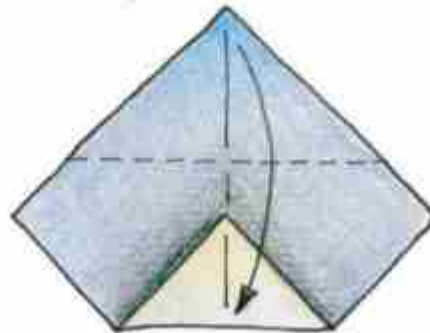

3' final

by Ana & Jesús

Sundrop Flower

Intermediate

Jesús Artigas
©2015 - Spain

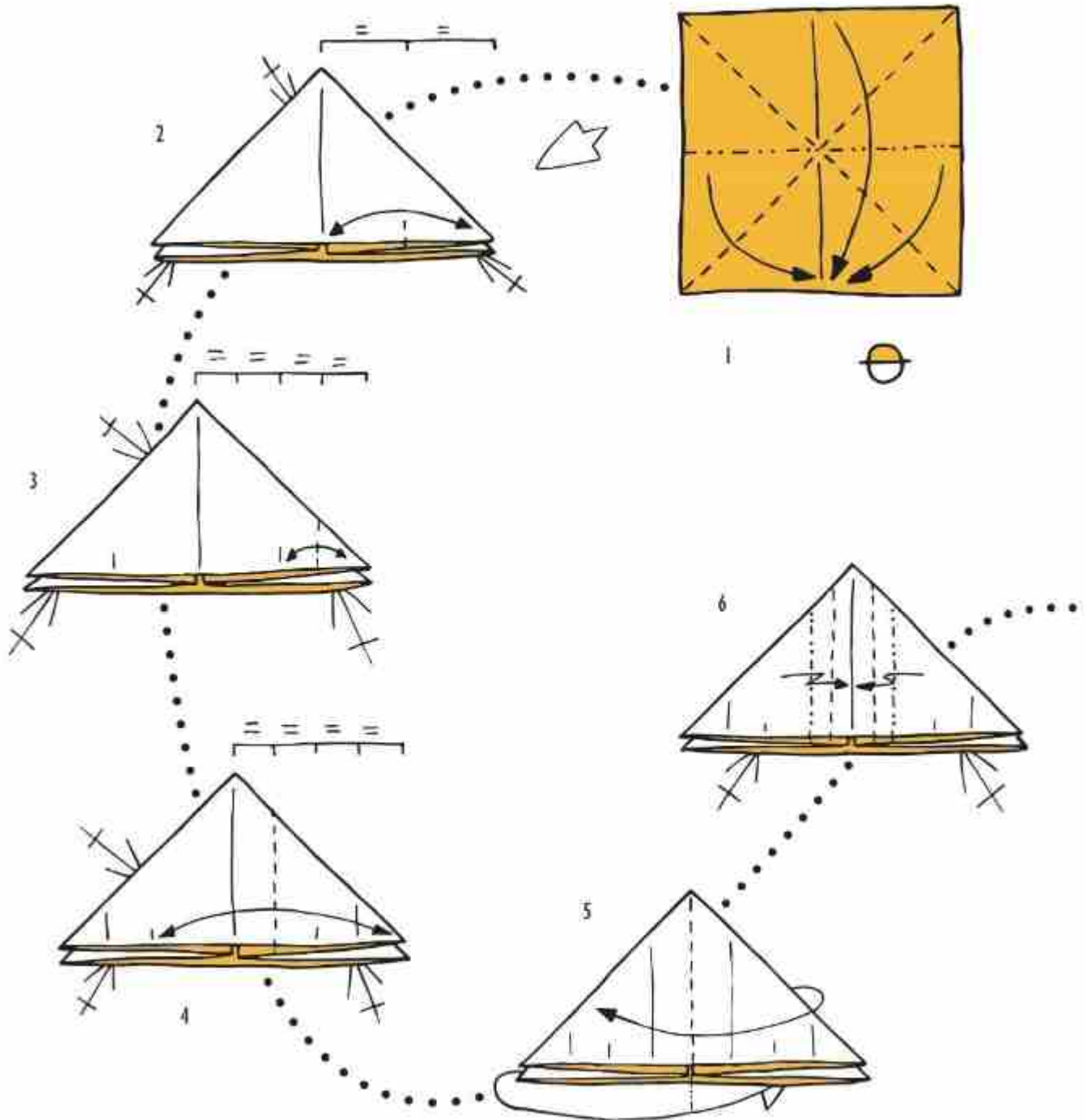

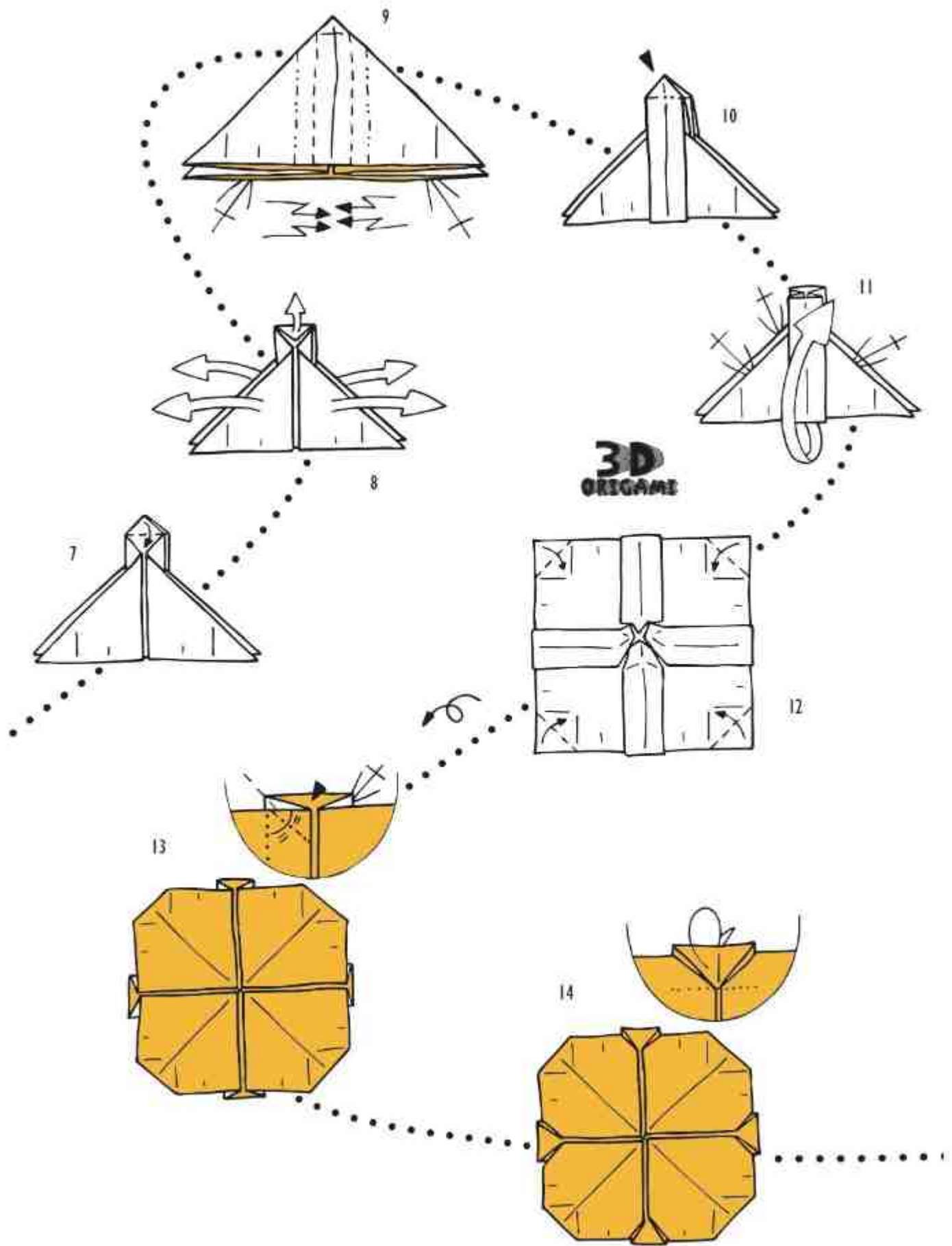

3D
ORIGAMI

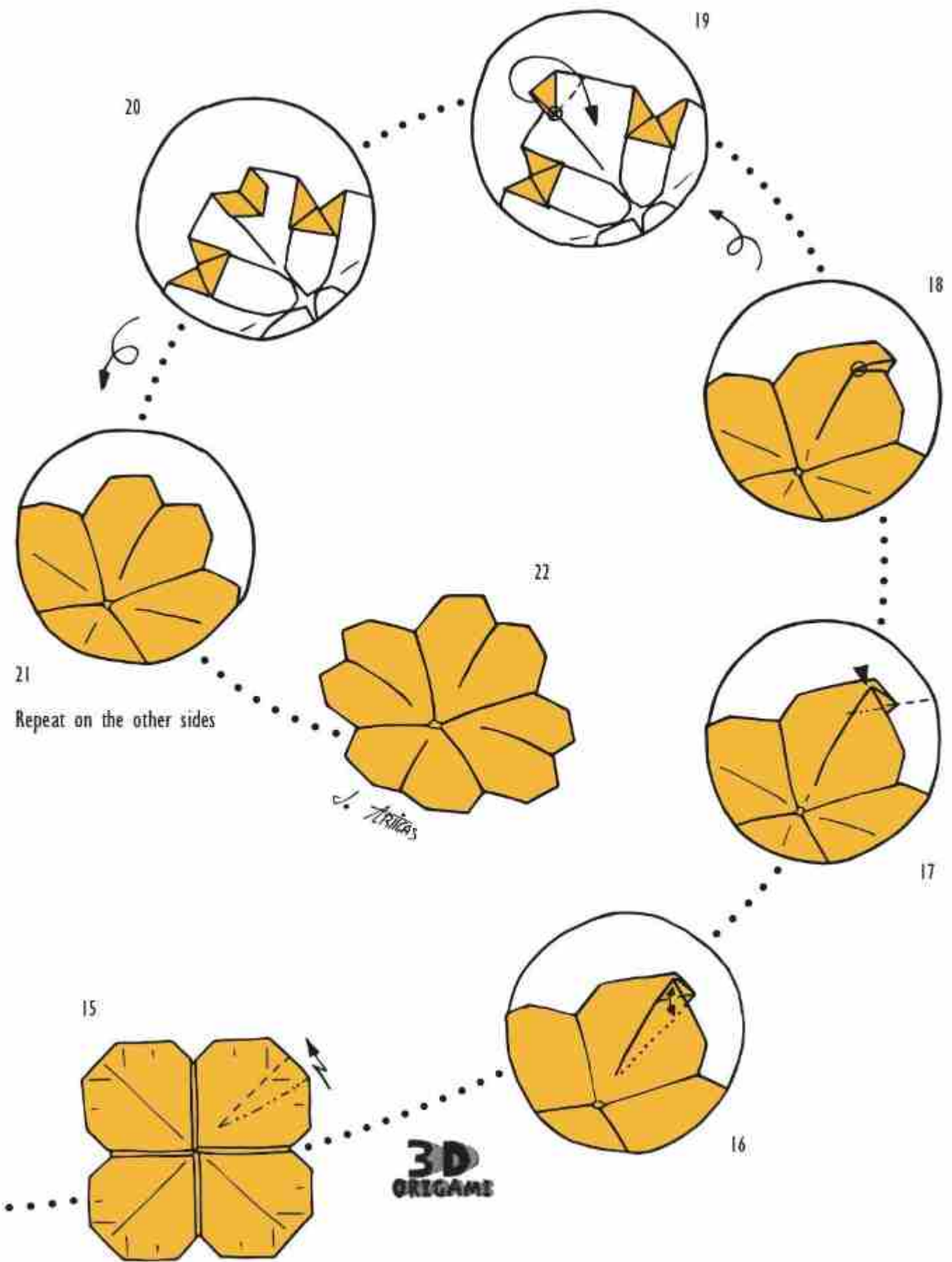

Crocodile Family in Kimono

Viviane Berty

©2019 - France

Low Intermediate



1

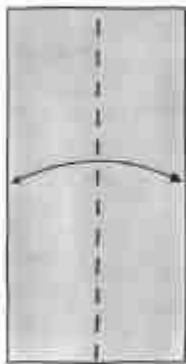

2

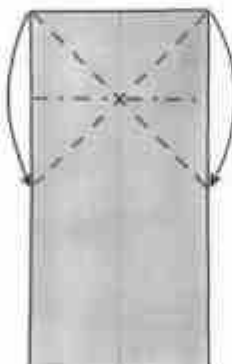

3

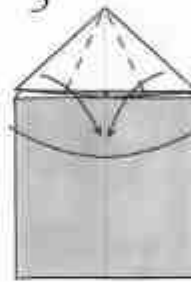

4

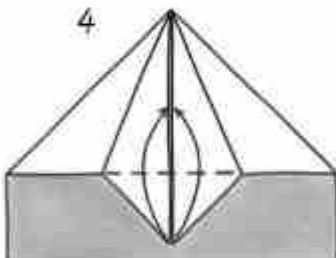

5

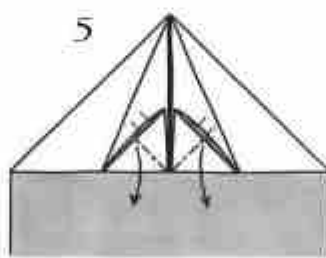

6

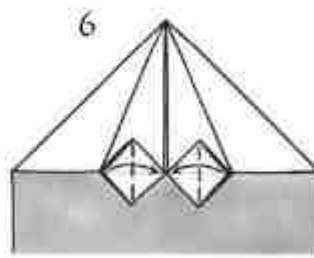

7

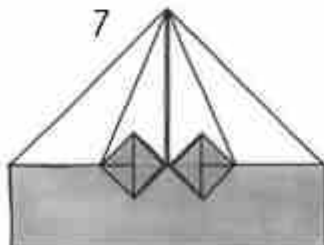

8

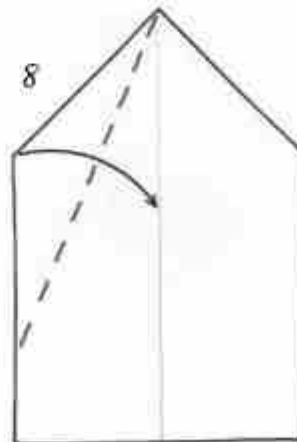

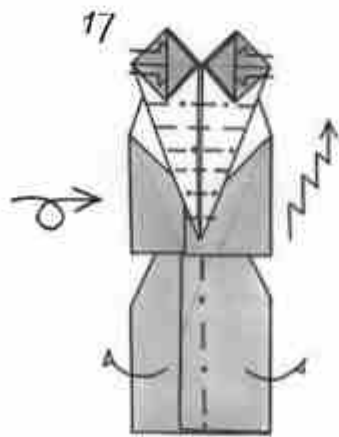
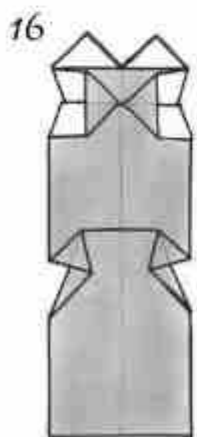
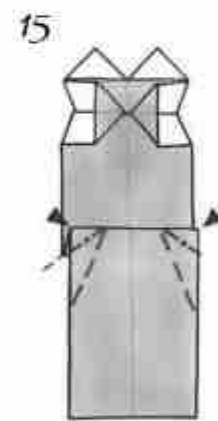
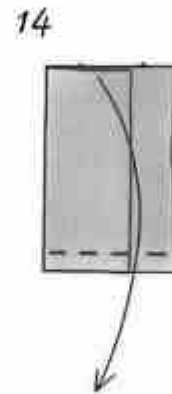
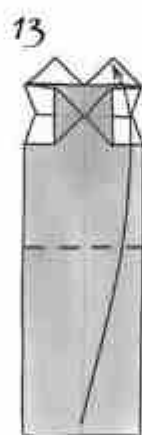
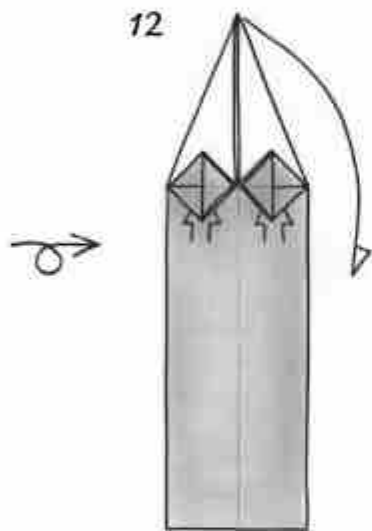
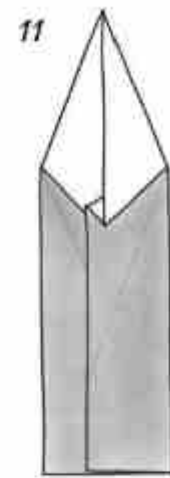
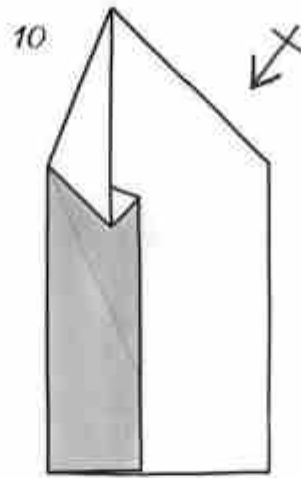
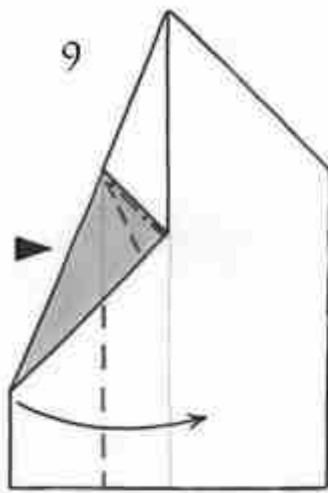

Pig Family in Kimono

Viviane Berty

©2019 - France

Intermediate



Cochon en kimono 20cm X 10 cm

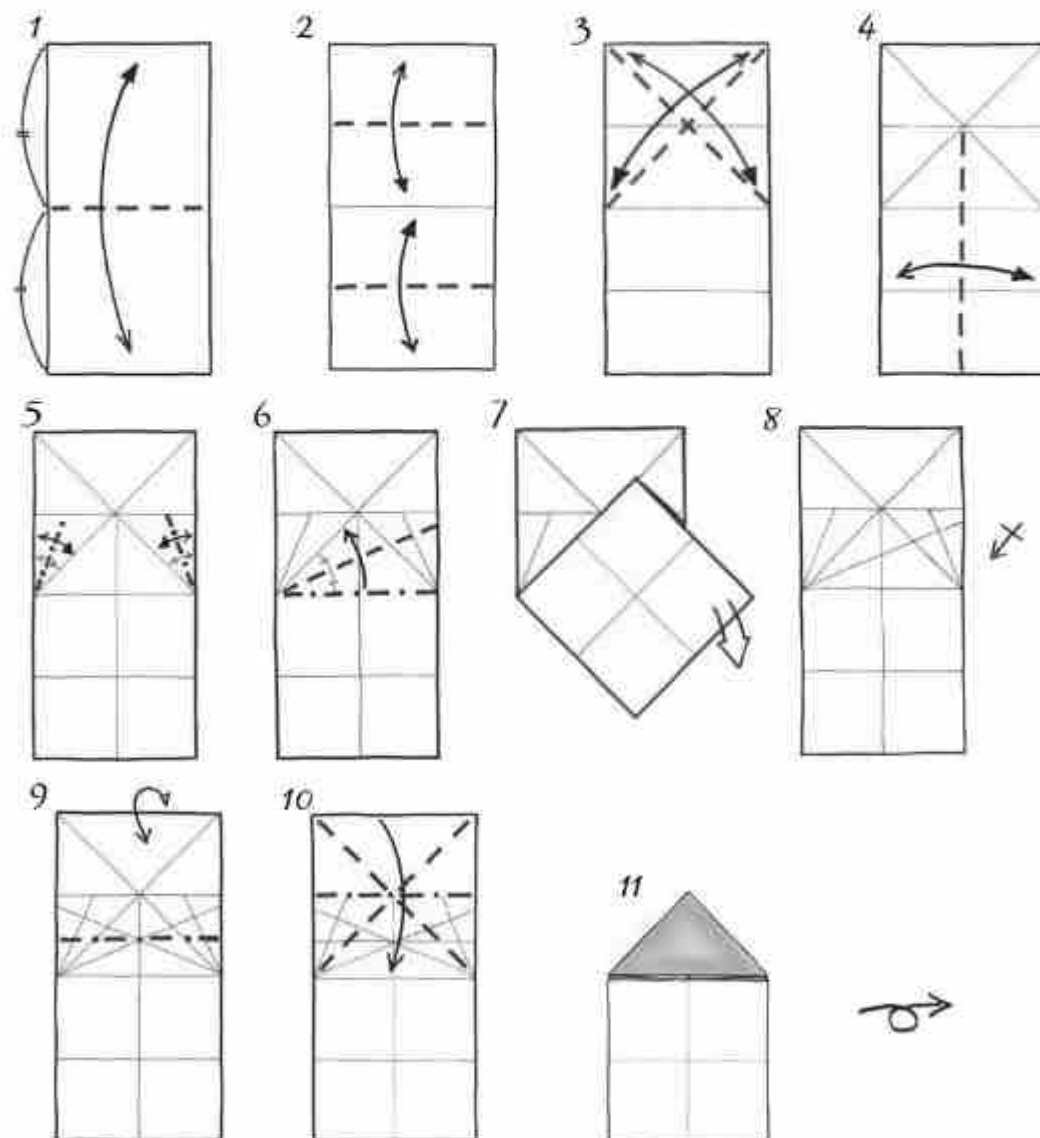

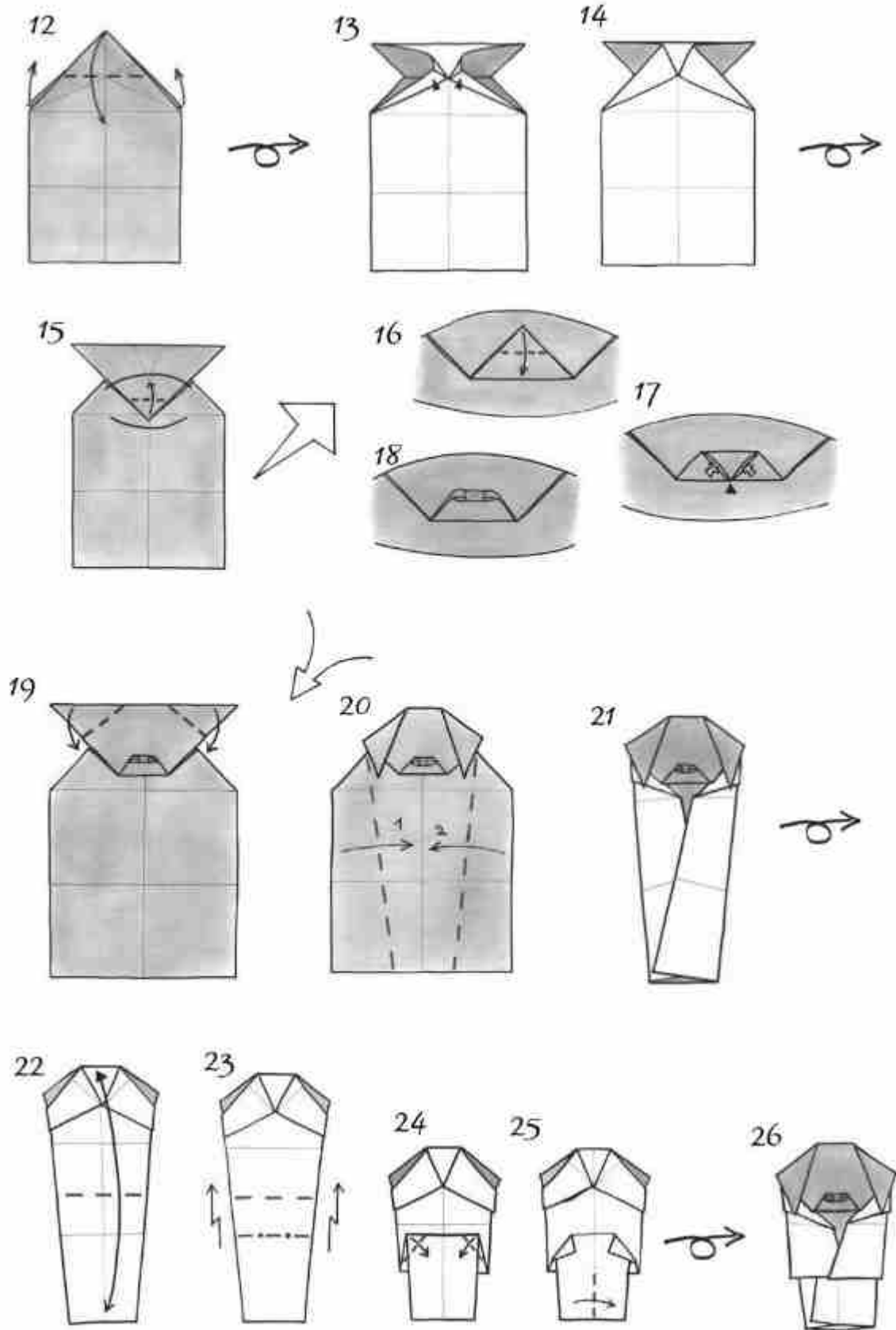



Variation : © Yannick Gardin 2019

Bébé cochon 15 cm X 7,5 cm

20 B

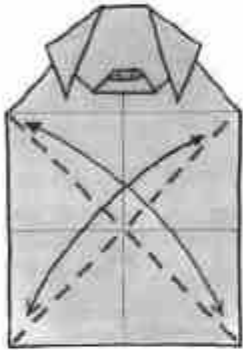

21 B

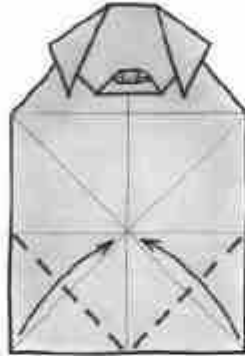

22 B

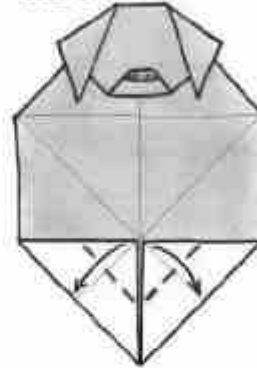

23 B

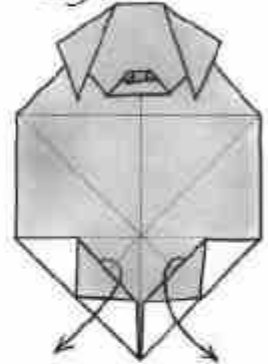

24 B



25 B



26 B

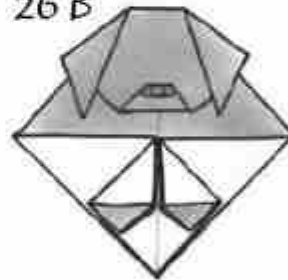

27 B



28 B

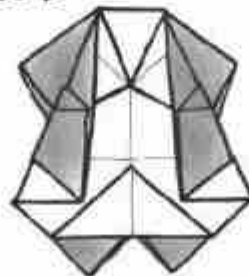

29 B

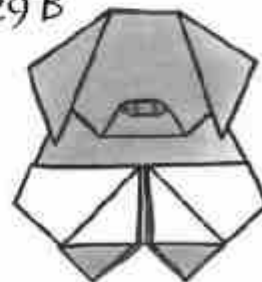

Bidirectional Tato Box

Christiane Bettens
©2023 - Switzerland

Intermediate



Choose a stiff paper

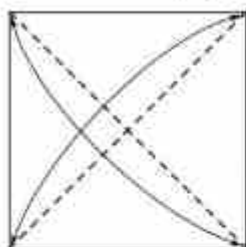

2

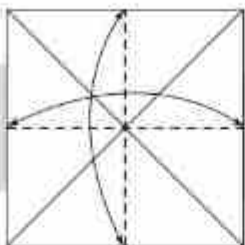

3

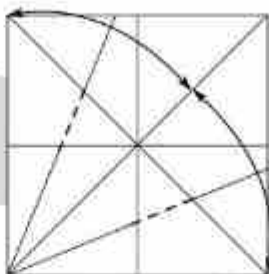

4 X

4

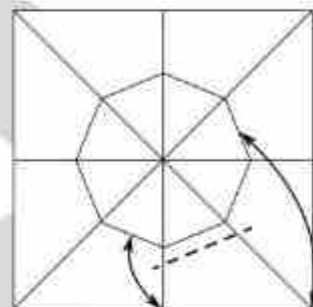

8 X

5

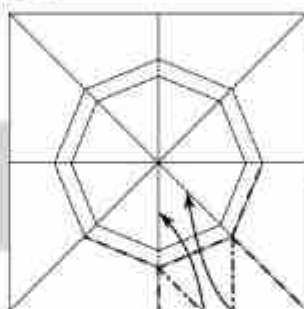

8 X rabbit-ear = tato

6



Tato

unfold

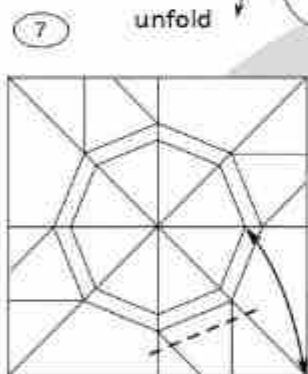

8 X

8

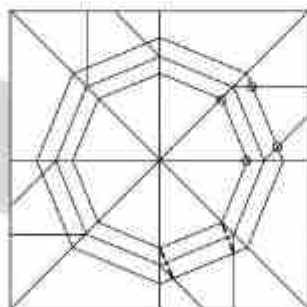

Pinch a mountain-fold 8 X

9

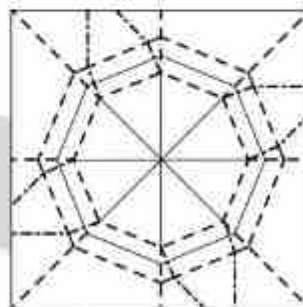

Box collapse CP

10

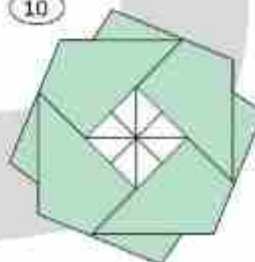

Tuck the points inside

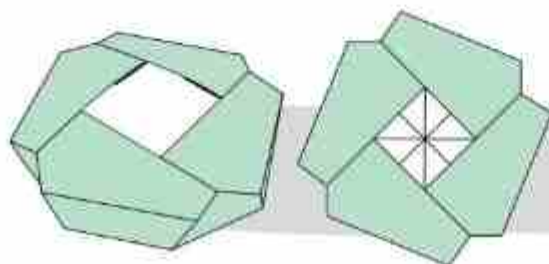

Completed box

Cat

Christophe Boudias

©2022 - Colombia

Intermédiaire

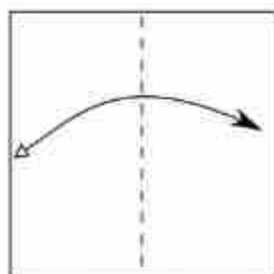

1. Plier, déplier.

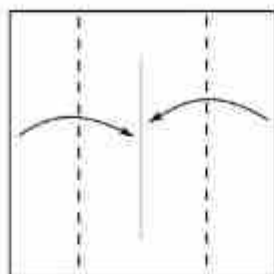

2. Plier vers le centre .

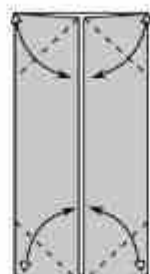

3. Marquer les plis.

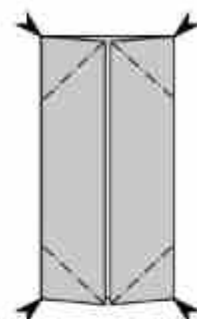

4. Pli inversé intérieur .

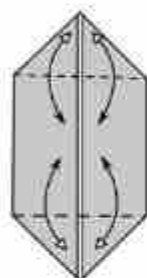

5. Marquer les plis.

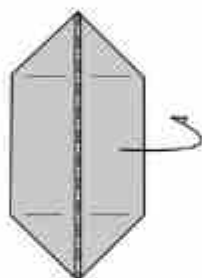

6. Plier vers l'arrière.



7. Marquer le pli sur toutes les épaisseurs.

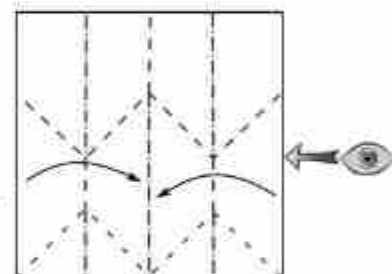

8. Déplier
COMPLETEMENT

9. Plier suivant les indications:
Montagne vallée.

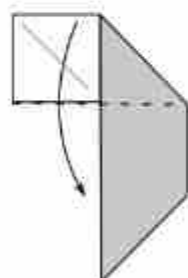

10. Plier vers le bas.

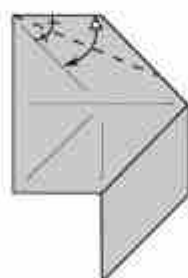

11. Marquer le pli.
C'est la bissectrice.

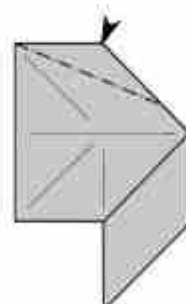

12. Enfoncement ouvert,
suivre le pli marqué
à l'étape 11.

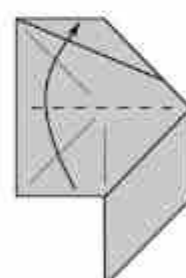

13. Plier vers le haut.

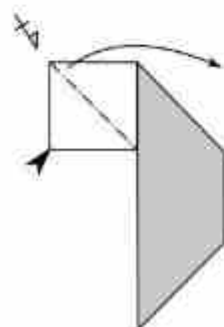

14. Étirer vers la droite.

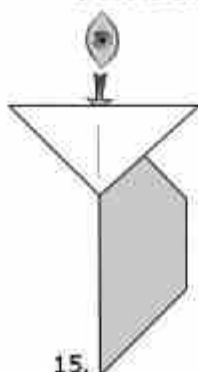

15. Changement de vue.

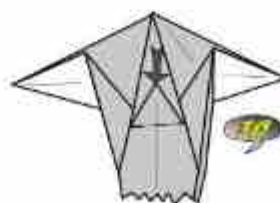

16. Étirer l'enfoncement
réalisé à l'étape 12
vers le bas.

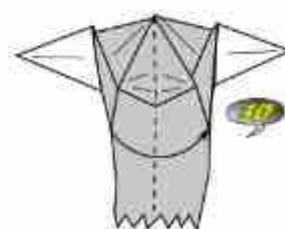

17. Refermer le modèle.

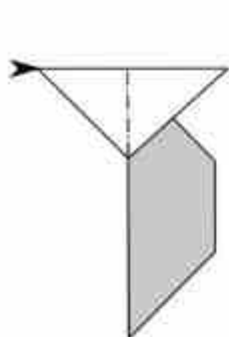

18. Pli Inversé Interieur .

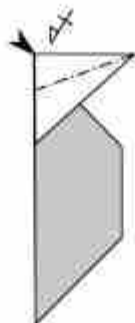

19. Pli Inversé Interieur, répéter derrière .



20. Pli Inversé Interieur .

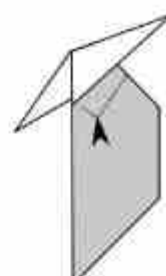

21. Pli Inversé Interieur sur l'étirement formé en 16 .

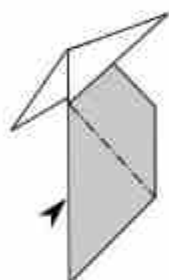

22. Pli Inversé Interieur .

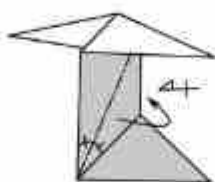

23. Pli montagne suivre la bissectrice. Répéter derrière.

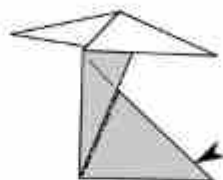

24. Pli Inversé Interieur .



25. Ouvrir au milieu.

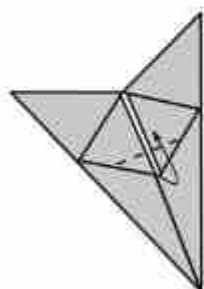

26. Plier vers le haut.

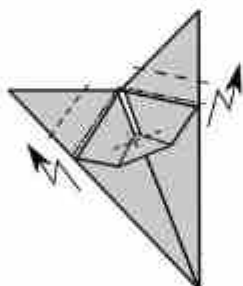

27. Plier vers le bas le bout du nez. Zig-zag pour les oreilles.

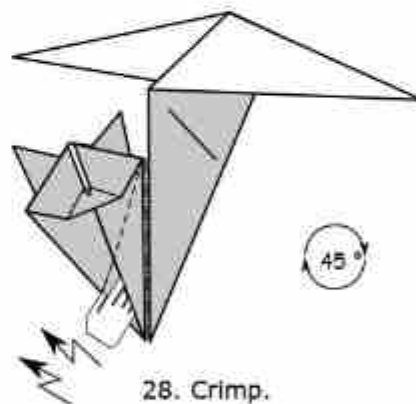

28. Crimp.

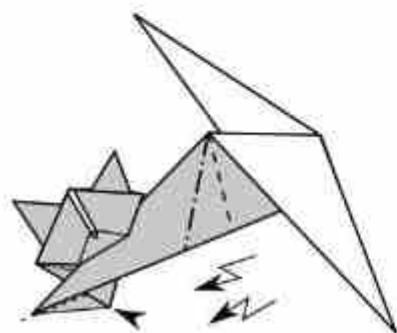

29. Pli pivot pour la patte. Crimp pour le corps.

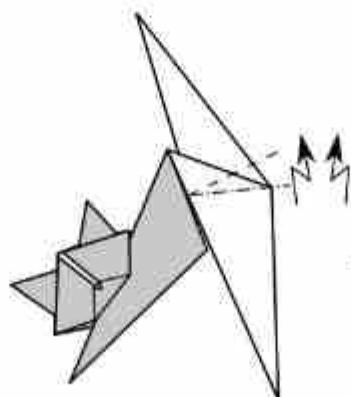

30. Crimp pour la queue.

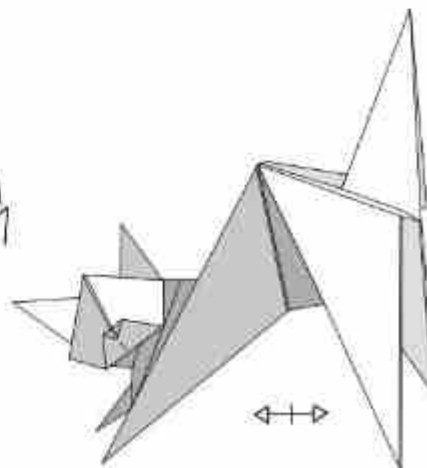

Orchid

Christophe Boudias

©2022 - Colombia

Intermediate

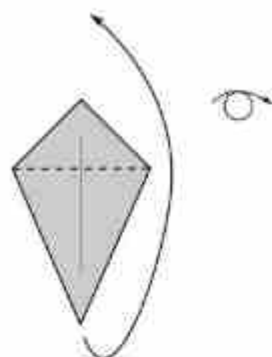

1. Base de loiseau, plier une aile vers le haut.

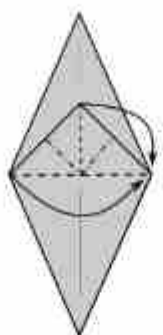

2 Refermer le modèle.

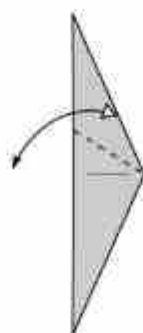

3. Marquer sur toutes les épaisseurs.



4. Pli inversé extérieur.

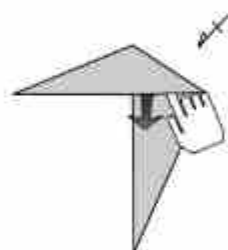

5. Sortir du papier pour changer de couleur. Le replacer vers le haut

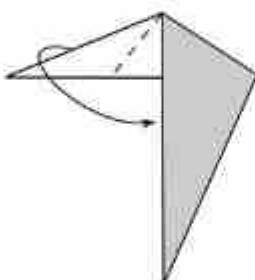

6. Marquer sur toutes les épaisseurs.

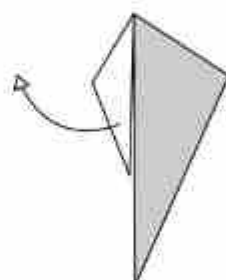

7. Déplier.

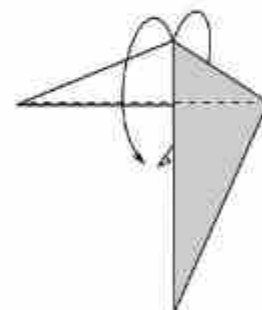

8. Plier vers le bas.

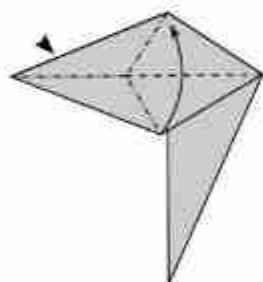

9. Pli inversé intérieur sur la pointe de gauche et, replacer l'aile vers le haut.

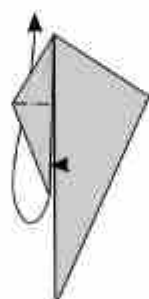

10. Pli inversé intérieur vers le haut.

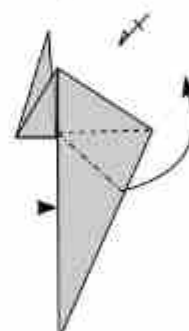

11. Pli aplati. Répéter derrière.

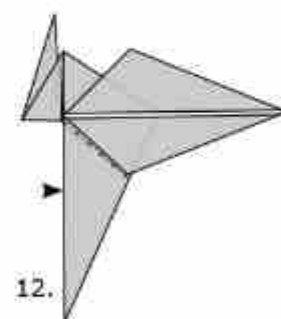

12. Pli inversé intérieur.

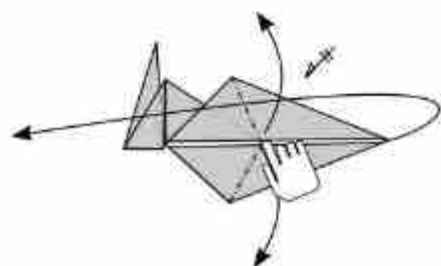

13. Ouvrir chaque aile et plier vers la gauche

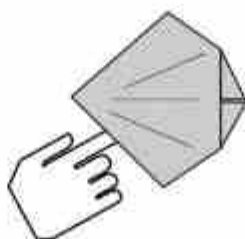

14. Ouvrir le modèle. Positionner la pointe centrale.

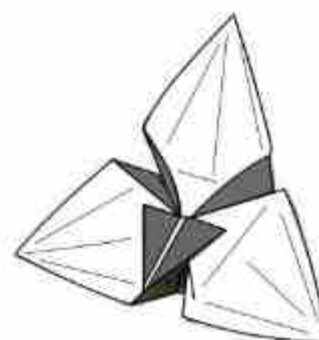

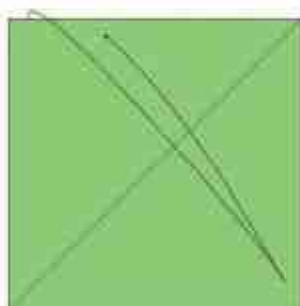
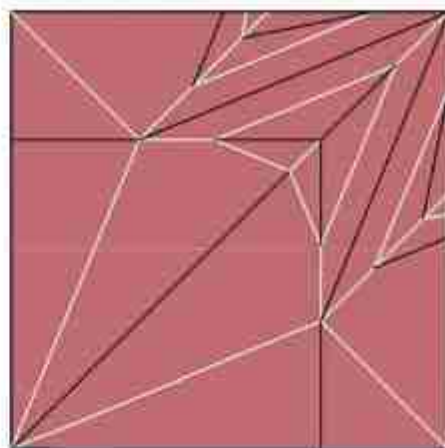
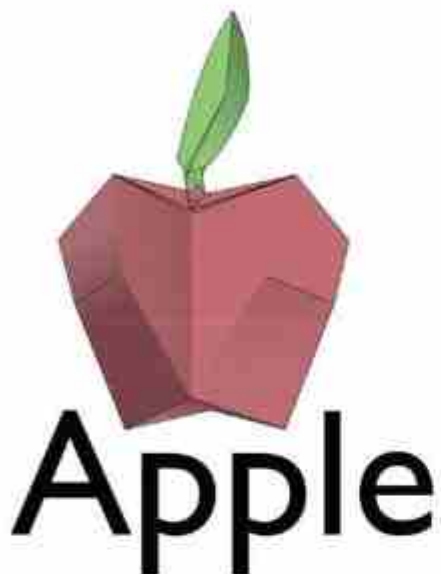

1. Fold and unfold along the diagonal.



2. Rabbit-ear two corners, forming the Fish Base.



3. Mountain-fold one half behind.



4. Crease the long flap along the edge of the short flap in front of it.

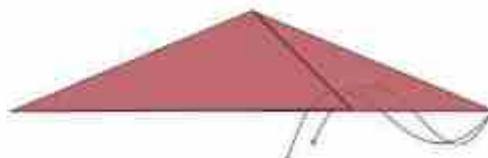

5. Double inside reverse-fold along existing creases.

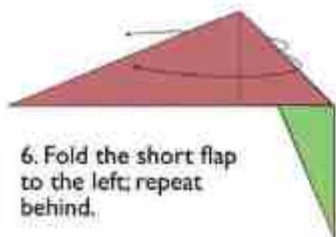

6. Fold the short flap to the left; repeat behind.

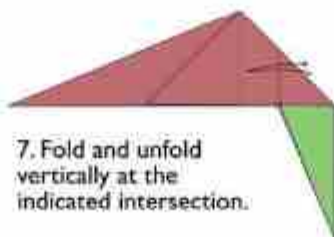

7. Fold and unfold vertically at the indicated intersection.

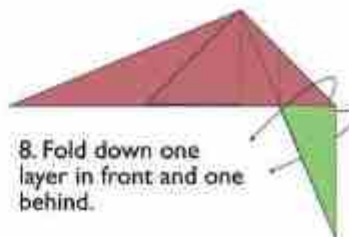

8. Fold down one layer in front and one behind.

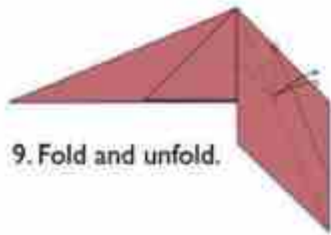

9. Fold and unfold.

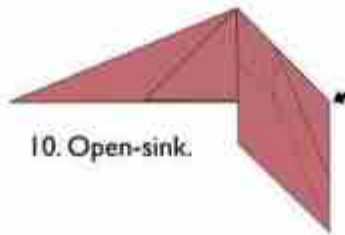

10. Open-sink.

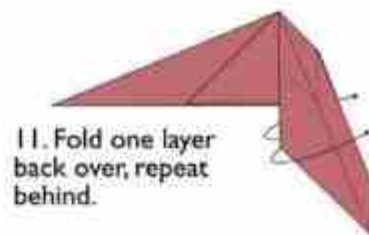

11. Fold one layer back over, repeat behind.

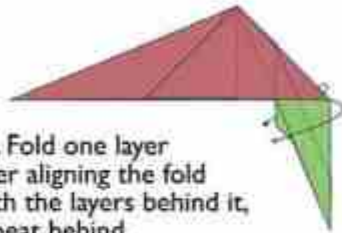

12. Fold one layer over aligning the fold with the layers behind it, repeat behind.

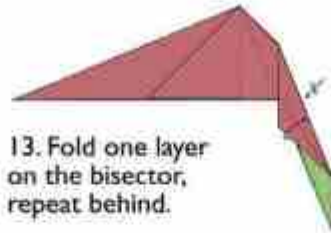

13. Fold one layer on the bisector, repeat behind.

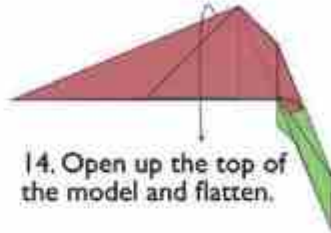

14. Open up the top of the model and flatten.

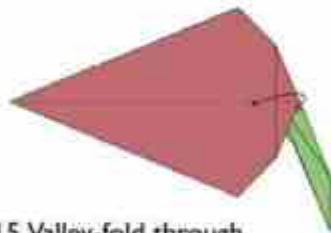

15. Valley-fold through all the layers.

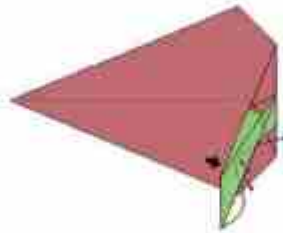

16. Inside reverse-fold the flap while making a shallow closed sink. The layers will not be symmetric.

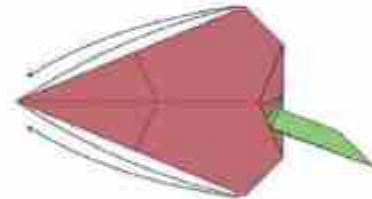

17. Precrease from corner to corner with mountain folds.

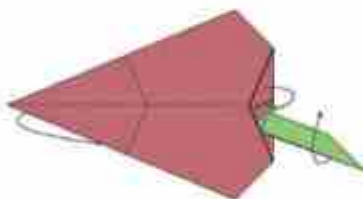

18. Collapse on the existing creases and along the layers near the stem, while folding the stem outwards. Keep these new folds partial; the model should not lie flat.

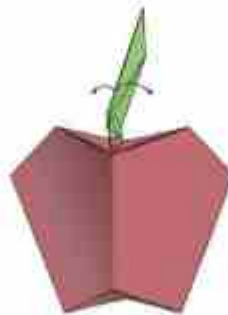

19. Fold open the leaf edges to either side.

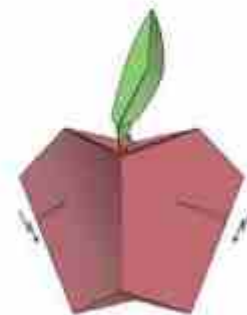

20. (Optional) Make two shallow pleat folds to give the model some bulge.

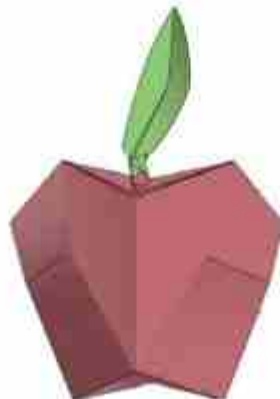

Finished apple.

Flags with Stripes

Sy Chen

©2023 - USA

Simple

Designed on 2/16/2023 and diagrammed in 2/18/2023.

After coming up a double-sided Costa Rica flag design, I found the sliding method used can be applied to many other striped flag designs.

2 duo-color 16 cm squares make a 6 cm x 8 cm flag.

Method I - 1 two-adjacent stripe piece + 1 single stripe piece

Upper Stripe Piece

1. Start from a square having the same color as the upper stripe of the flag. Put the colored side facing down.

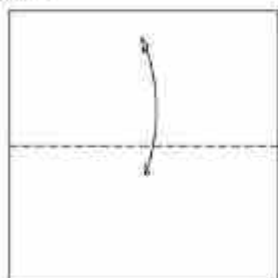

2.

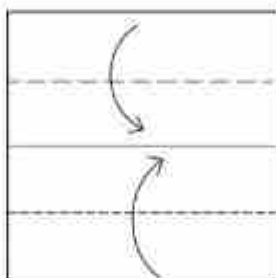

3.



4.



5. The first piece completed.



Lower 2-Stripe Piece

1. Start from a duo-color square with the colors matching the colors of 2 lower stripes separately.

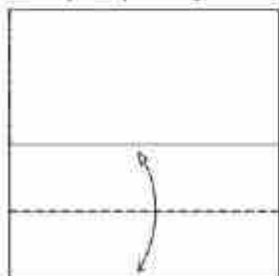

2.

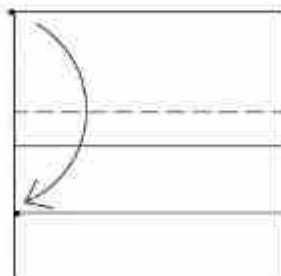

3. Pleat.



4.



5. Two-2nd piece completed



Assembly

1. Slide both pieces together as indicated.

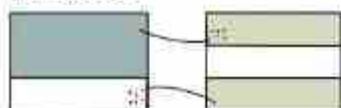

2. Make sure the left piece show 2 lower colors and the right piece show 1 upper color on both sides.

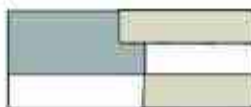

3. Completed.

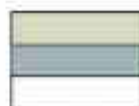

Method II - 1 two-separated stripe piece + 1 single stripe piece

Two-Separated-Stripe Piece

1. Start from a square with one side color as the upper stripe and the other side color as the lower stripe.

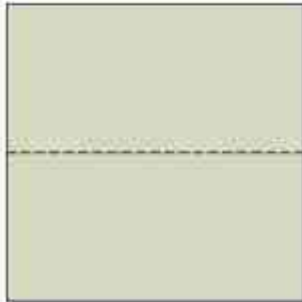

2.

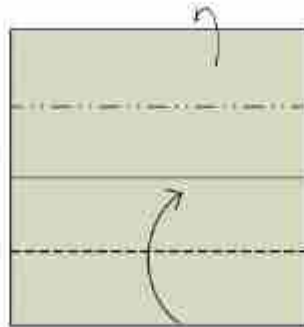

3.

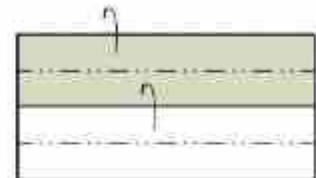

4.



5. The first piece completed.



Center Stripe Piece

1. Start from a square with the color matching the center stripe color

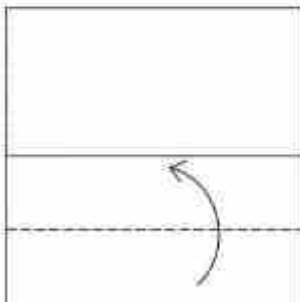

2.

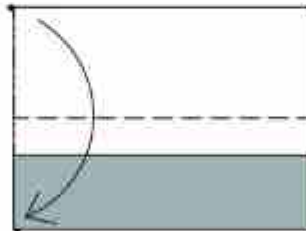

3.



4.



Assembly

1. Slide both pieces together as indicated on both sides.



2.

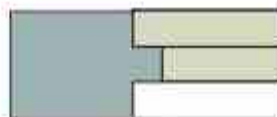

3. Completed.

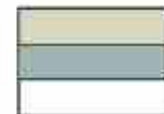

Alternative from 2 pieces of 2x1 rectangles

Upper Stripe Piece

1. Put the 2x1 rectangle with the stripe color side facing down.



2.

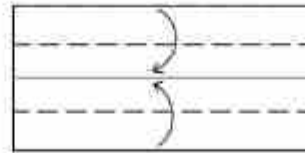

3.



4.



Lower 2-Stripe Piece

1.

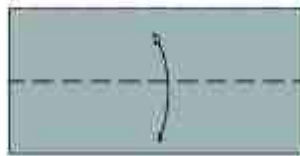

2.

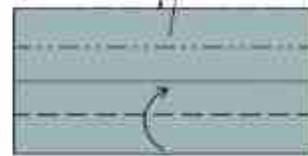

3.

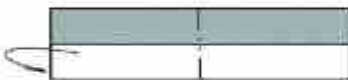

4.



Assembly

1. Slide both pieces together as indicated on both sides.

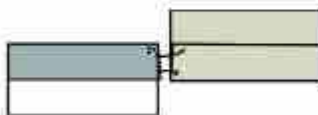

2. In-progress.

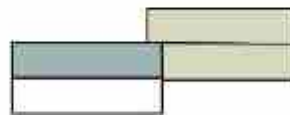

3.

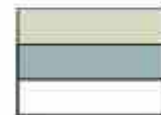

Flags with three colored horizontal stripes

 Bulgaria

 Lithuania

 Estonia

 Luxembourg

 Gabon

 Netherlands

 Germany

 Russian Federation

 Hungary

 Sierra Leone

Three-Unit Direction Dice

Sy Chen

©2019 - USA

Low Intermediate

Designed on 5/21/2019 and diagrammed from 5/21/2019 to 5/24/2019

Based on Jim Weir's original 3 Unit Seamless Cube. The single arrowed facet landing idea is coming from Sy Chen's Direction Dice. The finished dice is pretty secure, even though the unit folding is surprisingly simple

1. Prepare 3 squares. Start from one of them.

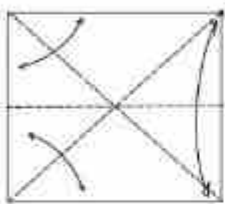

2. This step trisects diagonal

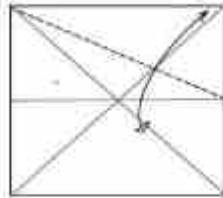

3.

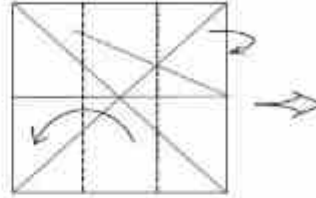

4.



5. Make another unit.

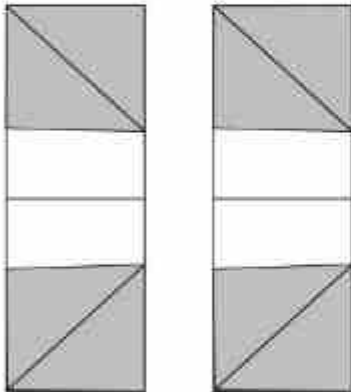

6. Repeat steps 1-4 for making the 3rd unit from a new squared paper.



7.



8.

turn over

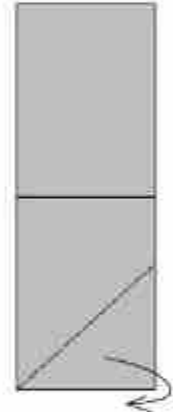

9.



turn over

10. The 3rd unit.



11. 3 Units together. Bend each valley line to form 3D.

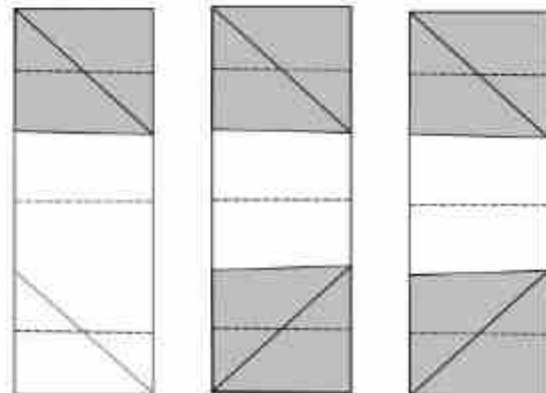

12. The 3 bent units in 3D view.

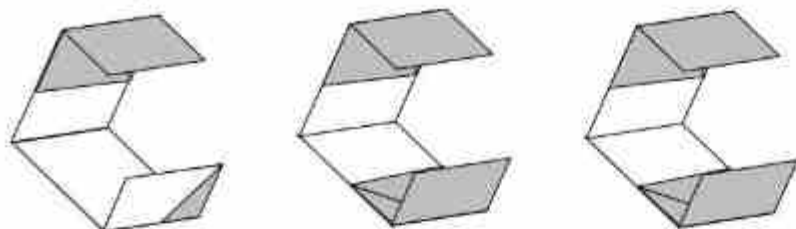

13. Rotate and assemble units to make a cube by tucking tabs into pockets of the other units. Only two pockets of each unit are used.

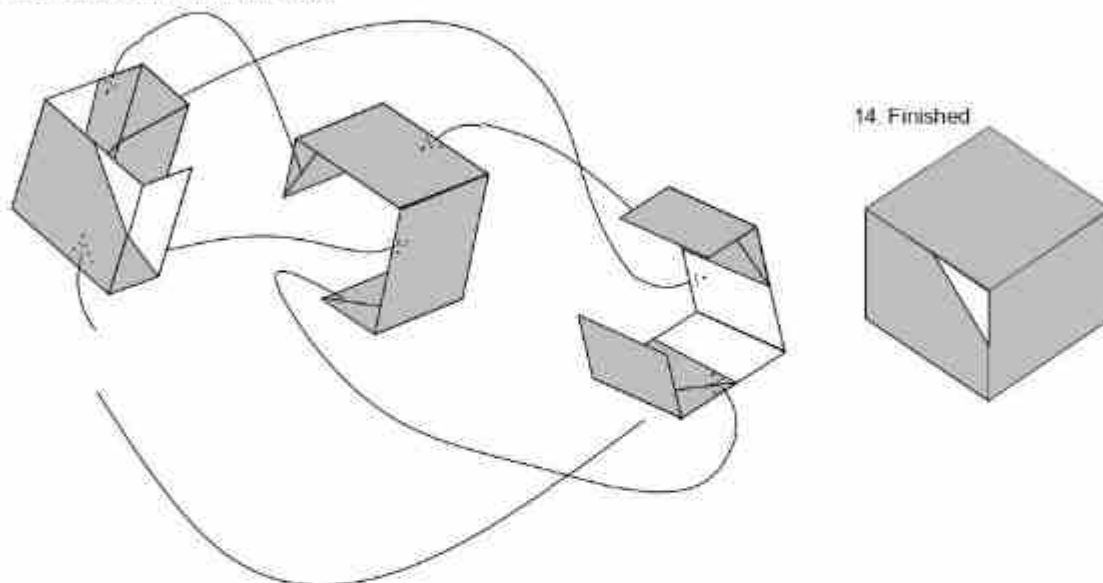

Dice Point Counting

Players can use the arrow landing location to determine the dice value. One of my favorite point mappings is 1 \blacktriangledown (NE), 2 \blacktriangle (SE), 3 \blacktriangleright (SW), 4 \blacktriangleleft (NW), 5 $_$ (bottom), and 6 $_$ (top).

Triangle landing on the side facet - identified by the corner position on the landing facet

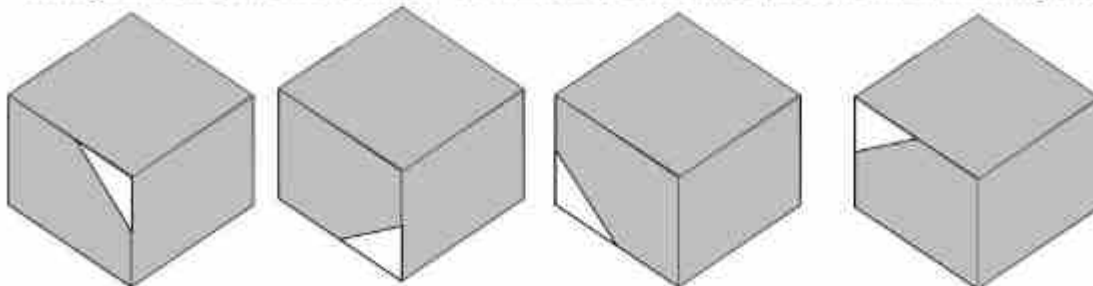

Landing on the top

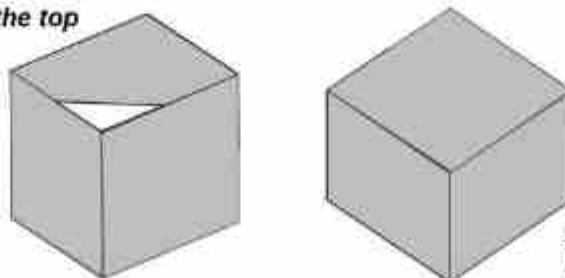

Landing on the bottom - hidden

Tightrope Walker

Paul Cléménçon
©2023 - France

High Intermediate



Sandwich (or kami)
40 x 20 cm is
recommended

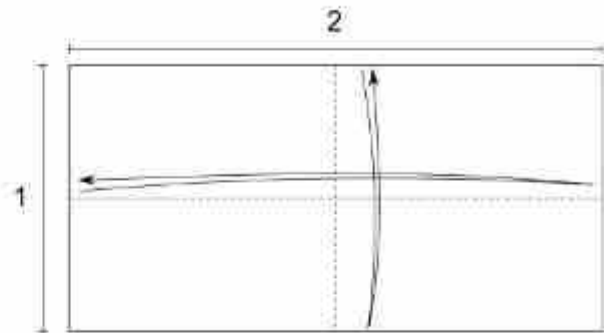

1 - We will build a 7x4 rectangle from a 2x1 rectangle. Fold and unfold.

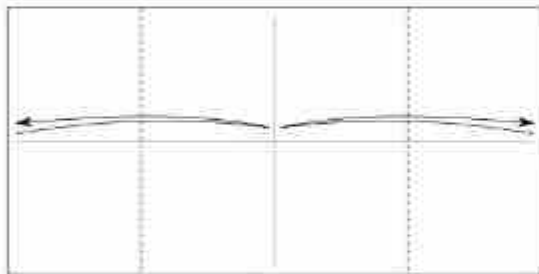

2 - Fold and unfold

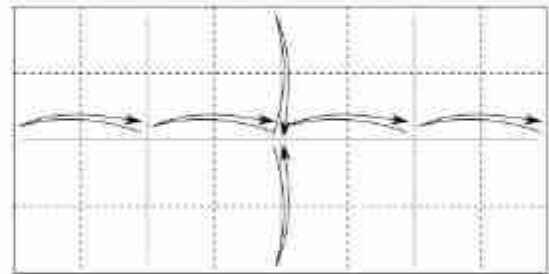

3 - Fold and unfold

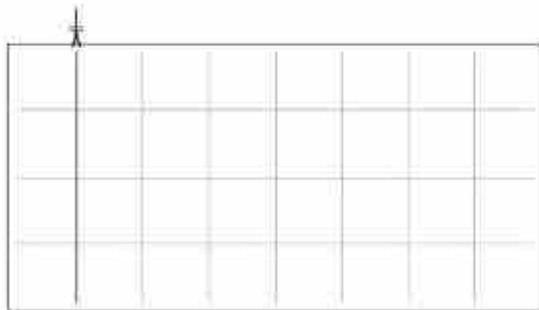

4 - Remove the extra stripe of paper

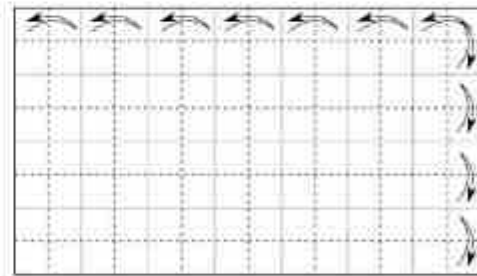

5 - Fold and unfold. Turn over.

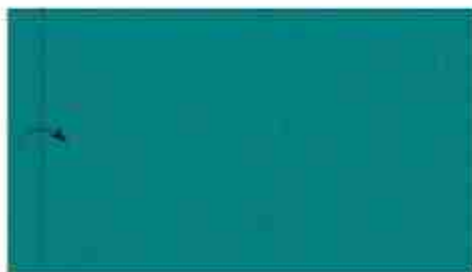

6 - Fold the left edge



7 - Align the raw edges



8 - Fold up



9 - Mountain fold



10 - Fold the two corners to the right



11 - Fold the model in half



12 - Squash fold



13 - Petal fold

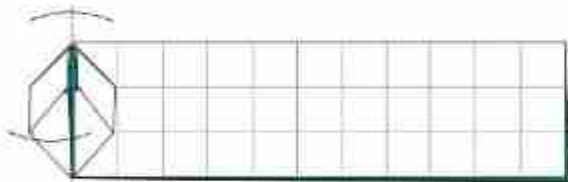

14 - Fold one flap in front and back.
Turn over.

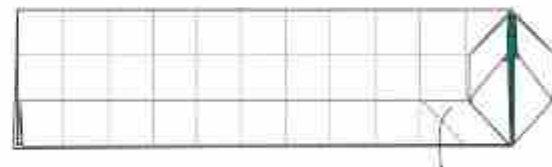

15 - Pull out some paper.



16 - Mountain fold. See reference.

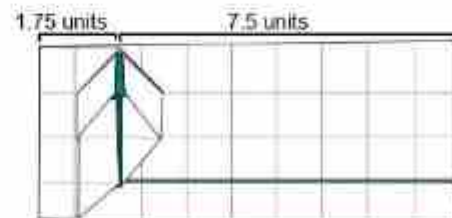

17 - Result

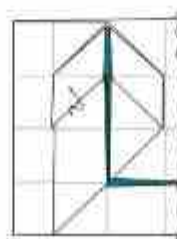

18 - Put the hidden flap in front of the model

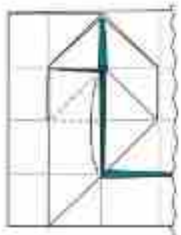

19 - Squash fold

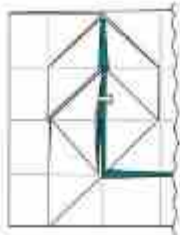

20 - Pull out some paper

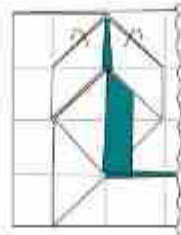

21 - Wrap the corners

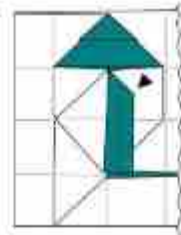

22 - Inside reverse fold



23 - Mountain fold.

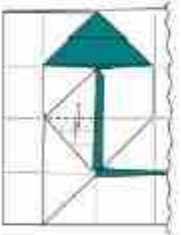

24 - Pleat



25 - Fold the corner. It will be the hand

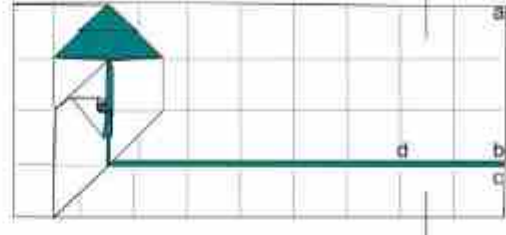

26 - Open the layers, crease the following lines and close the layers



26a - Pleat



26b - Fold and Unfold

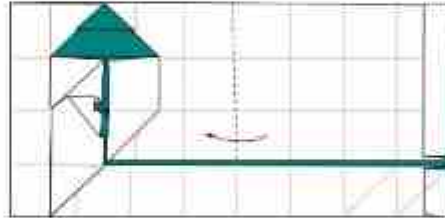

27 - Fold using the existing line

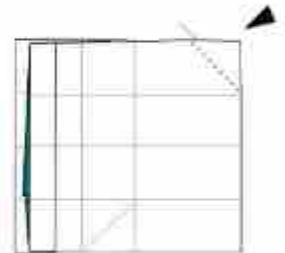

28 - Squash fold

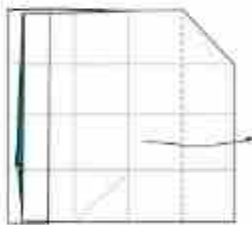

29 - Fold the layer

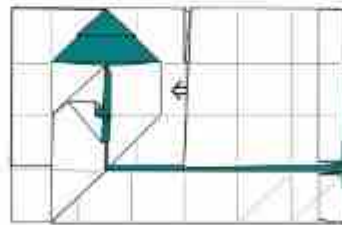

30 - Pull out some paper

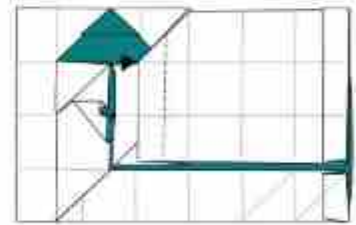

31 - Open sink

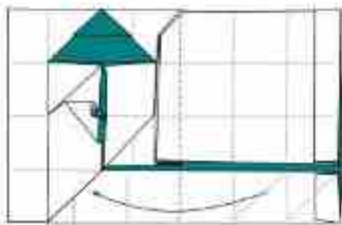

32- Fold the flap

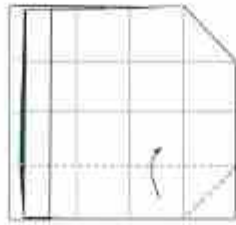

33 - Squash fold

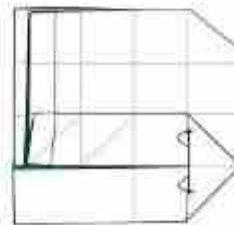

34 - Pull out some hidden paper

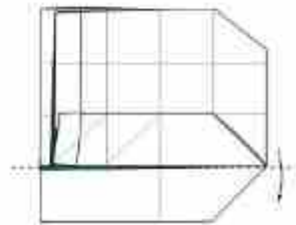

35 - Fold

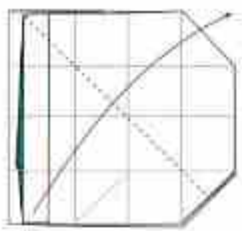

36 - Fold the diagonal

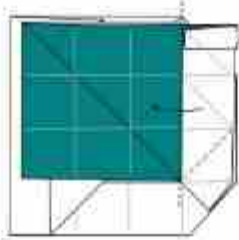

37 - Squash fold

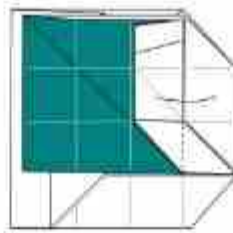

38 - Fold back

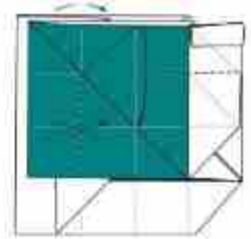

39 - Rabbit ear fold

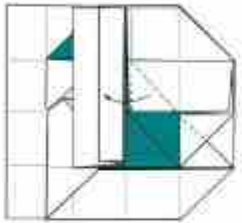

40 - Squash fold

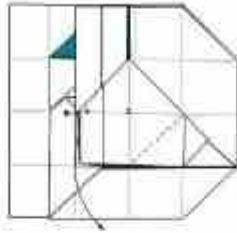

41 - Complex fold: Pull out the flap and pleat using the creases made in Step 26b

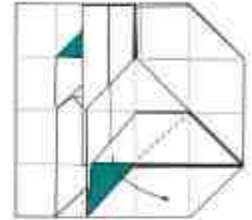
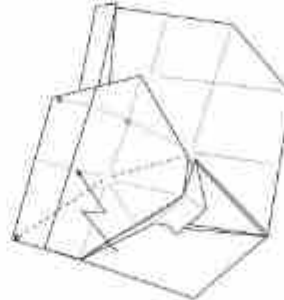

42 - Result. Fold the flap

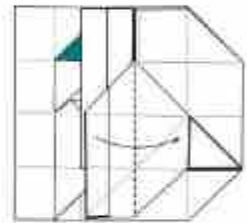

43 - Fold the flap

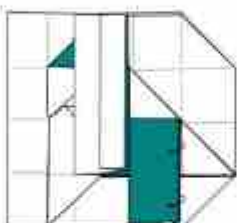

44 - Wrap the layer

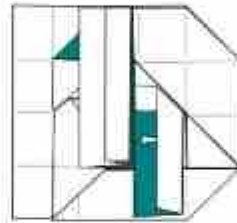

45 - Pull out some paper

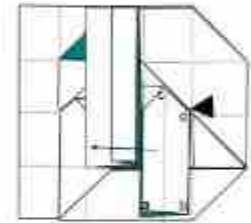

46 - Spread sink

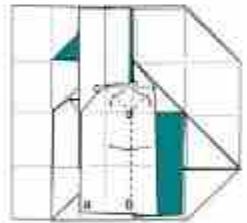

47 - Fold the layer back as shown

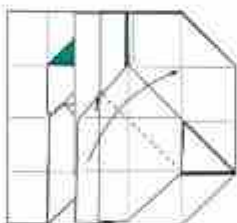

48 - Fold the layer

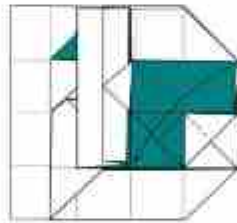

49 - Fold the layer

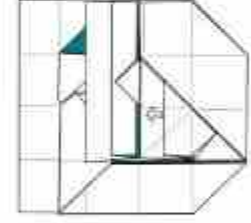

50 - Pull out some paper (unsink)

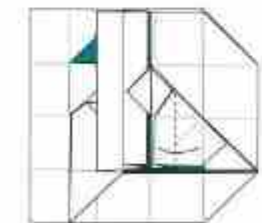

51 - Fold the layer back

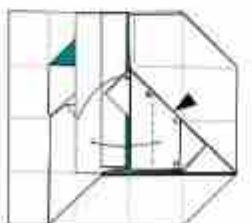

52 - Squash fold & bring the corner "a" as indicated

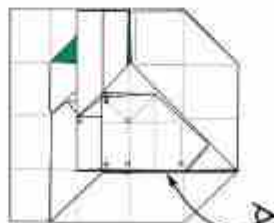

53 - Result. Make a small squash fold as indicated by the arrow

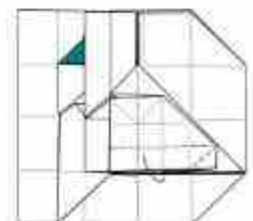

54 - Mountain squash fold

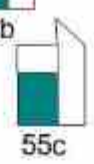
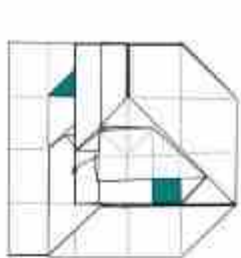

55 - Make a point

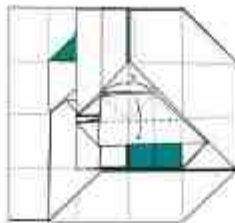

56 - Fold the layer down and bring the circled corners together

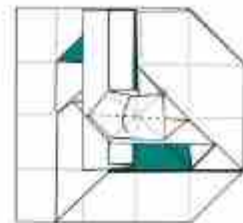

57 - Fold the layer

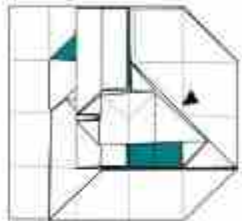

58 - Inside reverse fold and collapse as shown, bringing the circled reference points together

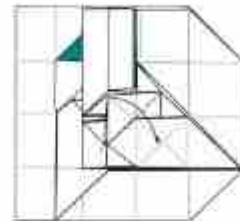
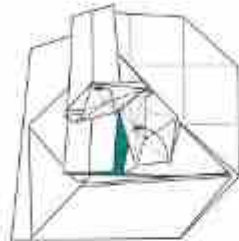

59 - Fold the layer

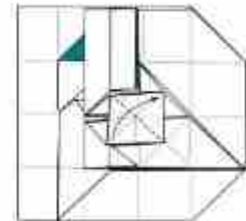

60 - Fold the layer

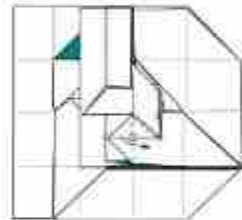

61 - Inside reverse fold (bring the circled points together)

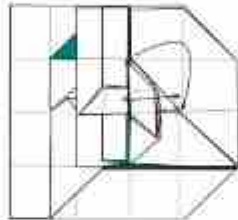

62 - Pull out some paper

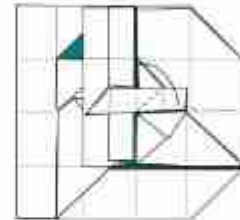

63 - Pleat

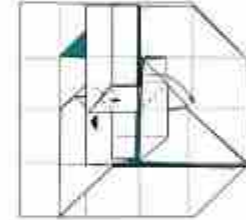

64 - Squash fold for the head. Fold the arm down.

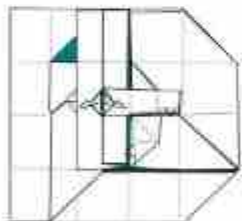

65 - Wrap the layers for the head. Mountain folds

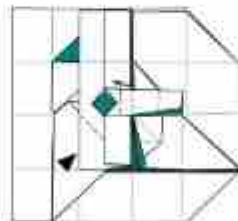

66 - Pleat + Inside reverse fold

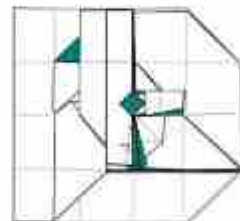

67 - Mountain fold

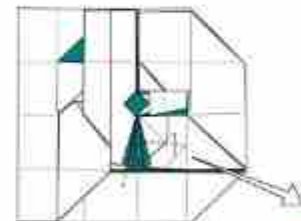

68 - Mountain fold for the leg + Mountain fold on the hidden layer to affine the silhouette

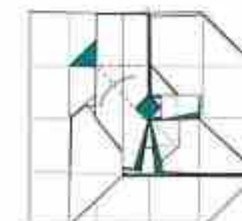

69 - Squash fold

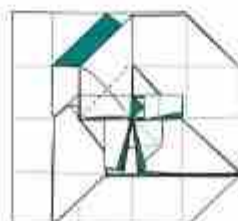

70 - Fold the layer



71 - Mountain fold to create the arm

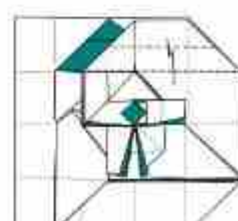

72 - Pleat

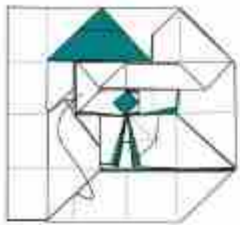

73 - Tuck inside



74 - Wrap the layer



75 - Shape the model

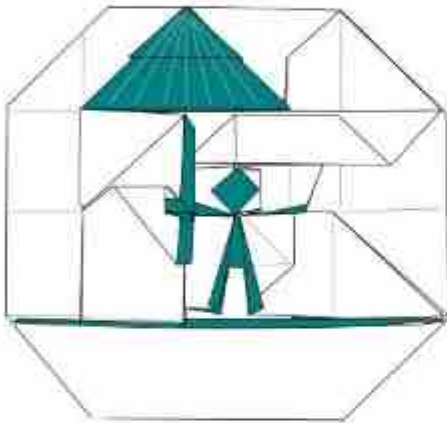

76 - Congratulations.
The model is finished



If you need help, a tutorial can be found there: <https://www.youtube.com/watch?v=W-V9CBQruFk>

Emu

Intermediate

David Ellison

Richard Ellison (dgrms.)

©2022 - USA

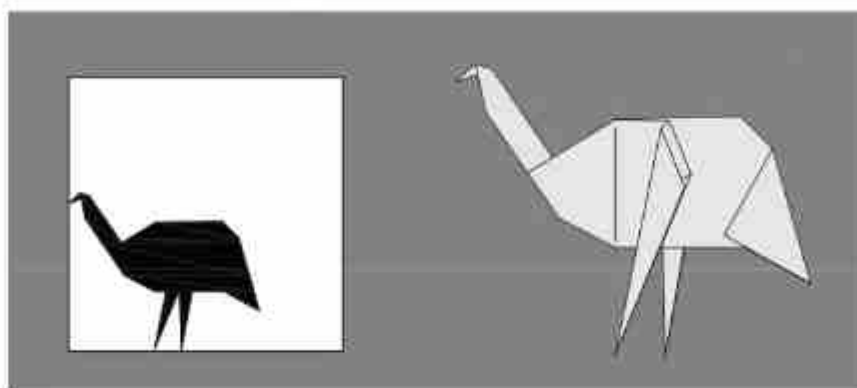

Use a 6" square of paper.

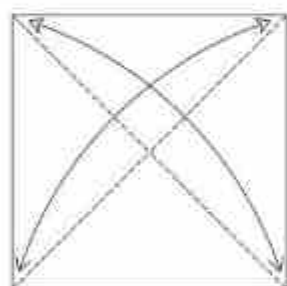

1. If using paper colored on one side only, begin with the white side up. Fold and unfold along both diagonals.

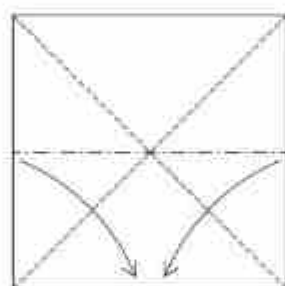

2. Form a Waterbomb Base.

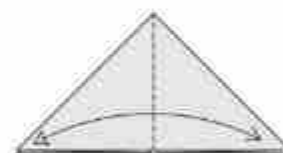

3. Fold and unfold a single flap along its hinge.

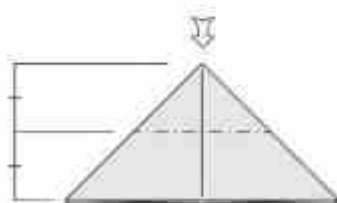

4. Open sink.



5. Swing a single flap over to the right.



6. Valley fold and unfold along an angle bisector through all layers.



7. Valley fold, bringing the circled points together.

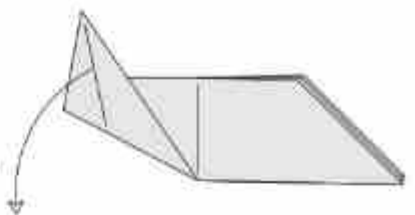

8. Unfold to step 6.



9. Valley fold and unfold through all layers.

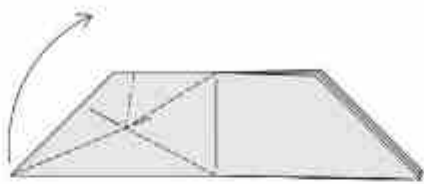

10. Rabbit Ear through all layers.

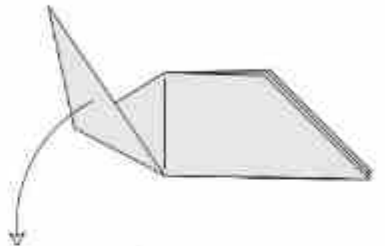

11. Unfold to step 9.

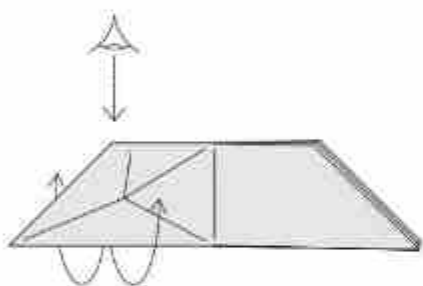

12. Open up the flap to lie nearly flat. The following steps view this flap from the top.

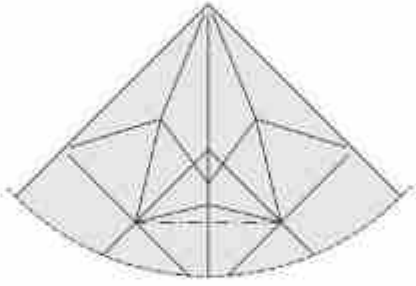

13. Add the indicated mountain crease.

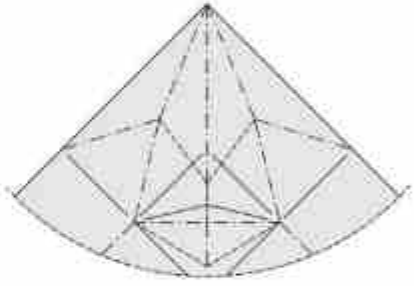

14. Reassign the mountains and valleys as indicated, and collapse the model along these creases.

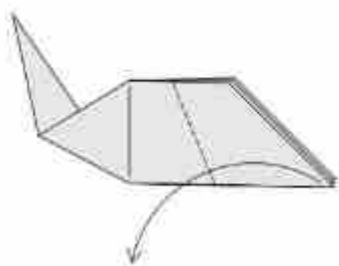

15. Valley fold one layer.

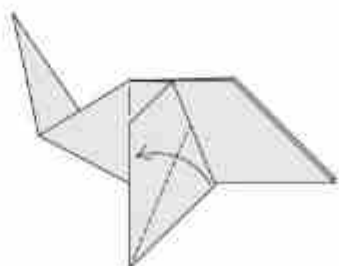

16. Valley fold to make the leg skinnier.

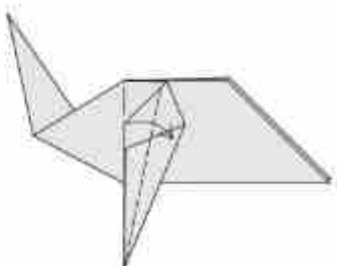

17. Valley fold to make the leg skinnier still.

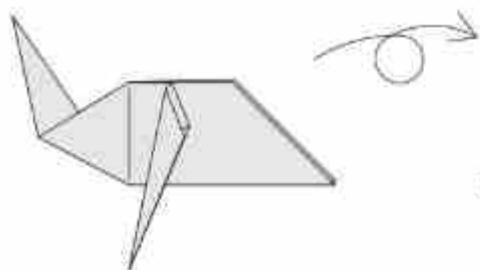

18. Turn the model over from left to right.

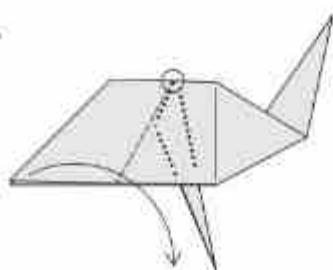

19. Valley fold one layer. Note that the circled landmark aligns with the other leg.

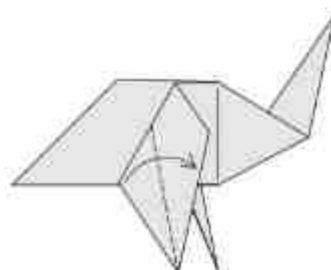

20. Valley fold to make this leg skinnier.

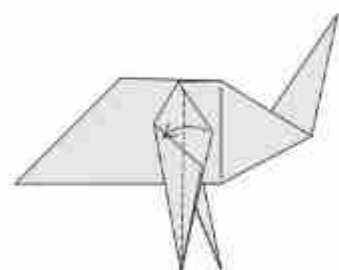

21. Valley fold to make this leg skinnier still.

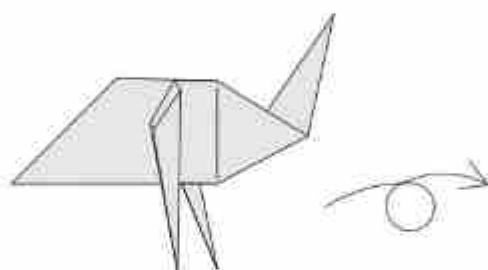

22. Turn the model over from left to right.

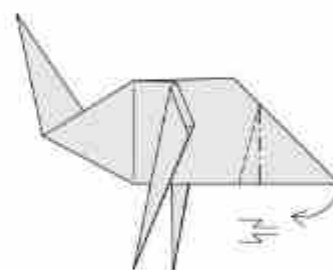

23. Crimp

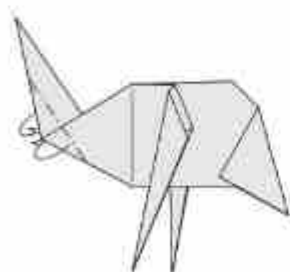

24. Mountain fold the front edges of the bird's chest into the model.



25. Inside reverse fold

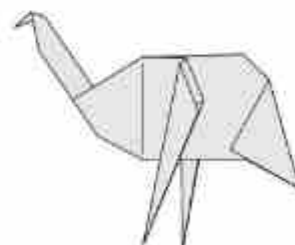

26. The completed Emu

Little Squirrel

Richard Ellison

©2022 - USA

Intermediate

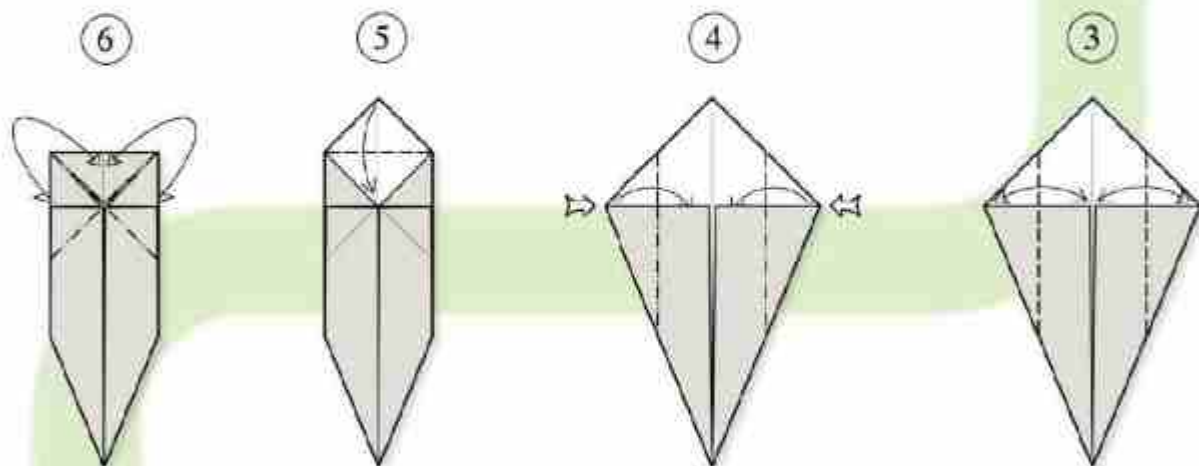
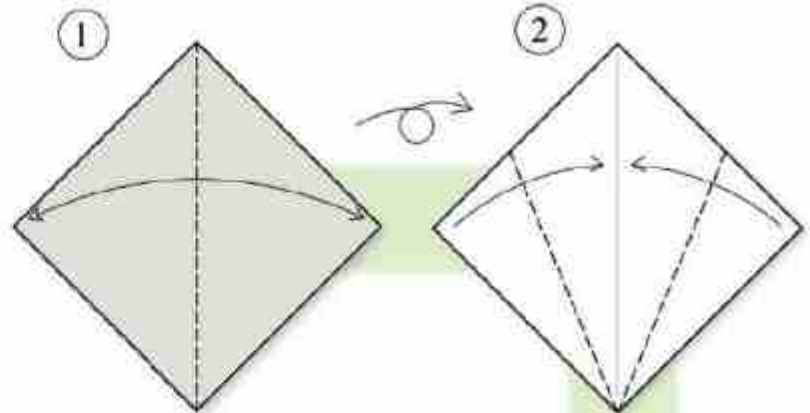
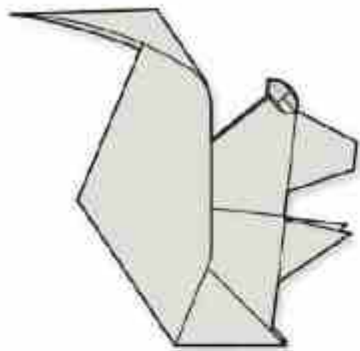

Reverse Fold

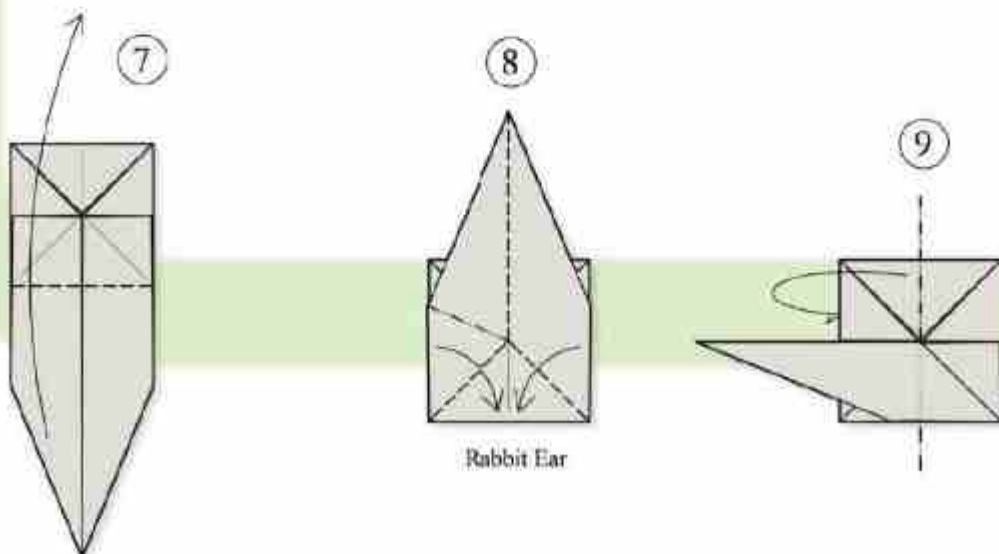

Rabbit Ear

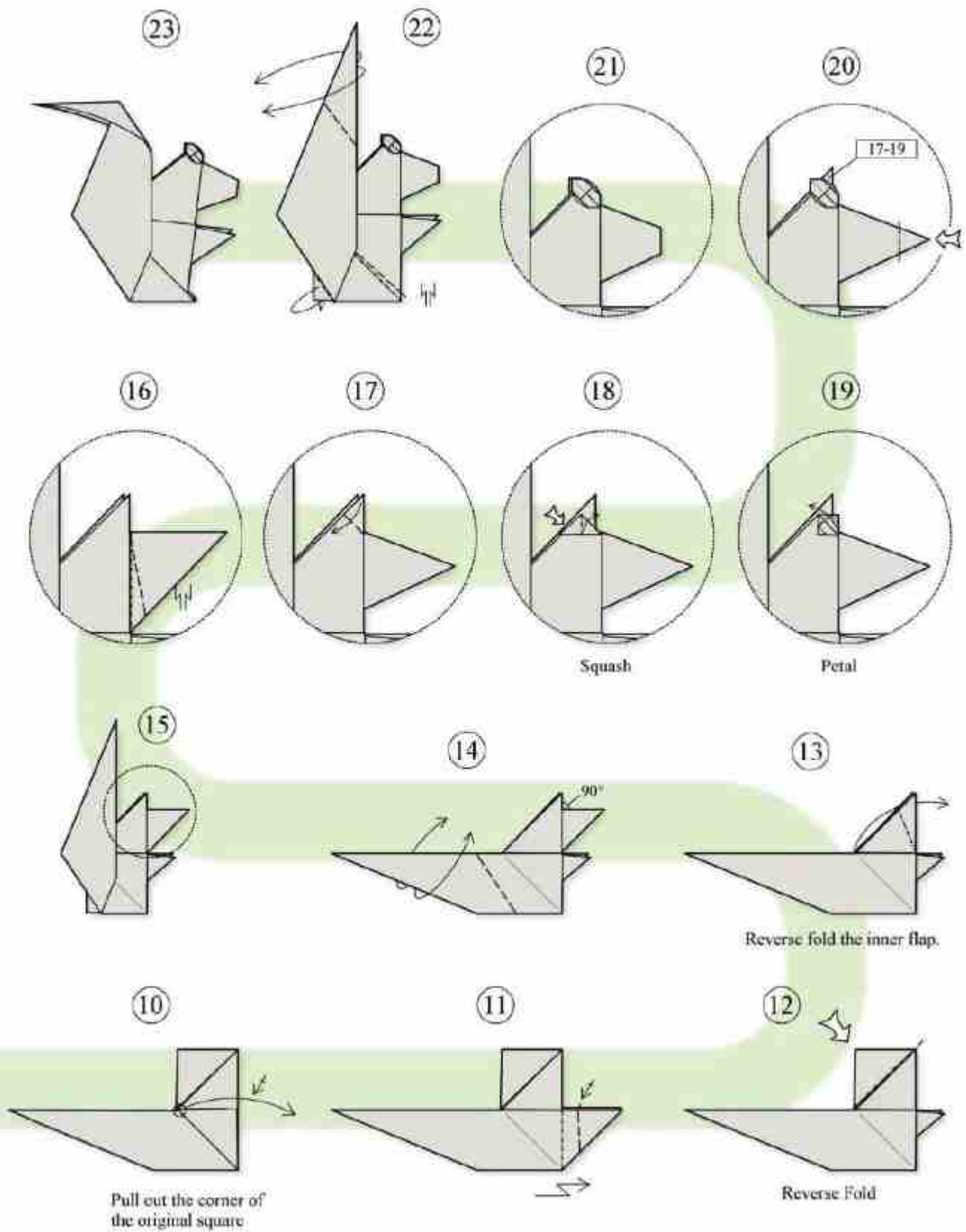

Tiger

High Intermediate

Oriol Esteve

©2021 - Spain

Design: 2021
Recommended paper:
Kami 15-24 cm

Diseño: 2021
Papel recomendado:
Kami 15-24 cm

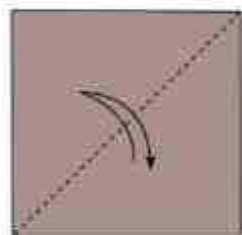
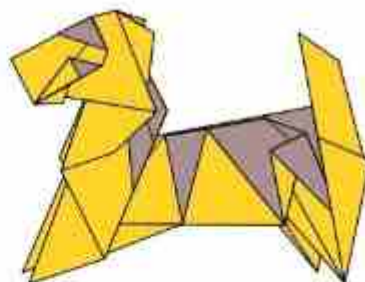

1.

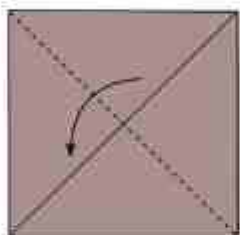

2.

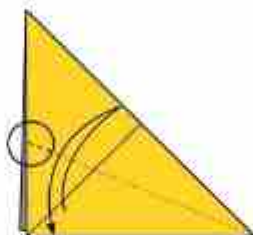

3.

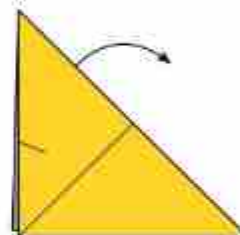

4.

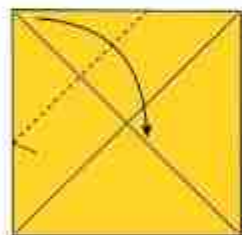

5.

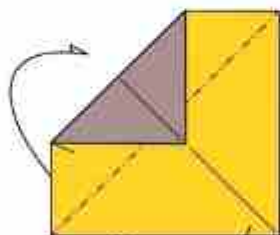

6.

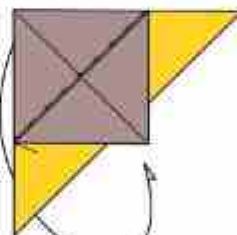

7.

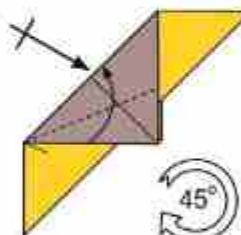

8.

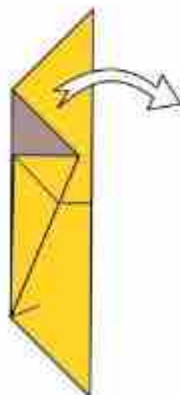

9. Open.
Abrir.

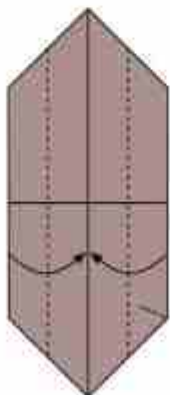

10. Fold this section
(not the flaps on the back).
*Plegar esta sección
(no las solapas de atrás).*

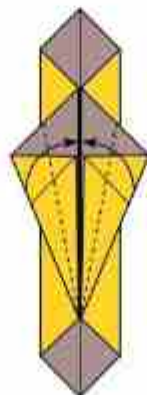

11. Bisect, again.
Bisectar, de nuevo.



12. Release
the pleat.
*Liberar
el plisado.*

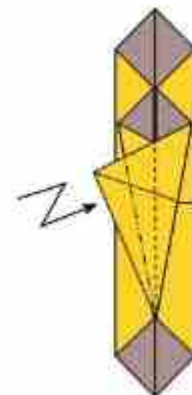

13. Reverse
the pleat.
*Invertir
el plisado.*

12 - 13

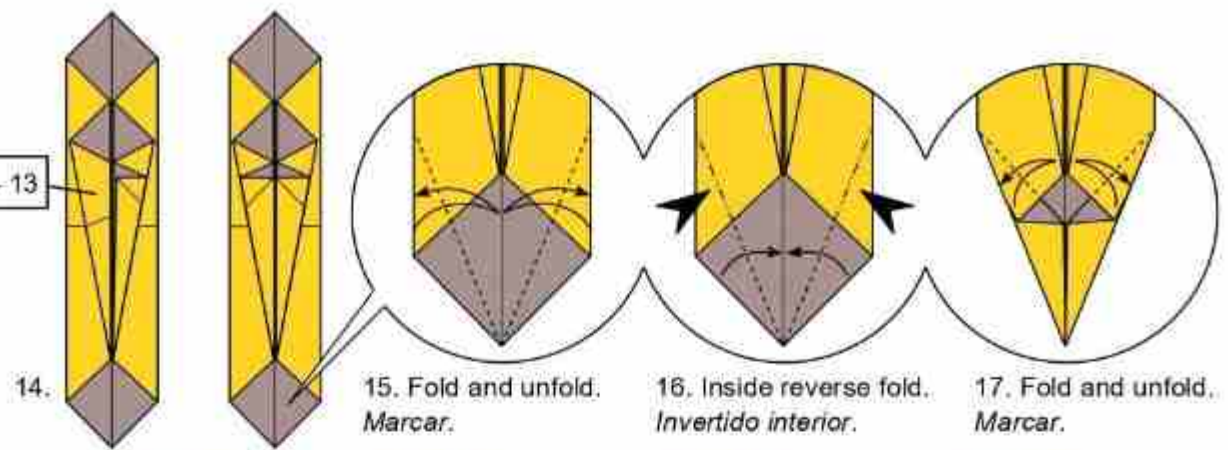

14. 15. Fold and unfold. *Marcar.* 16. Inside reverse fold. *Invertido interior.* 17. Fold and unfold. *Marcar.*

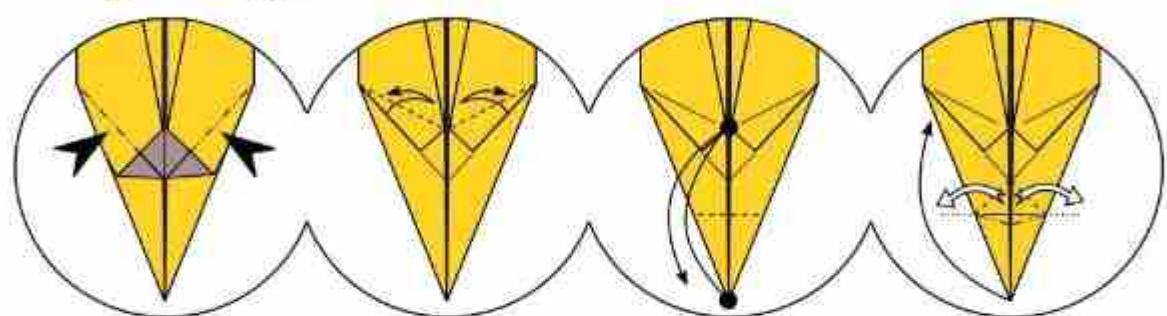

18. Reverse the flap. *Invertir la solapa.* 19. Fold and unfold. *Marcar.* 20. Fold and unfold. *Marcar.* 21. Same fold, spreading the diamond. *El mismo pliegue, pero abriendo el diamante.*

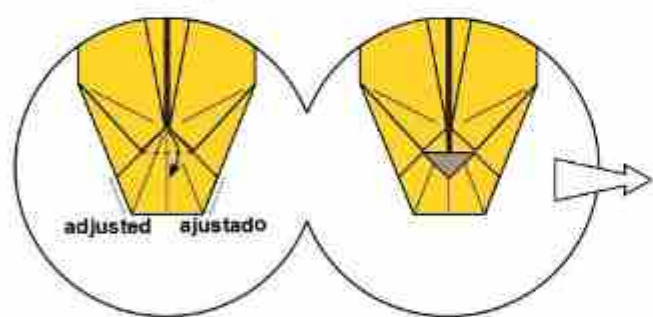

22. Fold the top of the diamond. *Plegar la parte superior del diamante.* 23. Fold and unfold, between references. *Marcar, entre las referencias.*

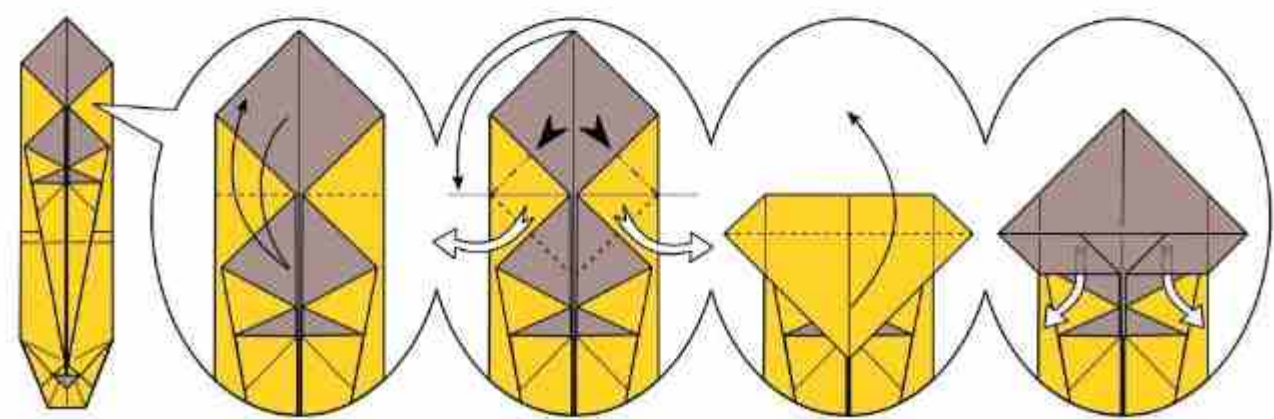

24. Fold and unfold. *Marcar.* 25. Same fold, but spreading flaps. *Mismo pliegue, pero sacando unas puntas.* 26. 27. Release a folded layer. *Liberar una capa que está plegada.*

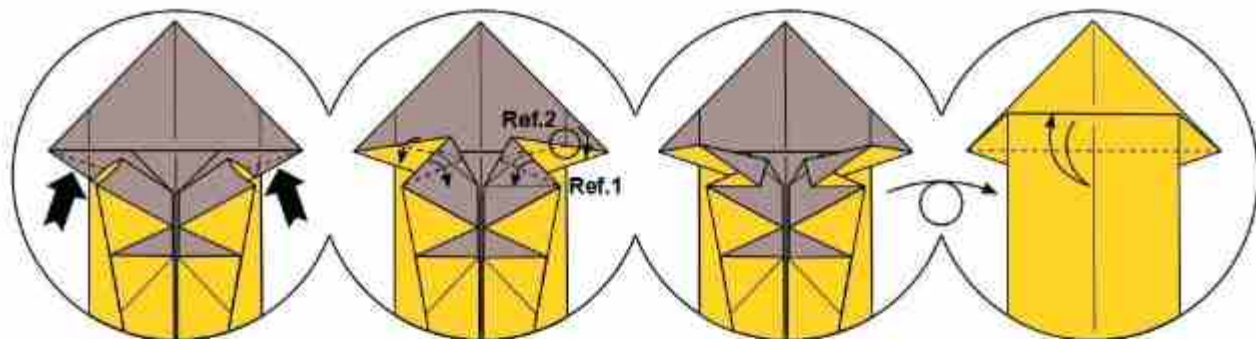

28. Slide the flap until flattened.
Deslizar la capa hasta que quede plana.

29. Swivel, using these two references. "Swivel", siguiendo las dos referencias.

30.

31. Fold and unfold.
Marcar.

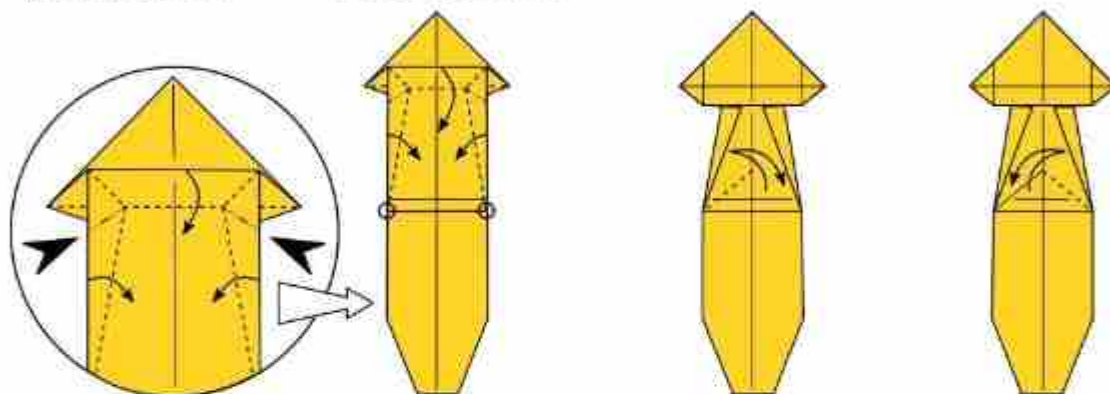

32. Narrow central part. The angle is set by the crease from step 23.
Estrechar la parte central. El ángulo lo determina la marca del paso 23.

33. Fold and unfold.
Marcar.

34. Fold and unfold.
Marcar.

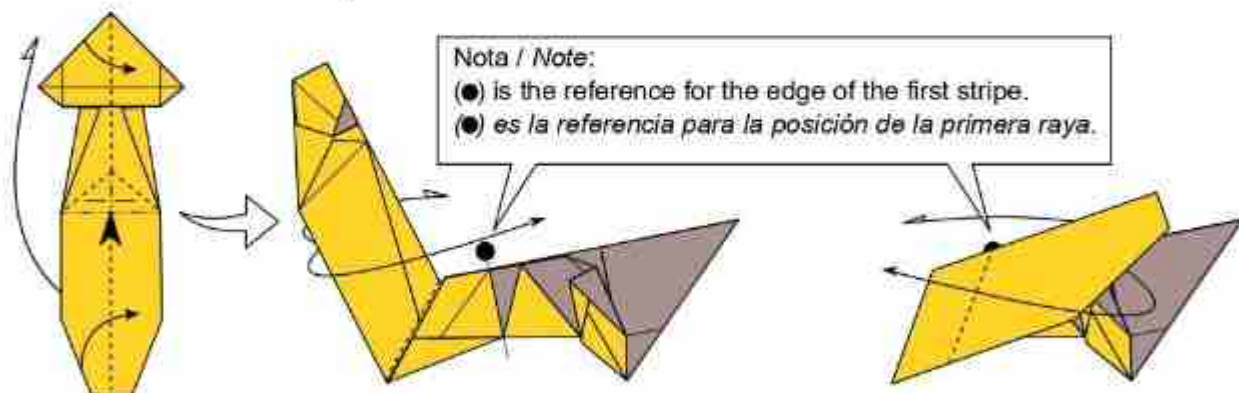

Nota / Note:

● is the reference for the edge of the first stripe.

● es la referencia para la posición de la primera raya.

35. All together.
Plegar todas las marcas.

36. Outside reverse fold.
Invertido exterior.

37. Outside reverse fold.
Invertido exterior.

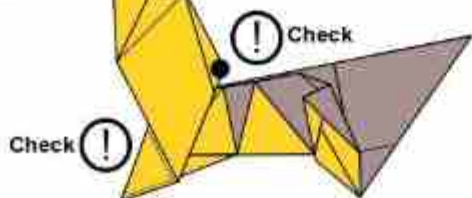

Leg and neck are (close to) a square angle.
Pata y cuello forman (casi) un ángulo recto.

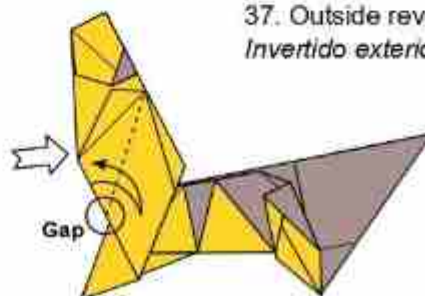

38. Fold and unfold top layer.
Marcar solamente una capa.

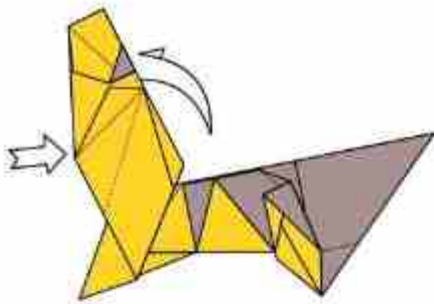

39. Same step on the other side.
El mismo paso, por el otro lado.

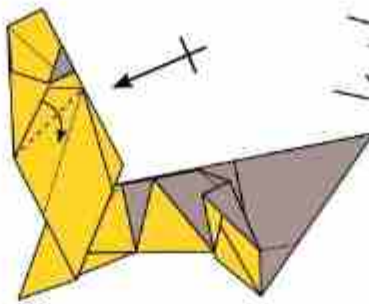

40. Place ears down.
Llevar las orejas abajo.

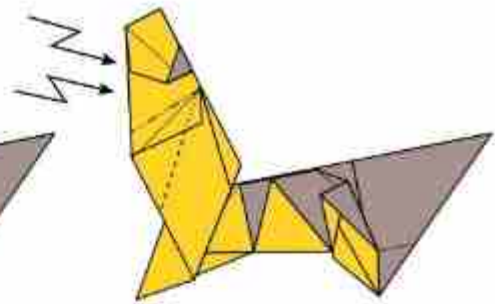

41. Crimp.

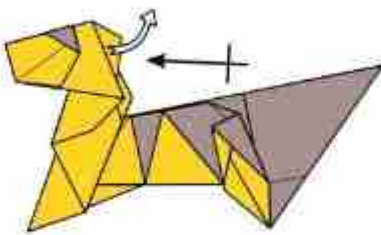

42. Pull ears out, if they are too trapped.
Tirar de las orejas, si están muy escondidas.

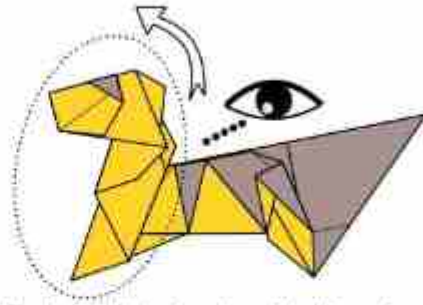

43. Unfold this front part halfway to work on it.
Desplegar un poco para acceder al interior.

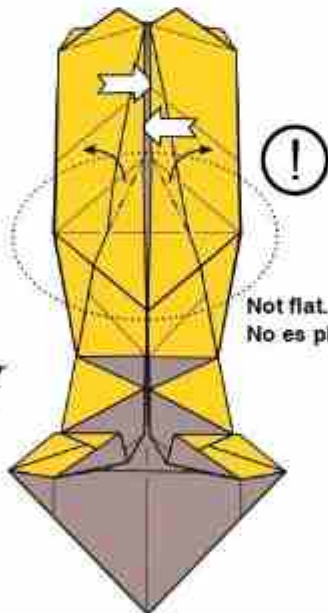

44. Open and slide one layer to create a color change.
Abrir y deslizar una capa para crear el cambio de color.

Not flat.
No es plano.

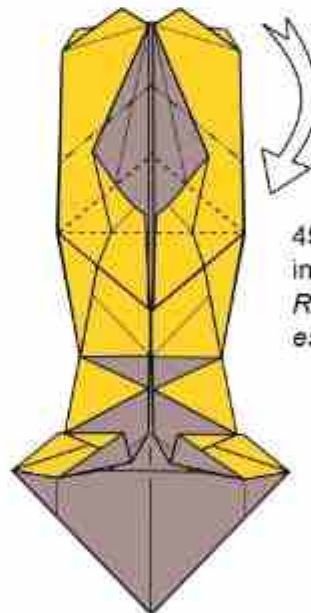

45. Refold as it was in step 43.
Replegar tal y como estaba en el paso 43.

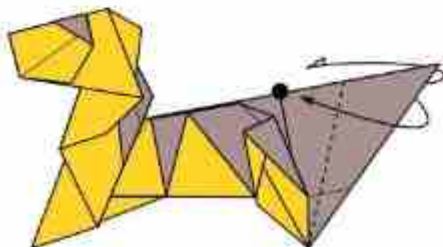

46. Outside-reverse-fold the bisectors.
Invertido exterior de las bisectrices.

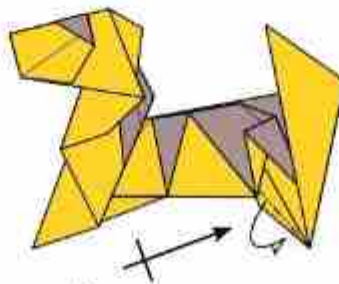

47.

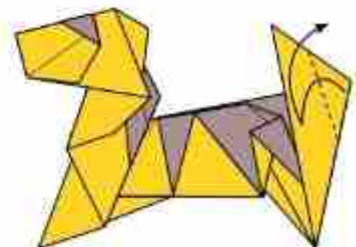

48. Fold and unfold.
Marcar.

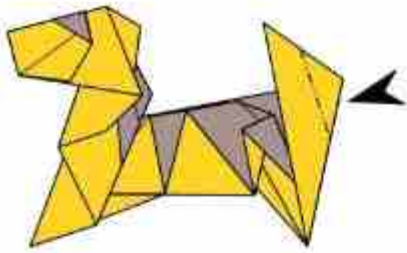

49. Open sink.
Hundido abierto.

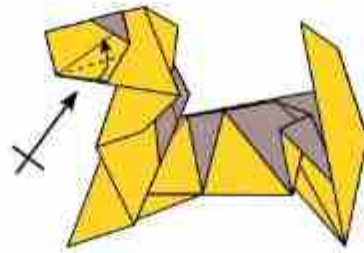

50.

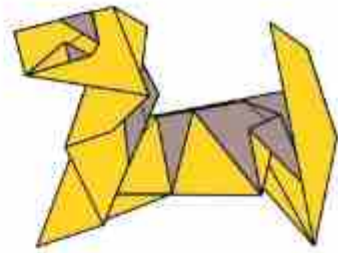

51. Optional: crimp to create a jaw.
Opcional: "crimp" para insinuar la mandíbula.

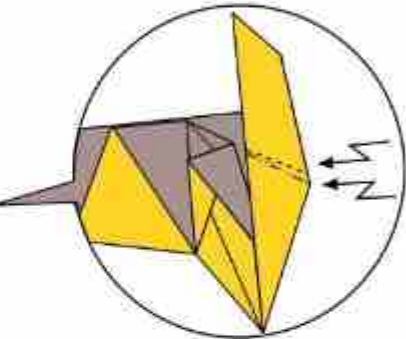
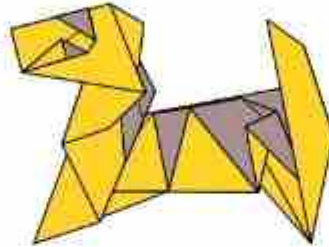

52. Optional: crimp to create a separation between leg and tail.
Opcional: "crimp" para crear una separación entre la pata y la cola.

Done!

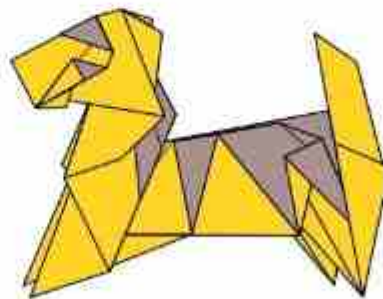

Note: basic shape is completed. But there are two advanced folds to improve the final result.
Nota: la forma básica está terminada. Pero se pueden añadir dos pliegues avanzados.

Witch

Intermediate

Roger Garcia
Ramon Thomas (dgrms.)
©2022 - Spain

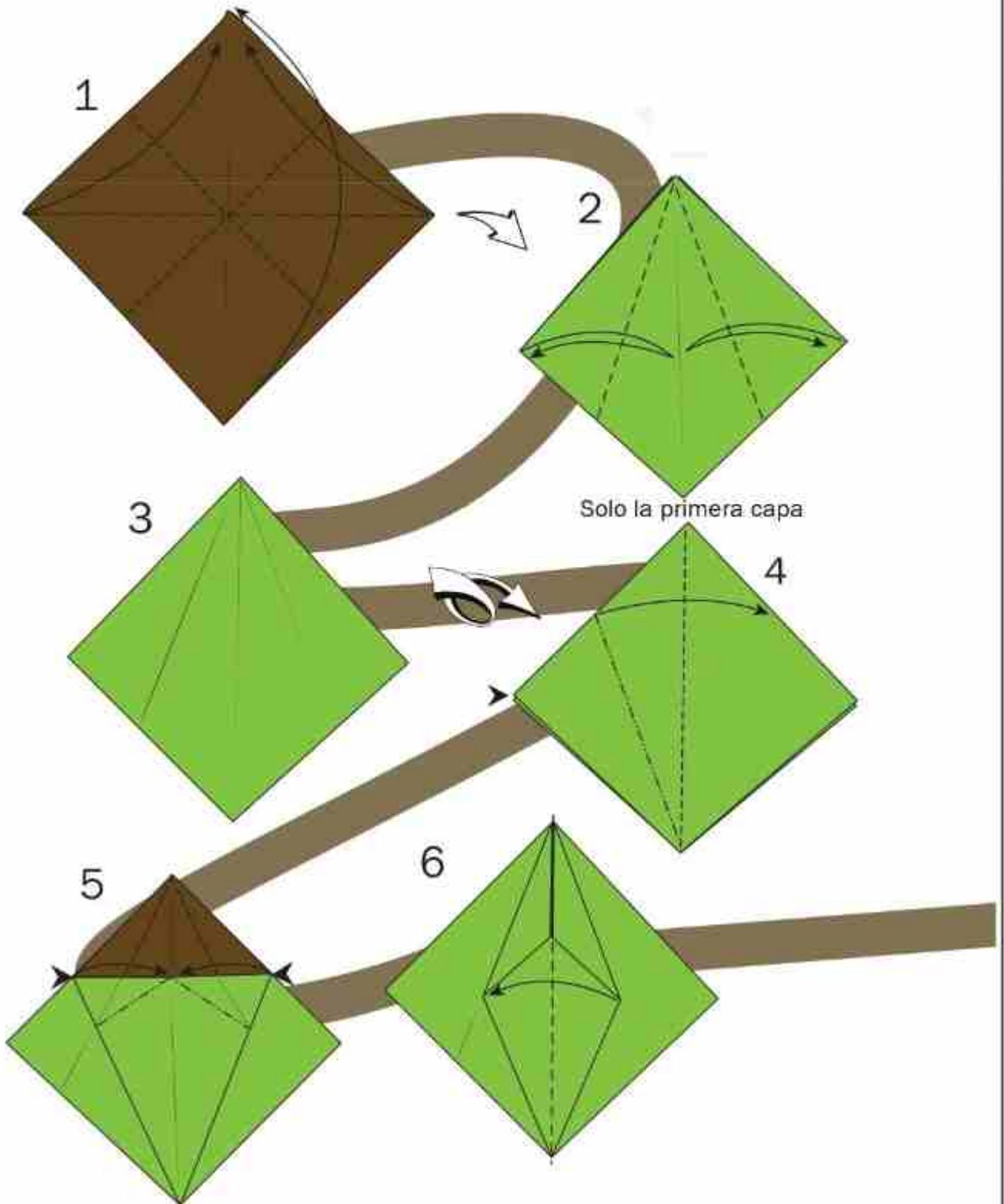

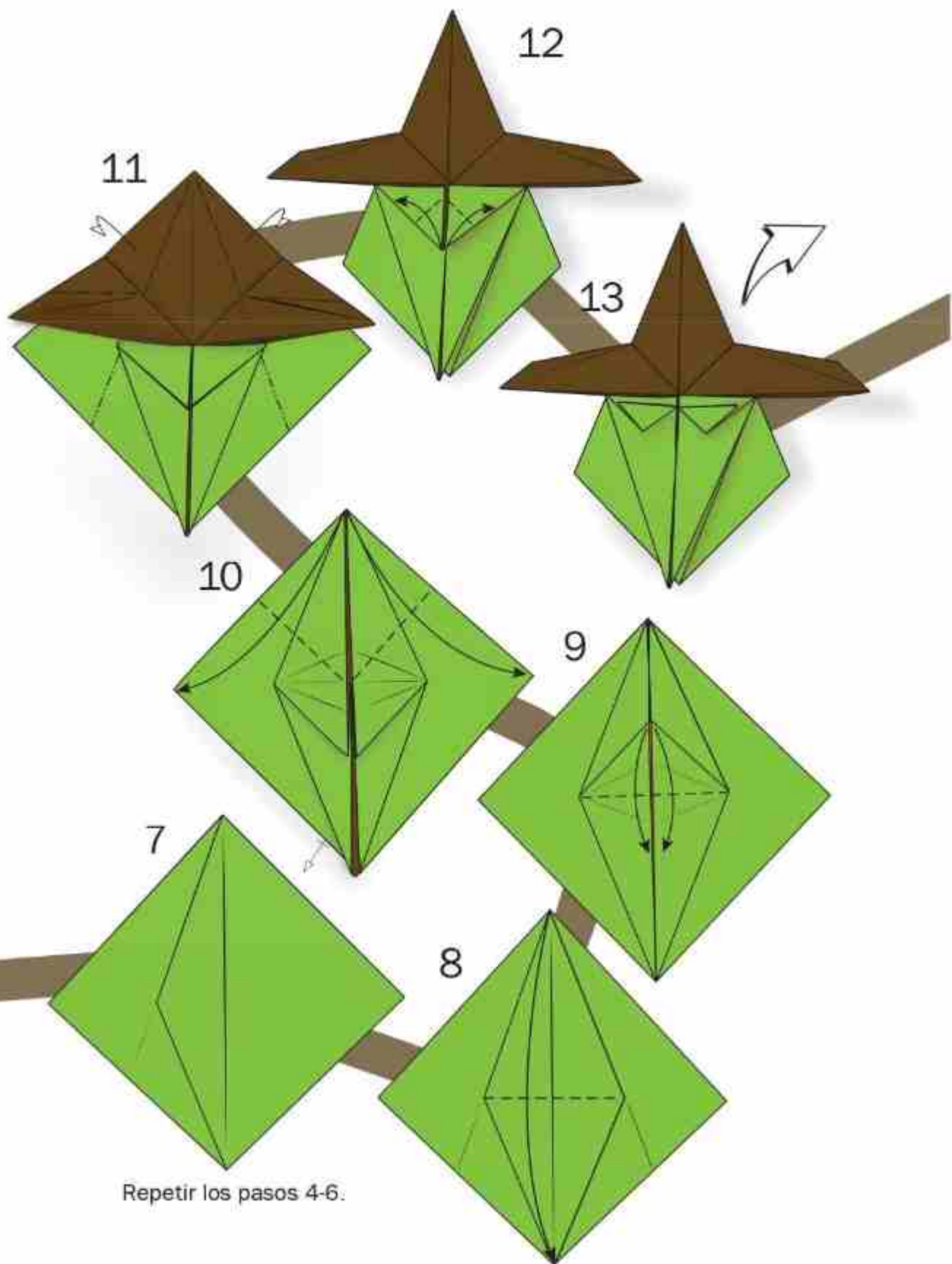

Repetir los pasos 4-6.

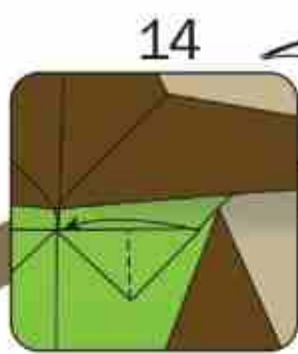

14

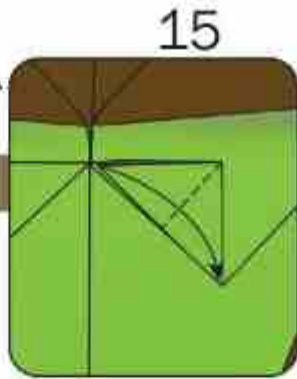

15

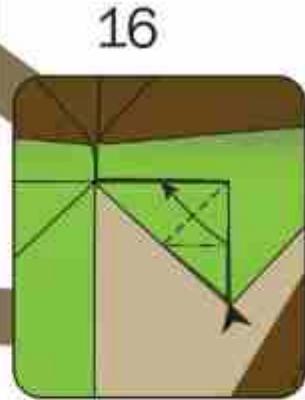

16

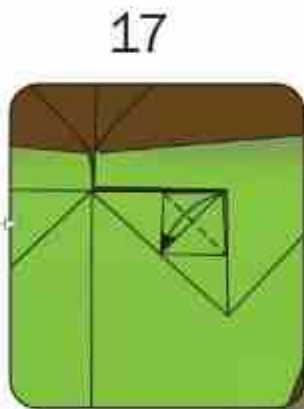

17

Repetir los pasos 14-17.

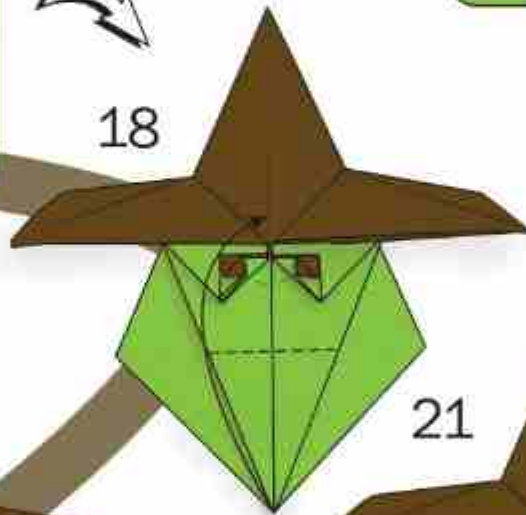

18

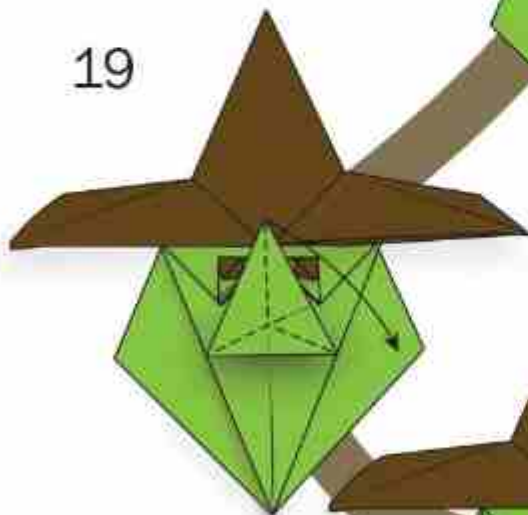

19

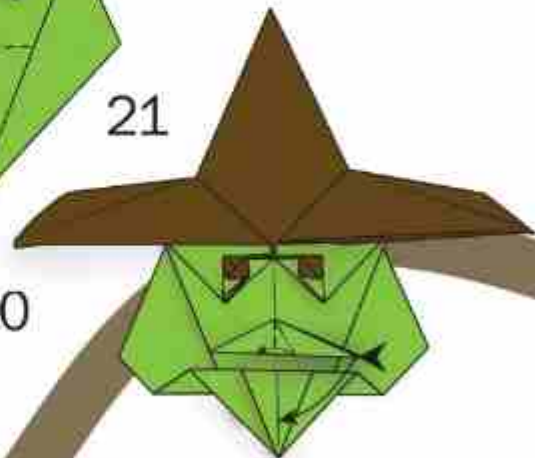

21

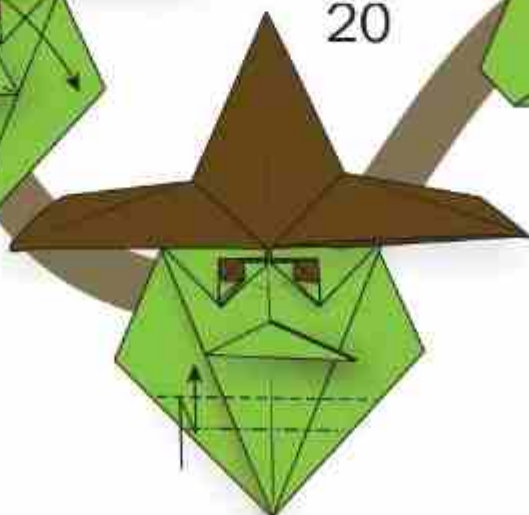

20

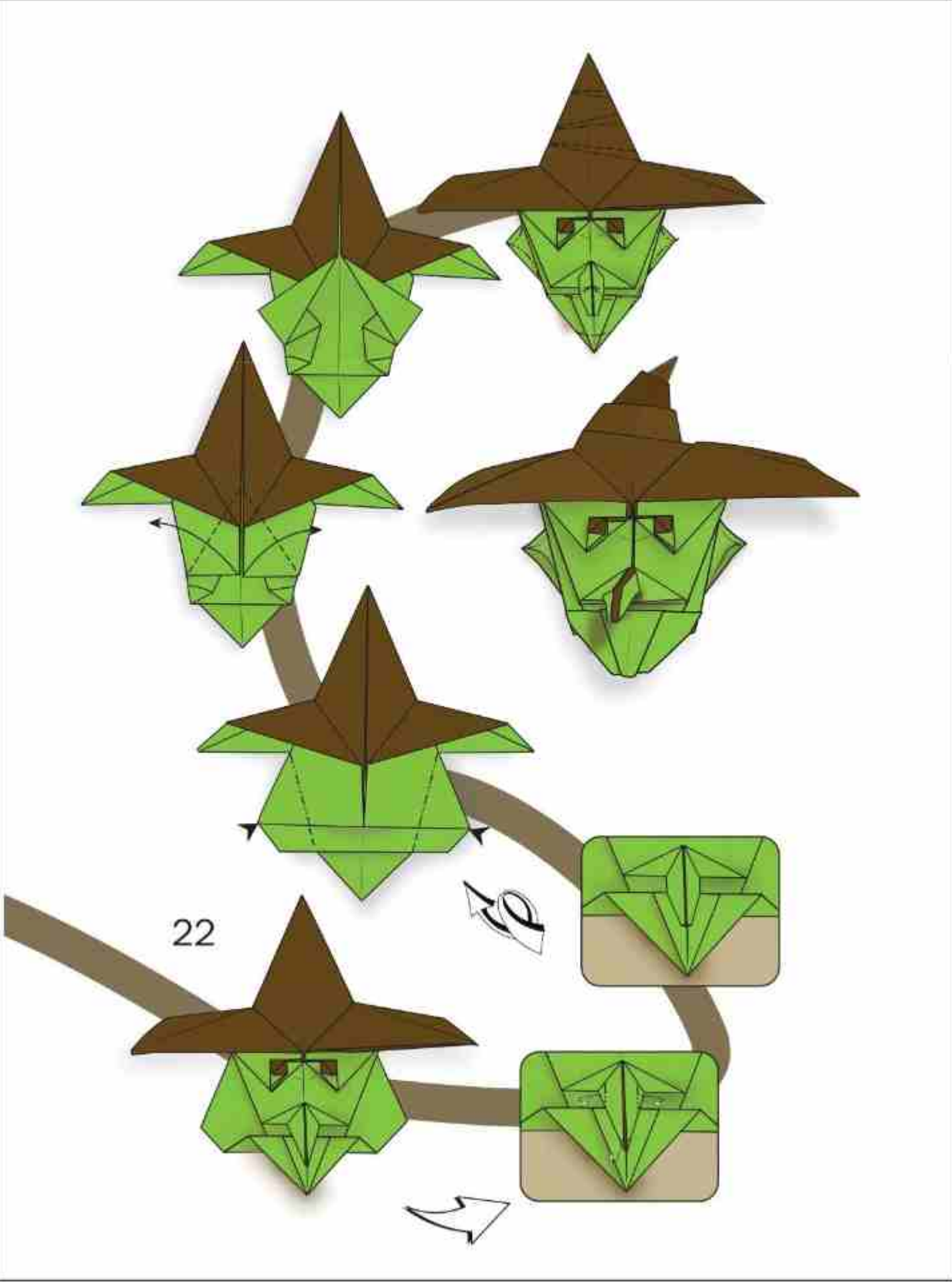

22

Boats

Low Intermediate

Madhura Gupta

©2022 - India

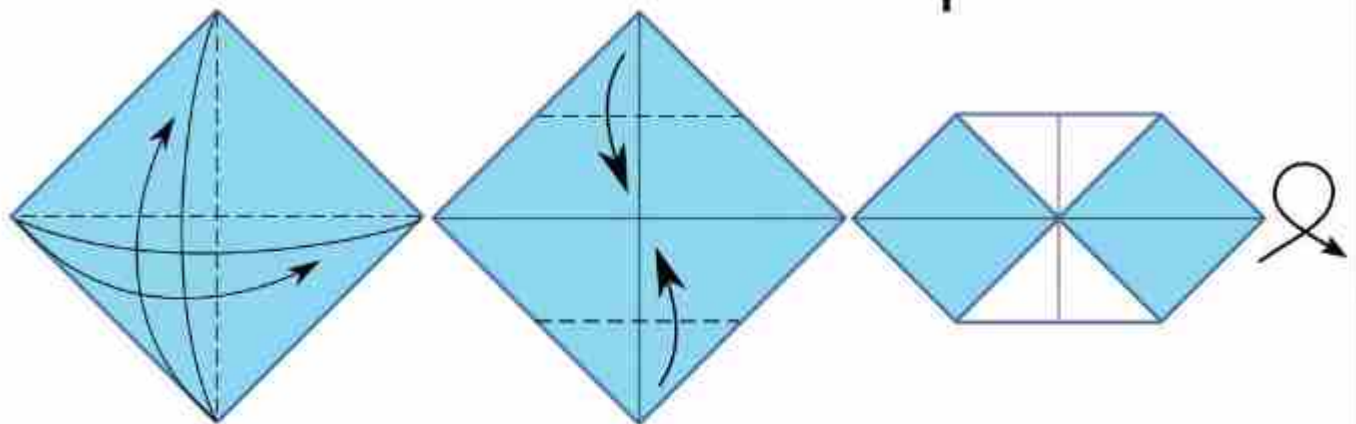

1. Start with the color side up. Fold and unfold the diagonals.

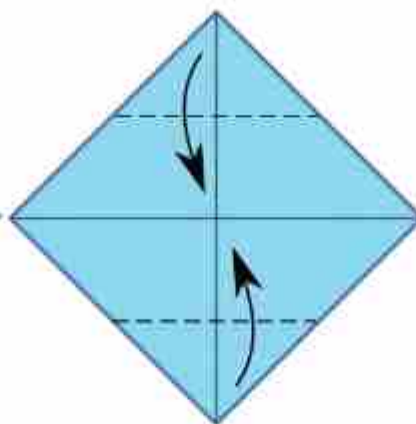

2. Bring the top and bottom corners to the centre. Fold.

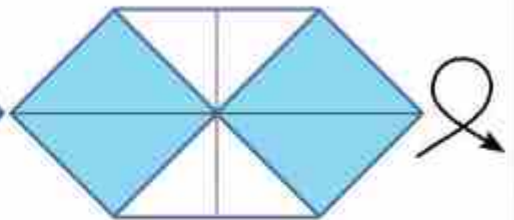

3. Turn the model over.

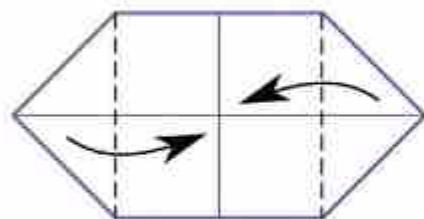

4. Bring the left and right corners to the centre.

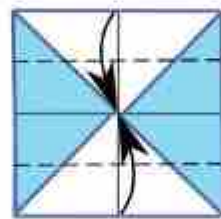

5. Align the lower edge with the central crease. Fold. Do not crease the triangular flap underneath. Repeat on the other side.

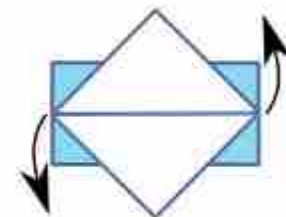

6. This is how it looks. Unfold the last step.

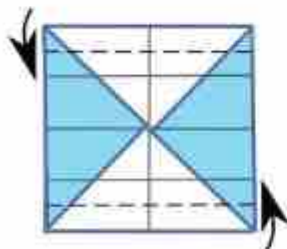

7. Align and crease the lower edge to the crease made in the last step. Repeat on the other side.

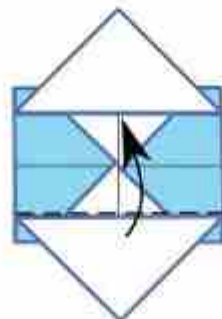

8. This is how it looks. Now fold the bottom edge up.



9. Now bring the tip down - a little below the flap. Tuck it inside the flap.

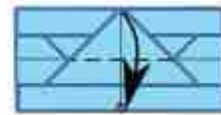
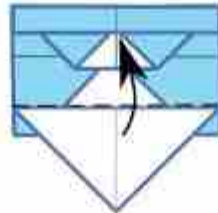
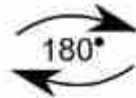
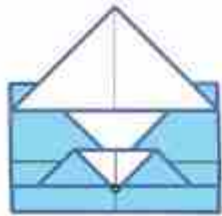

10. This is how it looks. Note how the tip is tucked inside. Now, rotate the model 180 degrees.

11. Fold the lower edge up.

12. Bring the top to the bottom. Fold. Tuck the flap inside.

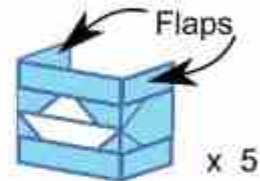
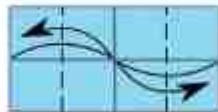

13. Now turn the model over.

14. Bring the left and right edges to the centre. Fold and unfold.

One complete unit. Make 5 more.

Assembly

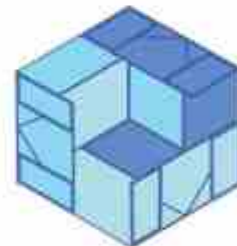
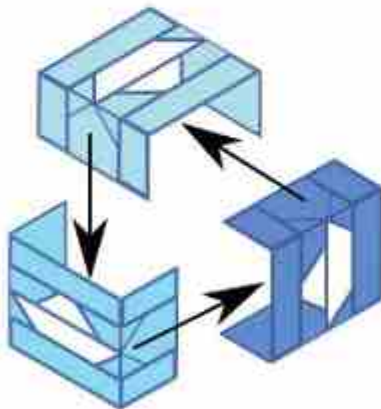

1. Take 3 units. Place them at right angles to each other. Now, slide the flap of one unit underneath the face of the other unit. Join 3 units to make one corner of the cube.

2. This is how it looks. Turn over.

3. This is how the model looks from the diagonally opposite side.

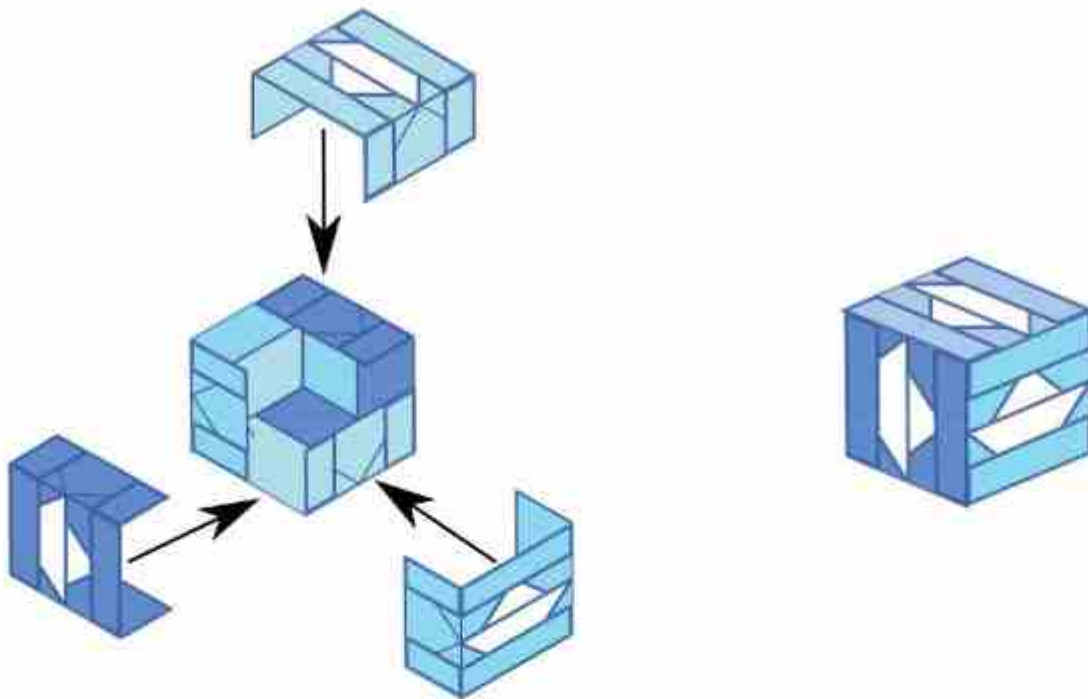

4. Add the remaining 3 units in a similar manner. Always make sure the flaps of one unit go underneath the faces of the other units.

The complete cube
Boats

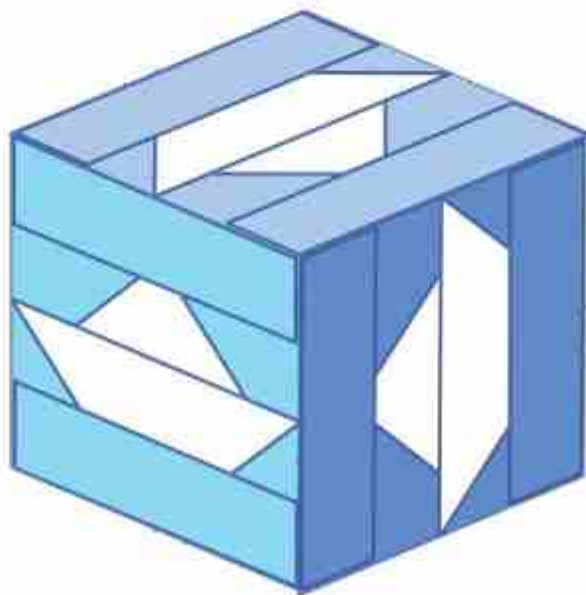

Hand

Intermediate

Bodo Haag

©2023 - Germany

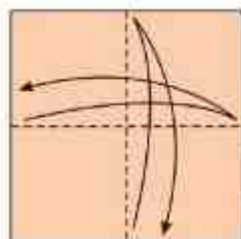

1: Fold and unfold

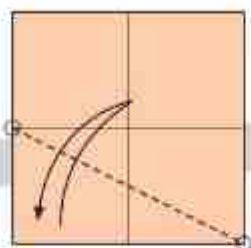

2: Connect the marked points. Fold and unfold

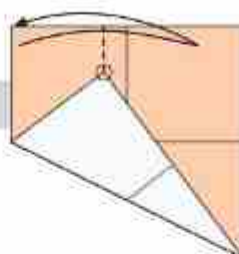

3: Pinch the top edge using the white corner as a reference

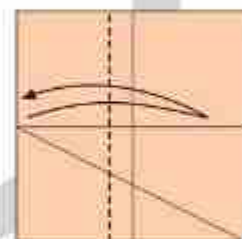

4: Extend the line made in step 3. make sure its perfectly vertical

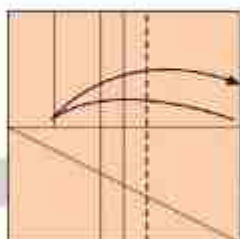

5: Fold and unfold.

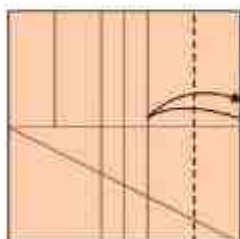

6: Fold and unfold.

7: Fold and unfold.

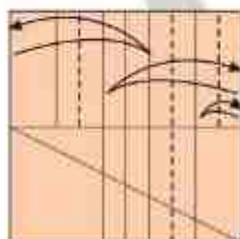

8: Fold and unfold.



9: Fold the diagonals using the marked points.

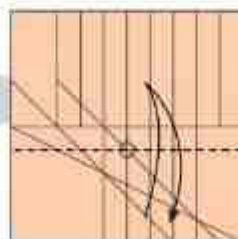

10: Fold and unfold.

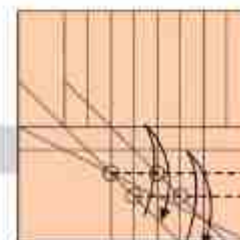

11: Fold and unfold.

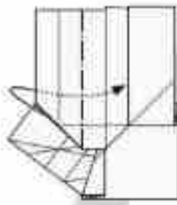

24: Inside reverse fold again.

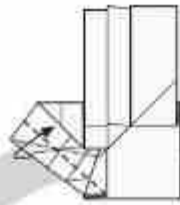

25: Fold the edge over.

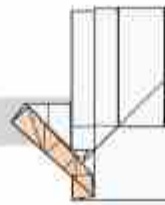

26: The result. Turn over.

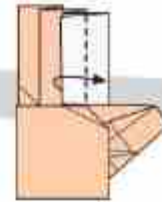

27: Fold the edge to the right.



23: Inside reverse fold.

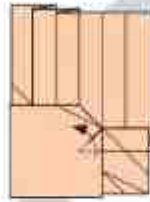

19: Fold the hidden edge to the left.

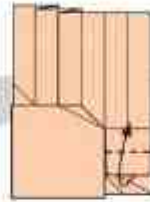

18: Fold the edge up.

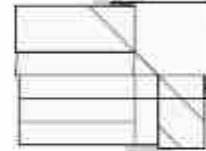

17: The result. Turn over.

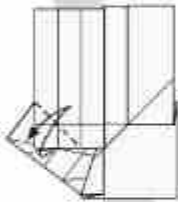

22: Fold and unfold.



20: Shift the paper up.

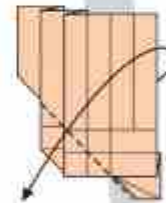

16: Fold the corner up while swinging the paper out.

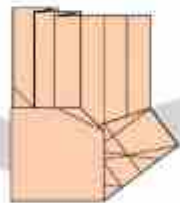

21: The result. Turn over.

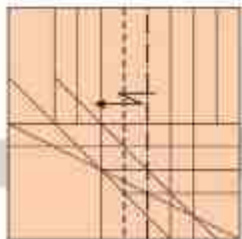

12: Pleat as shown.

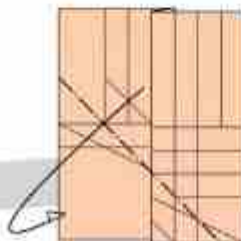

13: Fold the corner behind.

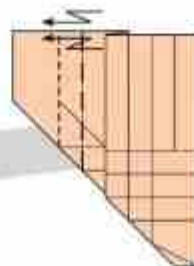

14: Inside reverse fold in and out.

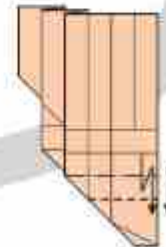

15: Inside reverse fold in and out.

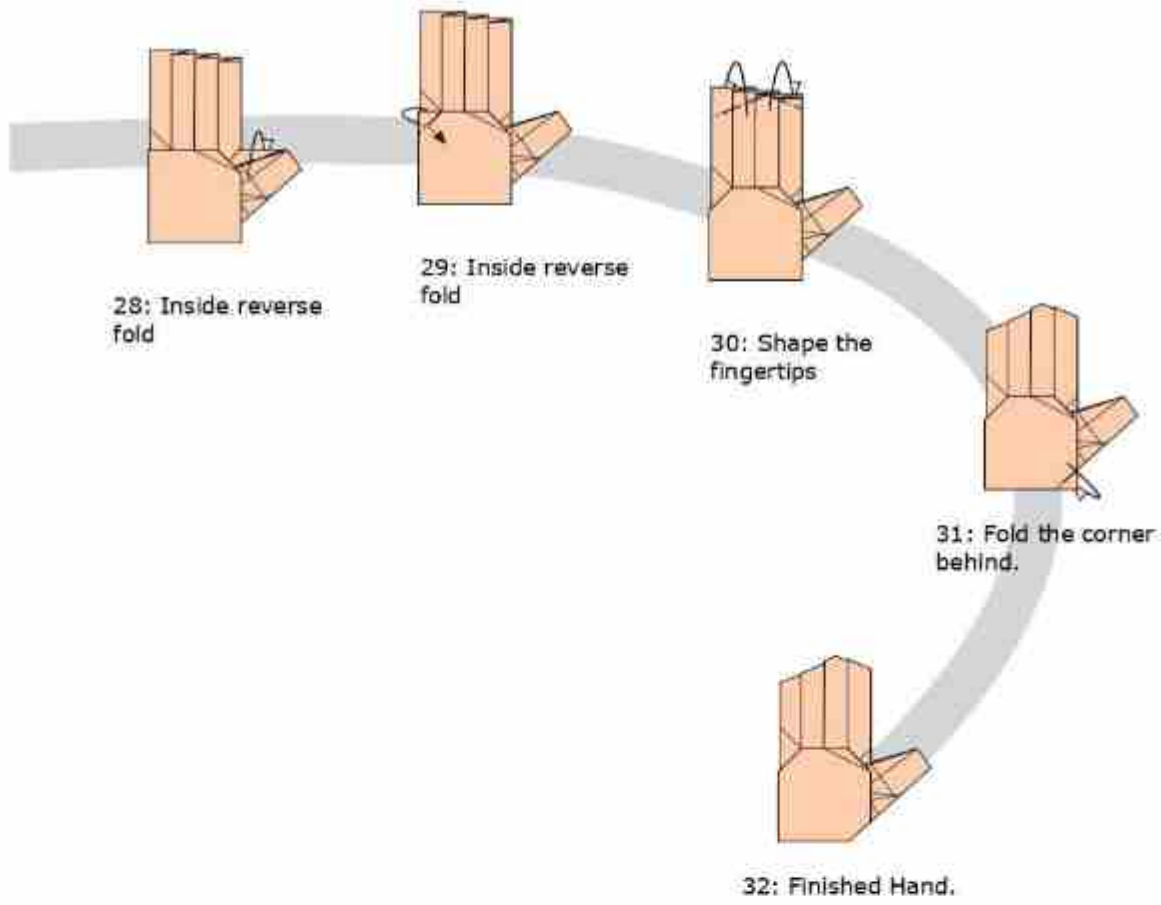

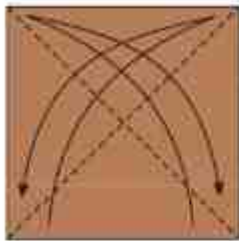

1: Fold and unfold.

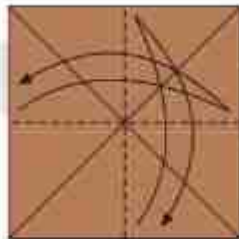

2: Fold and unfold.

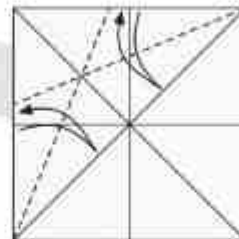

3: Fold the edges to the crease line and unfold.

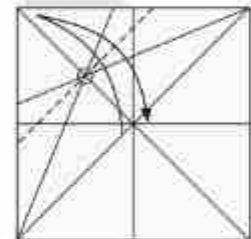

4: Fold and unfold at the circled point.

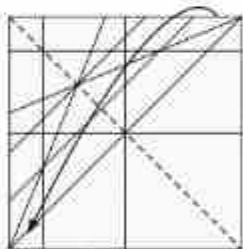

7: Fold diagonally in half.

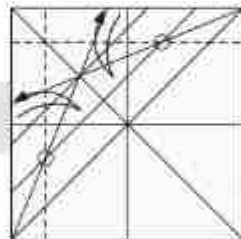

6: Fold and unfold using the circled point.

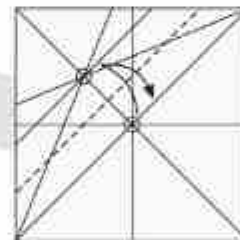

5: Fold and unfold so that the circled points will be on top of each other.

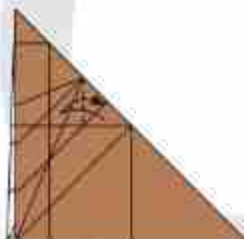

8: Fold the edge to the crease line.

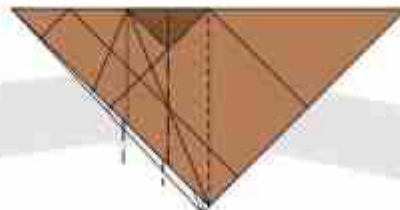

9: Push in the darkened area and pleat.

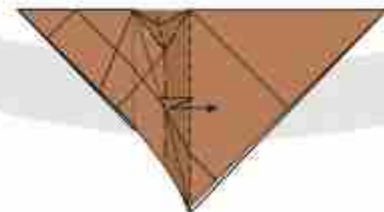

10: Fold the front pleat to the right and the hind one to the left.

12-16

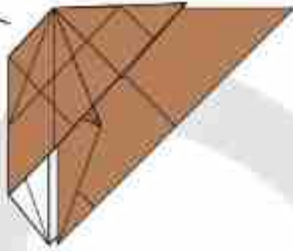

18: Repeat step 12-16 on this side.

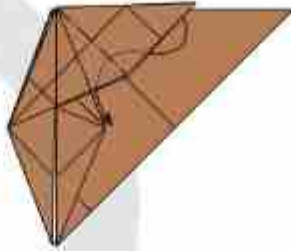

19: Inside reverse fold.

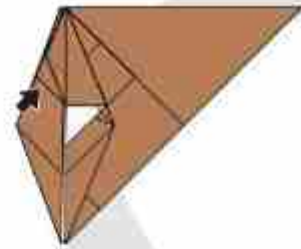

22: Inside reverse fold.

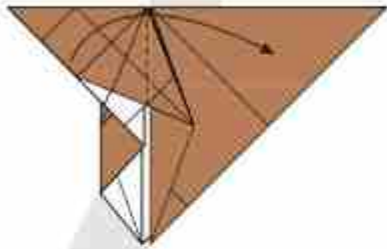

17: Fold the flap to the side.

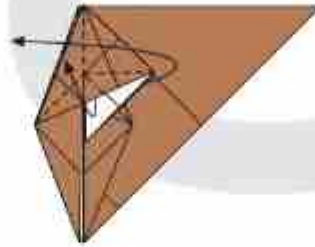

20: Raise the edge and fold the flap over.

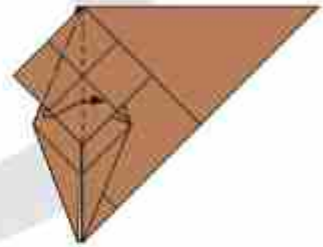

21: Squash.

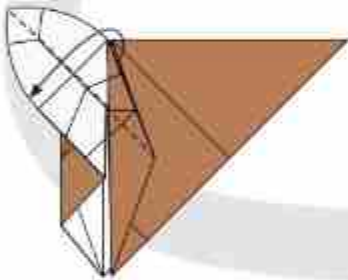

16: Fold the edge down.

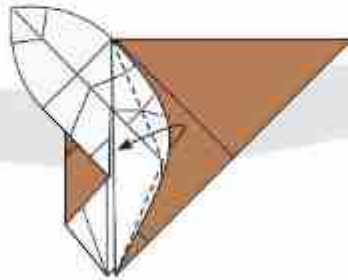

15: Fold the edge to the middle line.

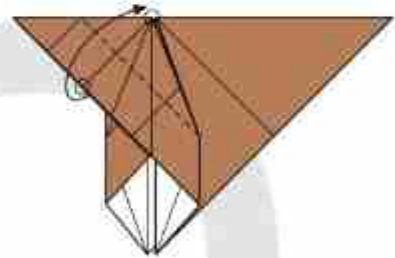

14: Fold so that the circled points will be on top of each other. The model will not lie flat.

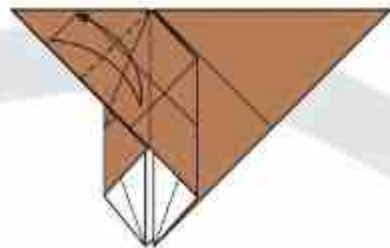

11: Fold the edge to the crease line.

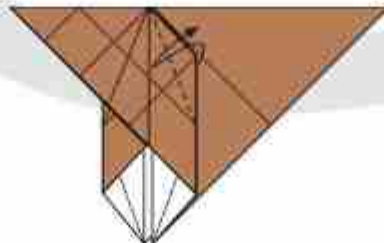

12: Fold the edge to the crease line.

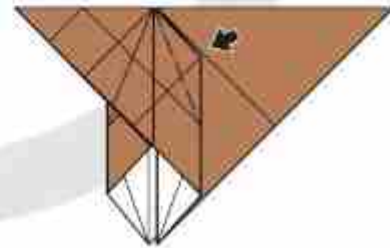

13: Open sink.



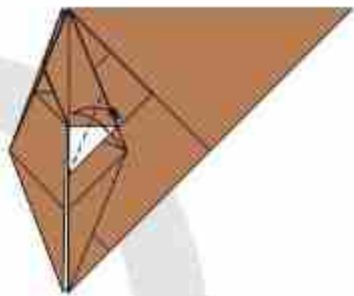

23: Fold the edge to the middle.

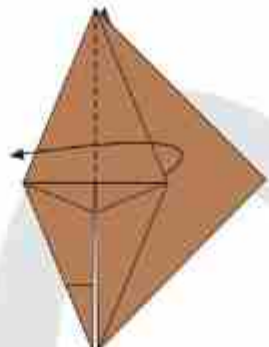

34: Fold the flap over.

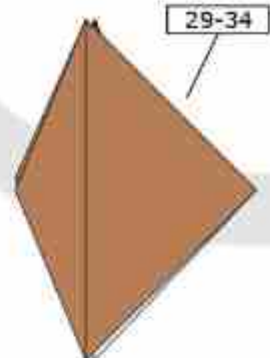

35: Repeat step 29-34 on the other side.

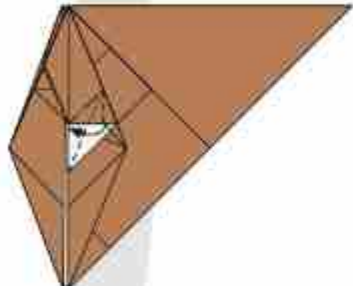

24: Inside reverse fold.

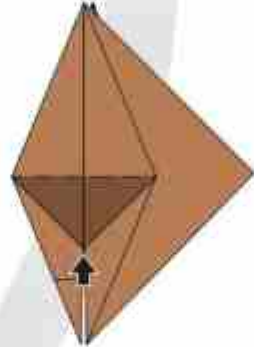

33: Fold the darkened area inside.

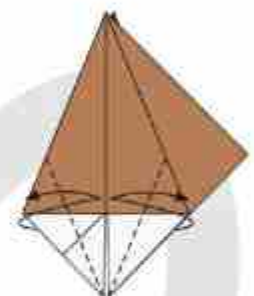

30: Fold the edges to the center and unfold.

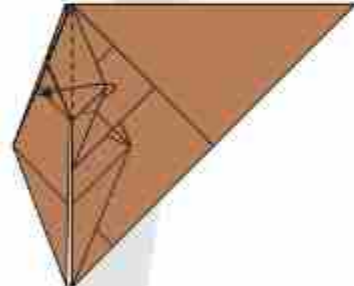

25: Fold the flap over.

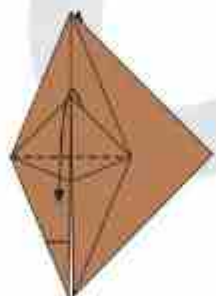

32: Fold the flap down.

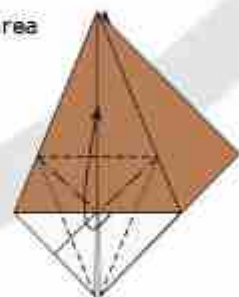

31: Petal fold.

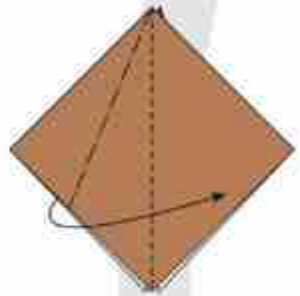

29: Squash.

20-25

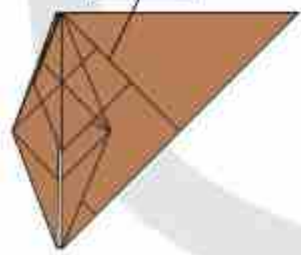

26: Repeat step 20-25 on the other side.

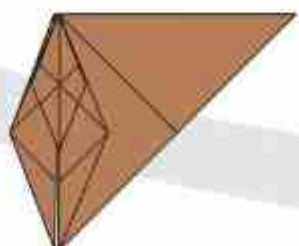

27: The result. Turn over.

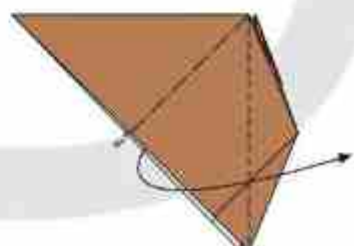

28: Squash.

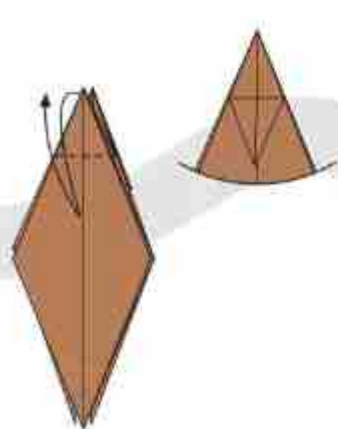

36: Fold the flap as far down as possible and unfold.

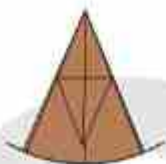

37: Fold the flap down .



38: Fold the both edges in half simultaneously .



39: Valley fold the inner hidden flap.

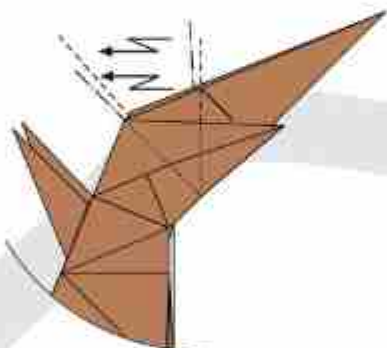
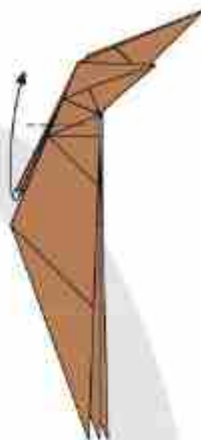

41: The result. Zoom in.

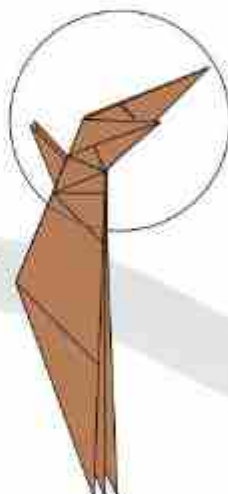

42: Crimp the flap inside.

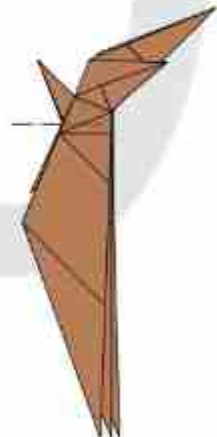

40: Inside reverse fold the other hidden flap, moving it so that the two flaps are separated.

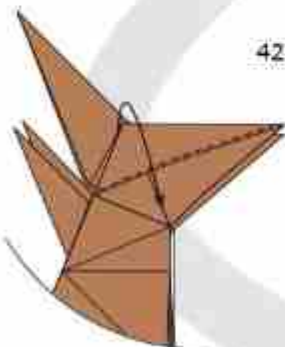

43: Fold the flap along the edge.

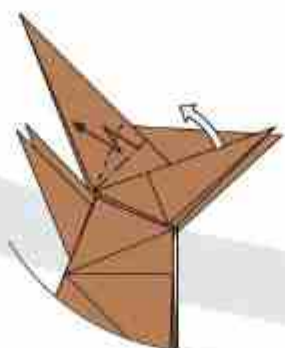

44: Pull out paper from behind and pleat.

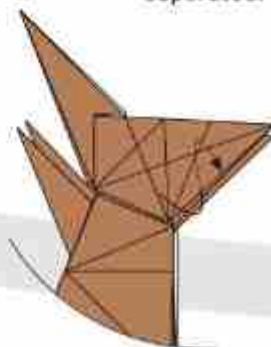

45: Insert the flap in the pocket behind.

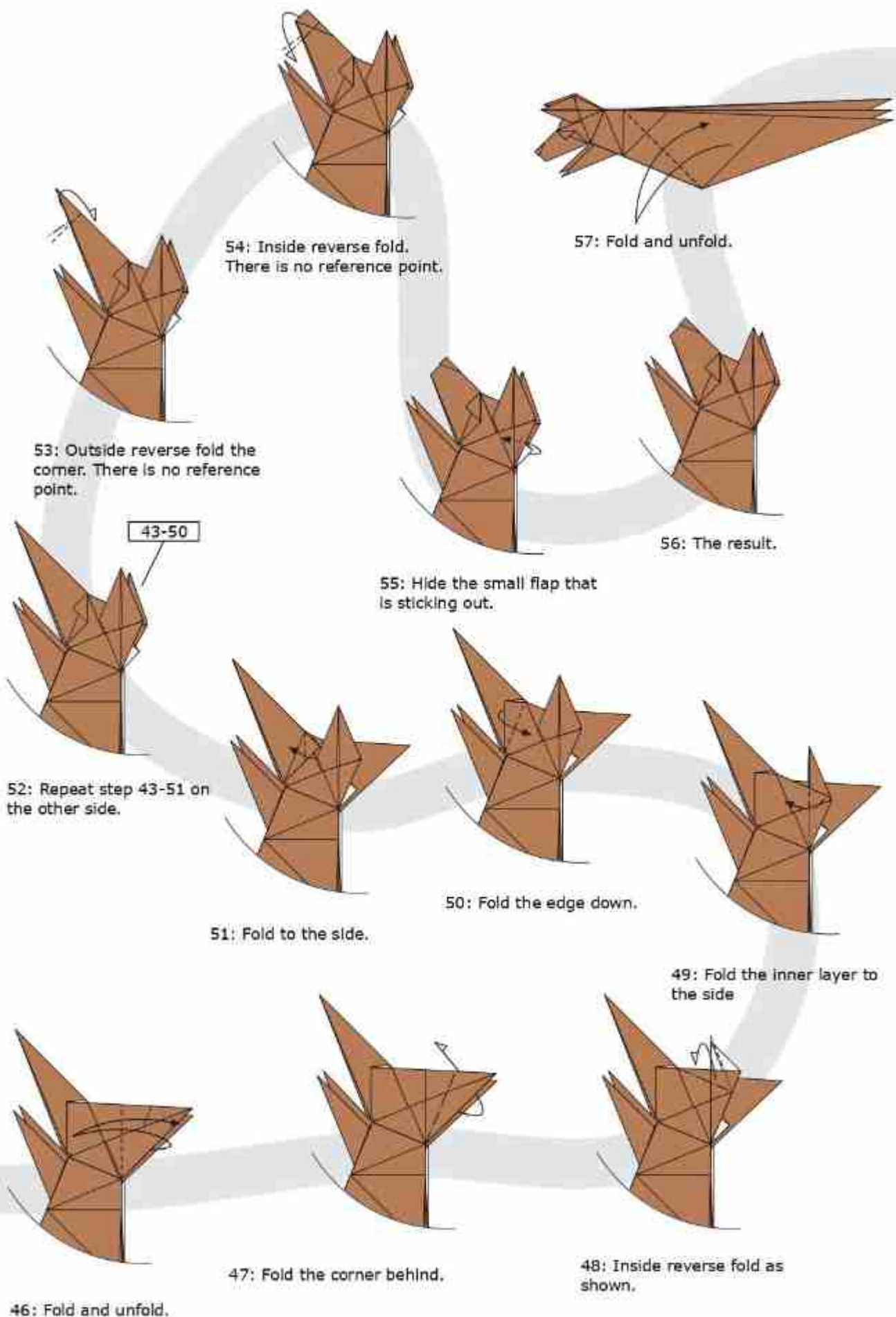

54: Inside reverse fold.
There is no reference point.

57: Fold and unfold.

53: Outside reverse fold the
corner. There is no reference
point.

43-50

56: The result.

55: Hide the small flap that
is sticking out.

52: Repeat step 43-51 on
the other side.

50: Fold the edge down.

51: Fold to the side.

49: Fold the inner layer to
the side

46: Fold and unfold.

47: Fold the corner behind.

48: Inside reverse fold as
shown.



58: Fold an angle bisector and unfold.

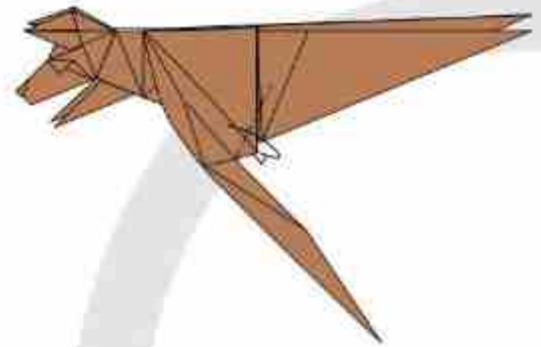

66: Fold the edge behind. There is no reference point.



59: Fold an angle bisector and unfold.

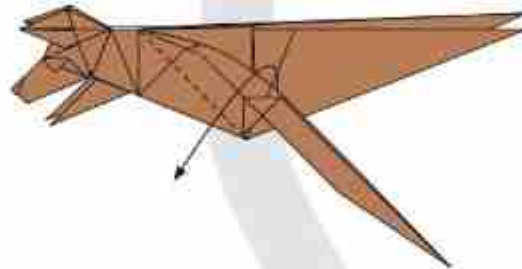

65: Fold the entire flap down.



60: Fold an angle bisector and unfold.

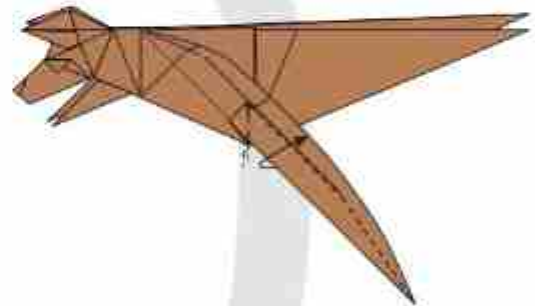

64: Fold up and squash.

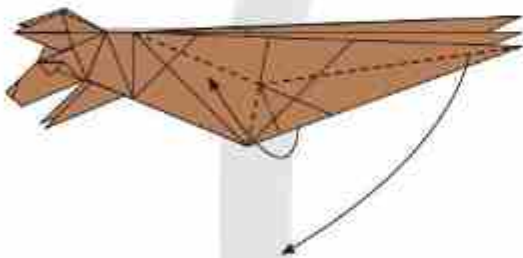

61: Rabbit ear fold.

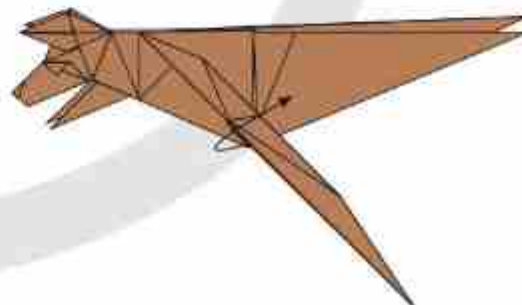

63: Open the flap. The model will not lie flat.

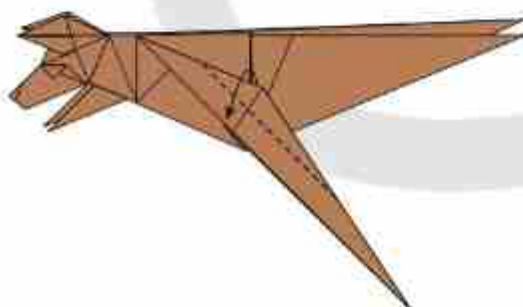

62: Fold the flap in half.

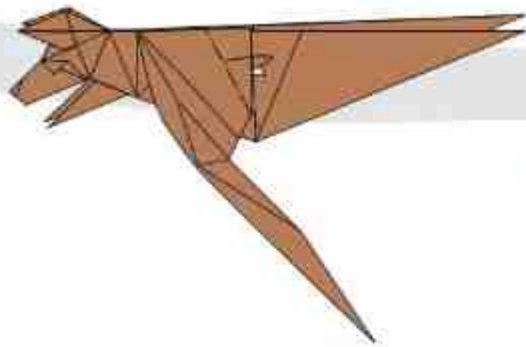

67: Fold the edge behind.
There is no reference point.

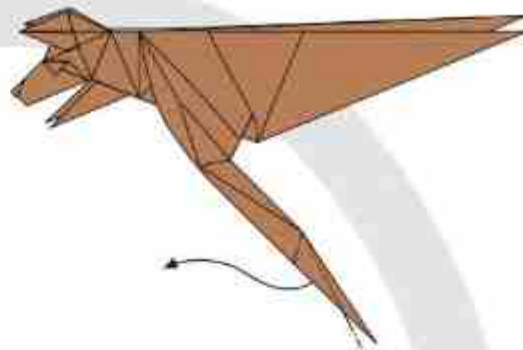

68: Inside reverse fold.

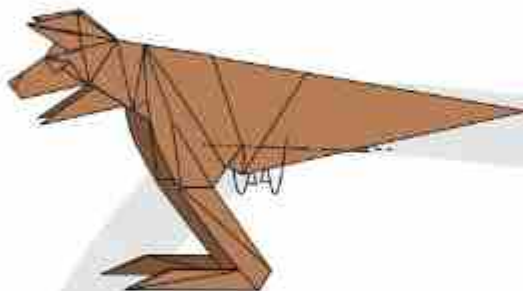

70: Fold the edges inside.



69: Repeat step 57-68 behind.

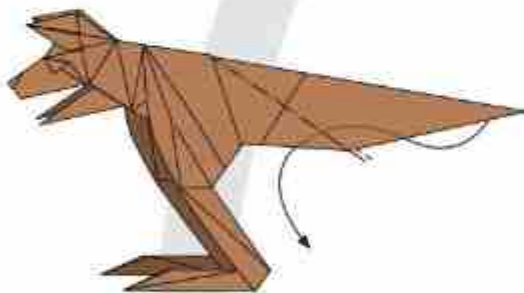

71: Inside reverse fold.



73: Fold the edges inside.



72: Inside reverse fold.



74: squash.

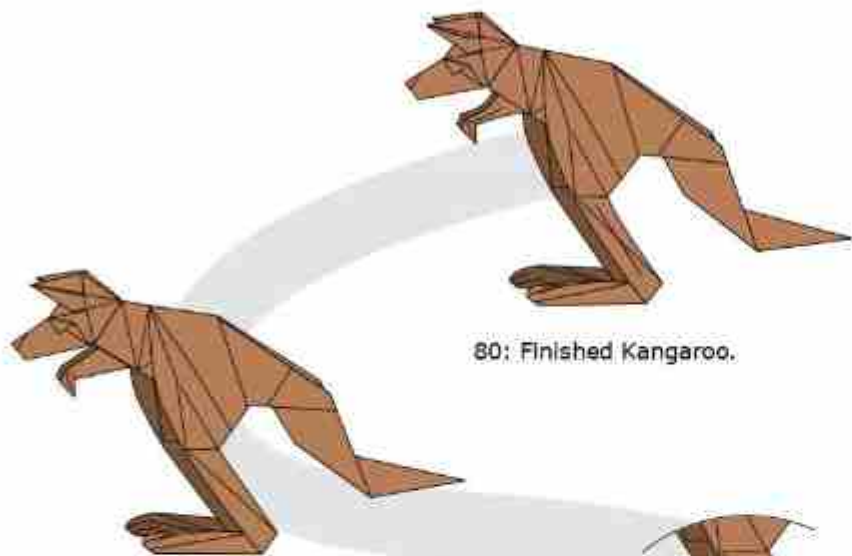

80: Finished Kangaroo.

79: Shape the model.



78: The result.



77: Mountain fold the corners.

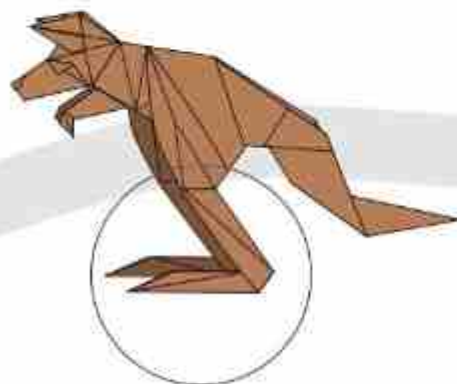

75: The result. Zoom in.



76: Carefully pull the paper apart to give it some volume.

Milk Carton

Bodo Haag

©2023 - Germany

Intermediate

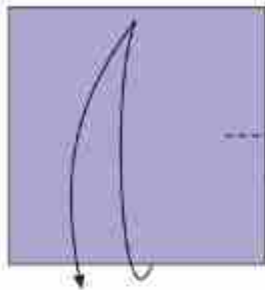

1: Mark the middle of the right edge.

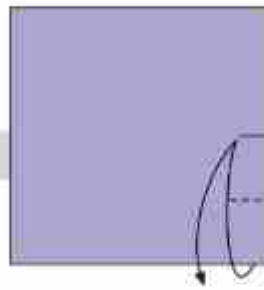

2: Fold the corner to the mark and mark the edge.

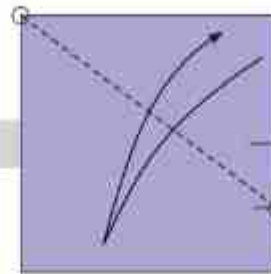

3: Connect the 1/4 mark and the top left corner.

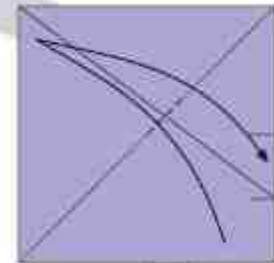

4: Mark the intersection of the diagonal.

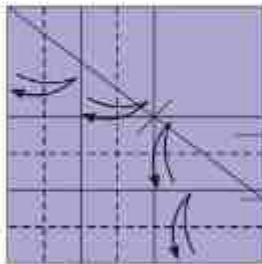

7: Fold the edge to the crease line.

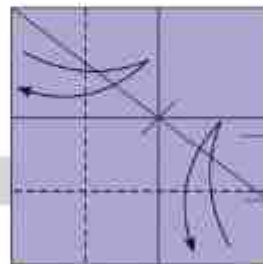

6: Fold the edges to the crease line and unfold.

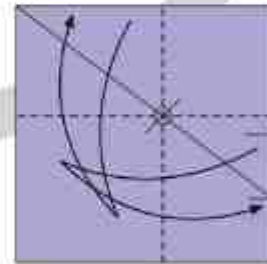

5: Fold through the intersection and unfold.



8: Fold the edges to the crease line and unfold.

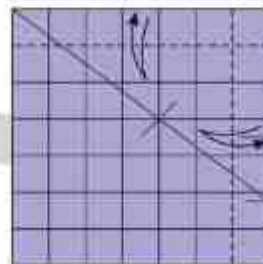

9: Fold the edges to the crease line and unfold.

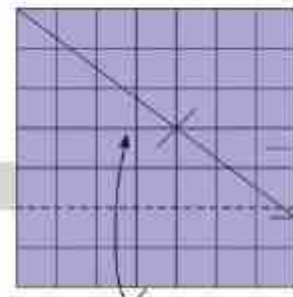

10: Fold the edge up.

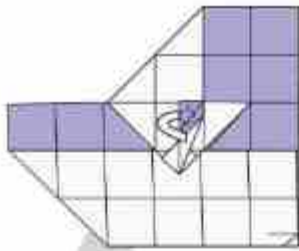

19: Hide the corner inside.

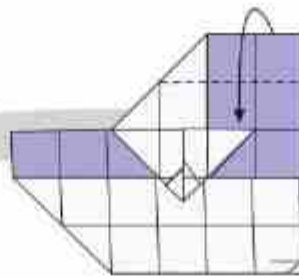

20: Fold the upper edge down.

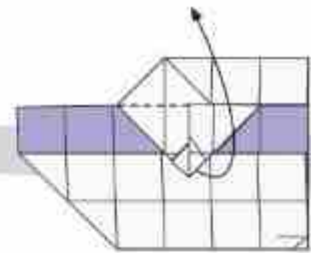

21: Fold the corner up

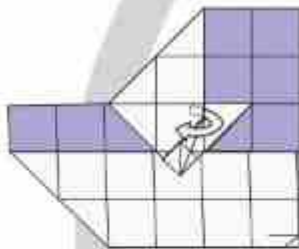

18: Pull out some paper from behind.

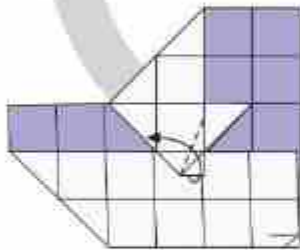

17: Fold the bottom edge to the diagonal.

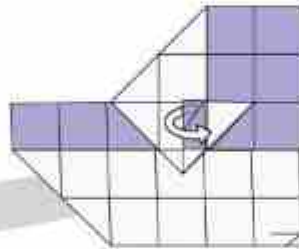

16: Pull out some paper from the inside.

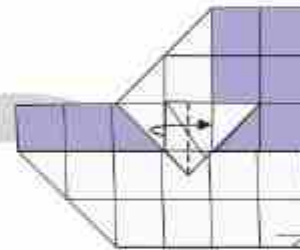

15: Fold the corner over again.

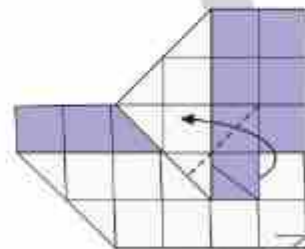

14: Fold the corner over.

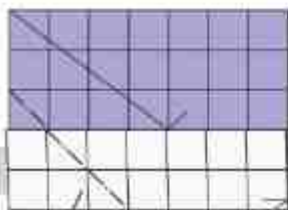

11: Fold the corner behind.

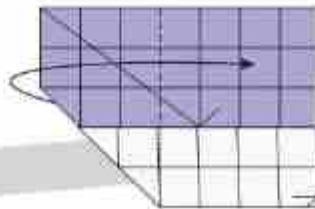

12: Fold the flap to the right. only the inner layer is affected

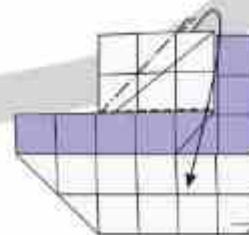

13: Open and squash.

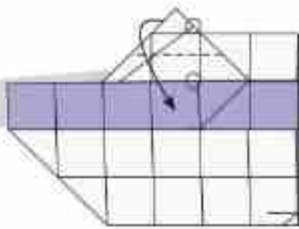

22: Fold the flap down and align the marked point to the edge. look at the next step to see another reference.

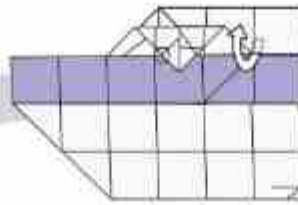

23: Pull out the edge from the bottom.

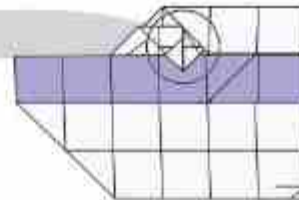

24: Zoom In.

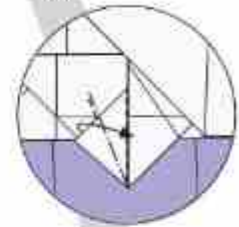

25: Open and squash.

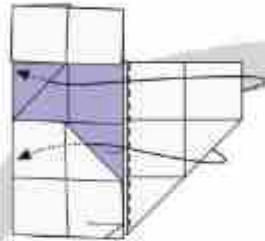

31: Tuck the flap into the pockets.

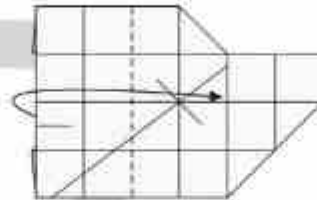

30: Fold the paper over.

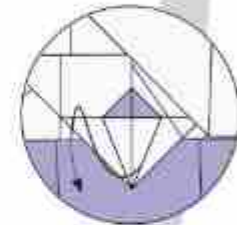

26: Hide the corner inside.

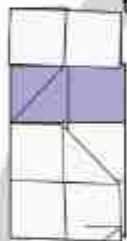

32: The result. Turn over.

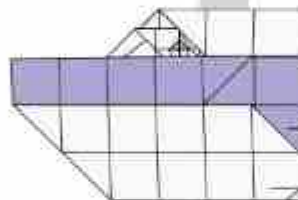

29: The result. Turn over.

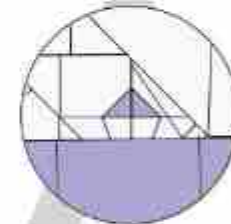

27: The result. Zoom out.

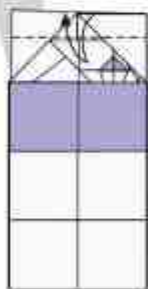

33: Fold and unfold using the edge as a reference

28: Fold the corner behind.

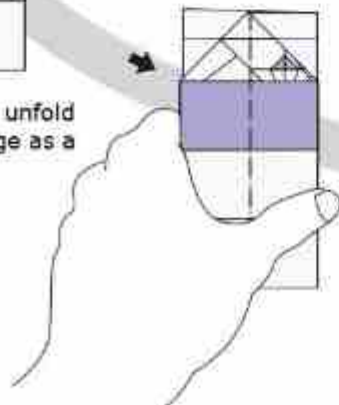

34: Push the paper into a 3D shape.

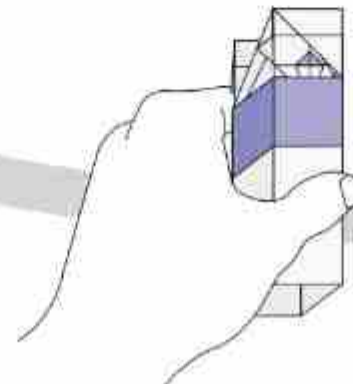

35: Like this. From this point on the model will not lie flat.

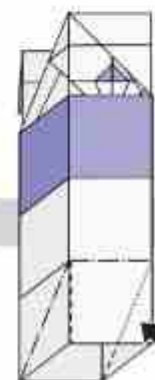

36: Push the edge inside.

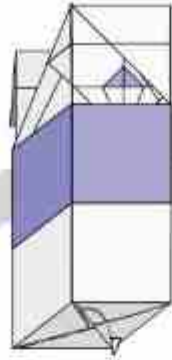

37: Fold the edge inside.

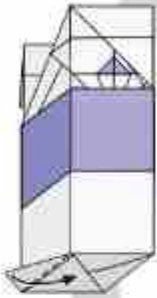

38: Fold the corner to the edge while folding the paper out.

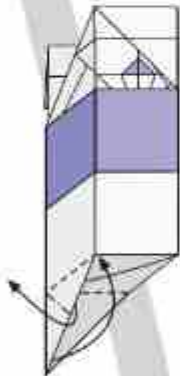

39: Fold the corner to the middle.

38: Fold the corner to the edge while folding the paper out.

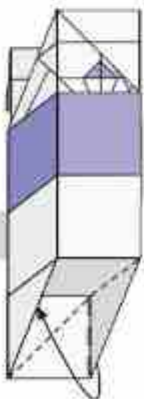

40: Tuck the hidden corner in the pocket.

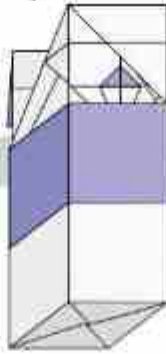

41: The result. View the model from above now.

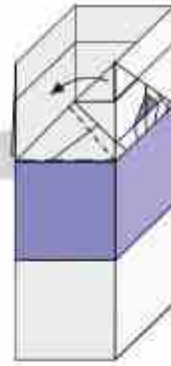

42: Fold the paper in as shown.

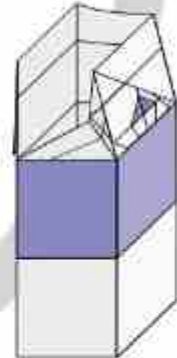

43: The result. Turn over.



44: Bring the two edges together and create new folds.

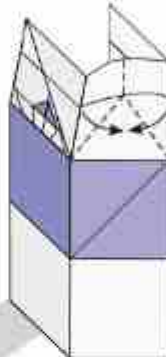

45: Fold the Flap over to lock the model.

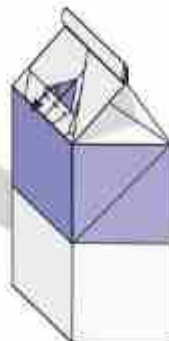

46: Carefully open the paper and give it a round shape.

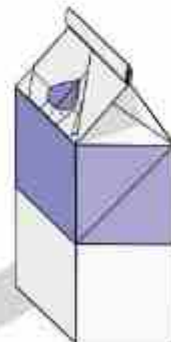

47: Finished Milk.

American Hero

Kyle Harrington

Morgan Lozano (dgrms.)

©2020 - USA

Intermediate

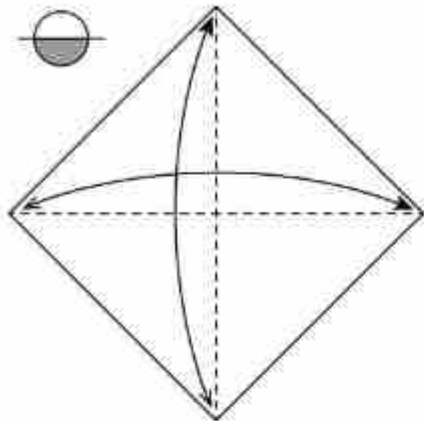

1. Fold and unfold.

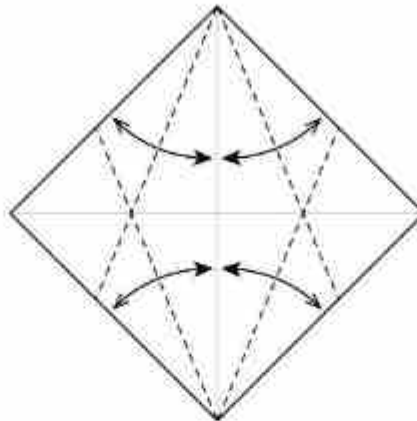

2. Fold and unfold.

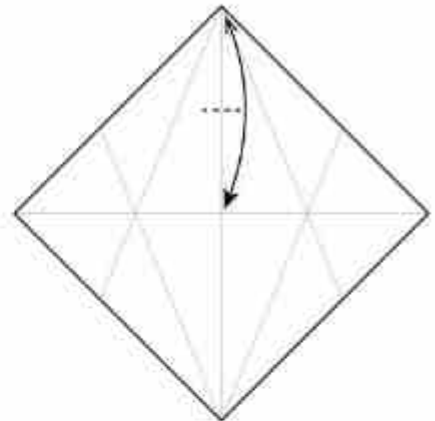

3. Pinch.

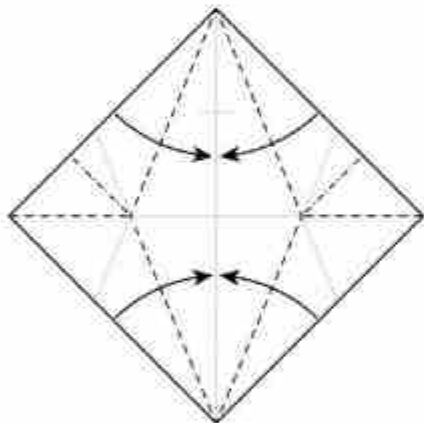

4. Rabbit ear folds.

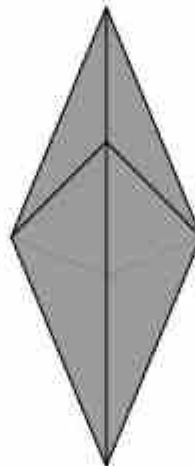

5. Turn over.

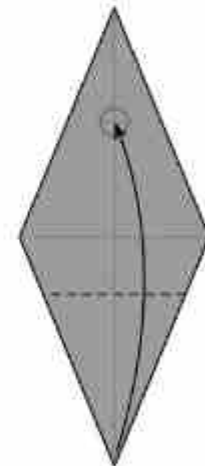

6. Fold to previous crease.

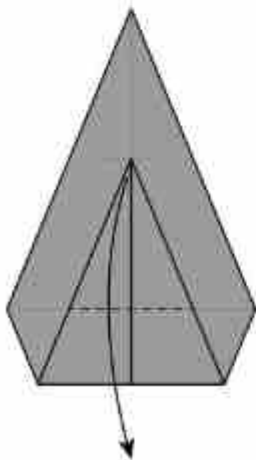

7. Fold down about center line.

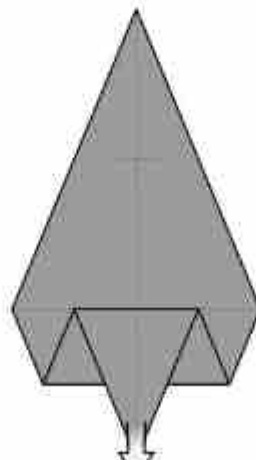

8. Unfold to step 6.

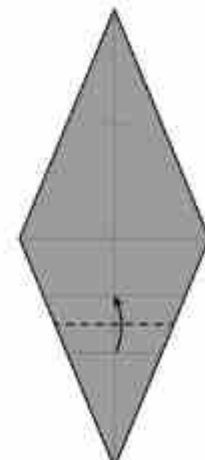

9. Pleat fold.

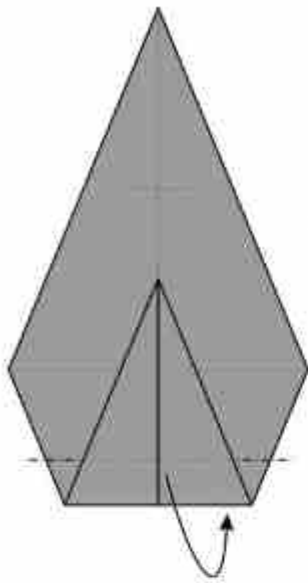

10. Mountain fold only the back layer.

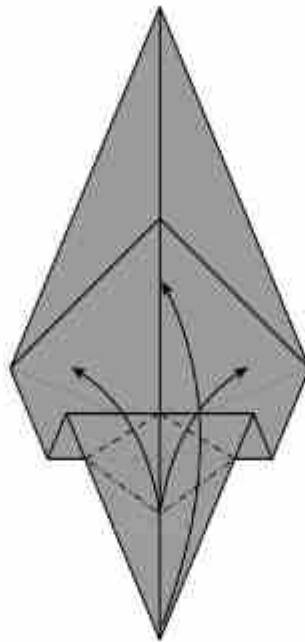

11. Open the layers in the middle and fold up as shown.

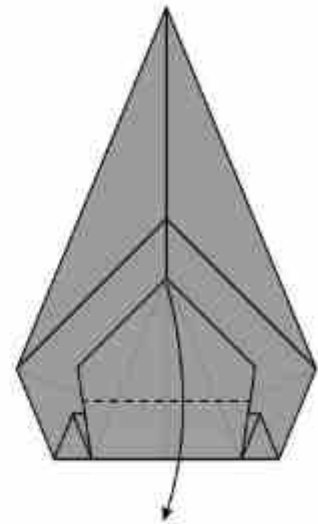

12. Fold as a shown (without references).

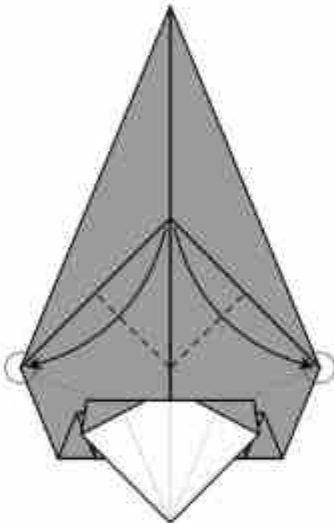

13. Fold the tips to the corners.

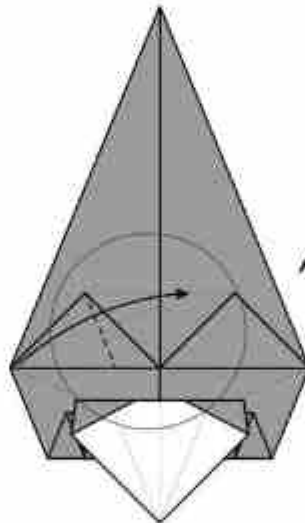

14. Valley fold Keeping the edges parallel.

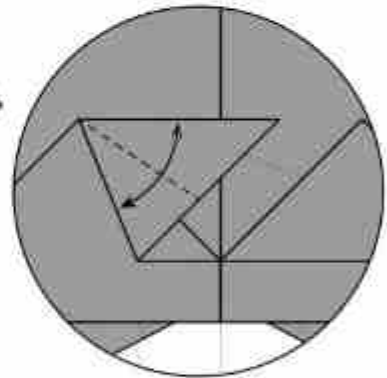

15. Fold edge to edge and unfold.

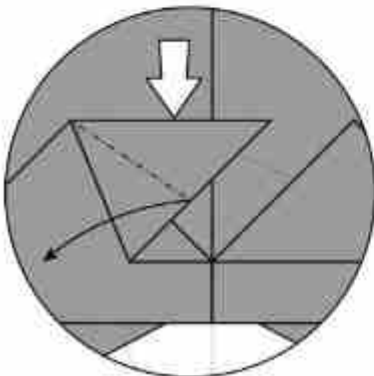

16. Squah fold.

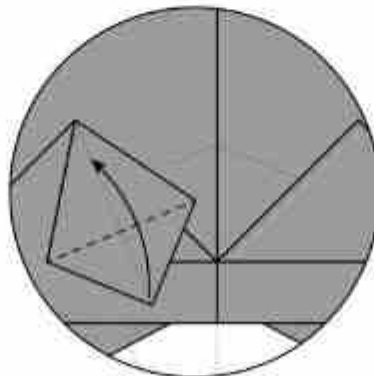

17. Valley fold.

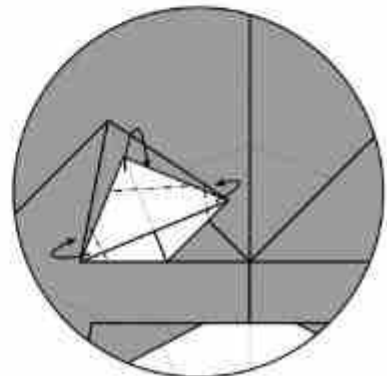

18. Mountain folds for finish the eye.

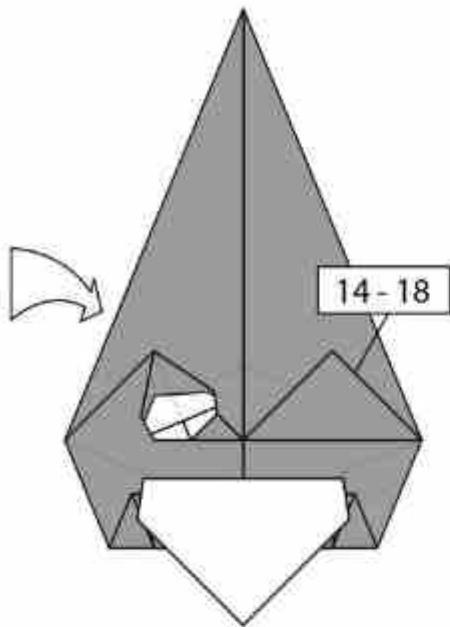

19. Repeat on the right side.

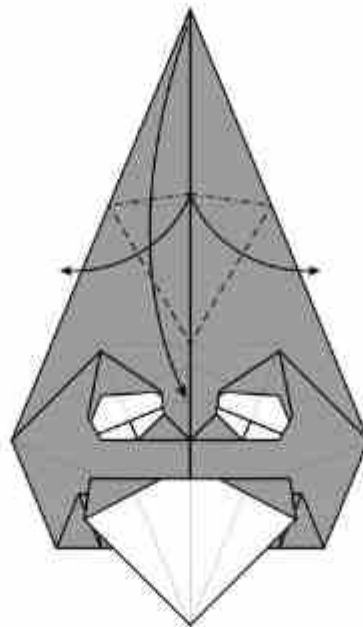

20. Fold as shown approximately. Use dotted lines near eyes as a reference.

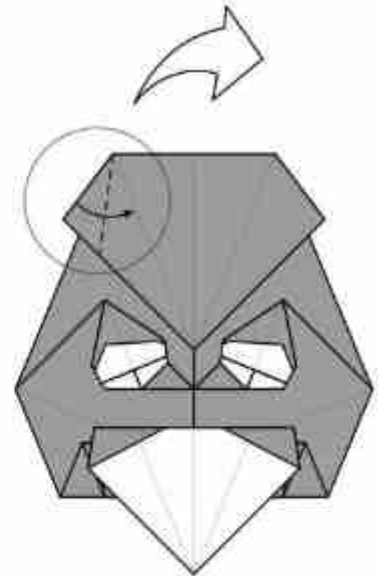

21. Fold the bisector.

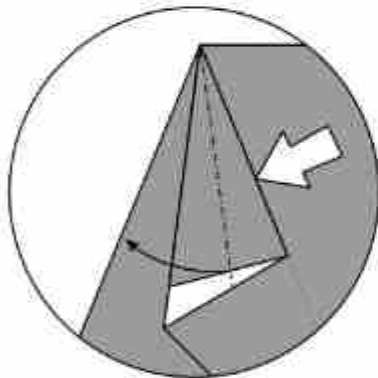

22. Squash fold.

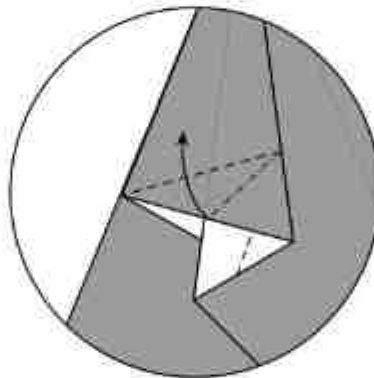

23. Swivel fold.

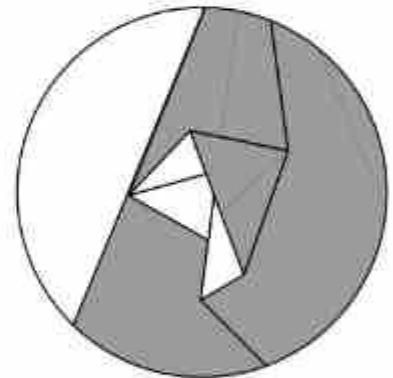

24. Zoom out.

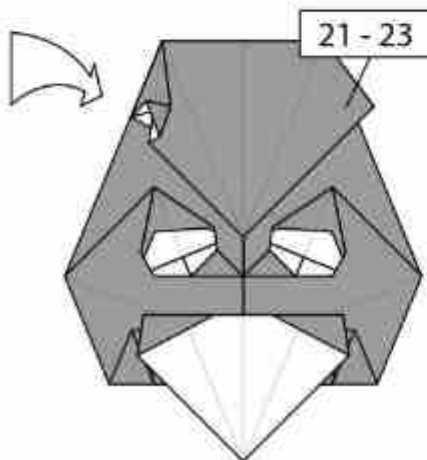

25. Repeat on the right side.

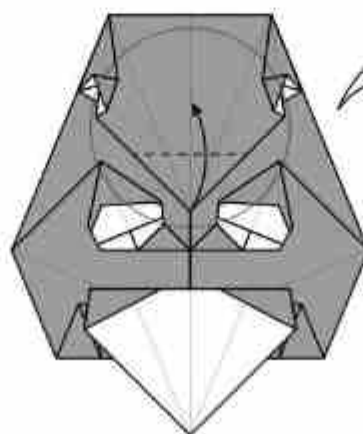

26. Fold aligning with the back layers.

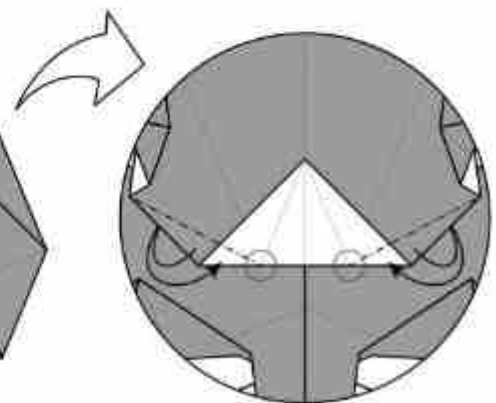

27. Fold and unfold the corners.

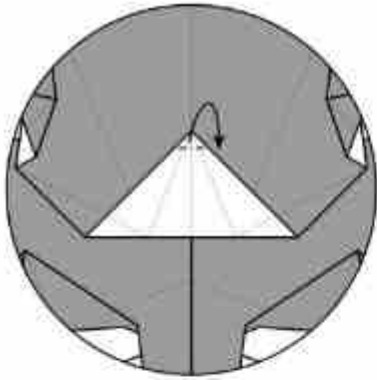

28. Fold the tip just a little.

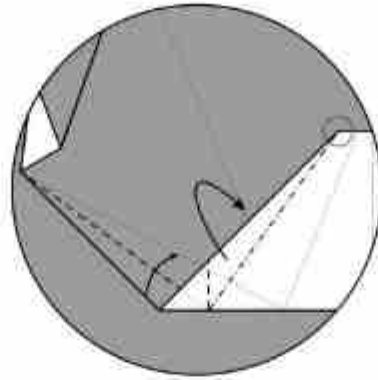

29. Swivel fold to back. Repeat on the right side.

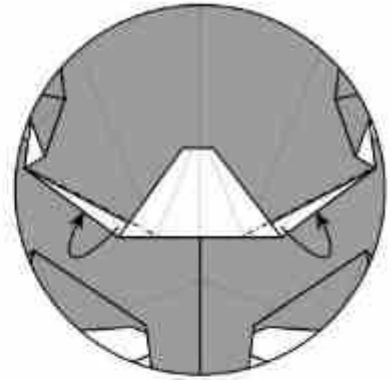

30. Fold using previous creases.

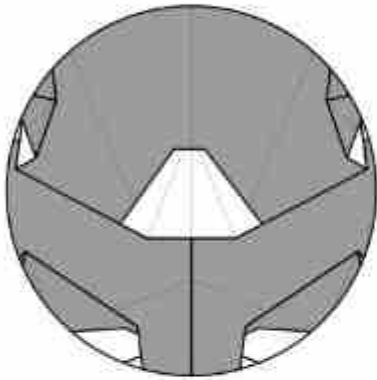

31. Fold using previous creases.

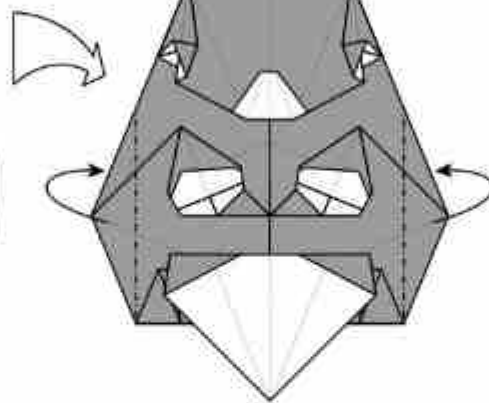

32. Mountain folds.

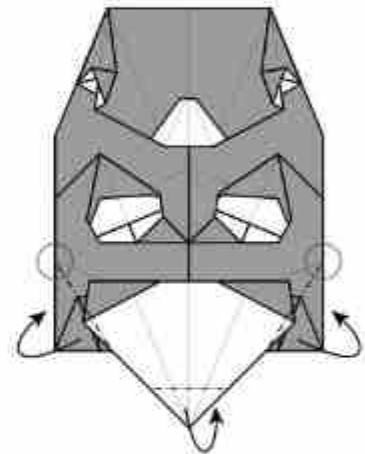

33. Shape the face down.

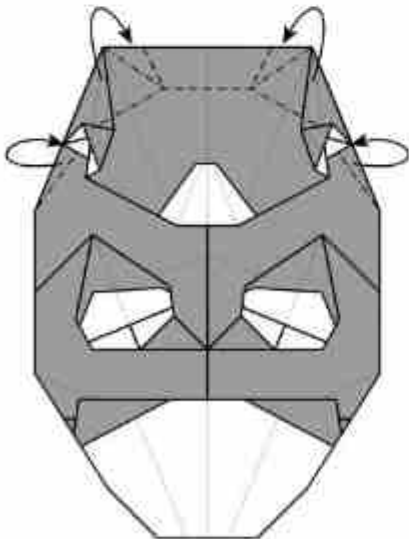

34. Shape the head to finish.

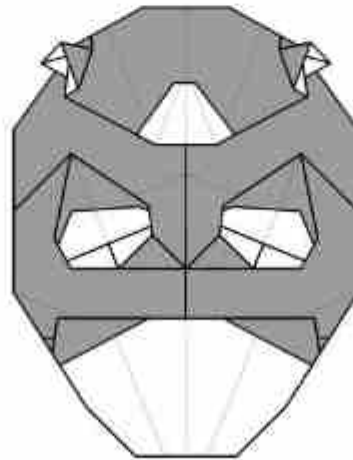

35. Model Completed.

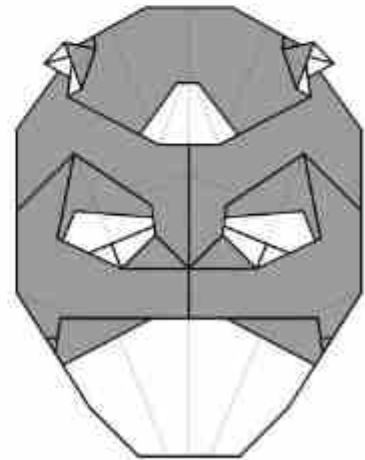

Eyes Variation.

Stuffed Penguin

Hashimoto Haruka

©2022 - Japan

High Intermediate

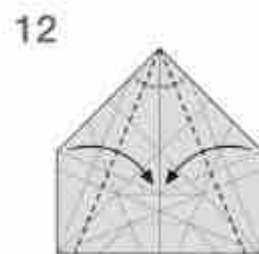
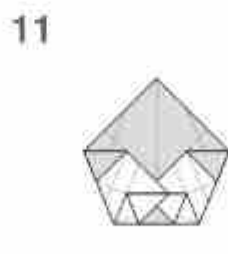
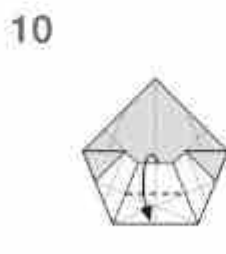
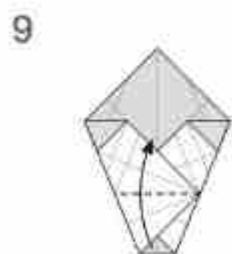
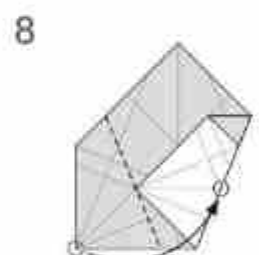
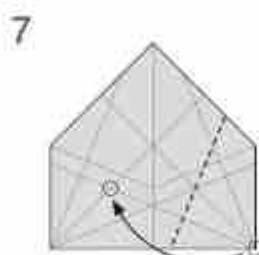
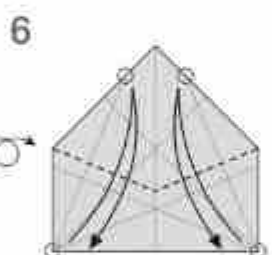
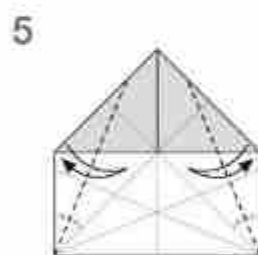
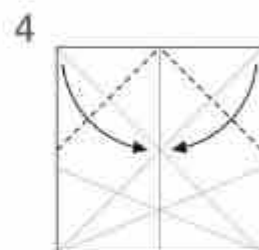
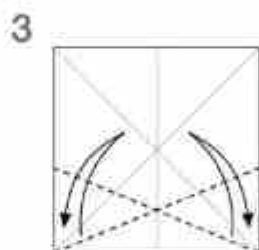
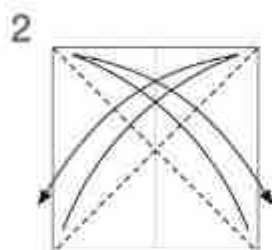
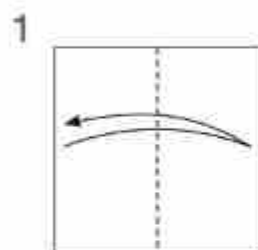
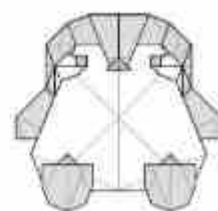
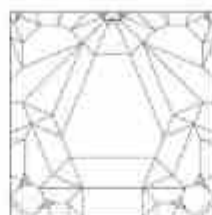

Unfold to 7.

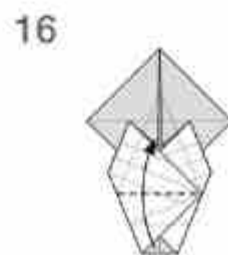
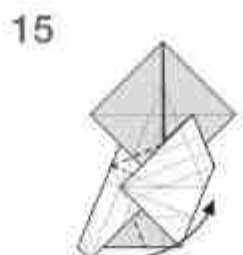
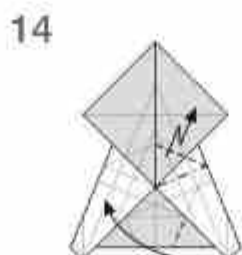
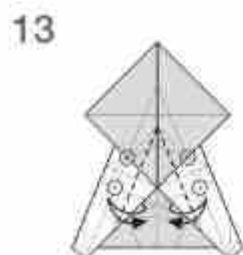

17

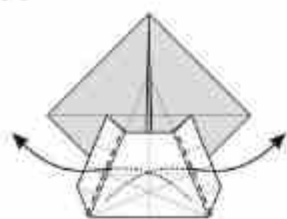

18

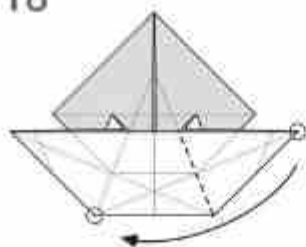

19

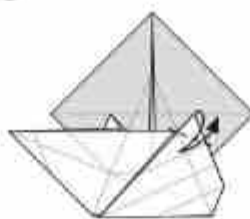

20

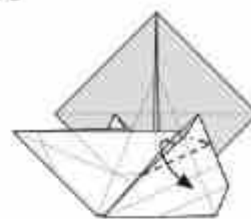

21

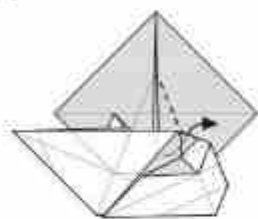

22

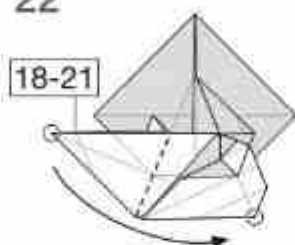

Repeat steps 18-21.

23

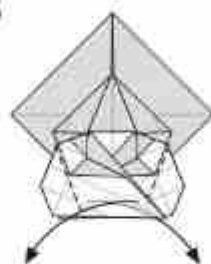

24

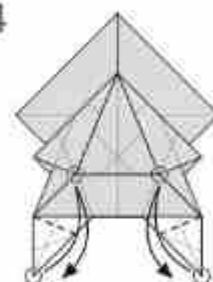

25

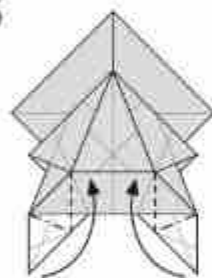

26

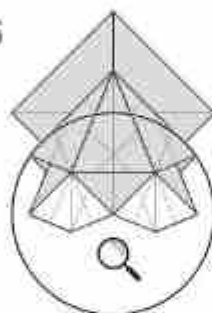

27

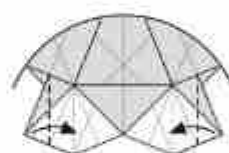

28

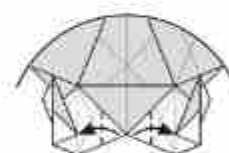

29

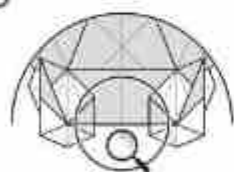

30

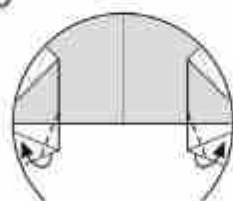

31

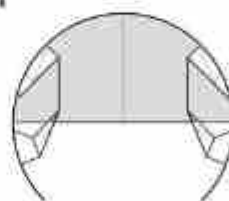

32

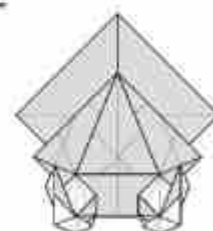

Unfold to 26.

33

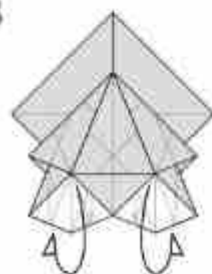

34

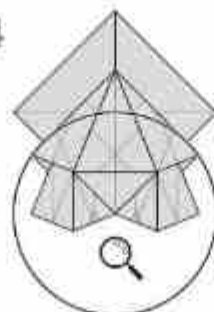

35



36



37



38



39

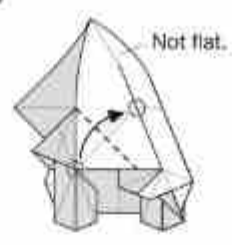

40

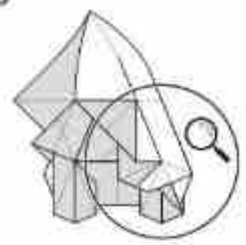

41



42

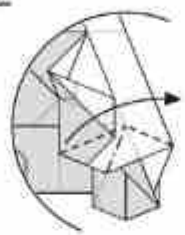

43

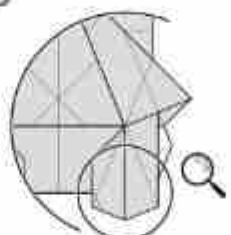

44



Open-sink.

45

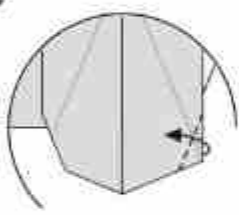

46

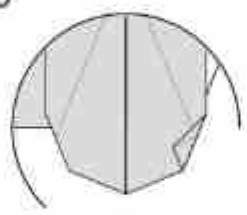

47

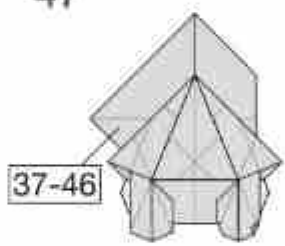

48

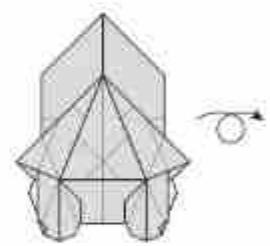

Repeat steps 37-46.

49

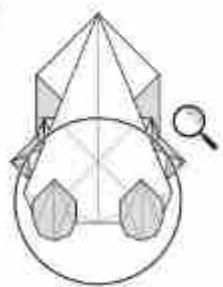

50



51



52

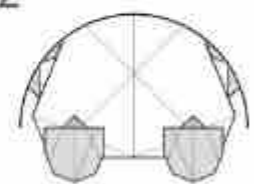

53

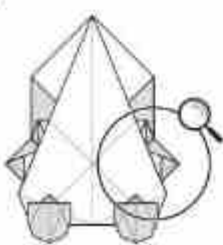

54



55

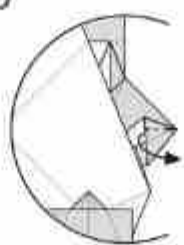

56

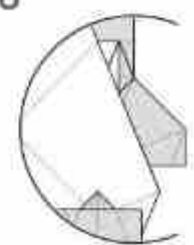

57

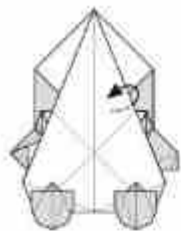

58

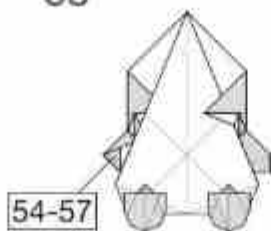

59

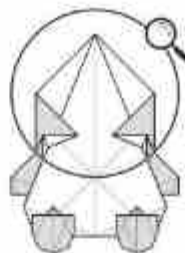

60

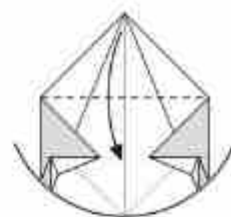

Repeat steps 54-57.

61

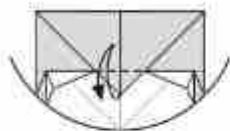

62

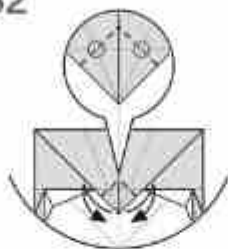

63

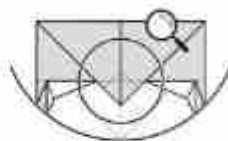

64

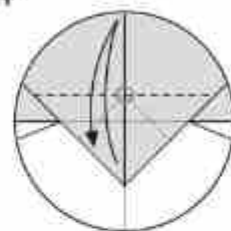

65

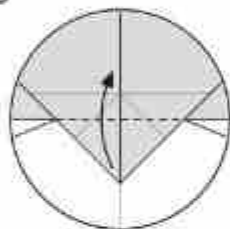

66

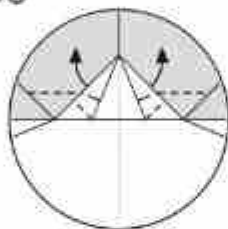

67

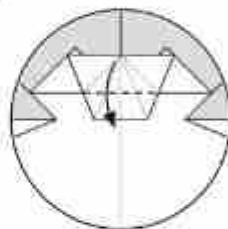

68

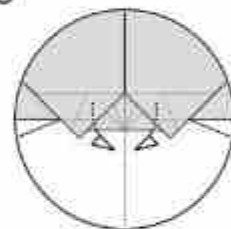

69

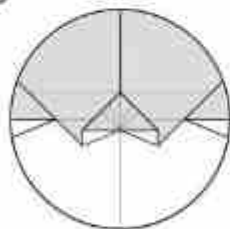

70

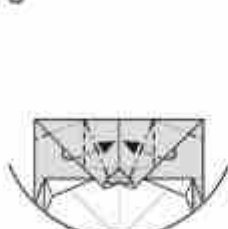

71

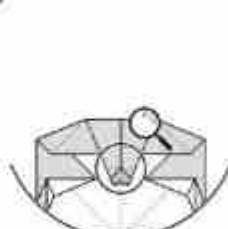

72

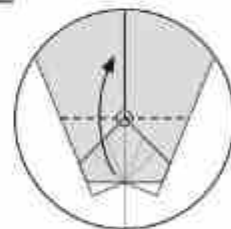

73

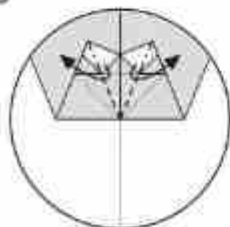

74

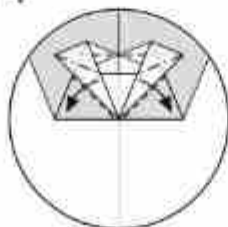

75

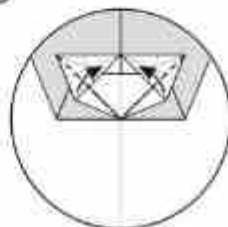

76

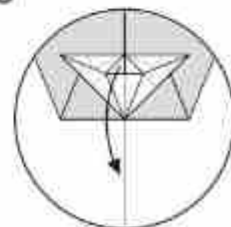

77

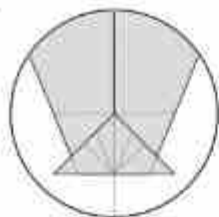

78

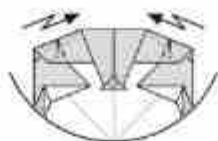

79

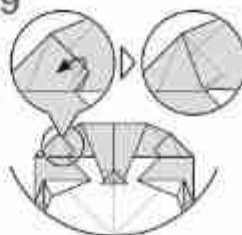

80

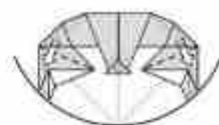

81

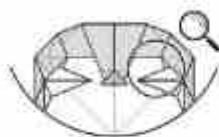

82

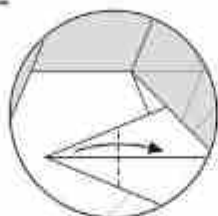

83

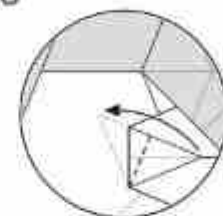

84

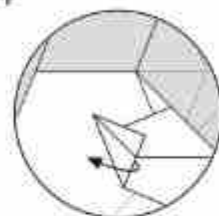

85

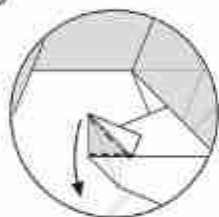

86

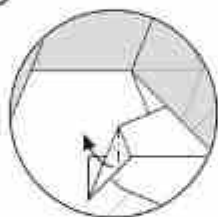

87

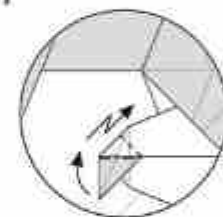

88

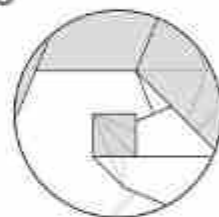

89



82-88

Repeat steps 82-88.

90

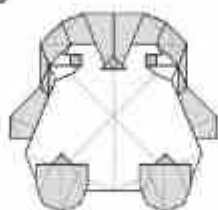

Finished.

Peace and Love

Xiaoxian Huang

©2022 - China

Complex



设计：2022年9月
绘图：2022年11月

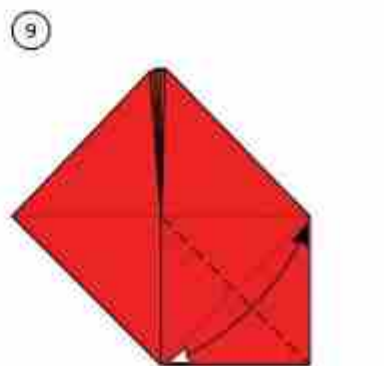
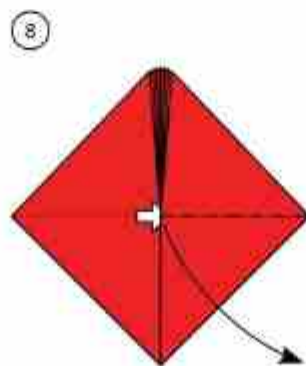
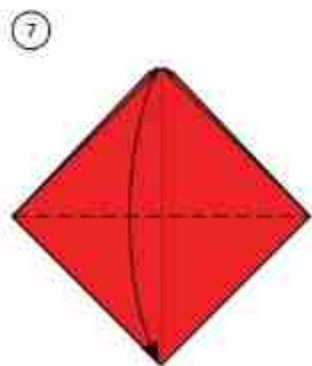
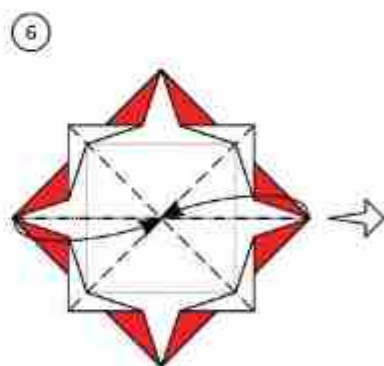
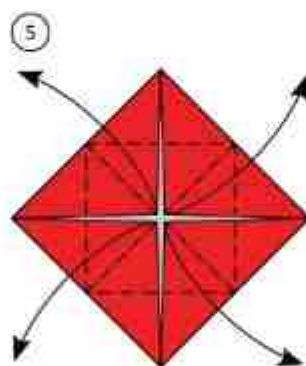
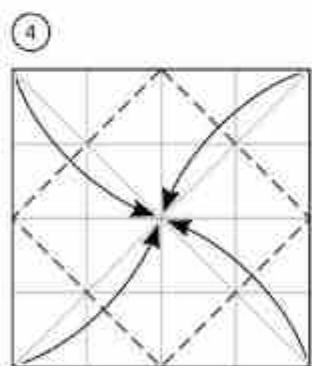
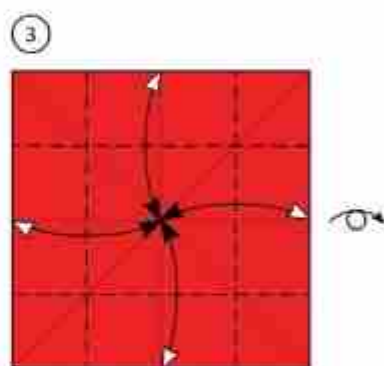
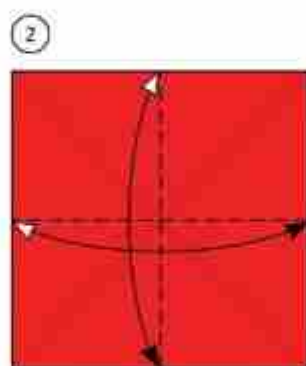
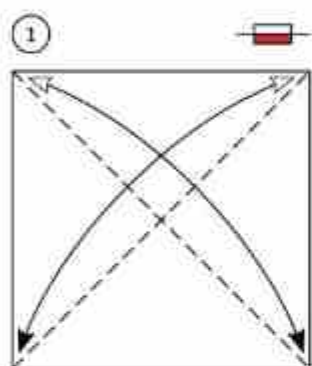
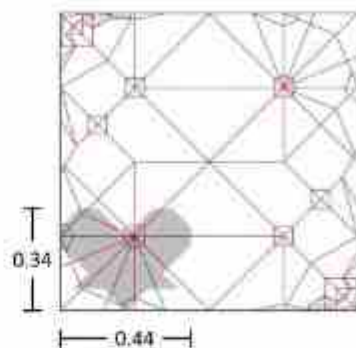

10

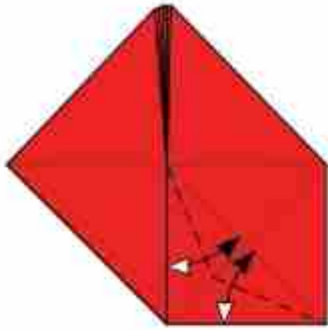

11

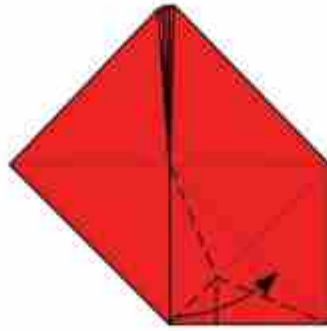

12

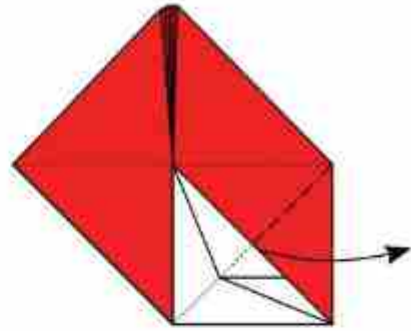

13

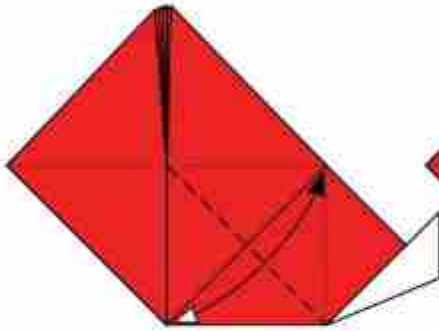

14

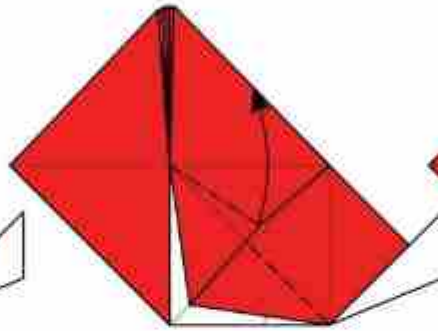

15

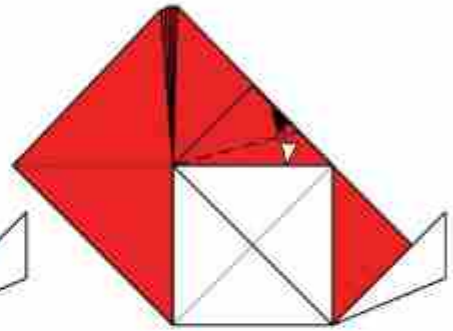

16

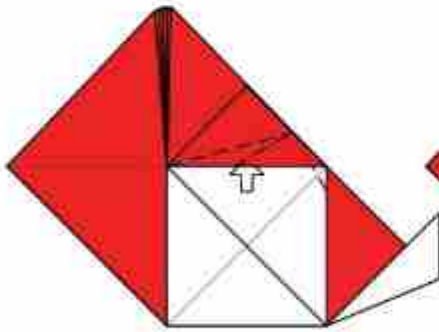

17

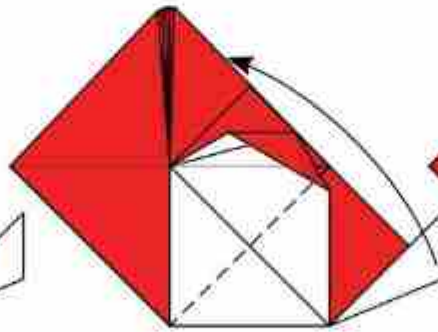

18

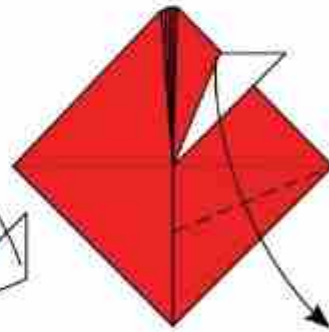

19

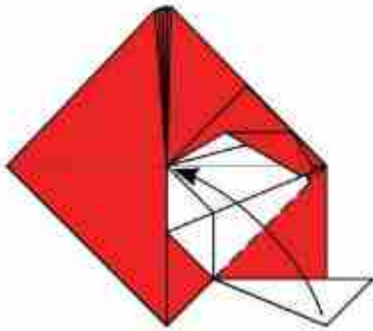

20

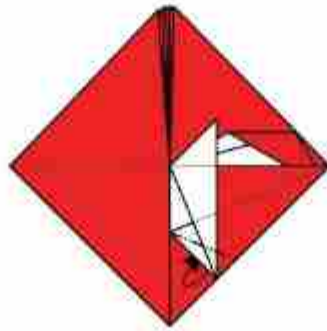

21

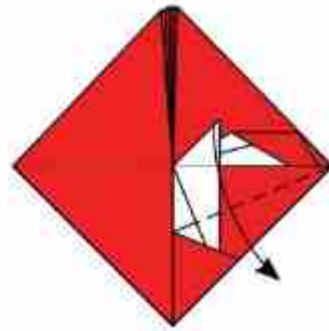

22

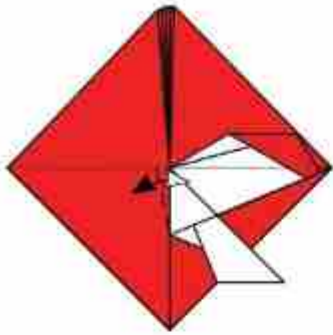

23

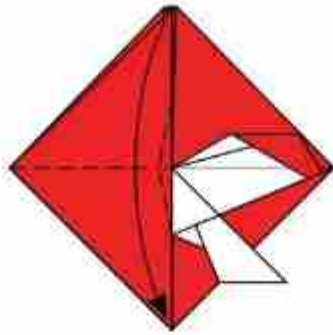

24

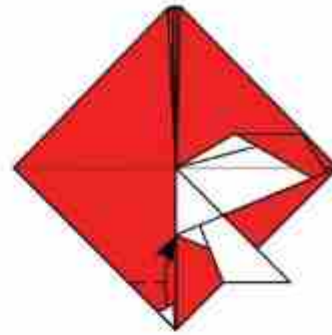

25

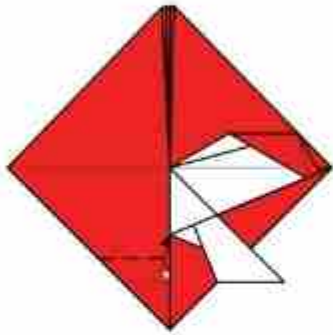

26

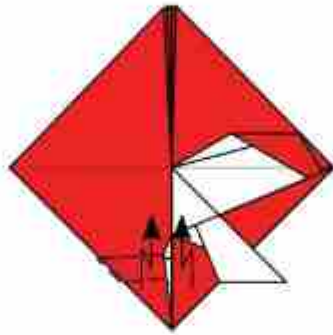

27

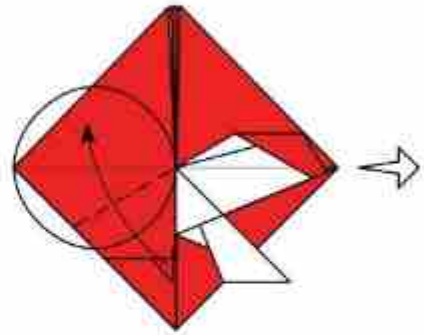

28



29

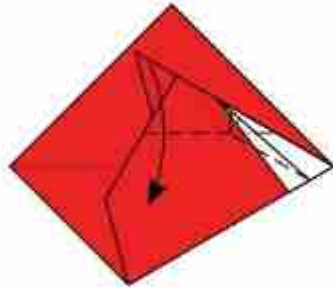

30



31

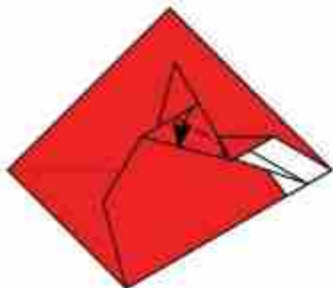

32

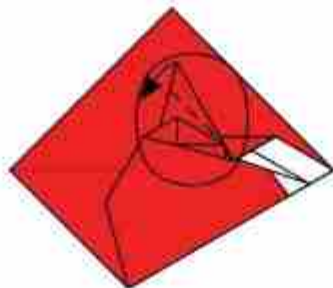

33

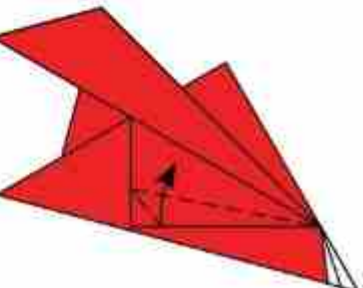

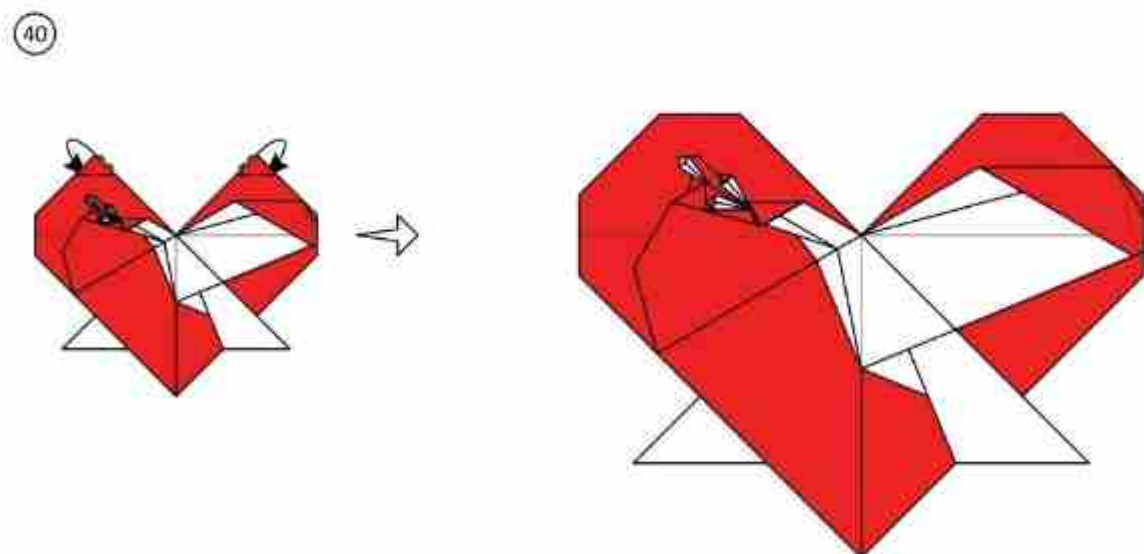
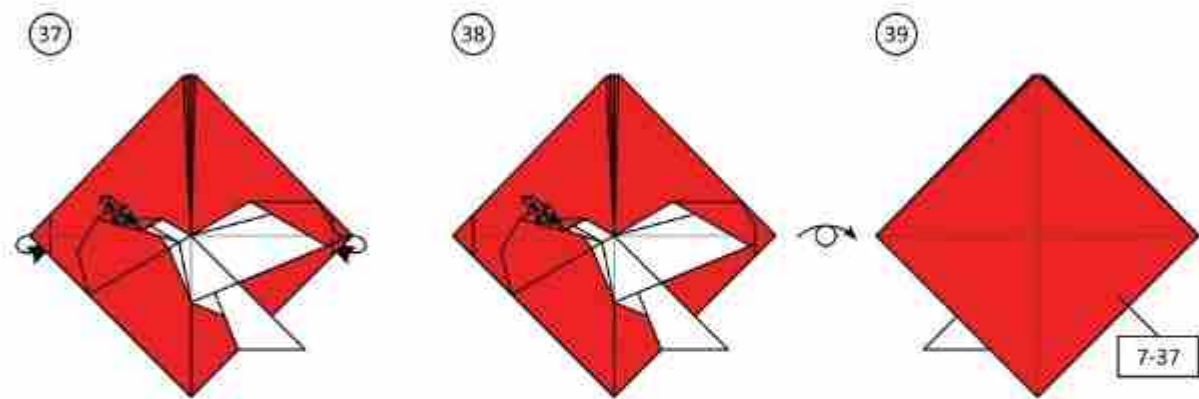
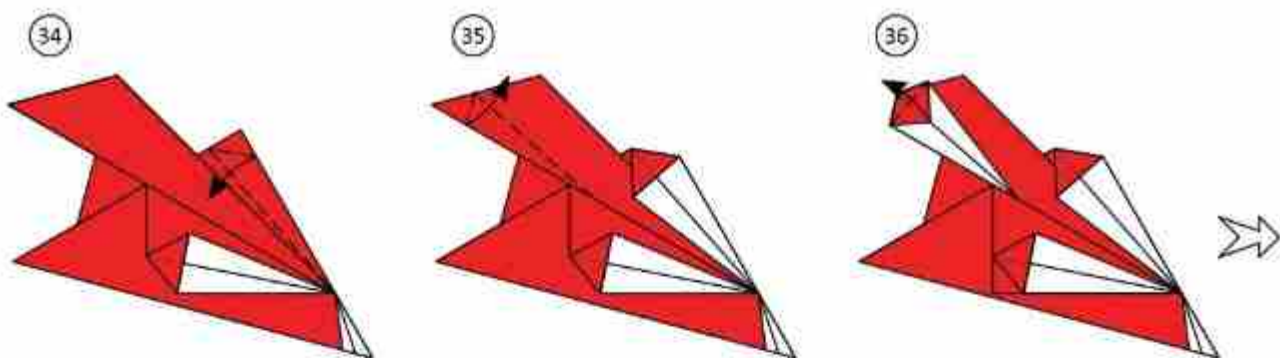

Mushroom Bookmark

Andrew Hudson

©2023 - USA

Intermediate

Recommended paper size:
15 cm (6 in)

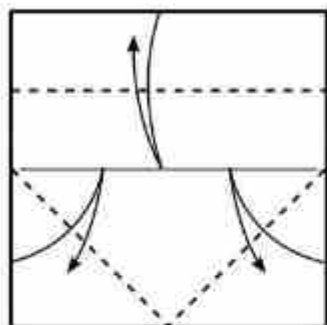

1. Precrease.

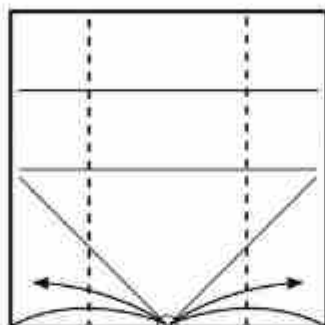

2. Precrease, then
turn over.

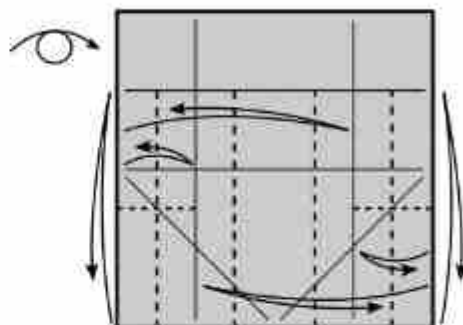

3. Precrease.

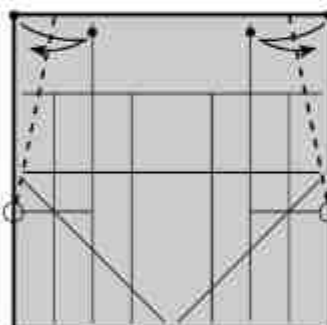

4. Precrease, then
turn over.

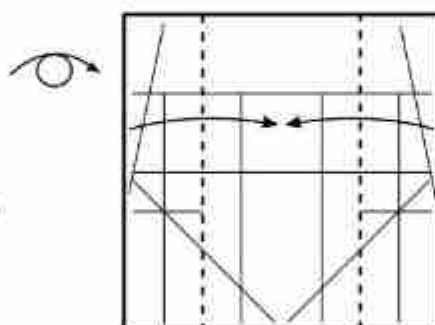

5. Fold on existing
creases.

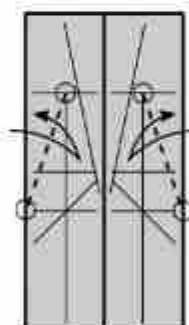

6. Precrease, then
unfold.

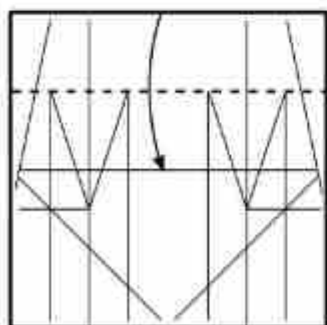

7. Fold on an
existing crease.

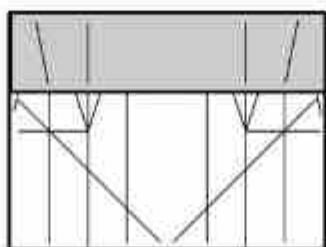

8. Turn over.

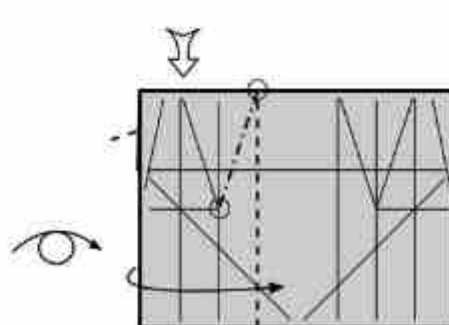

9. Swivel the top
layer. Don't flatten
the bottom edge.

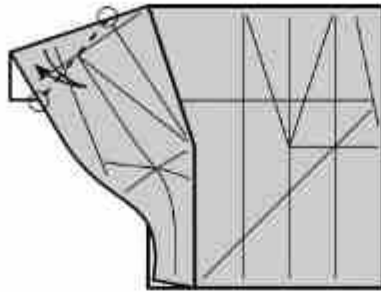

10. Precrease through both layers.

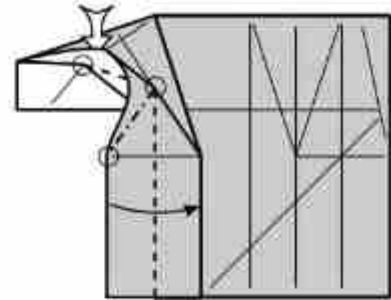

11. Swivel the top layer...

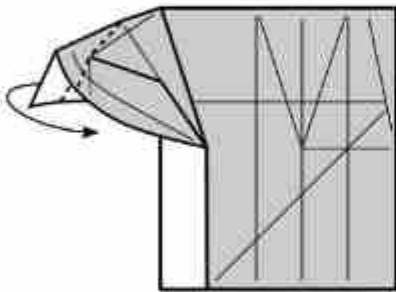

12. ...and flatten along the existing crease.

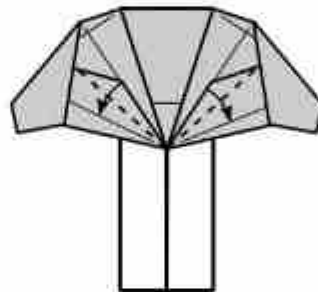

13. Bisect the angle on the middle flap.

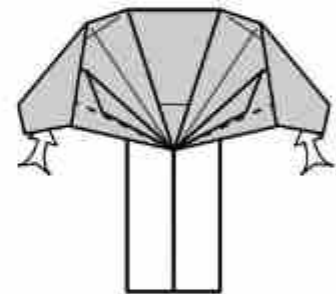

14. Reverse-fold using an existing crease.

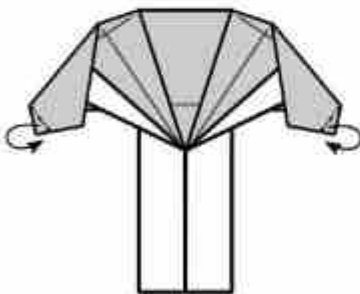

15. Narrow the corners.

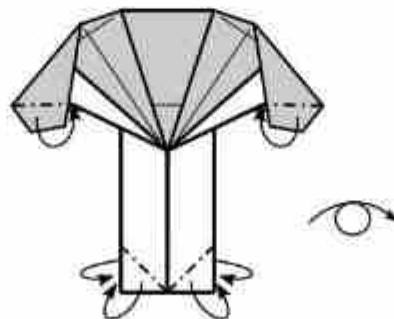

16. Tuck into pockets, then turn over.

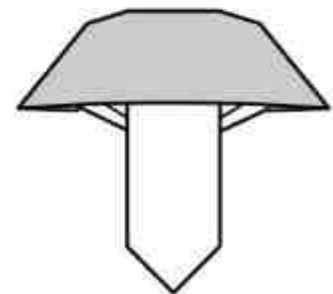

Finished!

Circle Braid

Miyuki Kawamura

©20223 - Japan

Intermediate

図を拡大
Enlarge diagrams

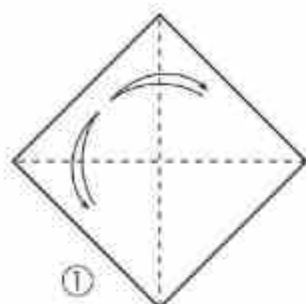

①

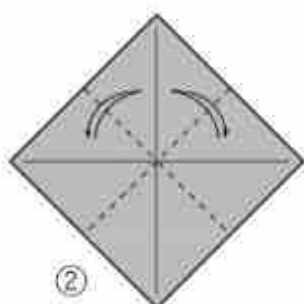

②

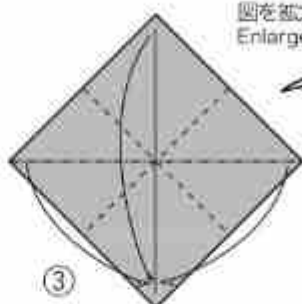

③

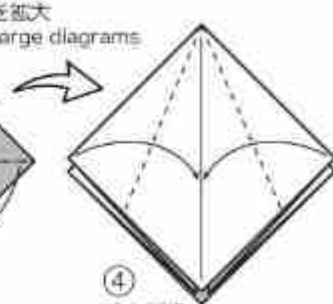

④

裏も同様。
Do the same on
the back side.

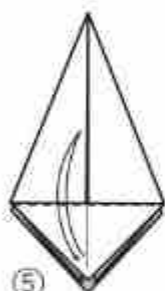

⑤

折り目をつける。
他の3箇所も同様。
Fold and unfold.
Do the same on the
other three corners.

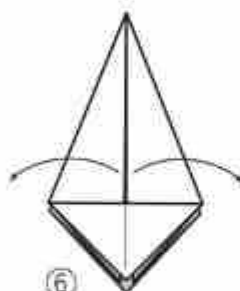

⑥

開く。裏も同様。
Unfold. Do the same
on the back side.

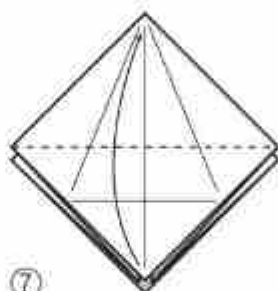

⑦

1枚だけ折る。他の3箇所も同様。
Fold one layer up. Do the same
on the other three corners.

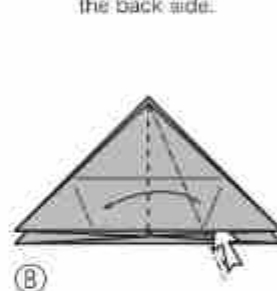

⑧

開いてつぶす。
Open the pocket and squash.

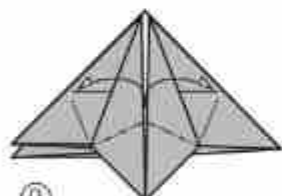

⑨

開いてつぶす。
Open the pocket and squash.

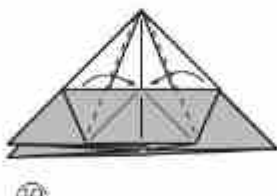

⑩



⑪

他の3箇所も同様。
Do the same on the other
three corners.



⑫

開く
Unfold.

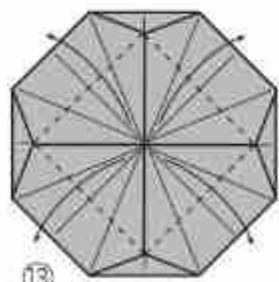

⑬

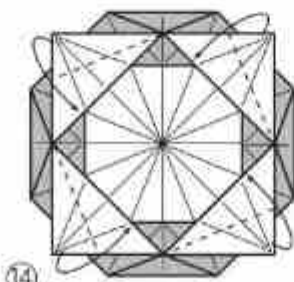

⑭

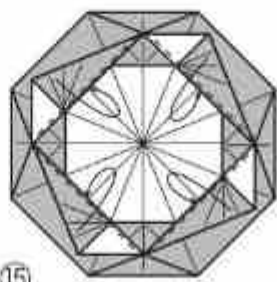

⑮

カドをポケットの中に折り込む。
Tuck the four flaps inside.

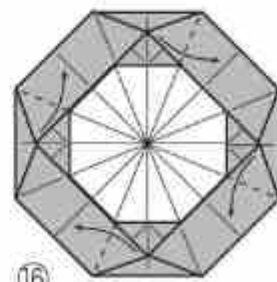

⑯

4つのカドを折り返す。
Fold the four flaps.

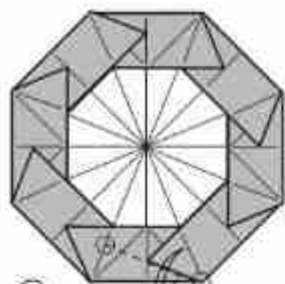

①⑦
カドのフチに沿って折り目をつける。他の7ヶ所も同様に折る。
Fold along edge of the flap and unfold. Do the same on the all flaps.

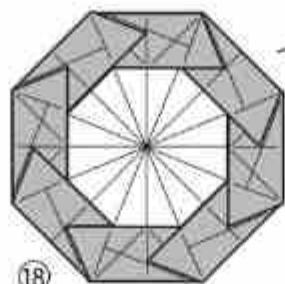

①⑧

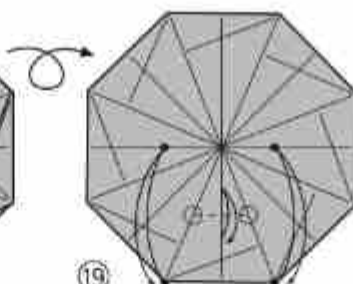

①⑨

外側のフチを中心線に合わせて折り目をつける。他の7ヶ所も同様に折る。
Fold the bottom edge up to the horizontal center line and unfold. Do the same on the all edges.

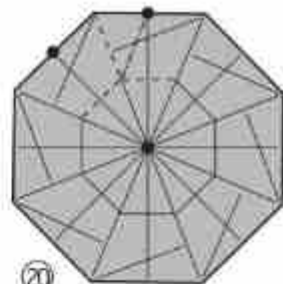

①⑩

図のとおり折り目をつける。他の7ヶ所も同様に折る。
Make crease as shown. Do the same on the all areas.

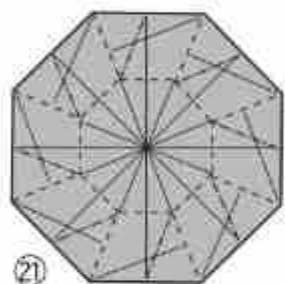

①⑪
図のとおり折りたたむ。
Fold as shown.

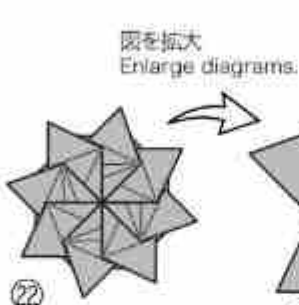

①⑫

図を拡大
Enlarge diagrams.

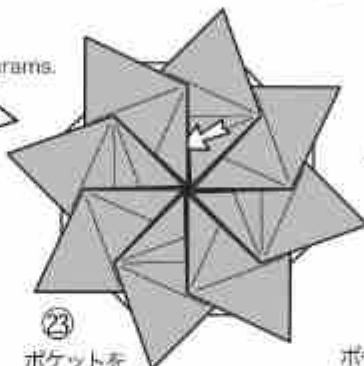

①⑬
ポケットを少し開く。
Open the pocket a little.

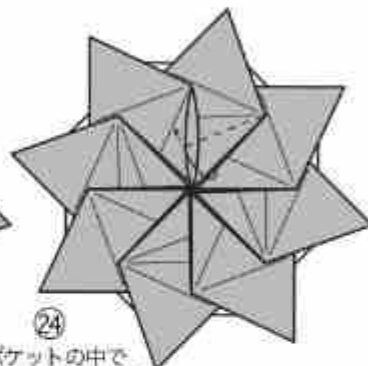

①⑭
ポケットの中でカドを折り上げる。中割り折りではありません。
Fold the corner up inside the pocket. It is not a inside reverse fold.



①⑮
他の7カ所も同様に折る。
Fold the other 7 corners in the same way.

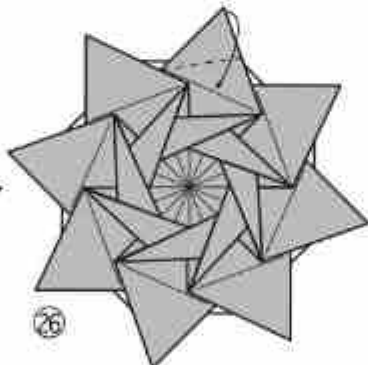

①⑯

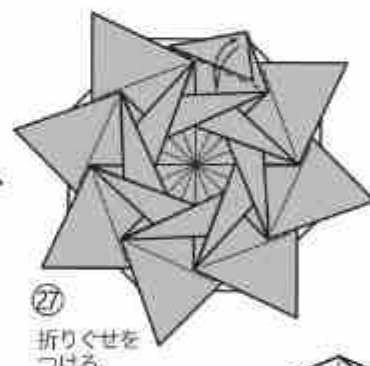

①⑰
折りくせをつける。
Fold and unfold.



①⑱
ポケットの中に入れる。
Tuck the corner inside the pocket.

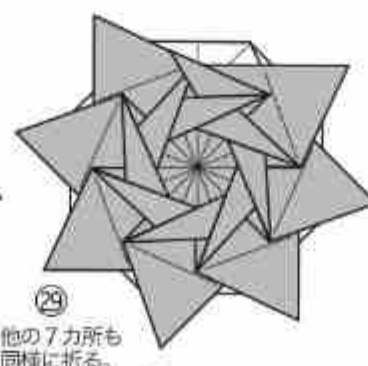

①㉑

他の7カ所も同様に折る。
Fold the other 7 corners in the same way.

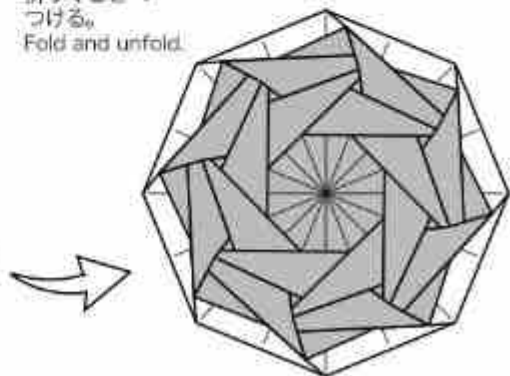

サークル・ブレイド/Circle Braid

©2023 川村みゆき/KAWAMURA Miyuki
創作日/Creation Date: Jan. 26, 2023

House

Intermediate

Miyuki Kawamura

©2019 - Japan

- Use two sheets of square paper of the same size.
同じ大きさの正方形用紙を2枚使います。

Walls/壁

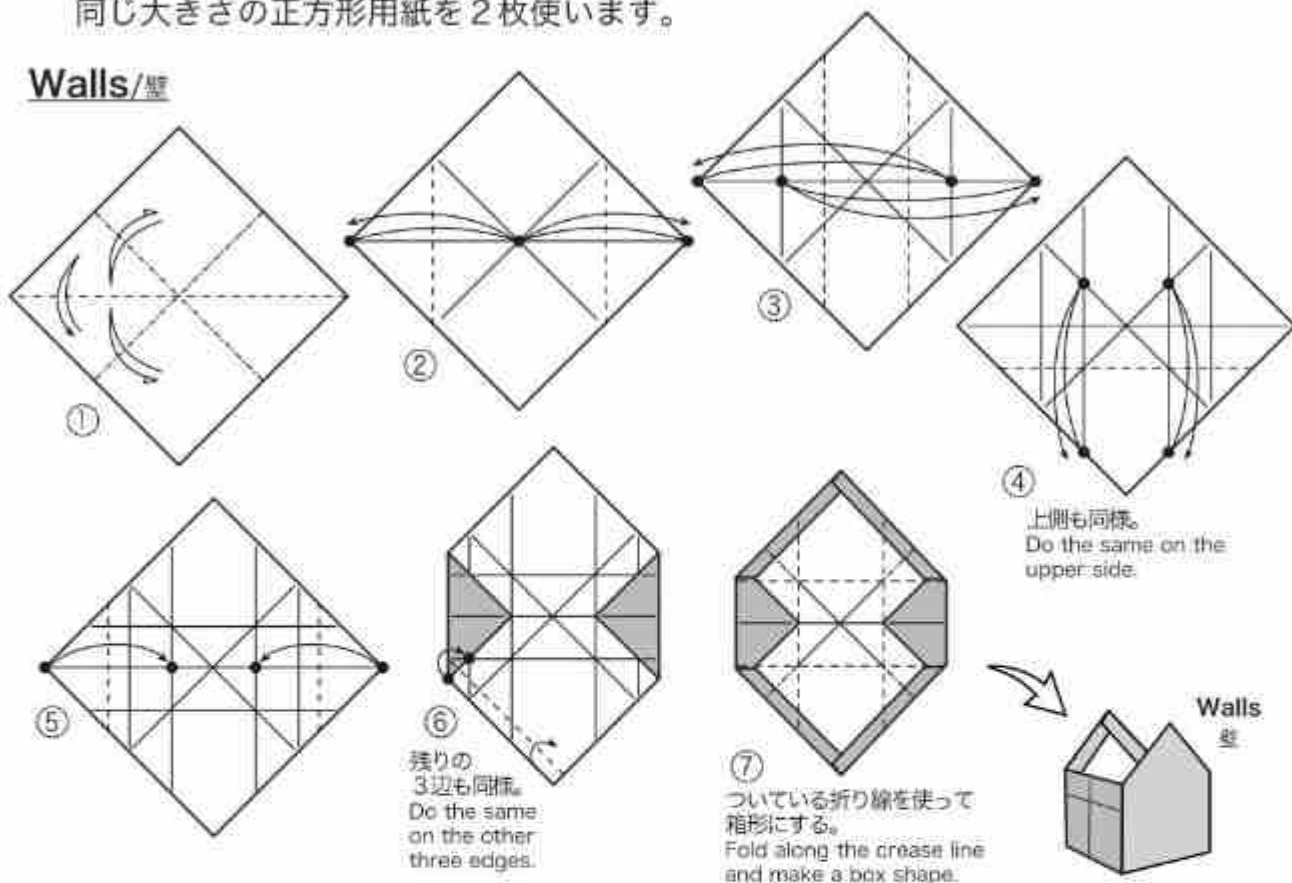

By changing the ratio at step ⑤, we can create walls with different heights.
⑤の比率を変えると高さの違う壁が作れます。

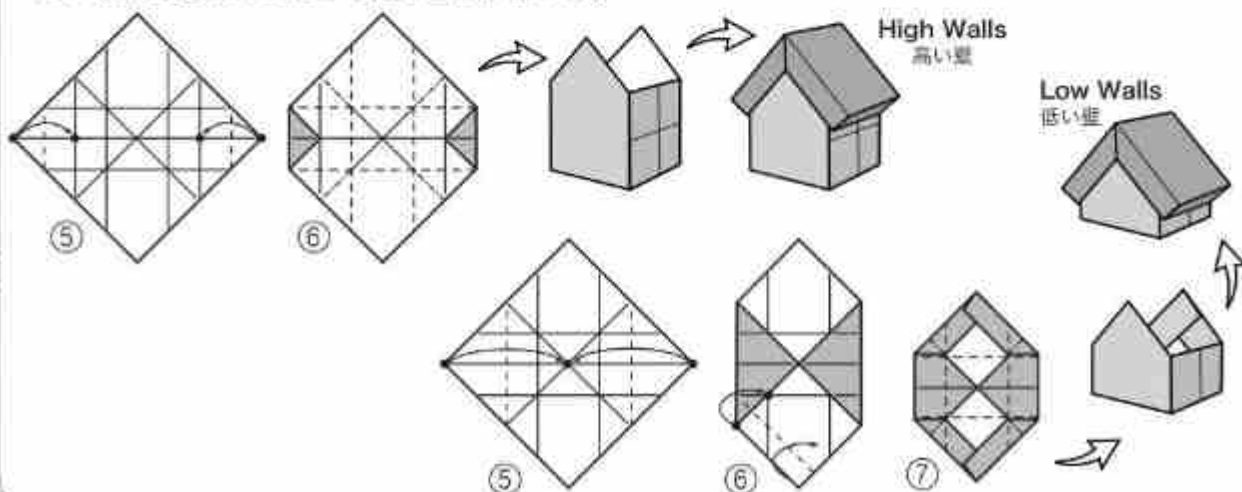

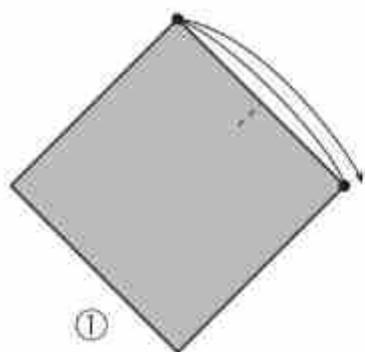

①

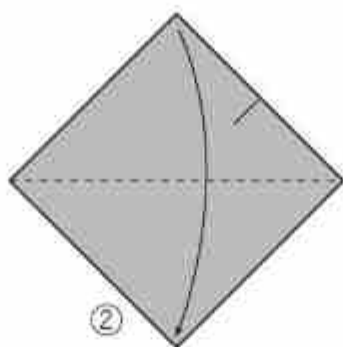

②

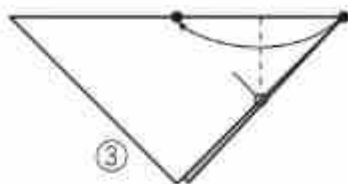

③

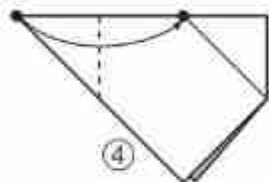

④

⑤ 裏も同じ。
Do the same
on the backside.

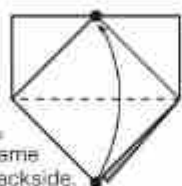

⑤

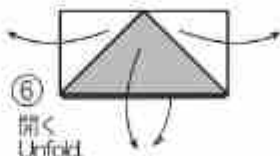

⑥

開く
Unfold

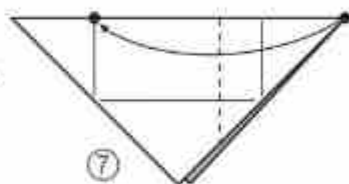

⑦

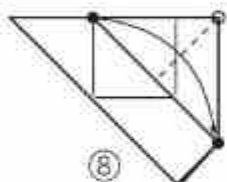

⑧

左側にも⑦、⑧と同じ
折り目をつける。
Do the same steps
⑦、⑧ on the left side.

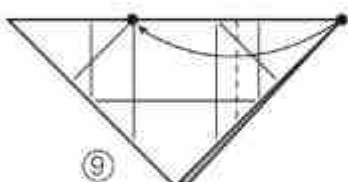

⑨

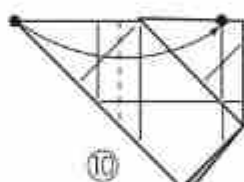

⑩

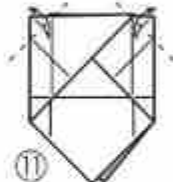

⑪

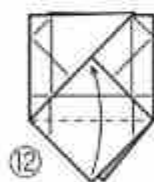

⑫

裏も同じ。
Do the same on
the backside.



⑬

開く
Unfold

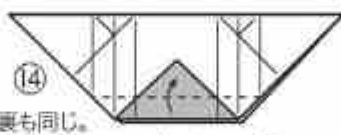

⑭

裏も同じ。
Do the same on the backside.

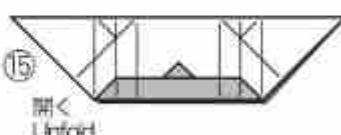

⑮

開く
Unfold

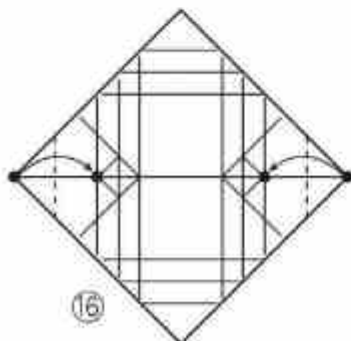

⑯

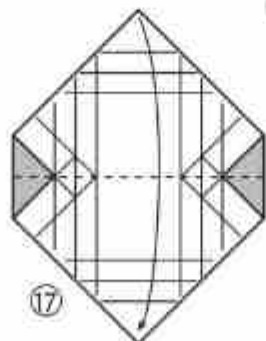

⑰

図を拡大。
Image is enlarged.

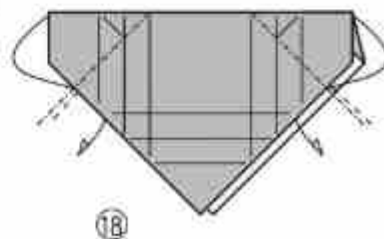

⑱

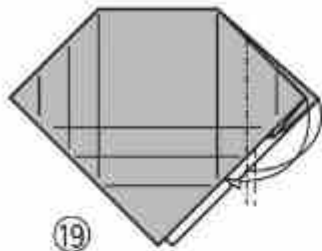

①9

2つのカドを揃えたまま、
ついている折り目を使って
内側へ押し込む。
With the two corners
aligned, push inward
using the crease lines.

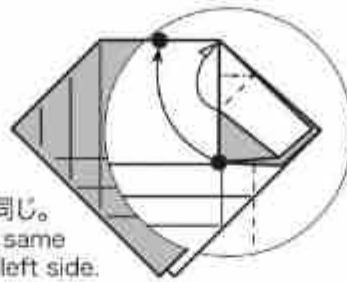

左側も同じ。
Do the same
on the left side.

中の様子
Inside view.

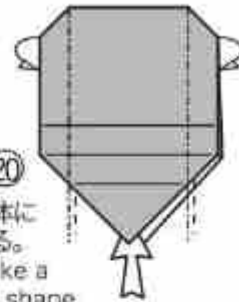

②0

立体に
する。
Make a
3D shape.

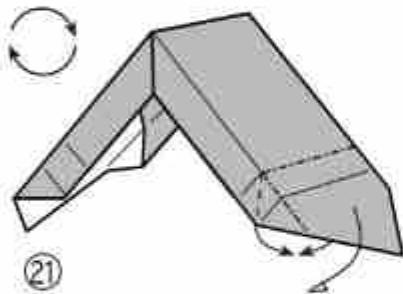

②1

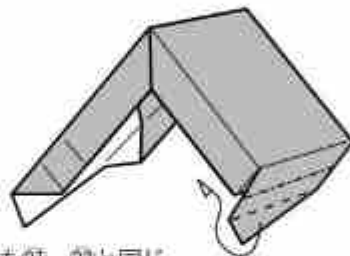

②2

左側も②1、②2と同じ。
Do the same steps
②1, ②2 on the left side.

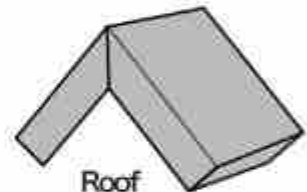

Roof
屋根

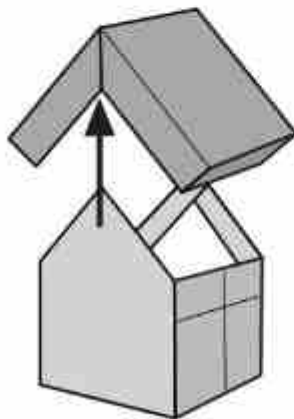

House
家

Little Circus

Miyuki Kawamura

©2019 - Japan

Intermediate

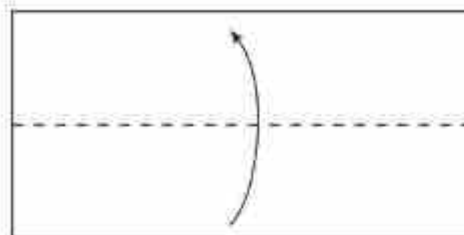

②



③

① 1 : 2の長方形用紙より。
1 by 2 rectangular paper.

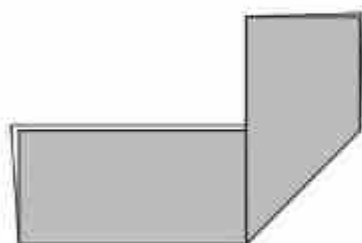

④

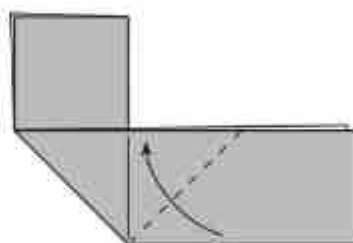

⑤

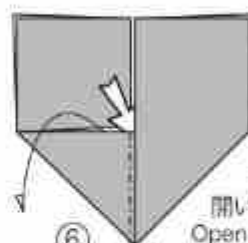

⑥

中央の
ポケットを
開いてつぶす。
Open the center
pocket and squash.

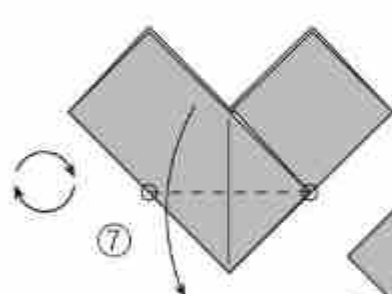

⑦

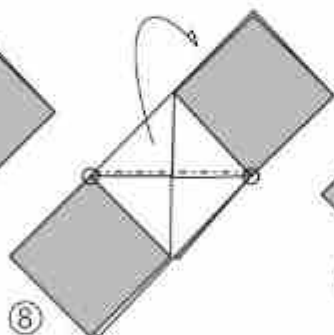

⑧

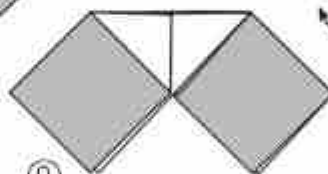

⑨

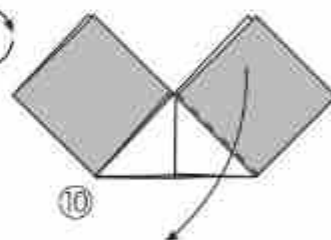

⑩

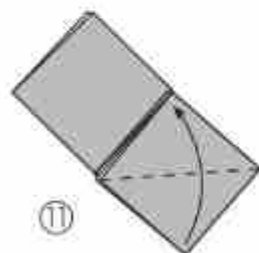

⑪

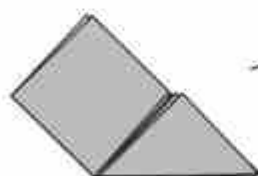

⑫

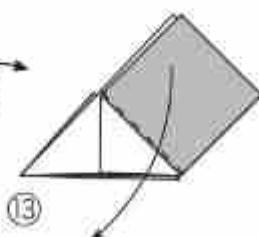

⑬

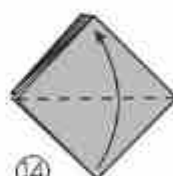

⑭



⑮

開く。
Unfold.

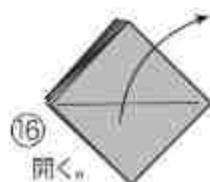

⑯

開く。
Unfold.

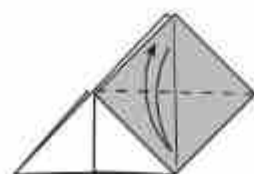

⑰

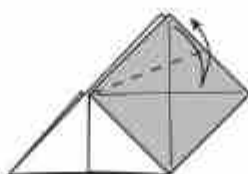

⑱

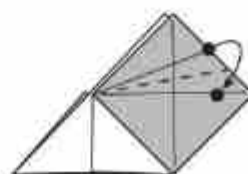

⑲

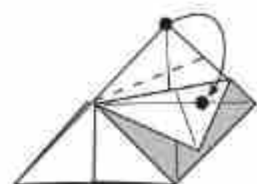

⑳

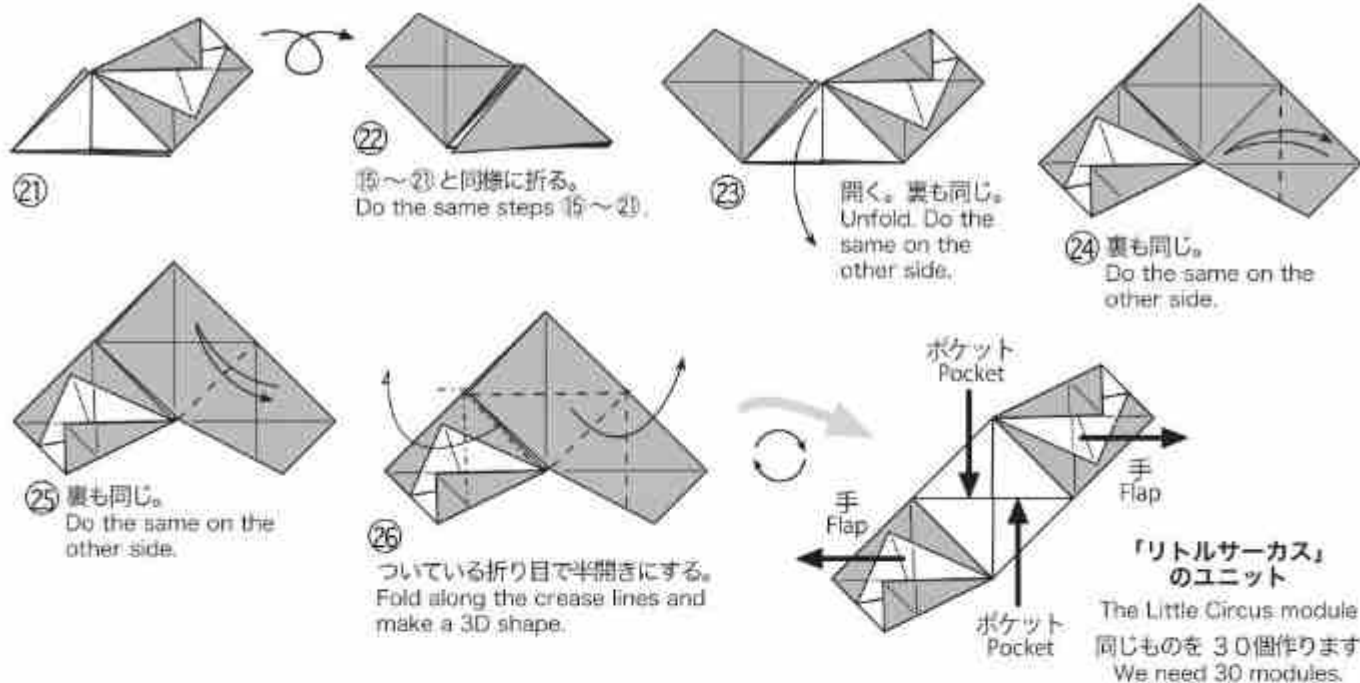

Assmblly/組み方

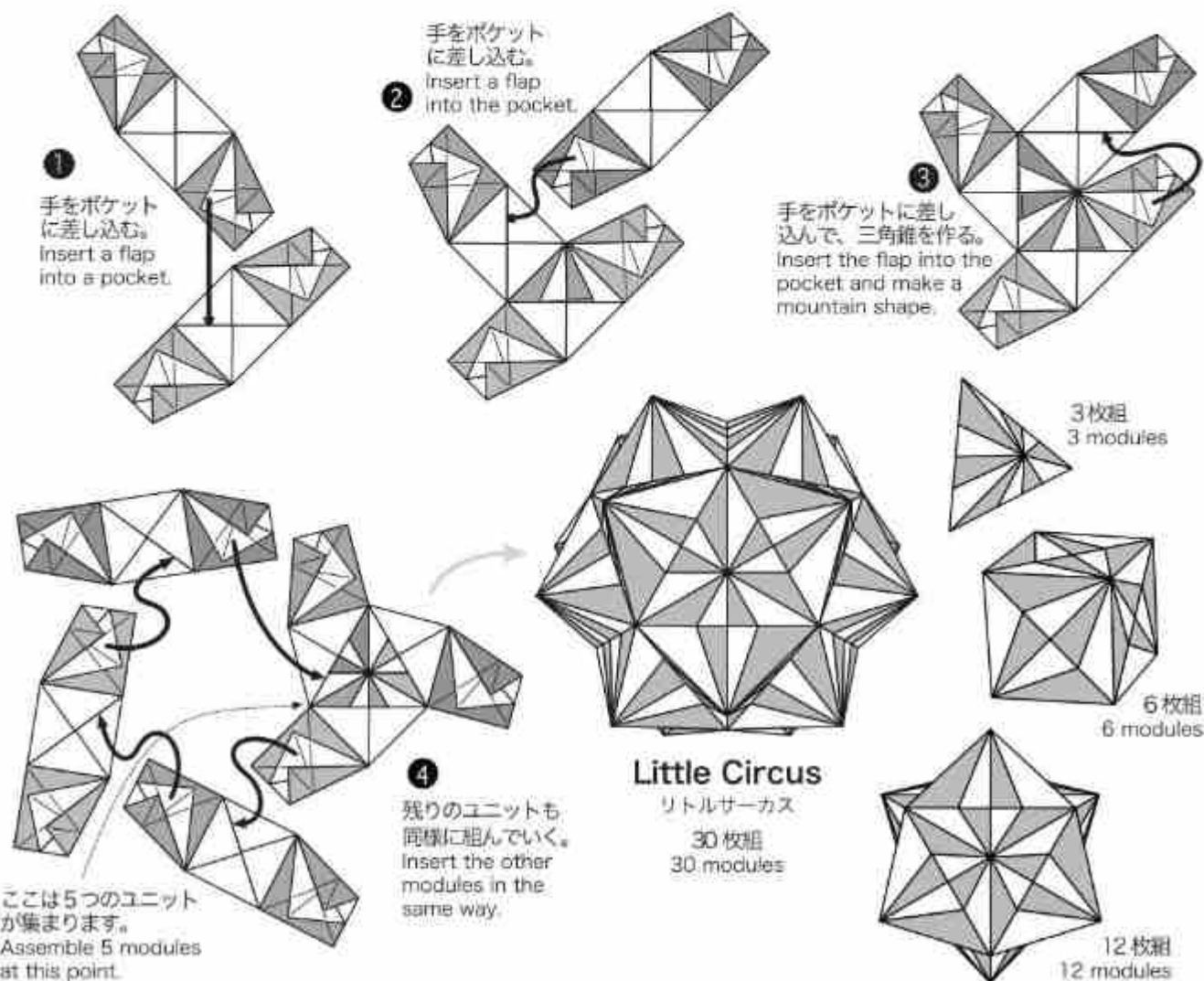

● We can make skeleton models if we skip the step 25.

工程 25 を山折のままにしておくと、面が凹んだスケルトン状の立体が作れます。

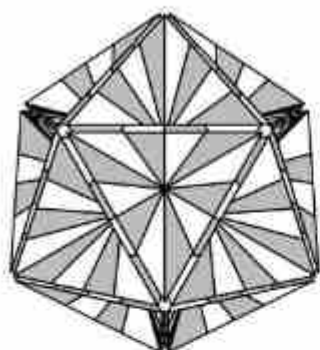

30 枚組
30 modules

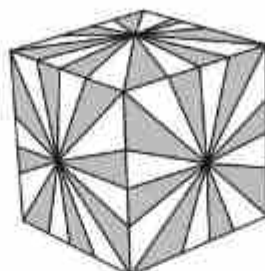

12 枚組
12 modules

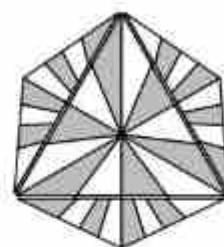

12 枚組
12 modules

● On the steps 17 ~ 22, we can change the ratios and angles to make different pattern on the model.

工程 17 ~ 22 で、折る幅や角度を変えるといろいろな模様が作れます。

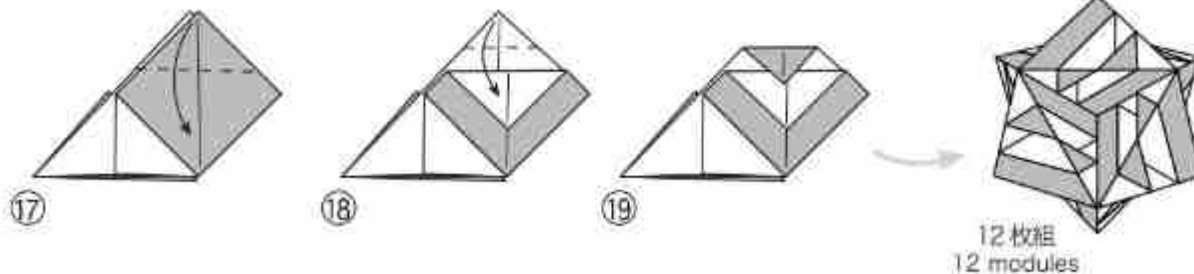
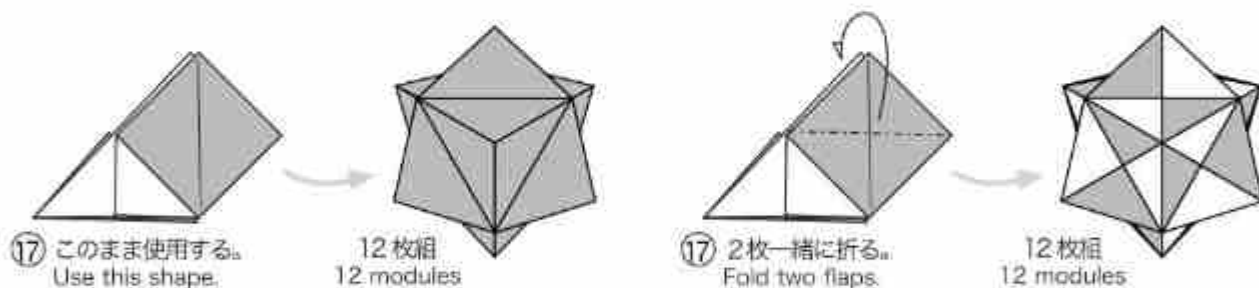

Winged Heart with Horns

Allan Kenedy

©2013 - Brazil

High Intermediate

Recommended size: 20 cm x 20 cm

Eu criei este modelo baseado no "Coração alado" de Francis Ow e no "Coração chifrado" de Tadashi Mori.

I created this model based on Francis Ow's "Winged heart" and Tadashi Mori's "Horned heart".

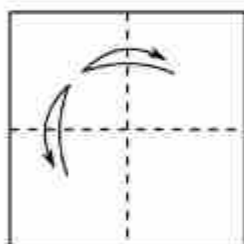

1. Lado branco para cima.
Dobre o papel ao meio.
White side up. Fold the paper in half.

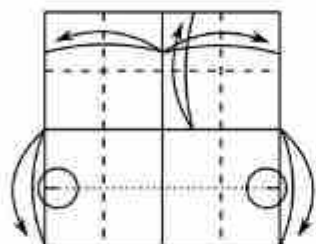

2. Dobre como indicado.
Vingue apenas onde está
circulado.
*Fold as shown. Crease
only where it is circled.*

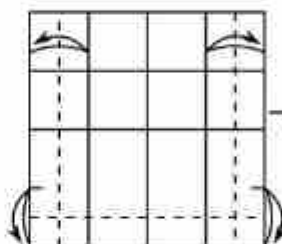

3. Dobre como indicado.
Vire o papel.
*Fold as shown. Turn over
the paper.*

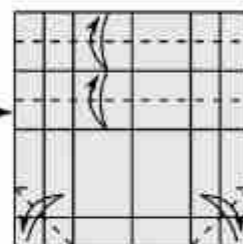

4. Dobre como indicado.
Vire o papel.
*Fold as shown. Turn over
the paper.*

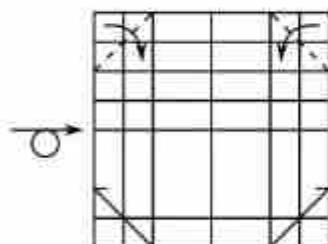

5. Dobre como indicado.
Fold as shown.

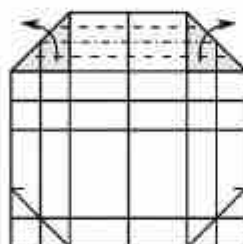

6. Dobre como indicado.
Desdobre.
Fold as shown. Unfold.

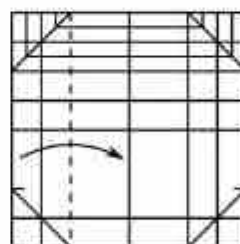

7. Dobre como indicado.
Fold as shown.

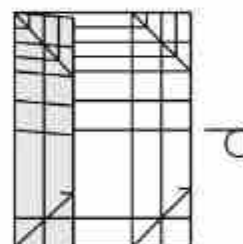

8. Vire o papel.
Turn over the paper.



9. Dobre como indicado.
Fold as shown.

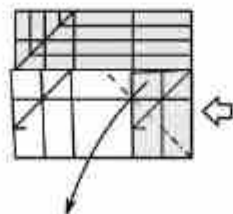

10. Esmague o papel.
Squash fold the paper.

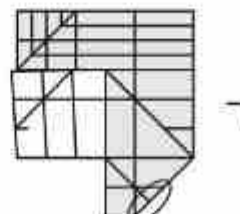

11. Não vingue esta parte.
Vire o papel
*Don't crease this part. Turn
over the paper.*

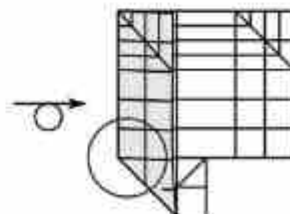

12. Foco nesta parte
Focus on this part.

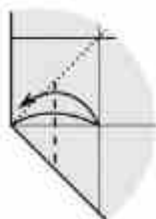

13. Dobre e desdobre.
Tome como referência o
vinco de trás.
*Fold and unfold. Take the
crease behind as a
reference.*

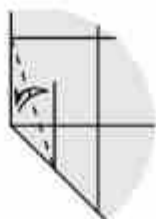

14. Dobre como indicado.
Vire o papel.
*Fold was shown. Turn over
the paper.*

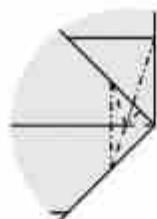

15. Afunde aberto.
Open sink.

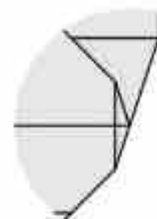

16. Desdobre tudo.
Unfold everything.

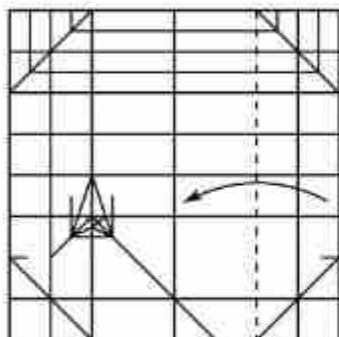

17. Repita os passos 7-16 no lado
direito.
*Repeat the steps 7-16 on the right
side.*

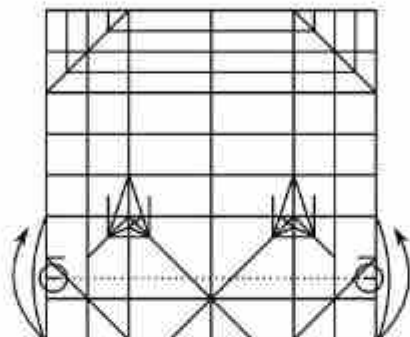

18. Dobre como indicado: Vinque
apenas onde está circulado.
*Fold was shown. Crease only where
it is circulated.*

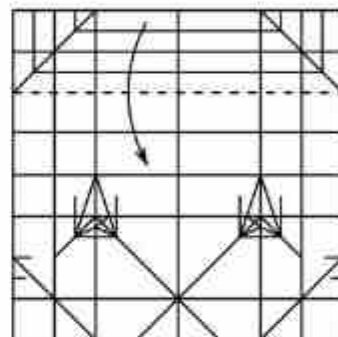

19. Fim das dobras iniciais. Dobre
como indicado.
*End of the initial folds. Fold as
shown.*

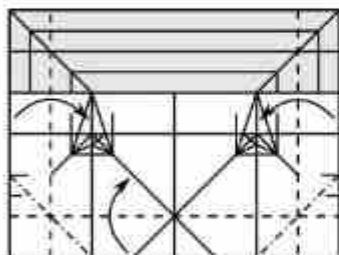

20. Dobre como indicado.
Fold was shown.

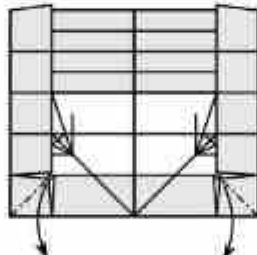

21. Dobre as pontas para baixo.
Fold the ends down.

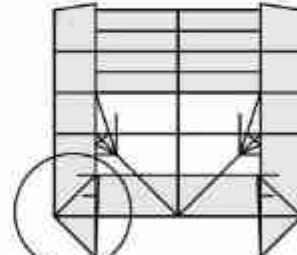

22. Foco nesta parte
Focus on this part.

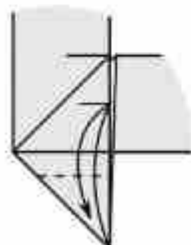

23. Dobre e desdobre.
Fold and unfold.

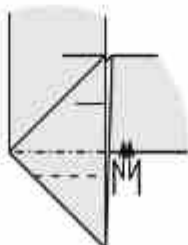

24. Crimpe.
Crimp.

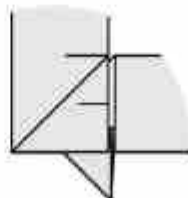

25. Gire 180°.
Rotate 180°.

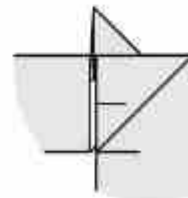

26. Visão de raios-x.
X-ray view.

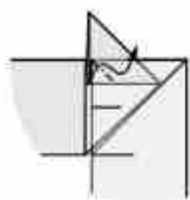

27. Dobra reversa para dentro.
Inside reverse fold.

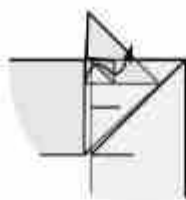

28. Faça a mesma coisa atrás.
Do the same thing behind.



29. Ignore a camada frontal.
Ignore the front layer.

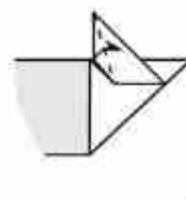

30. Dobre como indicado.
Fold as shown.



31. Deslize o papel extra para a direita.
Slip the extra paper to the right.



32. Saia da visão de raios-x.
Get out of x-ray vision.

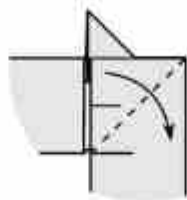

33. Dobre a aba como indicado.
Fold the flap as shown.

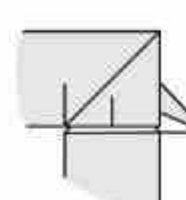

34. Repita os passo 27-32.
Repeat the steps 27-32.

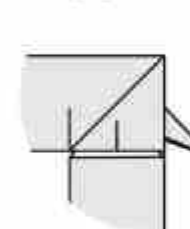

35. Saia da visão ampliada. Gire o papel.
Get out of the zoom view. Rotate the paper.

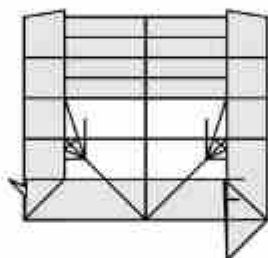

36. Repita os passos 23-35 no lado direito.
Repeat the steps 23-35 on the right side.

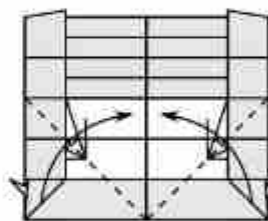

37. Dobre como indicado.
Fold as shown.

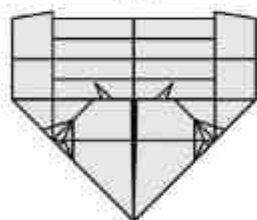

38. Vire o papel.
Turn over the paper.



39. Dobre o papel para baixo.
Fold the paper down.

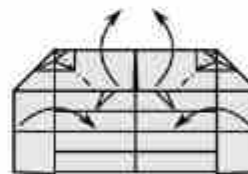

40. Dobre os cantos para cima ao mesmo tempo em que dobra as laterais para o centro.
Fold the corners upwards at the same time folding the sides towards the center.

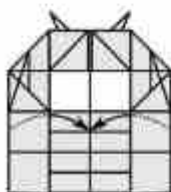

41. Retire a camada de papel escondida.
Remove the hidden paper layer.

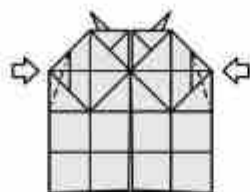

42. Afunde o papel como no passo 15.
Sink the paper as in step 15.

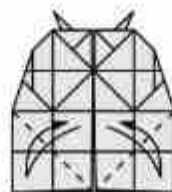

43. Dobre como indicado.
Fold as shown.

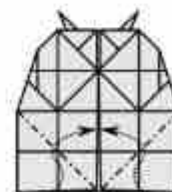

44. Dobra reversa para dentro.
Inside reverse fold.

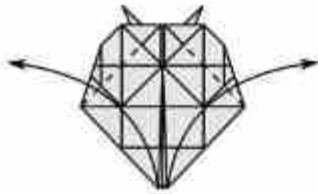

45. Dobre as pontas para fora.
Fold the ends out.

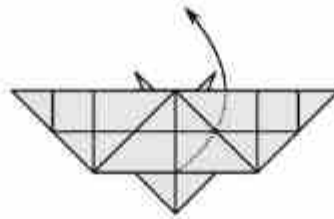

46. Puxe o papel escondido.
Pull out the hidden paper.

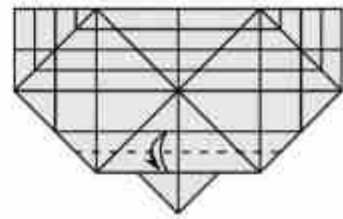

47. Dobre e desdobre.
Fold and unfold.

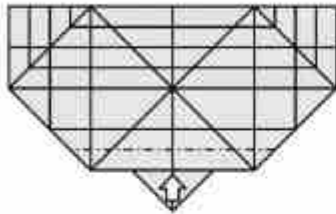

48. Afunde fechado.
Closed sink.

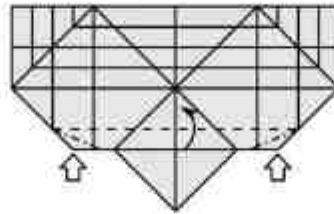

49. Dobre e esmague.
Squash fold.

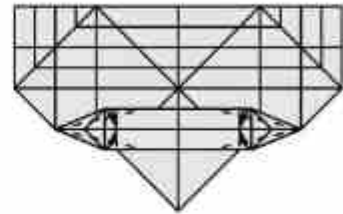

50. Dobre como indicado.
Fold was shown.

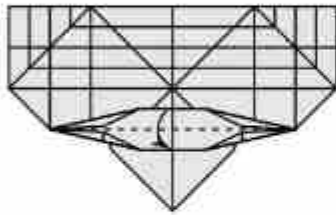

51. Dobre para baixo.
Fold down.

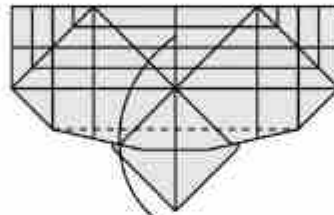

52. Dobre para baixo.
Fold down.

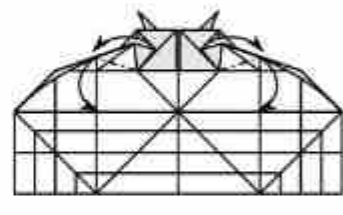

53. Dobre como indicado, tornando o papel plano.
Fold was shown, making the paper flat.

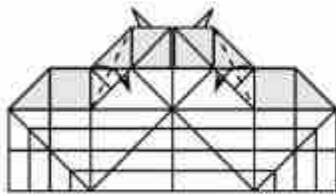

54. Dobre como indicado.
Fold was shown.

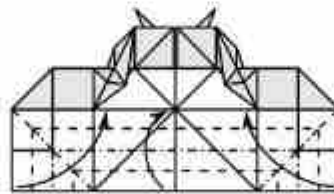

55. Dobre como indicado.
Fold was shown.

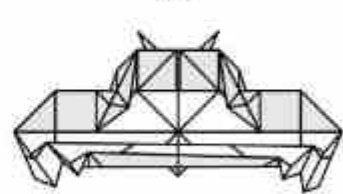

56. Em progresso.
In progress.

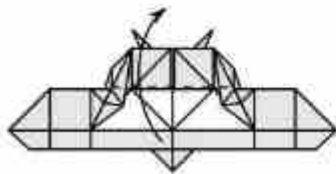

57. Dobre para cima.
Fold up.

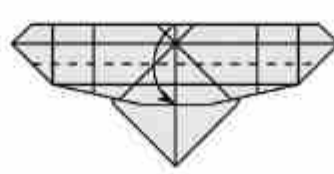

58. Dobre para baixo.
Fold down.

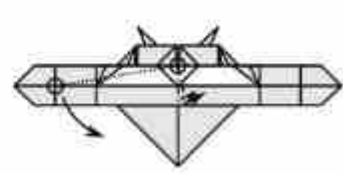

59. Gire a aba. O vinco de trás é uma dobra em montanha.
Pivot the flap. The crease behind is a mountain fold.

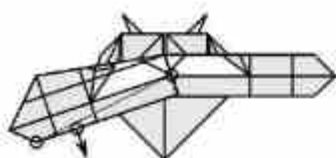

60. Puxe a camada interna formando uma dobra em montanha entre os pontos circutados.
Pull the inner layer forming a mountain fold between the circled points.

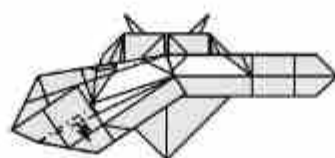

61. Dobre plissado, planejando o papel.
Pleat fold, planning the paper.



62. Dobre como indicado.
Fold as shown.

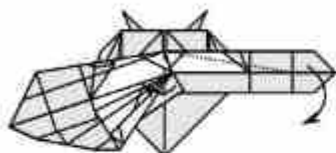

63. Repita os passos 59-62 no lado direito.
Repeat the steps 59-62 on the right side.

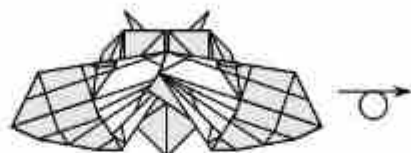

64. Vire o papel.
Turn over the paper.

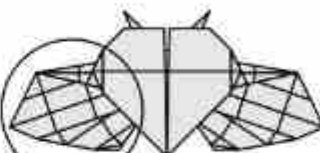

65. Foco nesta asa.
Focus on this wing.

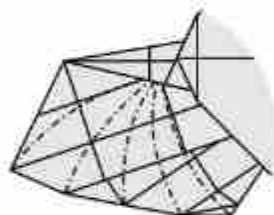

66. Faça dobras em montanha curvadas.
Make curved mountain folds.

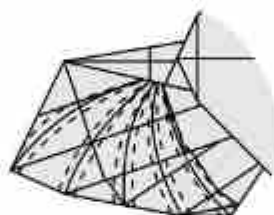

67. Faça dobras em vale curvadas.
Make curved valley folds.



68. Modele a asa.
Shape the wing.

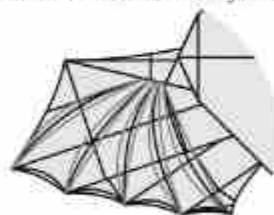

69. Saia da visão ampliada.
Get out of the zoom view.

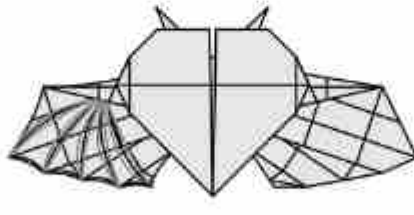

70. Repita os passos 65-69 na outra asa.
Repeat the steps 65-69 on the other wing.

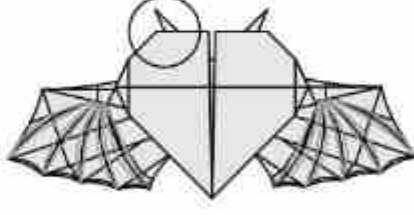

71. Foco no chifre.
Focus on the horn.



72. Curve o chifre.
Curve the horn.



73. Saia da visão ampliada.
Get out of the zoom view.

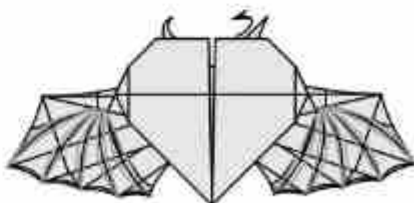

74. Curve o outro chifre.
Curve the other horn.

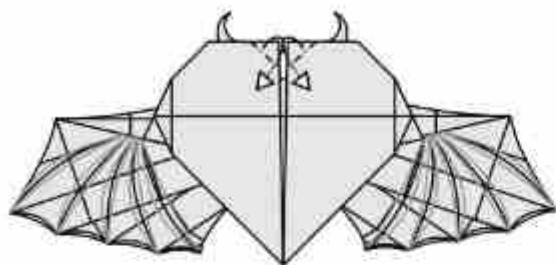

75. Dobre as abas para trás.
Fold the flaps back.

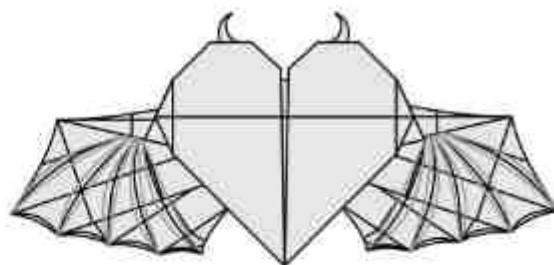

76. Modelo finalizado.
Finished model.

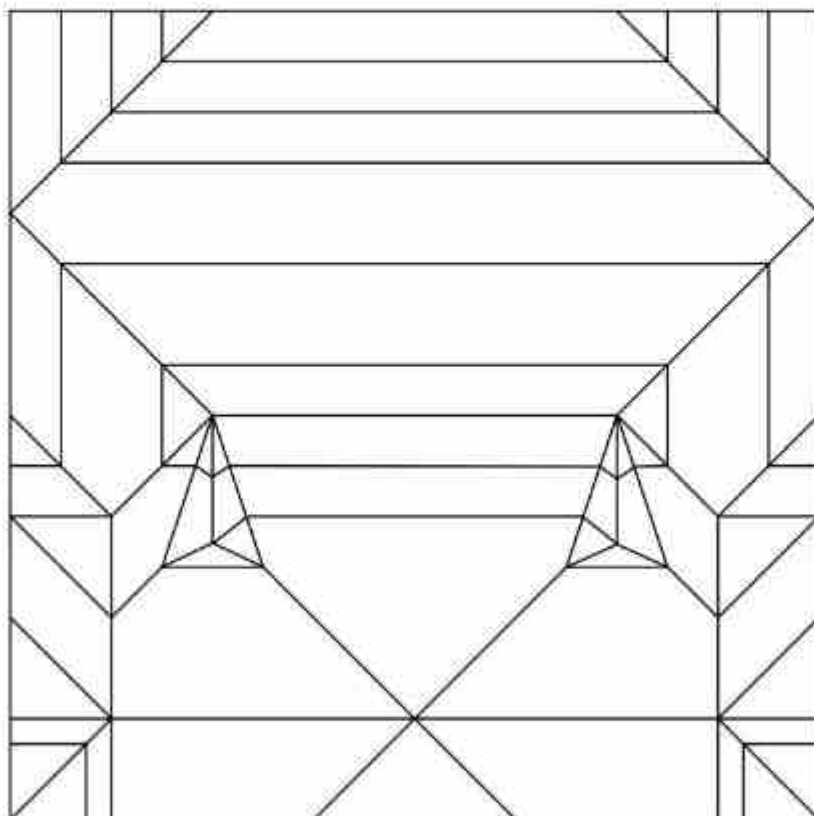

Padrão de vincos - *Crease pattern*

Windmill Flower

Mahyar Hossein Khani

©2020 - Iran

Intermediate

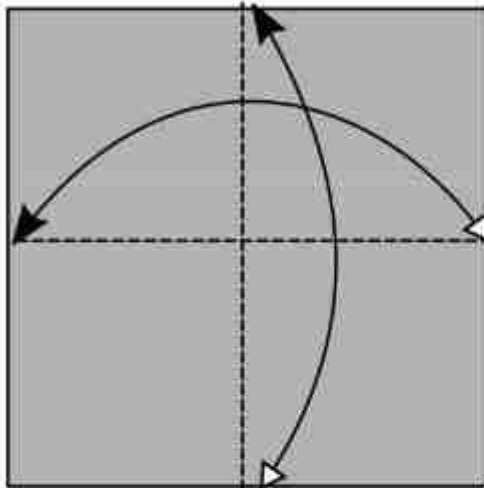

1. Precrease.

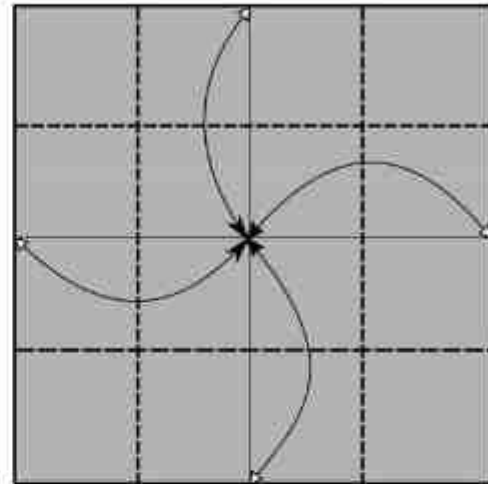

2. Precrease. Turn over.

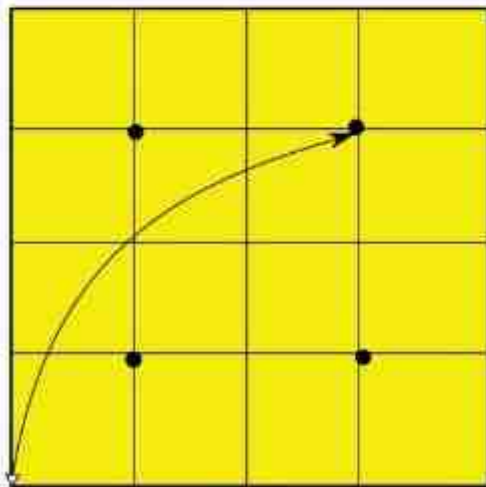

3. Precrease to the corner and repeat.

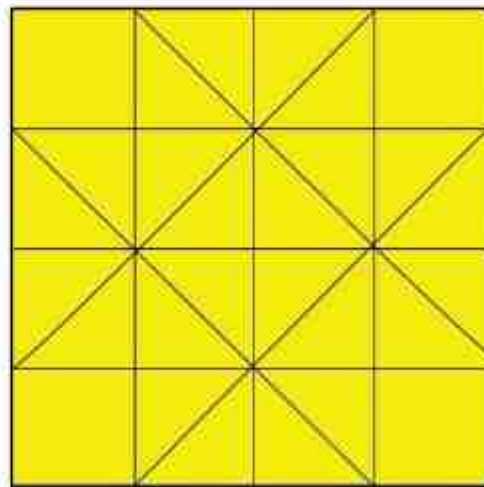

4. The result.

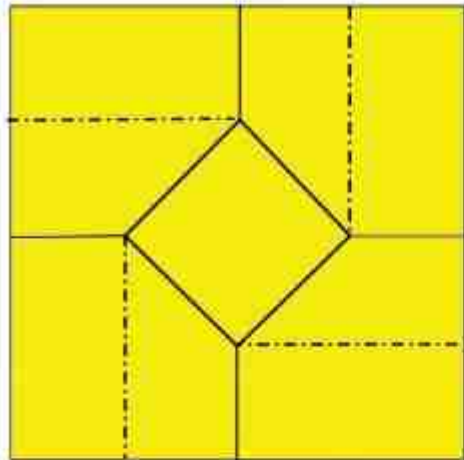

5. Square twist.

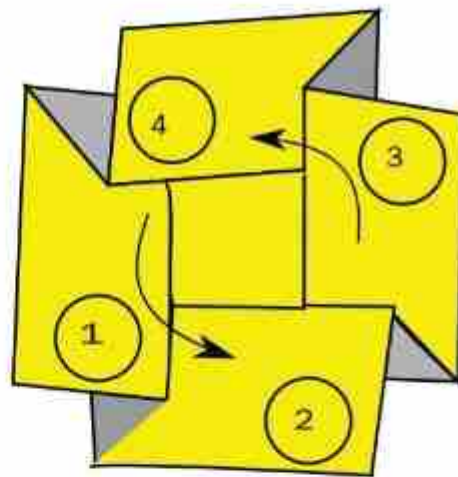

6. In progress...

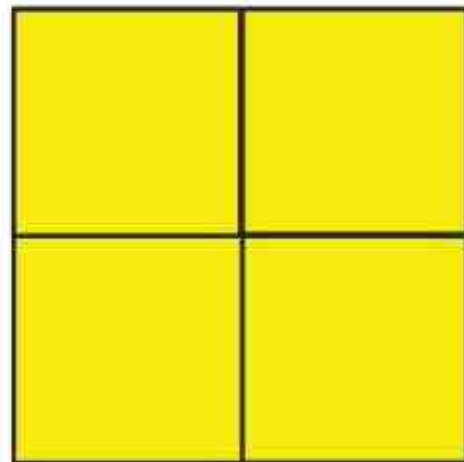
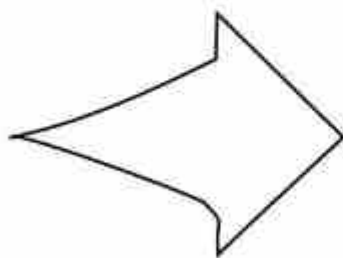

7. Turn over.

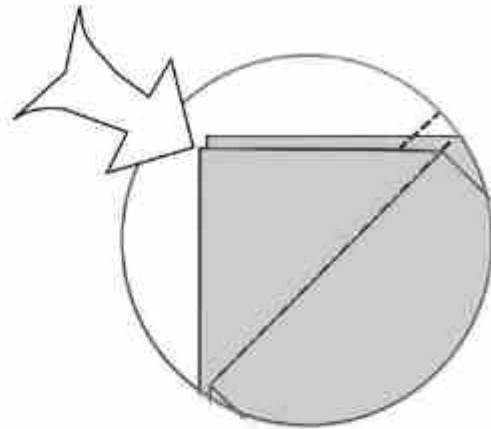
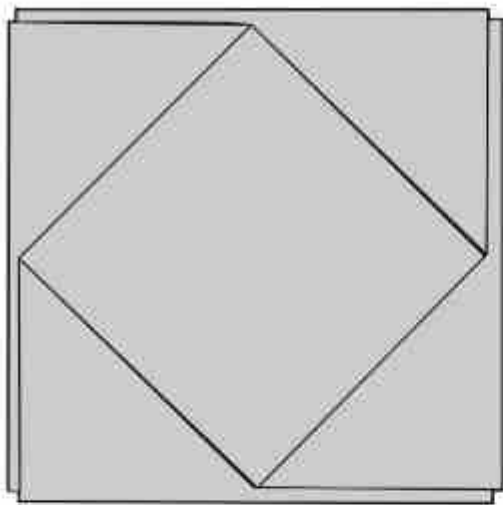

8. Reverse fold and repeat on other corners.
Turn over.

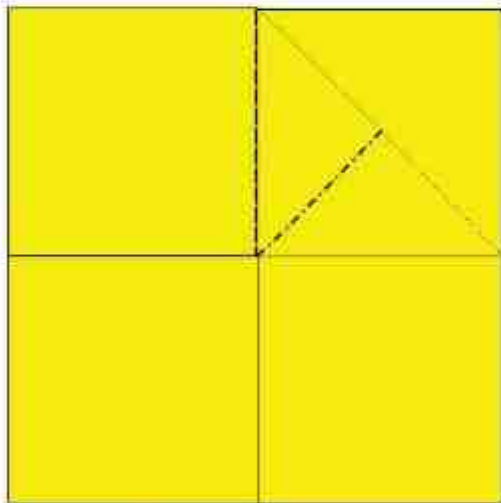

9. Reverse fold and repeat on other corners.
Turn over.

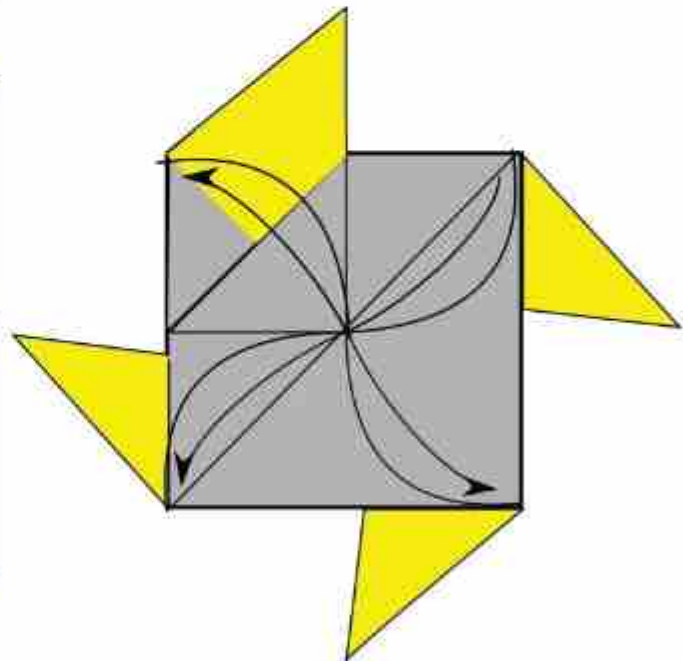

10. Precrease the corners.

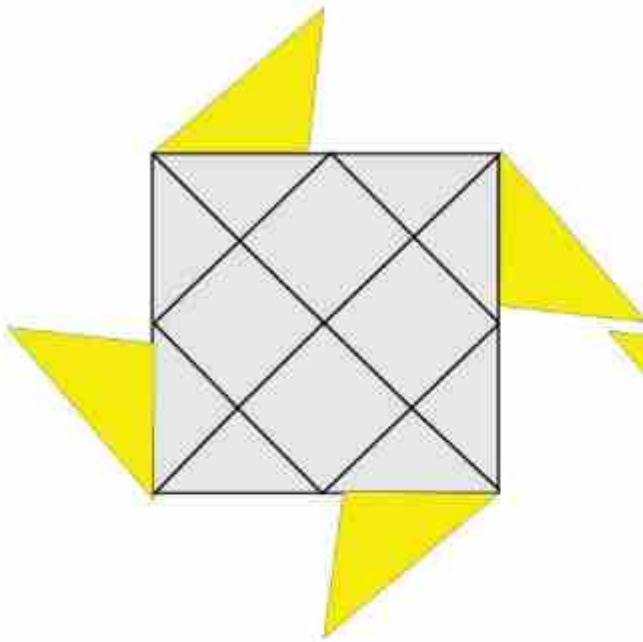

11. The result.

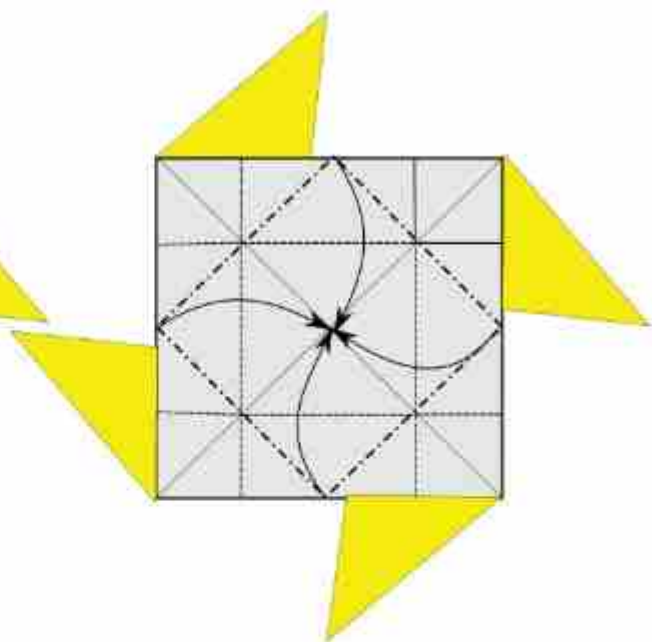

12. Squash fold the flaps.

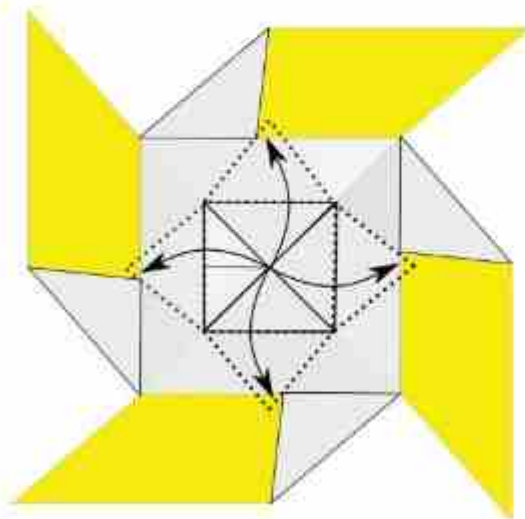

13. Open out the flaps.

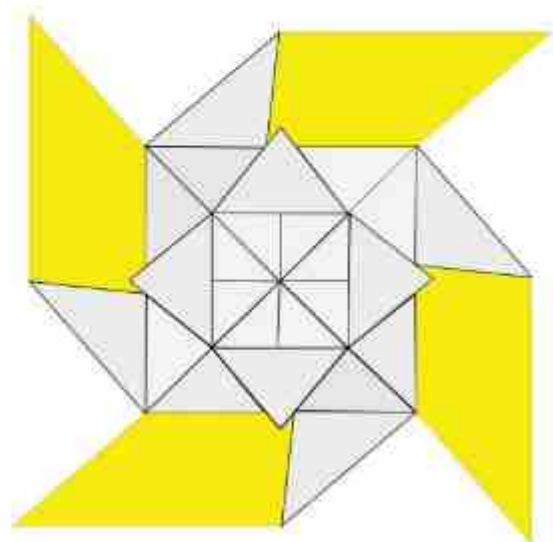

14. The model is done.

Squirrel

Marc Kirschenbaum

©2015 - USA

Intermediate

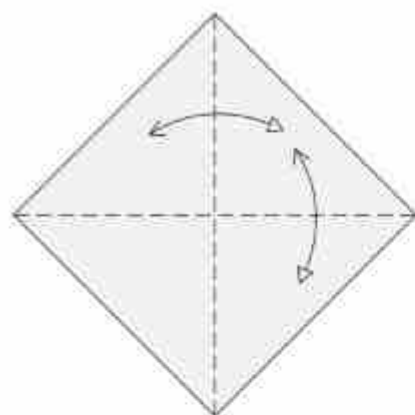

1. Precrease along the diagonals:

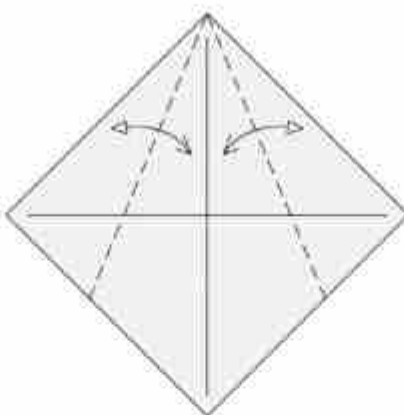

2. Precrease by folding to the center and unfolding.

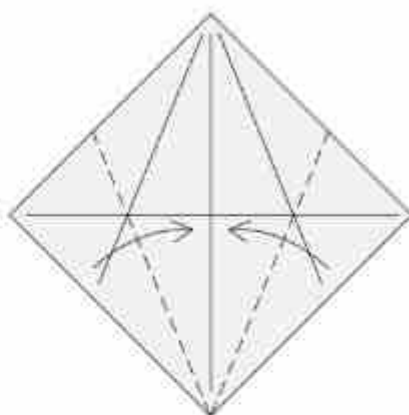

3. Valley fold the bottom edges to the center.

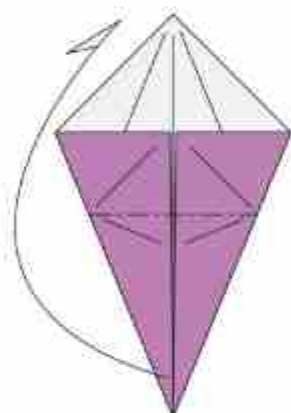

4. Mountain fold in half.

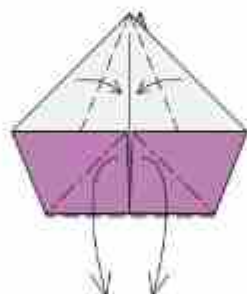

5. Pull the corners down, allowing the sides to get pulled towards the center.

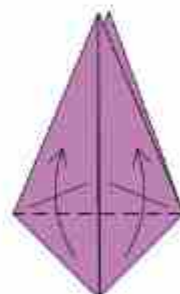

6. Valley fold the flaps up.

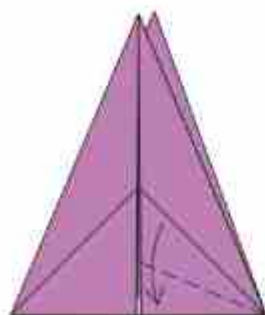

7. Valley fold the flap down.

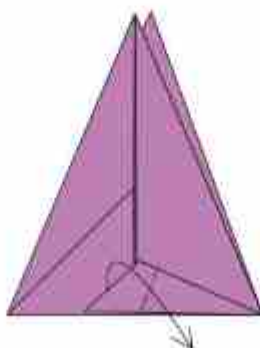

8. Valley fold, such that the side edge lies straight.

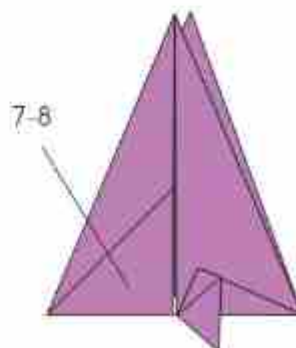

9. Repeat steps 7-8 in mirror image.

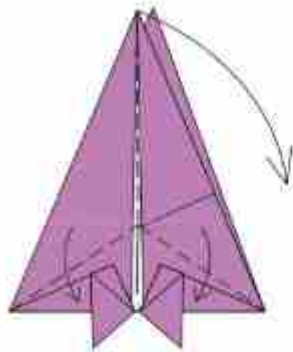

10. Valley fold the edges down, pinching the flap in half.

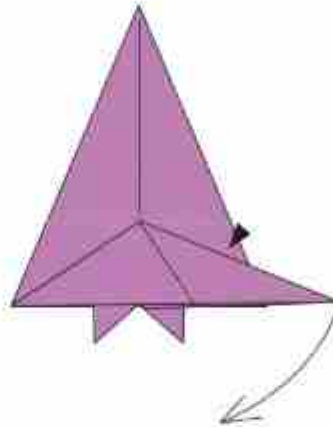

11. Reverse fold the flap down.

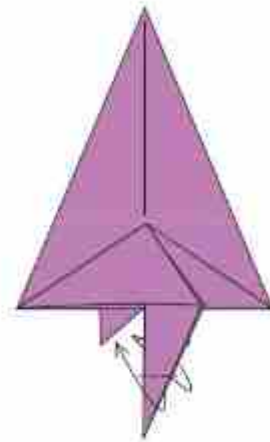

12. Outside reverse fold the tip of the flap.

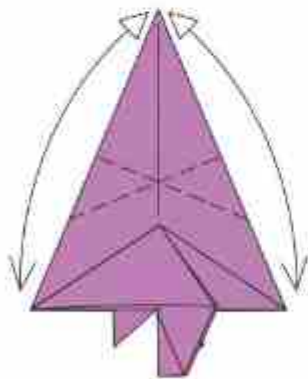

13. Precrease by bringing the top corner to the side corners.

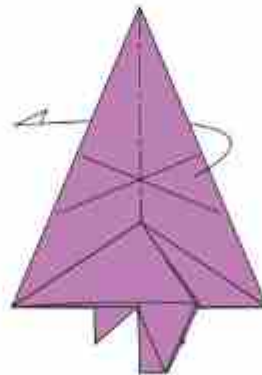

14. Mountain fold in half.

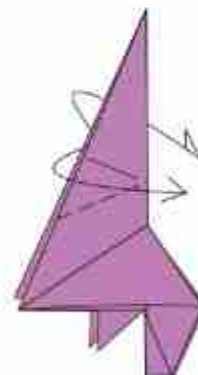

15. Outside reverse fold along the existing creases.

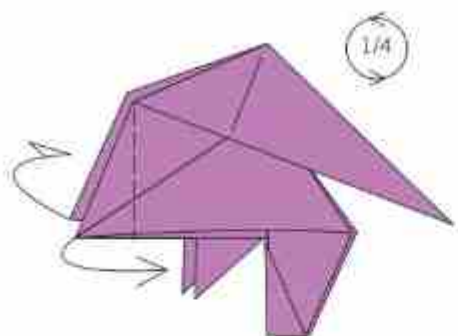

16. Valley fold the edges inwards. Rotate the model.

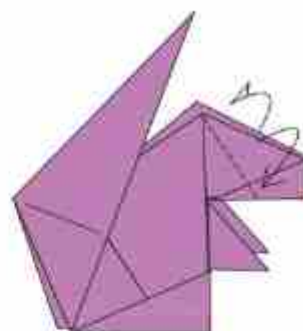

17. Outside reverse fold the head.

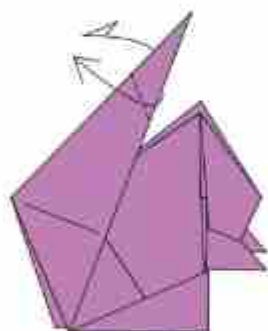

18. Outside reverse fold the tip of the flap.

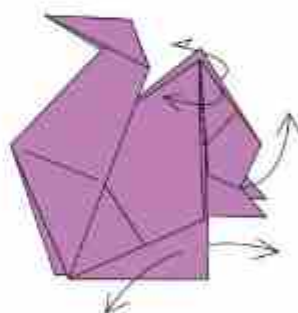

19. Pull the head up, while wrapping around the side edges of the ears. Open out the legs.

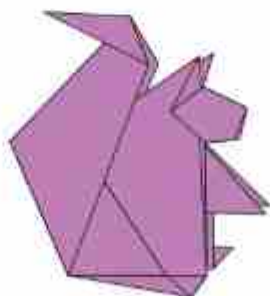

20. Completed *Squirrel*

創作 Created : 2020
作図 Diagrams : 2020

※表と裏の色が異なる紙を使用してください

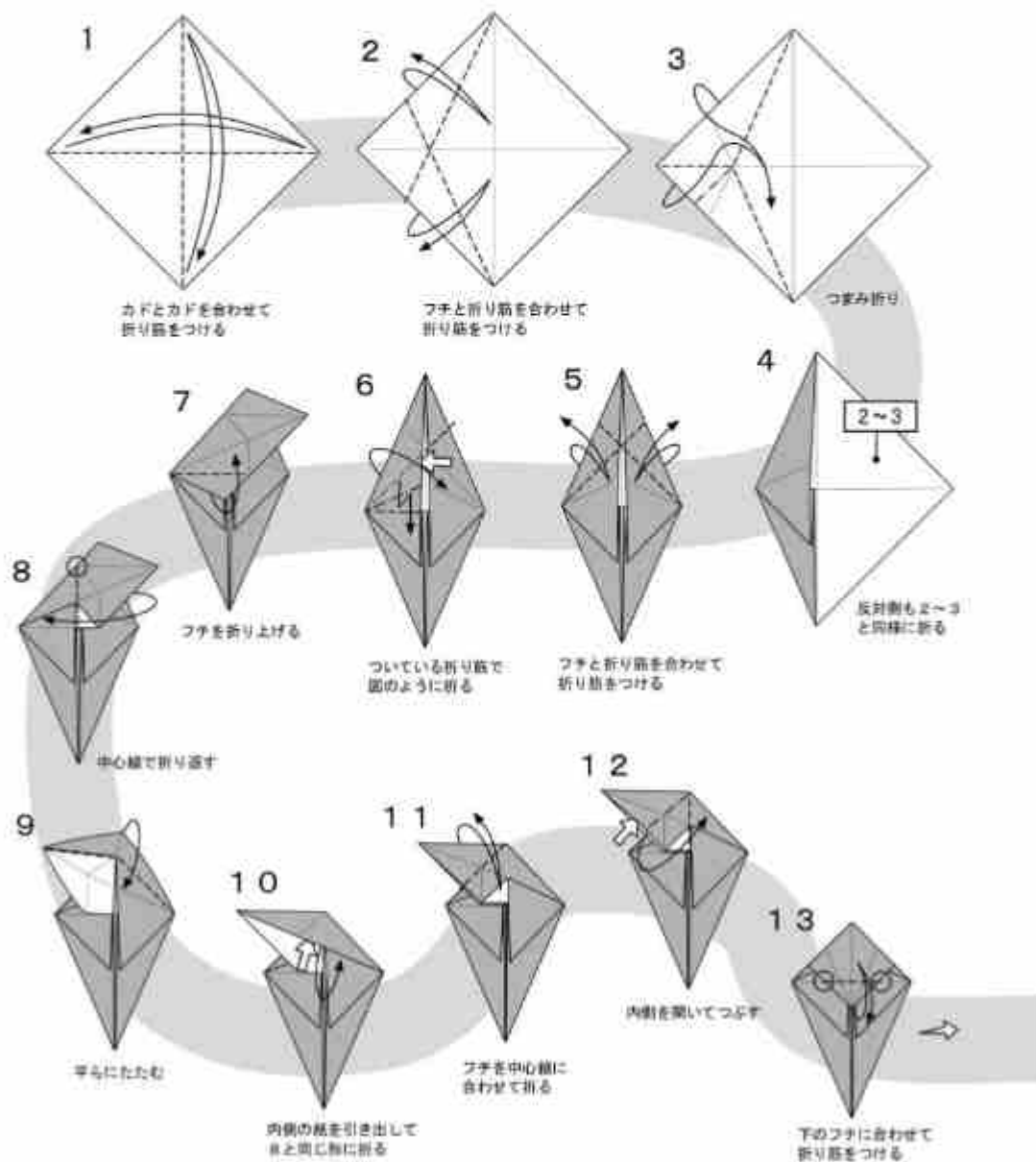
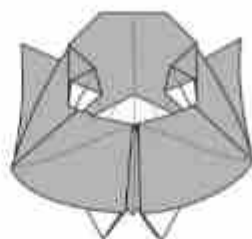

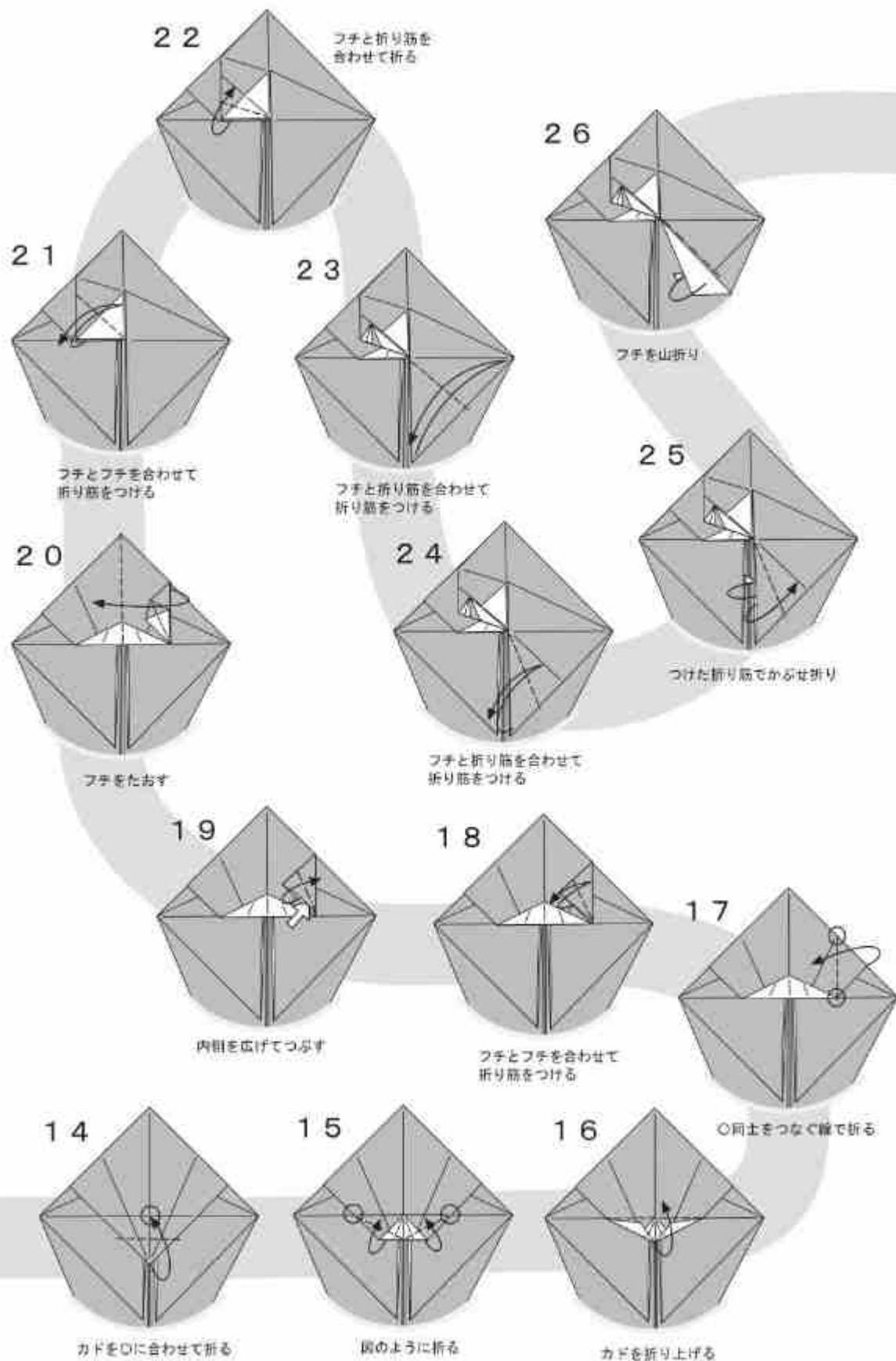

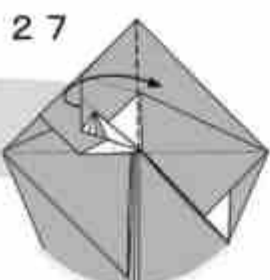

フチを戻す

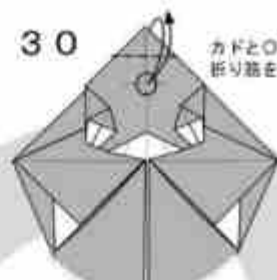

カドと○を合わせて
折り筋をつける

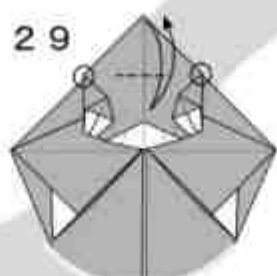

○同士を結ぶ線できく
折り筋をつける

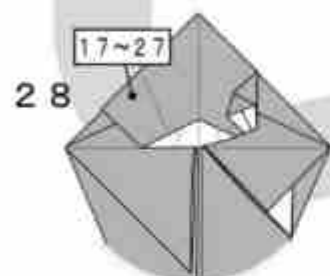

反対側も17~27と同様に折る

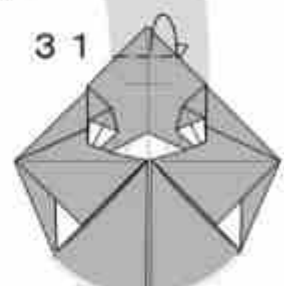

ついている折り筋で山折り

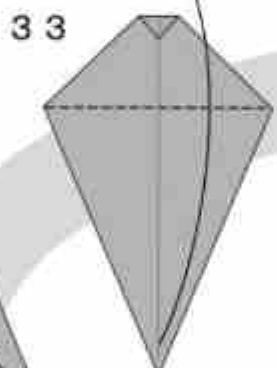
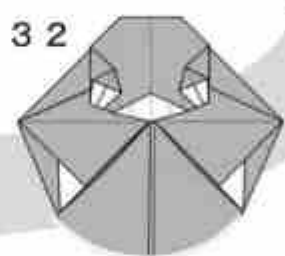

カドを折り上げる

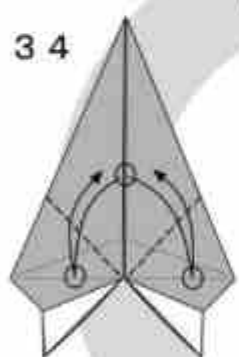

○同士を合わせて
折り筋をつける

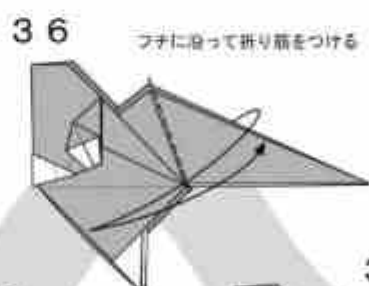

フチに沿って折り筋をつける

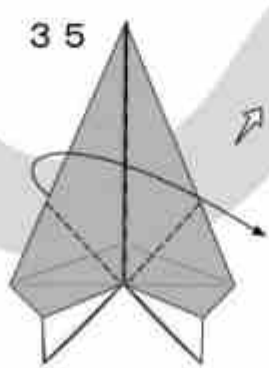

カドを中割り折りしながら
全体を半分に折る

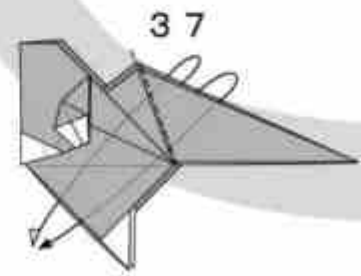

つけた折り筋でからせ折り

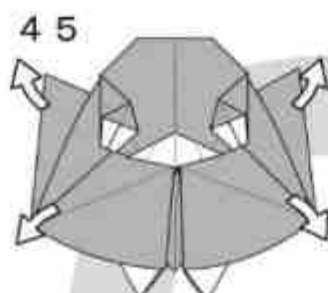

全体に丸みをつける



完成

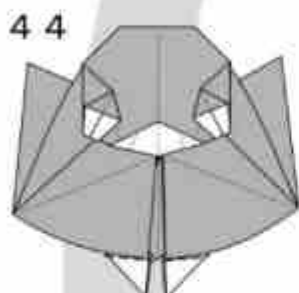

足を軽く折る

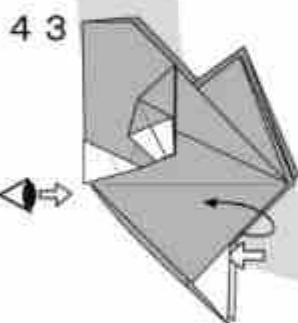
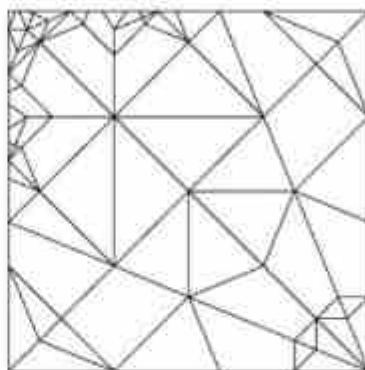

足と手前のフチを軽く開く
反対側も同様

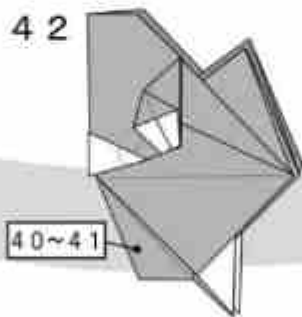

40~41

反対側も40~41と同様に折る

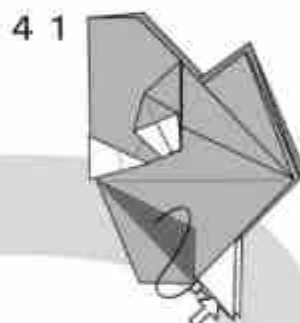

矢印のすき間にフチを差し込む
翻付けすると良い

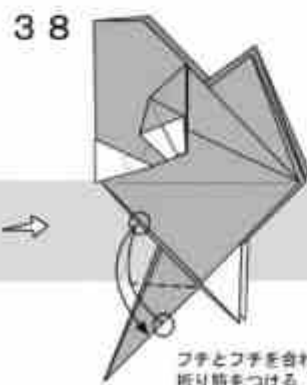

フチとフチを合わせて
折り筋をつける

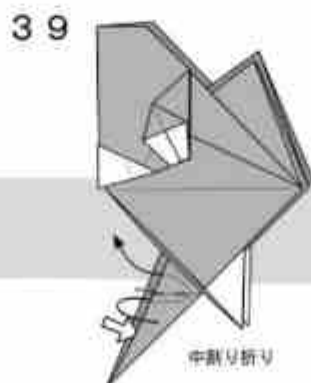

中割り折り

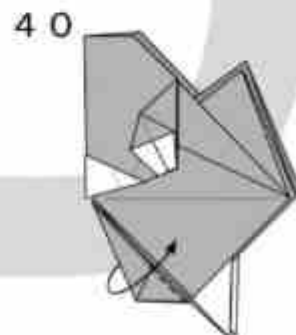

手前のフチをたおす

推荐纸张大小/Paper Size:50CM*50CM

准备一张黑白双色纸，白色为正面，然后16等份

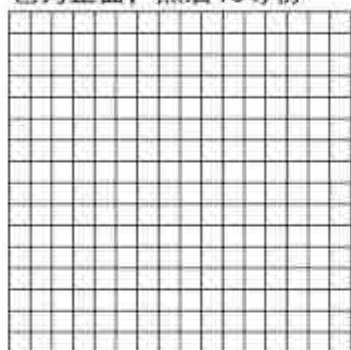

2.折好CP

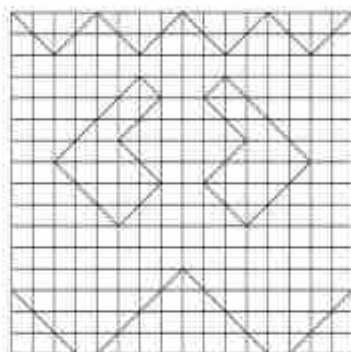

3.按峰谷折叠

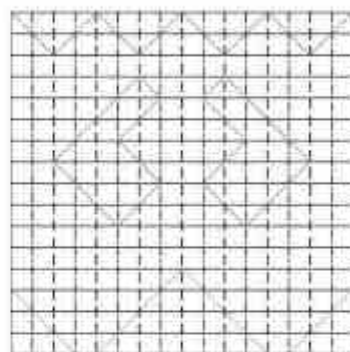

4.翻到左侧按照第5步的样子展开



5.按照峰谷折叠,两边同时进行

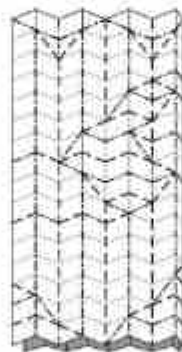

6.过程

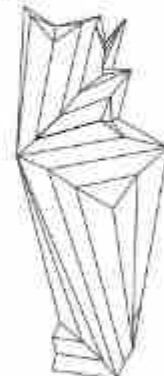

7.完成后的正面,接下来翻到背面

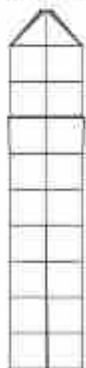

8.按谷线把前肢向上折

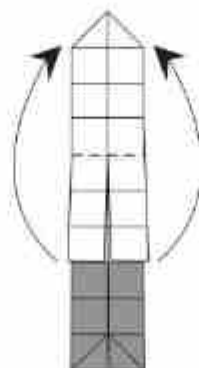

9.按峰谷把两层纸向上拉



10.按峰谷折叠使圆圈重合

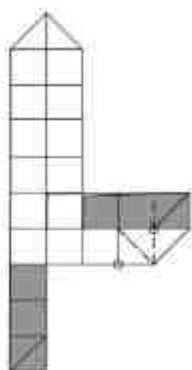

11.按峰线向下拉还原成第8步形态

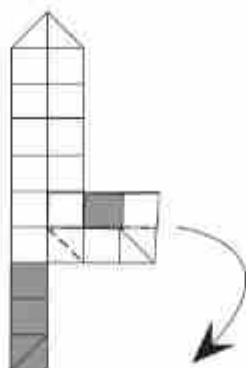

12.左侧重复9-11步

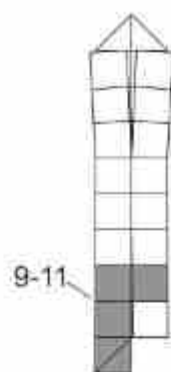

13.将两边前肢拉下来

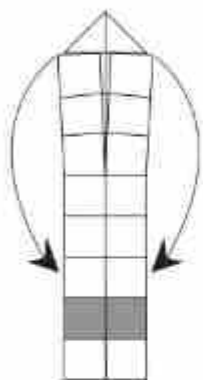

14.拉开2格纸



15.按照峰谷折下来

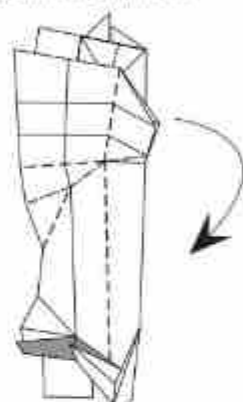

16.按照峰谷线折叠

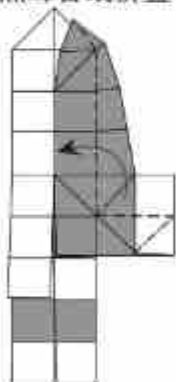

17.箭头处按峰谷折进去

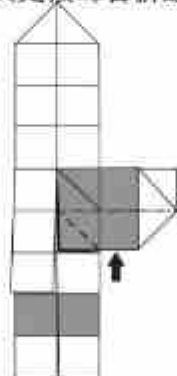

18.按谷线折上去

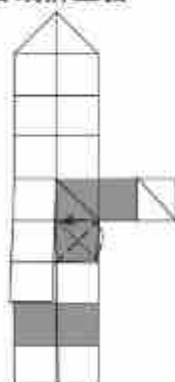

19.左侧重复14-18步

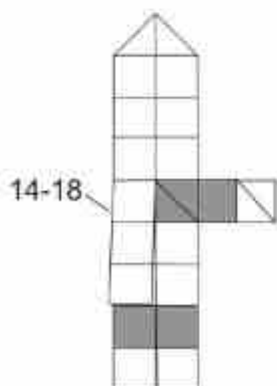

20.旋转180°

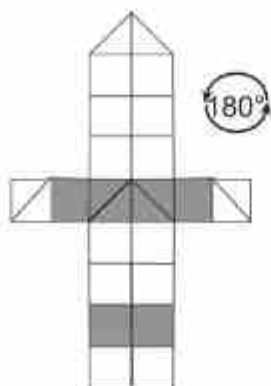

21.将下面的第一个分支向上翻

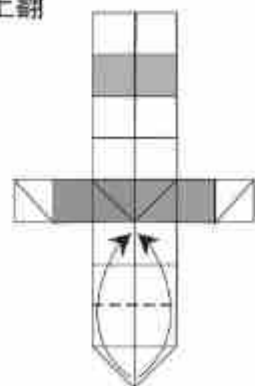

22. 向左拉使圆圈处重合

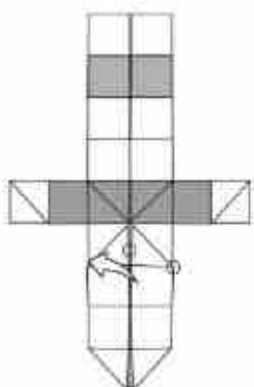

23. 另一侧重复22步

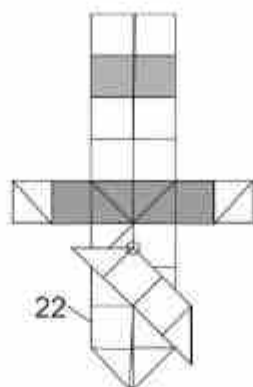

24. 按照谷线折上去

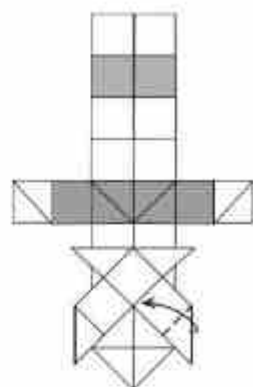

25. 按照峰谷折上去并局部放大

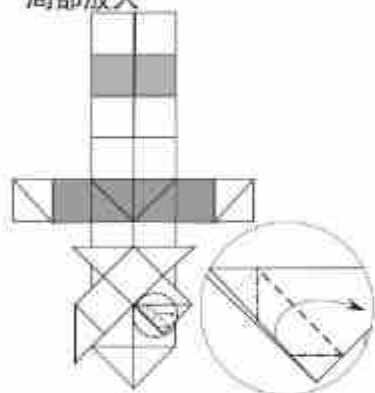

26. 按照峰谷线折叠

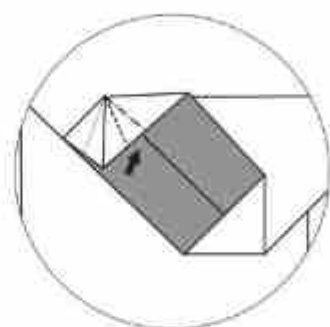

27. 按照峰谷线折叠

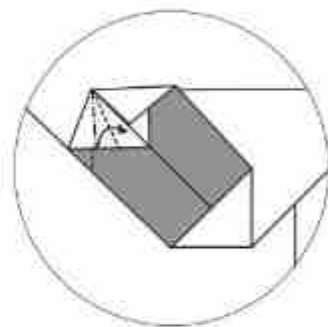

28. 完成后恢复正常大小

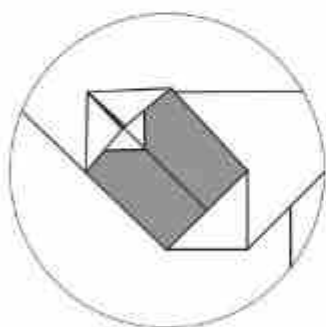

29. 左侧重复24-28步

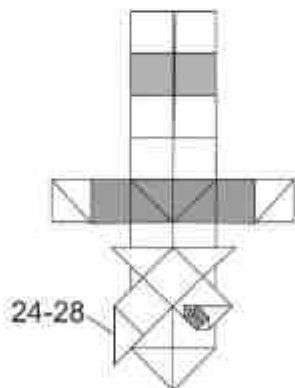

30. 局部放大

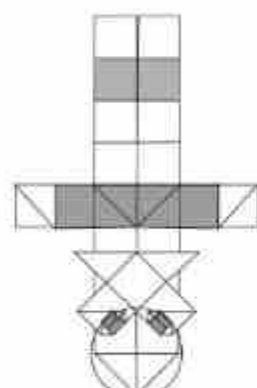

31. 接下来脸部有两套整形方案，A偏写实B偏卡通，大家可自由选择

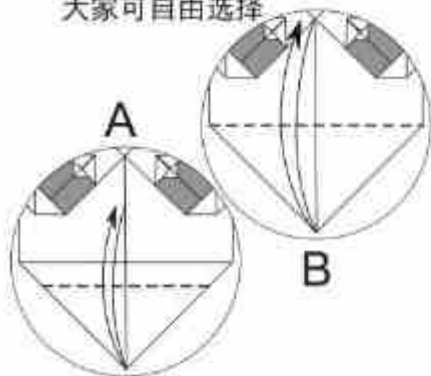

32. 此步为完成图可根据喜好选择

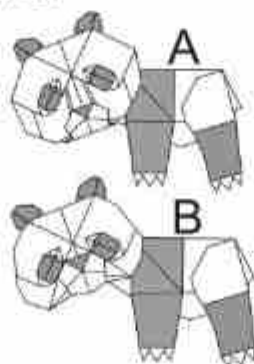

33. 按照峰谷线折叠

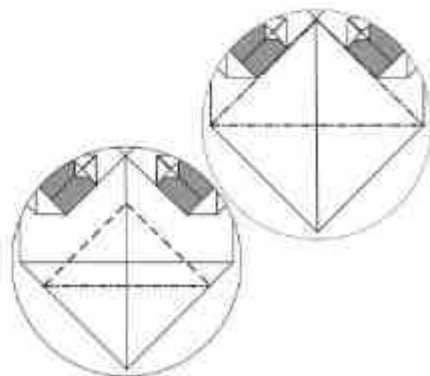

34.折角平分线

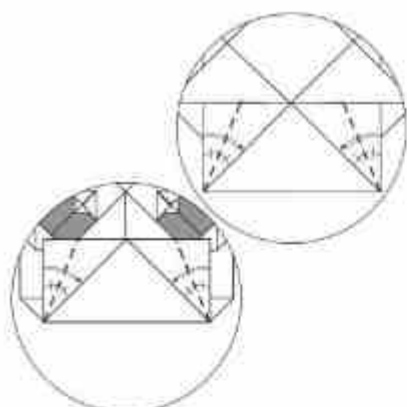

37.接下来身体以A整形为例,AB身体相同

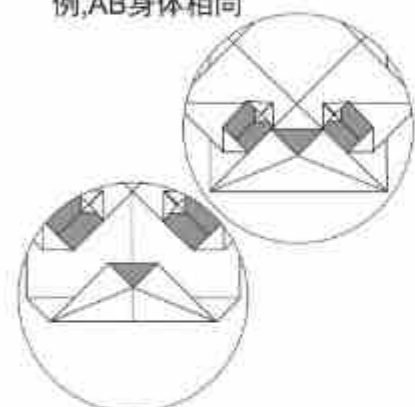

40.将1格的分支向上翻

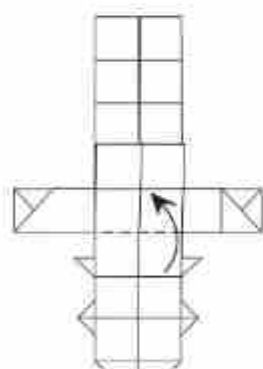

43.按峰谷线折出爪子

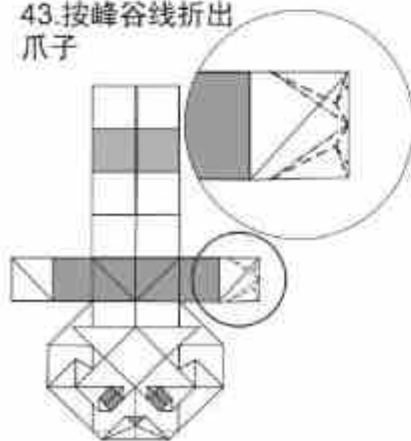

35.按照峰谷线折叠

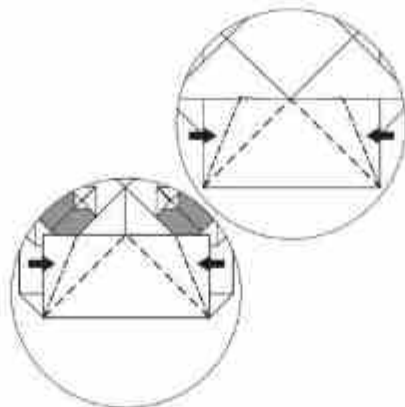

38.翻到背面

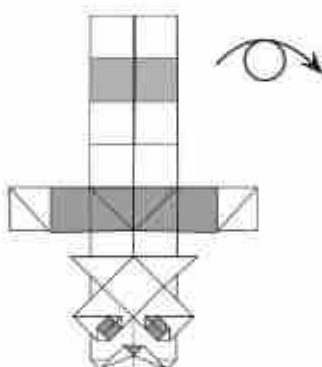

41.将里面部分拉出来,相当于cp中阴影部分拉出来

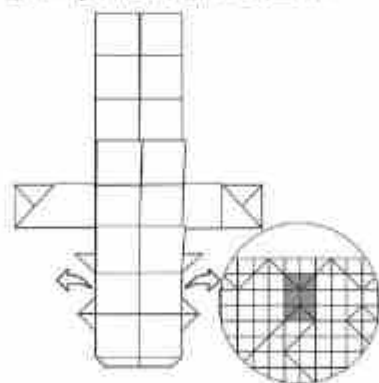

44.按峰谷线段折

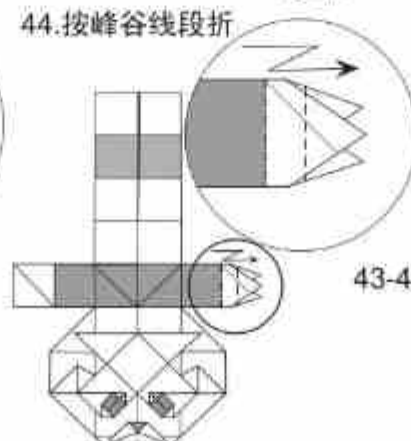

36.按照谷线折下来

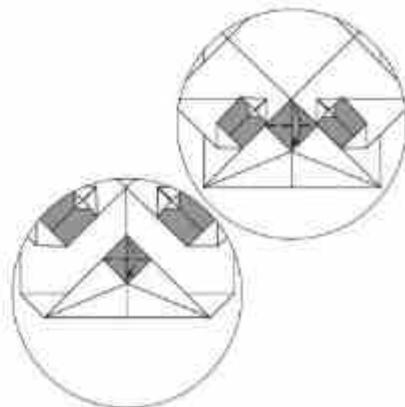

39.将2格的分支向上翻

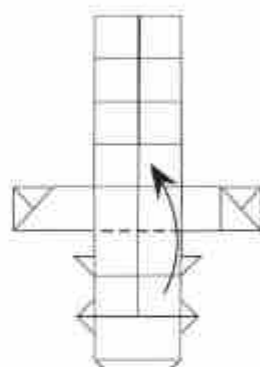

42.回到正面

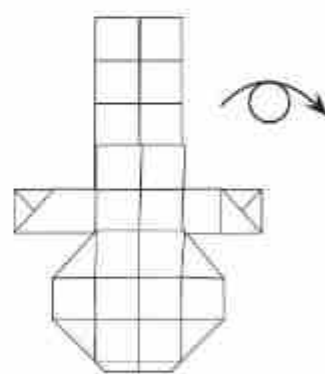

45.其他三个爪子重复43-45步

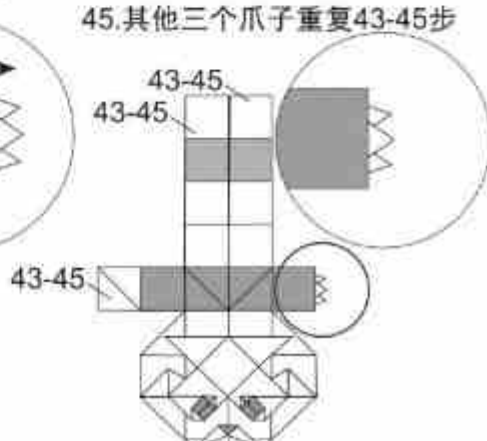

46.按照峰线翻到后面去

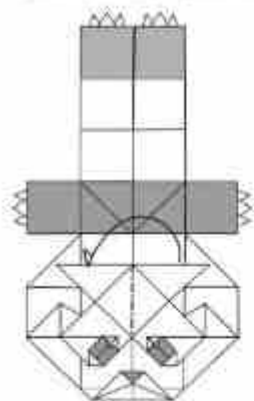

47.按照峰线段折到后面去

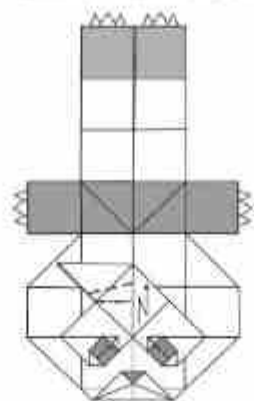

48.按照峰线压下去

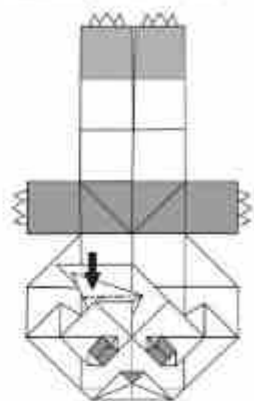

49.耳朵透视并放大

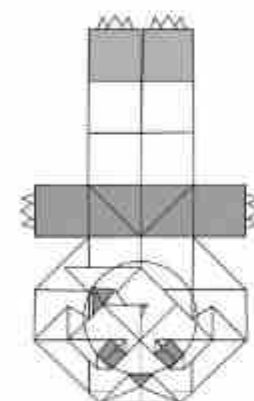

50.按照峰谷线折叠

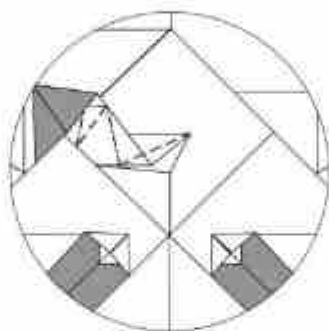

51.翻到后面漏出黑色

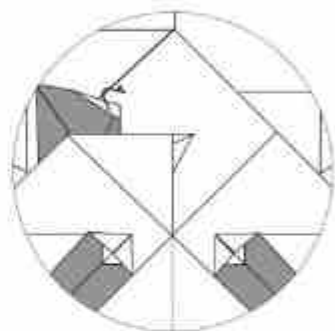

52.按照峰线折到后面去

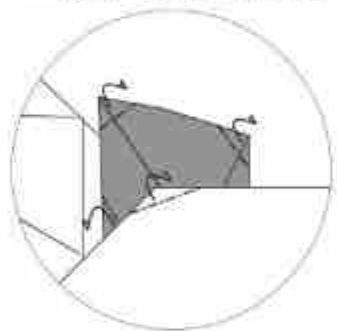

53.完成后回到正常大小

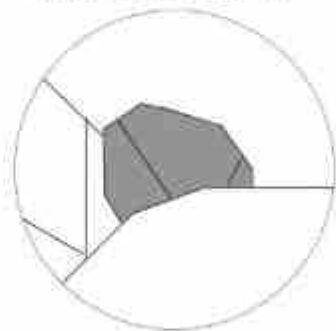

54.另一侧耳朵重复46-53步

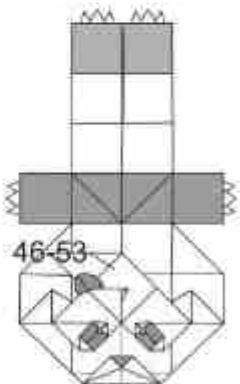

55.按照峰谷几个地方同时进行折叠，并顺时针旋转90°

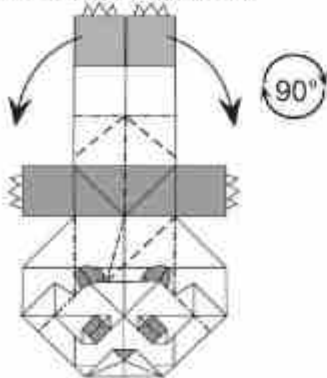

56.按峰线将两边往后翻

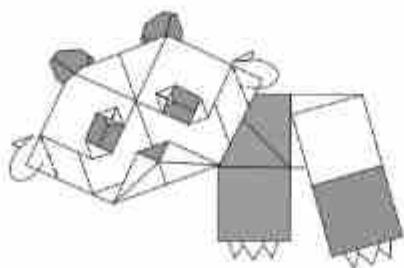

57.沉折进去，另一侧相同

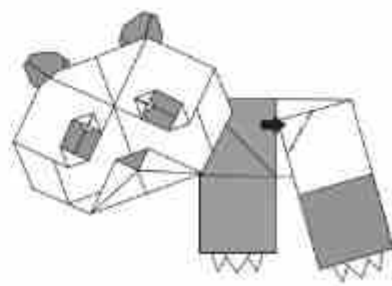

58. 肚子上的2格分支拉出来
做肚皮

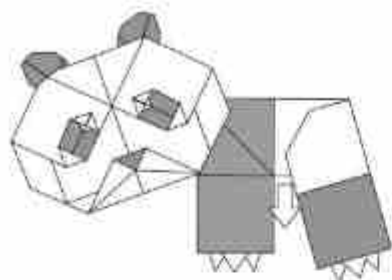

59. 肚子透视，按峰线折进去，另一侧相同

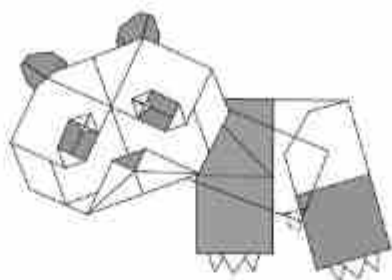

60. 尾巴透视的纸层拉出来一
层的一部分

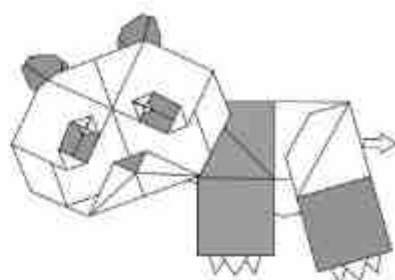

61. 按照谷线折叠，眼睛局部
放大

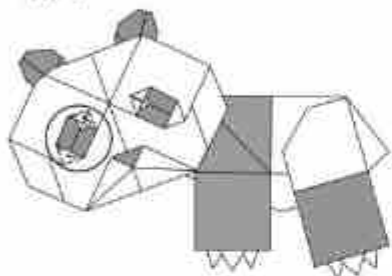

62. 按照峰线折到后面去

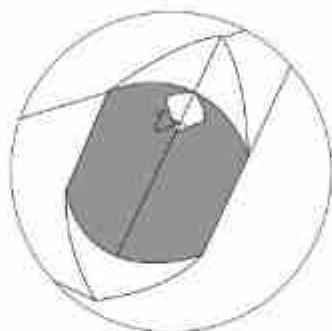

63. 另一侧眼睛重复61-63步

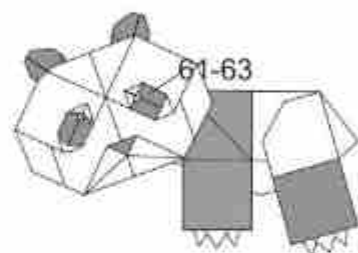

64. 按照峰谷线完成整形

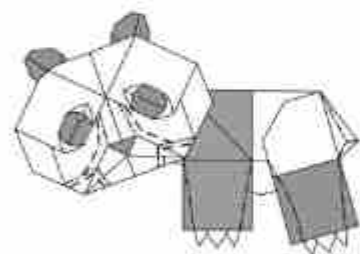

65. 整形A完成!

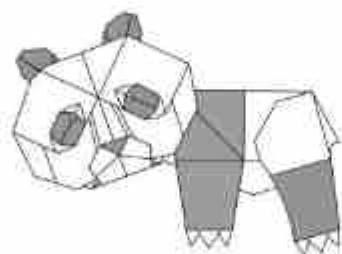

66. 继续整形B

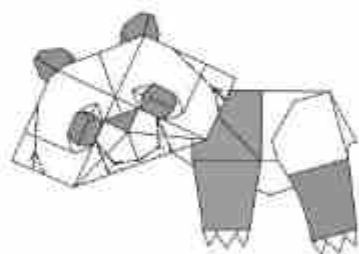

67. 完成!

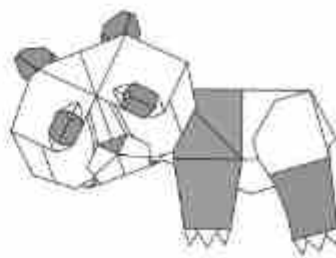
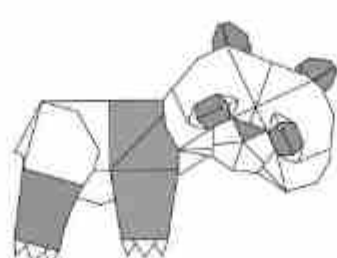
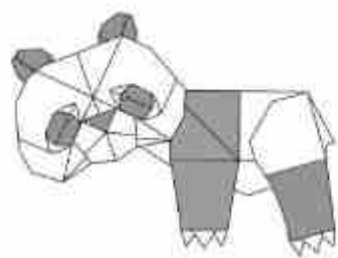

Skunk

Intermediate

Gareth Louis

©2021 - Australia

Start with a 25cm square of black/white kami or tissue foil.

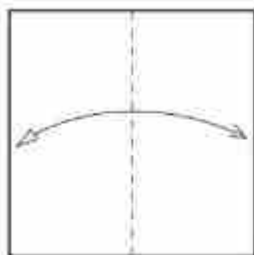

1. White side up.
Precrease

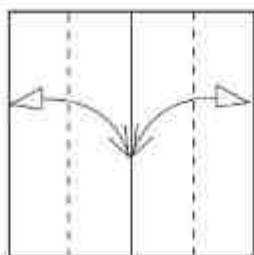

2. Precrease to the centre.

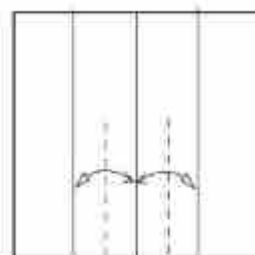

3. Precrease halfway.

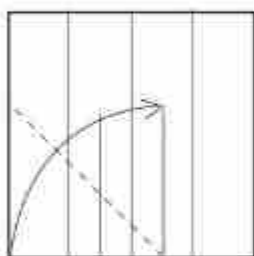

4. Valley diagonally to
the step 3 crease.

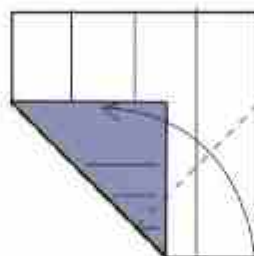

5. Valley

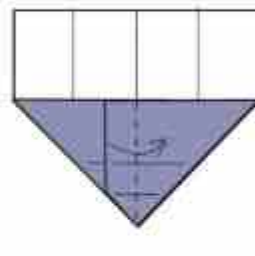

6. Valley to the right.

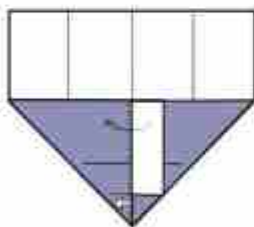

7. Valley over while pulling
a hidden flap to surface.

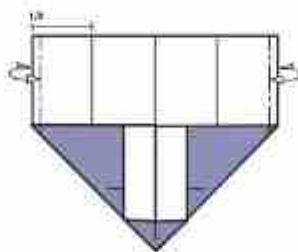

8. Precrease with a
mountain fold. The
crease is 1/8th of
the quarter.

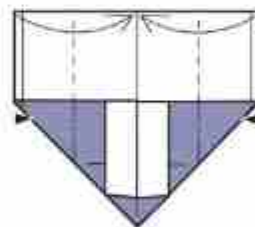

9. Valley to the centre
whilst reversing in.

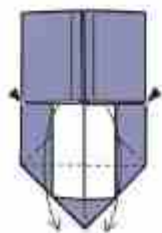

10. Swing flaps down
while squashing the
corners.

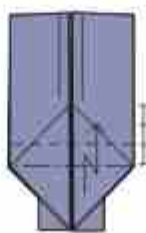

11. Pleat along the
indicated thirds.

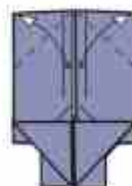

12. Precrease. Next drawing
is larger.

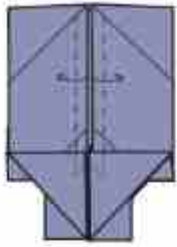

13. Valley along the existing creases whilst squash folding the hidden corners to create a hem.

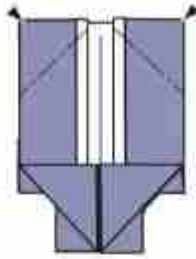

14. Reverse fold inside.

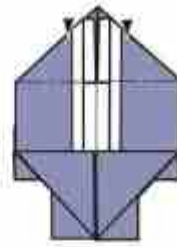

15. Reverse inside taking the hems with it.

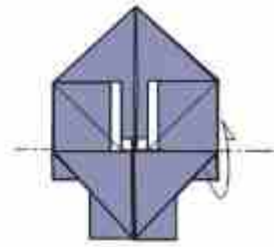

16. Mountain the bottom edge.

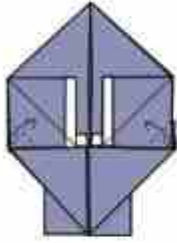

17. Precrease diagonally. Note the folds end at the corner of the folded edge.

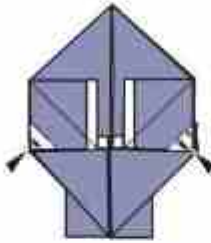

18. Reverse fold the shaded areas.

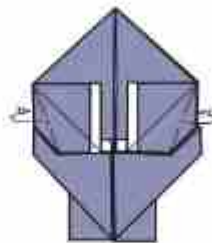

19. Mountain behind.

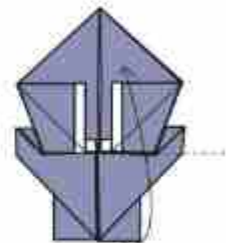

20. Swing a flap up.



21. Swing the flap to the left.

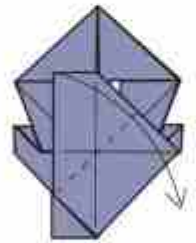

22. Valley diagonally.

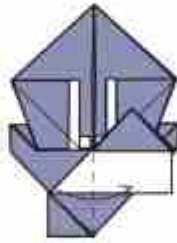

23. Valley.

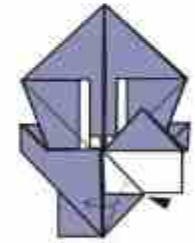

24. Squash along angle bisectors.

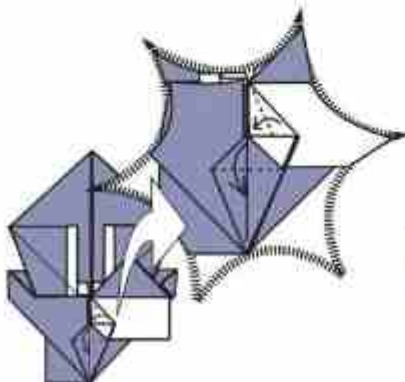

25. Swivel down.

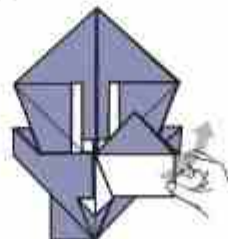

26. Hold indicated area and pull up to release a hidden area. The paper will not lie flat.

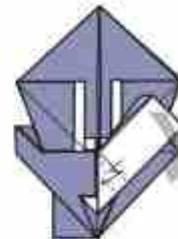

27. Refold back while inserting a pleat, thereby flattening the model. Next drawing is larger.

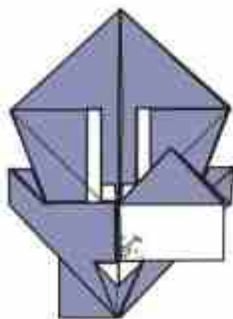

28. Precrease diagonally. Note where the fold terminates.

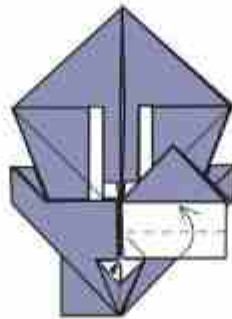

29. Fold up whilst incorporating a squash. Try to hit the coloured edges as you perform this.

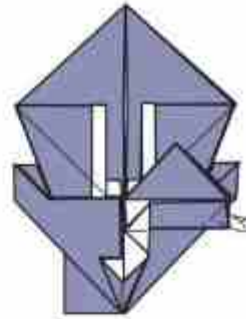

30. Mountain behind.

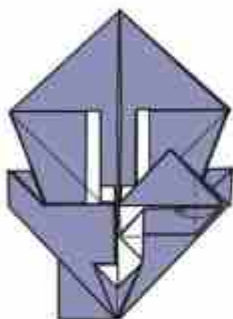

31. Valley all layers.

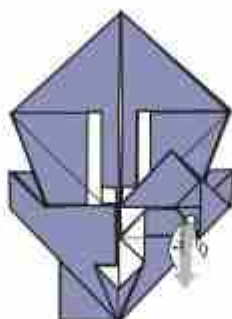

32. Grab the layer and pulldown to expose a spiky point.

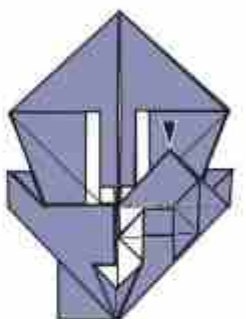

33. Reverse inside.



34. Valley noting the connecting points while pulling the spiky point out.

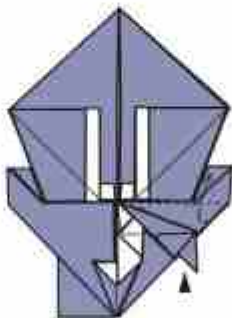

35. Swing hidden flap while reversing material. See next step on where this lands.

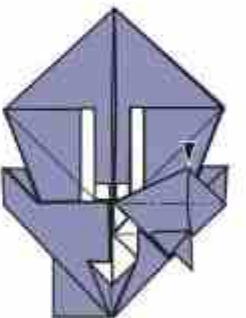

36. Reverse inside.

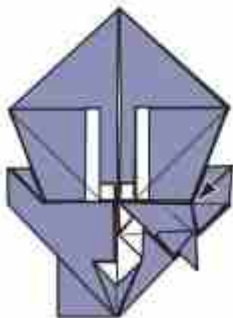

37. Reverse but ensure the point does not go into the pocket.

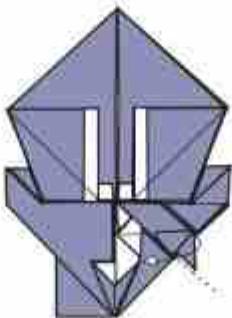

38. Unfold a flap with a soft fold.

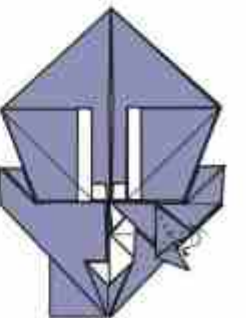

39. Close back flap while inserting a reverse fold along angle bisectors.

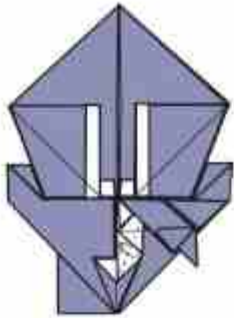

40. Small valley fold.

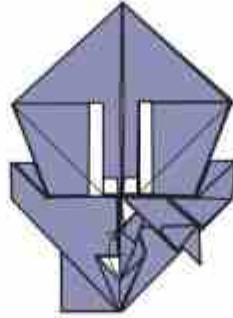

41. Swing the small flap up.

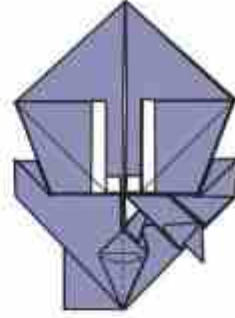

42. Swing to the right.

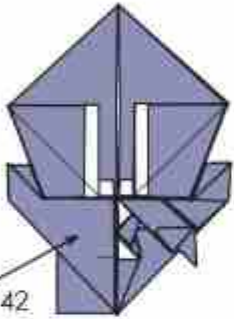

20 - 42

43. Repeat steps 20-42 in mirror image on the left side.

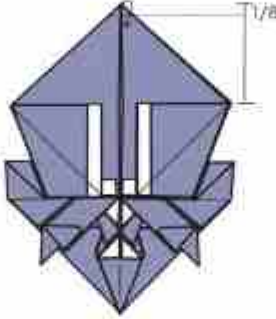

44. Make a small valley fold $1/8$ th of the region.

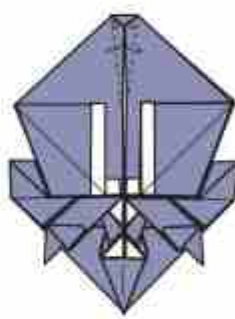

45. Valley fold tiny hems while ejecting hidden material.



46. Wrap a single layer behind. You will need to open the flaps to do this.

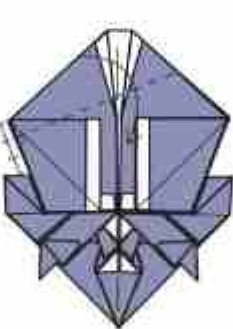

47. Valley. Note indication where the fold connects and see next drawing for positioning.

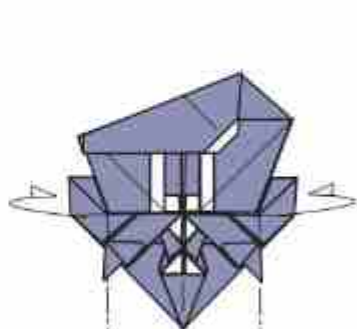

48. Mountain excess flaps behind.



49. Mountain behind along angle bisectors.

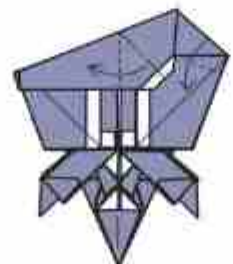

50. Valley to the left while swiveling to match the orientation on the left.

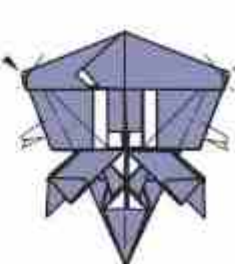

51. Mountain behind while squashing the corners.

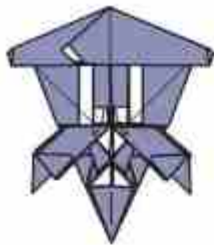

52. Valley the tiny hems to hide the white. The fold starts at the hidden corners.

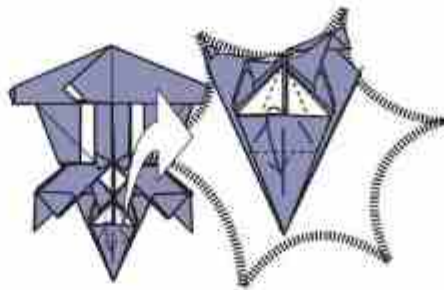

53. Petal fold down. Offset the folds a little so it gives of a white gap.

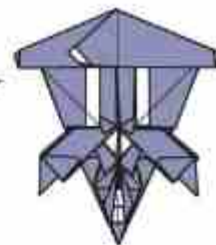

54. Rotate 90° clockwise.

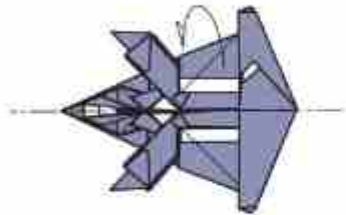

55. Mountain fold in half. Make this fold a soft one.

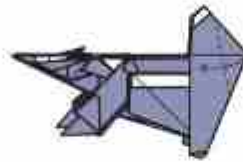

56. Valley. See positioning of where the fold starts.

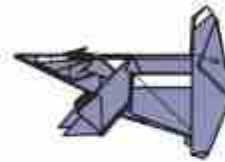

57. Bring the layer beneath to surface thereby close sinking the flap.

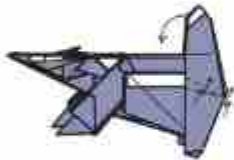

58. Crimp the tail into position.

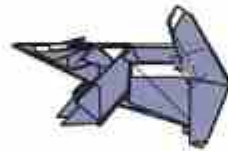

59. Narrow the tail on both sides with swivel folds.

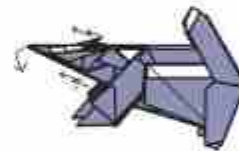

60. Crimp the head.

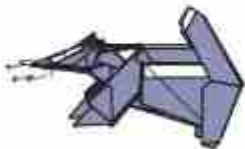

61. Pleat to form mouth.



62. Final shaping of the body. Open the tail halfway to add some volume to it. Open ears.



63. Completed Skunk.
© Gareth Louis July 2021

Shirley Star

Jonicley Macedo

©2020 - Brazil

Low Intermediate

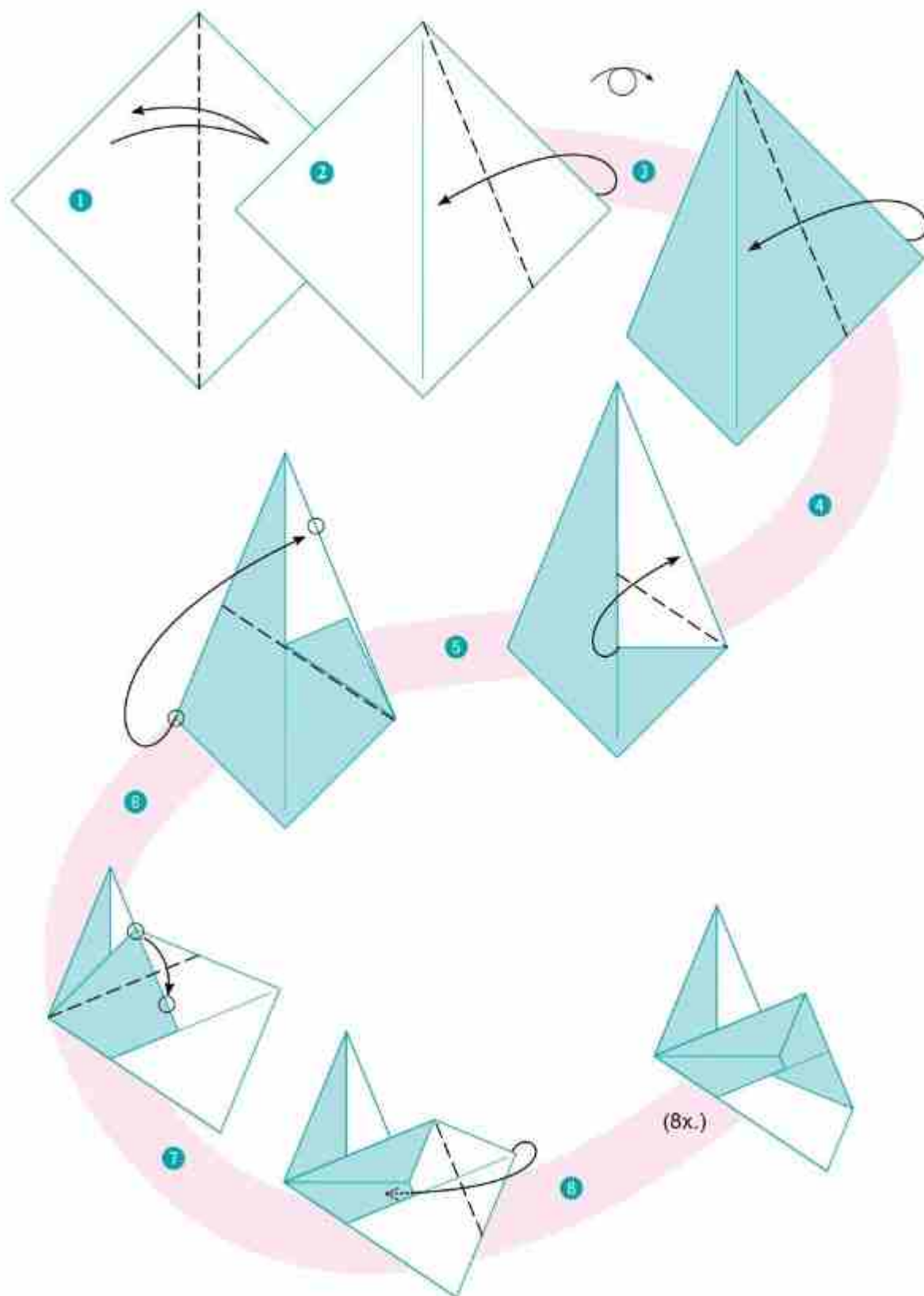

Assembly:

1

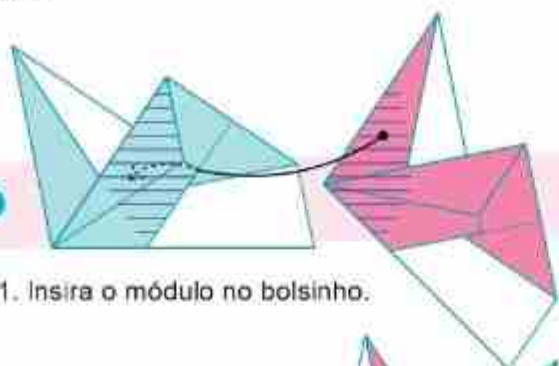

1. Insira o módulo no bolsinho.

2

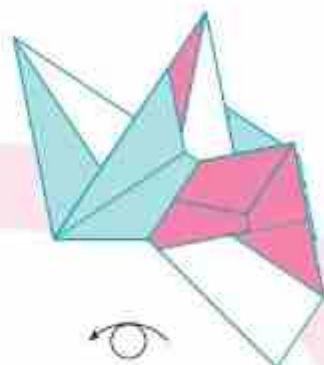

5

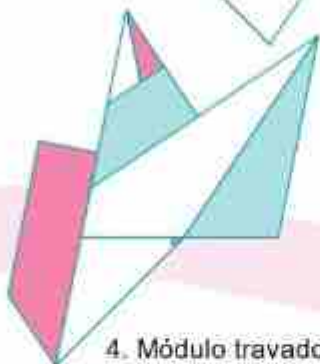

4. Módulo travado.

4

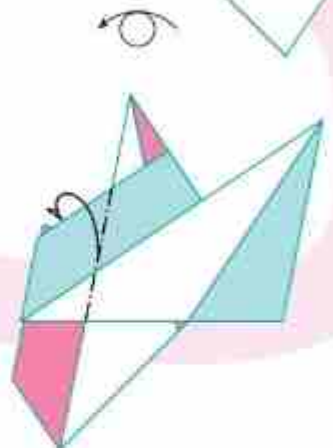

3

3. Dobre a aba do módulo em montanha, travando o modelo.

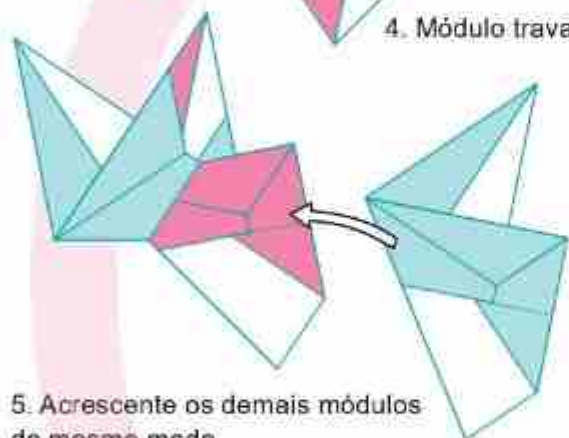

5. Acrescente os demais módulos do mesmo modo.

6

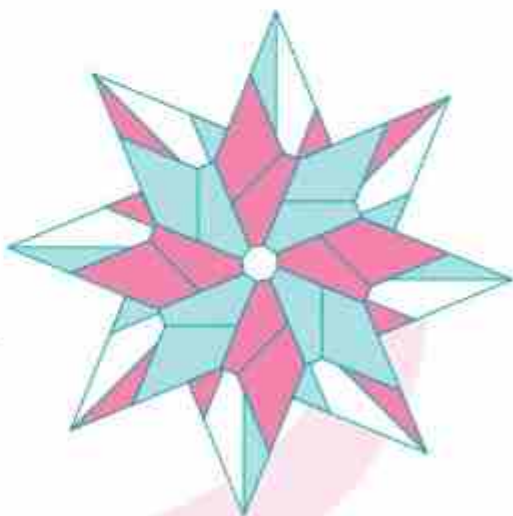
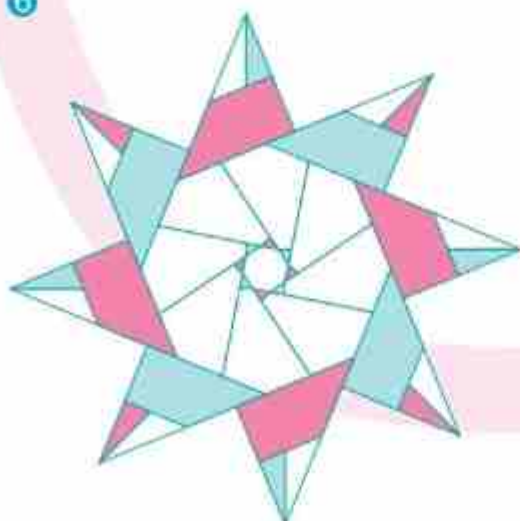

7

Rainbow Island Penguins

Adriano Mariani

©2021 - Italy

Simple

PAPER:

-KAMI 10-15CM.

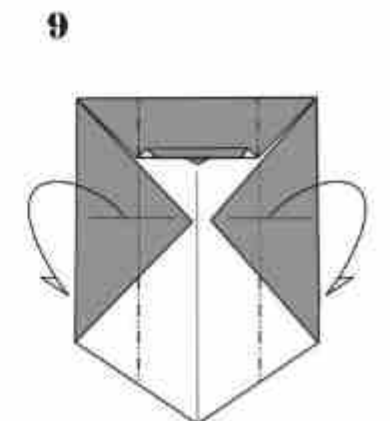
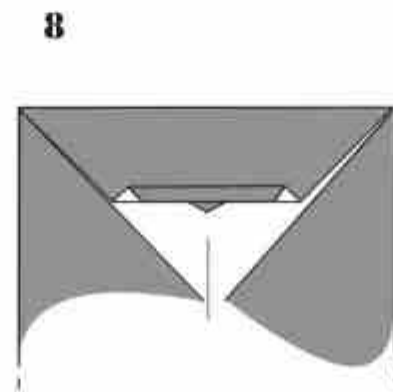
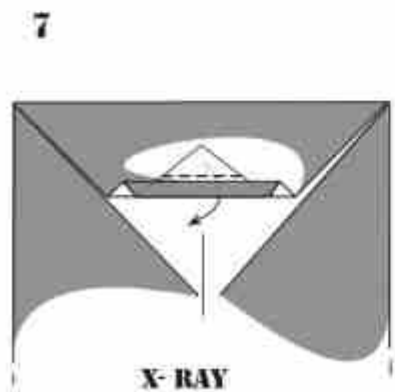
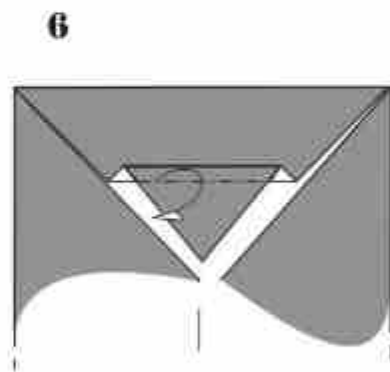
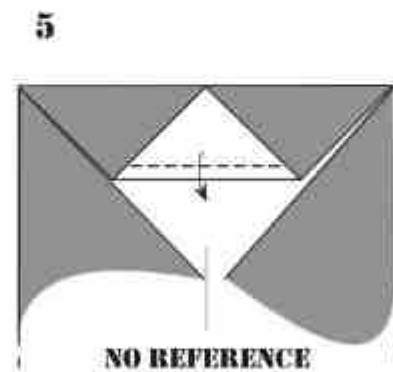
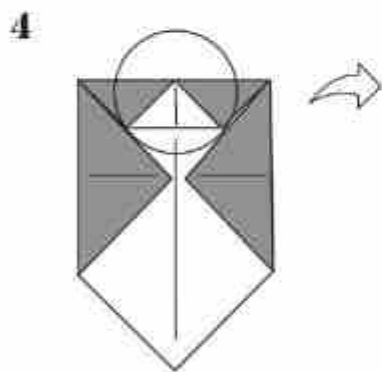
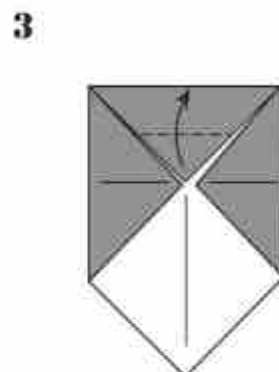
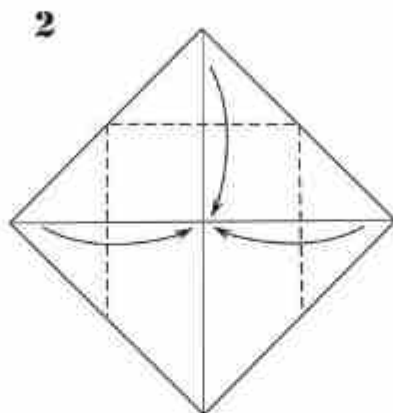
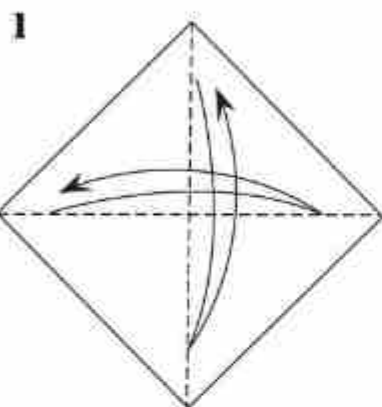
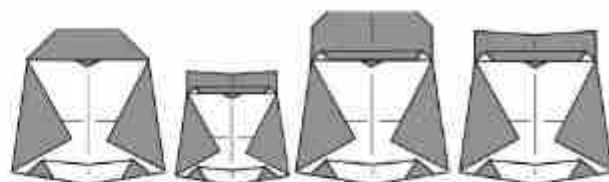

10

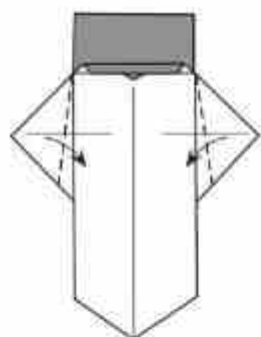

11

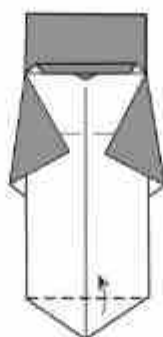

12

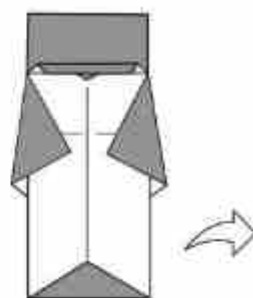

13

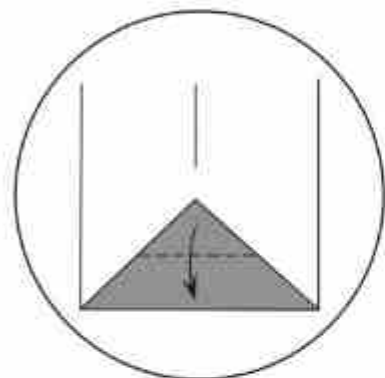

14

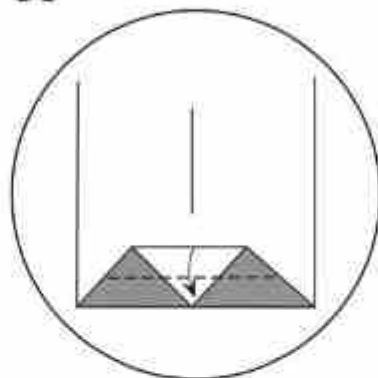

15

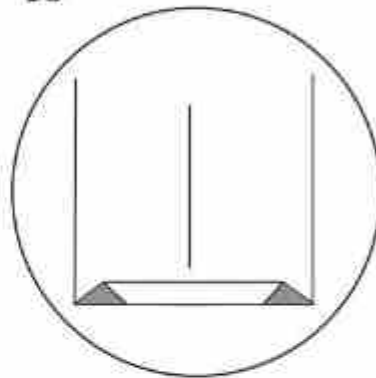

16

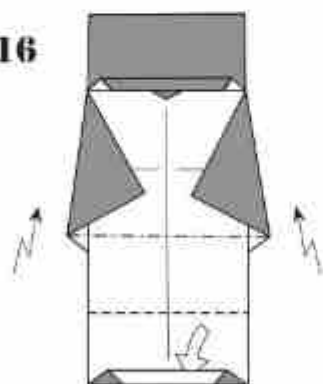

17

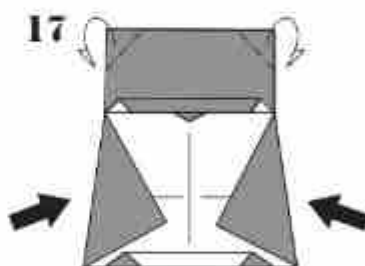

18

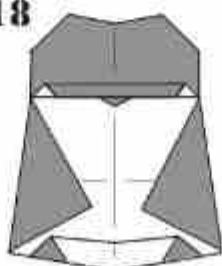

THIS IS PENGUIN N°1

FINITO!!!

OTHER PENGUINS...

N°2



**START FROM STEP N°3
ONLY THE HEAD CHANGES**

1

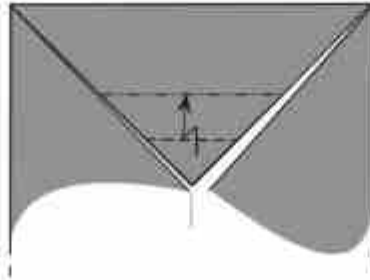

2

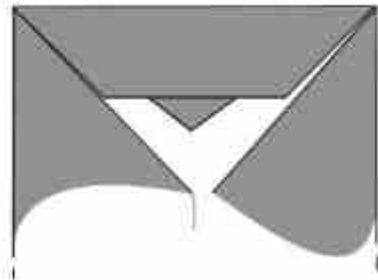

3

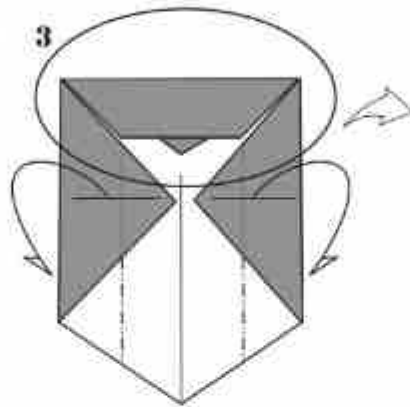

4

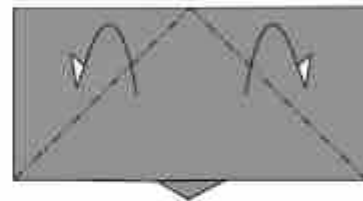

5

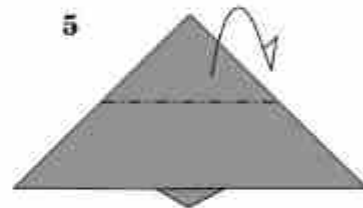

N°3

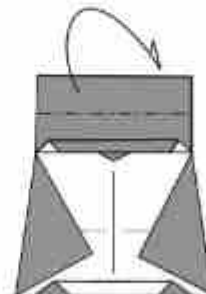
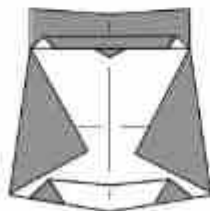

START FROM STEP N°17

**FOR PENGUIN N°4 I USE A SMALLER SHEET.
CHOOSE ONE OF THEM! FIND YOUR WAY.**

Onibi Star

Low Intermediate

Linda Marlina
Hadi Tahir (dgrms.)
©2021 - Indonesia

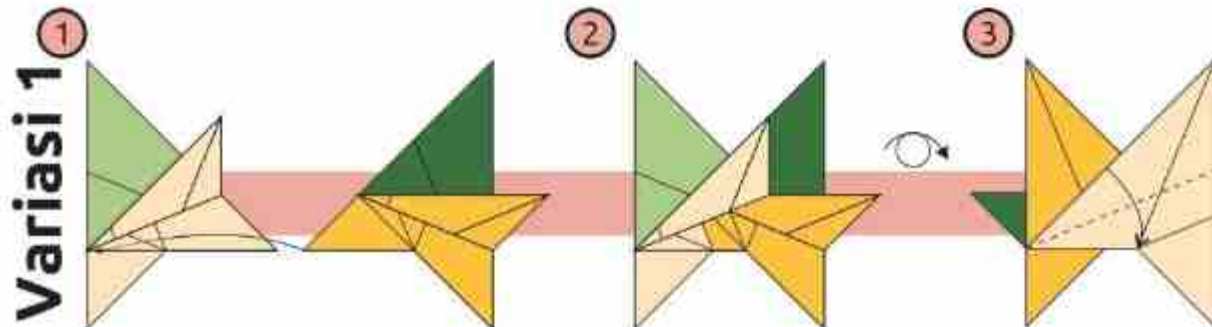
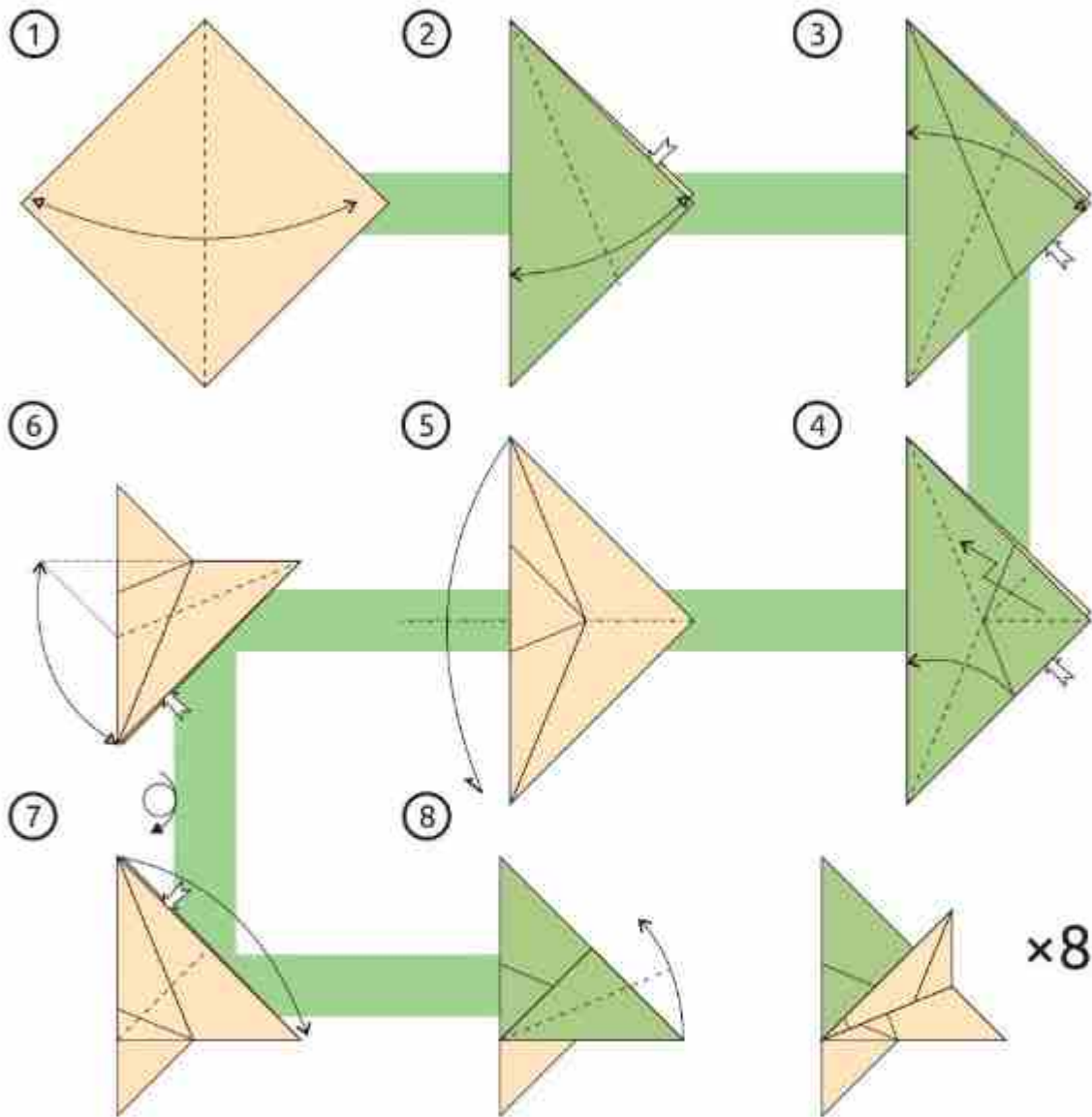

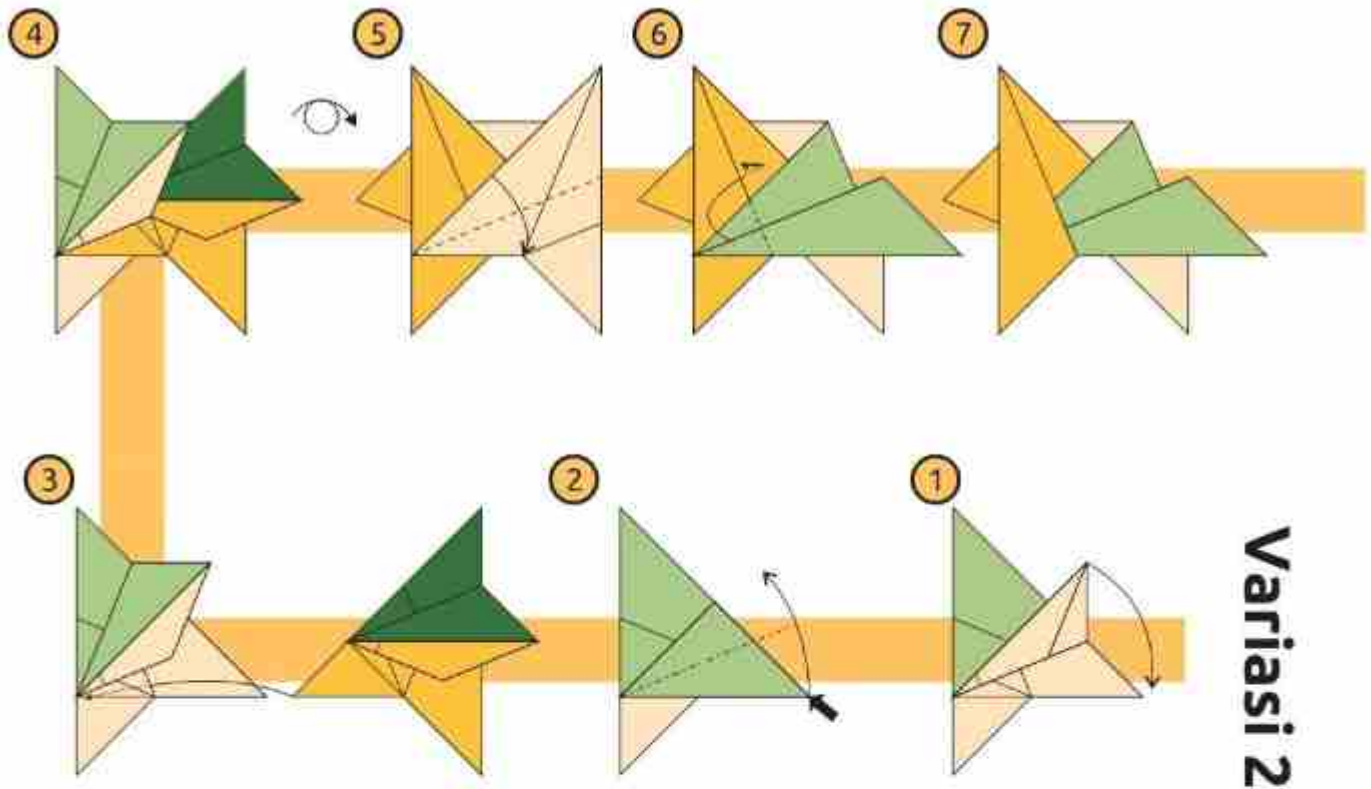

Variasi 2

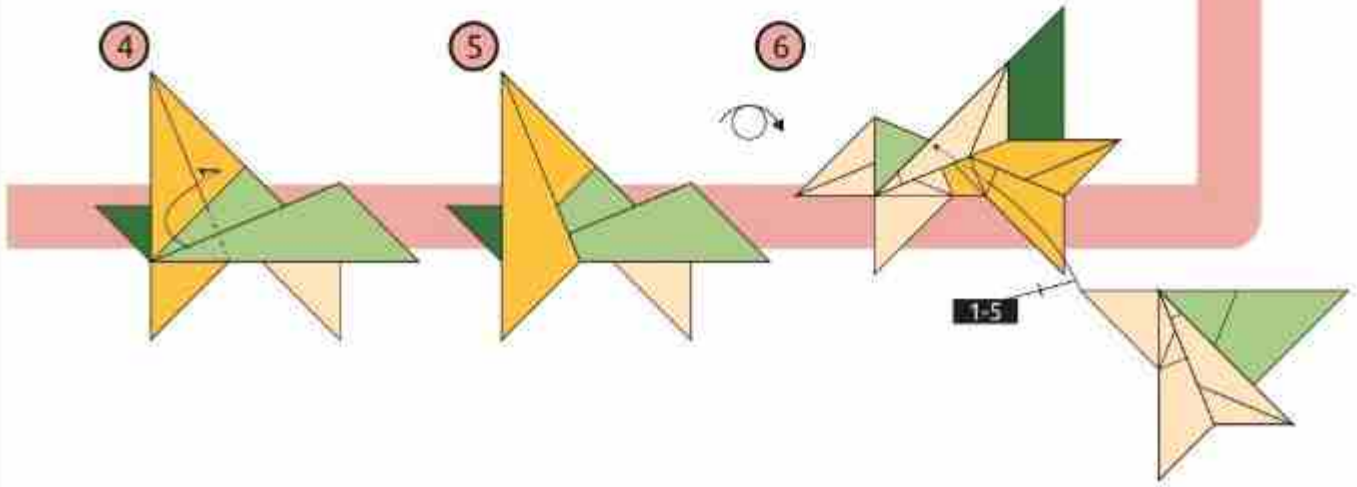
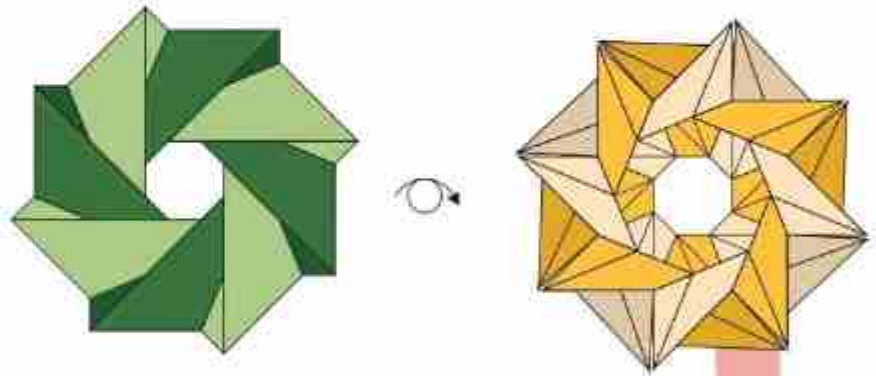

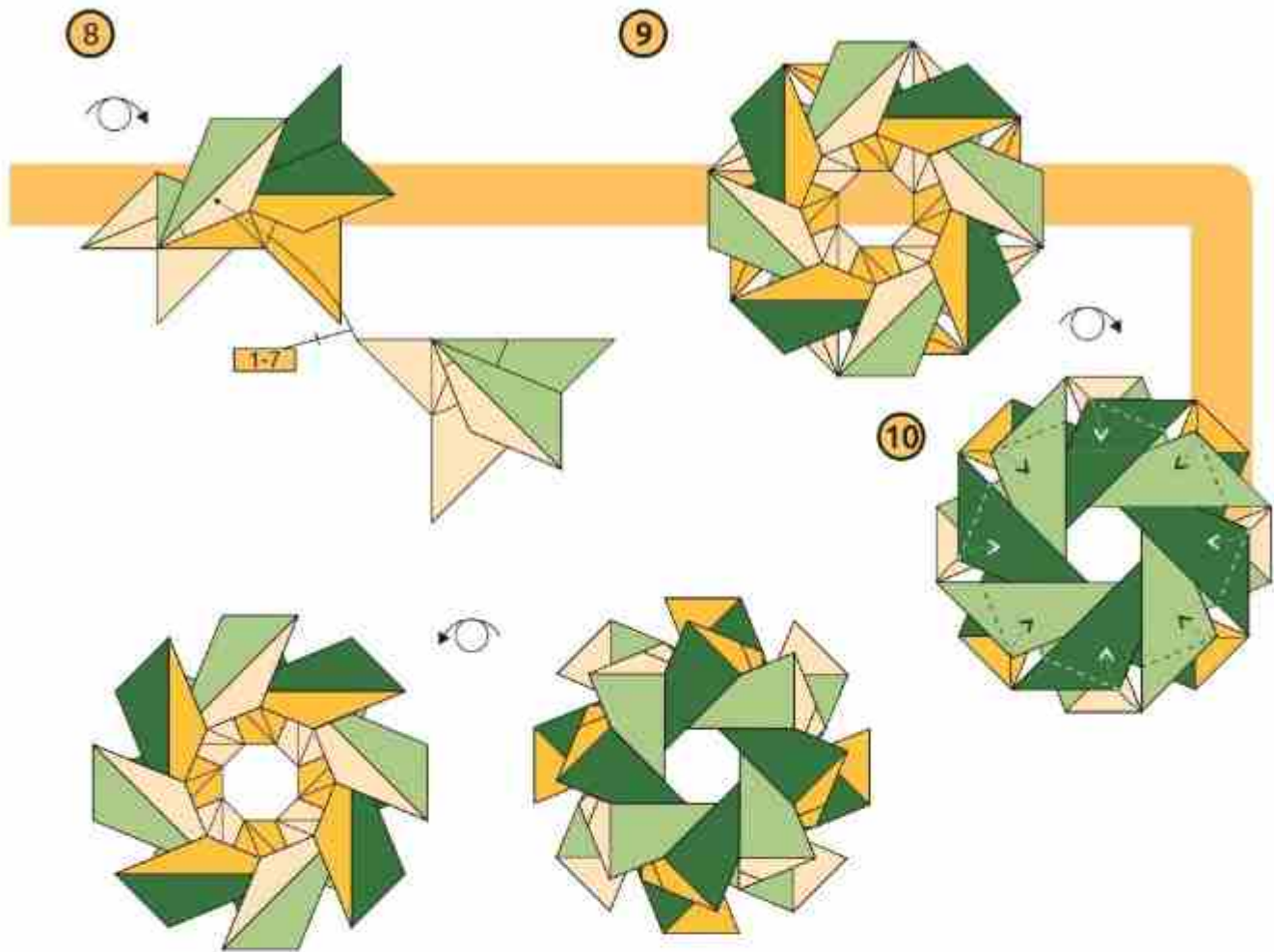

Variasi 3

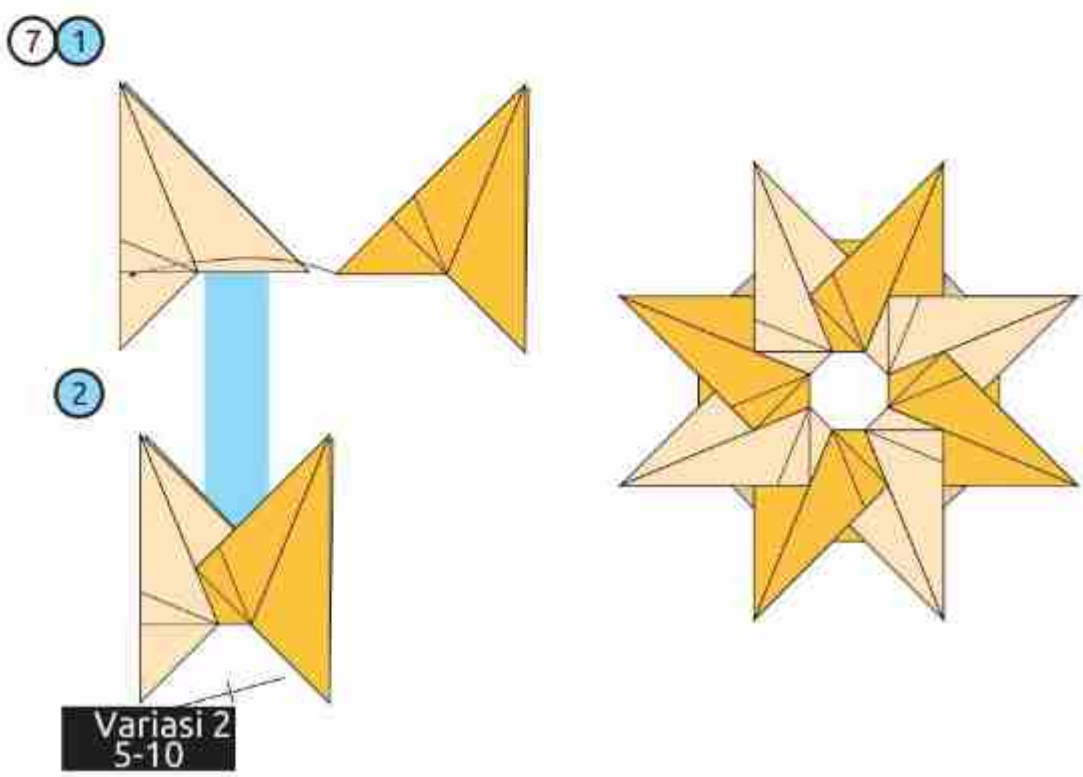

Variasi 2
5-10

Variasi 5

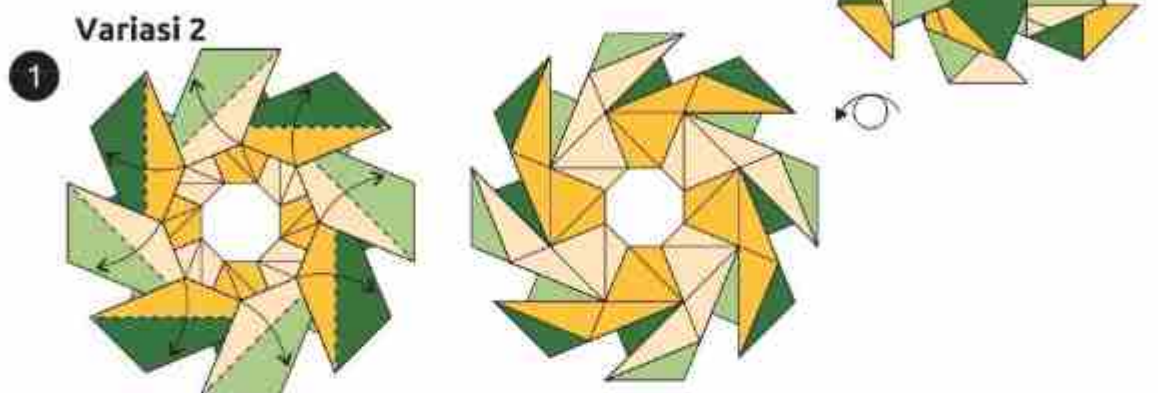

Variasi 4

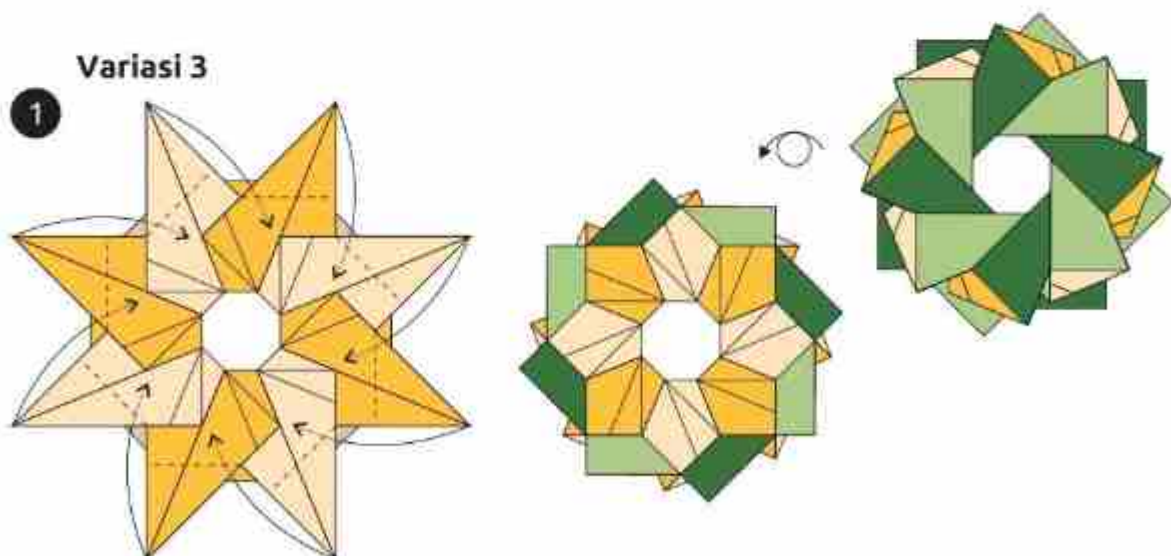

Monika 8-Pointed Star

Yossi Nir

©2023 - Israel

Intermediate

Paper :8 squares 15x15 cm Kami paper.

Dual color

Star size : 17.5x17.5 cm

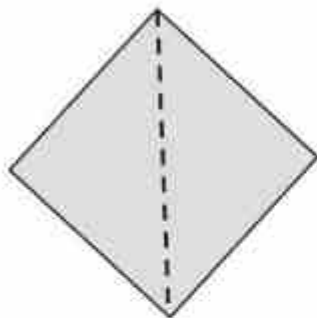

- 1 Color side up.
Valley fold and unfold.

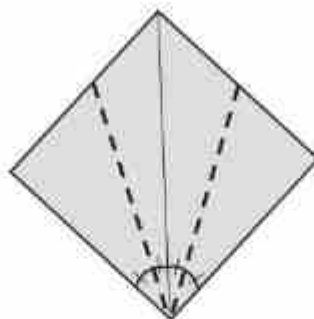

- 2 Valley folds.
Bisector.

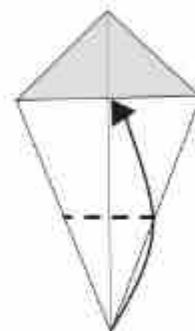

- 3 Valley fold.

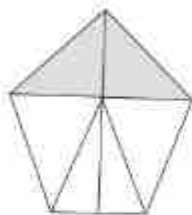

- 4 Unfold the paper.

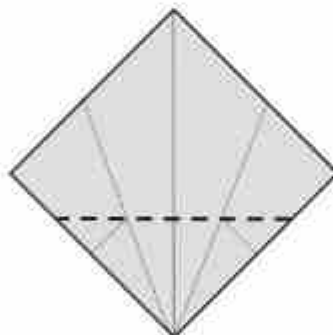

- 5 Continue the existing Valley
fold to both ends and unfold.

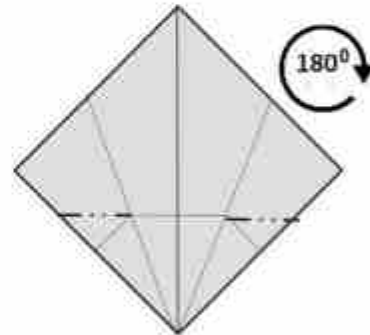

- 6 Convert the marked sections
to mountain folds.

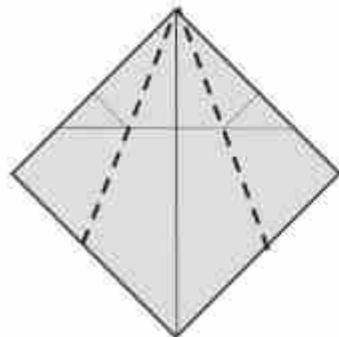

- 7 Valley fold along the creases.

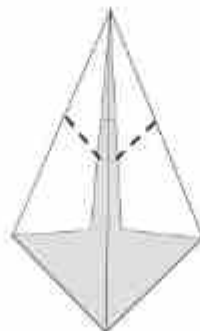

- 8 Use the two existing
valley folds for step 9.

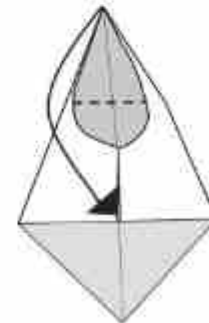

- 9 Make the existing fold.

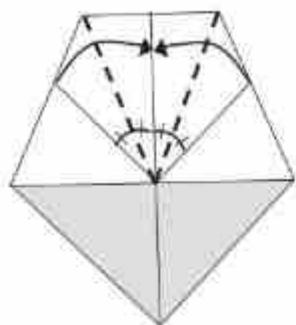

10 Valley folds
Bisector .

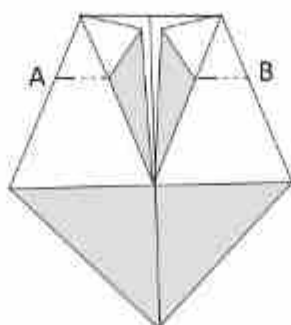

11 Mountain fold from A to B,
But don't make a crease
on the upper triangle .

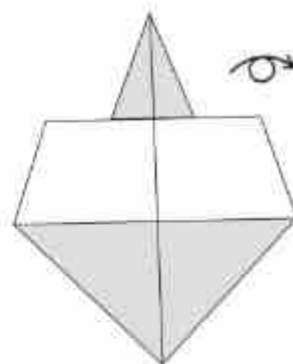

12 Turn over.

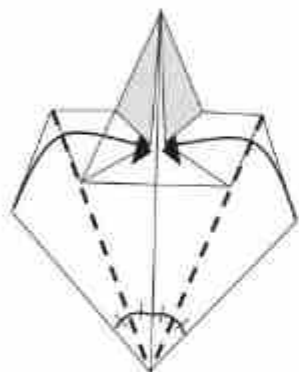

13 Valley folds
Bisector .

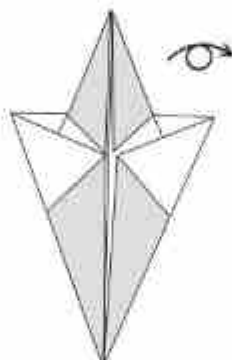

14 Turn over.

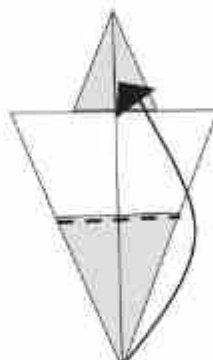

15 Valley fold.

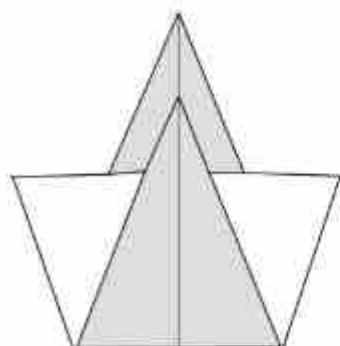

16 Unit completed.
Make 8 units for the assembly.

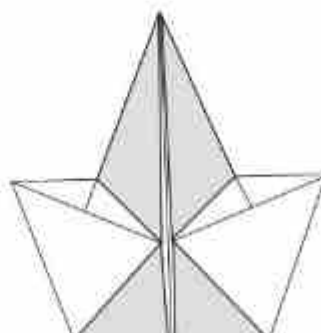

Back side.

Assembly

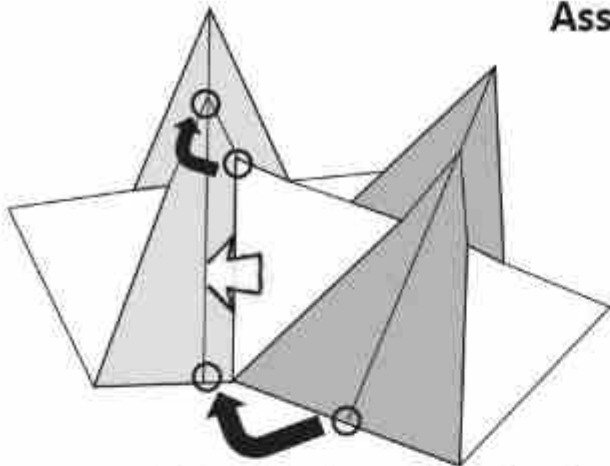

- 1 Put two units one above the other and insert the upper unit into the pocket of the lower unit. Adjust the units to the correct orientation as shown

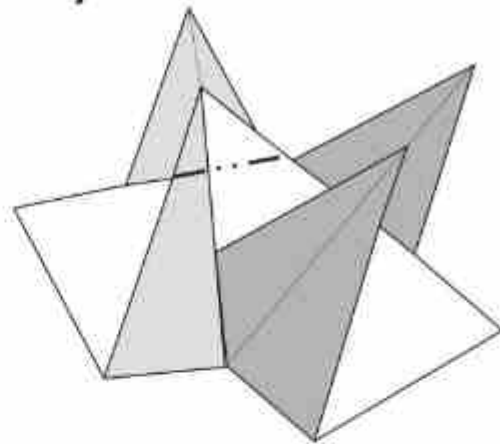

- 2 Mountain fold and insert into the pocket.

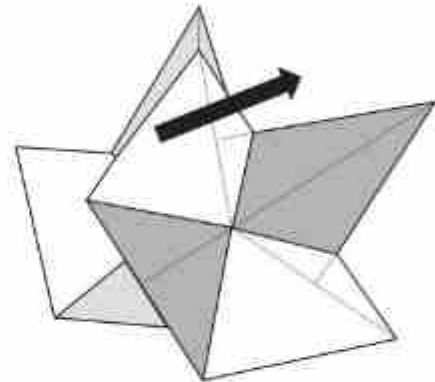

- 4 Lift the upper unit.

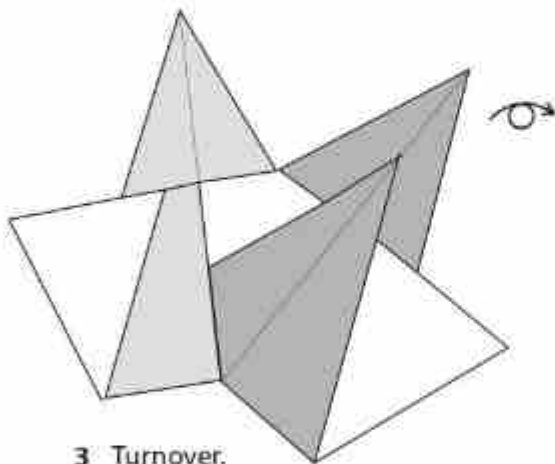

- 3 Turnover.

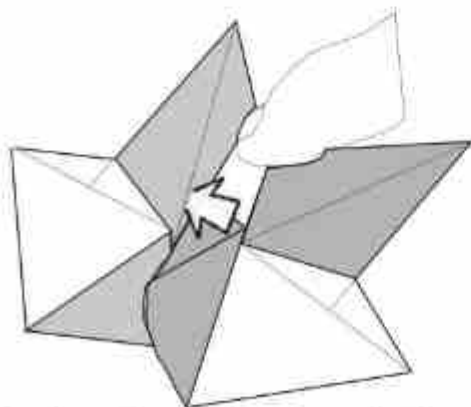

- 5 Insert the flap into the pocket in the lower unit.

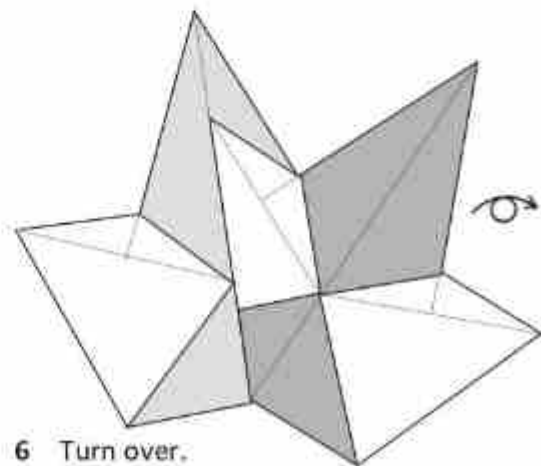

- 6 Turn over.

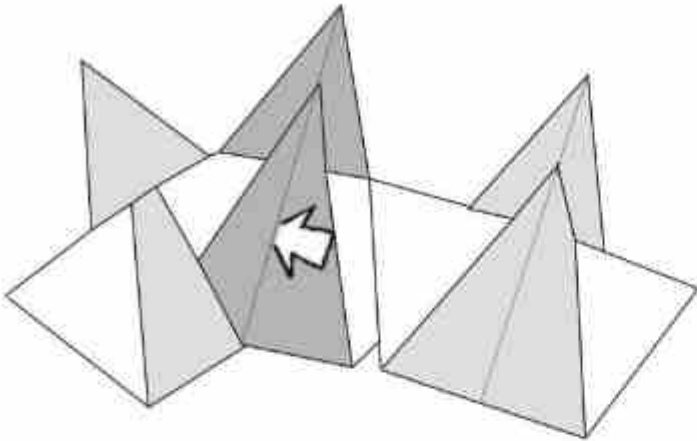

7 Continue to add units to complete the star.

Monika 8 Pointed Star Completed

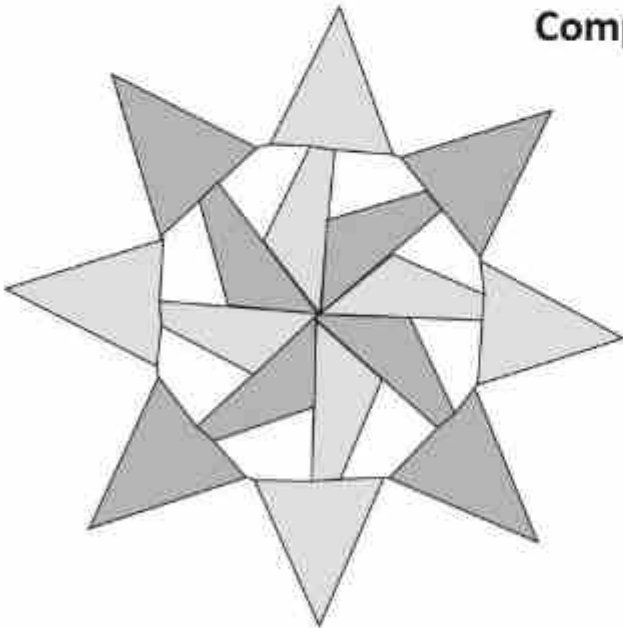

Front Side.

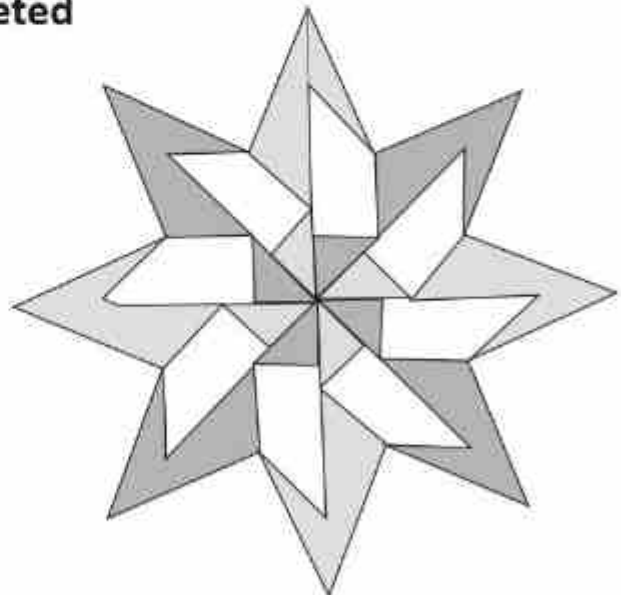

Back Side.

Mariela Star

Maximiliano Ortiz
©2022 - Argentina

Low Intermediate

8 Sheets double sided 7,5x7,5cm.

1.

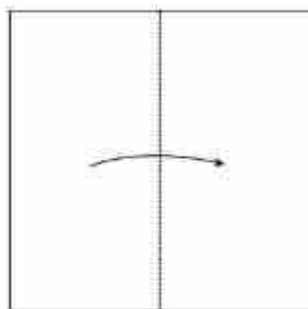

2.



3.



4.

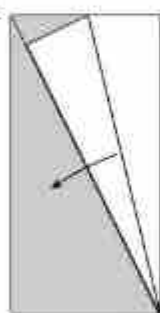

5.

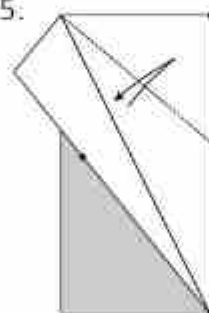

6.

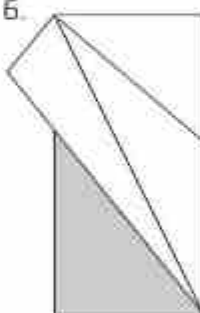

7.

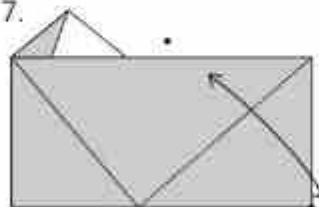

8.

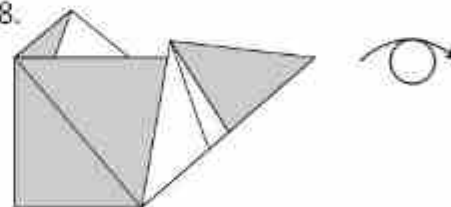

9.

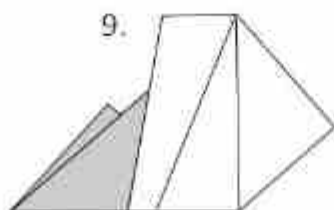

x8

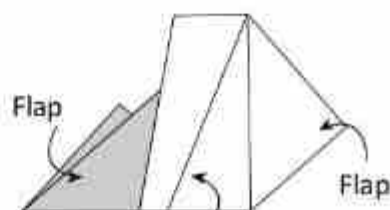

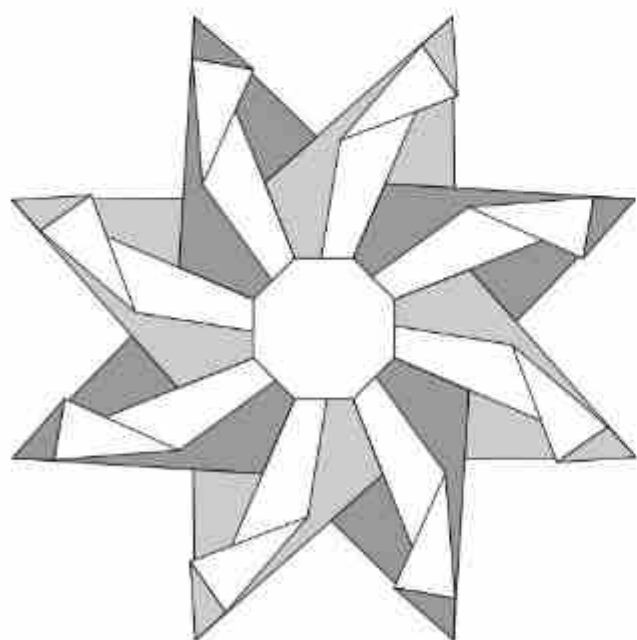
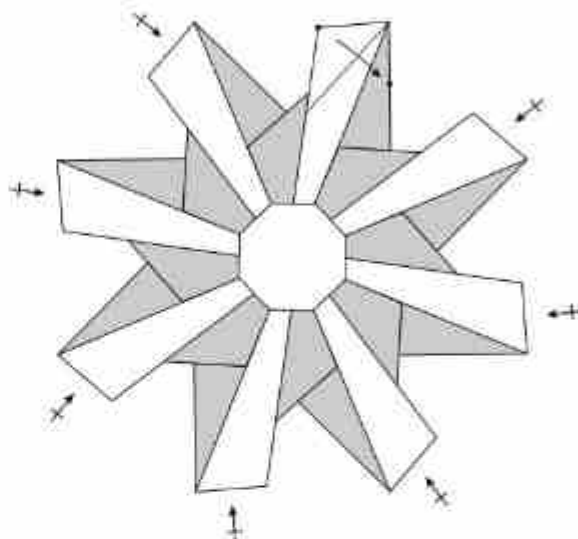
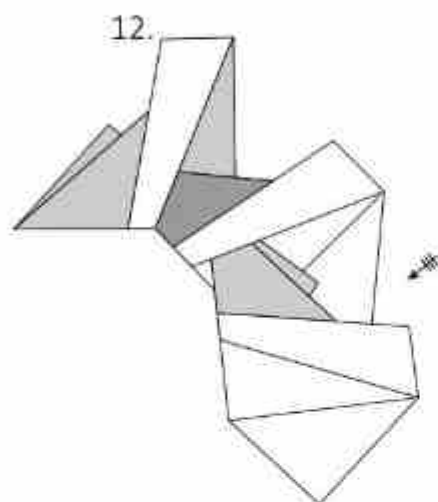
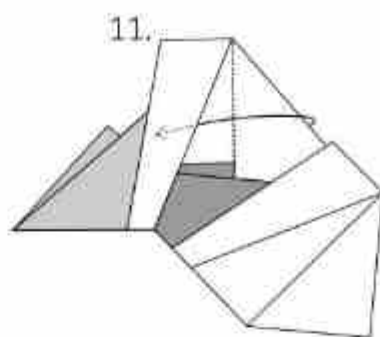
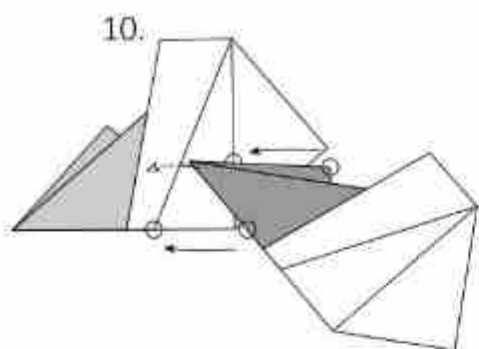

Front

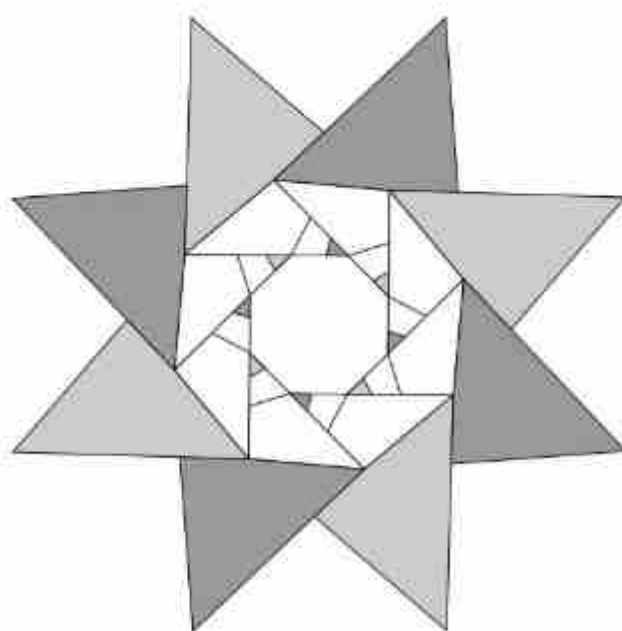

Reverse side

Hashmalon

Yehuda Peled

©2021 - Israel

Intermediate

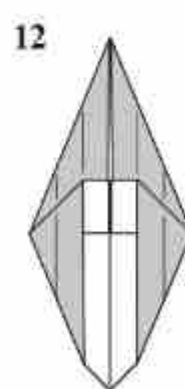
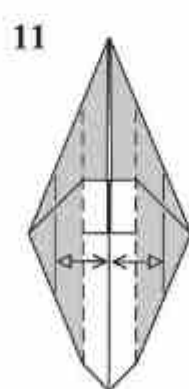
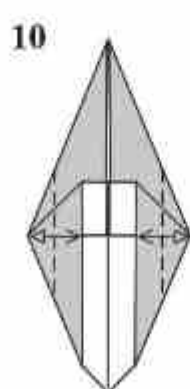
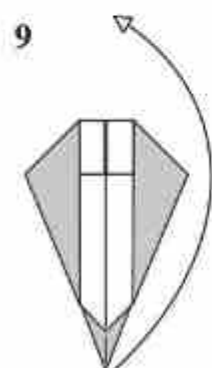
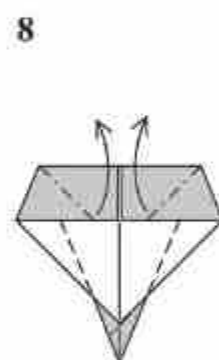
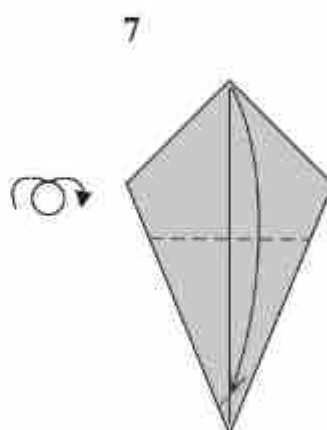
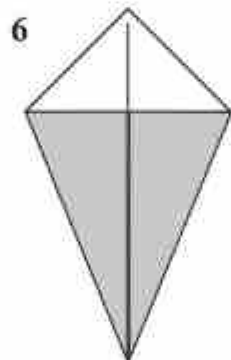
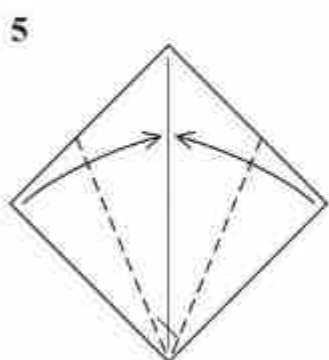
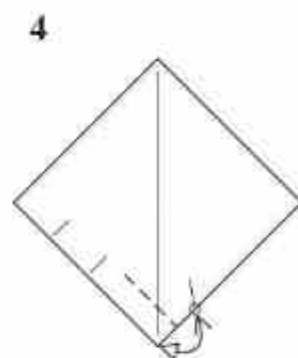
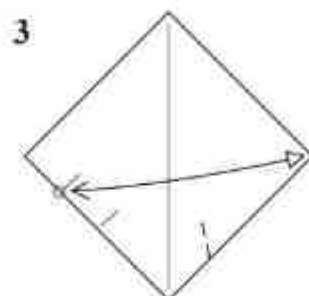
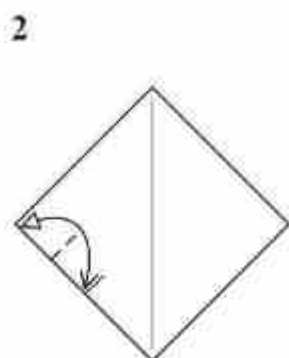
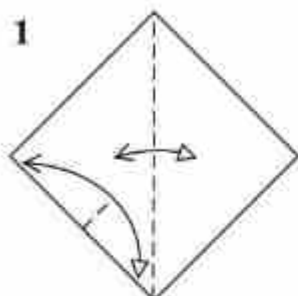

Unfold all.

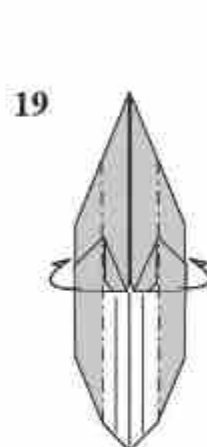
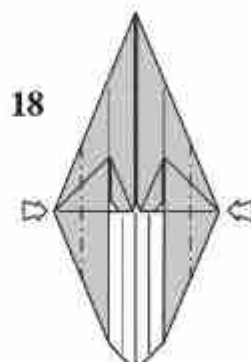
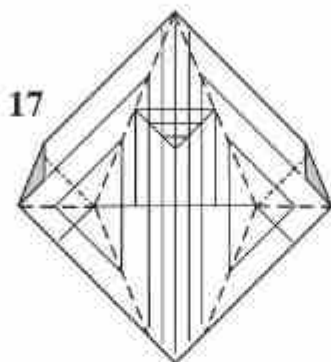
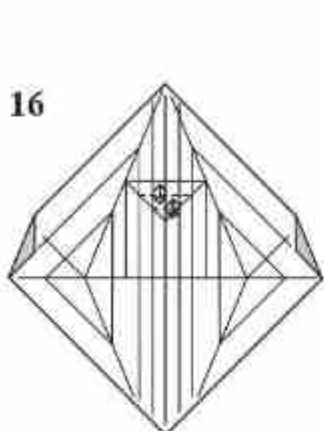
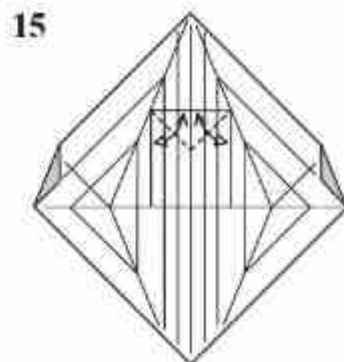
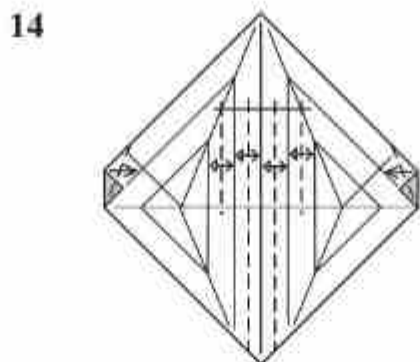
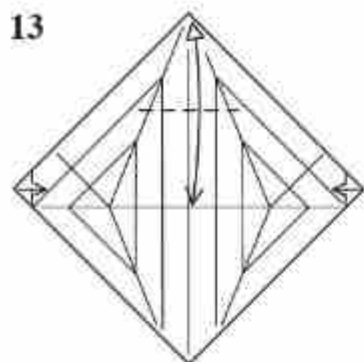

Fold rabbit ears.

Sink.

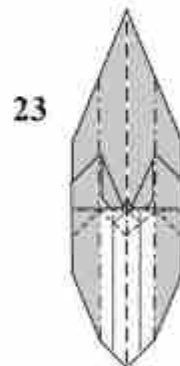
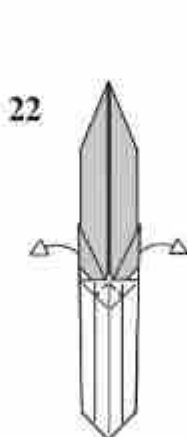
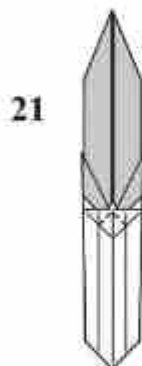
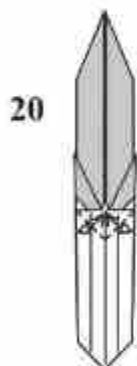

Bisector through all layers.

Fold only the upper layer.

Use the existing creases.

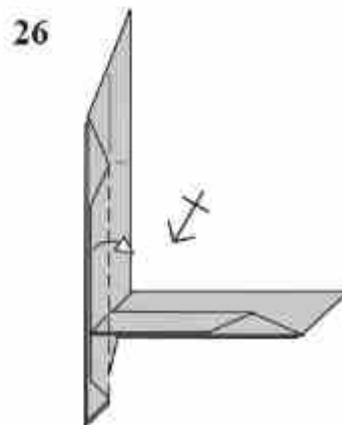
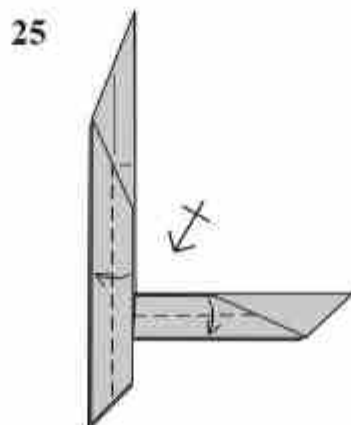
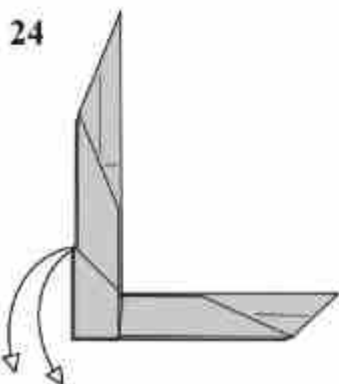

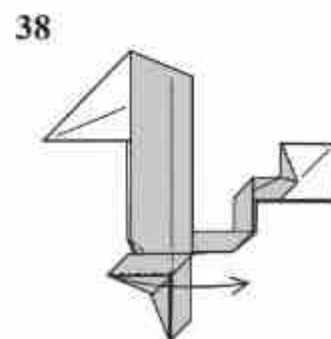
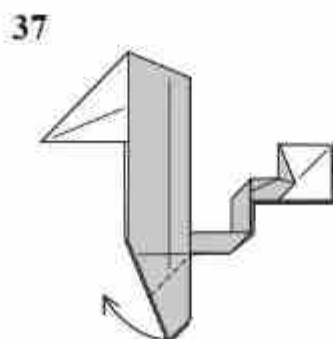
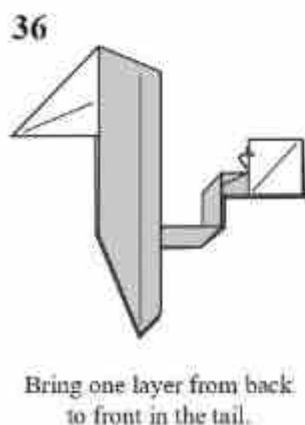
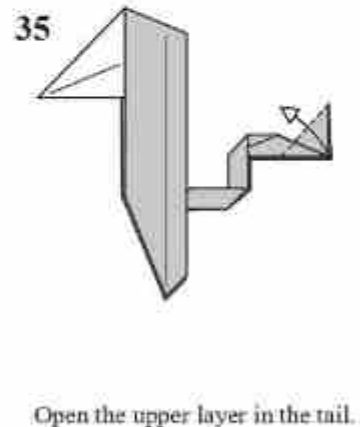
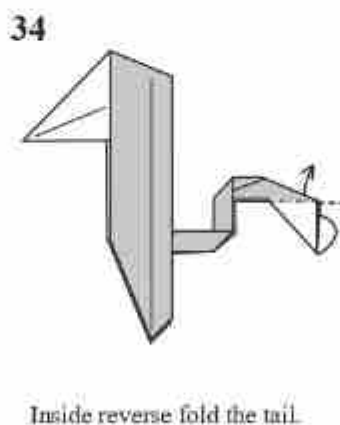
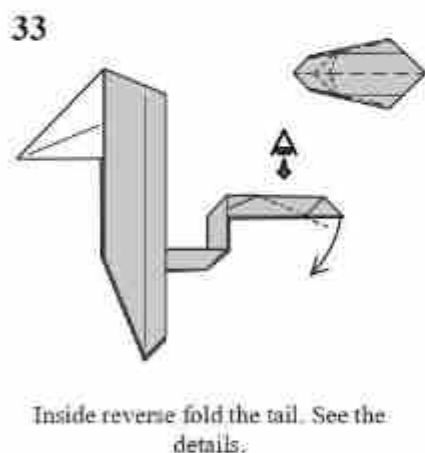
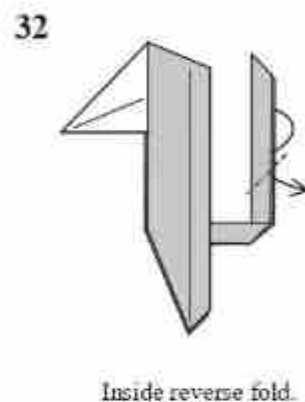
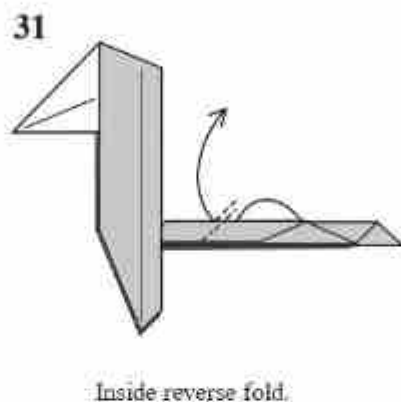
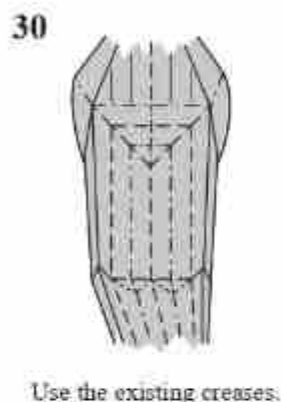
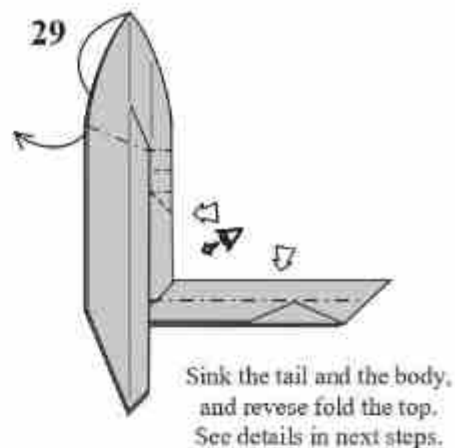
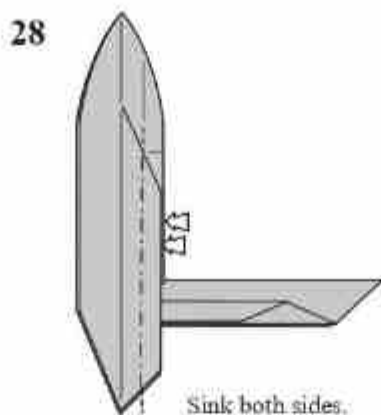
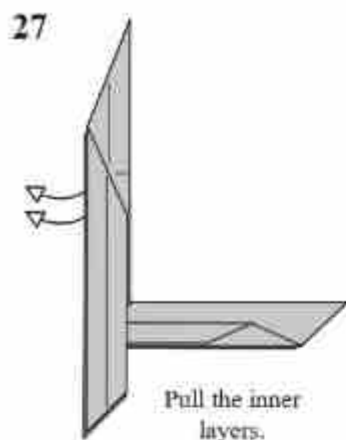

39

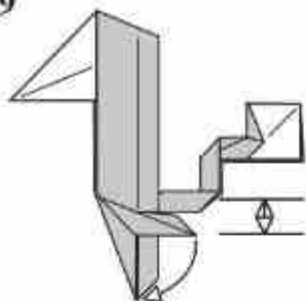

The leg and the tail has to be parallel.
Unfold last step.

40

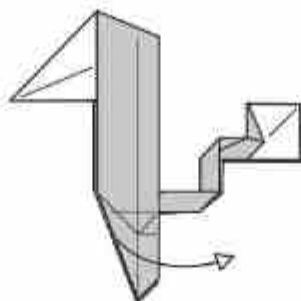

Open the upper layer.
The model will not be flat.

41

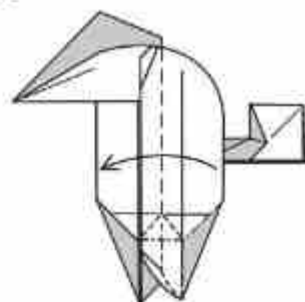

Fold using the existing creases.
The model will be flat.

42

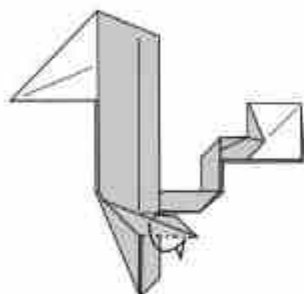

Move the upper layer back over all leg layers. (sink)

43

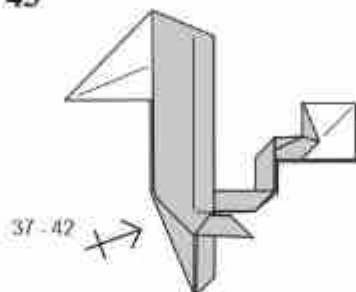

Repeat steps 37- 42 in other leg

44

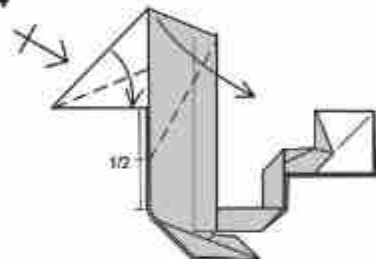

Swivel. Repeat behind.

45

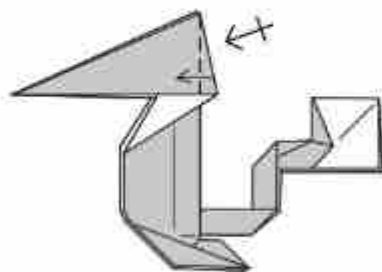

46

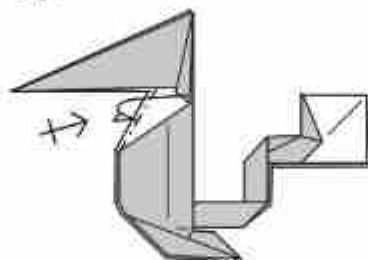

Tuck the layer inside. Repeat behind.

47

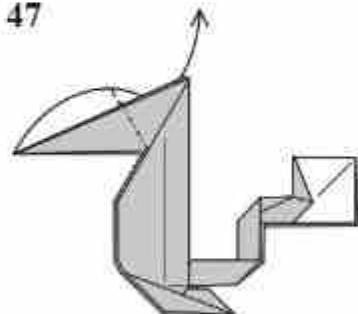

Inside reverse fold.

48

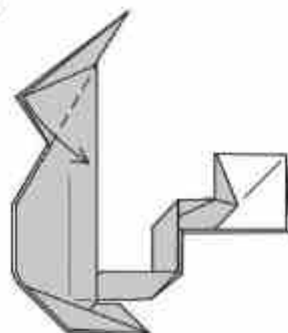

Open the upper layer.

49

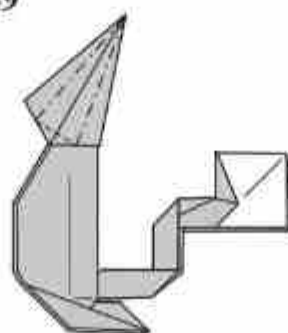

Petal fold.

50

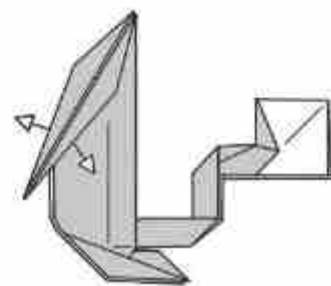

Pull excess paper.

51

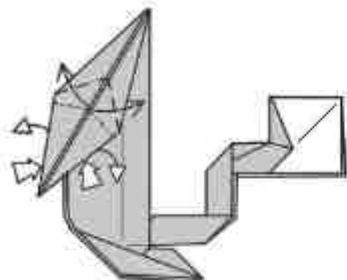

52

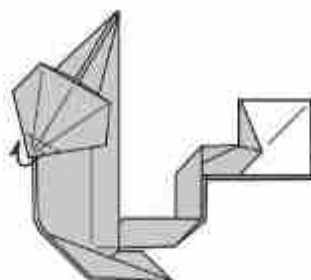

53

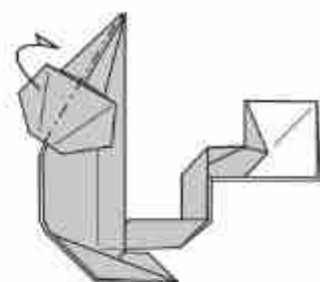

Push the head behind while incorporating the creases. Full excess paper out.

54

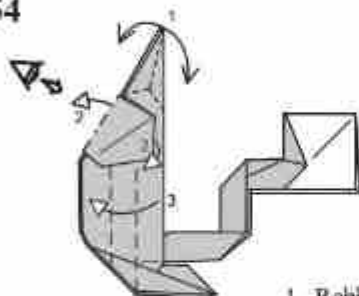

55

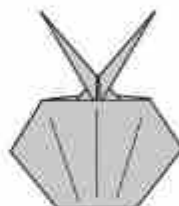

Shape the model.

- 1 Rabbit ears.
- 2 Open the head.
- 3 Round the body.

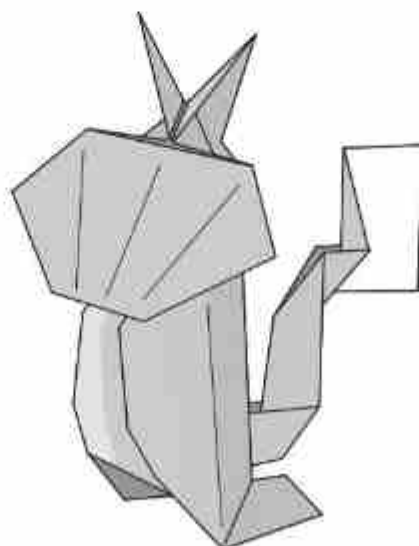

Stork

Intermediate

Rhanu Pradipta
©2021 - Indonesia

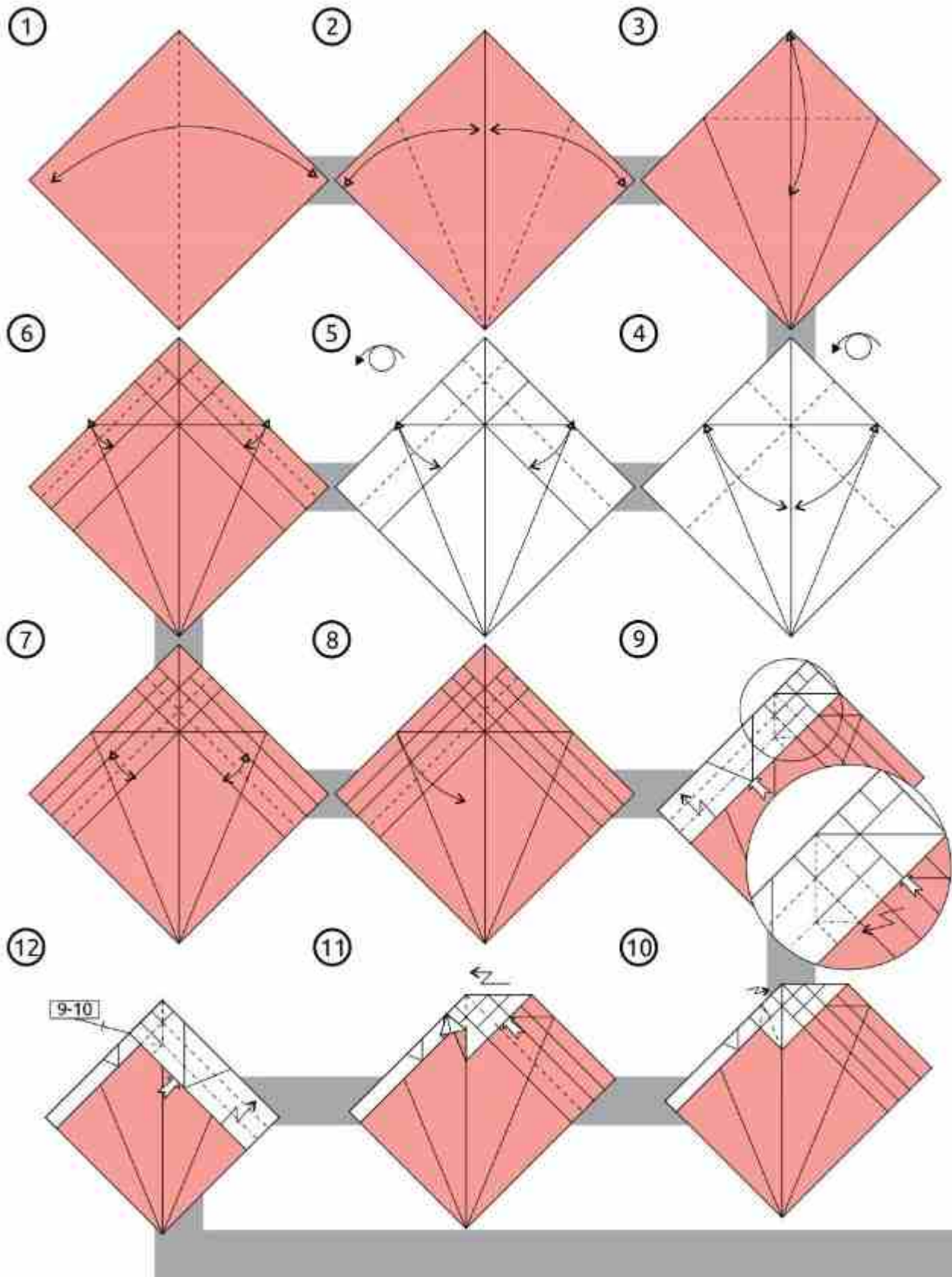

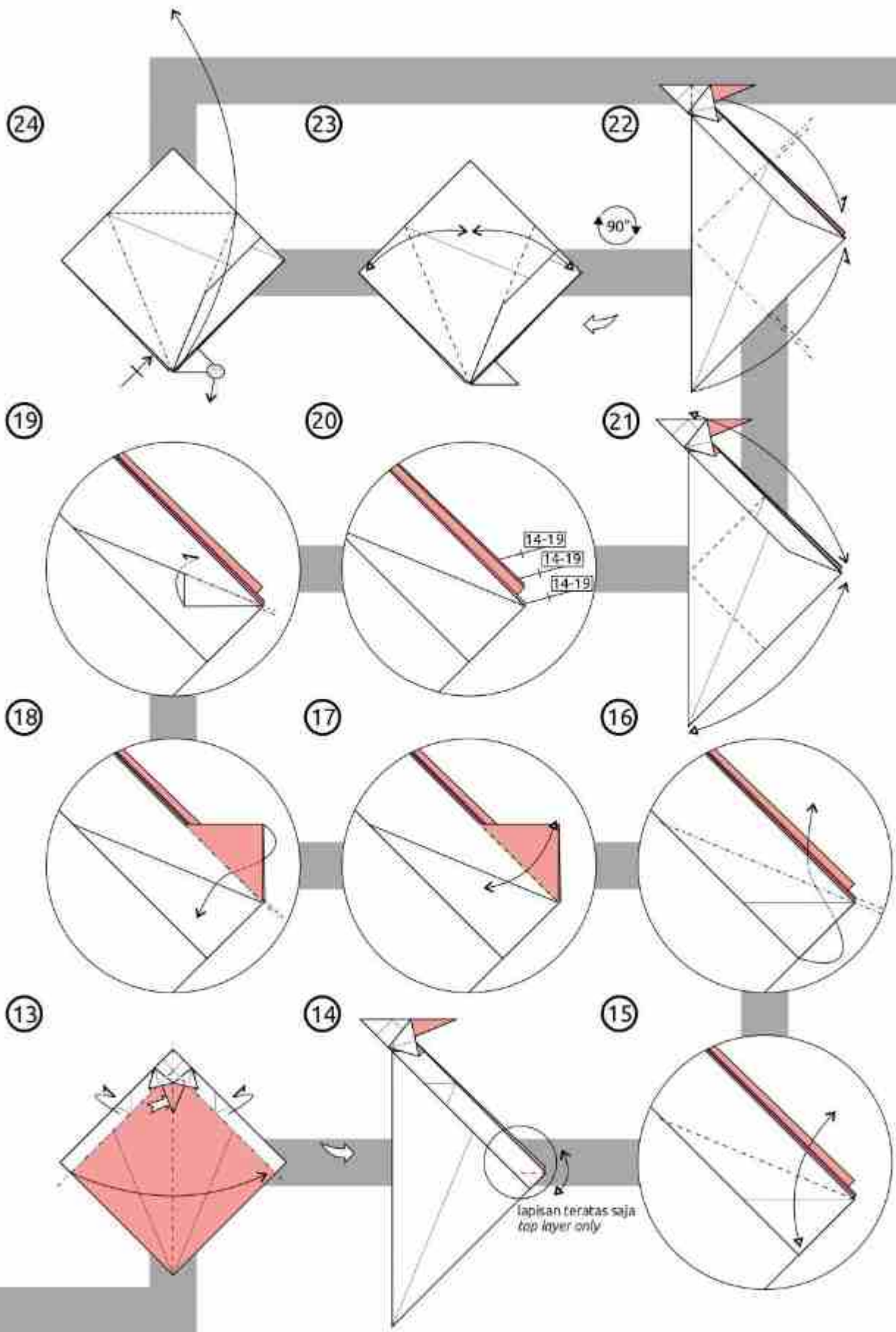

25

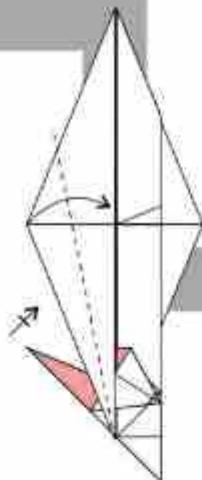

26

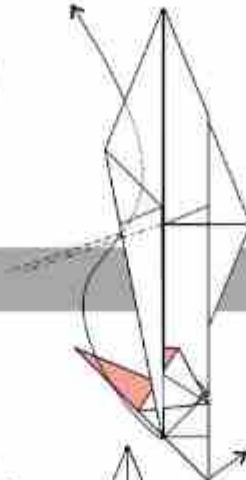

27

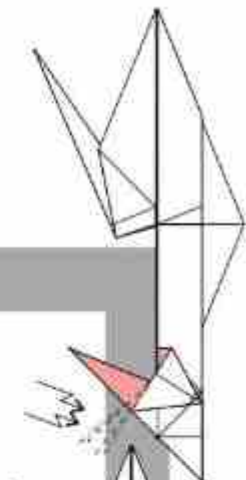

30

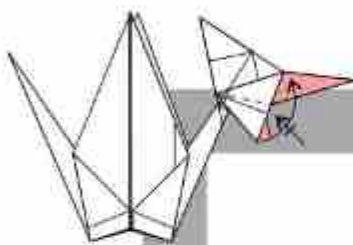

29

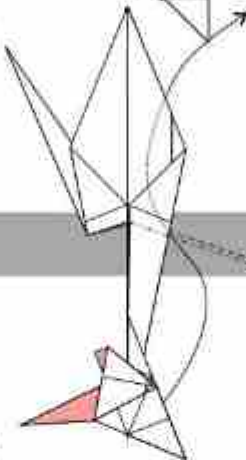

28

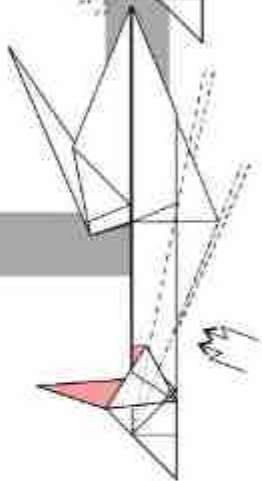

31

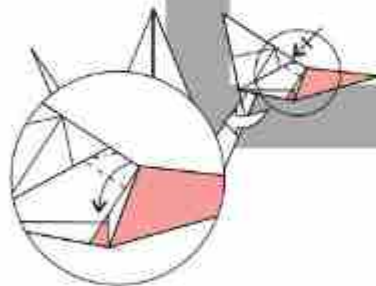

32

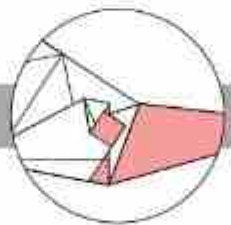

33

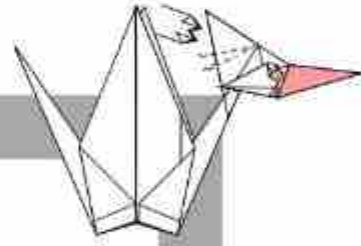

35

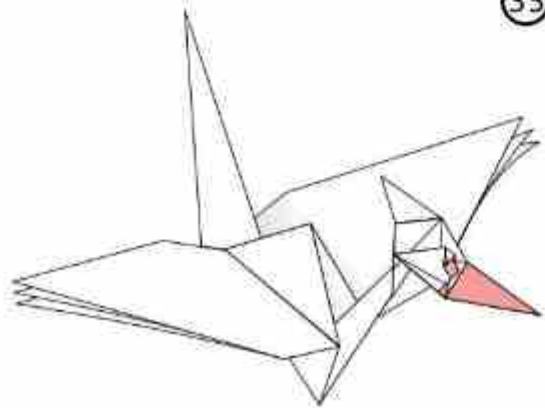

34

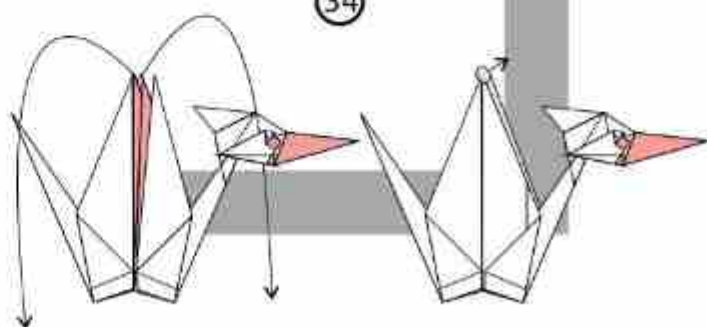

Horse

Intermediate

Leonardo Pulido Martinez

©2022 - Colombia

Paper: Square de 20 x 20 cm, no cuts

(Wet Fold)

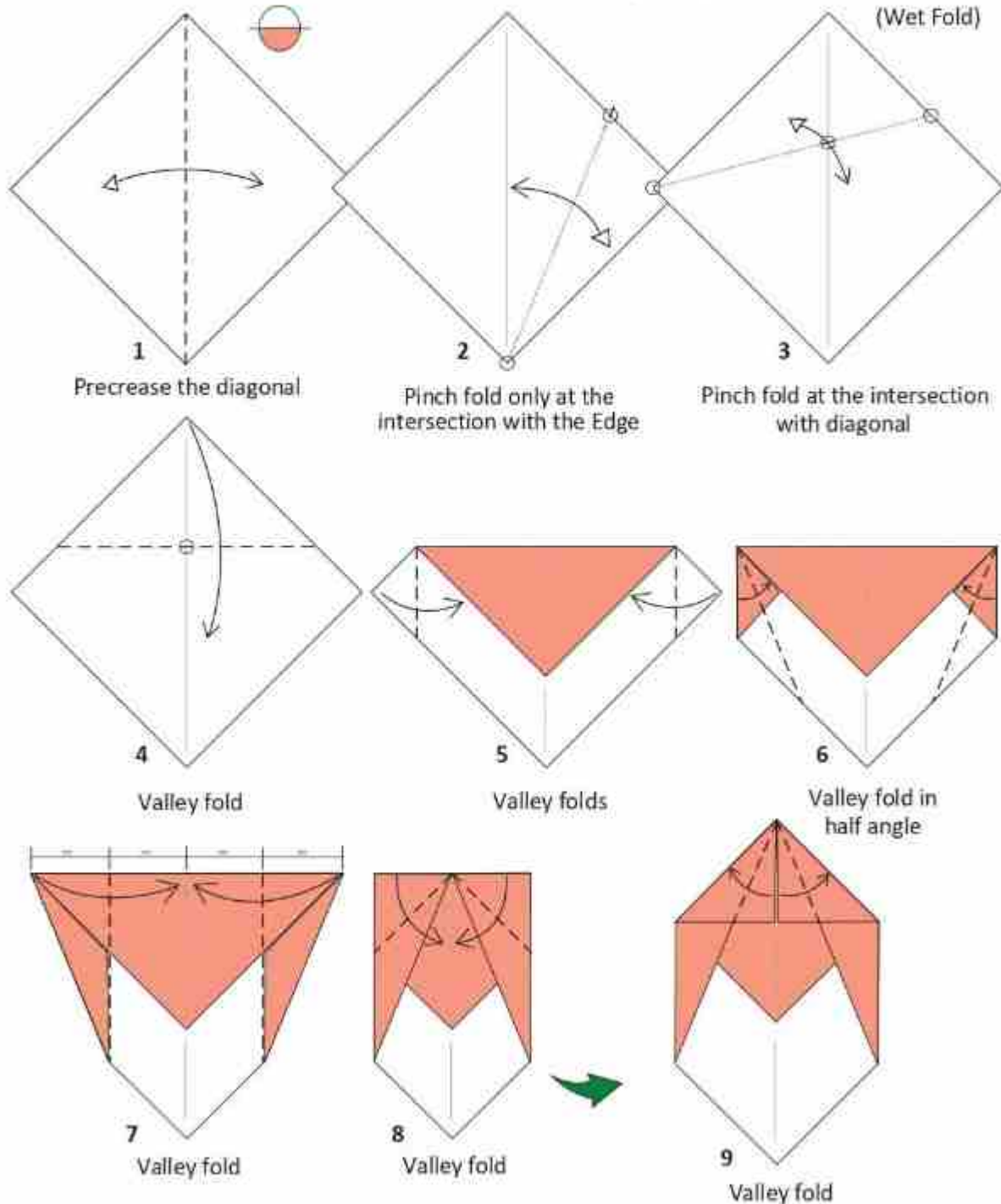

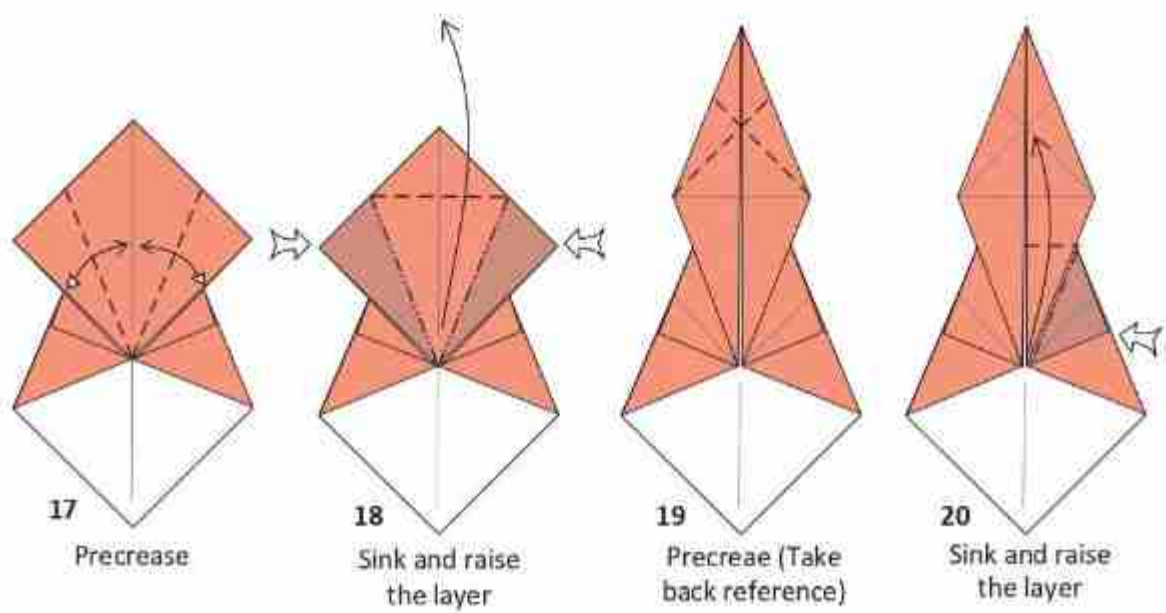
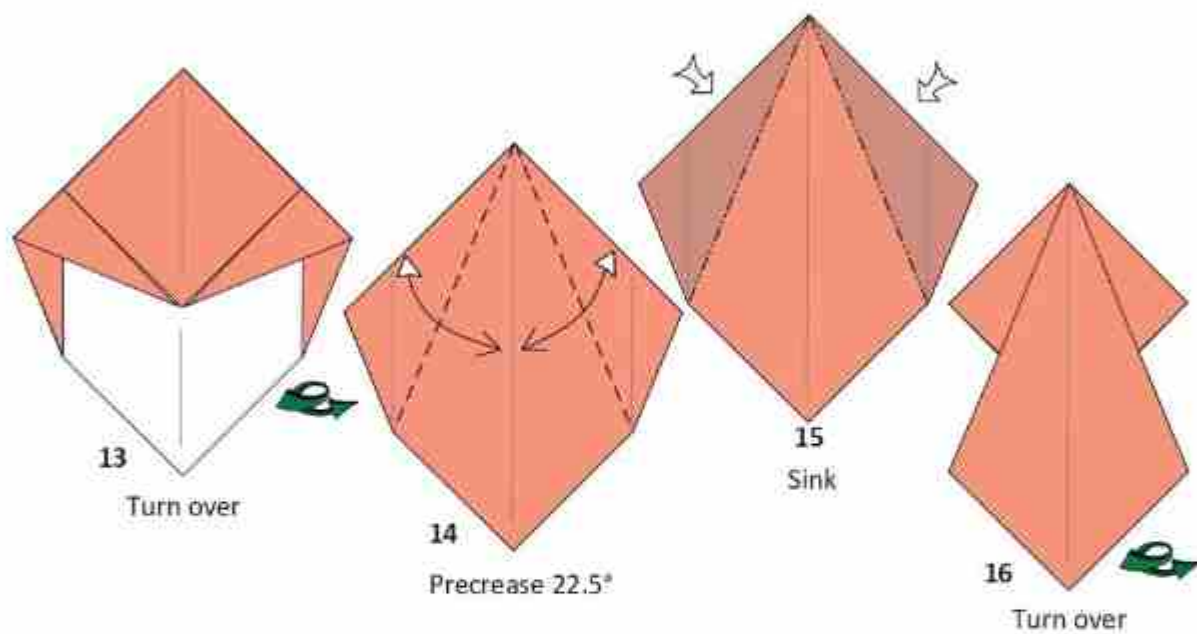
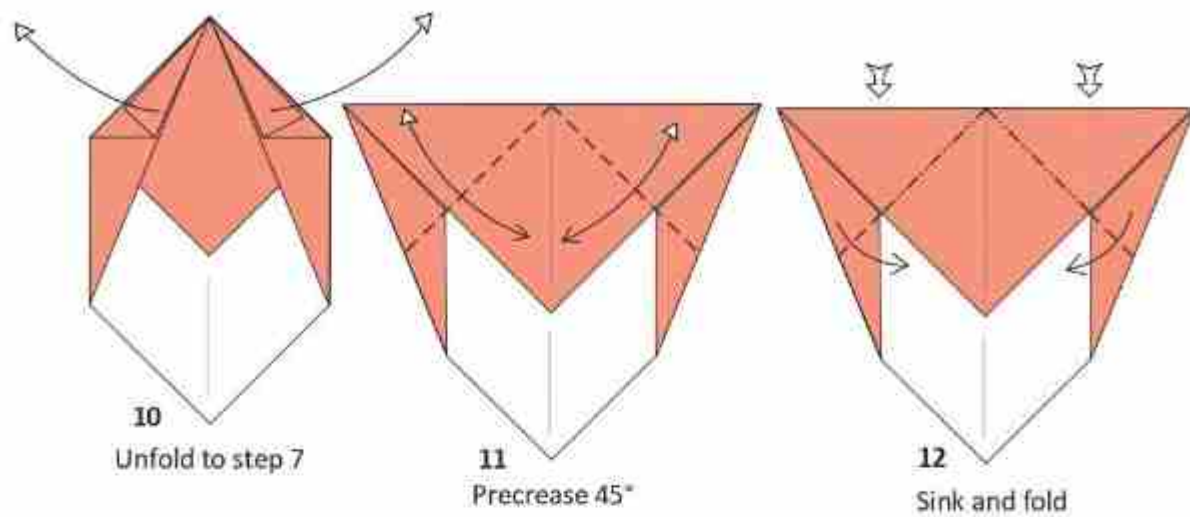

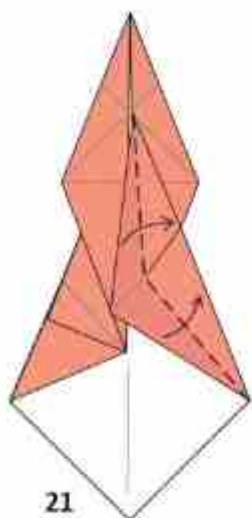

21
Valley fold
(intermediate step)

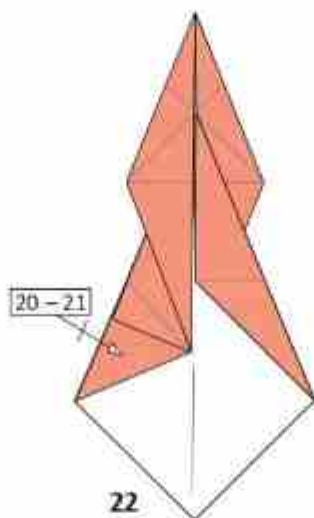

22
Repeat symmetrically

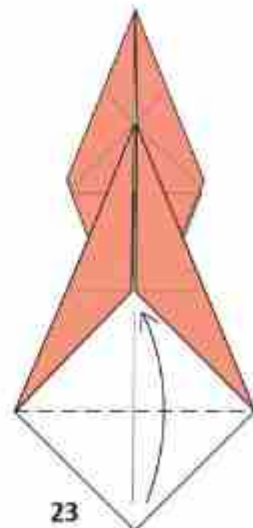

23
Valley fold

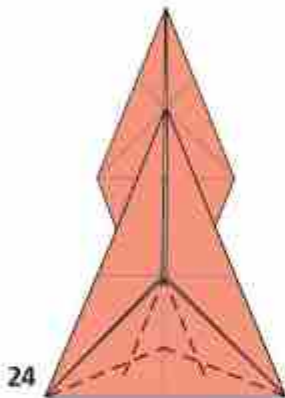

24
Precrease 22.5°

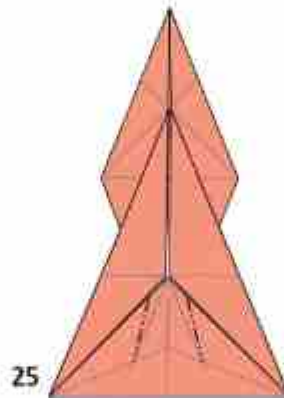

25
Pre-crease

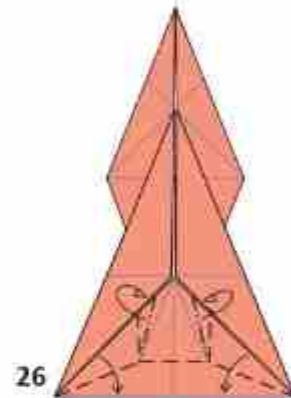

26
Fold by marks

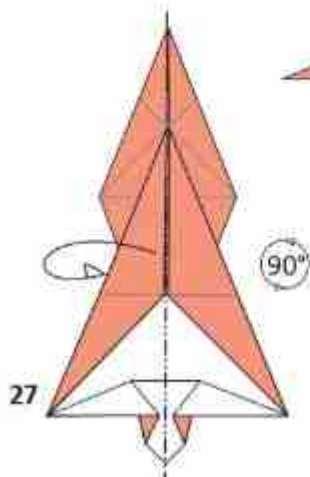

27
Mountain fold in
half and rotate

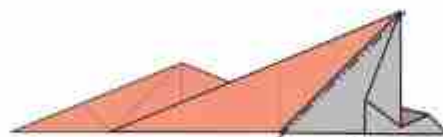

28
Sink

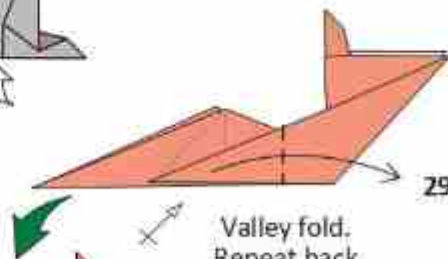

29
Valley fold.
Repeat back

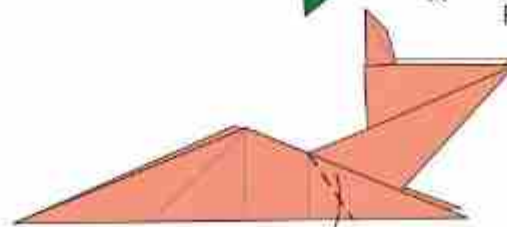

30
Valley fold.
Repeat back

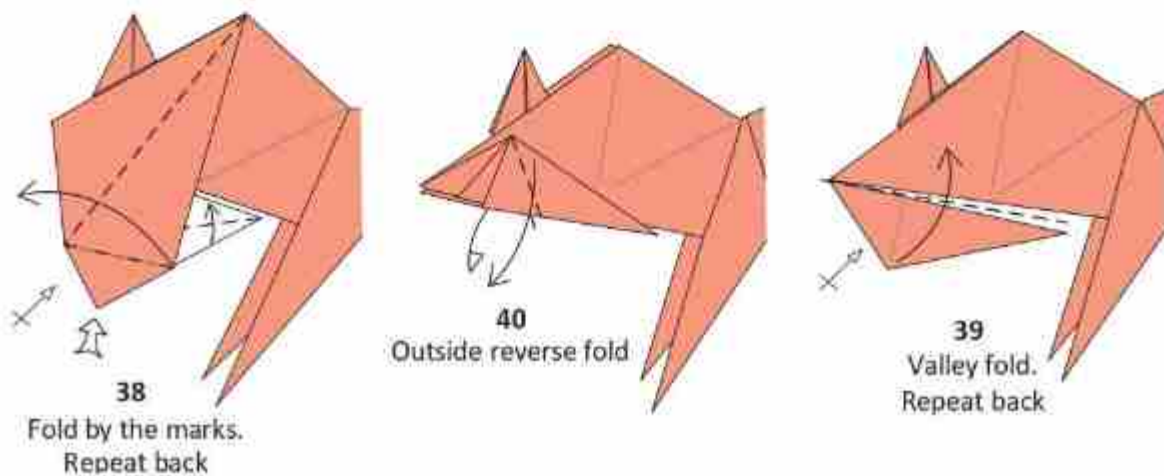
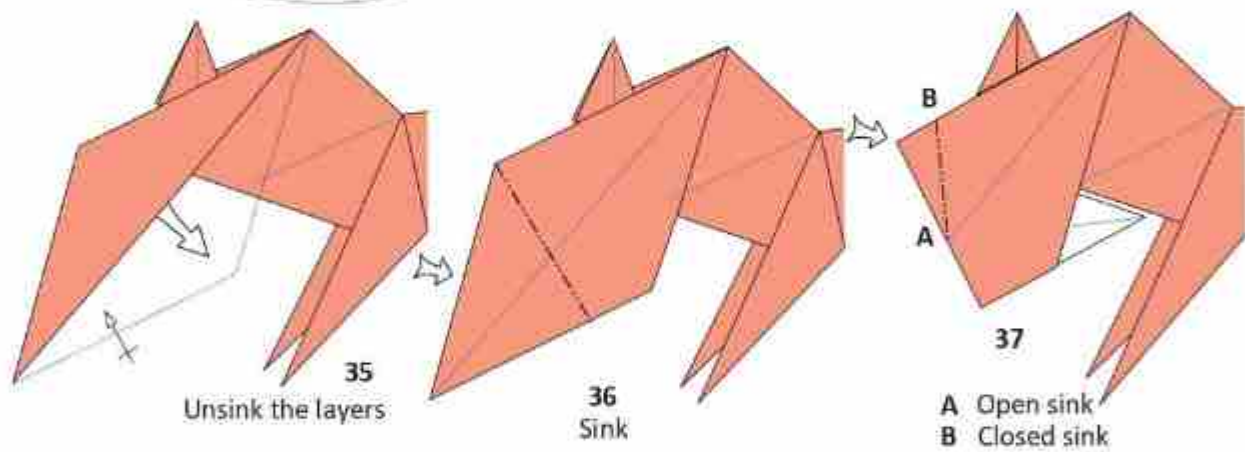
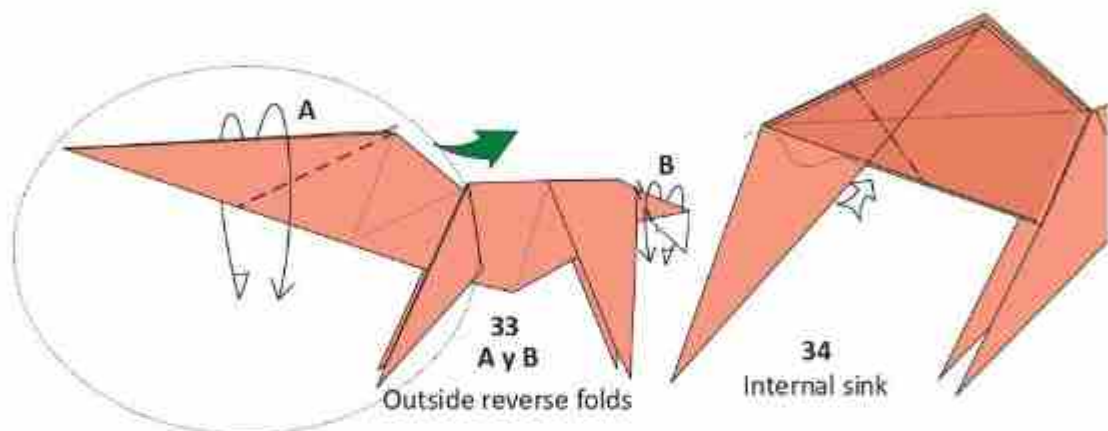
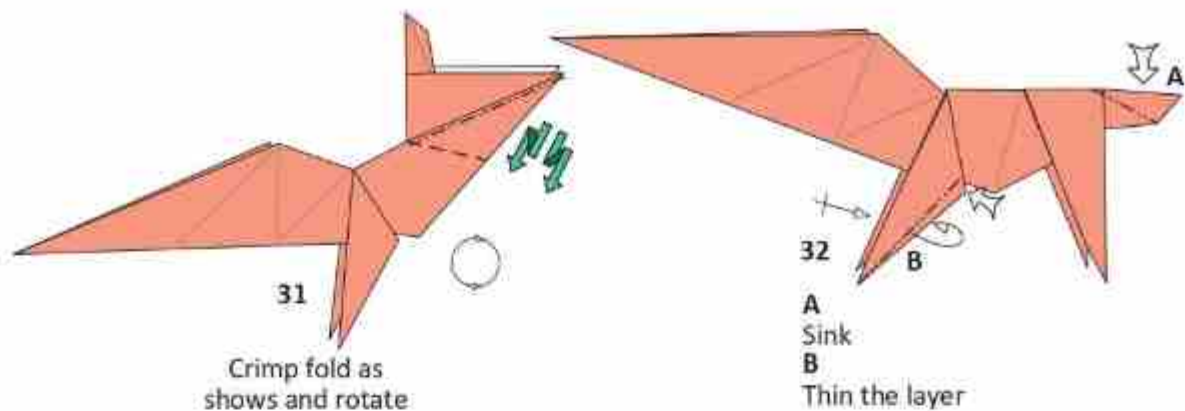

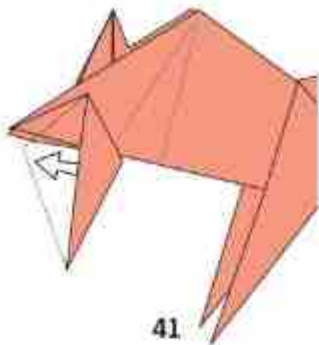

41
Unfold the layer

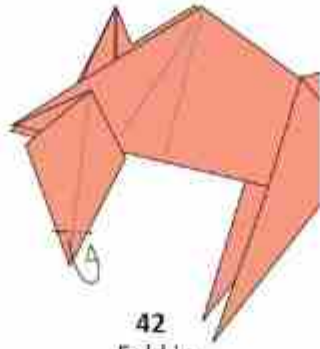

42
Fold in

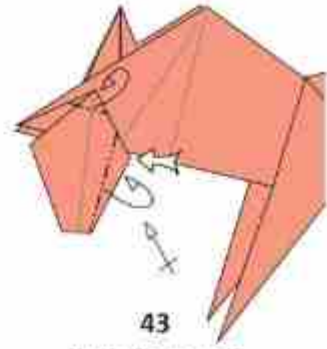

43
Thin the layers

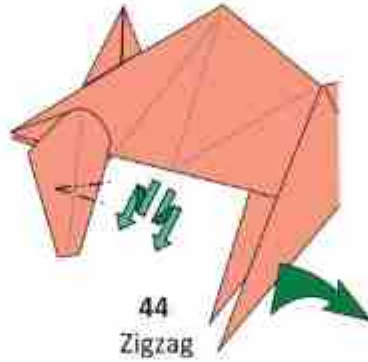

44
Zigzag

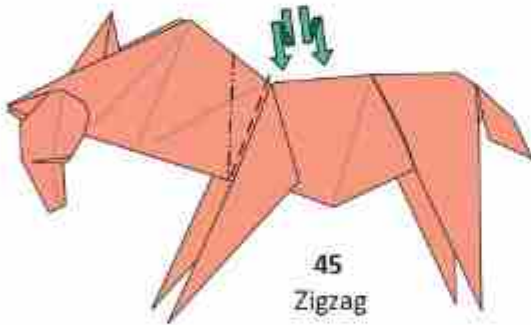

45
Zigzag

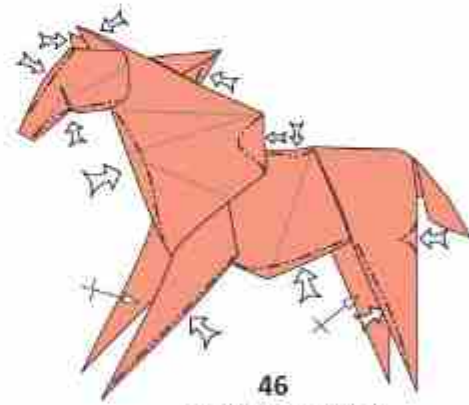

46
Shape the model

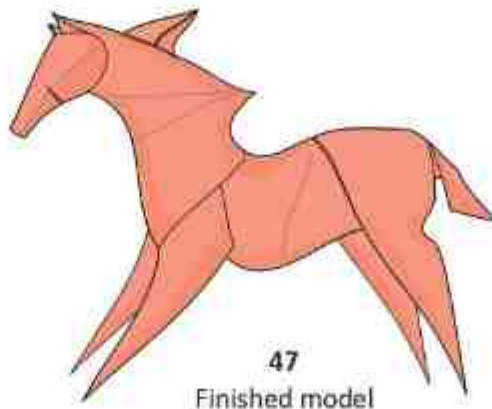

47
Finished model

Kupu-Kupu Pentafly

Wuri Dyah Putranti
Hadi Tahir (dgrms.)
©2022 - Indonesia

Intermediate

siapkan pentagon tanpa
jejak lipatan

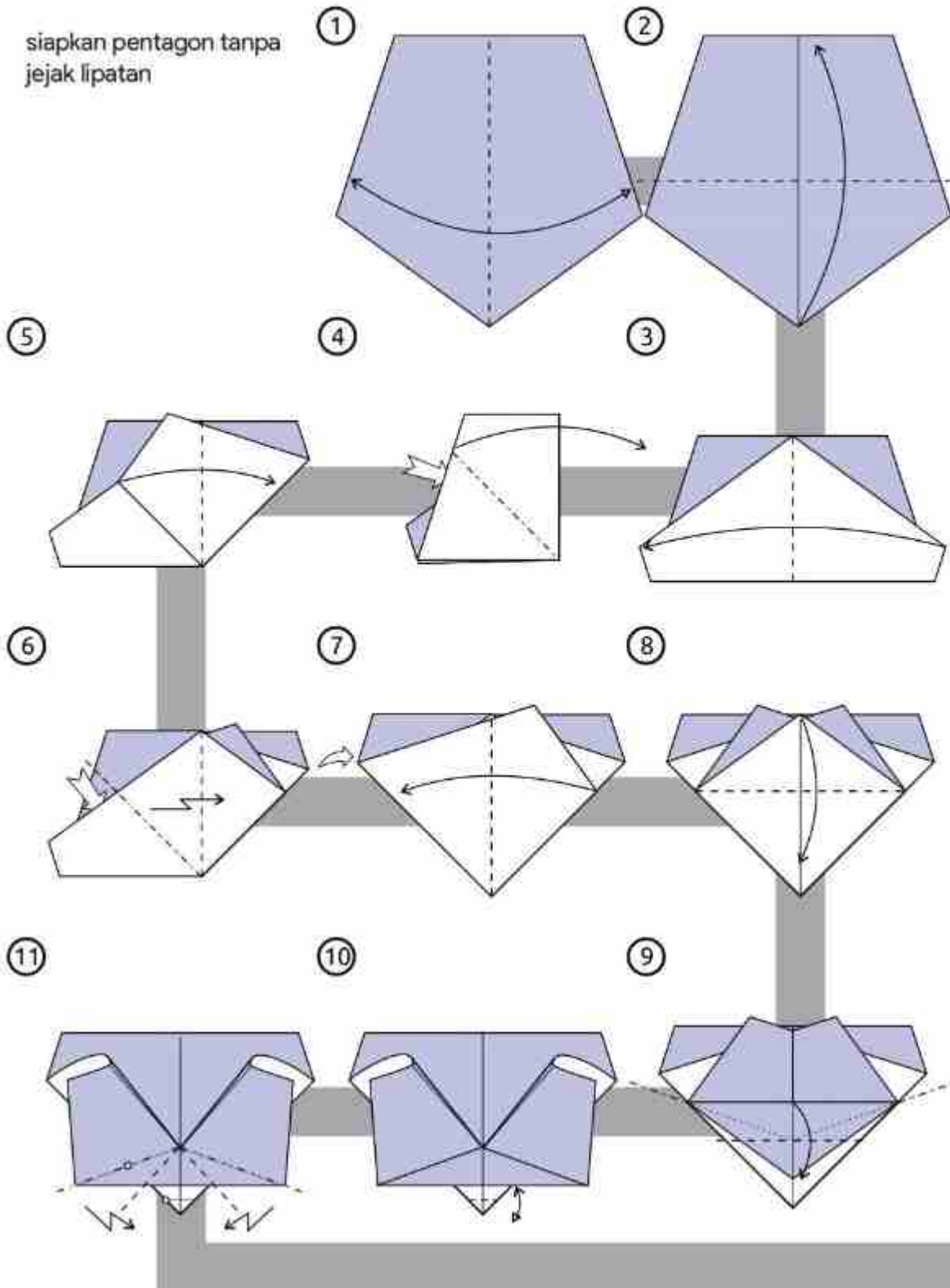

perbandingan ukuran kertas
dan ukuran model jadi



21

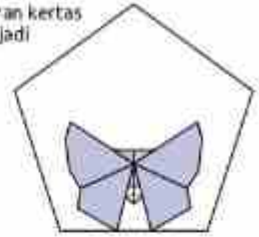

20

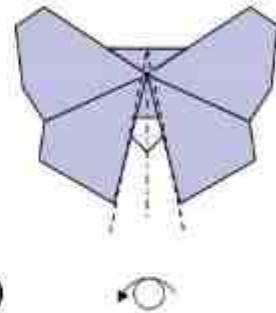

18

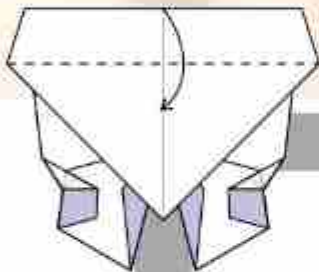

19

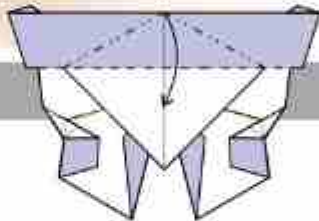

17

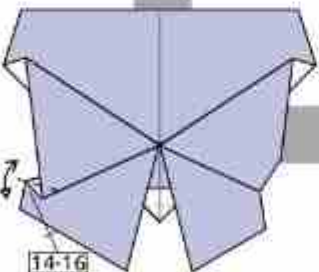

16

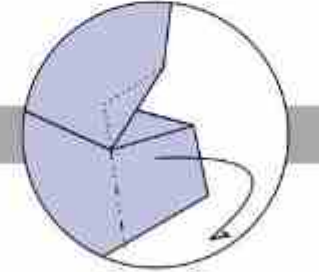

15

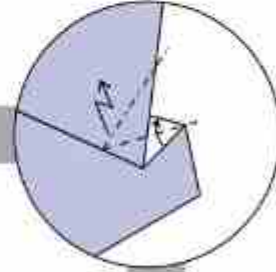

12

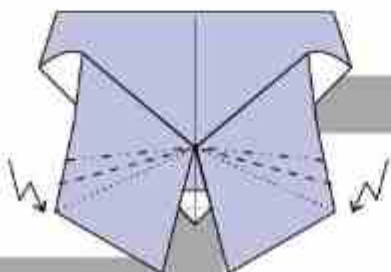

13

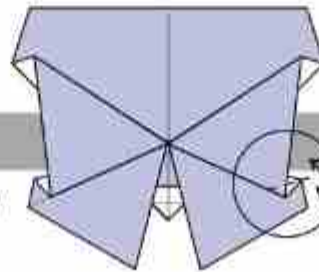

14

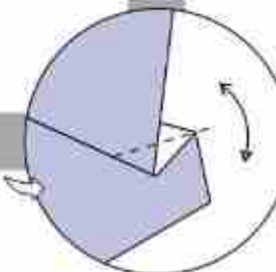

Sheep

Intermediate

Li Qingquan

©2023 - China



20cmx20cm

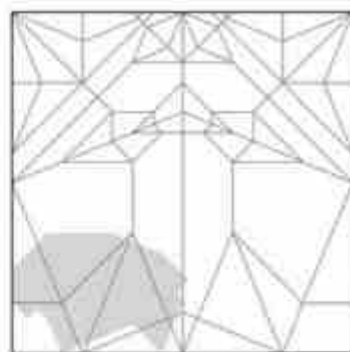
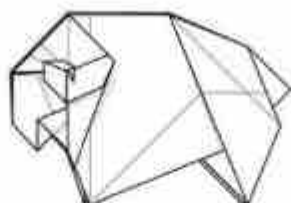

01

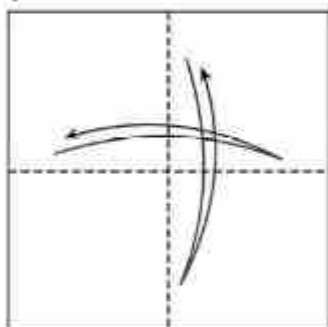

02

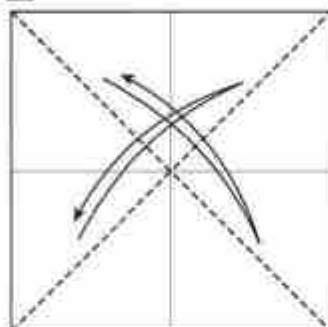

03

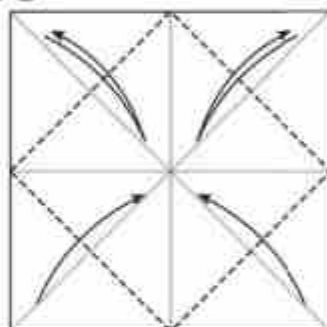

04

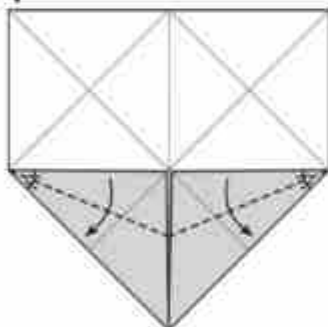

05

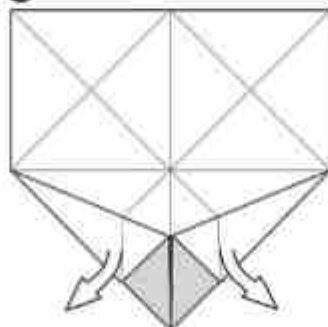

06

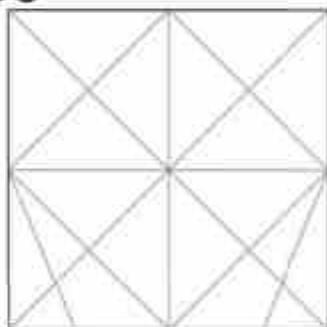

07

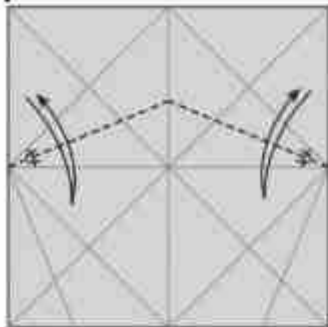

08

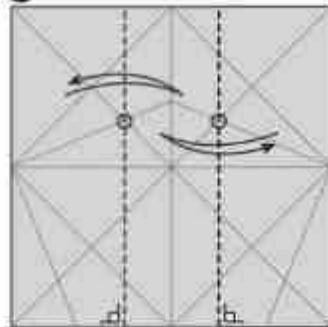

09

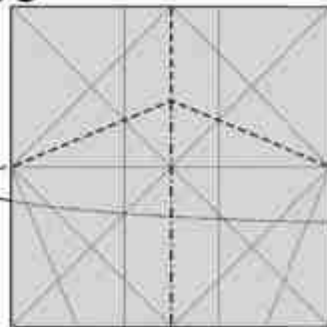

10

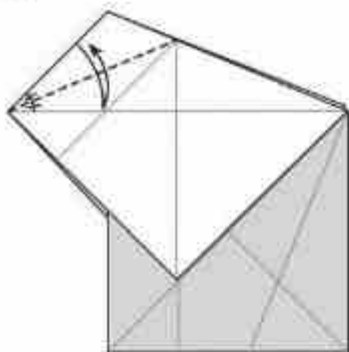

11

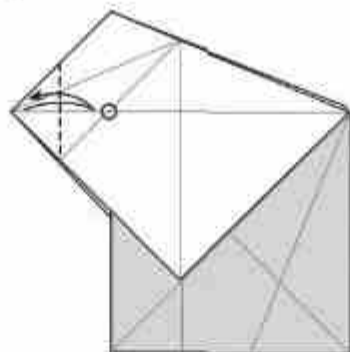

12

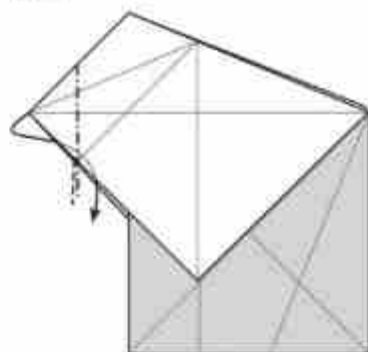

13

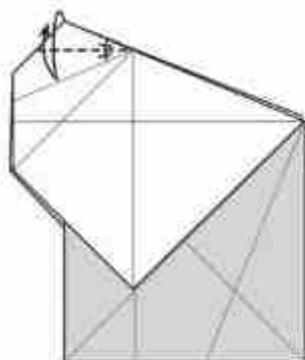

14

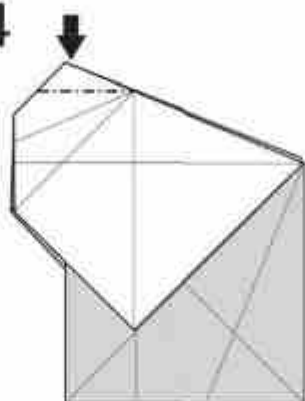

15

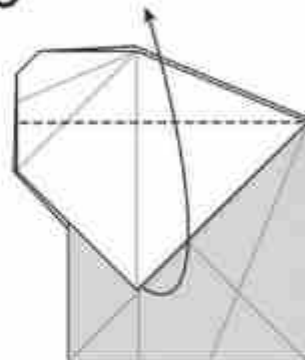

16

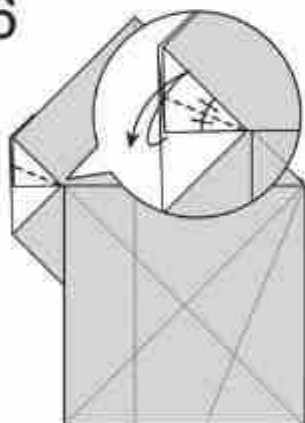

17

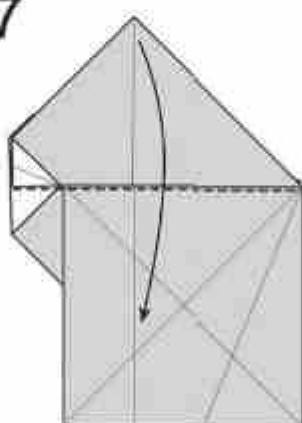

18

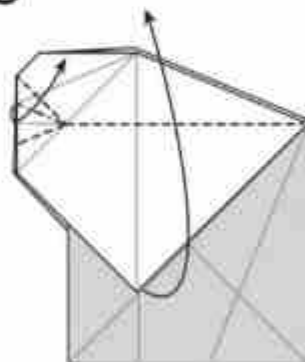

19

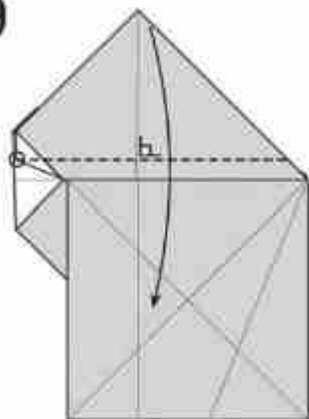

20

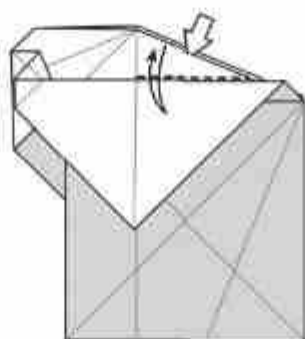

21

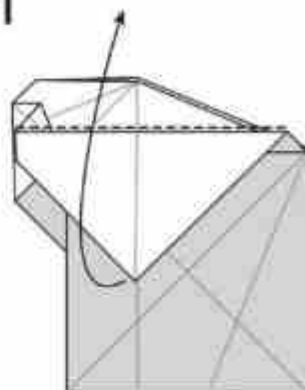

22

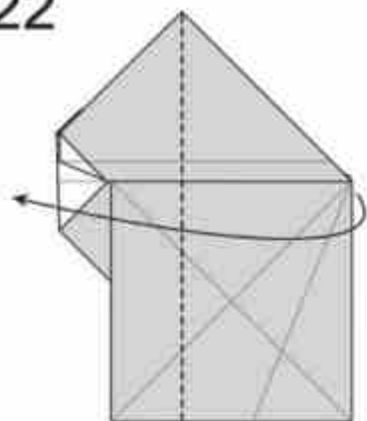

23

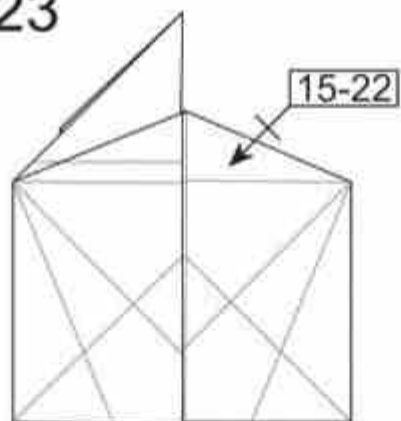

24

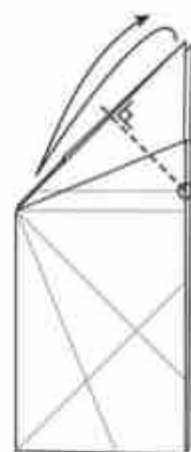

25

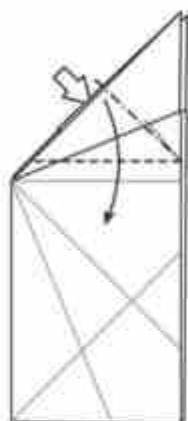

26

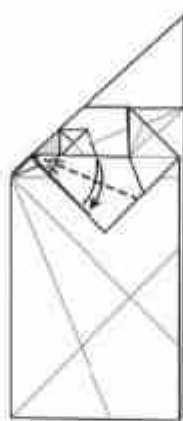

27

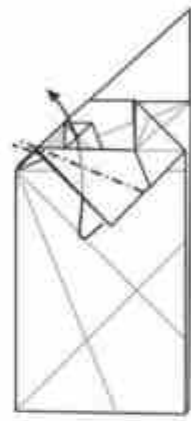

28

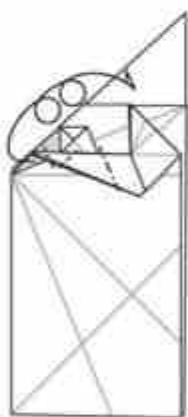

29



30

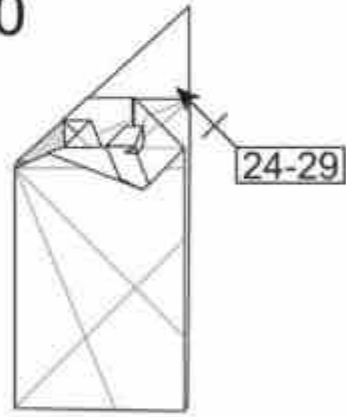

31



32

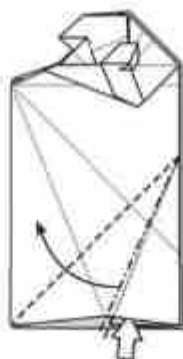

33

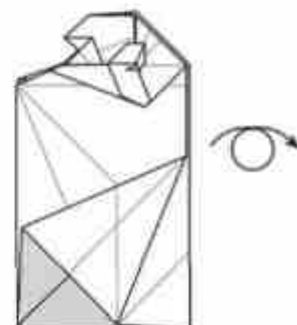

34

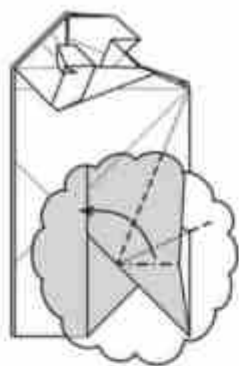

35

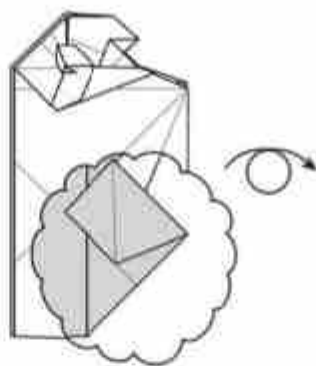

36

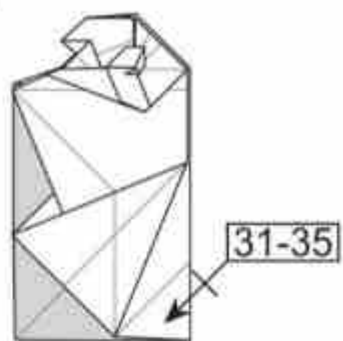

37

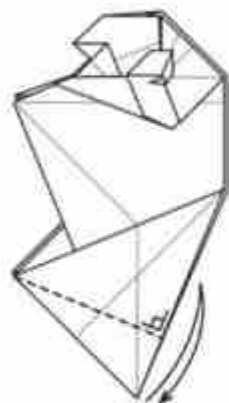

38

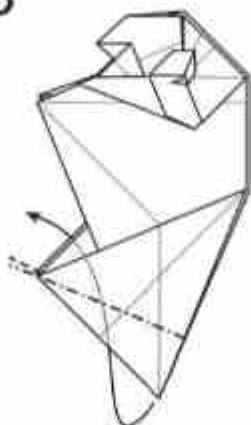

39

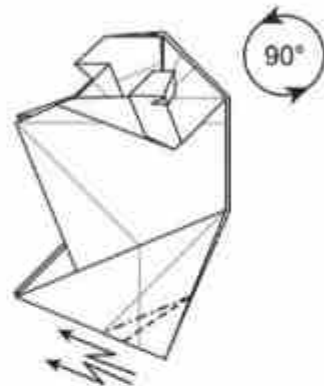

40

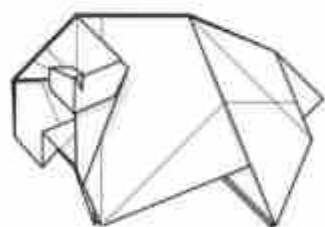

Pear

Jane Rosemarin

©2020 - USA

Low Intermediate

Use duo paper in a 3:1 proportion.



1. Pear color up, match edges and pinch where indicated.



2. Fold side to side, stopping approximately at the level of the pinch.

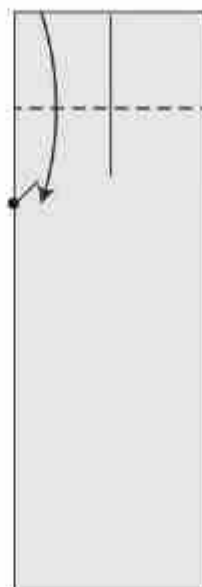

3. Valley fold to pinch.



4. Valley fold to top edge.



5. Turn the paper over.



6. Fold top edge to vertical crease.



7. To form leaves, fold top layer out at an angle slightly steeper than 45 degrees so points protrude beyond the edges.

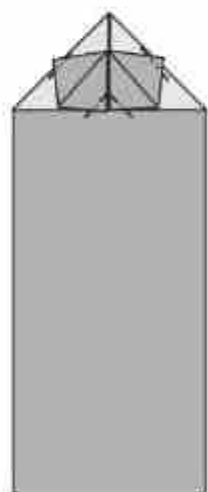

8. Shape leaves with tiny mountain folds.

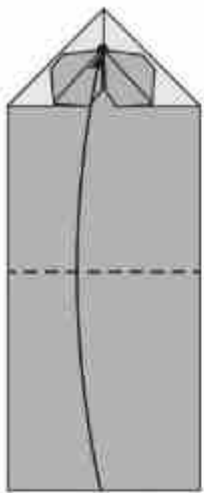

9. Bring the bottom edge up to the very top of the leaves and crease.

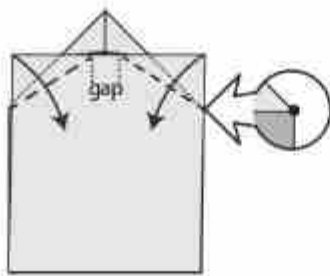

10. Make valley folds, beginning at each outer edge exactly where the colors change in the lower layer (see detail) and ending to the sides of the top center (see next illustration).

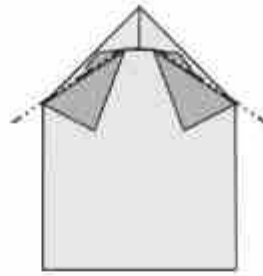

11. Reverse the folds to mountain folds.

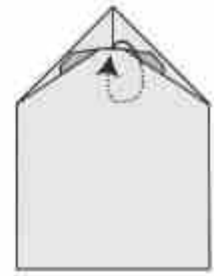

12. Tuck the top layer under the leaves.

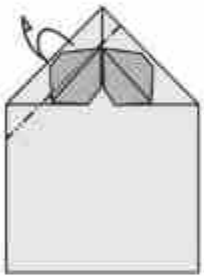

13. Mountain fold parallel to the angled edge through all layers beneath the leaf. Crease firmly and unfold.

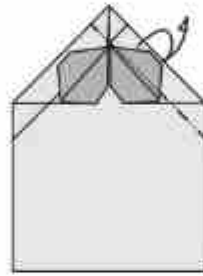

14. Repeat on the right side.

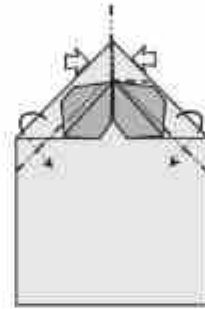

15. Using existing mountain creases, make a rabbit-ear fold.

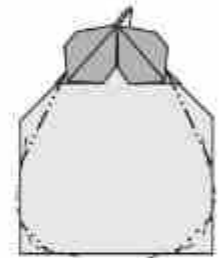

16. Make mountain folds to shape the pear. First form the folds shown with bold lines, then add smaller folds to round the form.

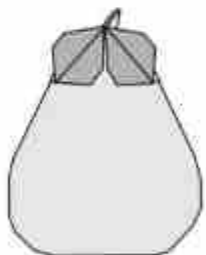

17. Done.

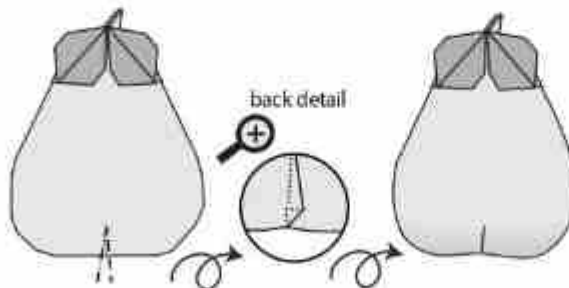

Optional: You may round the fruit by making a small pleat at the bottom. You can lock it with a very small mountain fold.*

*Thanks to Dawn Erickson for this suggestion.

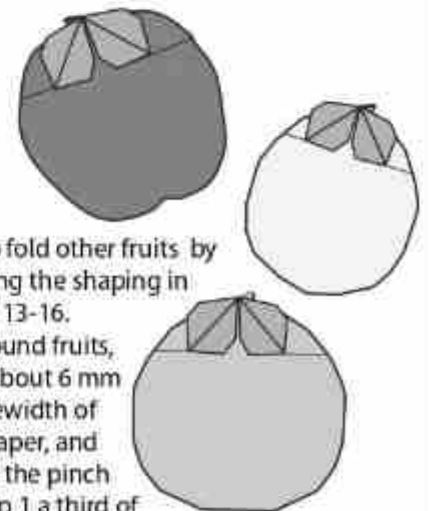

Try to fold other fruits by altering the shaping in steps 13-16. For round fruits, add about 6 mm to the width of the paper, and make the pinch at step 1 a third of the distance from the top.

Iso-Area 4x4 Checkerboard

Jeremy Shafer

©2003 - USA

High Intermediate

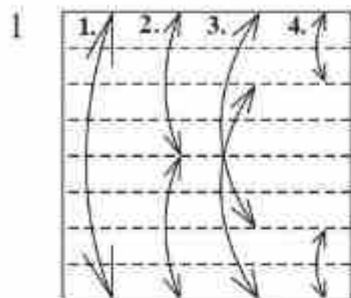

1 With the white side up, divide the paper into eighths by folding it in half, then in quarters and then in eighths. **Turn over.**

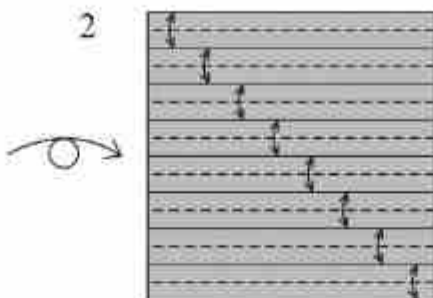

2 With colored side up, divide the paper into sixteenths by putting a valley fold in between each pair of mountain creases, making a paper fan.

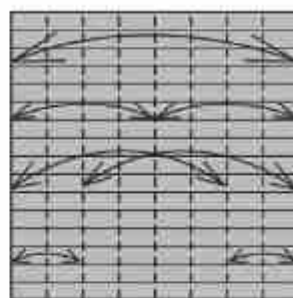

3 Repeat step 1 with the colored side up, making the valley folds perpendicular to the existing creases. **Turn over.**

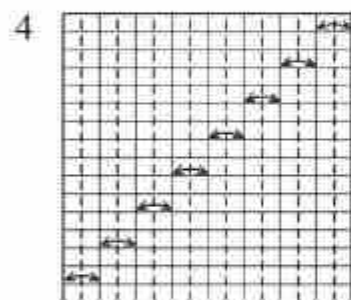

4 With the white side up, put a valley fold in between each pair of mountain creases from step 3, making a paper fan in the other direction.

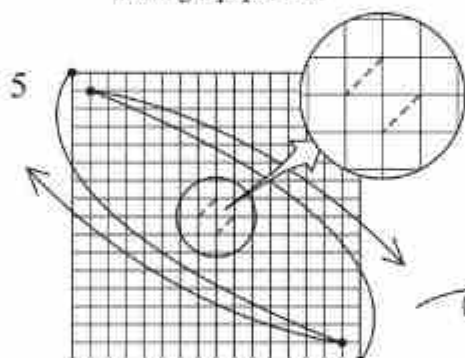

5 Following the fold-and-unfold arrows, pinch two tiny valley creases in the center. **Turn over.**

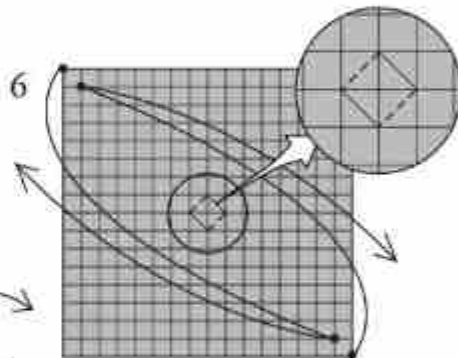

6 Following the arrows, pinch two tiny valley creases in the center.

7

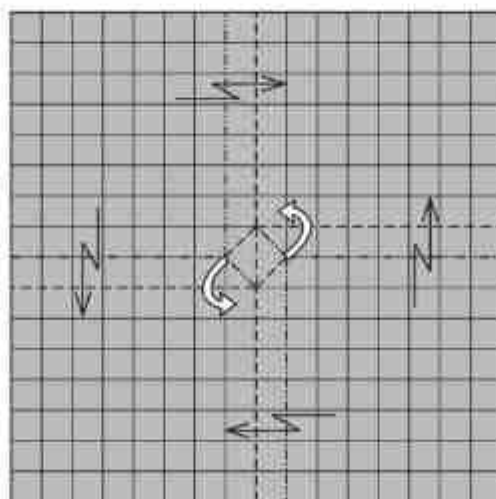

Using existing creases, make the indicated mountain and valley folds. This will cause the little square in the center to make a quarter turn. Toshikazu Kawasaki calls this fold an 'iso-area square twist.' 'Iso-area' means, 'both sides look the same but are opposite in color and orientation.'

8

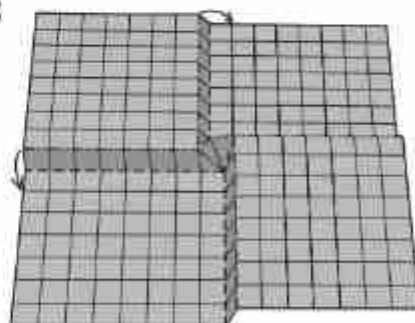

Iso-area square twist in progress.

9

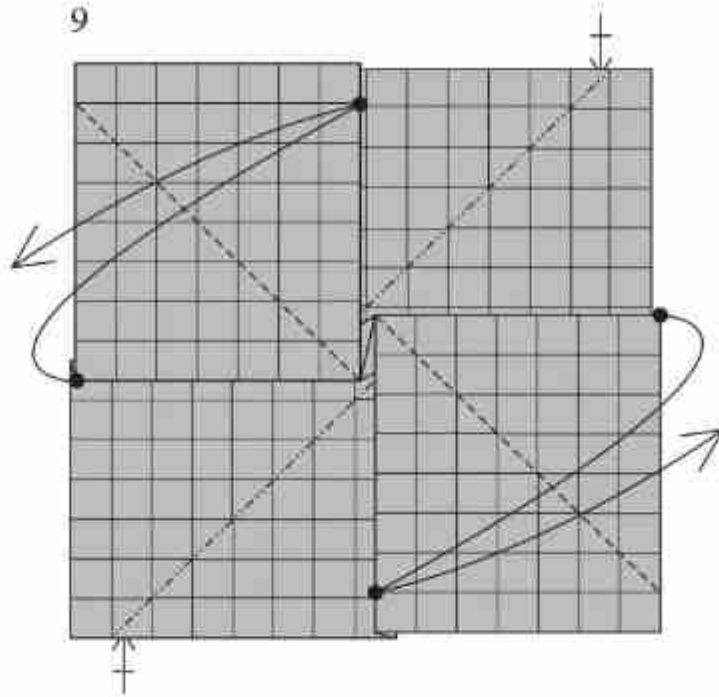

Following the arrows, make the diagonal valley creases. Repeat behind for the mountain folds. Note that these creases do not touch the corners of the model.

10

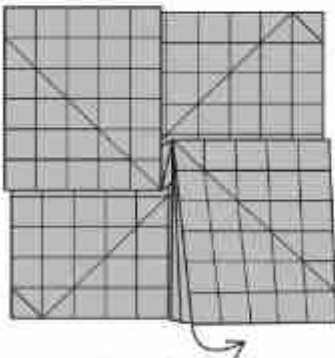

Open the pleats on the bottom edge.

11

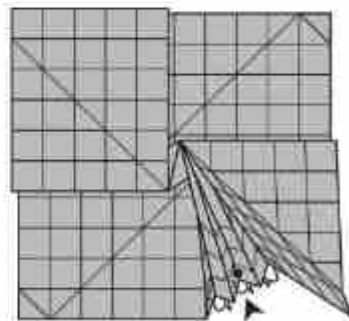

Mountain-fold the raw edge and then apply pressure on the black dot to collapse the model flat.

12

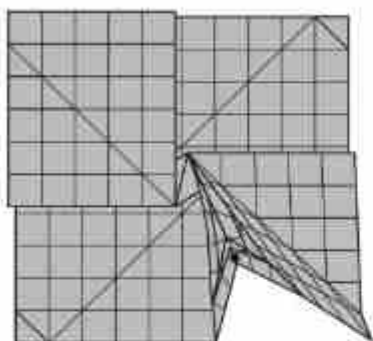

In progress.

13

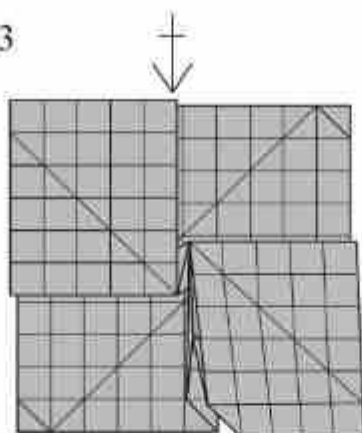

Repeat steps 2-4 on the top edge.

14

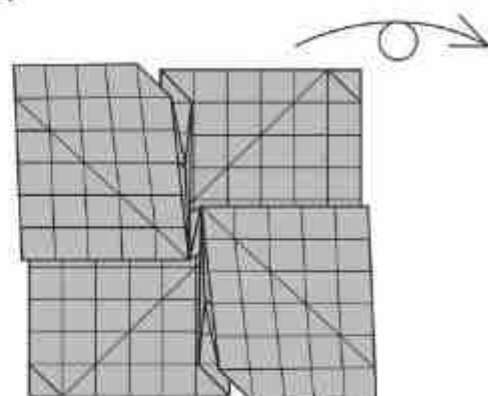

Turn over.

15

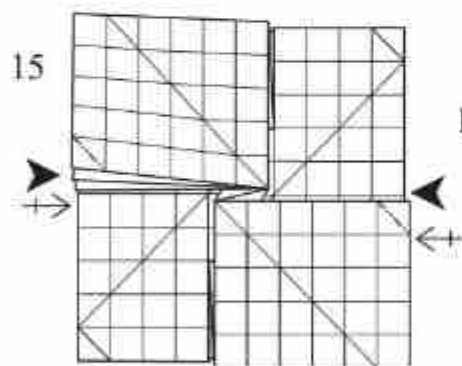

Repeat steps 2-4 on the left and right edges.

16

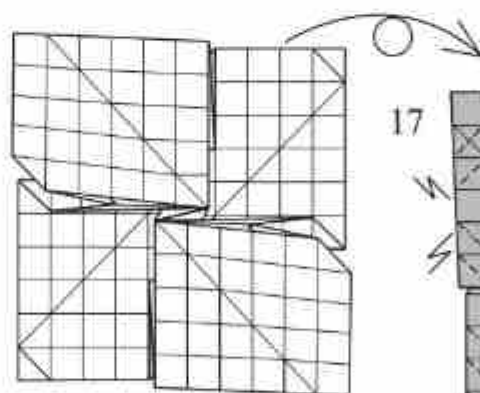

Turn over.

17

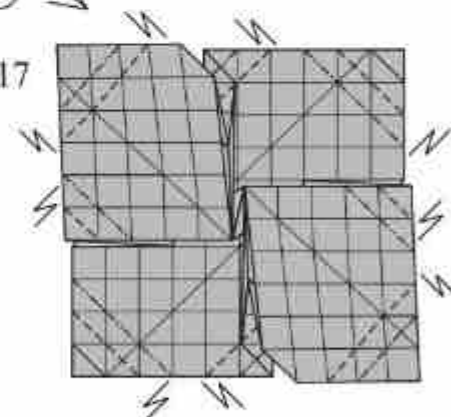

Make the eight indicated pleats.

18

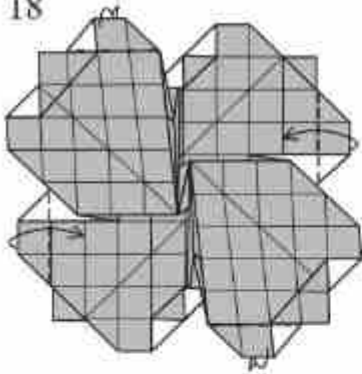

Valley-fold on the left and right.
Mountain-fold on the top and bottom.

19

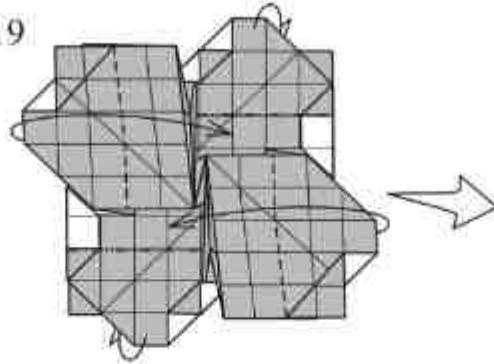

Valley-fold on the left and right. Mountain-fold on the top and bottom.

20

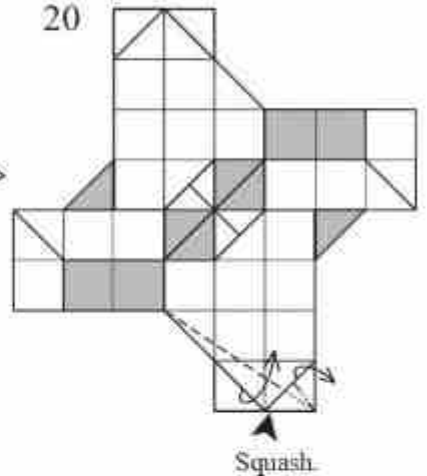

Squash.

21

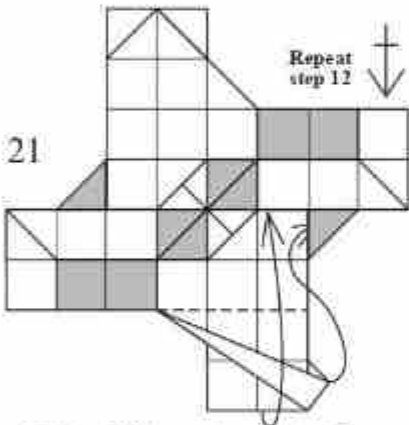

Valley-fold, inserting the tiny flap into the pocket. Repeat step 12 on the right flap.

22

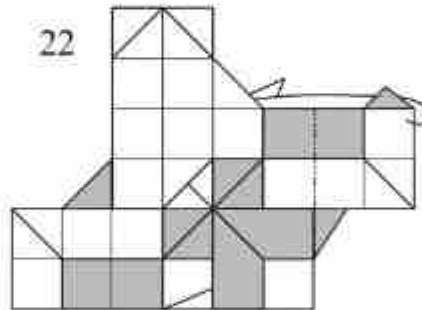

Repeat step 13 on the right flap.

23

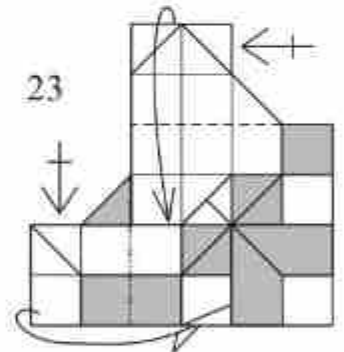

Repeat step 13 on the top flap and then, finally, on the left flap. The inserting of the final tiny flap is a bit tricky; you need to partially undo the first step 12 squash in order to make room.

24

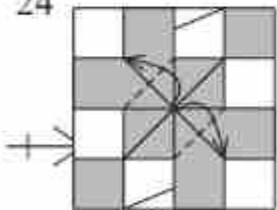

Valley-fold to complete the checkerboard. Repeat behind.

25

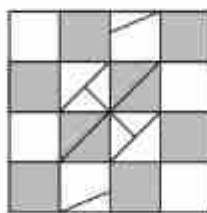

26

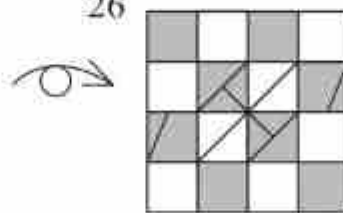

The Checkerboard is complete and completely the same on the other side! **Turn over.**

5x5 Pixel Grid

Hadi Tahir

©2022 - Indonesia

High Intermediate

① 16x16

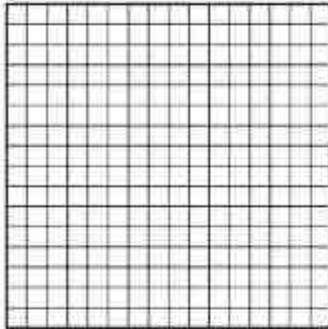

②

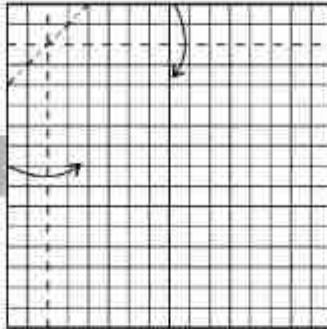

③

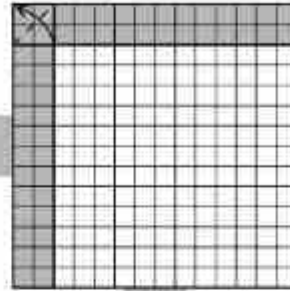

⑥

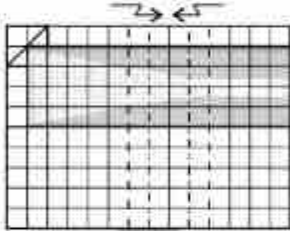

⑤

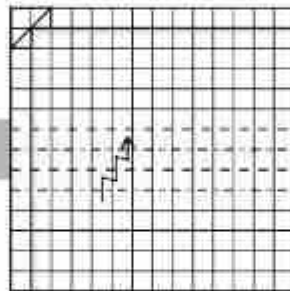

④

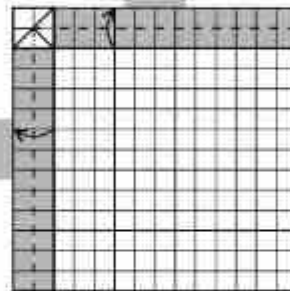

⑦

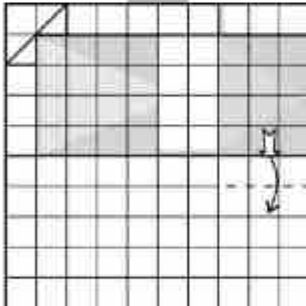

⑧

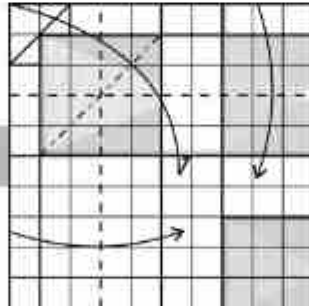

⑨

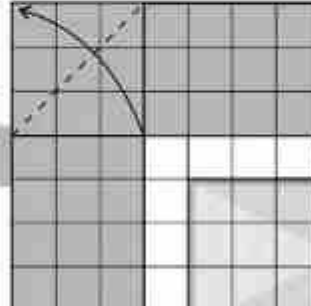

⑫

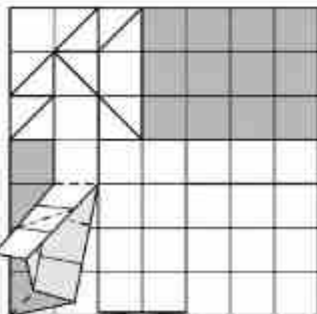

⑪

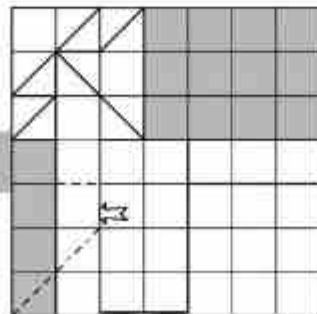

⑩

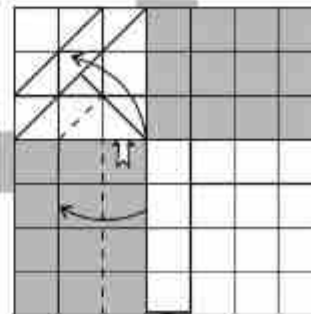

1 lapis saja
1 layer only

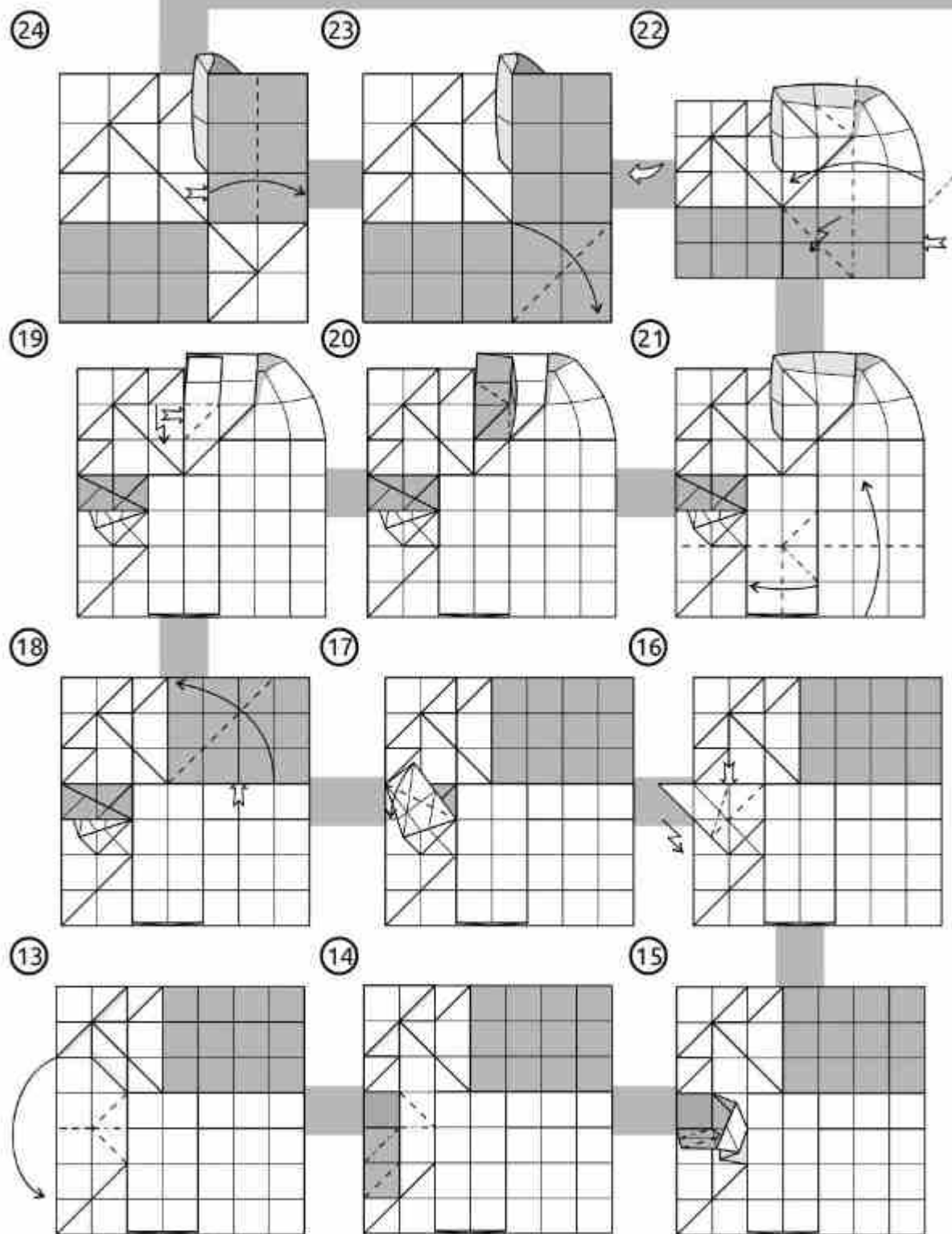

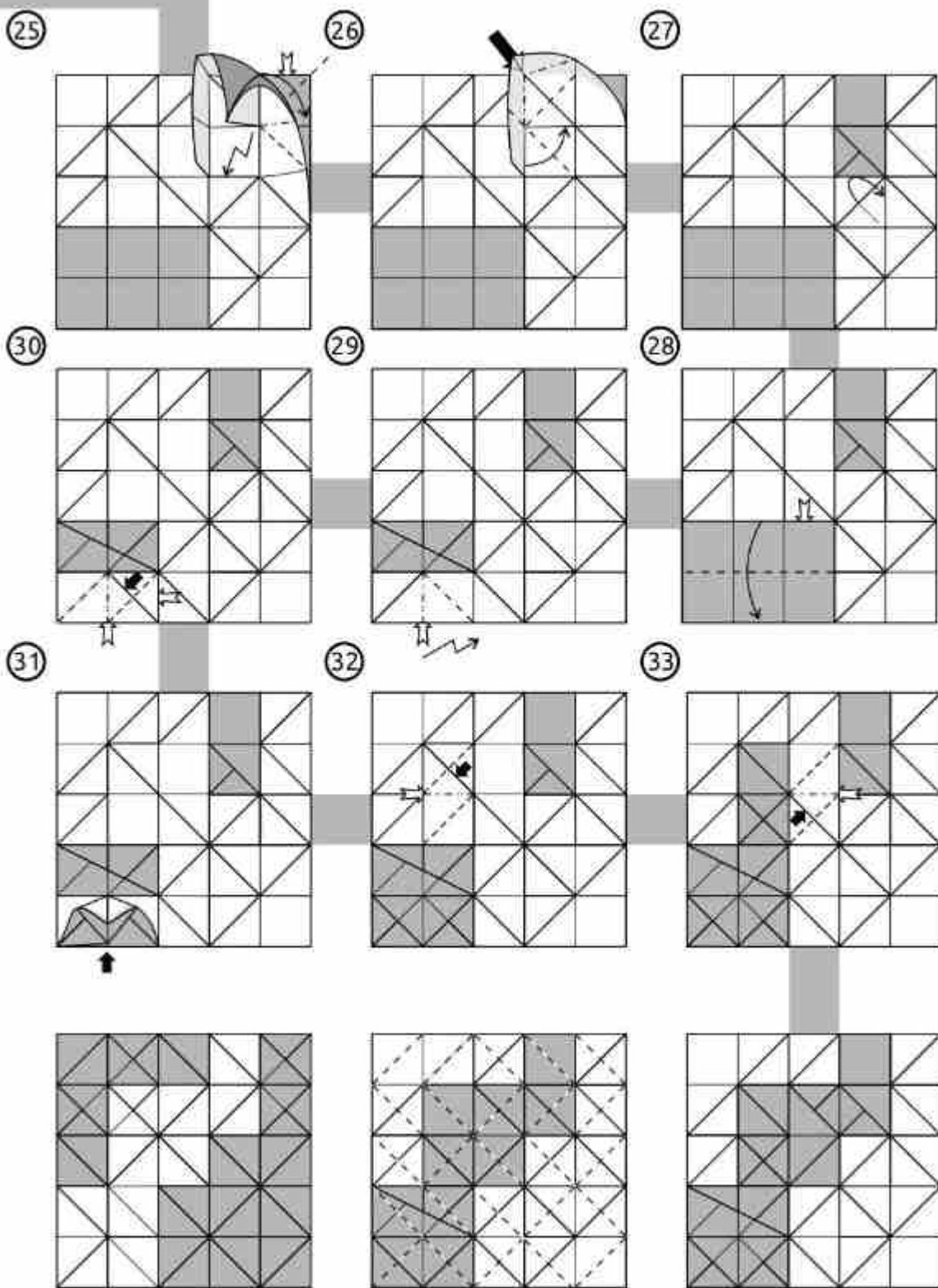

Rabbit

Intermediate

Hadi Tahir

©2014 - Indonesia

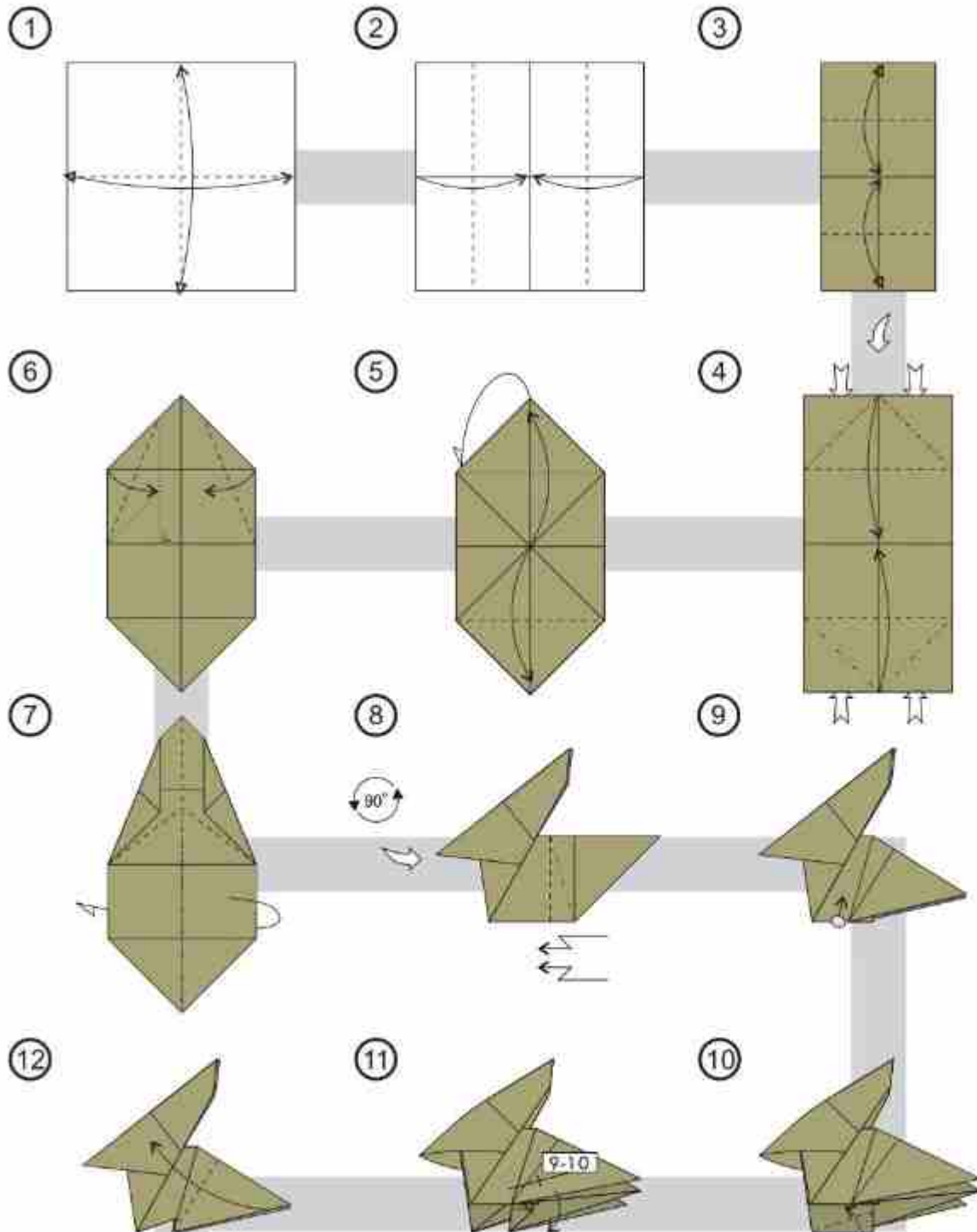

perbandingan ukuran kertas
dan ukuran model jadi

size comparison between
paper and finished model

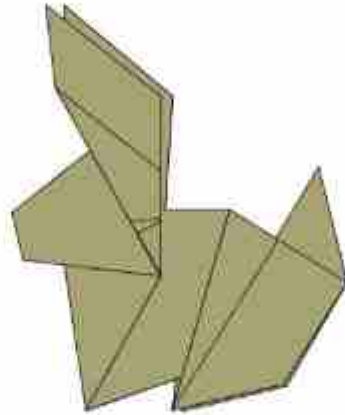
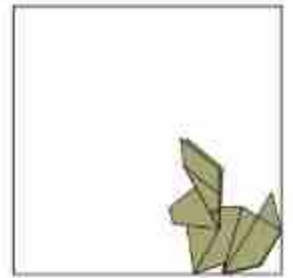

18

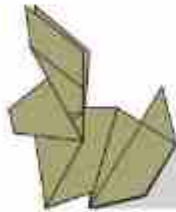

17

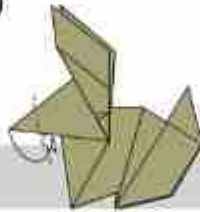

16

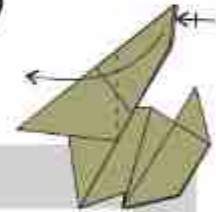

13



14

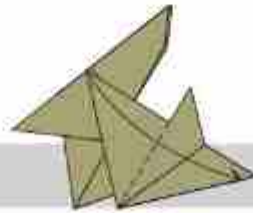

15

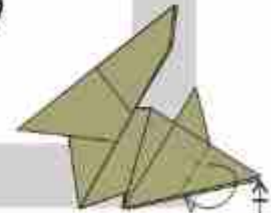

Star

Intermediate

Hadi Tahir

©2021 - Indonesia

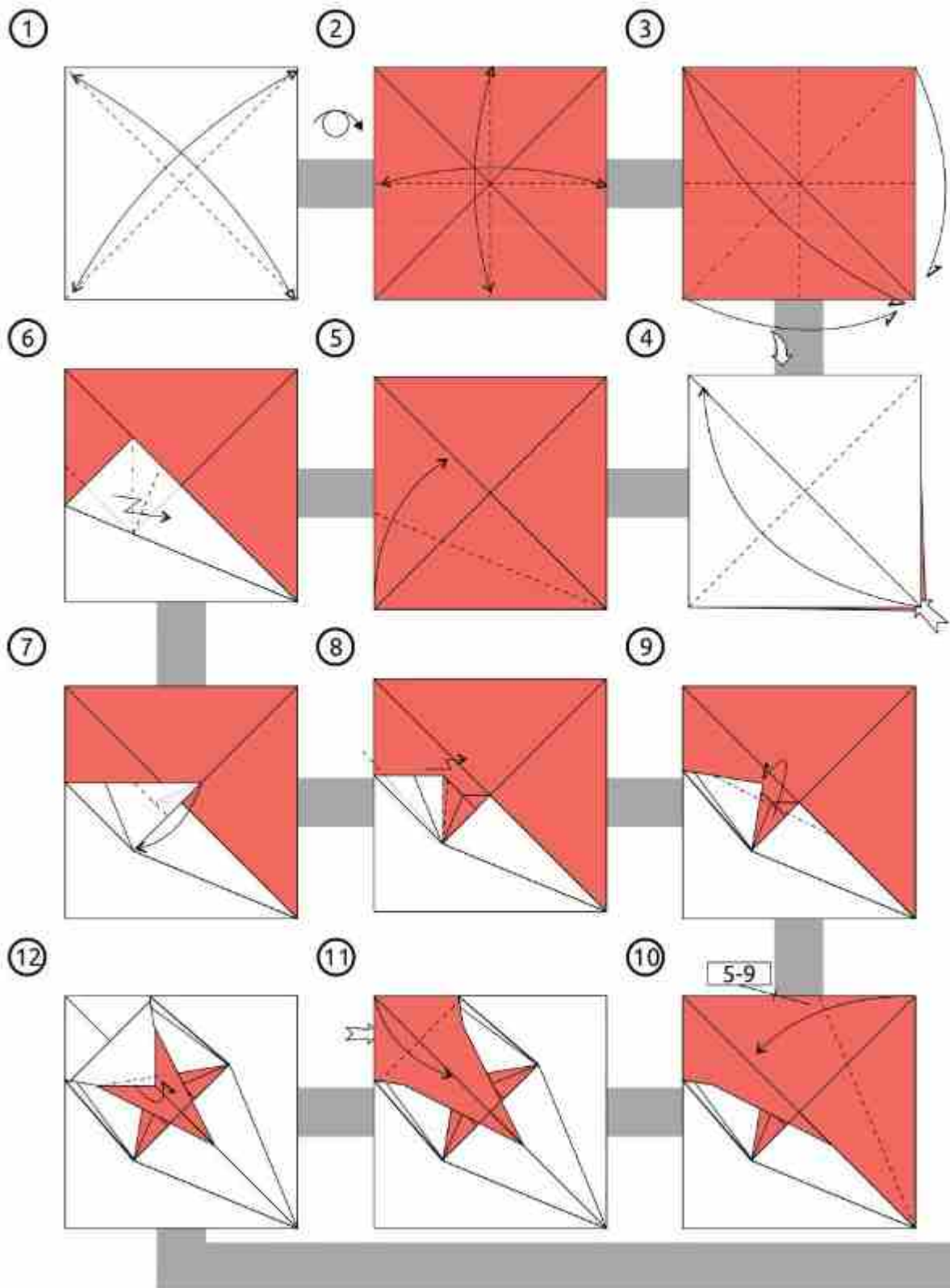

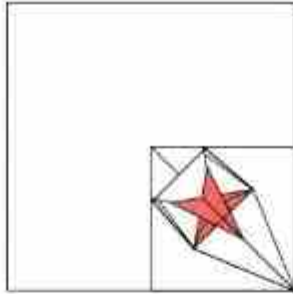

perbandingan ukuran kertas
dan ukuran model jadi

*ratio between the paper size
and finished model size*

使用した紙と完成作品のサイズ比較。

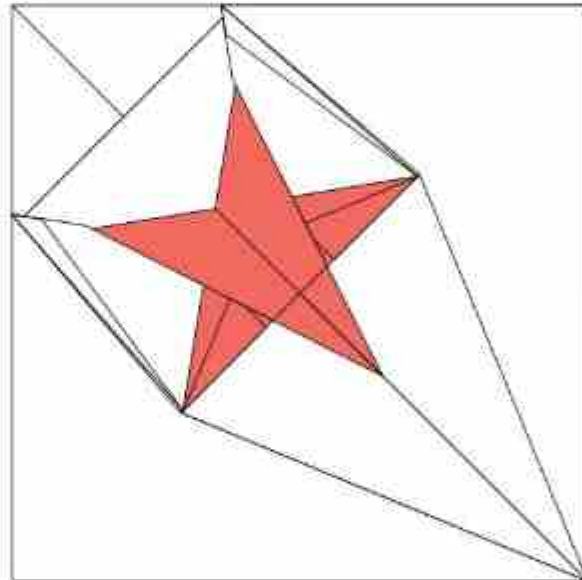

⑬

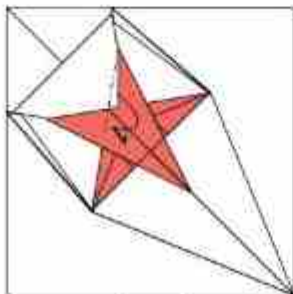

Beaver

High Intermediate

Nicolas Terry

©2022 - France

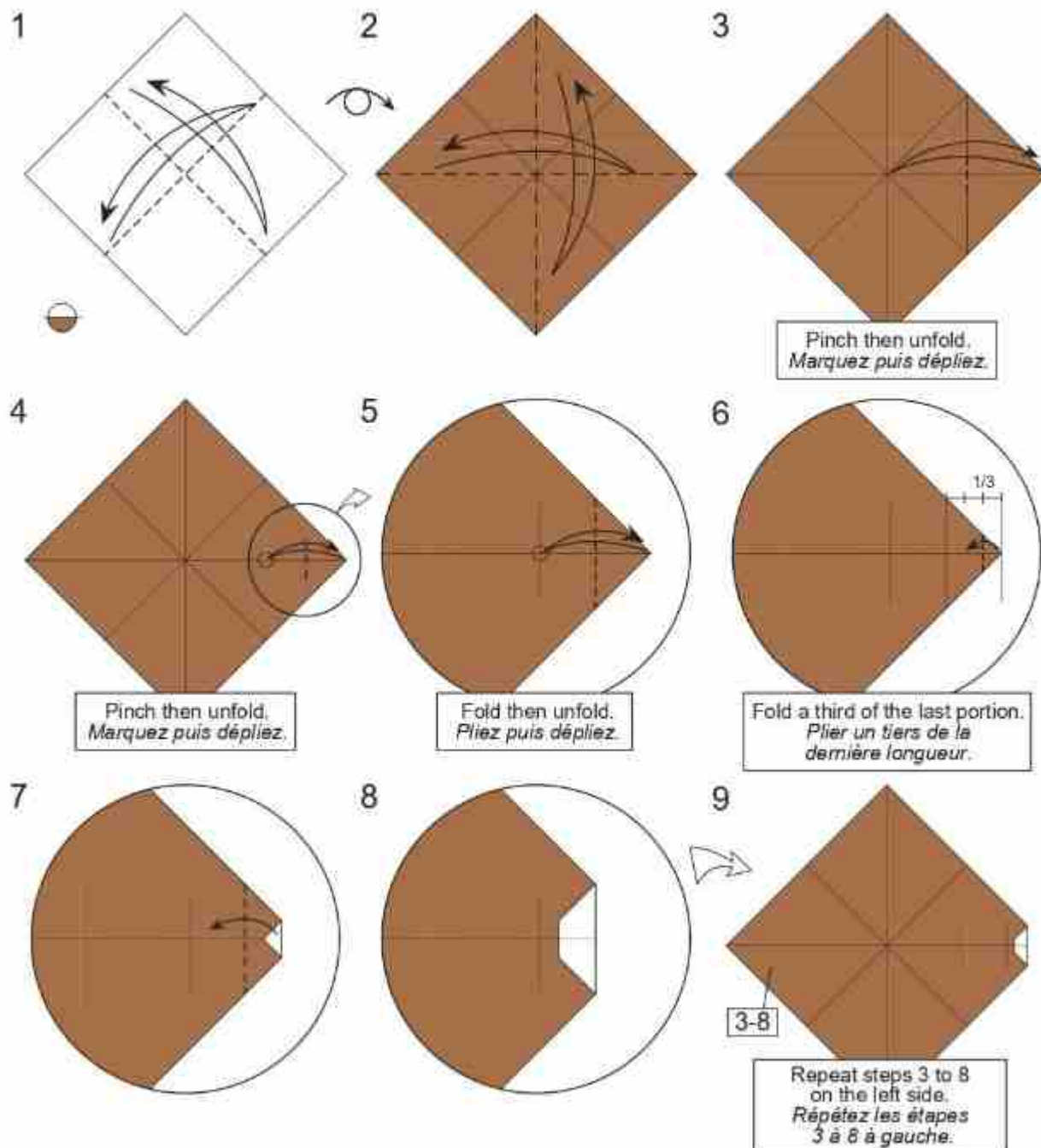

10

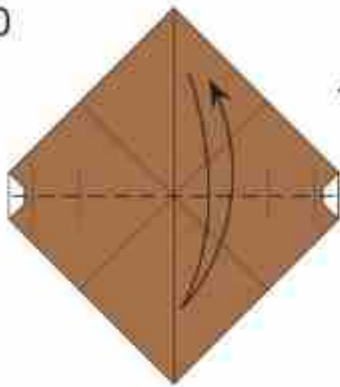

11

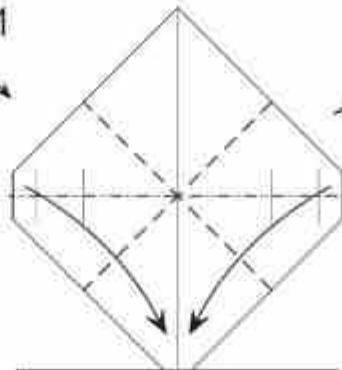

Fold a preliminary base.
Pliez une base préliminaire.

12

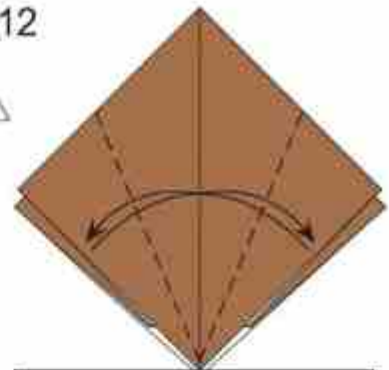

Fold along the angle bisectors.
Pliez selon les bissectrices.

13

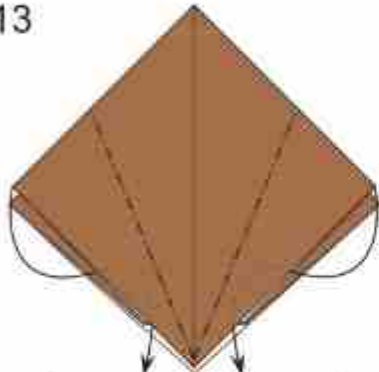

Inside reverse-folds.
Pliés inversés intérieurs.

14

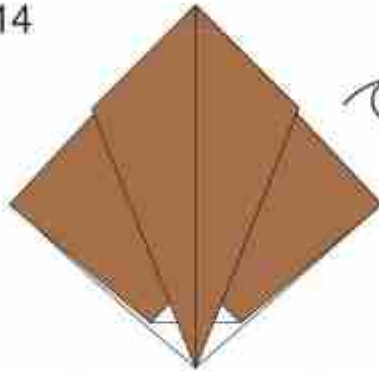

Turn over the model.
Retournez le modèle.

15

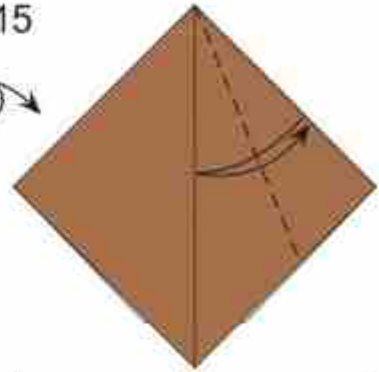

Fold along the angle bisector.
Pliez selon la bissectrice.

16

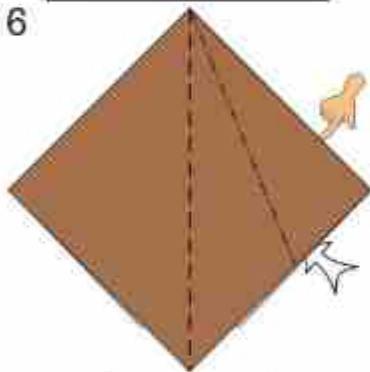

Squash-fold.
Pli aplati.

17



Fold along the angle bisectors.
Pliez selon les bissectrices.

18

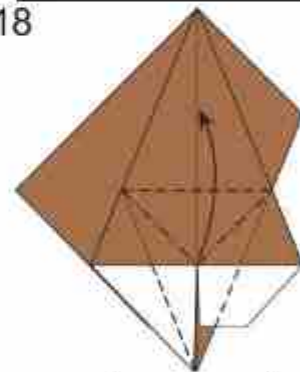

Petal-fold.
Pli pétale.

19

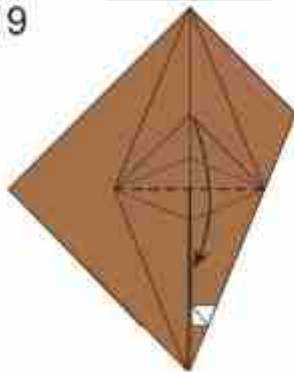

20

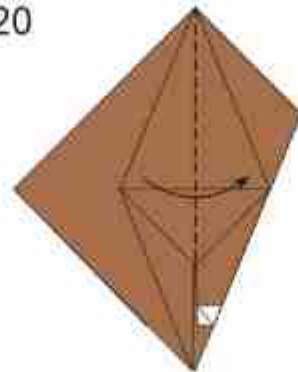

21

15-20

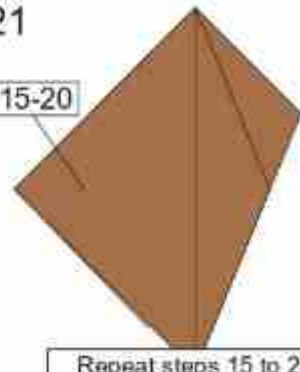

Repeat steps 15 to 20
on the left side.
*Répétez les étapes
15 à 20 à gauche.*

22



23

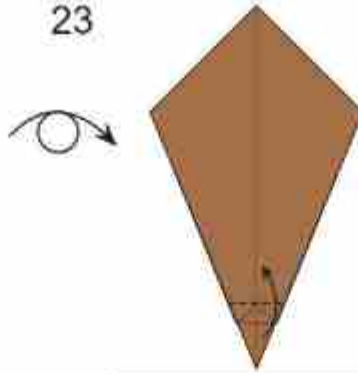

24

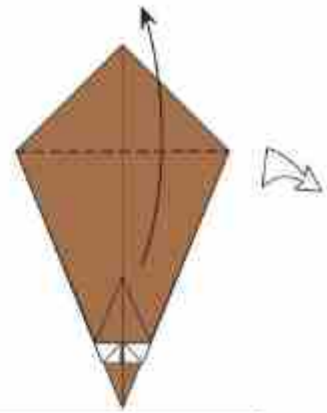

Use the hidden white flaps as a reference for this fold.
Utilisez les volets blancs cachés comme référence pour ce pli.

25

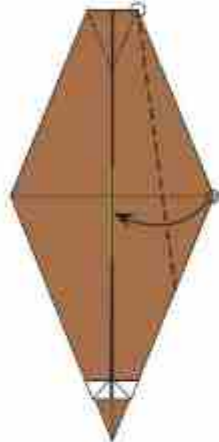

26

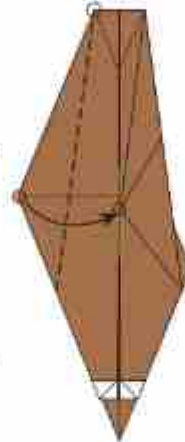

Bring the red corner to the green center line.
Amenez le coin rouge sur l'axe central vert.

27

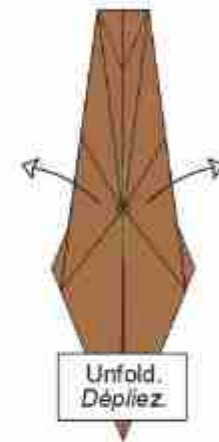

Unfold.
Dépliez.

28

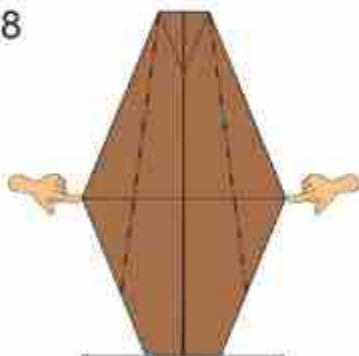

Open sinks.
Enfoncements ouverts.

29

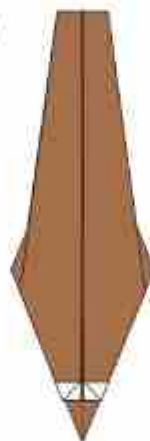

30

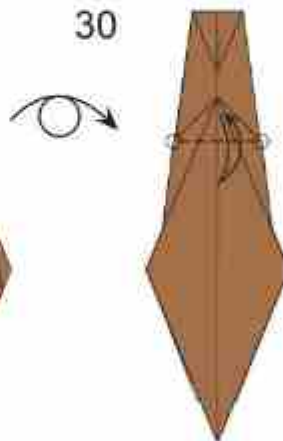

31

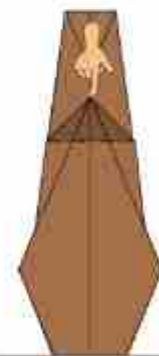

Complex open sink.
Enfoncement ouvert complexe.

32

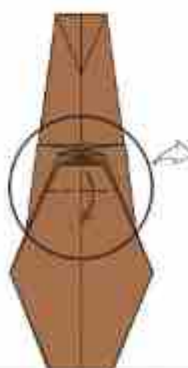

33

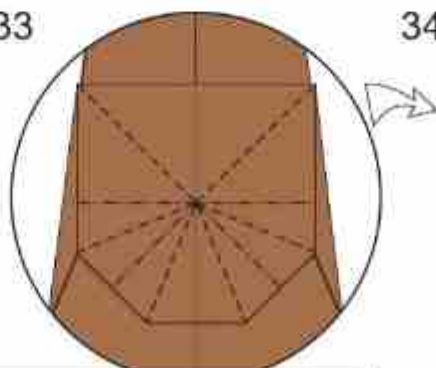

34



Open sink completely, check creases are as shown and collapse.
Avant de l'aplatir, ouvrez-le complètement pour vous assurer que chaque pli a été correctement réalisé. Ensuite, repliez en suivant les plis.

35

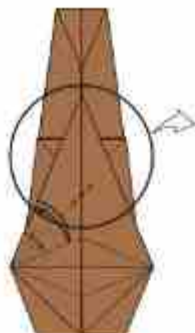

Mark the bisector at
the intersection of the axis.
*Marquez la bissectrice
au croisement de l'axe.*

36

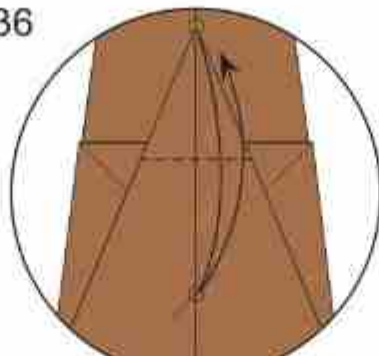

Fold then unfold.
Pliez puis dépliez.

37

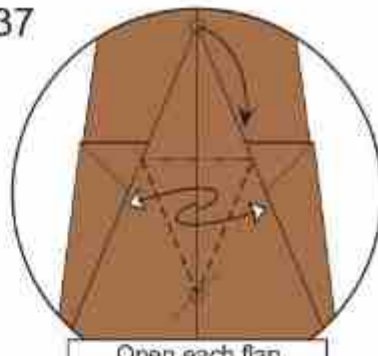

Open each flap
and lower the tip.
*Ouvrez chaque volet
et abaissez la pointe.*

38

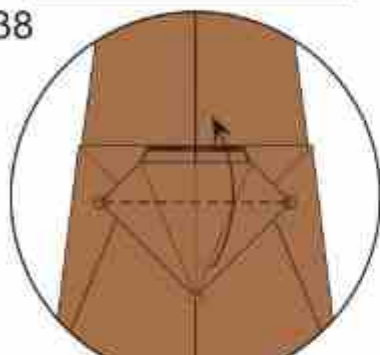

Note the references to fold the tip.
Notez les références pour ce pli.

39

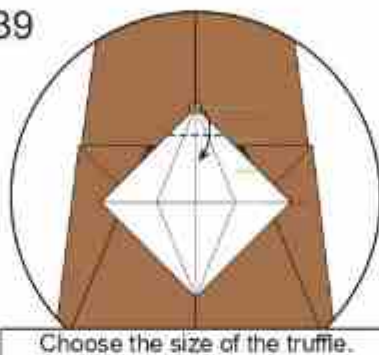

Choose the size of the truffle.
There is no precise reference.
*Choisissez la grosseur de la truffe.
Il n'y a pas de référence précise.*

40

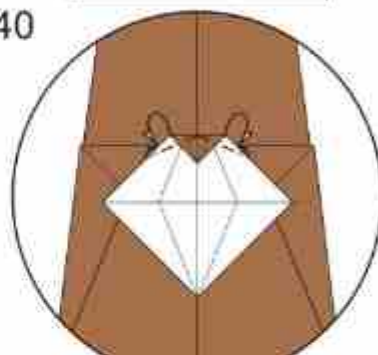

41

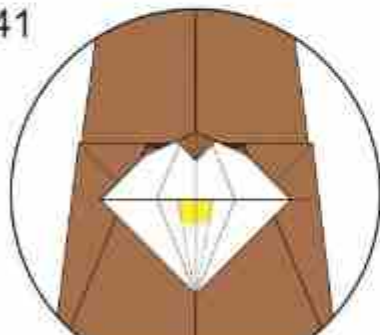

View the desired size for the teeth.
*Visualisez la taille souhaitée
pour les dents.*

42



You can also split
the angle in 5.
*Vous pouvez aussi
partager l'angle en 5.*

Or use these references.
Ou utilisez ces références.

43

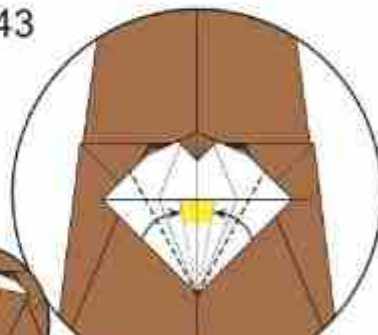

Fold each side "against"
the edge of the teeth.
*Pliez chaque côté "contre"
le bord des dents.*

44

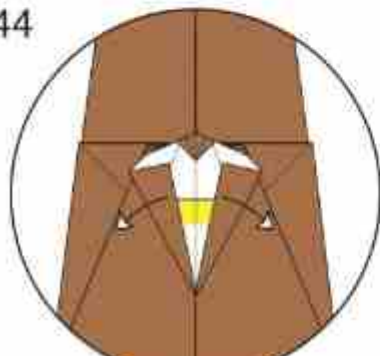

Unfold.
Dépliez.

45

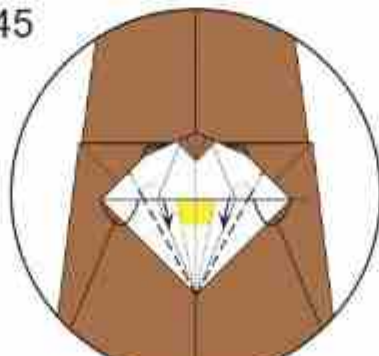

Inside reverse-folds.
Plis inversés intérieurs.

46

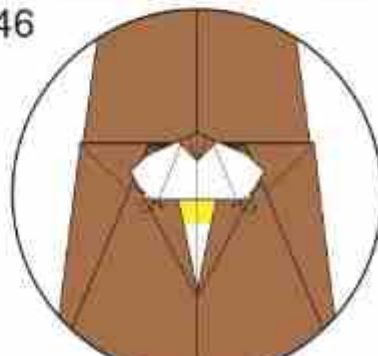

Shape the muzzle.
Modelez le museau.

47

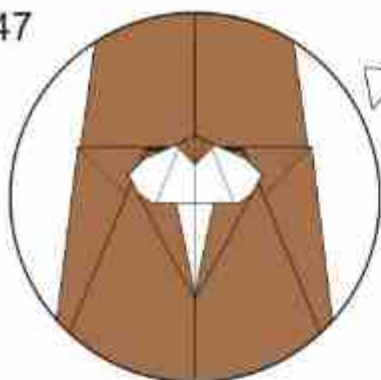

48

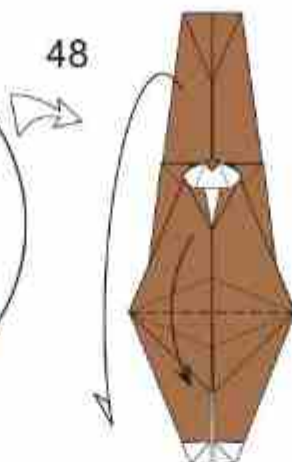

Lower the
front and
back flaps.
*Abaissez
les volets
de devant
et derrière.*

49

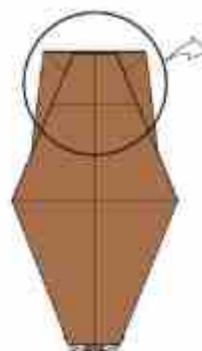

50

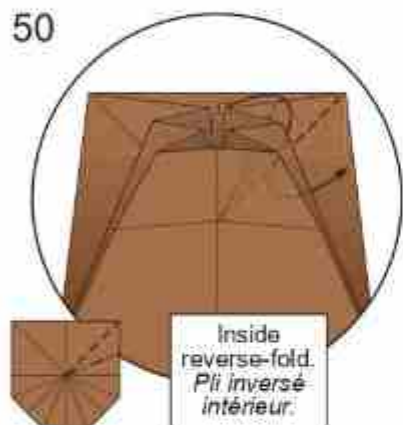

Inside
reverse-fold.
*Pli inversé
intérieur.*

51

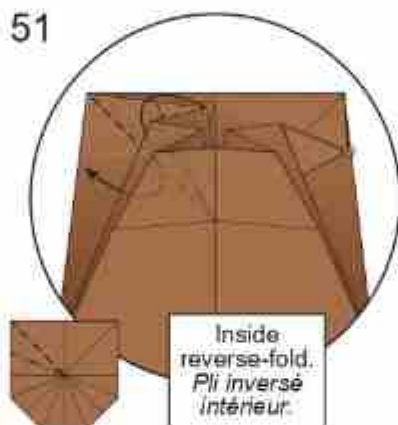

Inside
reverse-fold.
*Pli inversé
intérieur.*

52

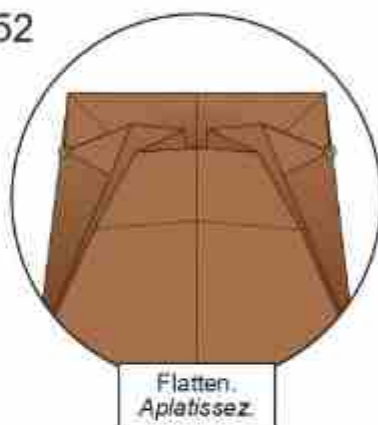

Flatten.
Aplatissez.

53

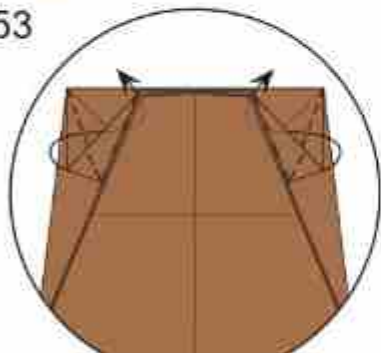

Inside reverse-folds.
Plis inversés intérieurs.

54

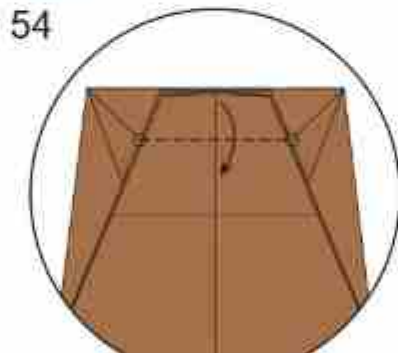

Valley-fold the layers together.
Pliez les couches ensemble.

55

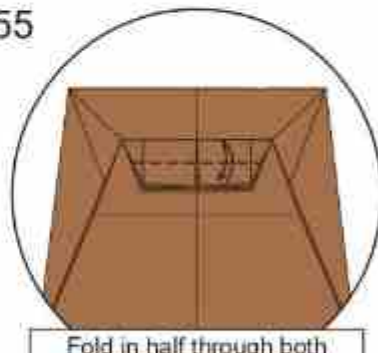

Fold in half through both
layers then unfold.
*Pliez en deux à travers les
deux couches puis dépliez.*

56

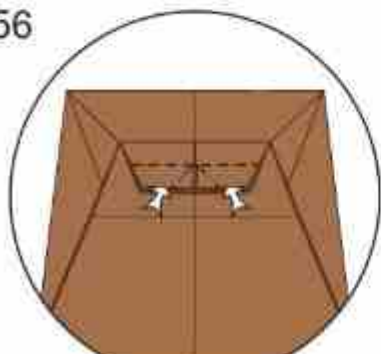

Squash-folds.
Plis aplatis.

57

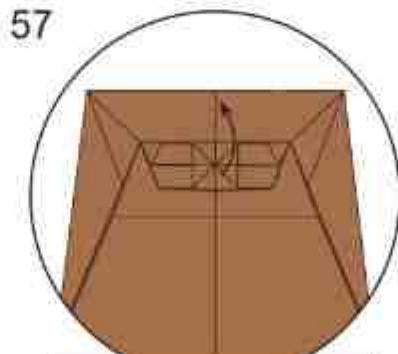

Fold up the group of layers.
*Pliez vers le haut le
groupe de couches.*

58

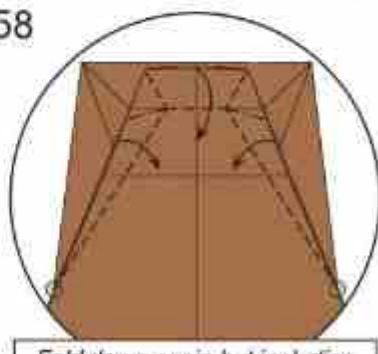

Fold down again but including
these 2 reverse-folds.
*Repliez à nouveau mais en
incluant ces 2 plis inversés.*

59

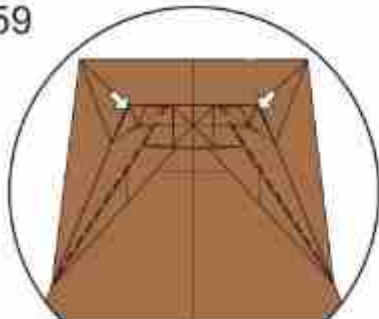

Optional: Swivel-fold the second layer.
Facultatif : Pli pivot sur la deuxième couche.

60

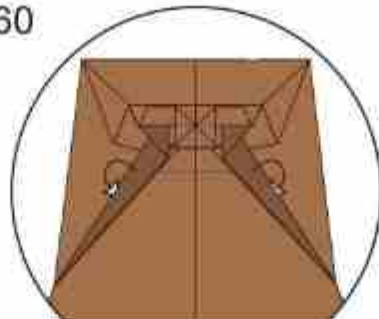

Hide the shaded flaps behind.
Cachez les volets grisés derrière.

61

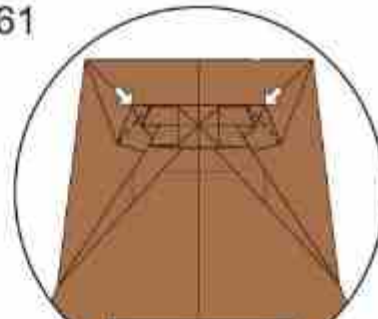

Inside reverse-folds.
Plis inversés intérieurs.

62

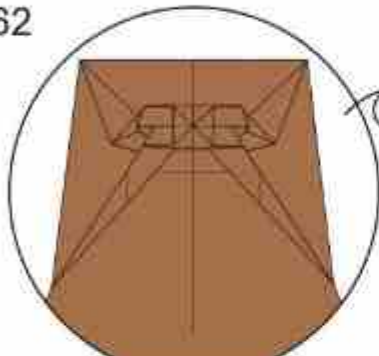

Turn over the model.
Retournez le modèle.

63

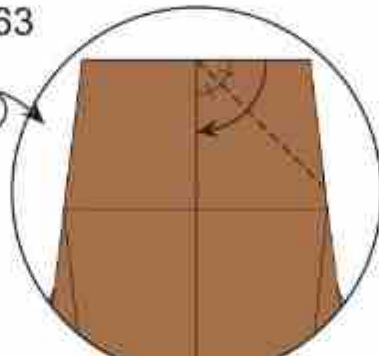

Fold along the angle bisector.
Pliez selon la bissectrice.

64

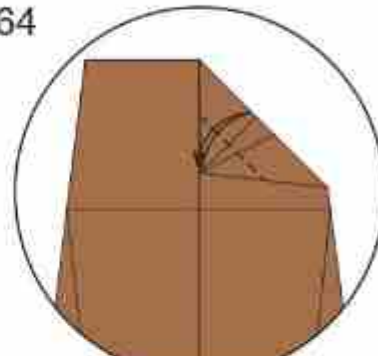

Fold then unfold.
Pliez puis dépliez.

65

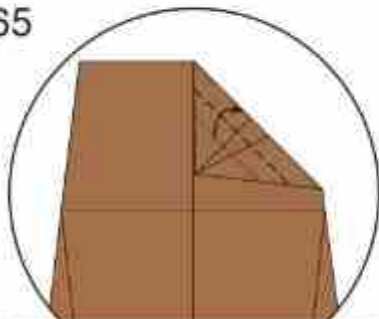

Fold in half from the fold made in the previous step.
Pliez en deux à partir du pli réalisé à l'étape précédente.

66

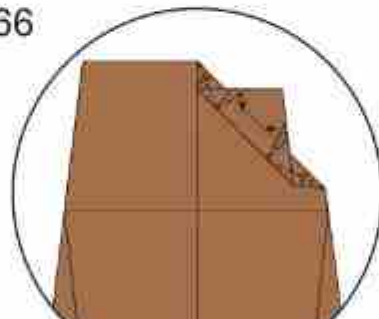

Swivel-folds to shape the ear.
Plis pivot pour modeler l'oreille.

67

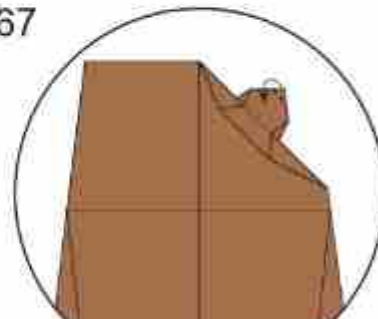

Round the tip of the ear.
Arrondissez la pointe de l'oreille.

68

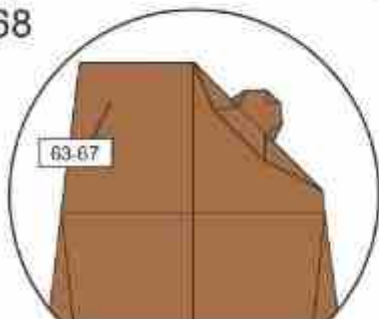

Repeat steps 63 to 67 on the left side.
Répétez les étapes 63 à 67 à gauche.

69

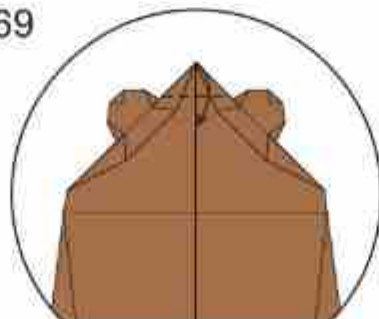

Fold down the tip to round the head.
Pliez la pointe pour arrondir la tête.

70

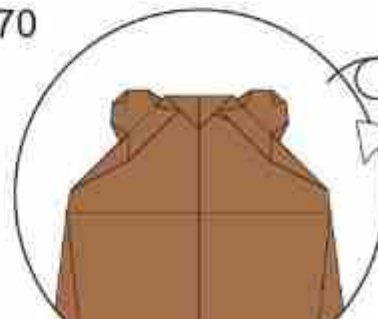

Turn over the model.
Retournez le modèle.

71

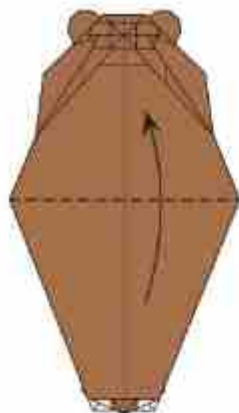

72



View the desired size for the teeth.
Visualisez la taille souhaitée pour les dents.

73

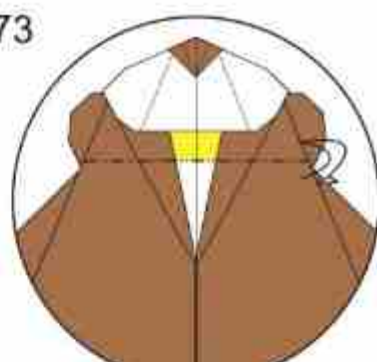

Mountain-fold then unfold.
Pli montagne puis dépliez.

74

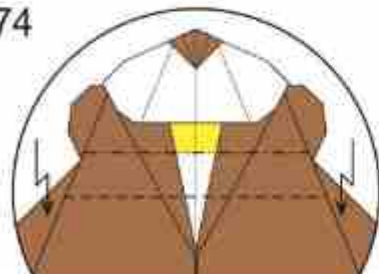

Pleat-fold. Find the location of the valley fold with the reference shown in the next step.
Repli. Trouvez la localisation du pli vallée avec la référence montrée à l'étape suivante.

75

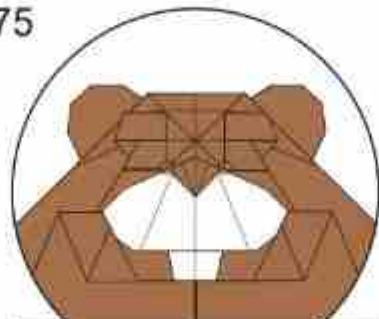

Check the position of the muzzle in relation to the eyes.
Vérifiez la position du museau par rapport aux yeux.

76

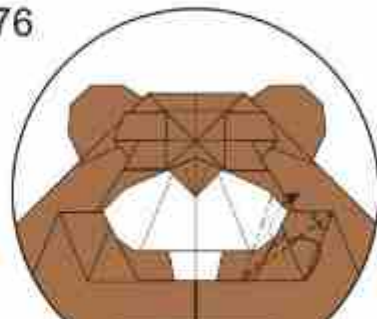

Inside reverse-fold.
Pli inversé intérieur.

77

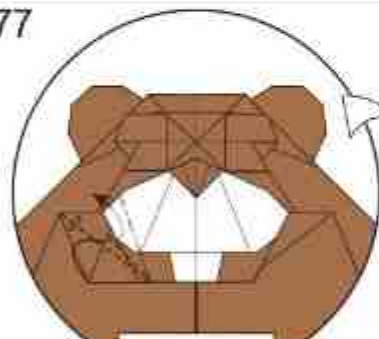

Inside reverse-fold.
Pli inversé intérieur.

78

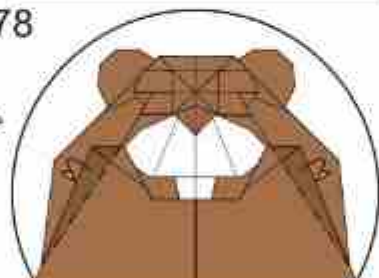

Fold the shaded areas into the pocket right behind to lock the muzzle against the eyes.
Pliez dans la pochette située juste derrière pour bloquer le museau contre les yeux.

79

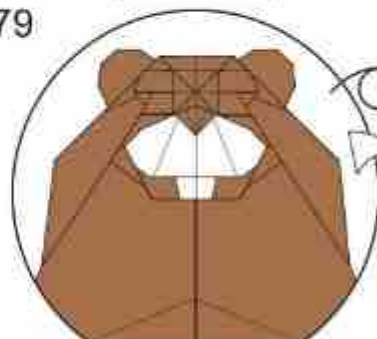

Turn over the model.
Retournez le modèle.

80



81



82

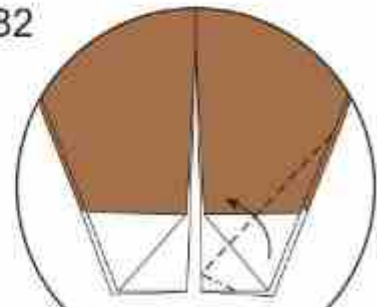

Squash-fold.
Pli aplati.

83

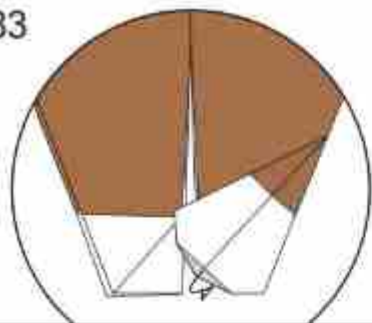

Optional: unwrap the small shaded triangle to hide it behind.
Facultatif : déroulez le petit triangle grisé pour le cacher derrière.

84

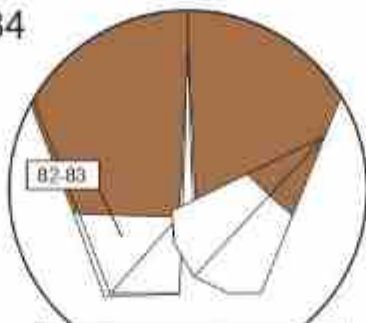

Repeat steps 82 & 83 on the left side.
Répétez les étapes 82 et 83 à gauche.

85

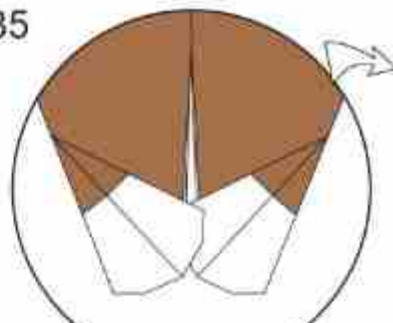

Hands complete.
Mains terminées.

86



Swivel-fold and flatten.
Pli pivot et aplatissez.

87

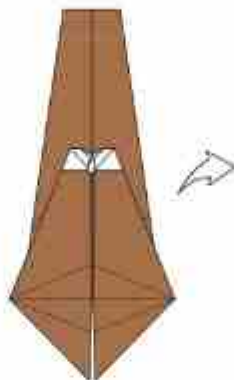

90

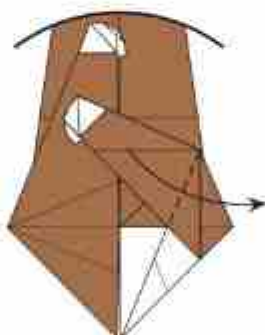

Fold the arm to the right.
Pliez le bras à droite.

88

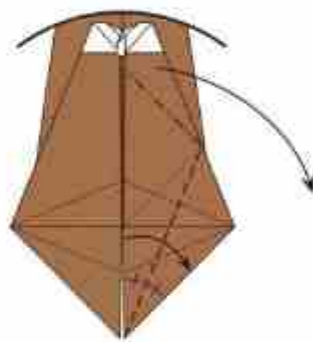

Swivel-fold and flatten.
Pli pivot et aplatissez.

91

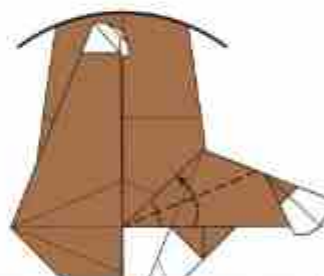

Fold ONLY TWO layers. The arm opens partially and is no longer flat.
Pliez SEULEMENT DEUX couches. Le bras s'ouvre partiellement et n'est plus plat.

92

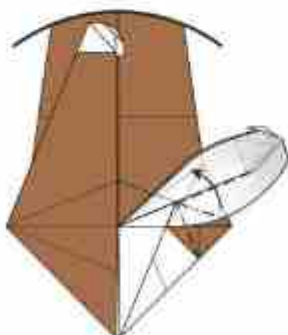

Close the arm with a swivel-fold.
Fermez le bras avec un pli pivot.

93

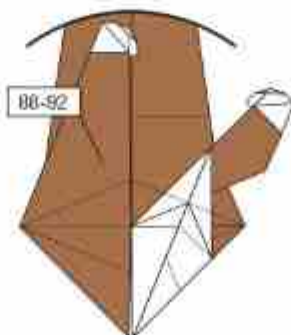

Repeat steps 88 & 92 on the left side.
Répétez les étapes 88 et 92 à gauche.

94

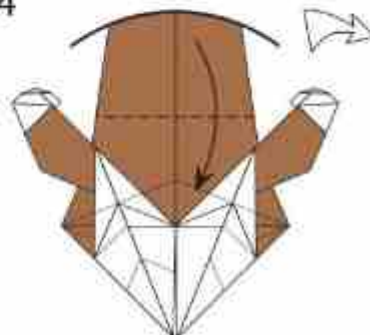

Fold the tail down.
Pliez la queue vers le bas.

95



96

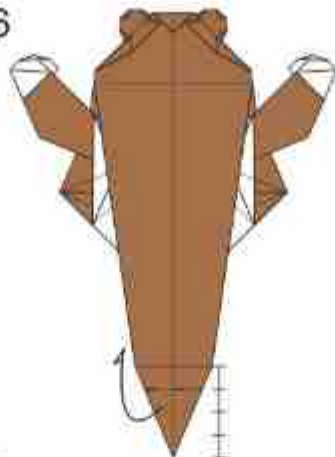

97

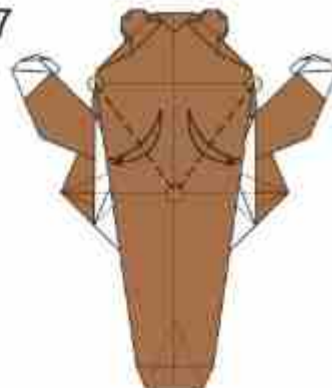

98

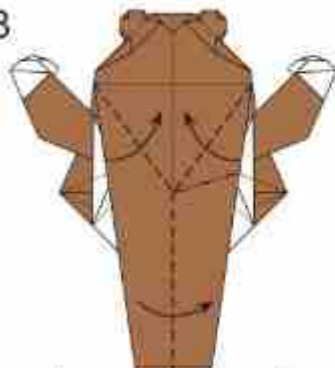

Rabbit-ear fold.
Pli oreille de lapin.

99

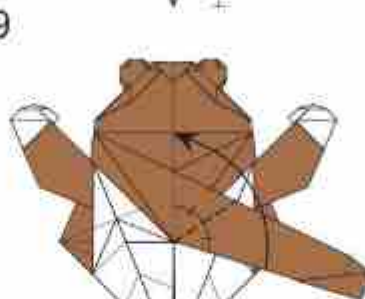

Fold along the angle bisector.
Pliez selon la bissectrice.

100

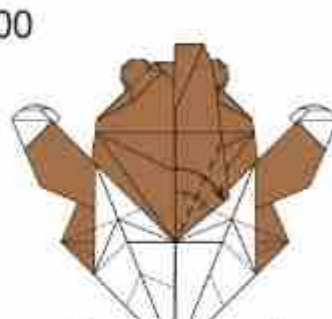

Fold along the angle bisector.
Pliez selon la bissectrice.

101

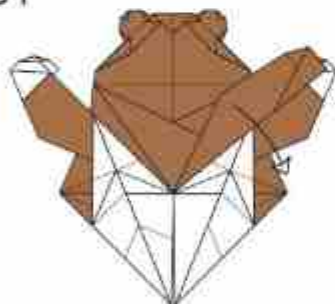

Unfold.
Dépliez.

102

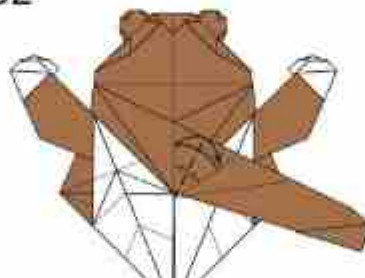

Fold along the angle bisector through all layers.
Pliez selon la bissectrice à travers toutes les couches.

103

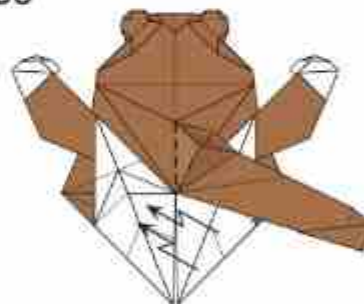

Crimp fold.
Double repli.

104

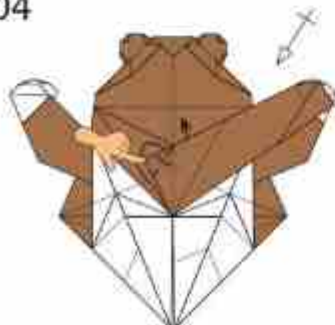

Inside reverse-fold along the angle bisector. Repeat on the right.
Pli inversé intérieur le long de la bissectrice. Répétez à droite.

105

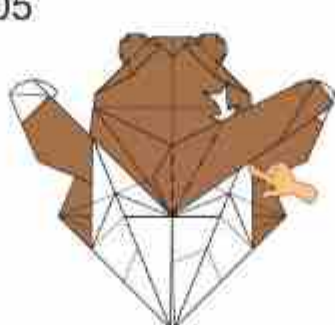

Squash-fold.
Pli aplati.

106

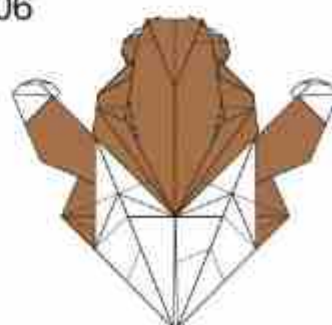

Shape the tail.
Modelez la queue.

107

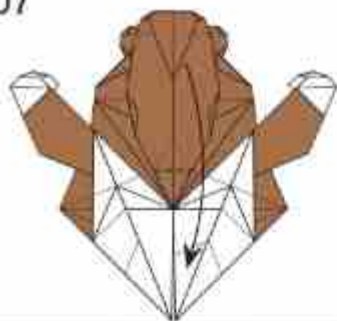

Fold the tail as far as possible.
Pliez la queue aussi loin que possible.

108

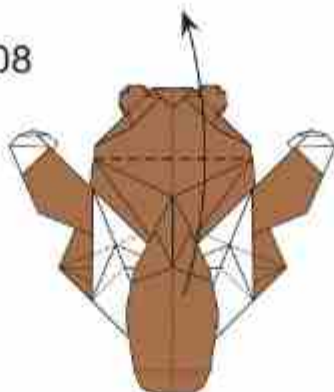

Fold up the tail.
Pliez la queue vers le haut.

109

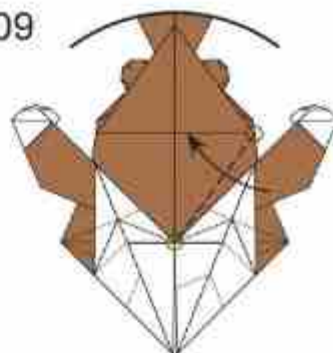

Fold through all layers.
Pliez à travers toutes les couches.

110

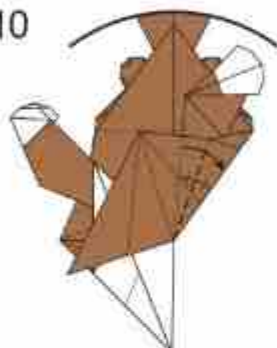

Fold along the angle bisector.
Pliez selon la bissectrice.

111

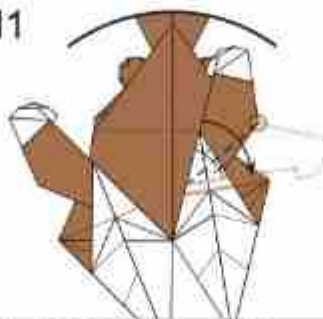

Fold along the angle bisector using a parallel to the red line.
Pliez la bissectrice en utilisant une parallèle à la ligne rouge.

112

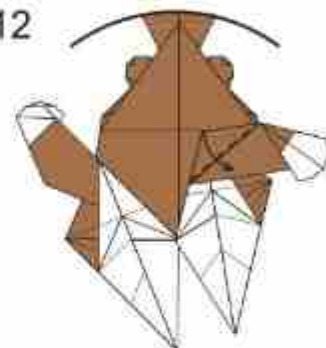

Valley-fold
Pli vallée.

113

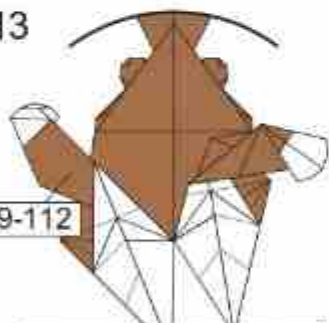

Repeat steps 109 to 112 on the left side.
Répétez les étapes 109 à 112 à gauche.

114

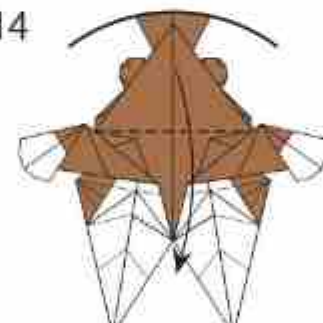

Valley-fold down the tail.
Pliez la queue vers le bas.

115

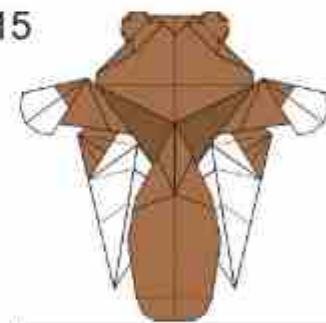

Insert the shaded flaps behind the arms.
Insérez les volets grisés derrière les volets des bras.

116

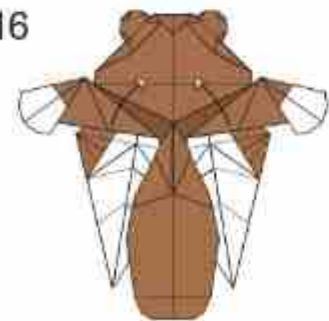

Unfold the flaps folded in step 112.
Dépliez les volets pliés à l'étape 112.

117

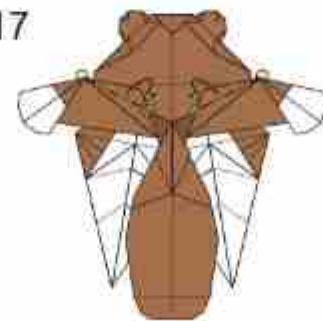

Lock the arms inserting the flaps behind the shaded flaps.
Verrouillez les bras en insérant les volets derrière les volets grisés.

118

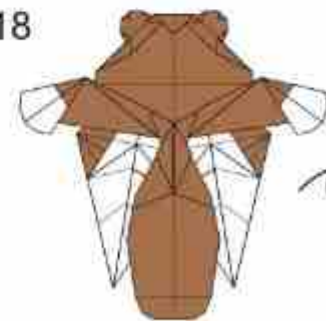

Turn over the model.
Retournez le modèle.

119

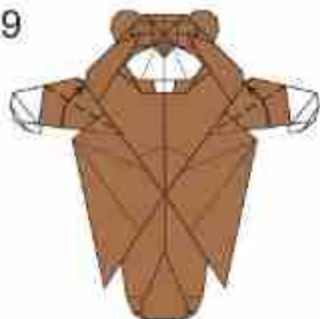

Valley-fold the arms.
Pli vallée des bras.

120

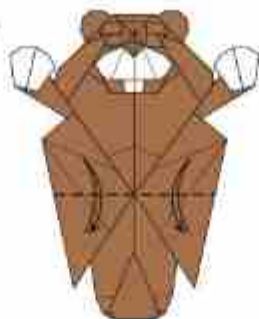

Valley-fold horizontally then unfold.
Pliez à l'horizontal puis dépliez.

121

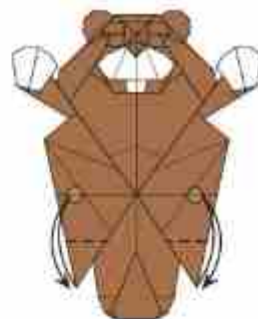

Valley-fold the feet.
Pliez le bout des pattes.

122

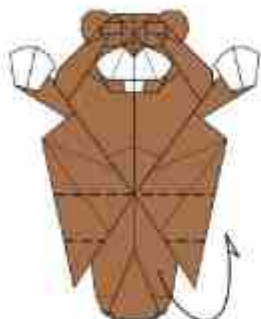

Move into a sitting position
by folding the legs and tail at 90°.
*Passez en position assise en
pliant à 90° les pattes et la queue.*

123



Round out the thighs and
fold the tips of the legs.
*Arrondissez les cuisses
et pliez le bout des pattes.*

124

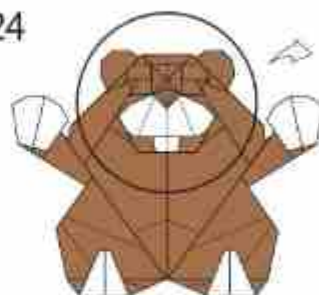

Focus on the head.
Zoom sur la tête.

125

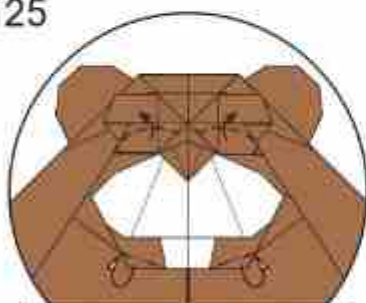

Partially raise the flaps
to create the eyes.
*Levez partiellement les
volets pour créer les yeux.*

126

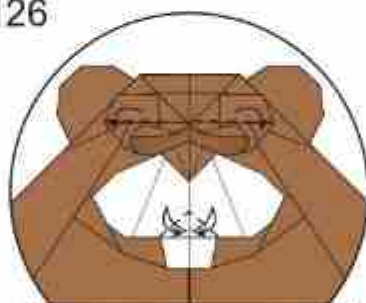

Shape the eyebrows. Fold
the muzzle then unfold.
*Formez les sourcils. Pliez
le museau puis dépliez.*

127

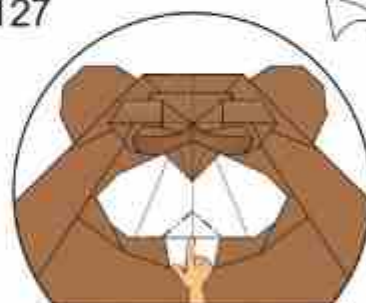

Push in a little to
shape the muzzle in 3D.
*Enfoncez un peu pour
former un museau en 3D.*

128



Optional because difficult:
Create a neck with a partial
pleat-fold through all layers.
*Facultatif car difficile : Créez
un cou avec un repli partiel à
travers toutes les couches.*

129

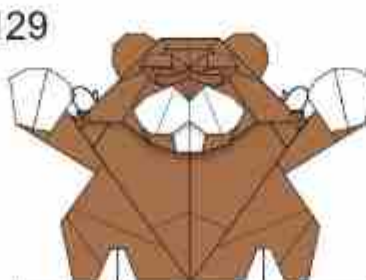

The pleat-fold is just to
create a shadow. Hide the
excess of the sides behind.
*Le repli sert juste à créer
une ombre. Cacher le
surplus des côtés derrière.*

130



Complete!
Terminé !

Puppy

High Intermediate

Ramon Thomas

©2022 - Spain

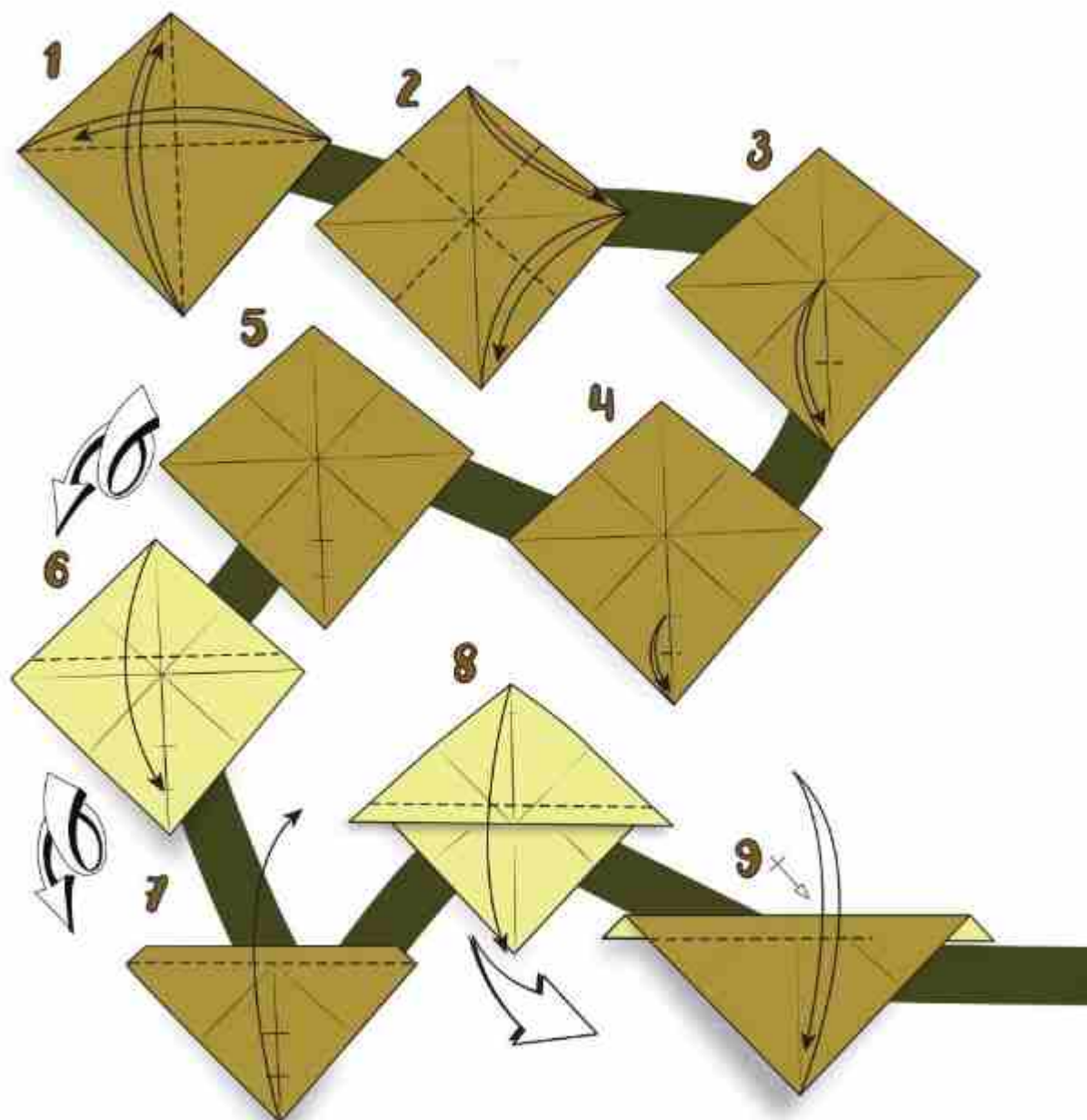

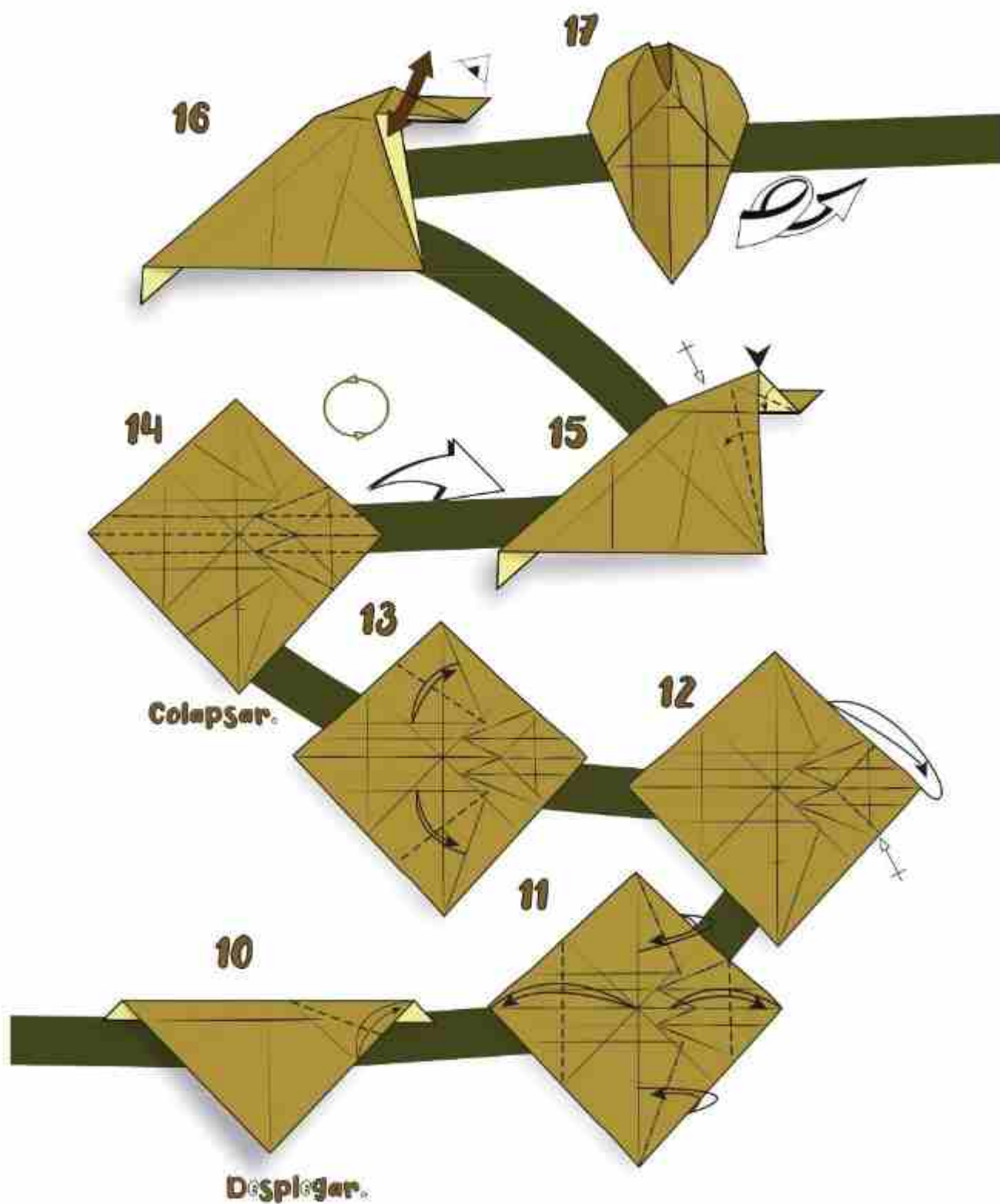

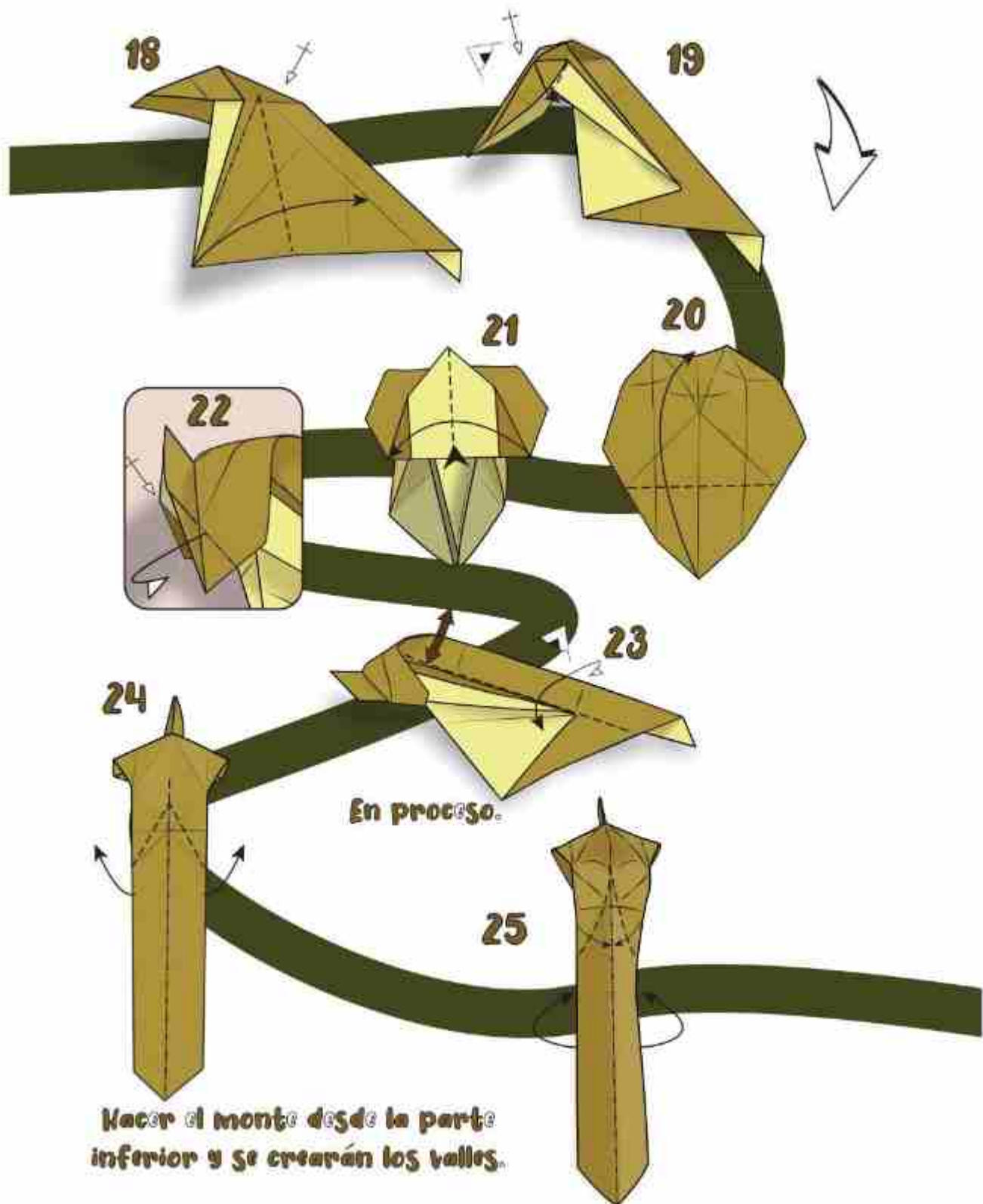

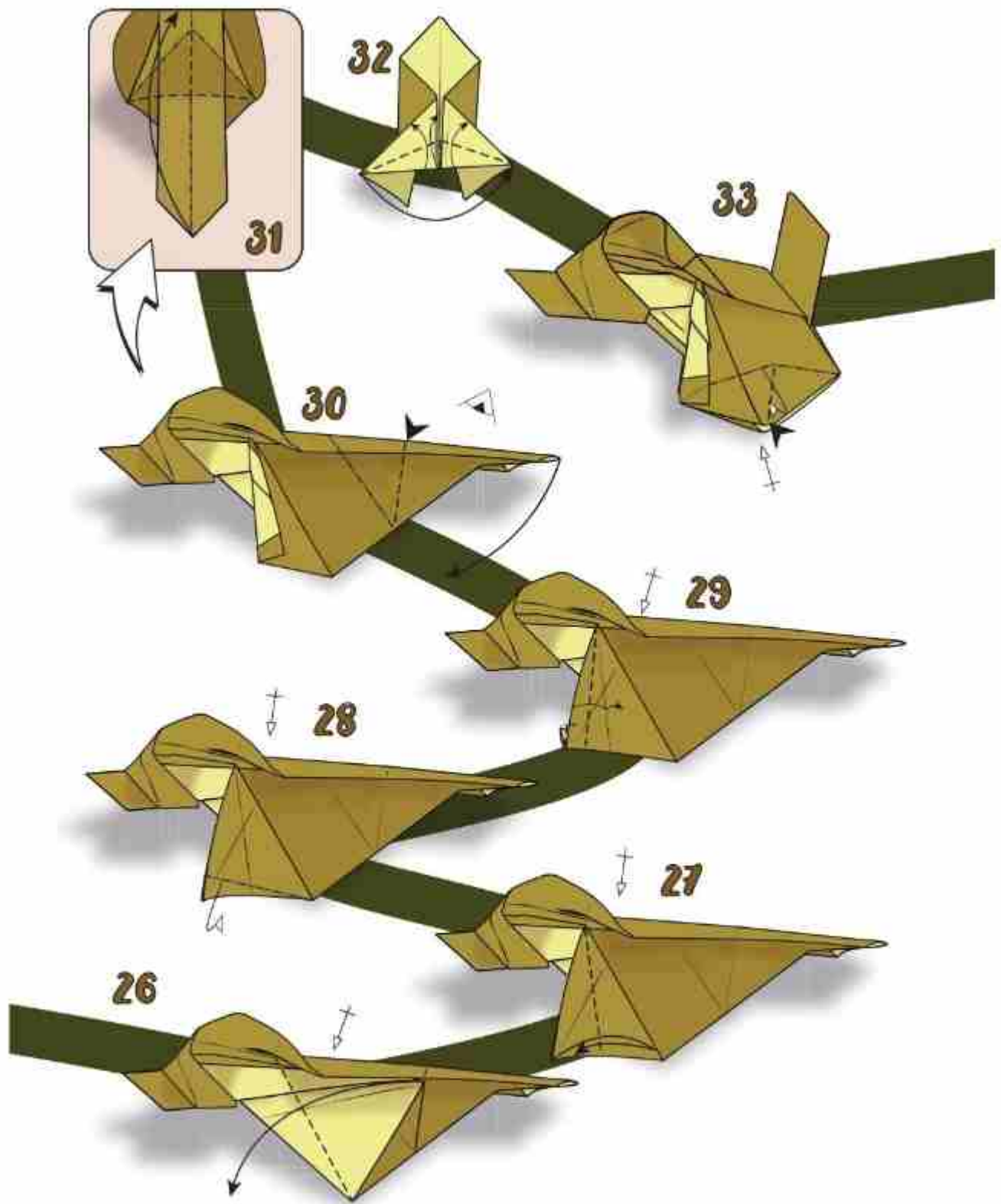

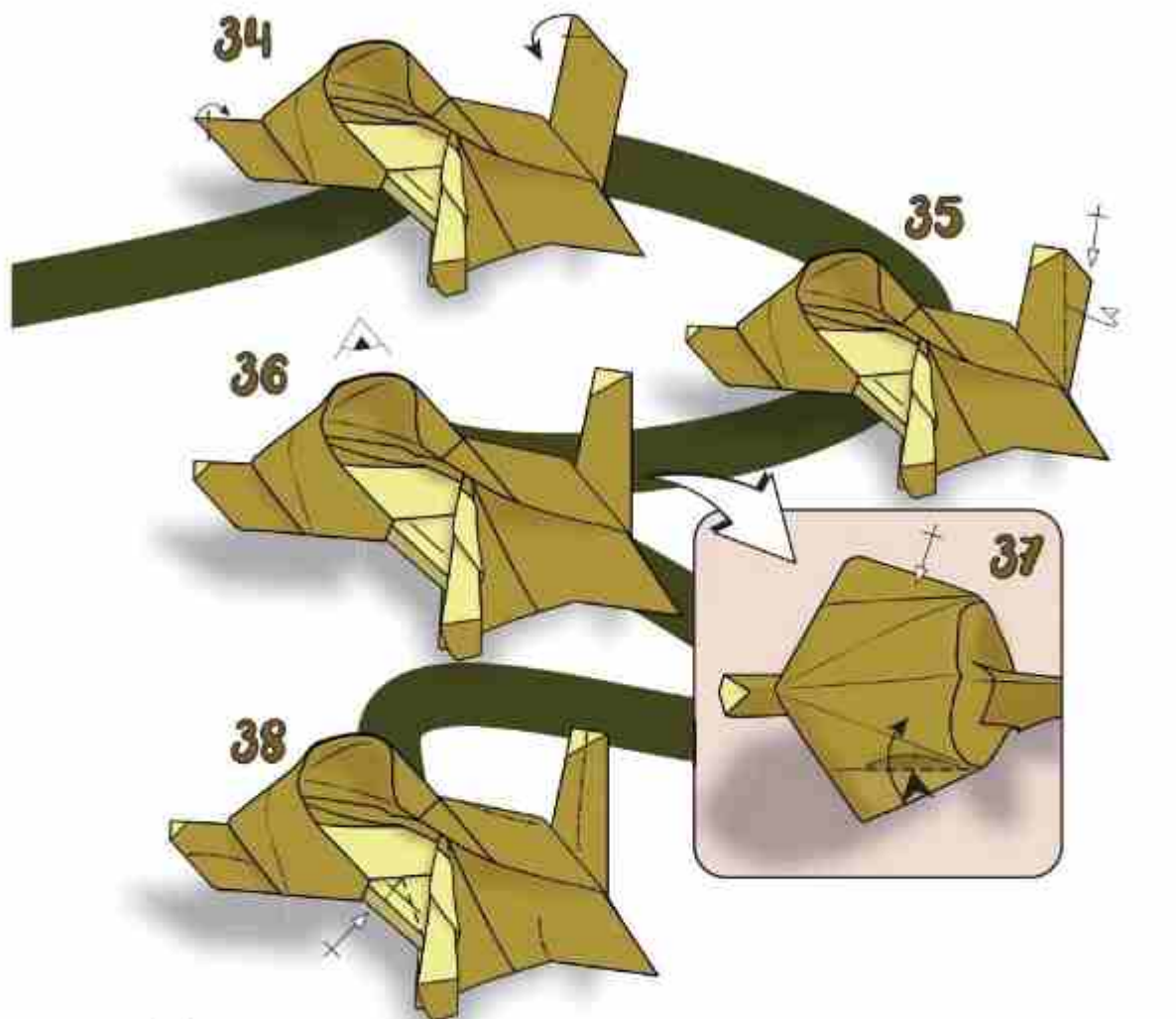

**Hacer un pequeño
crimp y modelar.**

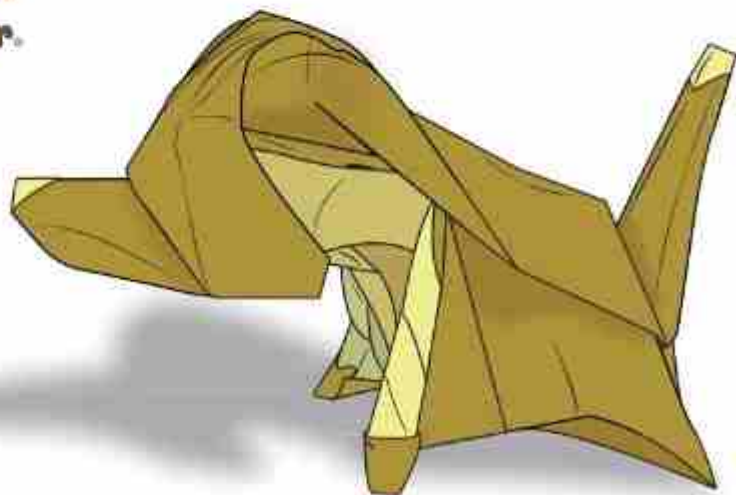

Freedom

Paula Versnick

©2020 - Netherlands

Intermediate

Suggested paper:

Not too slippery (it keeps together by tension)

Three the same 6 inch squares, duo color gives a nice effect.

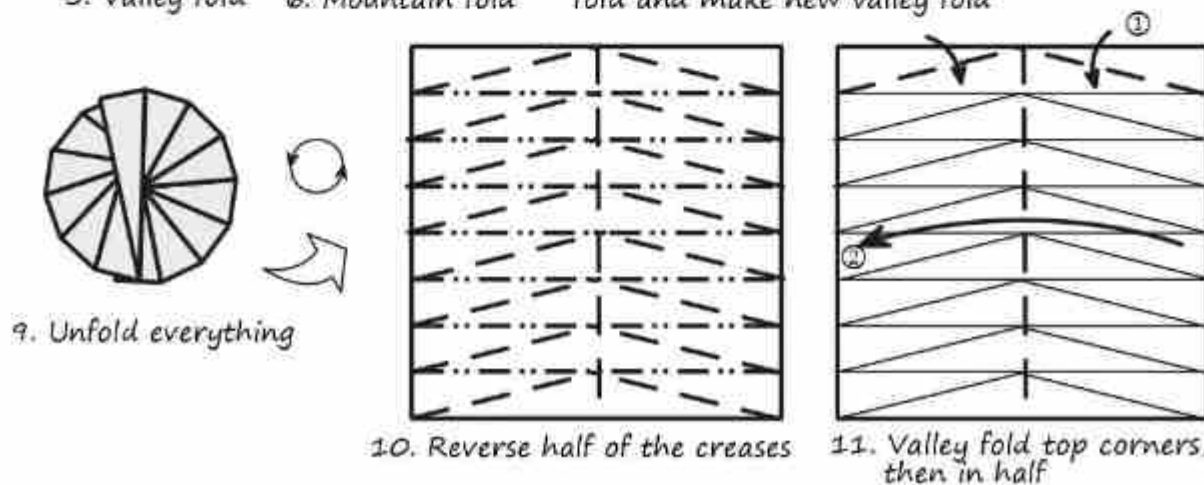
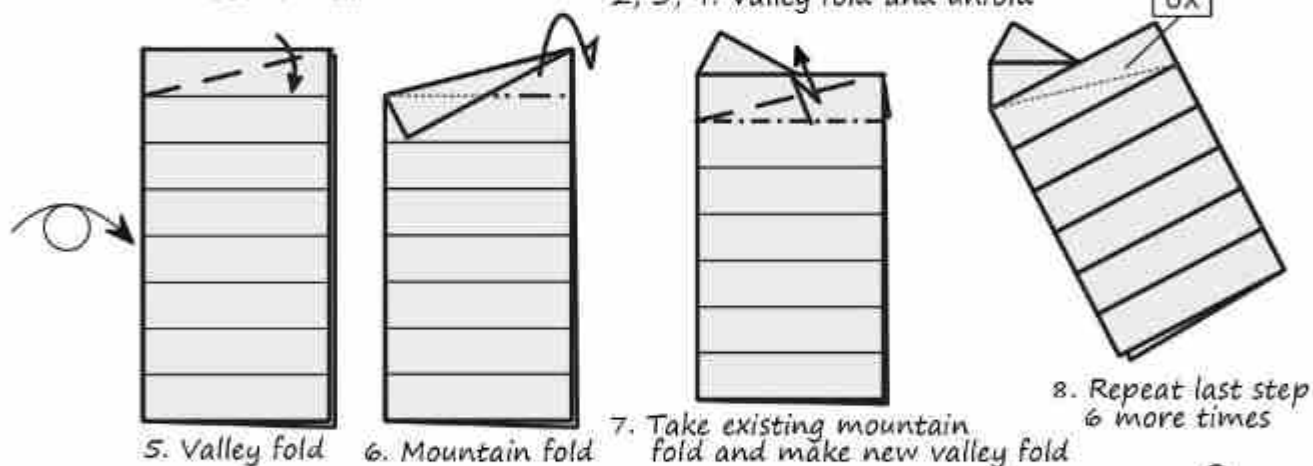
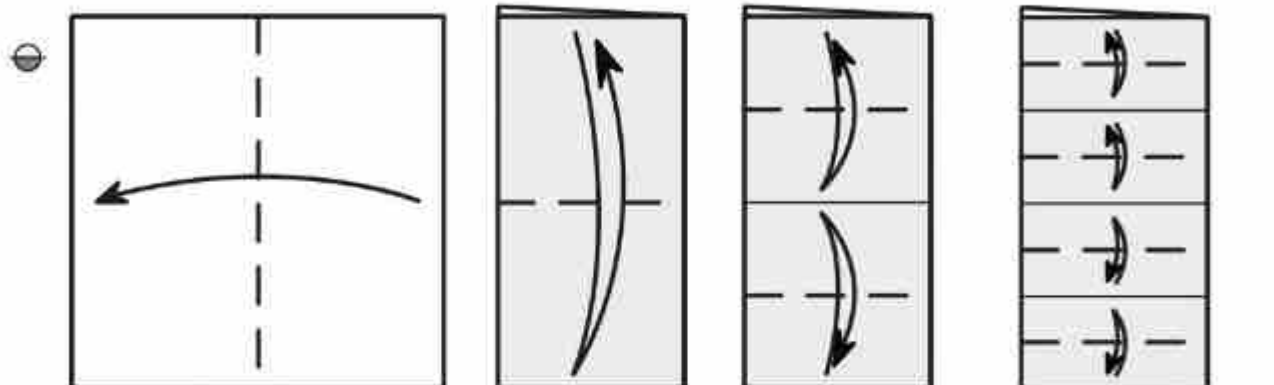

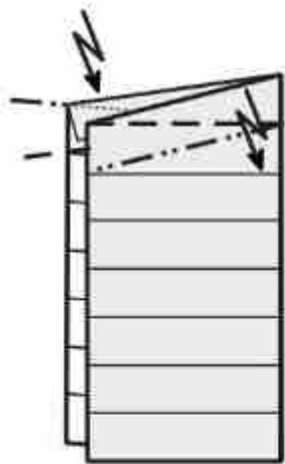

12. Zig-zag fold inside

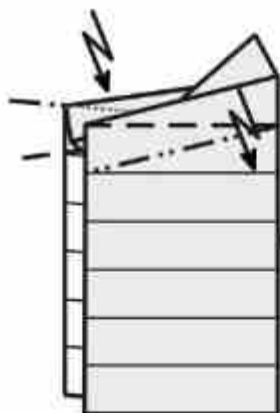

13. Repeat step 12
6 times

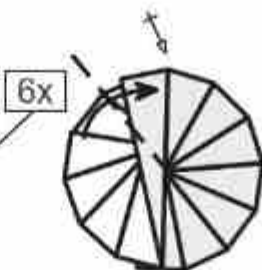

14. Valley fold front
and back to
make wings



3x

15. 3D result
Make 3 of these

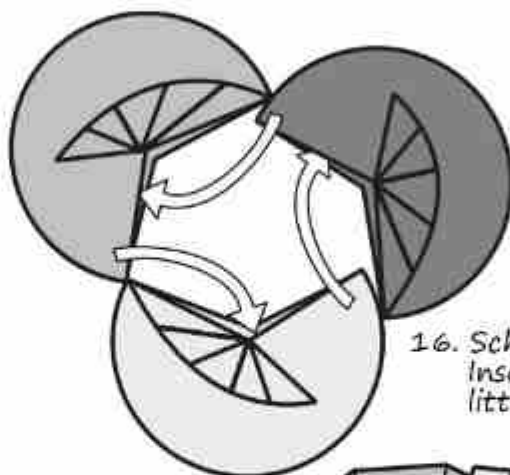
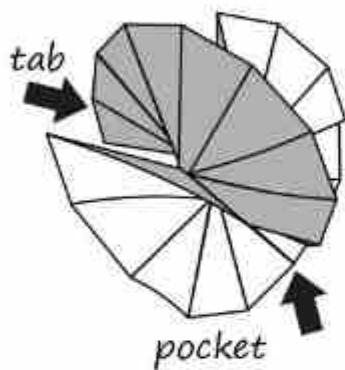

16. Schematic view
Insert the tabs for a
little bit in the pockets



www.orihouse.com
Insta: orihouse1
Flickr: orihouse
FB: Paula Versnick

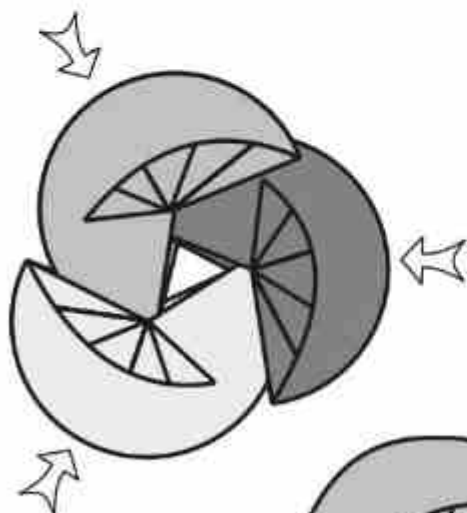

17. Push the tabs in
the pockets and
distribute evenly

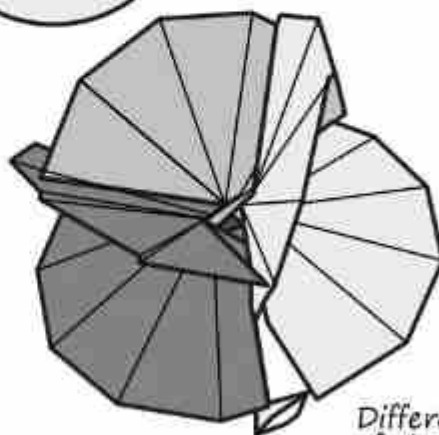

Different views
of the same object

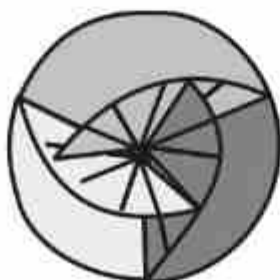

18. Finished!

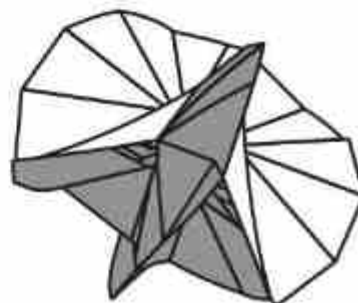

Fairy Night 451

Eric Vigier

©2020 - France

Intermediate

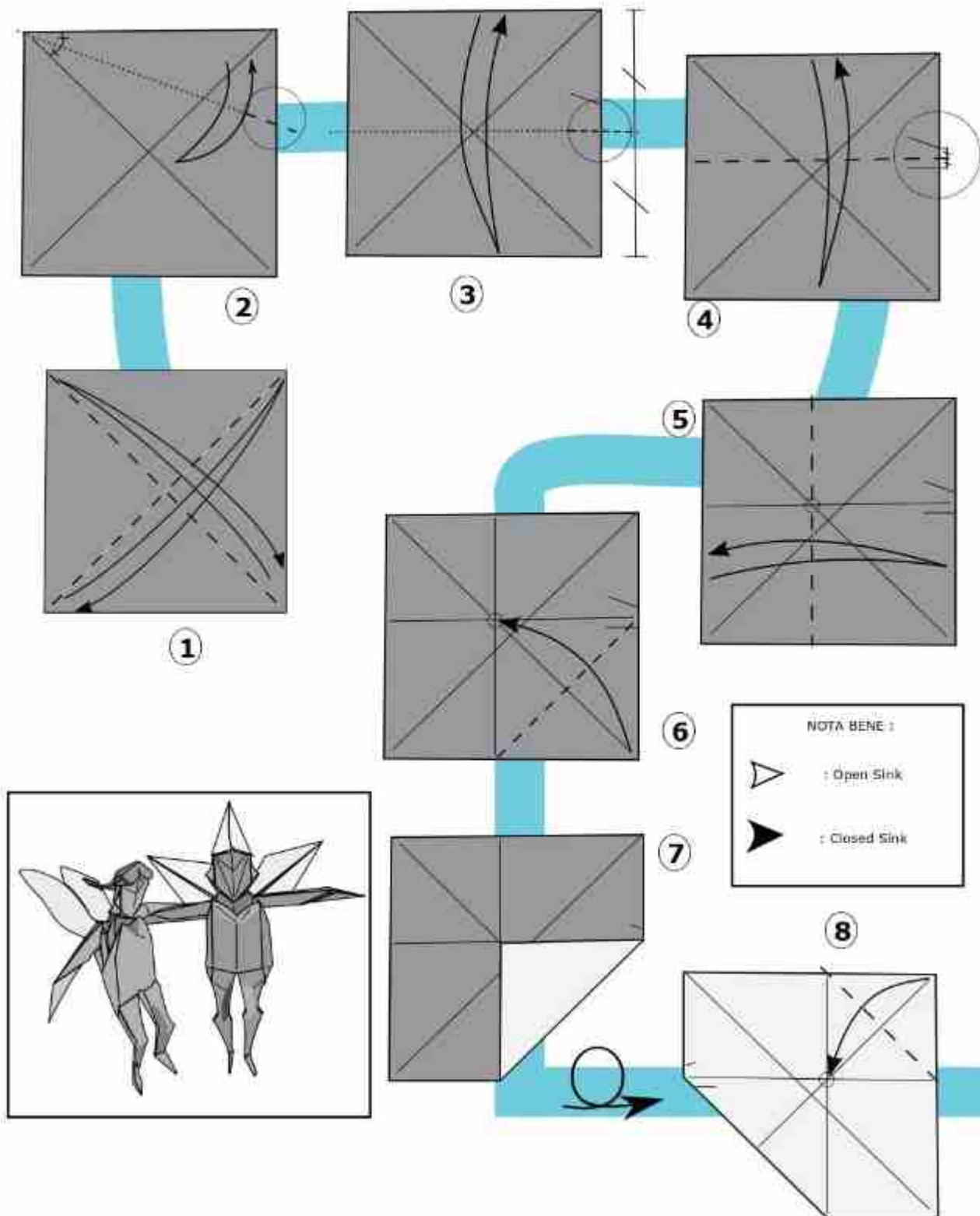

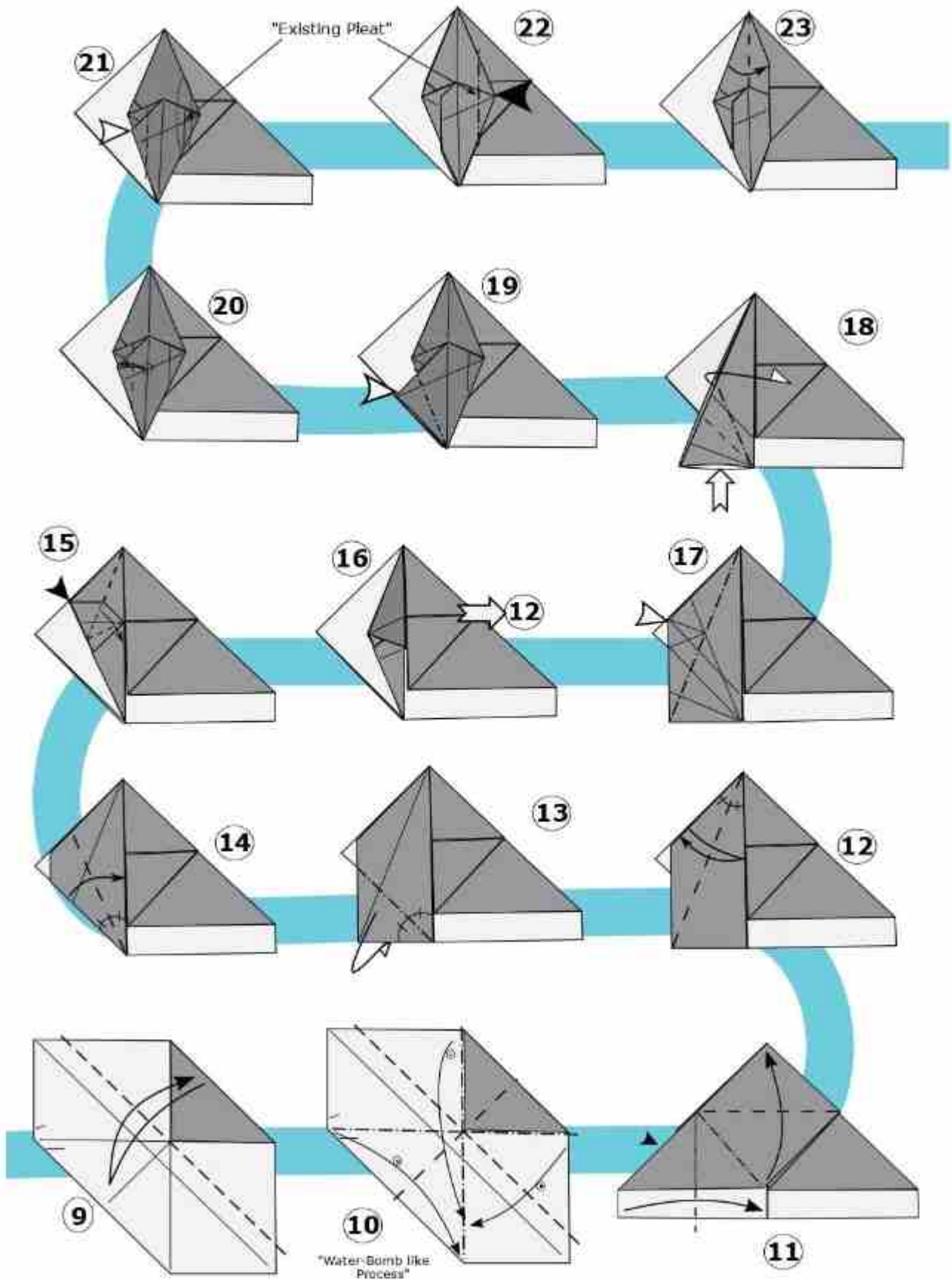

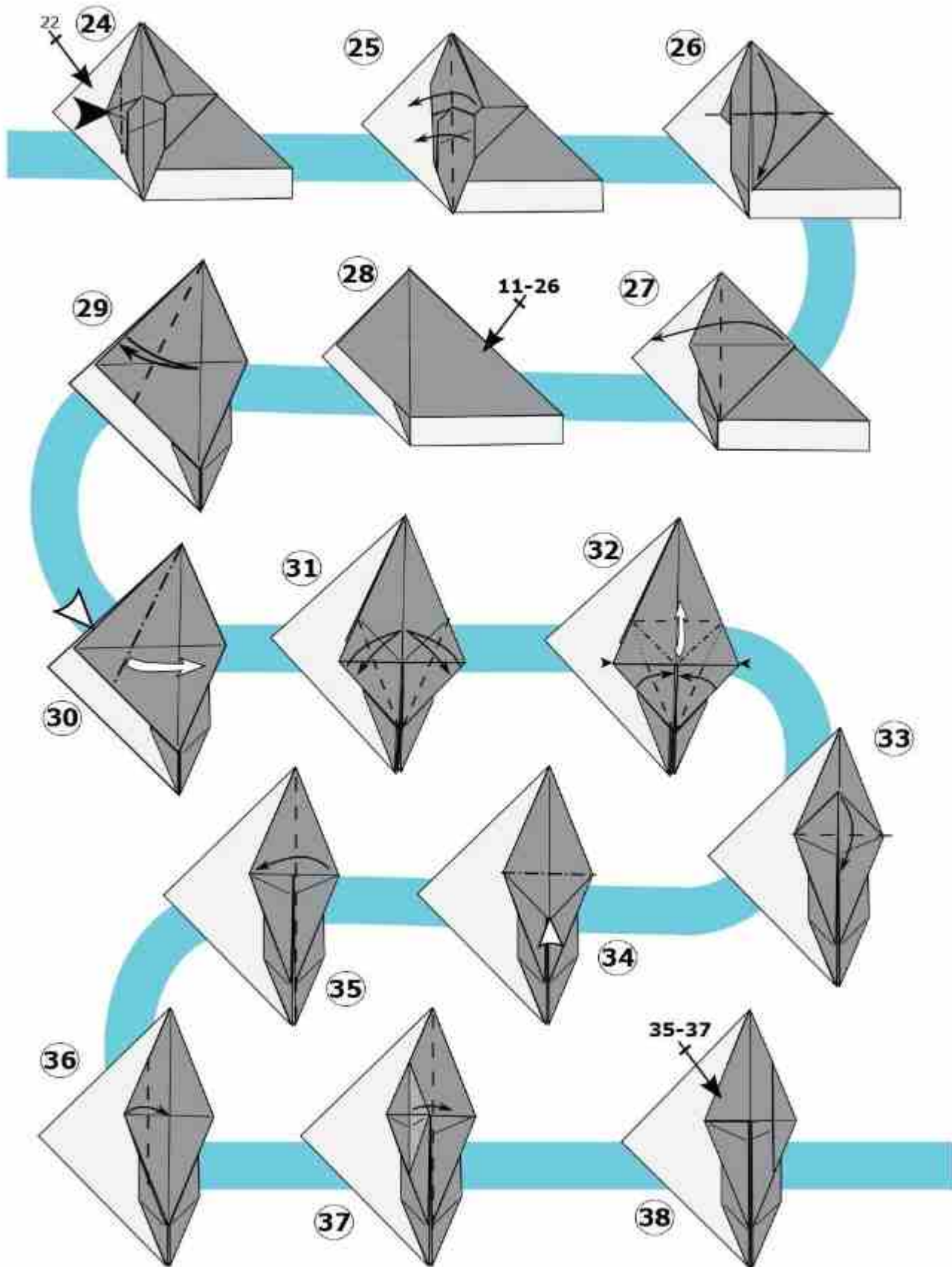

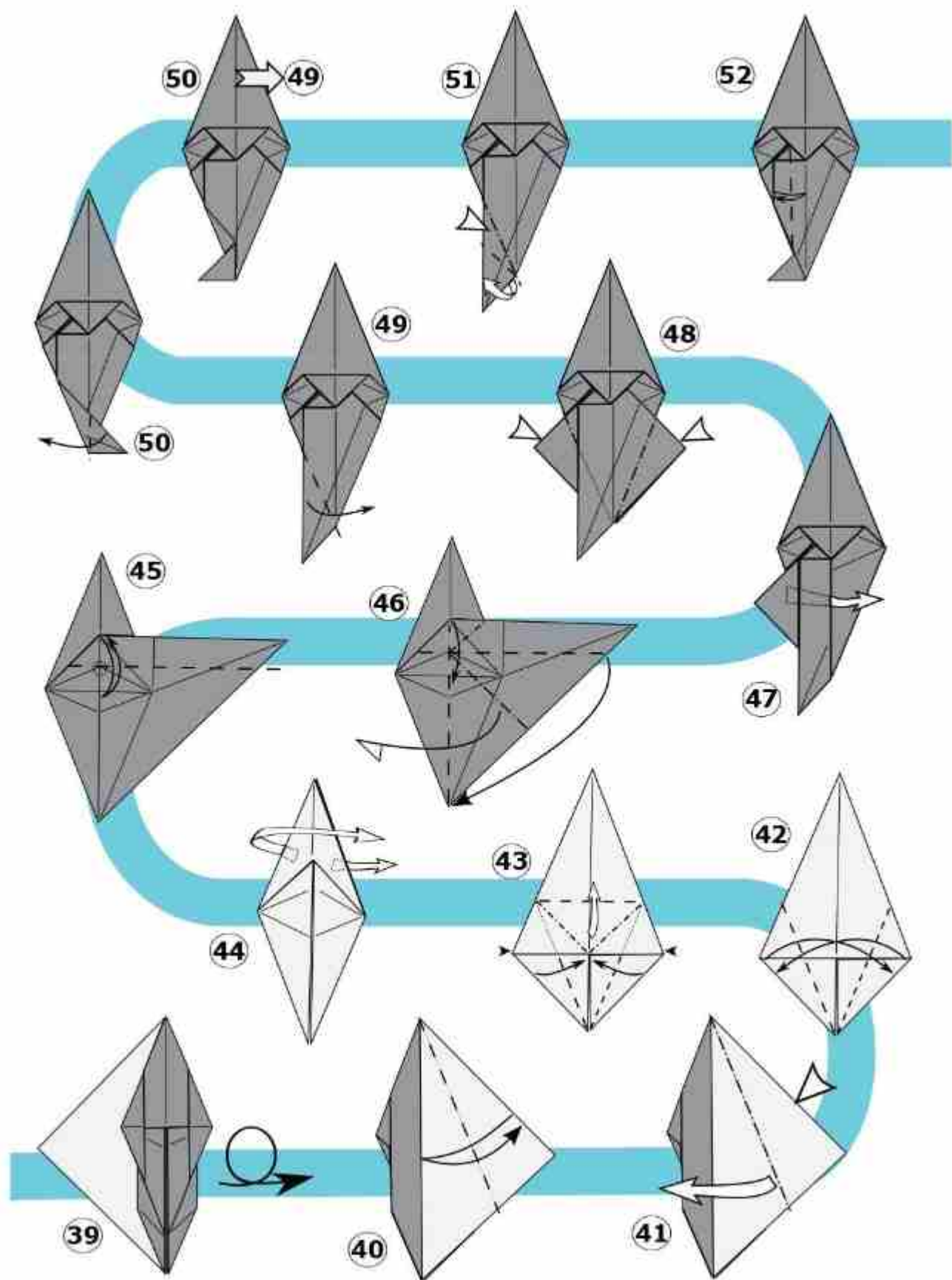

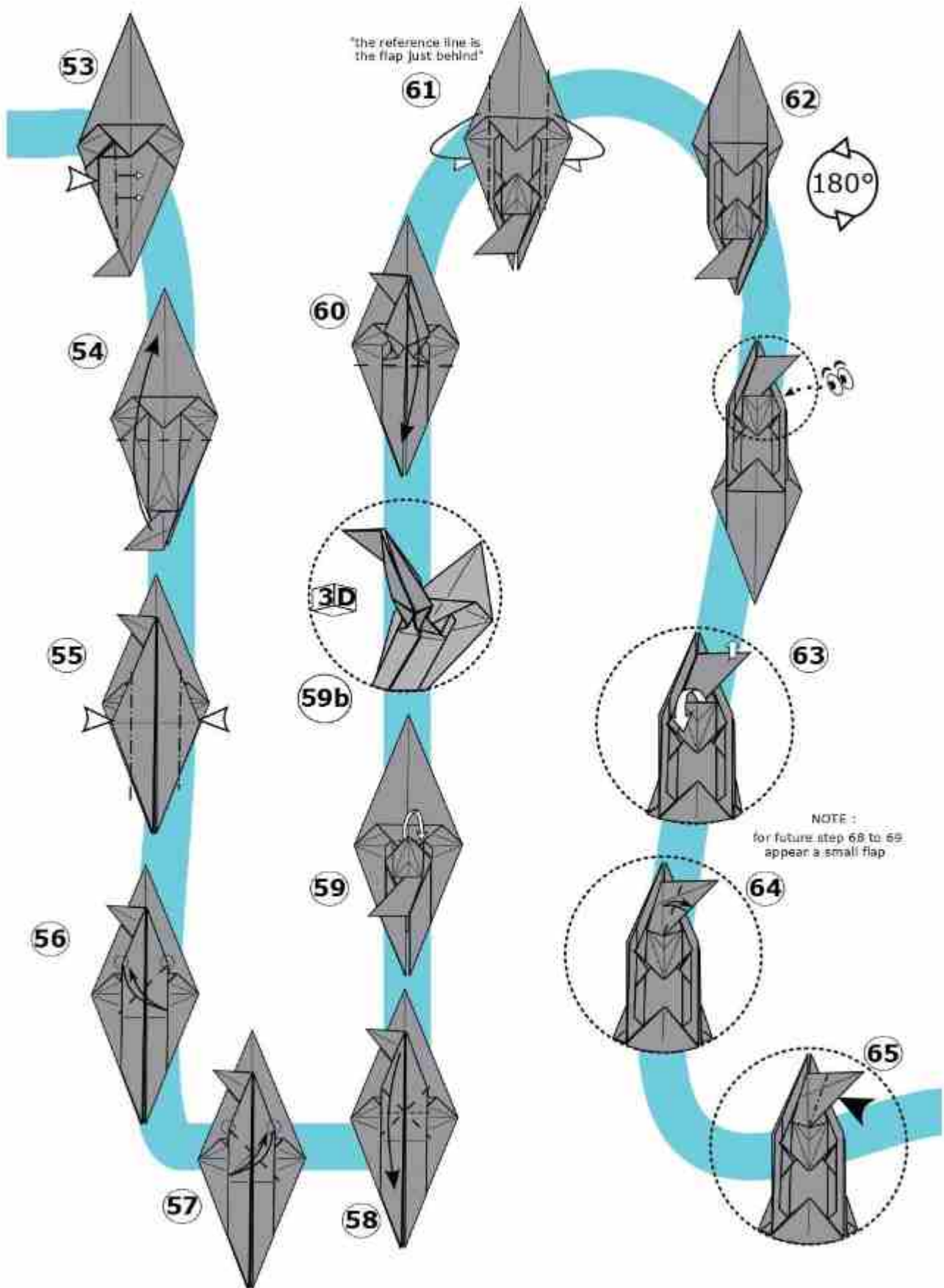

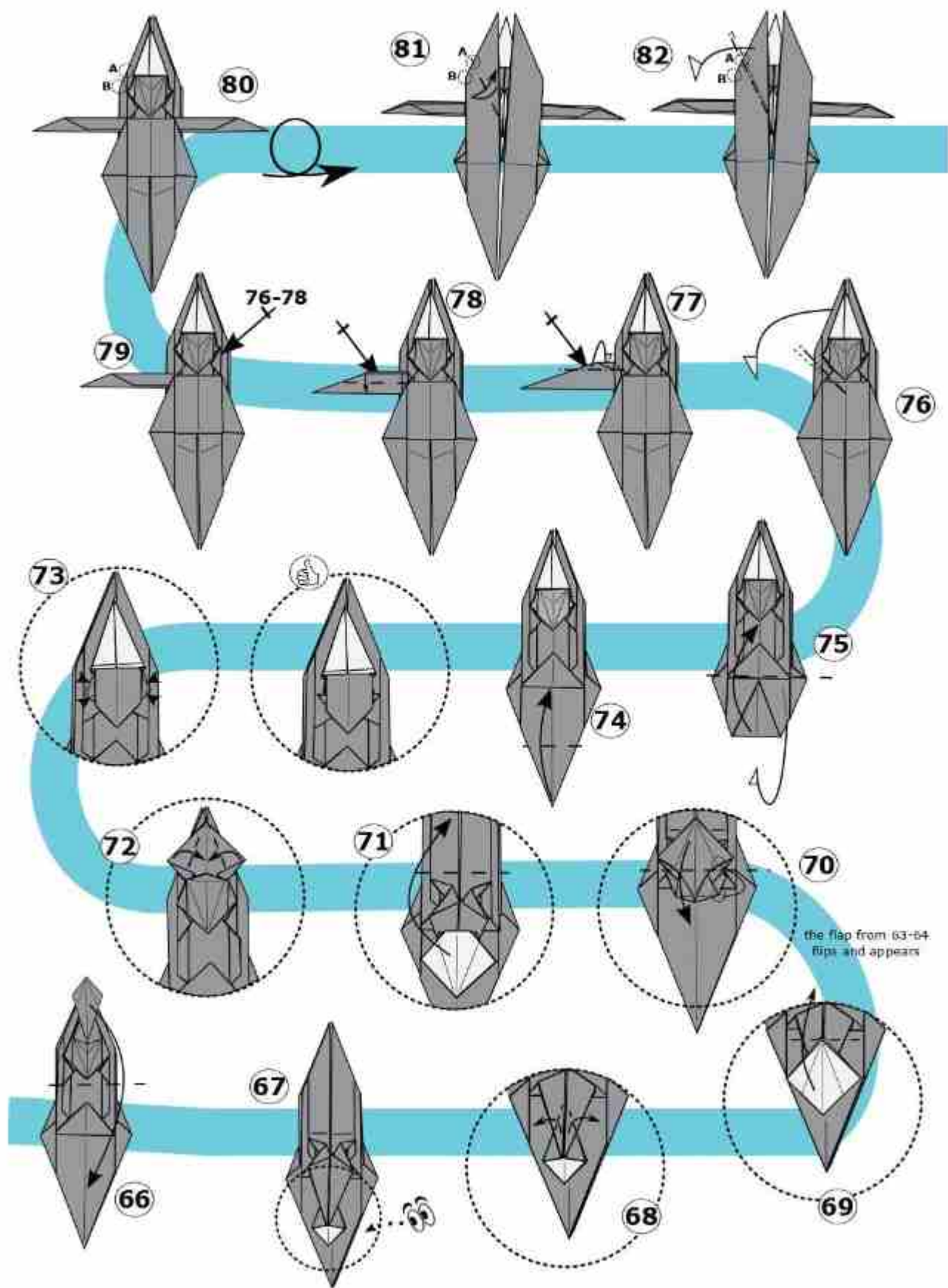

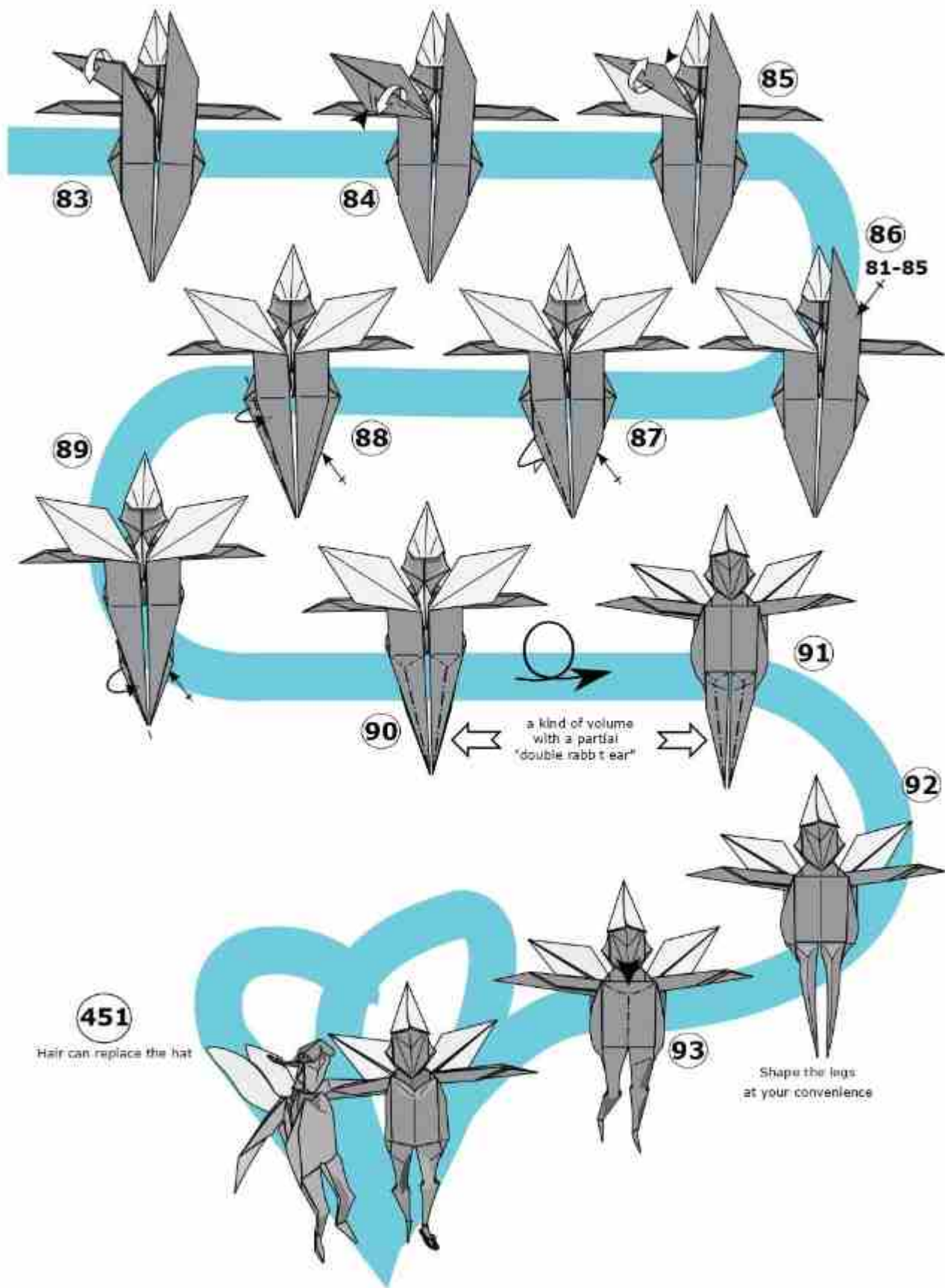

Torii

Eric Vigier
©2019 - France

Intermediate

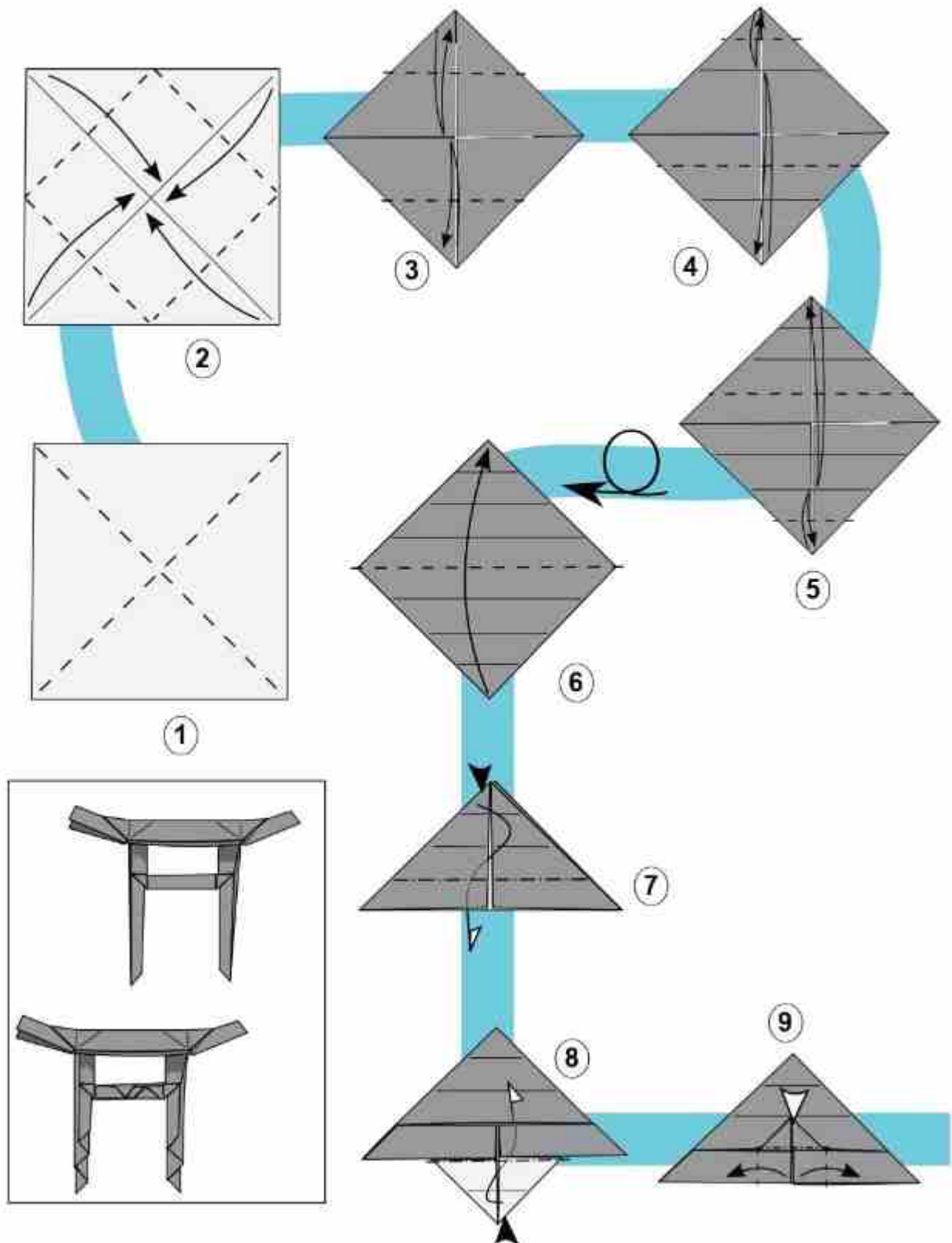

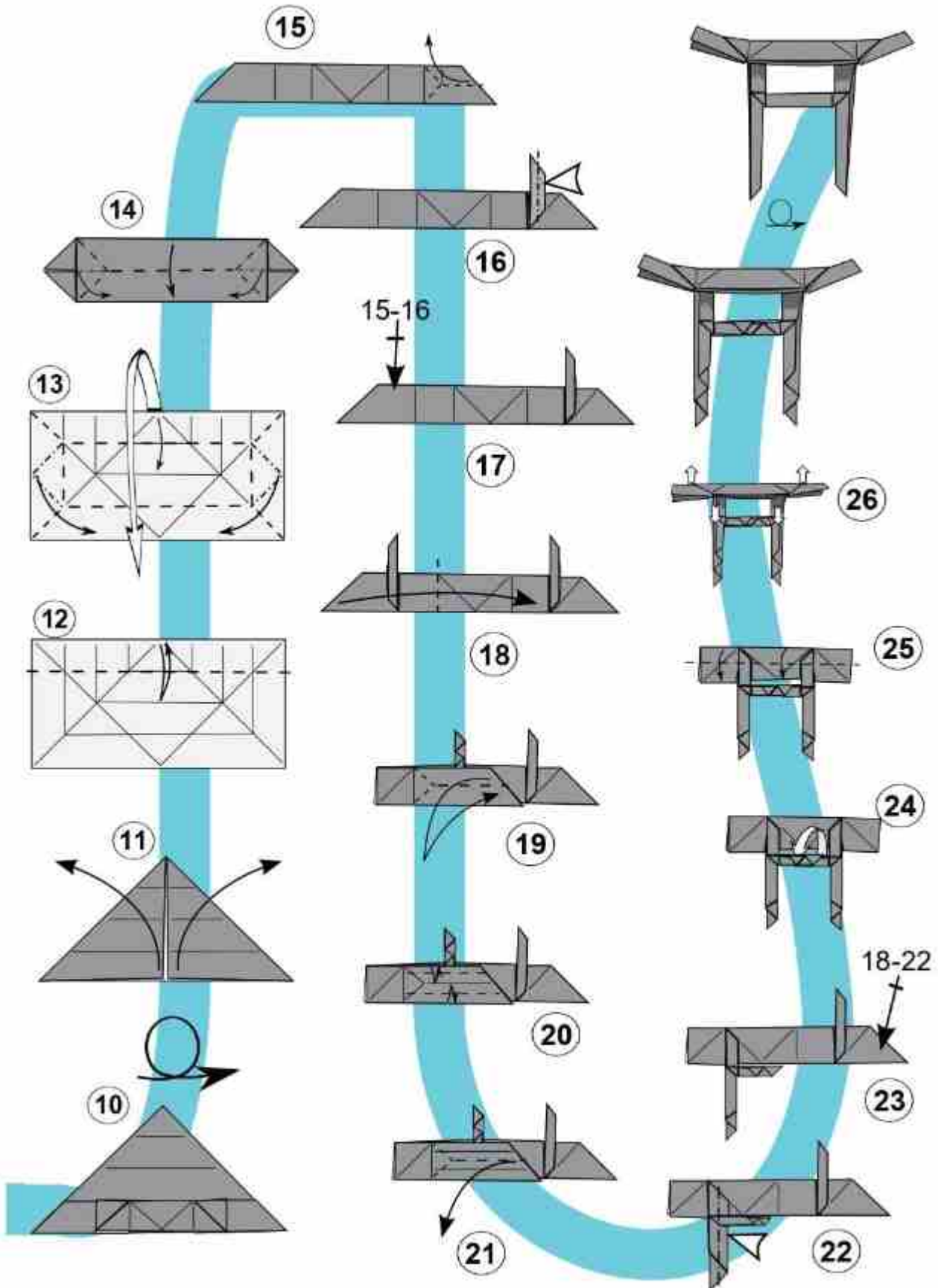

© Eric VIGIER

One Page Cube

L. Fernandez Vilanova

©2023 - Spain

Intermediate

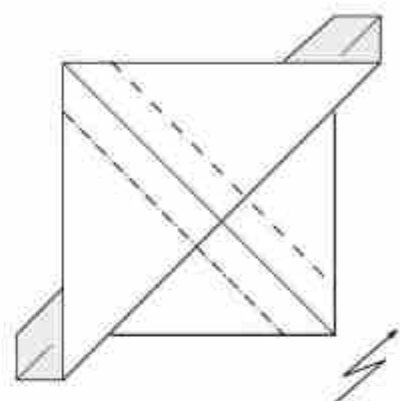
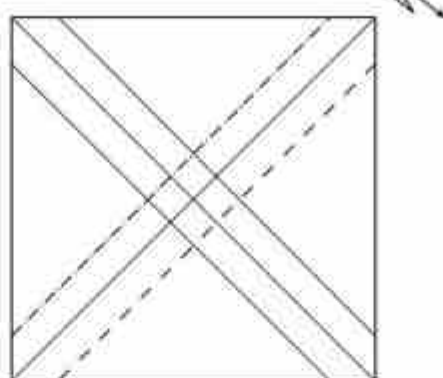
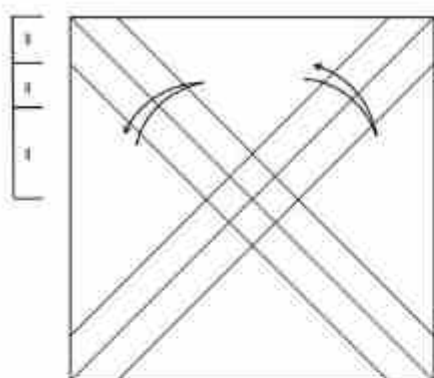

2.

3.

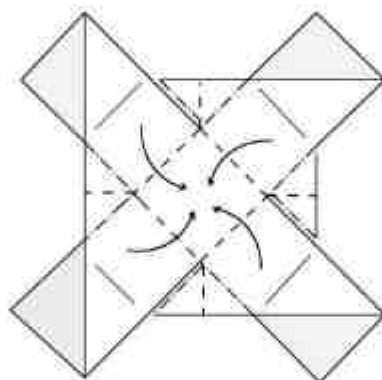
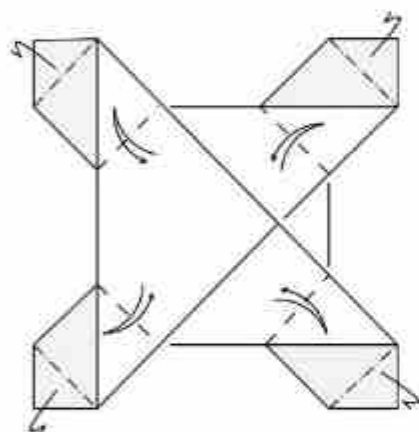

4.

5.

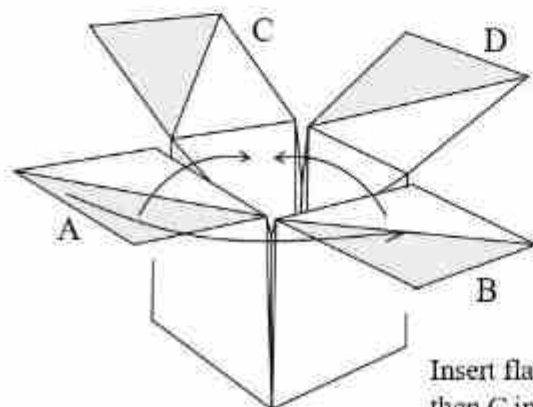

6.

Insert flap A into B's inner pocket
then C into B's outer pocket
then D into C and B's pockets.

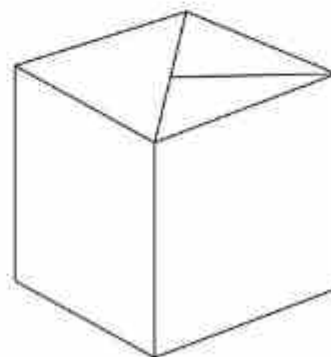

Alpaca

High Intermediate

Javier Vivanco

©2019 - Peru

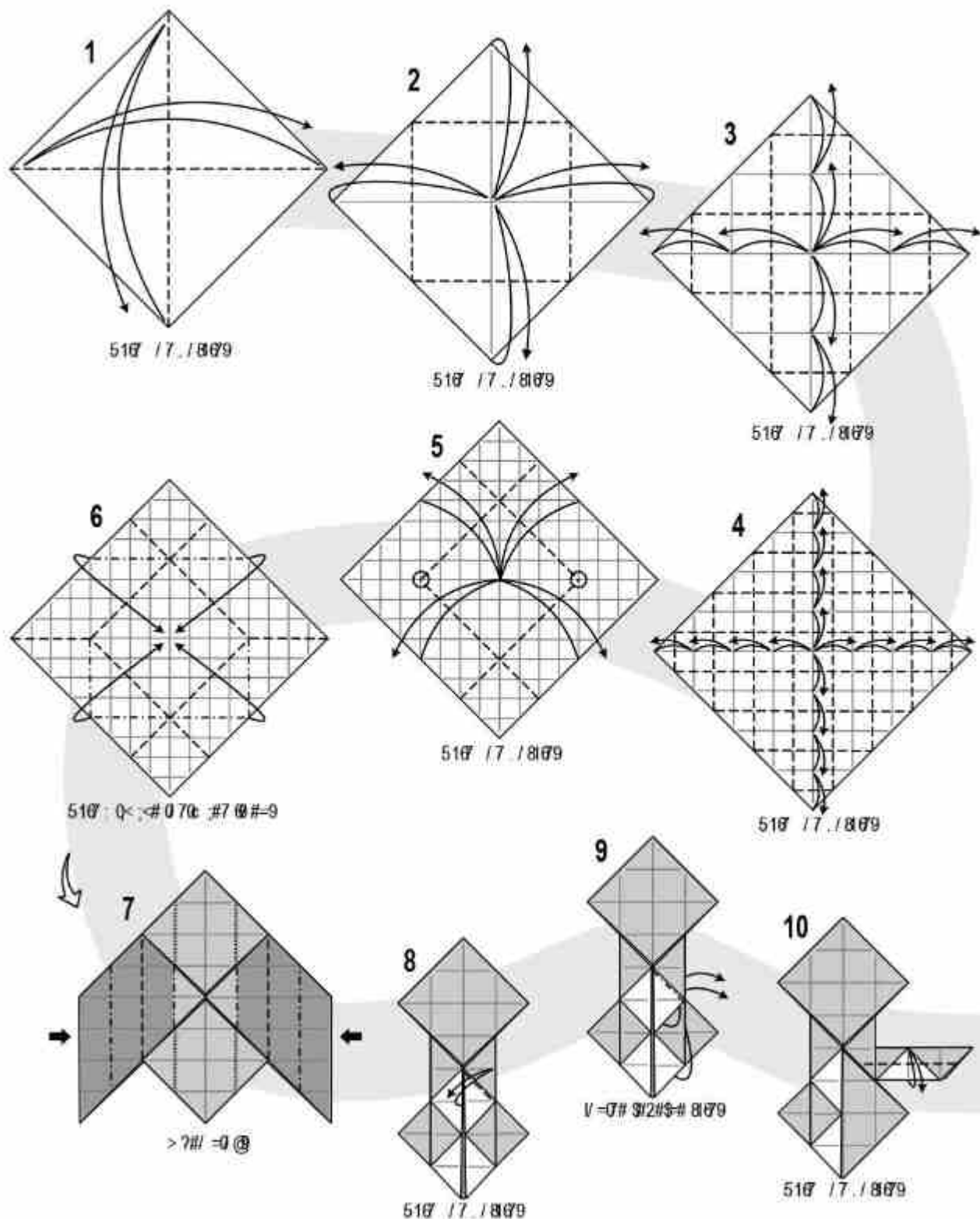

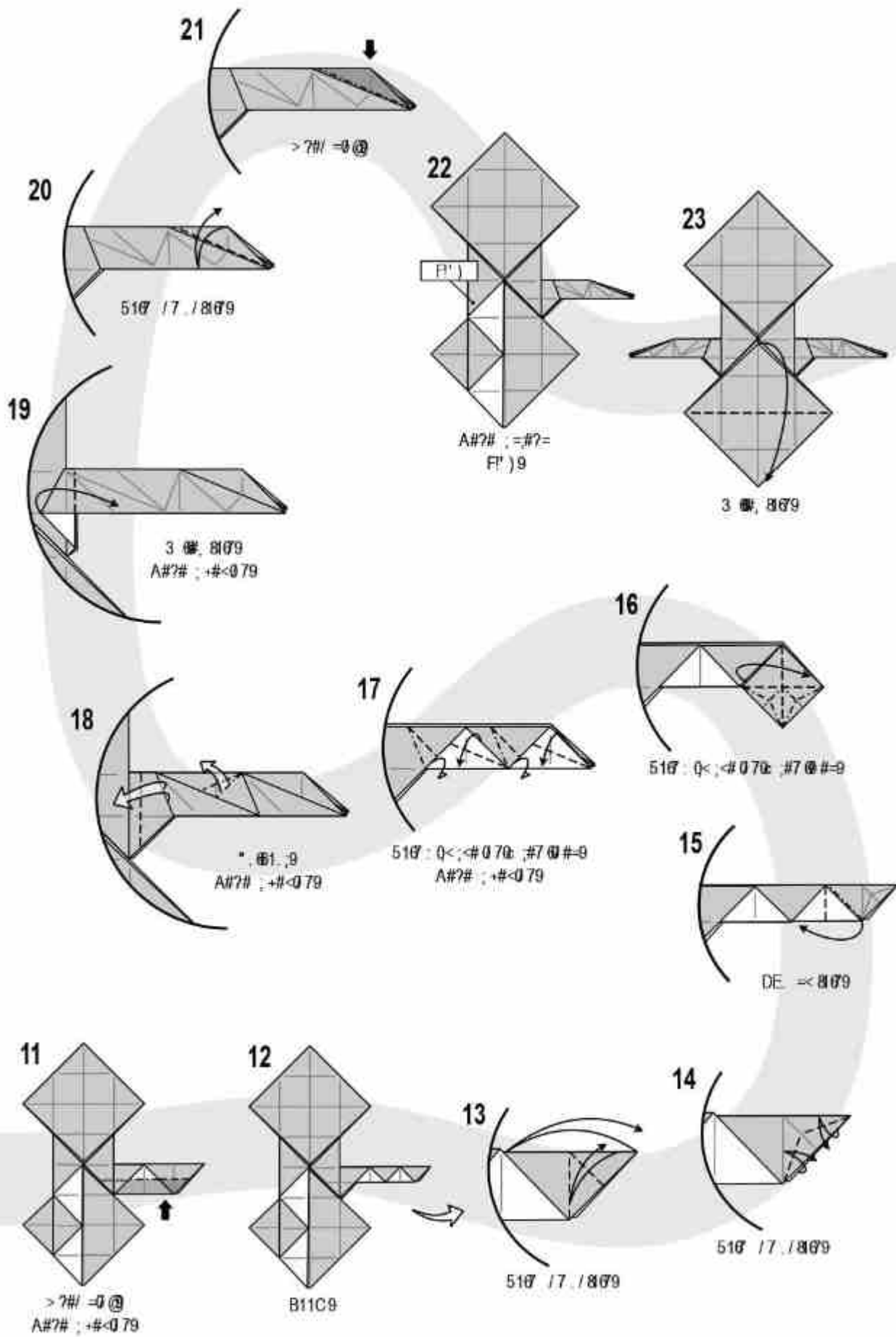

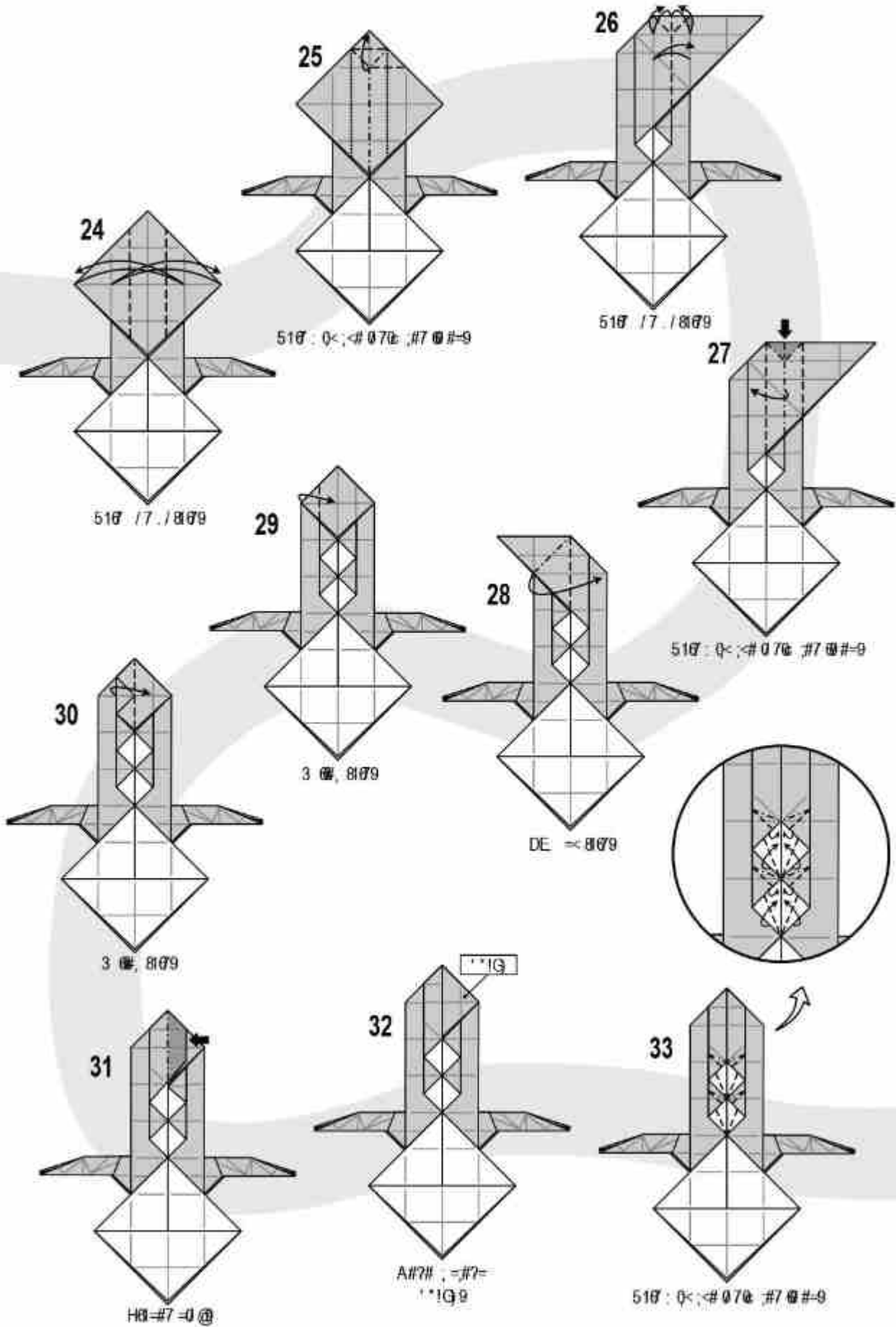

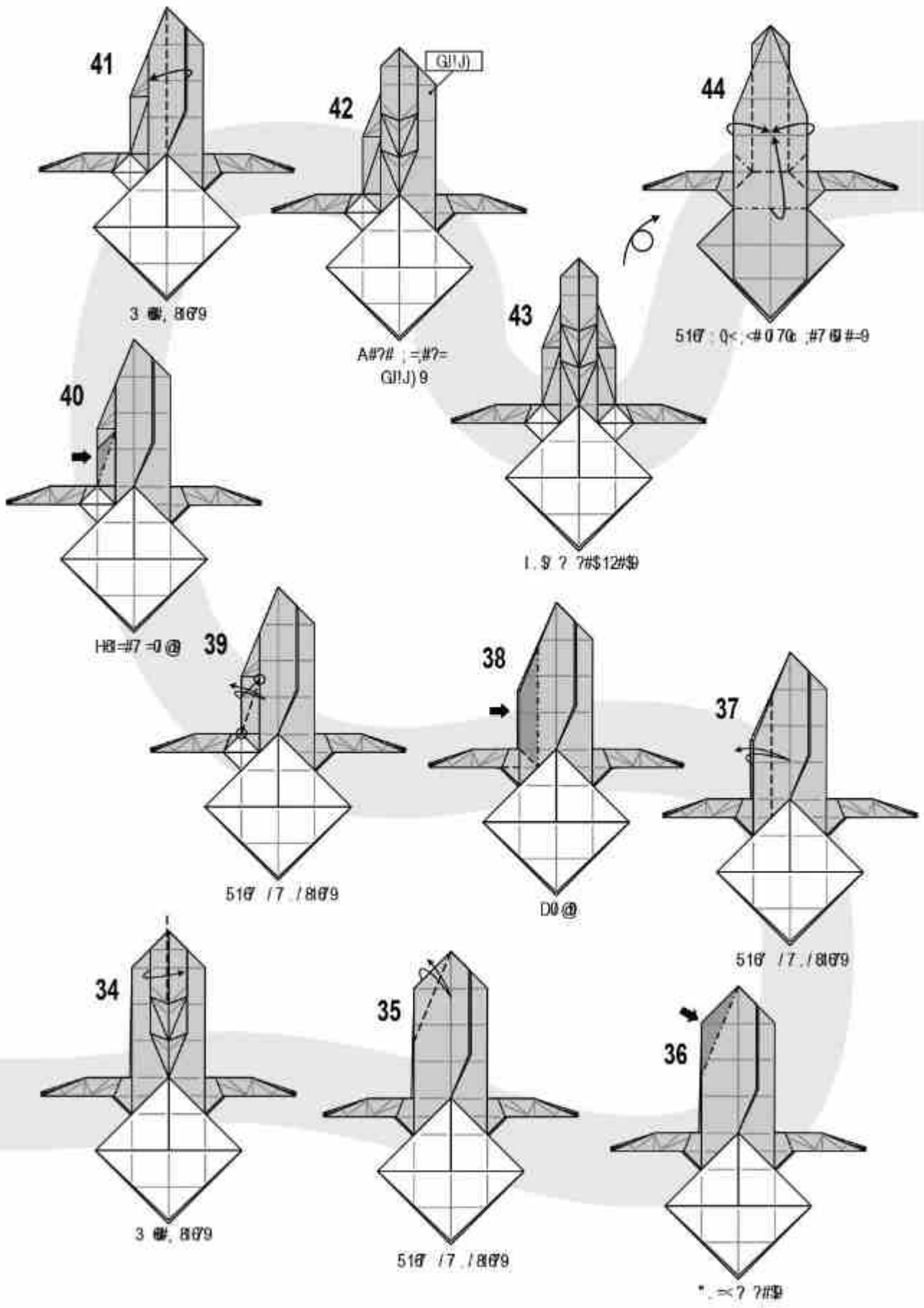

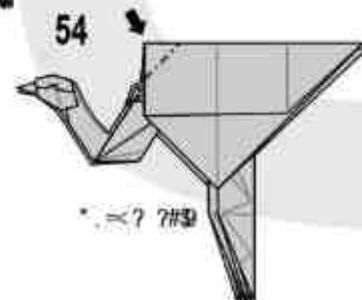
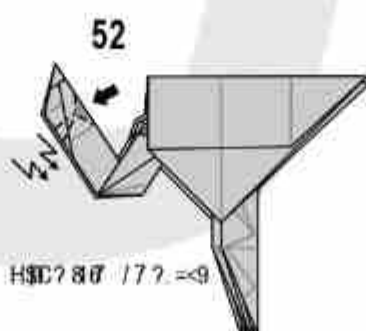
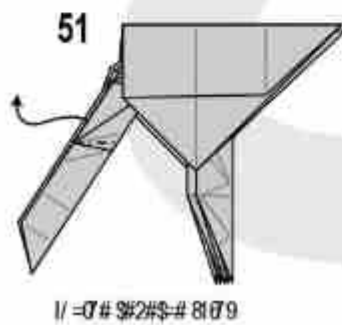
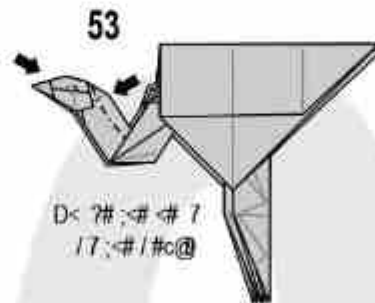
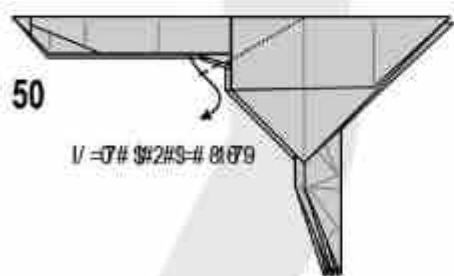
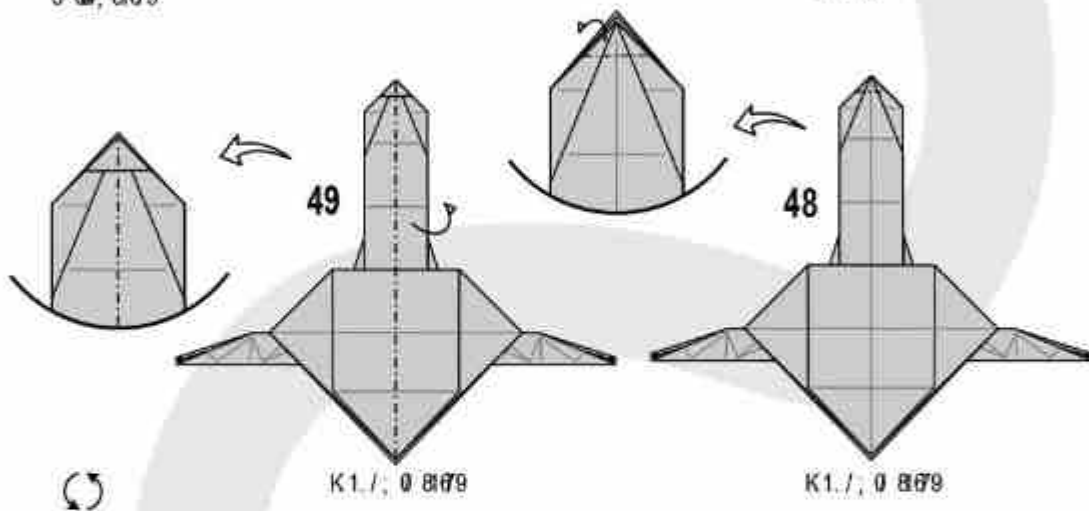
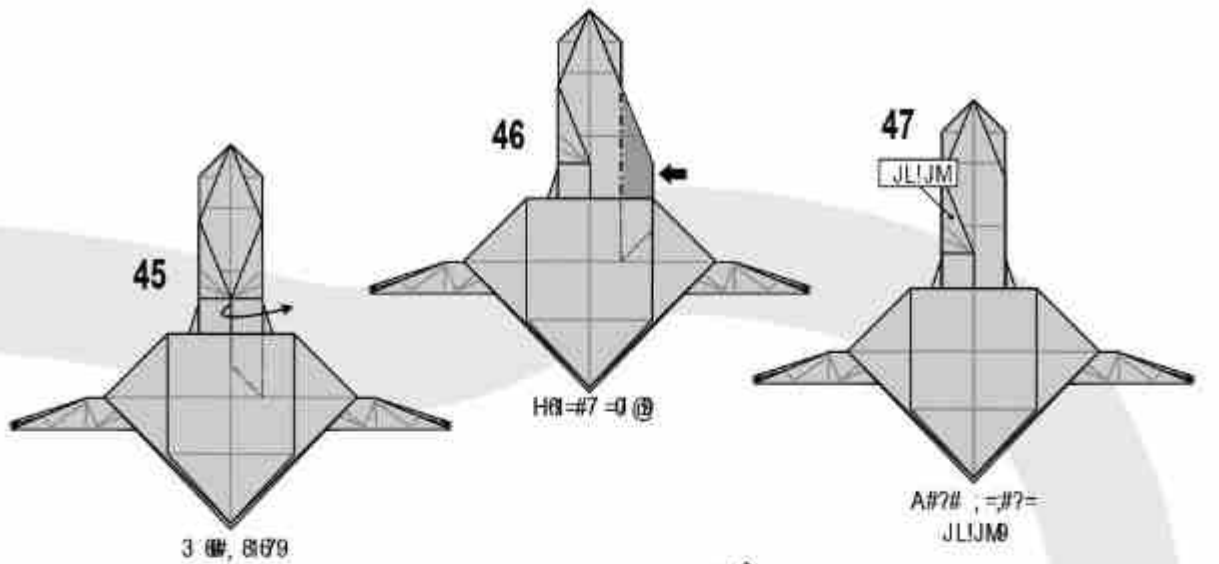

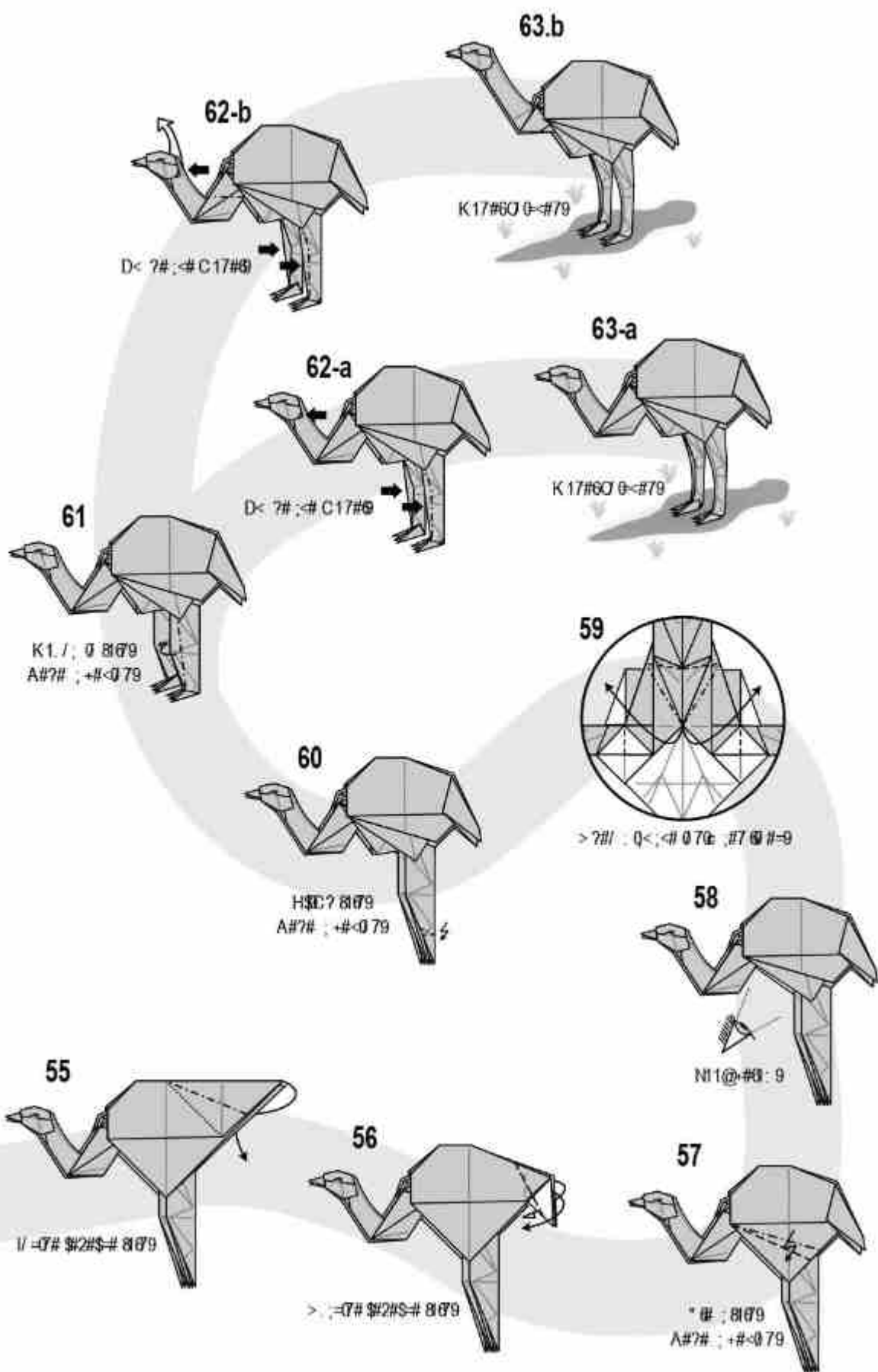

Fox

Intermediate

Caleb Witte

©2022 - USA

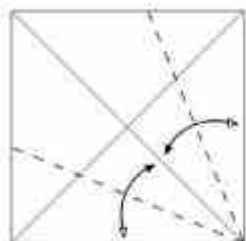

1) Valley fold
Unfold

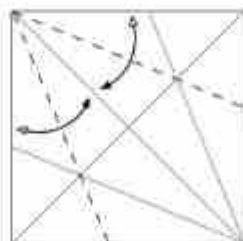

2) Valley fold
Unfold

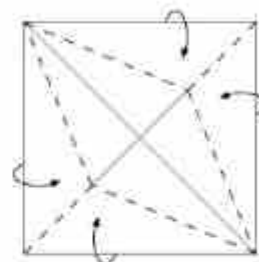

3) Rabbit ear fold

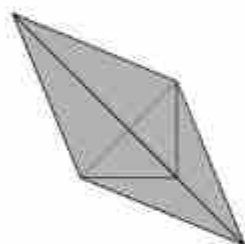

4) Rotate

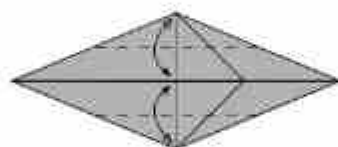

5) Valley fold
Unfold

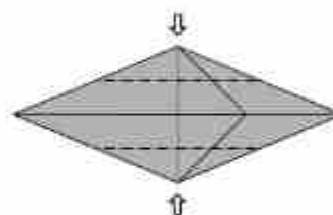

6) Open sink



7) Result

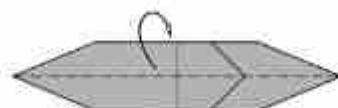

8) Mountain fold



9) Result



10) Inside reverse

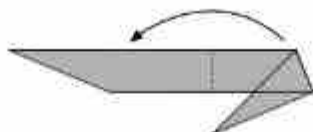

11) Valley fold



12) Valley fold

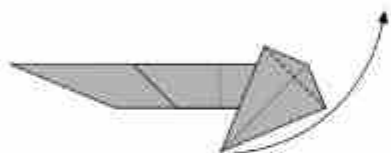

13) Valley fold



14) Mountain fold



15) Crimp fold



18) Outside reverse



17) Valley fold
Rotate

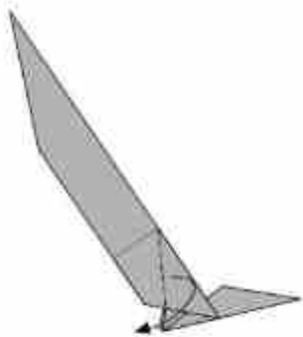

18) Mountain fold

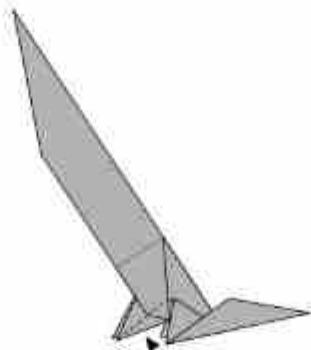

19) Inside reverse



20) Mountain fold

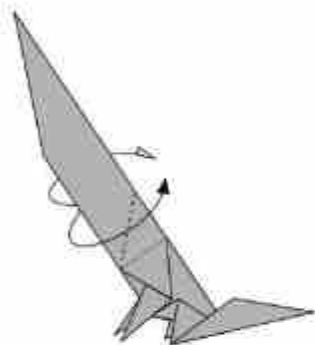

21) Outside reverse

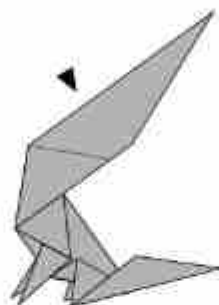

22) Inside reverse

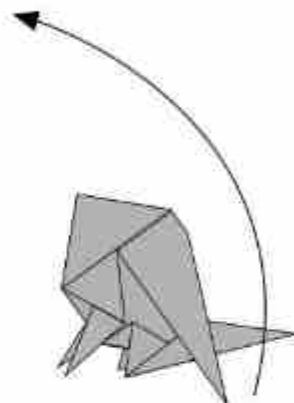

23) Inside reverse

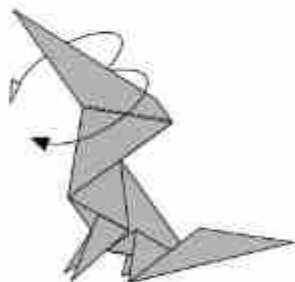

24) Outside reverse

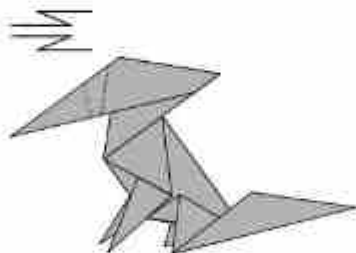

25) Crimp fold



26) Valley fold the nose twice

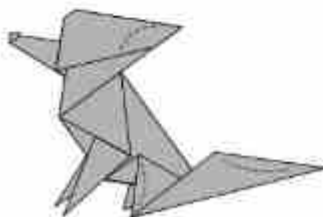

27) Curve the ears, legs, and tail



Finished!

Trendline

Xiao Yao

©2022 - China

Intermediate

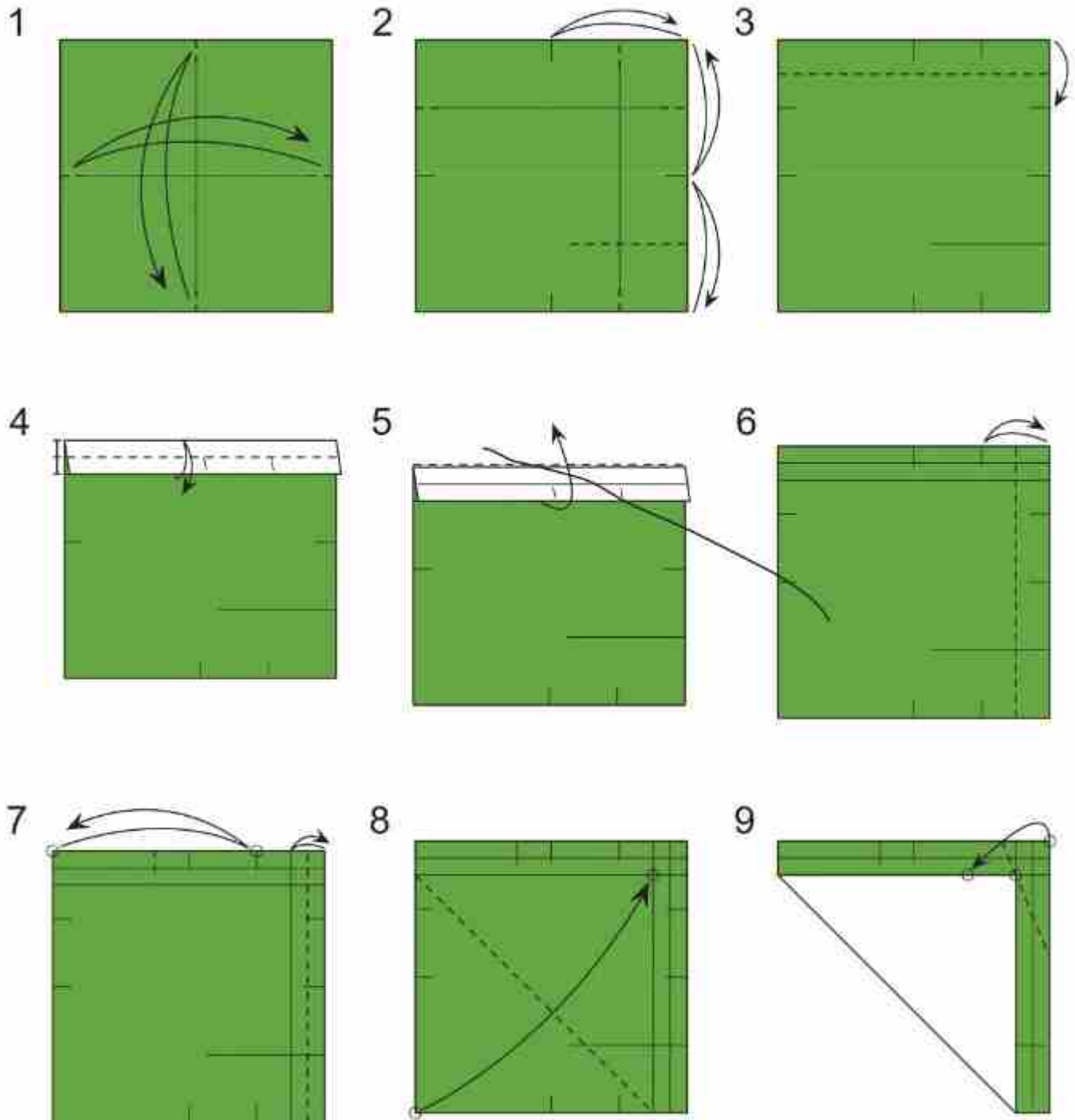

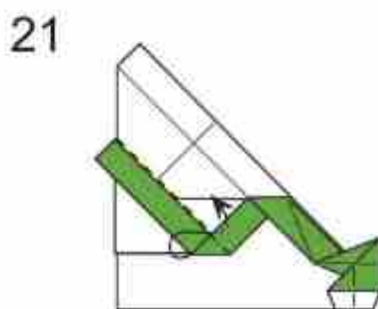
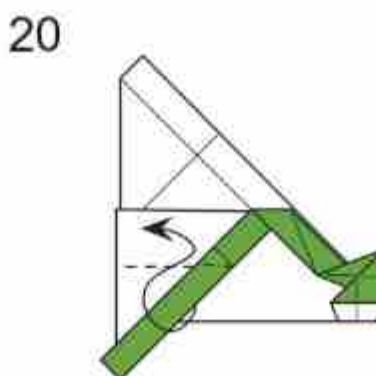
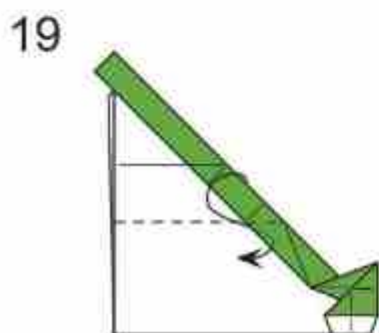
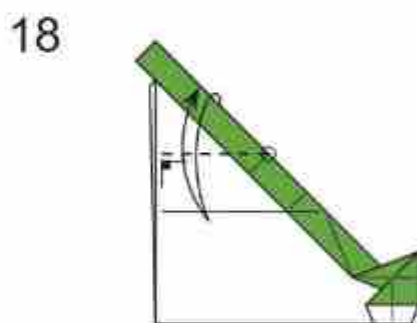
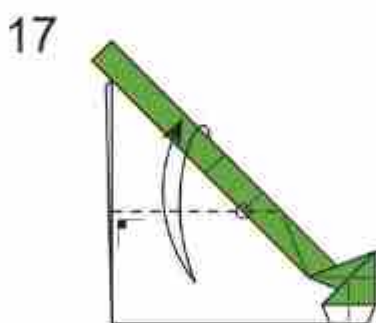
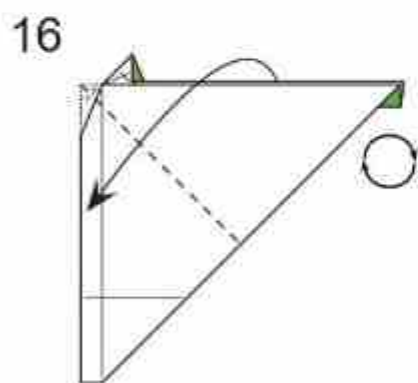
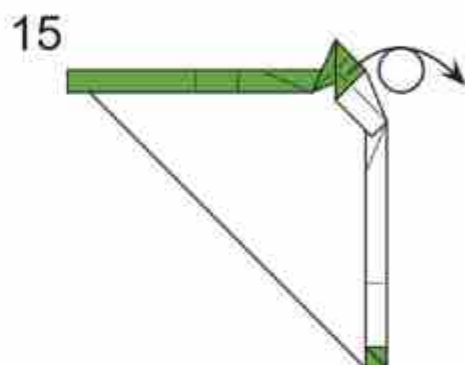
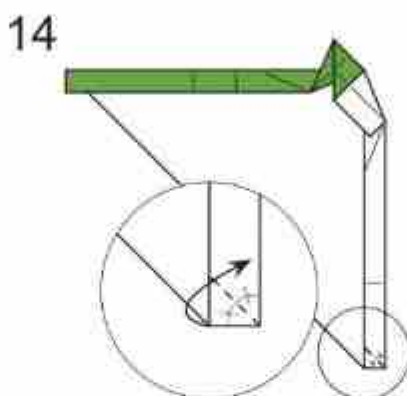
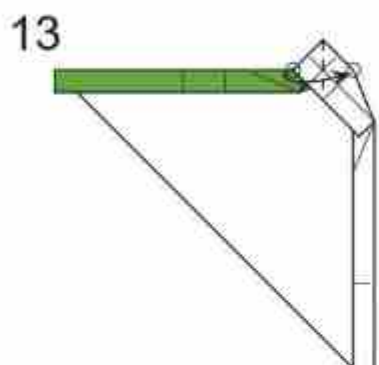
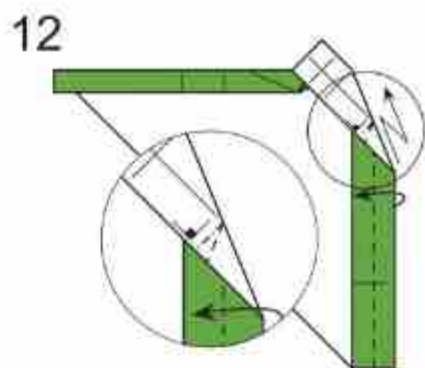
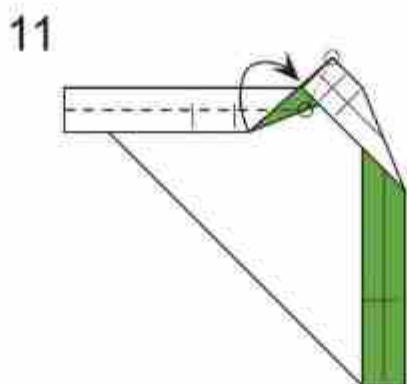
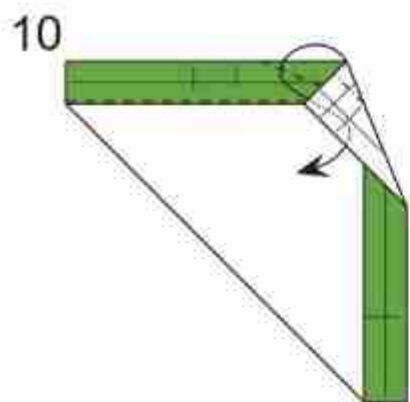

22

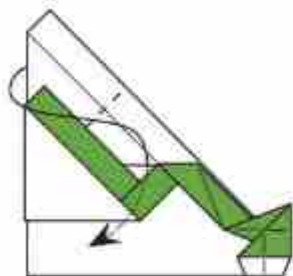

23

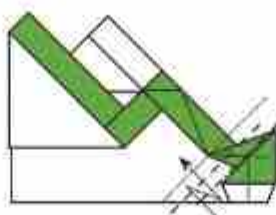

24

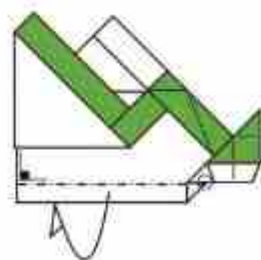

25

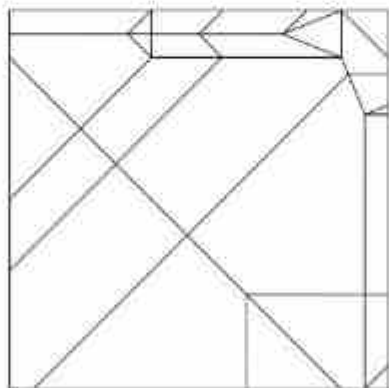
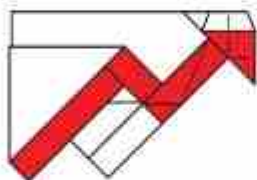
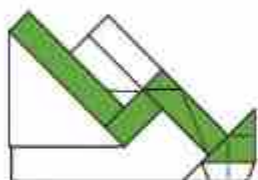

Pythagorean Theorem

Jung Youngshin

©2022 - Republic of Korea

Complex

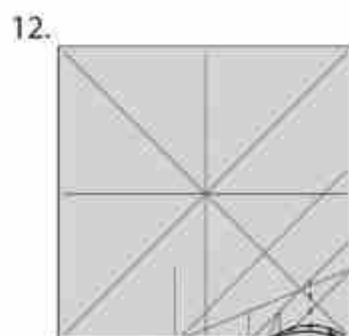
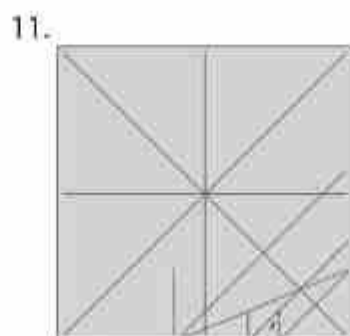
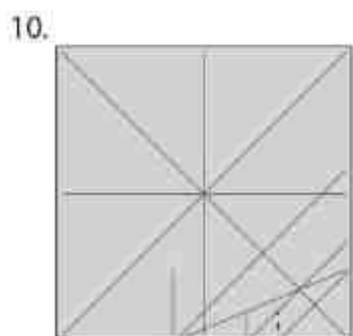
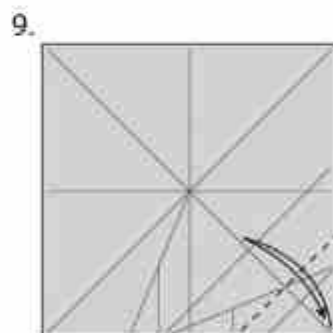
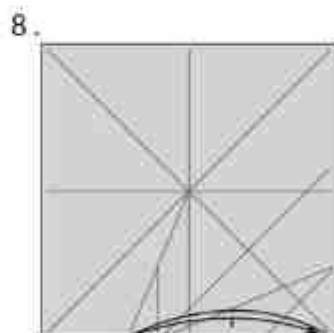
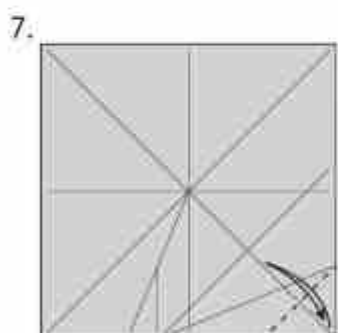
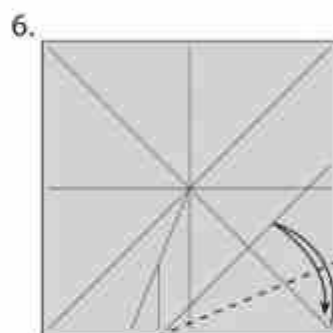
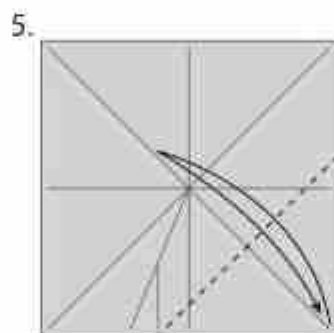
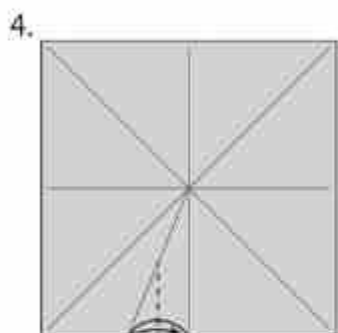
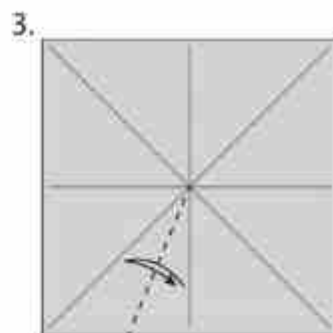
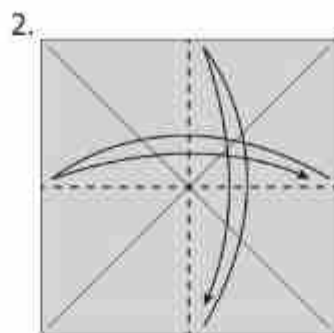
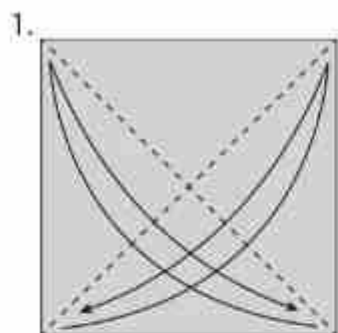

13.



14.

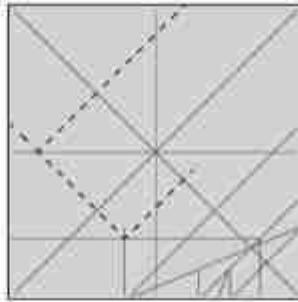

15.

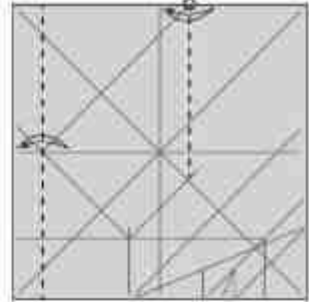

16.

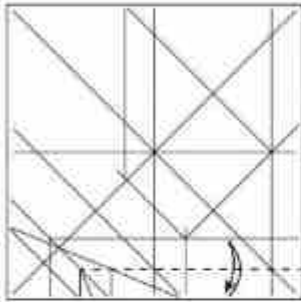

17.

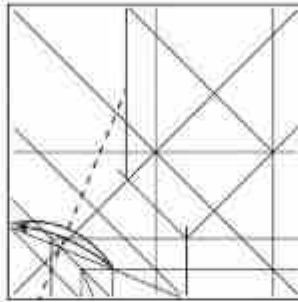

18.

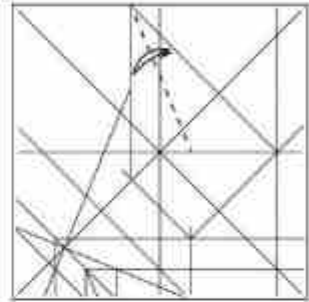

19.

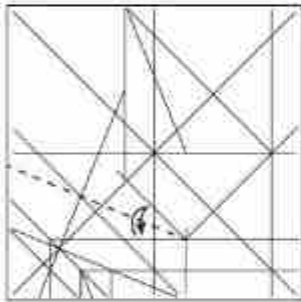

20.

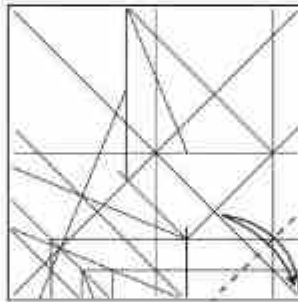

21.

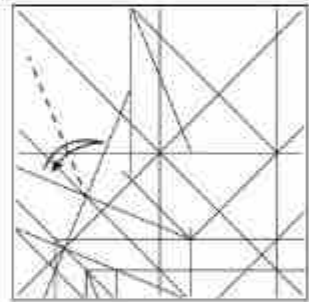

22.

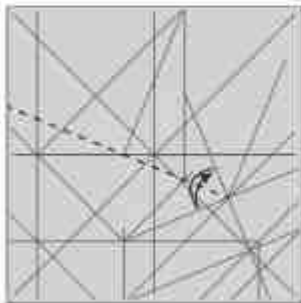

23.

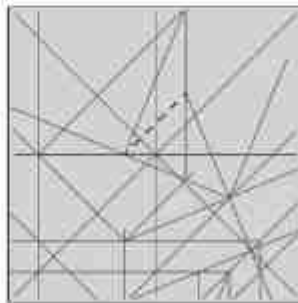

24.

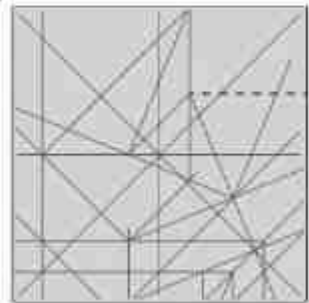

25.

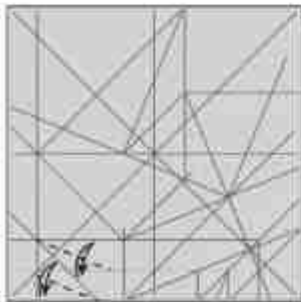

26.

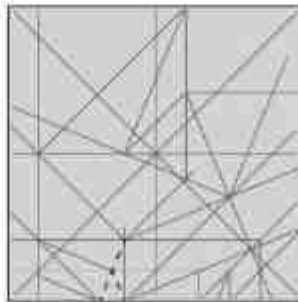

27.

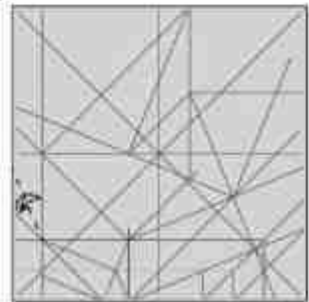

28.

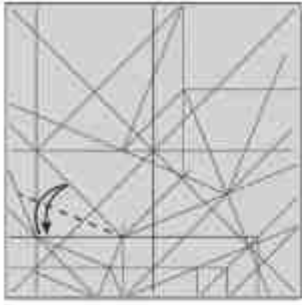

29.

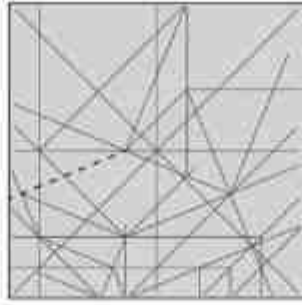

30.

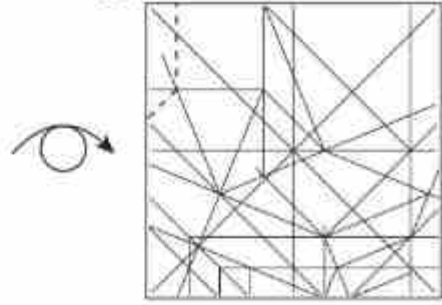

31.

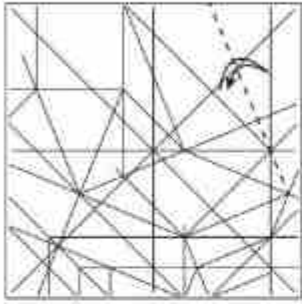

32.

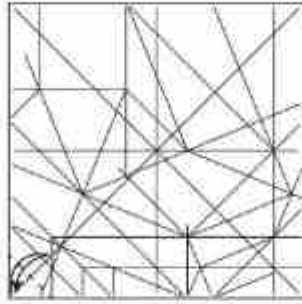

33.

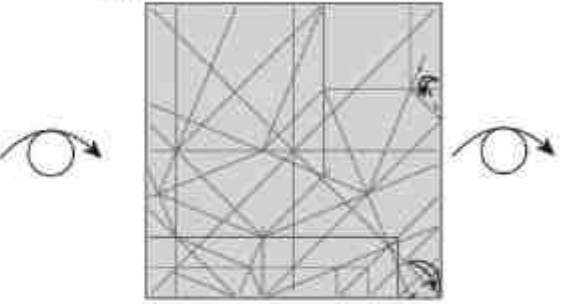

34.

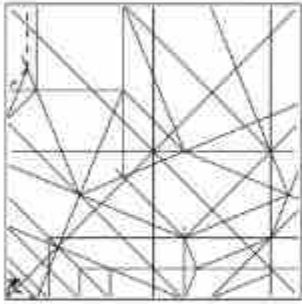

35.

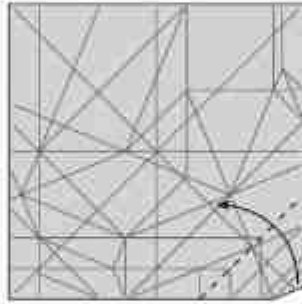

36.

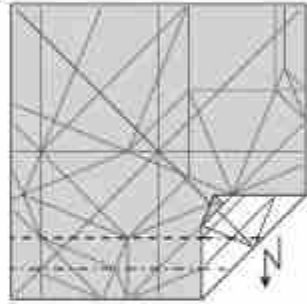

37.

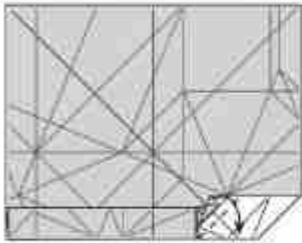

38.

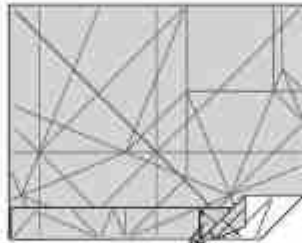

39.

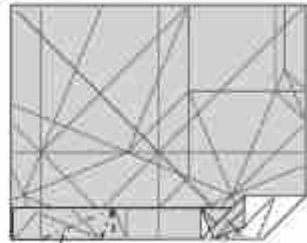

40.

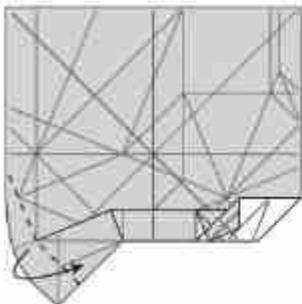

41.

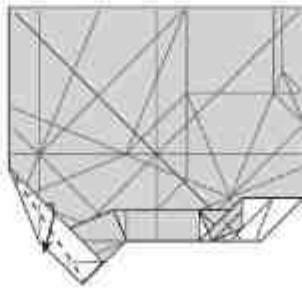

42.

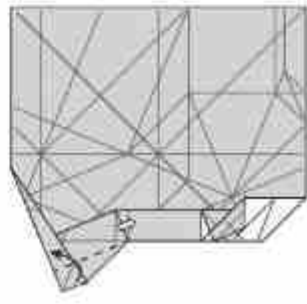

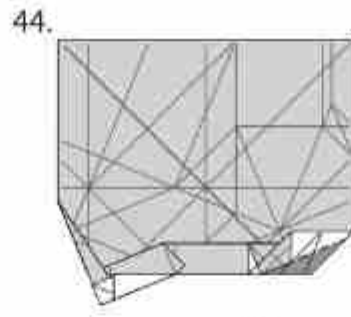
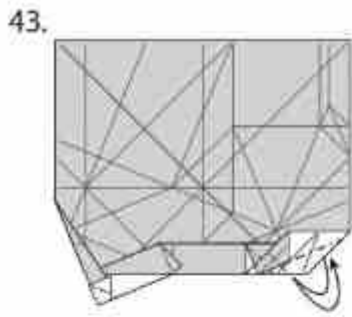

open sink

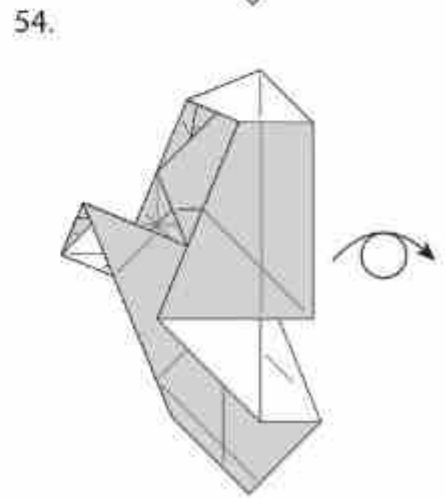
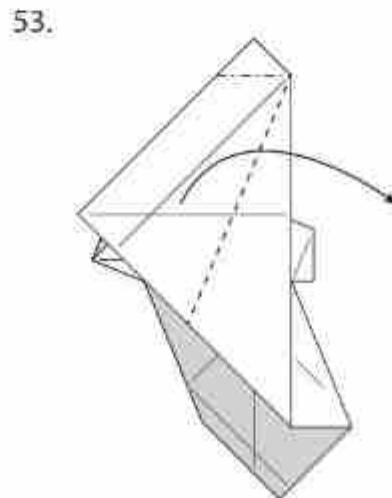
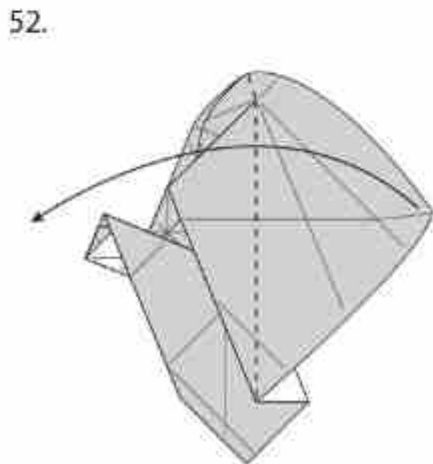
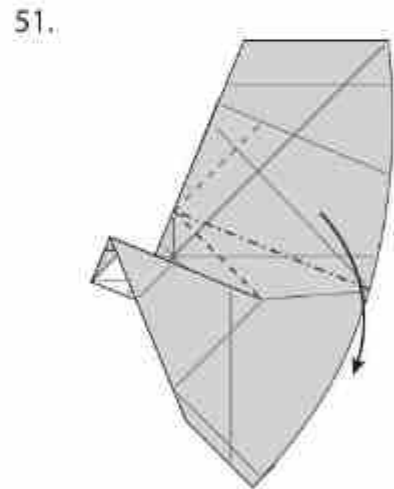
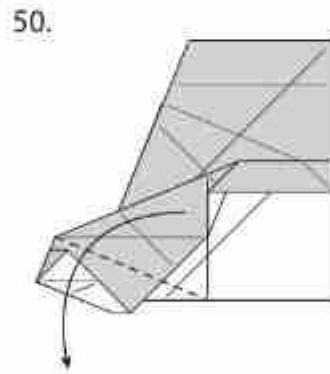
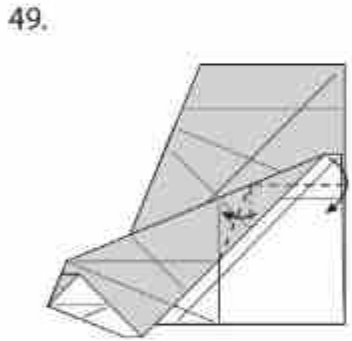
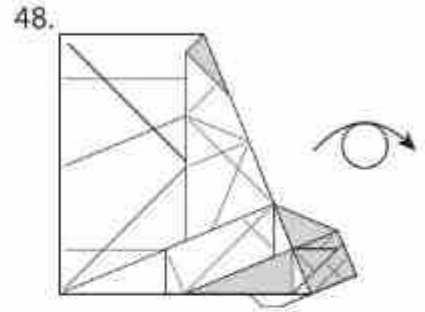
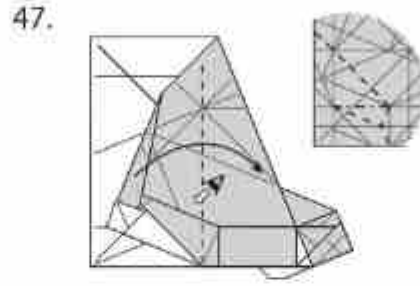
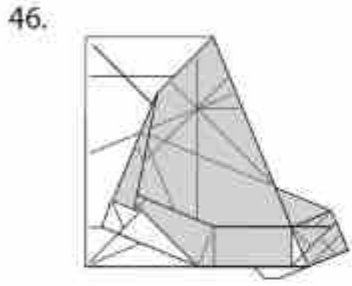
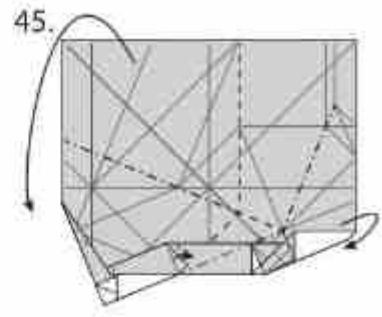

55.

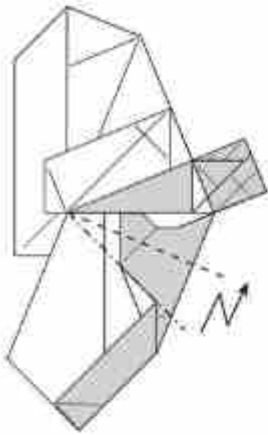

56.

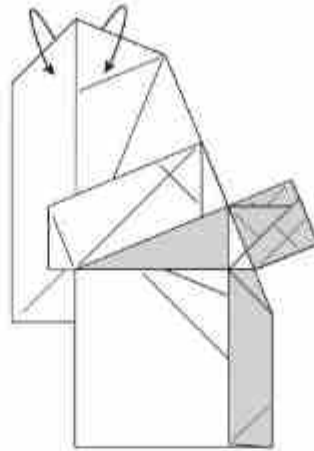

57.

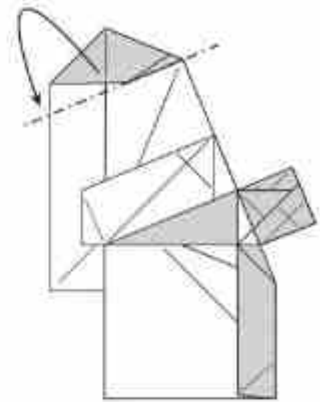

58.

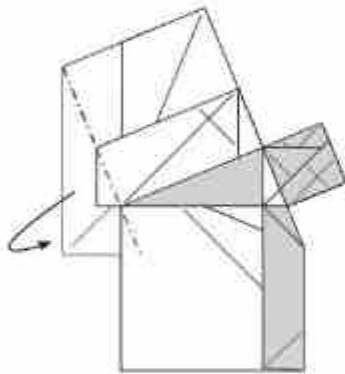

59.

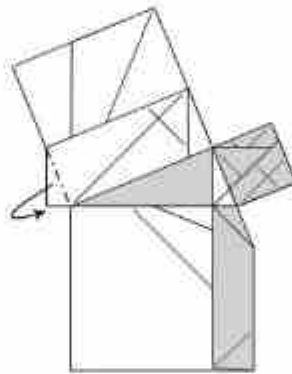

60.

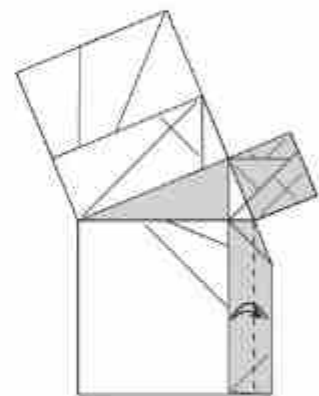

61.

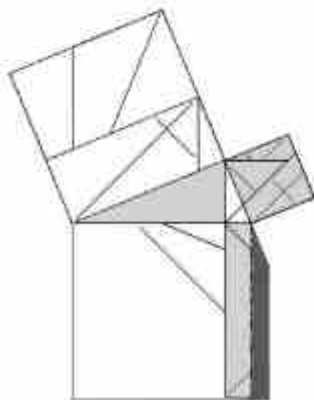

Closed sink

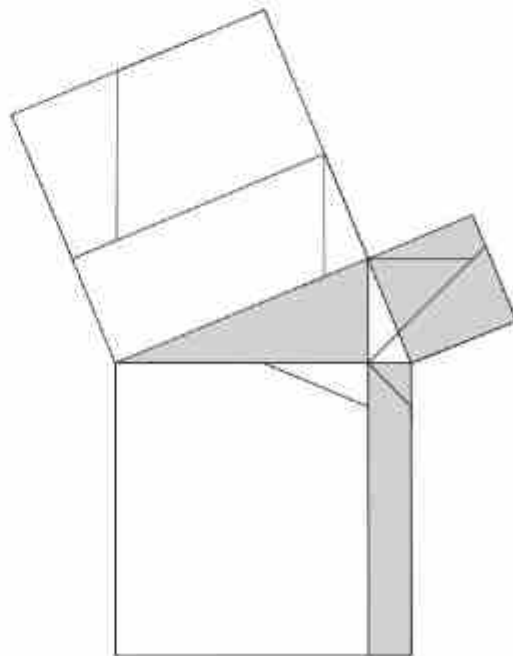

Model Complete

Origami

Basics

Line Styles

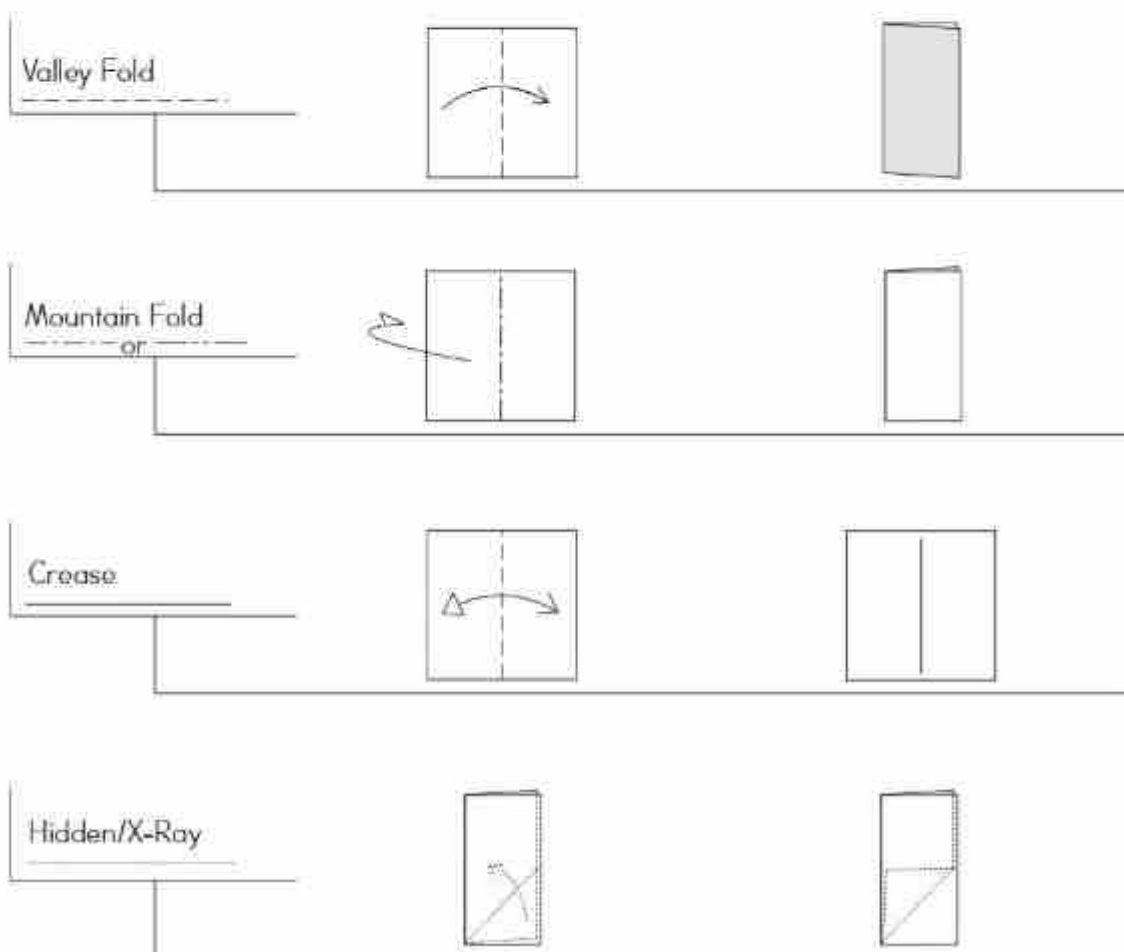

Arrows

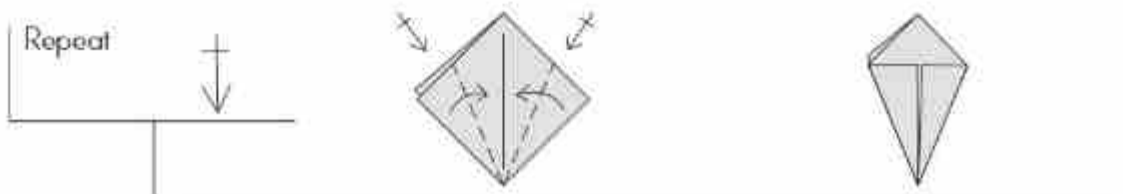
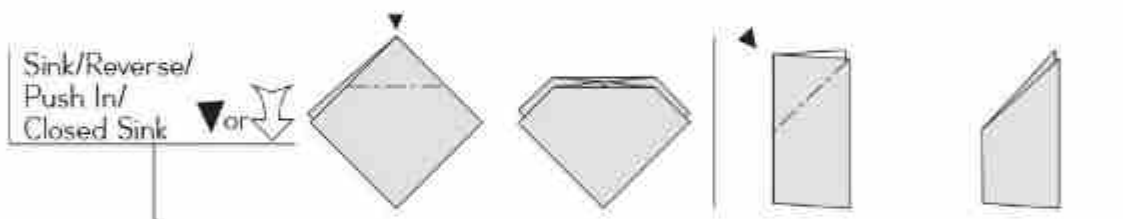
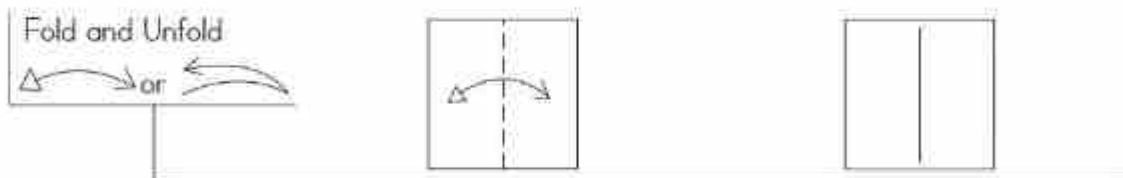
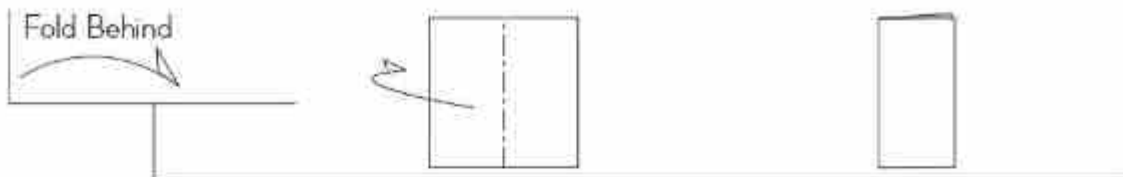
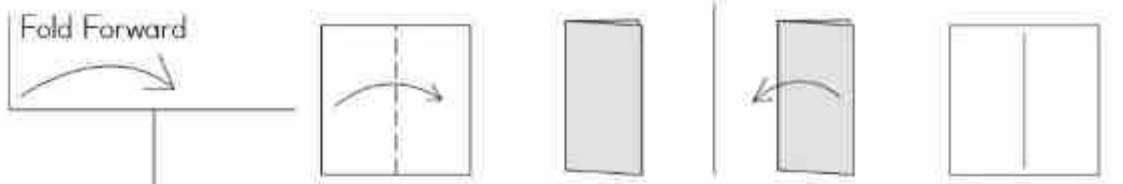

Maneuvers

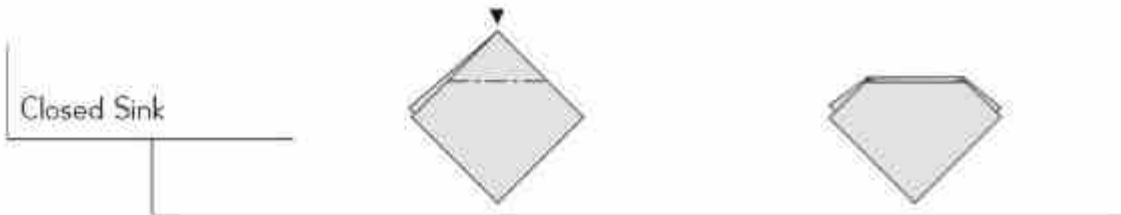
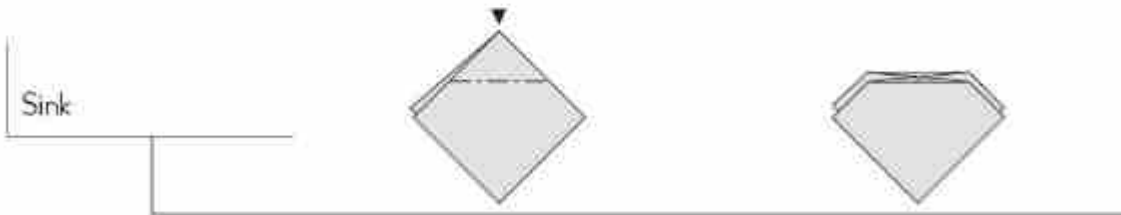
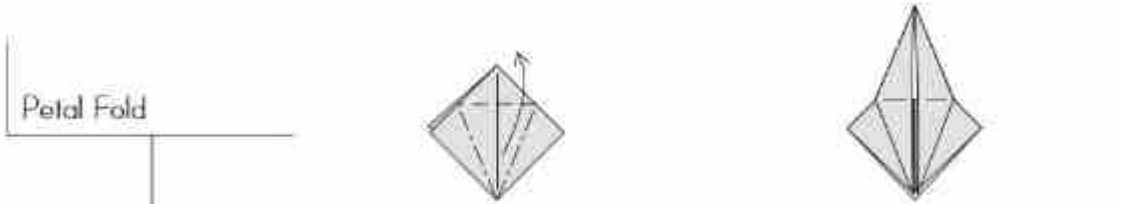
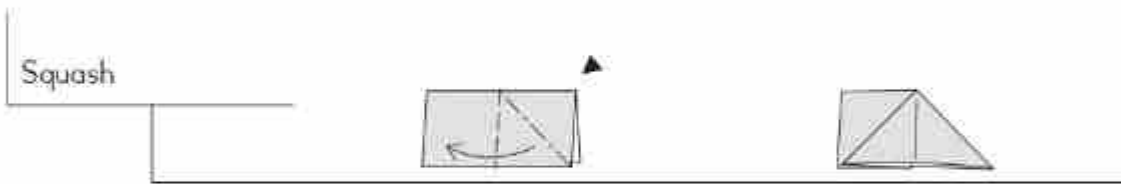
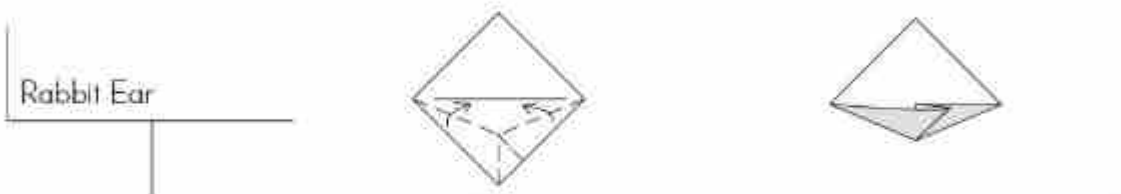
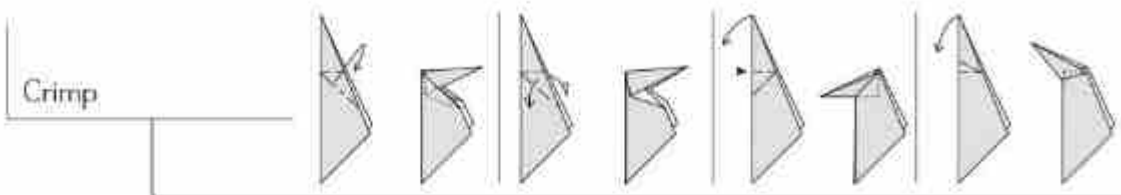
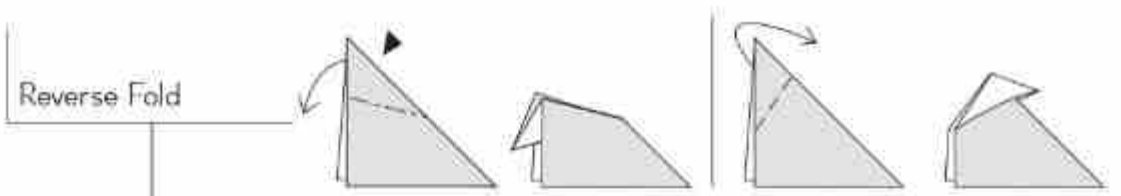

Common Bases

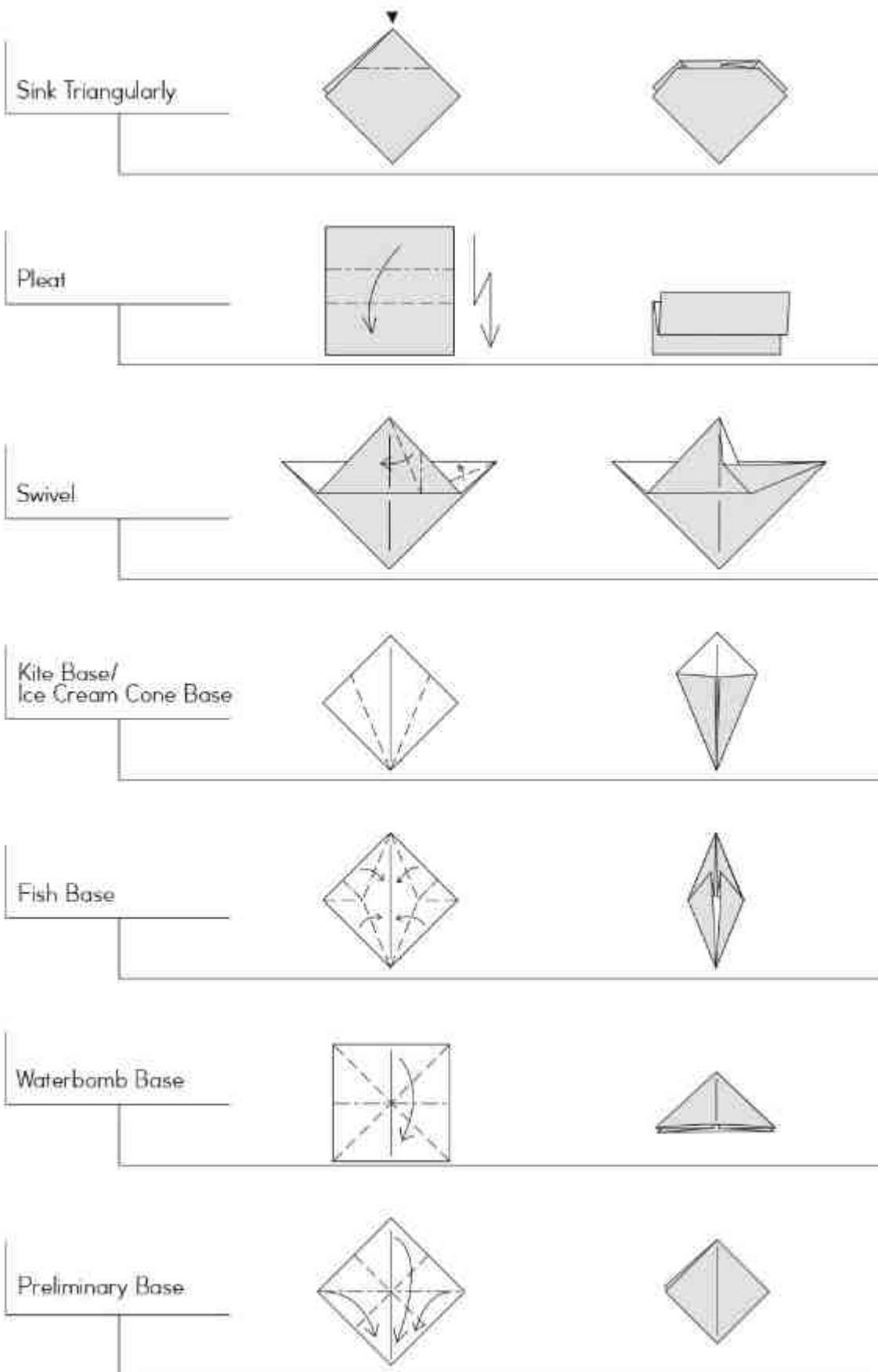

Bird Base

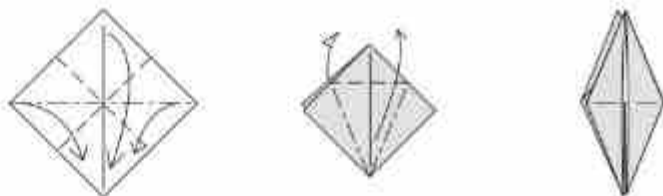

Frog Base/Lily Base

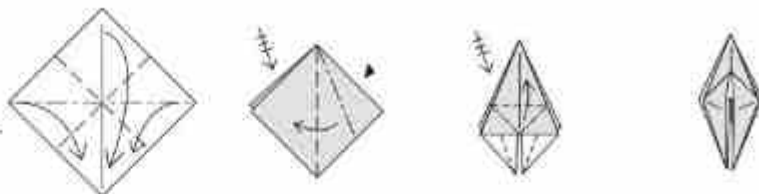

Windmill Base



Stretched Bird Base

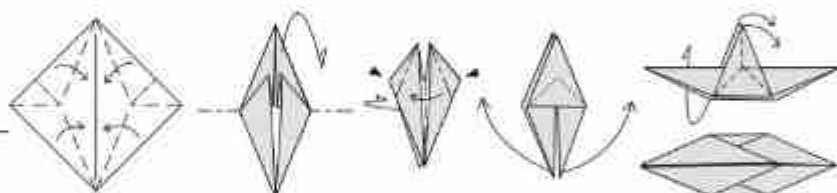

Blintzed Bird Base

