



6° CONVENCIÓN
ORIGAMI
ARGENTINA
TUCUMÁN 2022

LIBRO DE DIAGRAMAS

**Aquellos que amamos no se van,
caminan a nuestro lado todos los días.
Dedicamos este libro a nuestra querida
*Ceci Catuara***

Aquí de nuevo estamos de vuelta, "*después de larga ausencia*", como dice la zamba y estamos aquí, justamente en Tucumán, con el recuerdo de Cecilia, que tanto hiciera para llegar a este momento, a esta convención tan deseada y anhelada por ella en estas tierras, donde pudiera brindar junto a origami Tucumán todas las bondades de su querida provincia y de su hermoso grupo de plegado.

Esta convención, es especial, pensada junto a Ceci desde sus inicios y presente en cada momento de su organización desde su recuerdo y sus plegados.

Es una alegría enorme poder volver a encontrarnos y reencontrarnos en cálidos abrazos con los de siempre y conocer a los nuevos amigos que nos acompañan y que ocuparán un lugar en nuestros corazones.

Tuvimos que domar a ese "*toro mañero*" que nos hizo "*hacer un alto*" de dos años, pero traemos mil reuniones que, "*como leñita seca*" nos acompañaron casi diariamente durante el 2021.

Seguimos cantando como la calandria, seguimos plegando como gesto único y pleno de nuestro amor a este arte que nos congrega y nos reúne periódicamente, y ese, nuestro amor, como una estrella con corazón de papel, plegada contraluz, teselado, animalreflejo del sol que nos alumbra diariamente.

Traemos también más de mil papeles que transformaremos diariamente en recuerdos que ya palpitan y pliegan y se despliegan en abrazos y sonrisas, encuentros y amistades.

Después de tantos años de encuentros podemos hacer una corroboración científica: El origami en nosotros trabaja la coordinación corazón-mano eso que nadie podría lograr sin la presencia del otro, sin la presencia del nosotros.

Los invitamos a abrirle la reja a esa "*luna cautiva*" y a disfrutar de estos tres días de plegados y abrazos que nos esperan.

Saludos para todos, sean bienvenidos, ¡y a Plegar!

Comisión Directiva

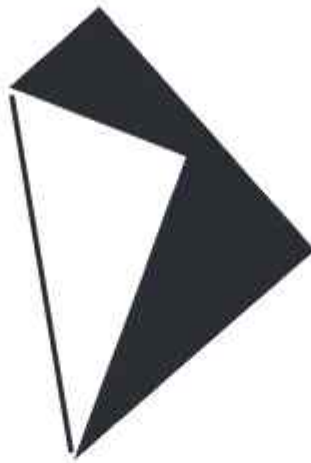

ORIGAMI
ARGENTINA

Asociación Civil
Plegando al Sur

Comisión Directiva

Presidente: *Alejo Wilkinson*

Vicepresidente: *Alejandra Naigeboren*

Secretaria: *Stella Ricotti*

Tesorero: *Miguel Gañan*

Vocales: *Gregorio Vainberg*

Maximiliano Ortiz

Marcos Gallo

Revisora de Cuentas: *Carolina Bazzana*

Índice

Nivel 1

Argentinian House / Michel Grand	12
Calochortus / Yara Yagi	14
Caracol / Coral Romá	17
Citrouille / Christophe Boudias	19
Elefante Títere de dedo / Coral Romá	20
Yoshi Daruma / Noemi Nohara	21
Cangrejo / David Tapias	22
Sirio / Pato Correa	25
Gori / Pato Correa	26
Gori - Gori / Pato Correa	27
1 2 3 Números / Graciela Vicente	28
Estrella Buenos Aires / Miguel A. Gañán	32
Estrella Zule / Guadalupe Martínez Arellano	34
Golla Star / Madhura Gupta	36
Gunda Star / Madhura Gupta	38
Filhote de Cachorro / Keila Correa de Paula	40
Guionna / Leticia Cruz Santos	41
Pañuelo Blanco / Lidia Eymann	43
Papá Noel / Mimi Nohara	45
Ratón / Manuel Carrasco	46
Rompecabezas Sorpresa / David Medina	47
Stella Floreale / Francesco Guarnieri	50
Tappy Star / Patrizia Porzio	52

Nivel 2

Juana / Maximiliano Ortiz	56
Mariela / Maximiliano Ortiz	58
Piedra Luminosa / Aldos Marcell	60
Bebé Dragón 1.0 / Francesco Massimo	64
Cerdito / Eszti Gyorik	67
Zorrito / Oz Neyer	71
Twirls Fortune / Krystyna Burczyk	75
Deca Star / Usman Rosyidhi	78
Tsuru de dos Cabezas / Allan Kenedy	80
Sun Star / Enrica Dray	83
Majo Star / Jonicley Macedo	85
Stella Frattale / Francesco Decio	87
Clic Clac / Paolo Bascetta	95

Nivel 3

Teselado Atolón / Miguel A. Gañán	100
Itik Pato / Rhanu Pradipta	104
Camaleón / Oz Neyer	108
Cardenal / Chistophe Boudias	111
Cumi Cumi / Rhanu Pradipta	114
Duende del Bosque / Xabier Sevillano	118
Leonszito / Eszti Gyorik	122
Pegaso Aleteador / Leonardo Pulido Martínez	125
Le Petit Ane / Christophe Boudias	129
Conejo / Francesco Massimo	132
Ardilla / Francesco Massimo	135
Sea Horse / Leonardo Pulido Martínez	140

Invitados

Beija / Flaviane koti	145
Borbolela / Flaviane koti	147
Rosa del Desierto / Flaviane koti	149
Azaleia / Flaviane koti	151
Kusudama Vórtex / Flaviane koti	152
Baby Gorilla / Fernando Chura	155
Conejo / Fernando Chura	160
Gacela de Clark / Fernando chura	164
Mandala Marielita / David Martínez	174
Tesela / David Martínez	175
Verum Flower / David Martínez	177



**ORIGAMI
ARGENTINA**

Asociación Civil Plegando al Sur

**6^o CONVENCION
DE ORIGAMI
ARGENTINA**

TUCUMÁN 2022

Nivel 1

Argentinian House / Michel Grand

Diag : Christophe CURAT 02/2022

Variation d'un modèle
de Shun'ichi ASHIMURA

⊙ rectangle 1 x 2
80 g/m² recommandé

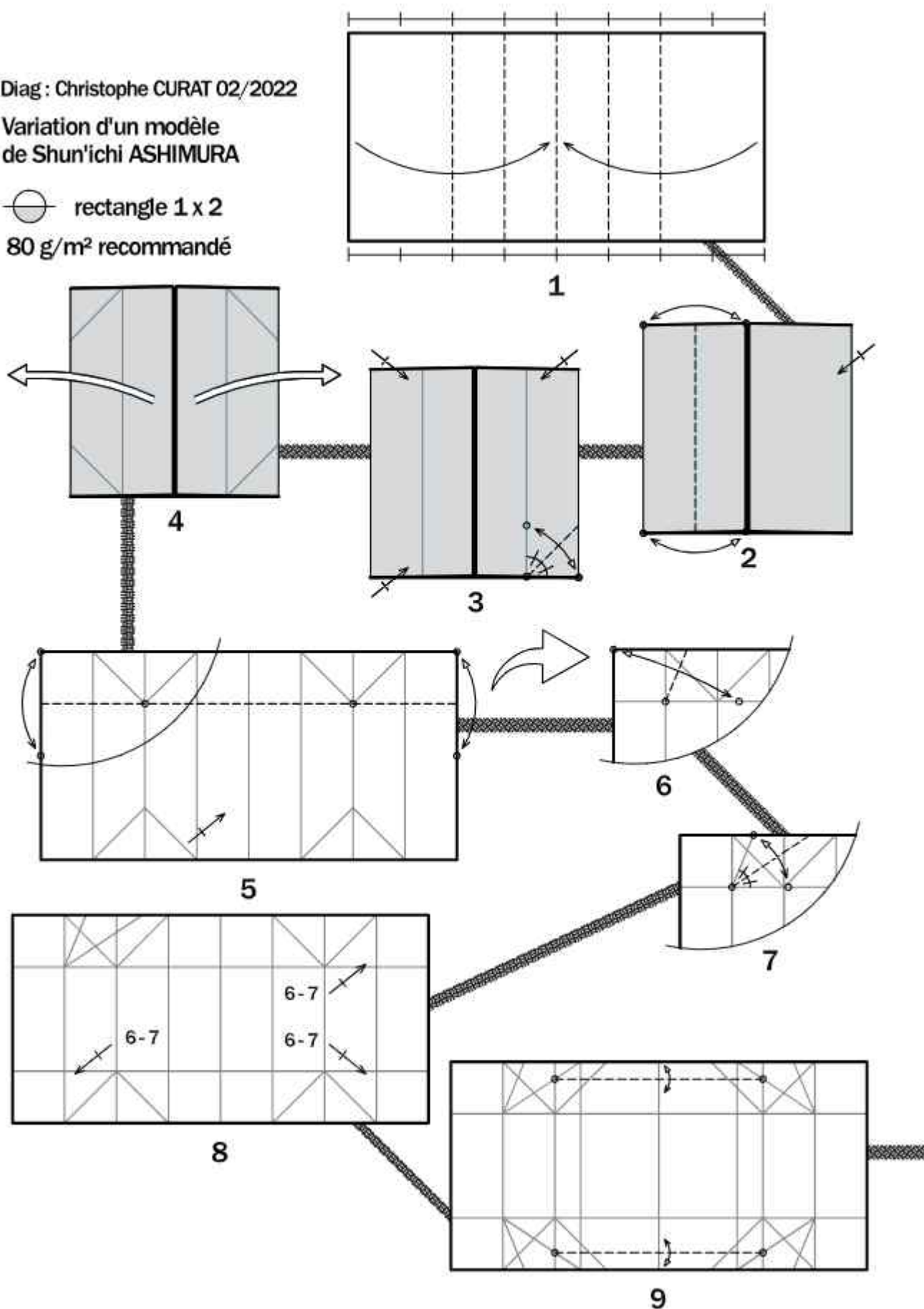

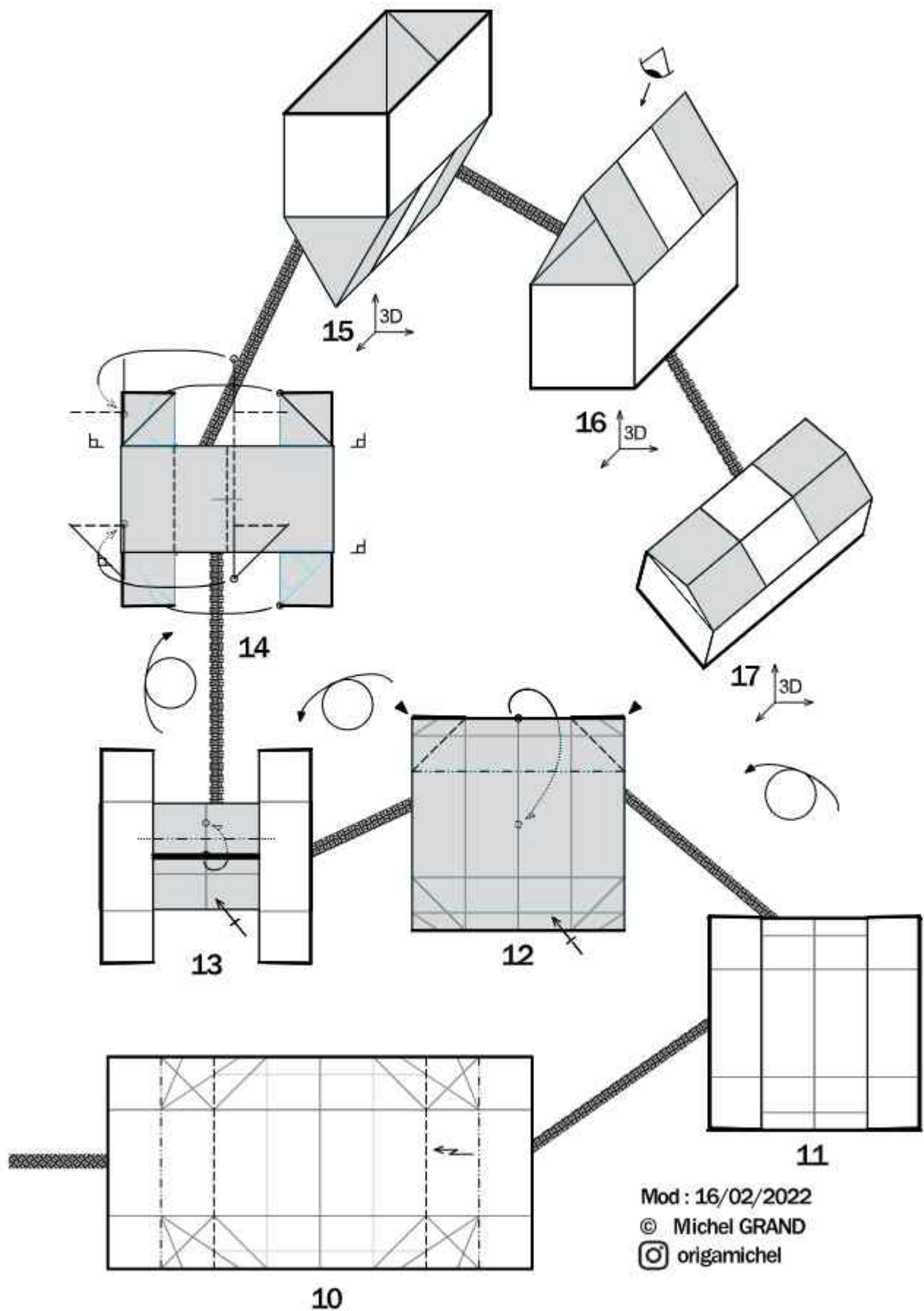

Calochortus

Creación y diagramas: Yara Yagi

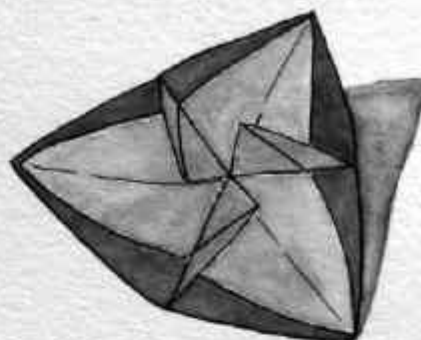

Trés cuadrados de 7,5cm

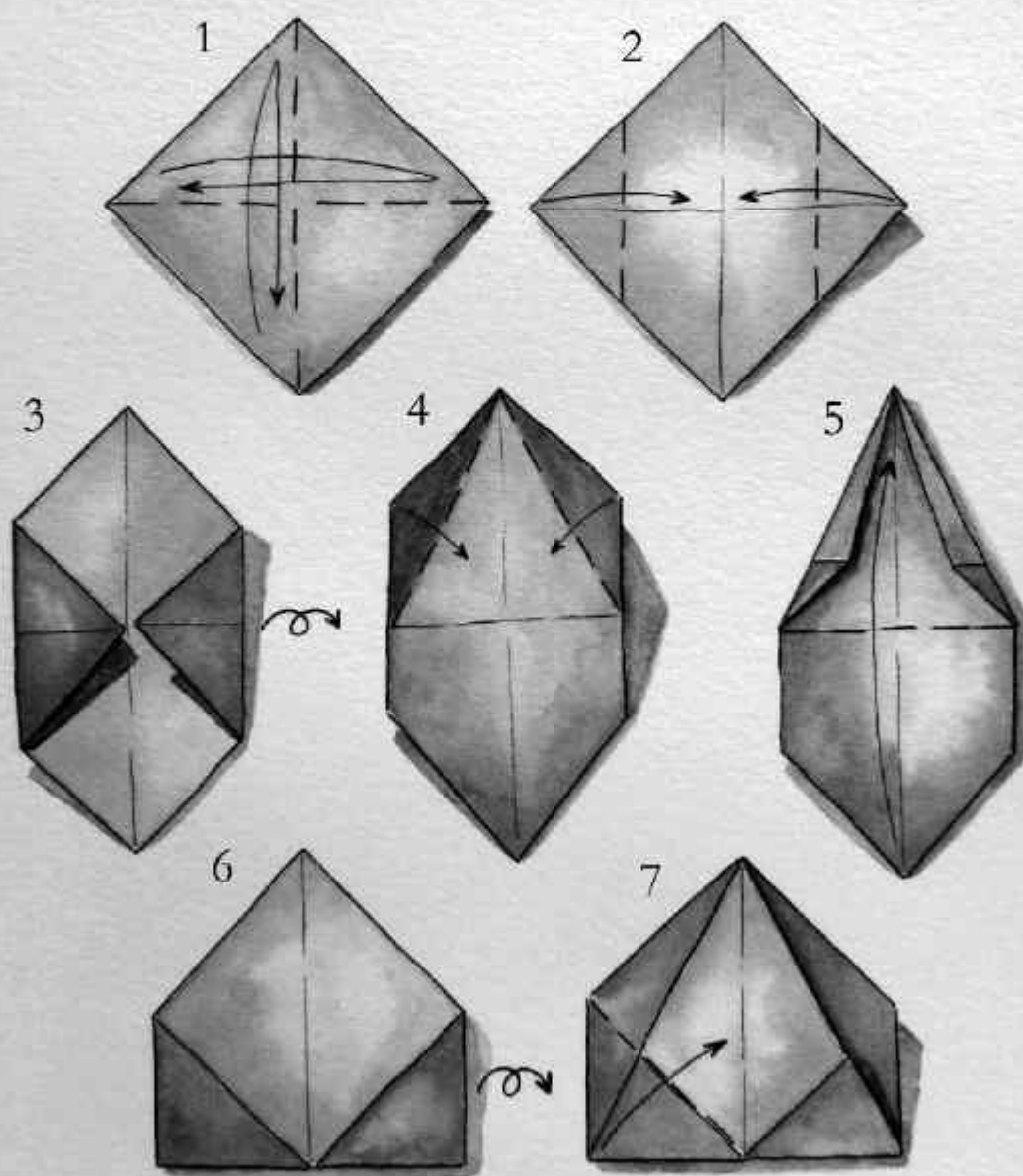

8

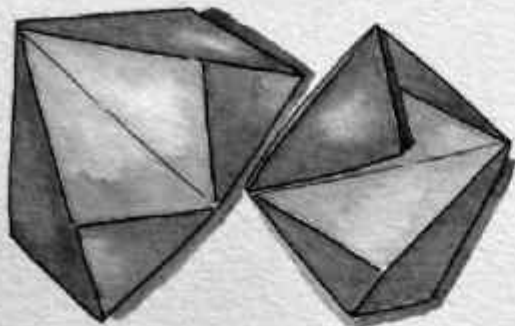

ensamblar

9

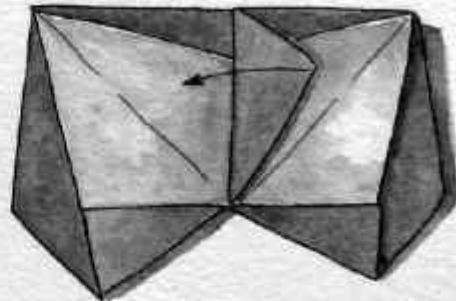

10

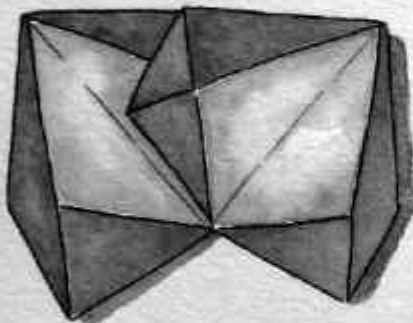

repetir

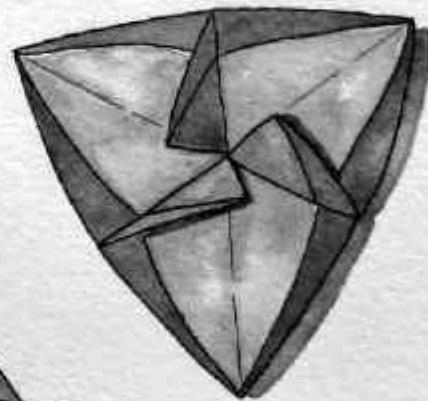

Variaciones

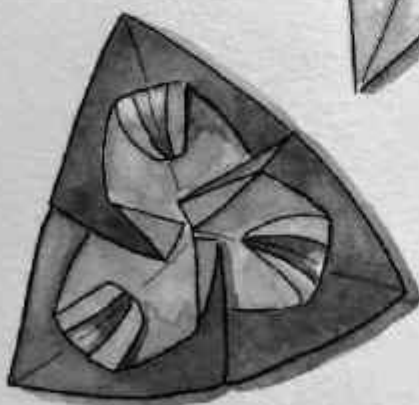
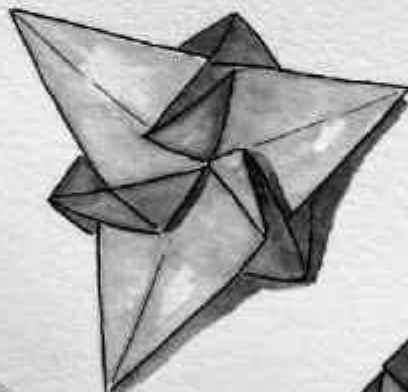

variaciones

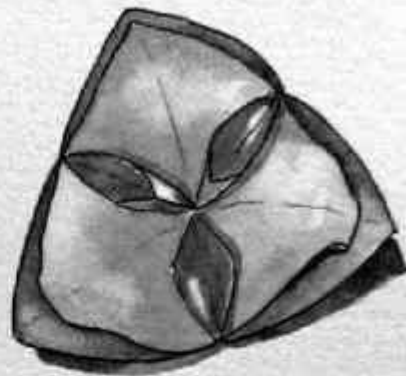
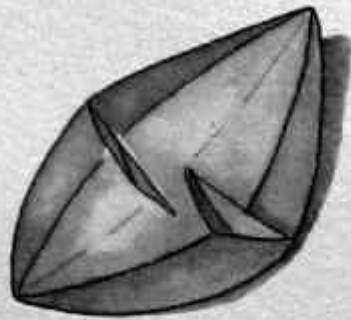

1

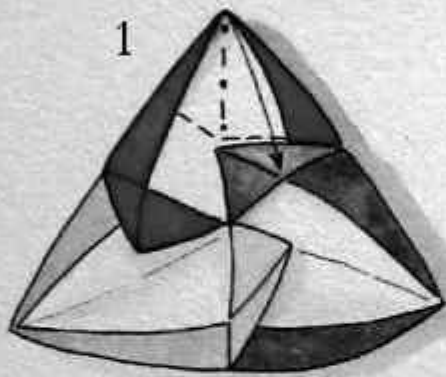

Otra varación

2

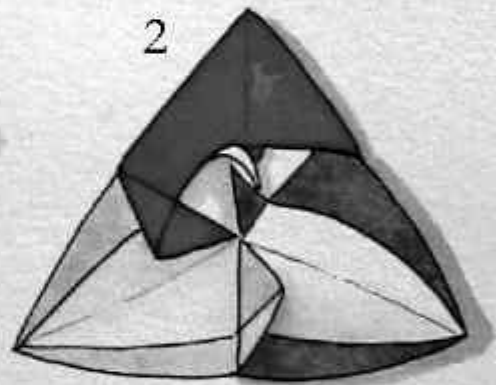

3

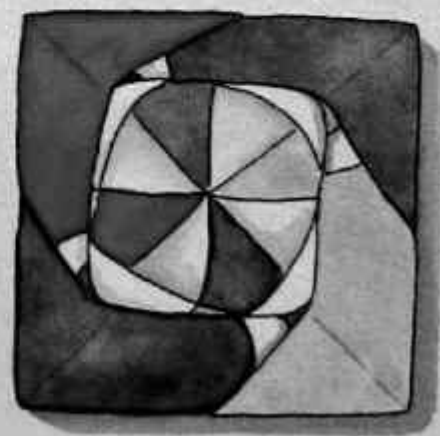
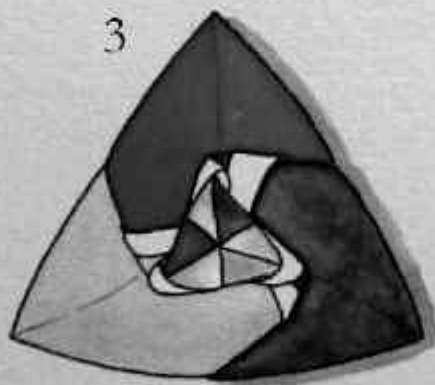

Con 4 módulos

Caracol / Coral Romá

Diagrama (*Diagram*): Origamileo

Paper: 4 x 1 

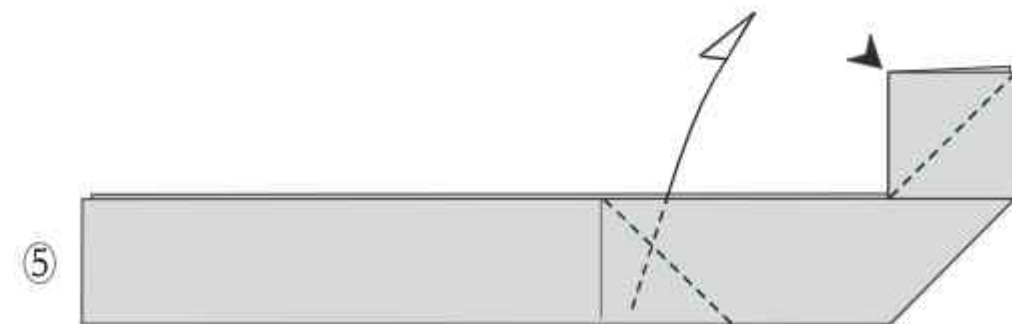
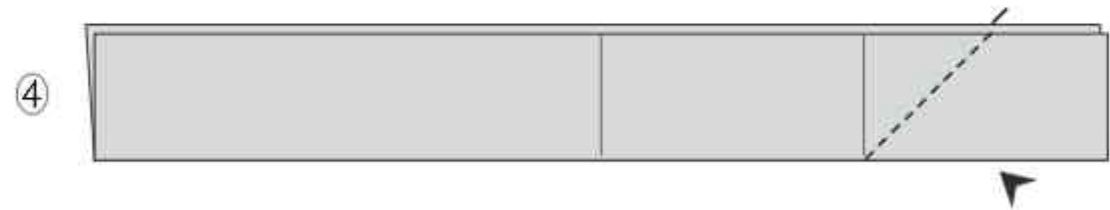
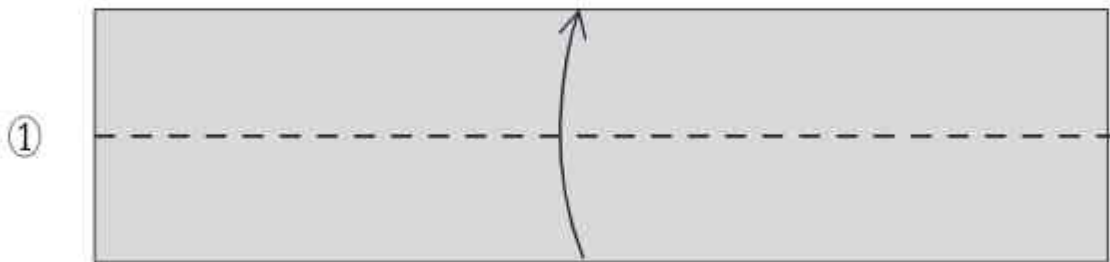
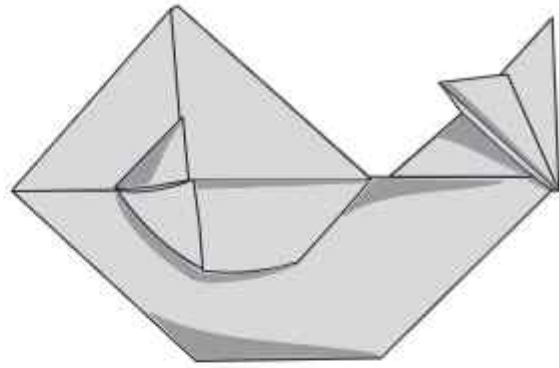

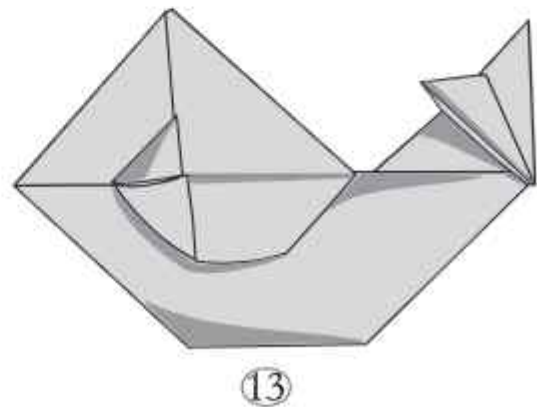
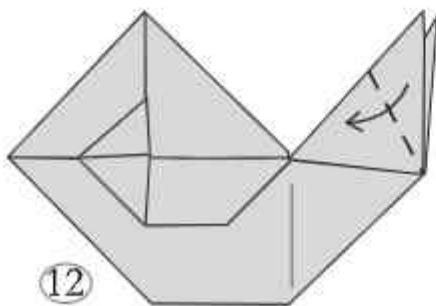
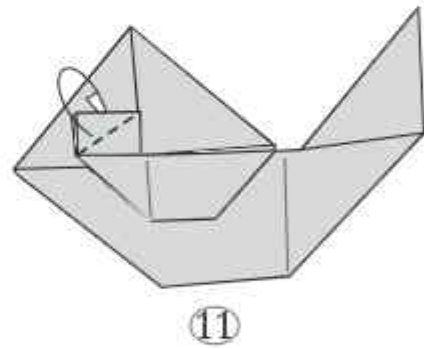
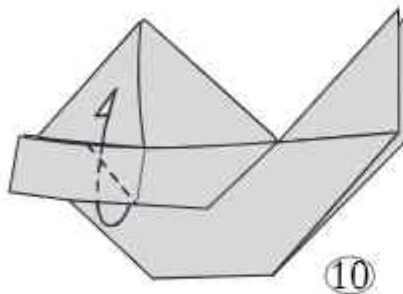
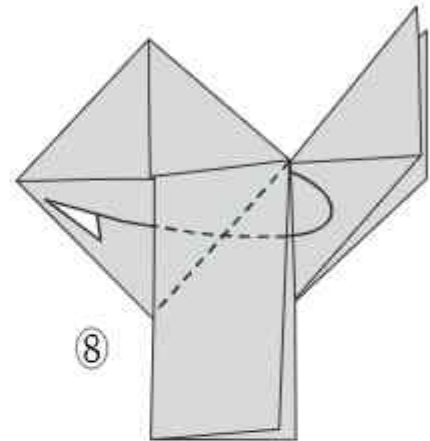
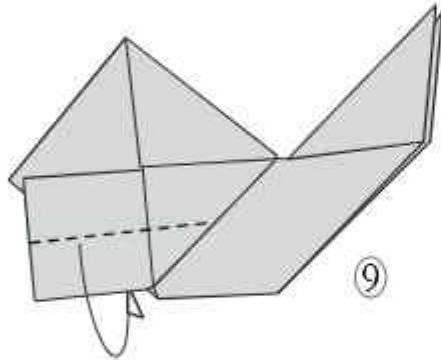
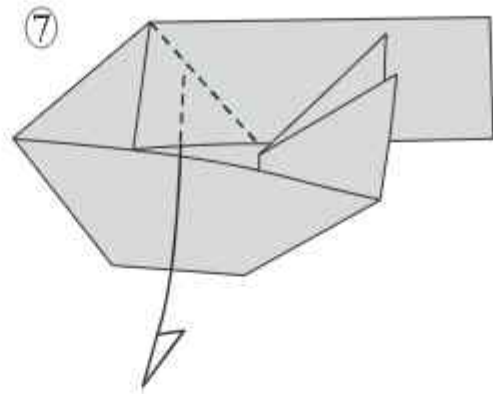
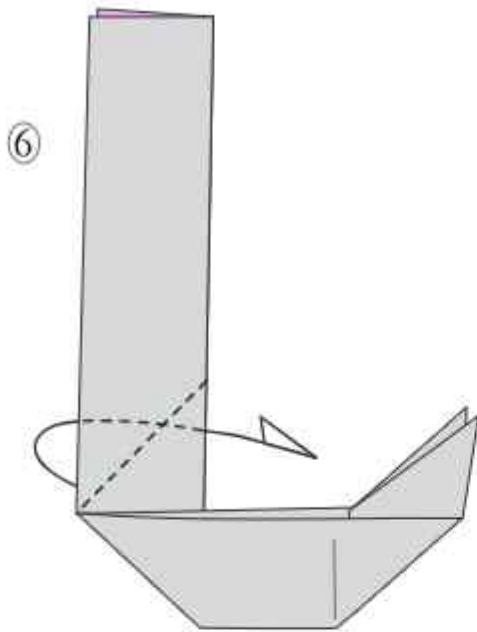

Citrouille / Christophe Boudias



Modèle et Diagramme :
Christophe Boudias ;-)

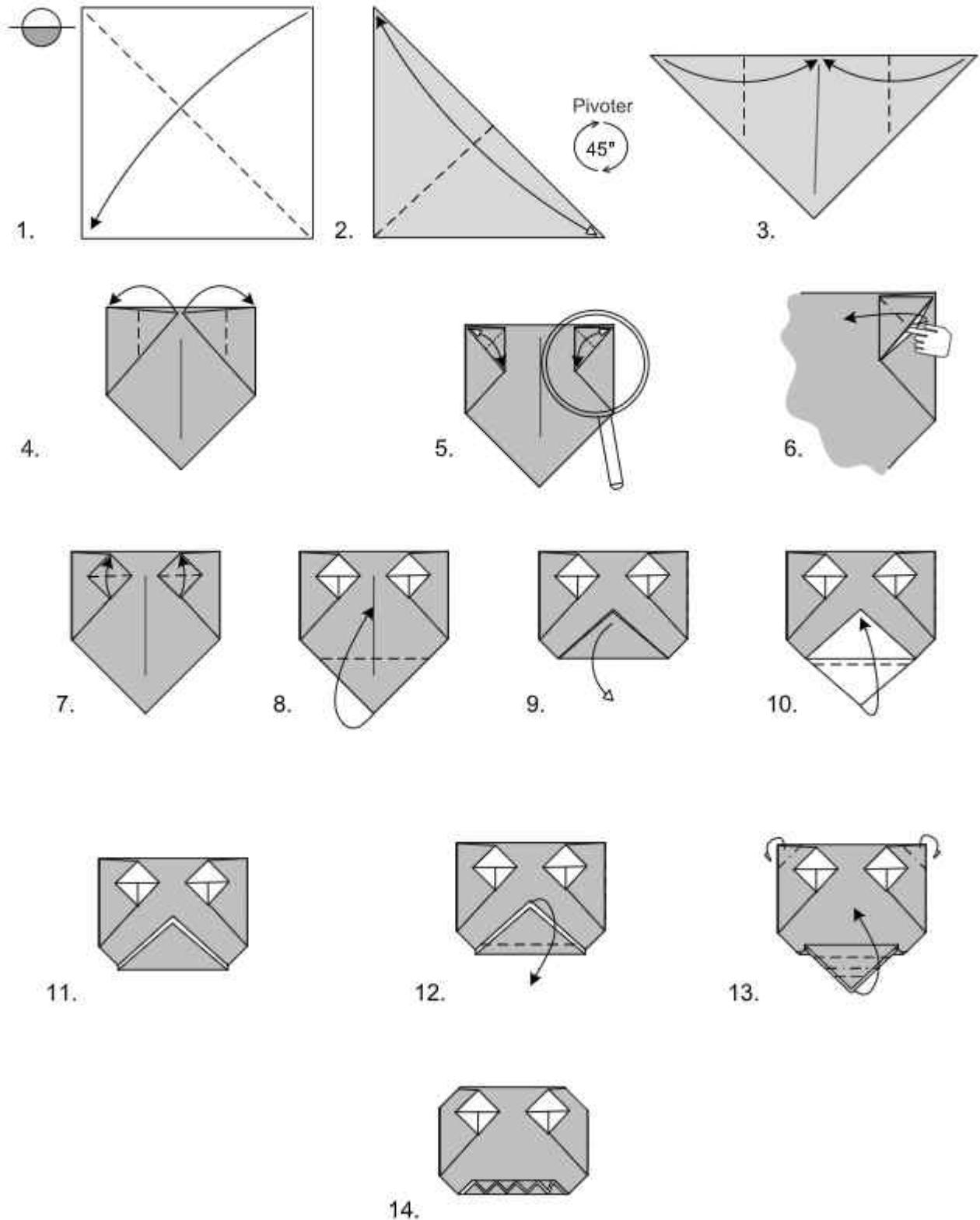

Elefante Títere de dedo / Coral Romá

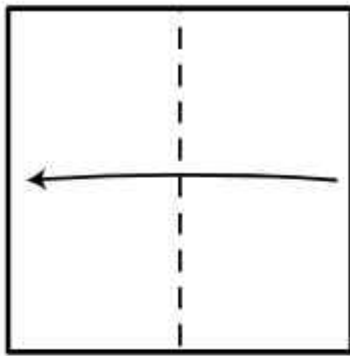

1) Plegar por la mitad hacia la izquierda.



Attribution-NonCommercial-ShareAlike 4.0 International

Obra de arte: Nick Robinson

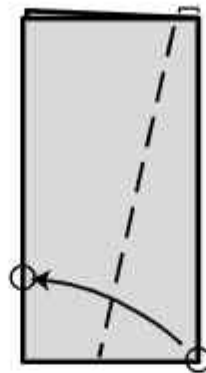

2) Fijarse en el espacio que hay que dejar en la parte superior, plegar uniendo los círculos y desplegar.

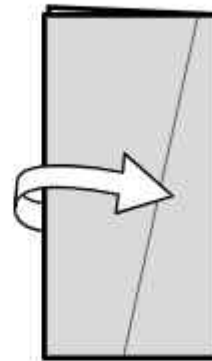

3) Desplegar.

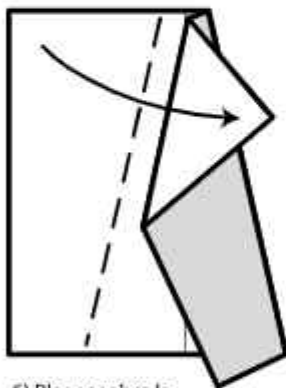

4) Plegar sobre la cicatriz ya existente.

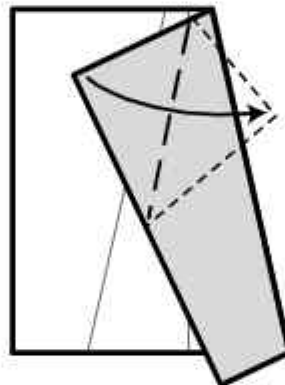

5) Plegar para que coincida con la línea punteada.

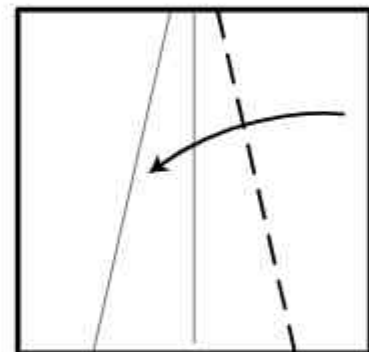

6) Plegar sobre la cicatriz ya existente.

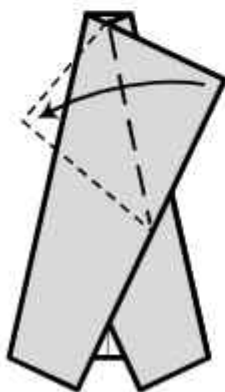

7) Plegar para que coincida con la línea punteada.

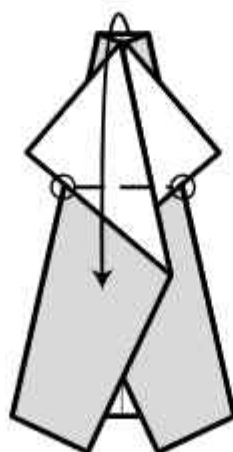

8) Plegar hacia abajo.



9) ¡Dibujar los ojos!

Yoshi Daruma / Noemi Nohara

Autor: Noemi Nohara
02.01.2022
@tiendayoshiyoshi



YOSHI DARUMA

Amuleto japonés de la Buena suerte
Símbolo de la perseverancia.
Guardián de tu objetivo, meta o propósito.

1. Piensa en una meta, objetivo y luego pintarle su ojo izquierdo.
2. El daruma te motiva a que sigas tu camino
3. Cuando alcances tu meta, pinta su otro ojo.

Cangrejo / David Tapias

Modelo: 11/2020 , Diagrama: 05/2022
Papeles recomendados: Kami ,15x15 cm
Nivel: Inicial
Diagramado por: David Tapias
origami.davidtapias.com, @davidtapiasorigami



1

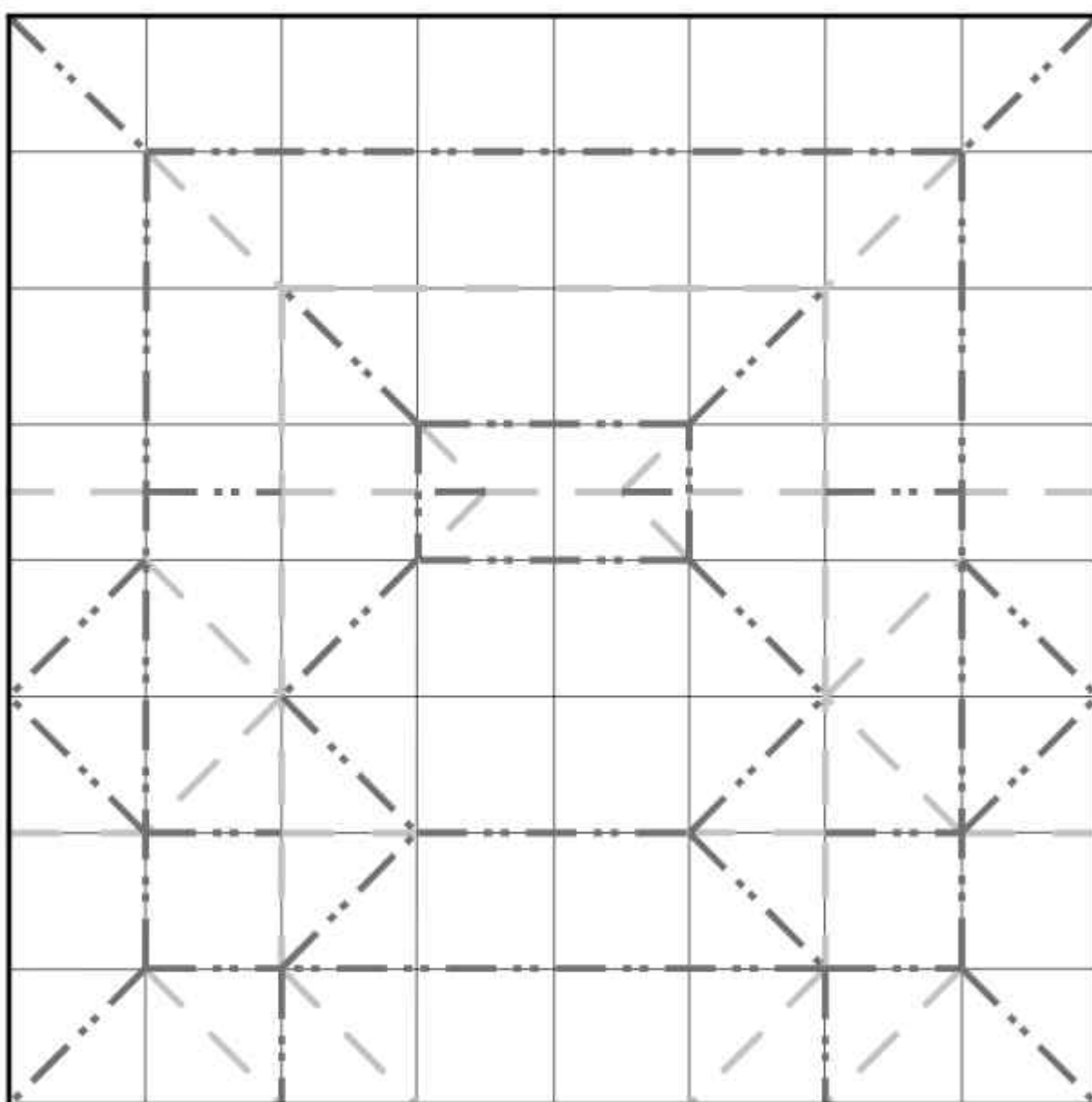

2

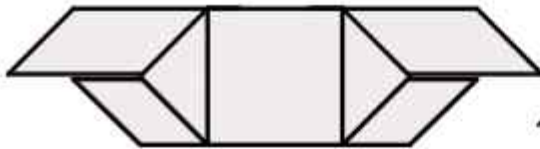

Vista superior.

3

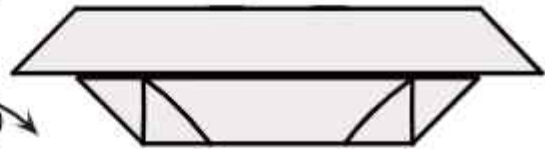

Vista inferior.

4

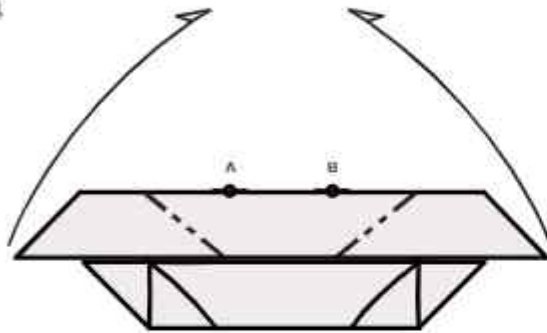

Plegar en montaña, hasta los puntos A y B.

5

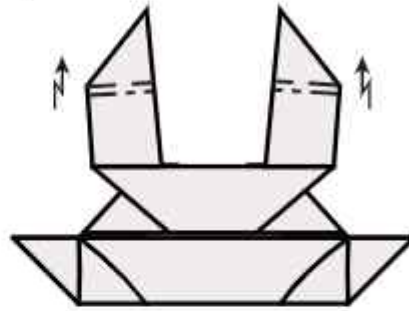

Hacer zig zag.

6

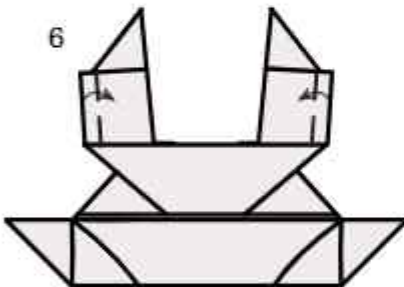

7

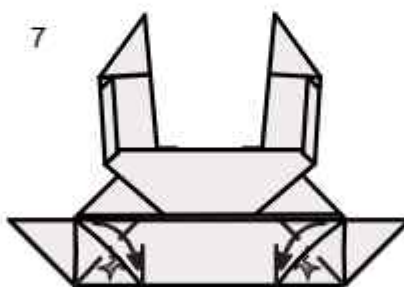

Abrir los bolsillos y plegar como se indica.

8

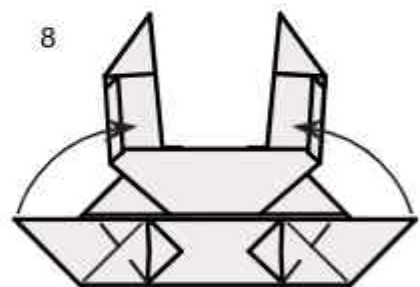

9

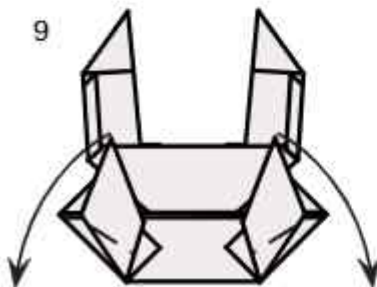

Bajar puntas en valle, se creará un nuevo pliegue. Ver paso 10.

10

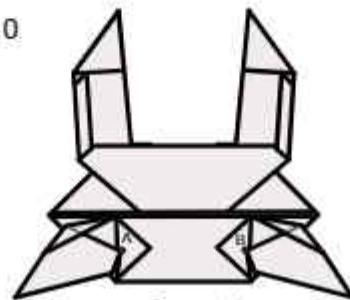

Rayos X, Insertar A y B en los bolsillos

11

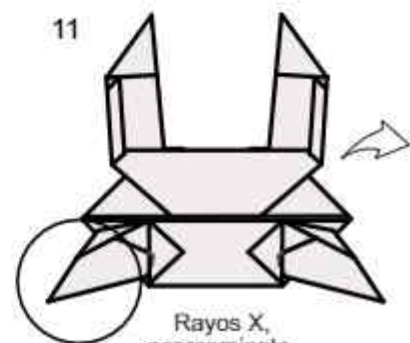

Rayos X, acercamiento.

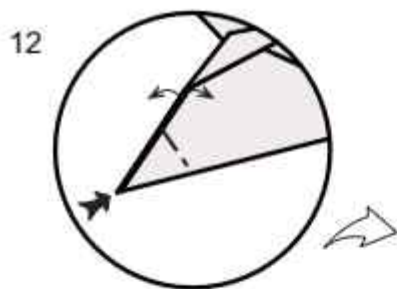

Abrir las capas y hundir la punta como se indica.

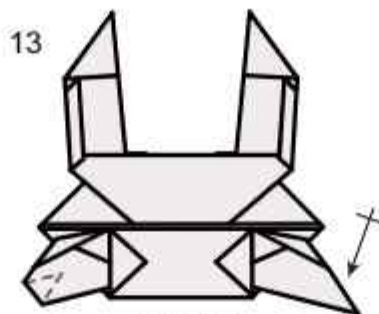

Rayos X, Repetir el paso 12.

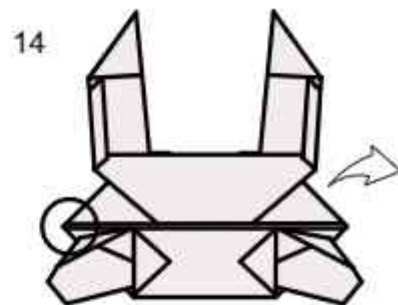

Acercamiento.

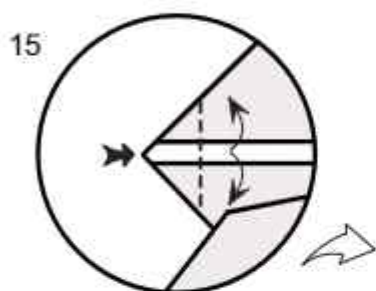

Abrir y ocultar la punta como se indica.

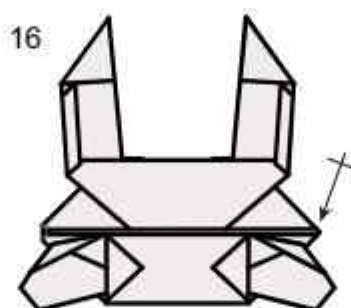

Rayos X, Repetir el paso 15.

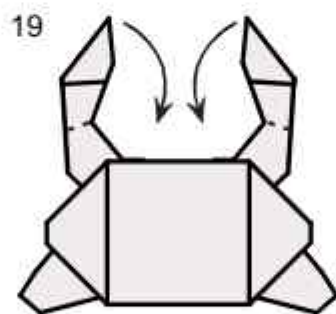
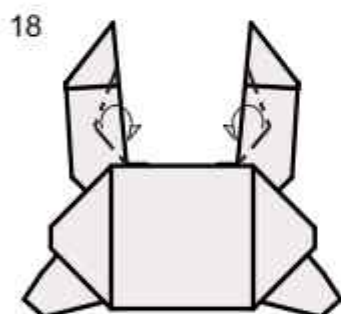
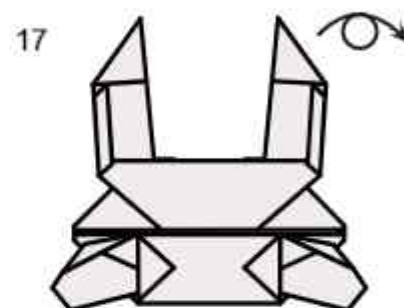

Plegar en montañía con fuerza para bajar las tenazas.

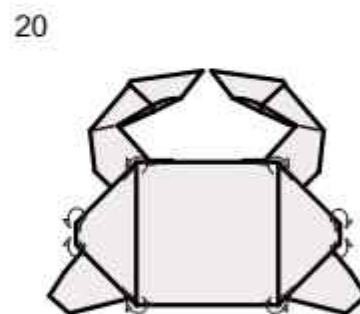

Redondear el cuerpo.

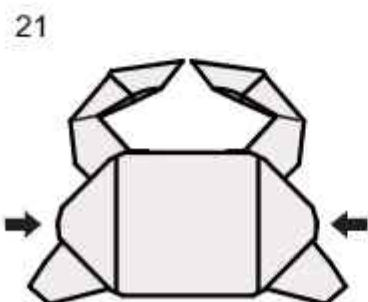

Oprimir a los lados para dar volumen, se levantarán las tenazas.



Terminado.

Sirio / Pato Correa

"Sirio"
Estrella modular
de Pato Correa

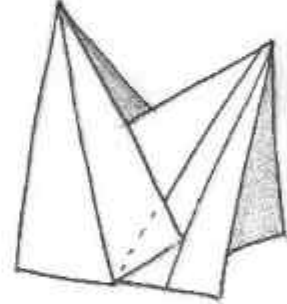
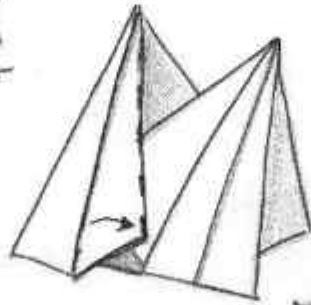
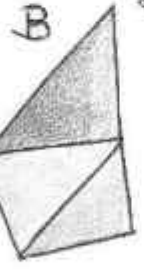
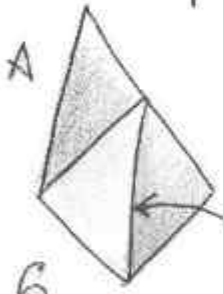
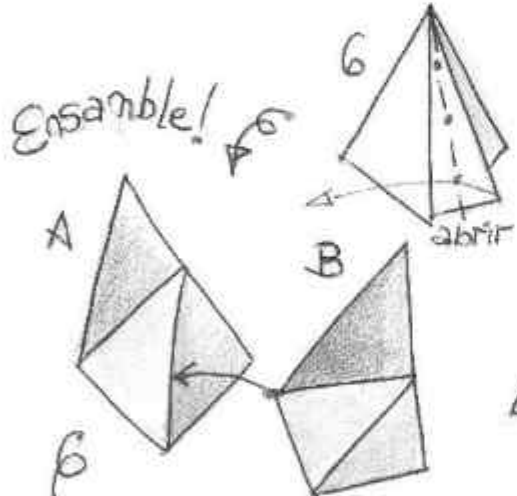
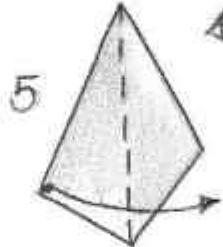
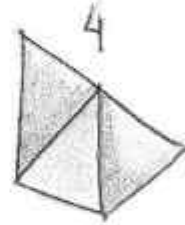
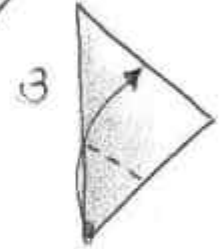
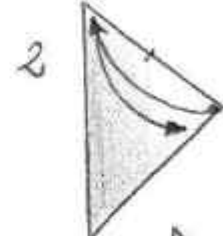
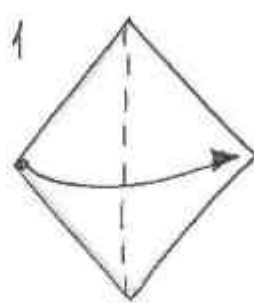
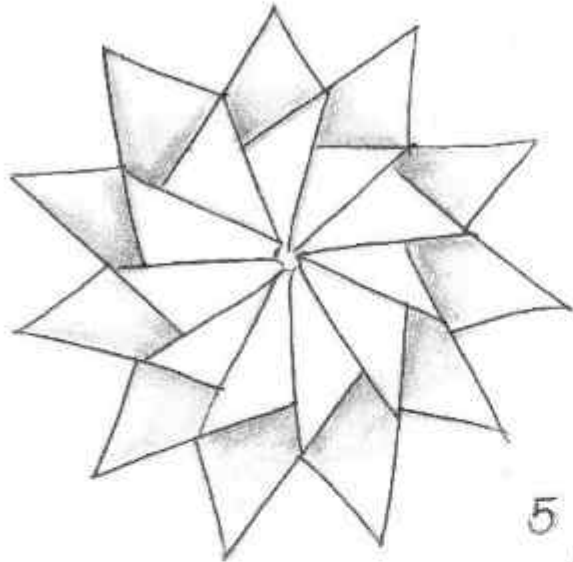

unir
todos
los
módulos

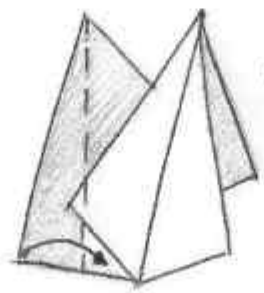
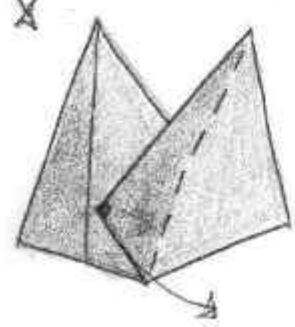

10/11 módulos

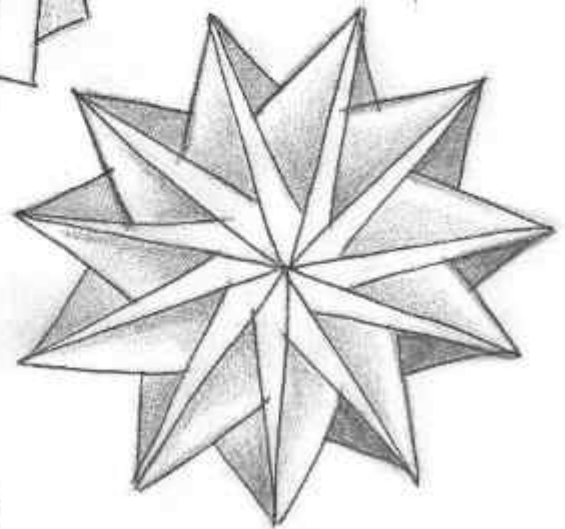

Gori / Pato Correa

8 □
 ↻ ⊖

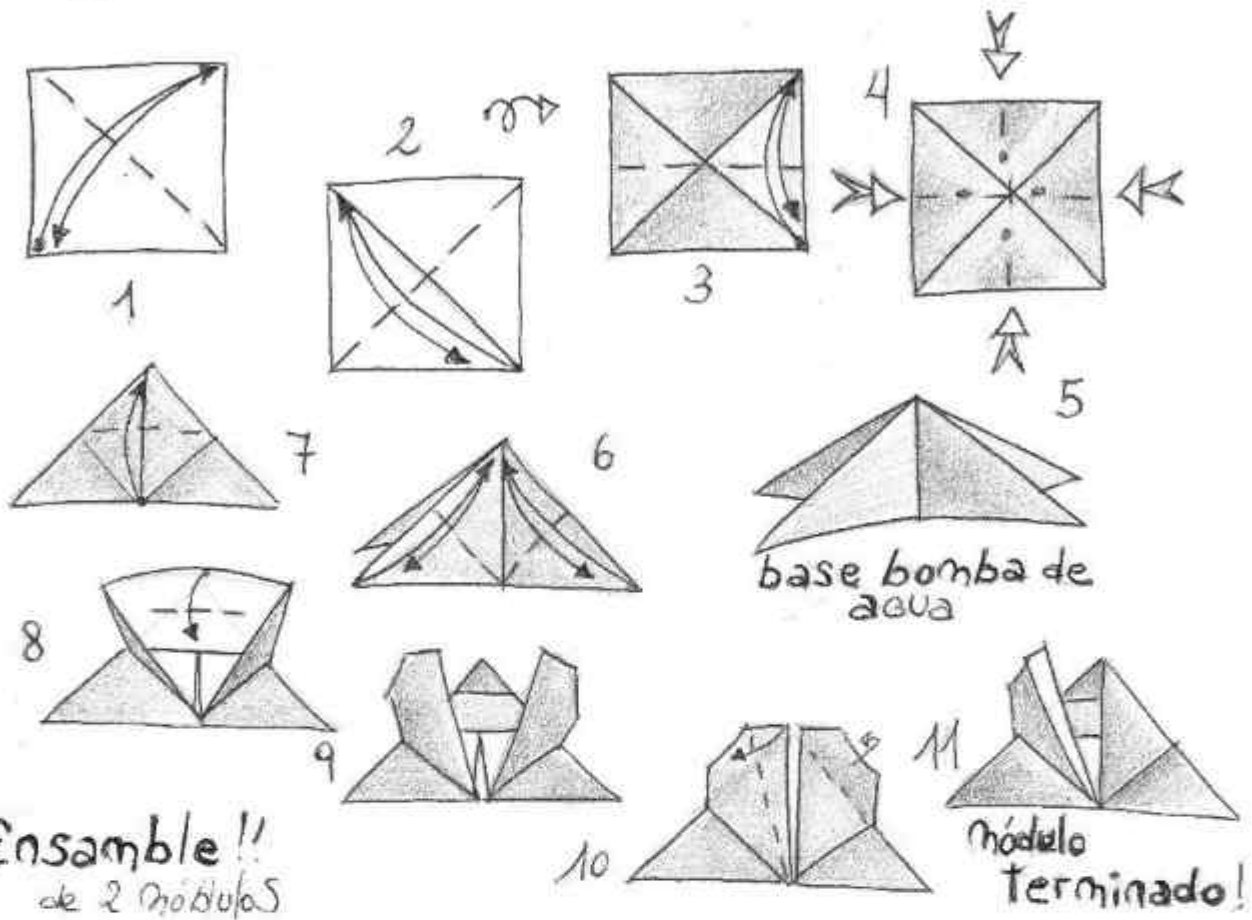

Ensamble!!
 de 2 módulos

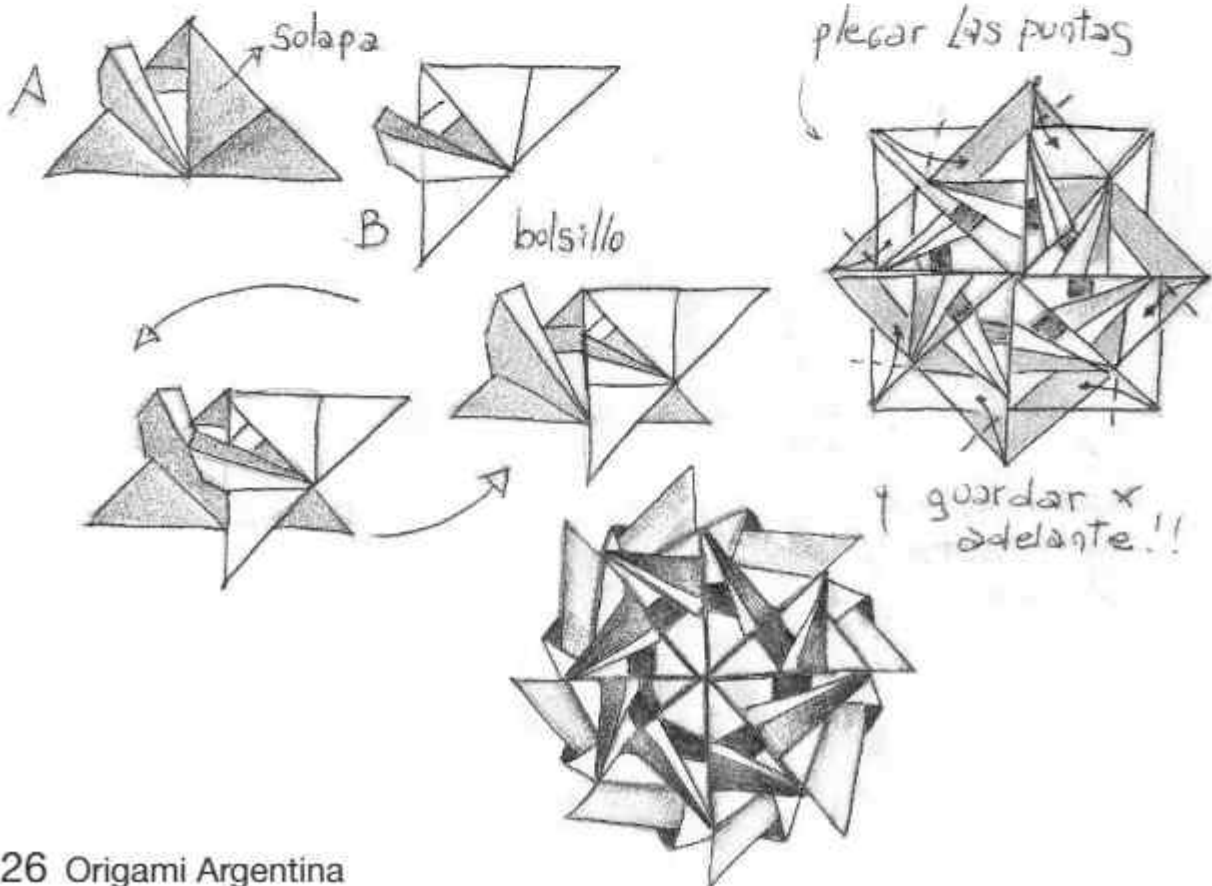

Gori - Gori / Pato Correa

8 Módulos

ESTRELLA "GORI-GORI" de Pato Correa

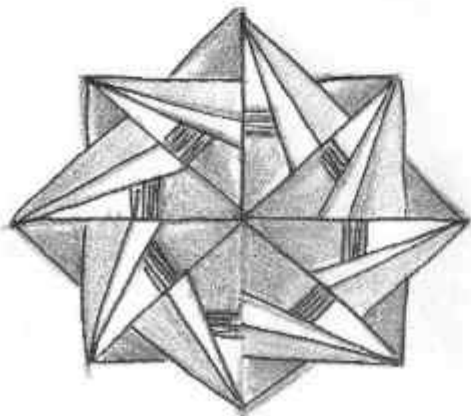
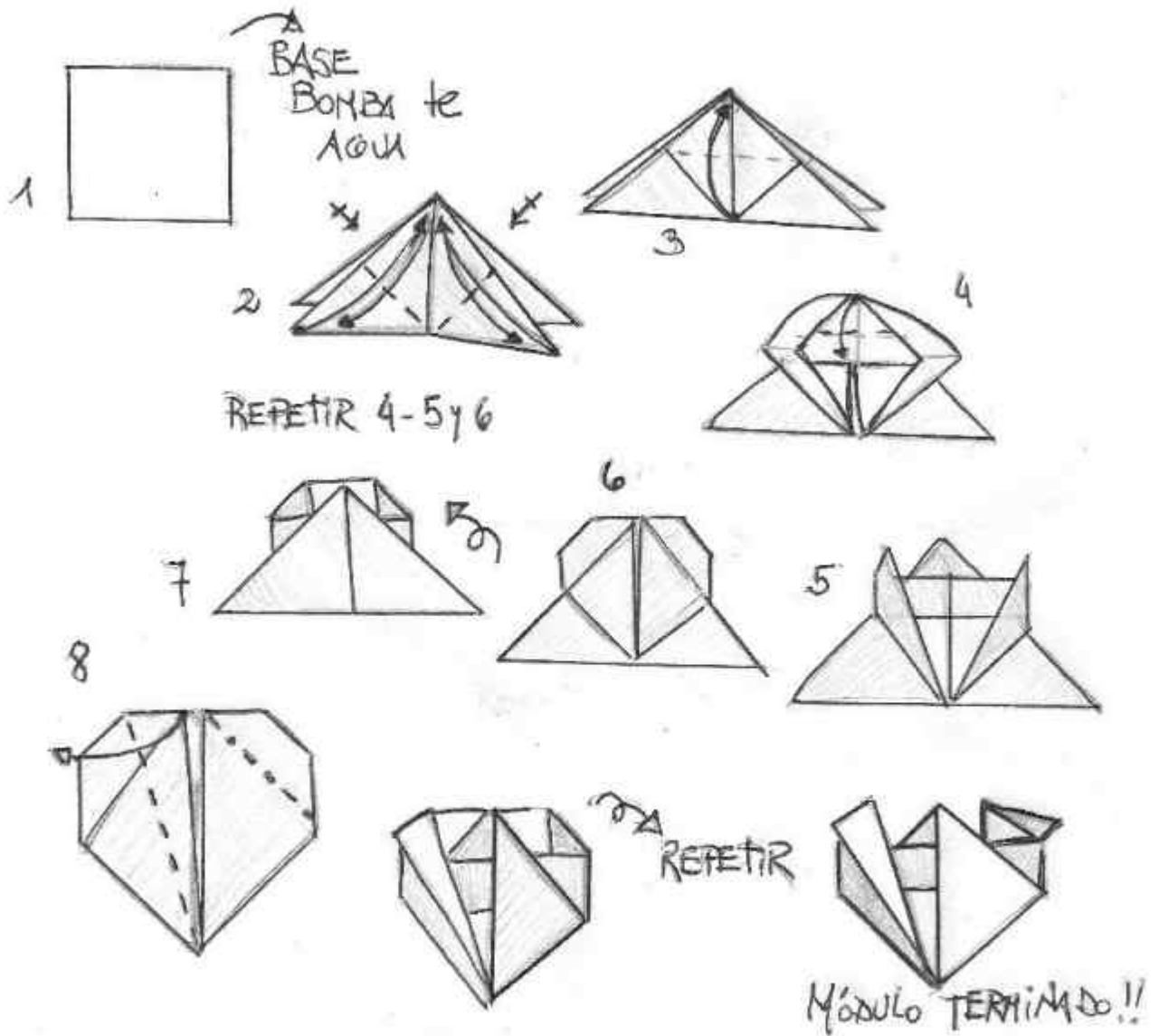

Ensamble

Ver GORI!!
y repetir adelante
y ATRÁS

1 2 3 Números / Graciela Vicente

La idea de esta serie fue diseñar unos números solamente con dos pliegues y después desarrollar el diseño hasta lograr un número más complejo, pero siempre partiendo de la misma base.

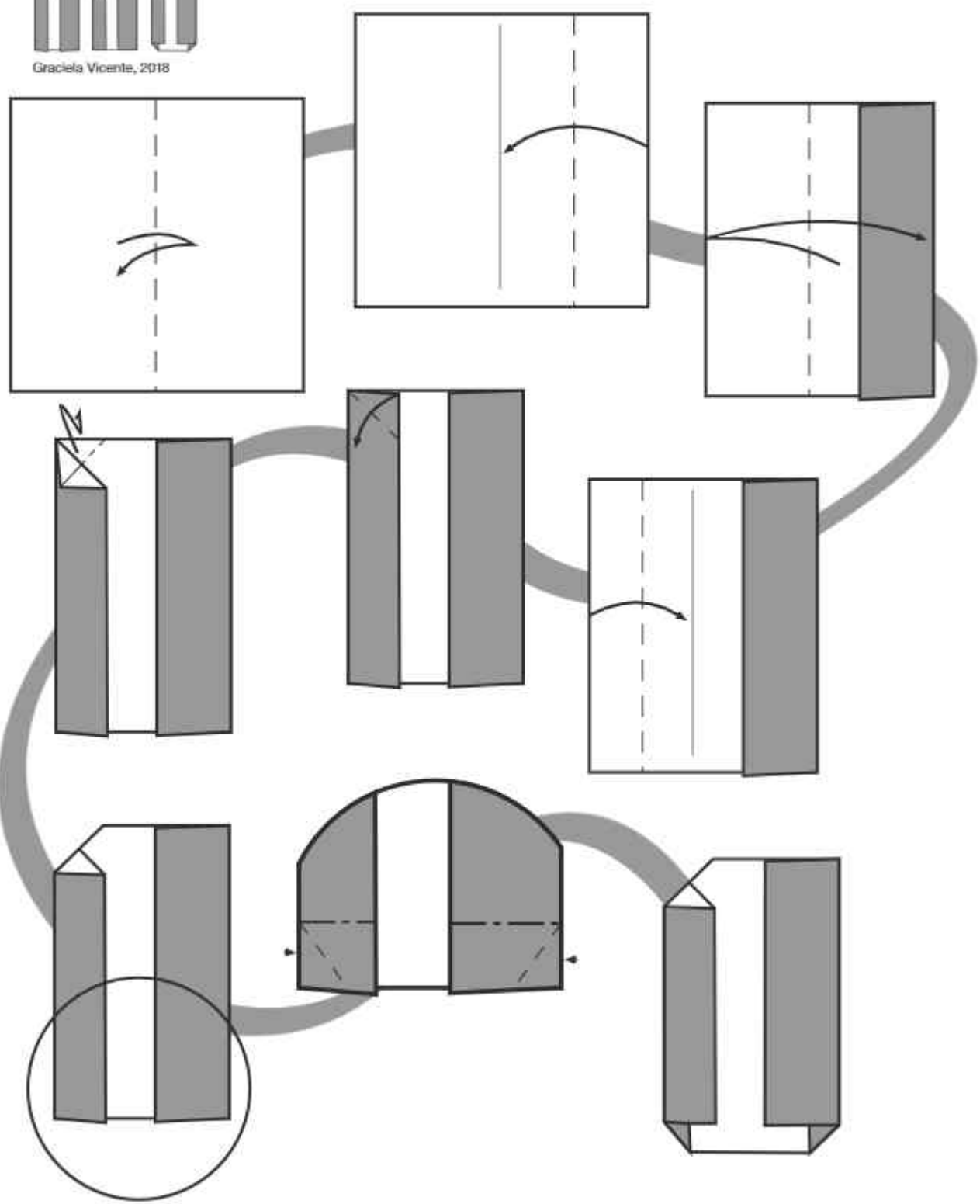
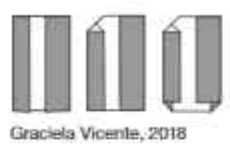



Graciela Vicente, 2018

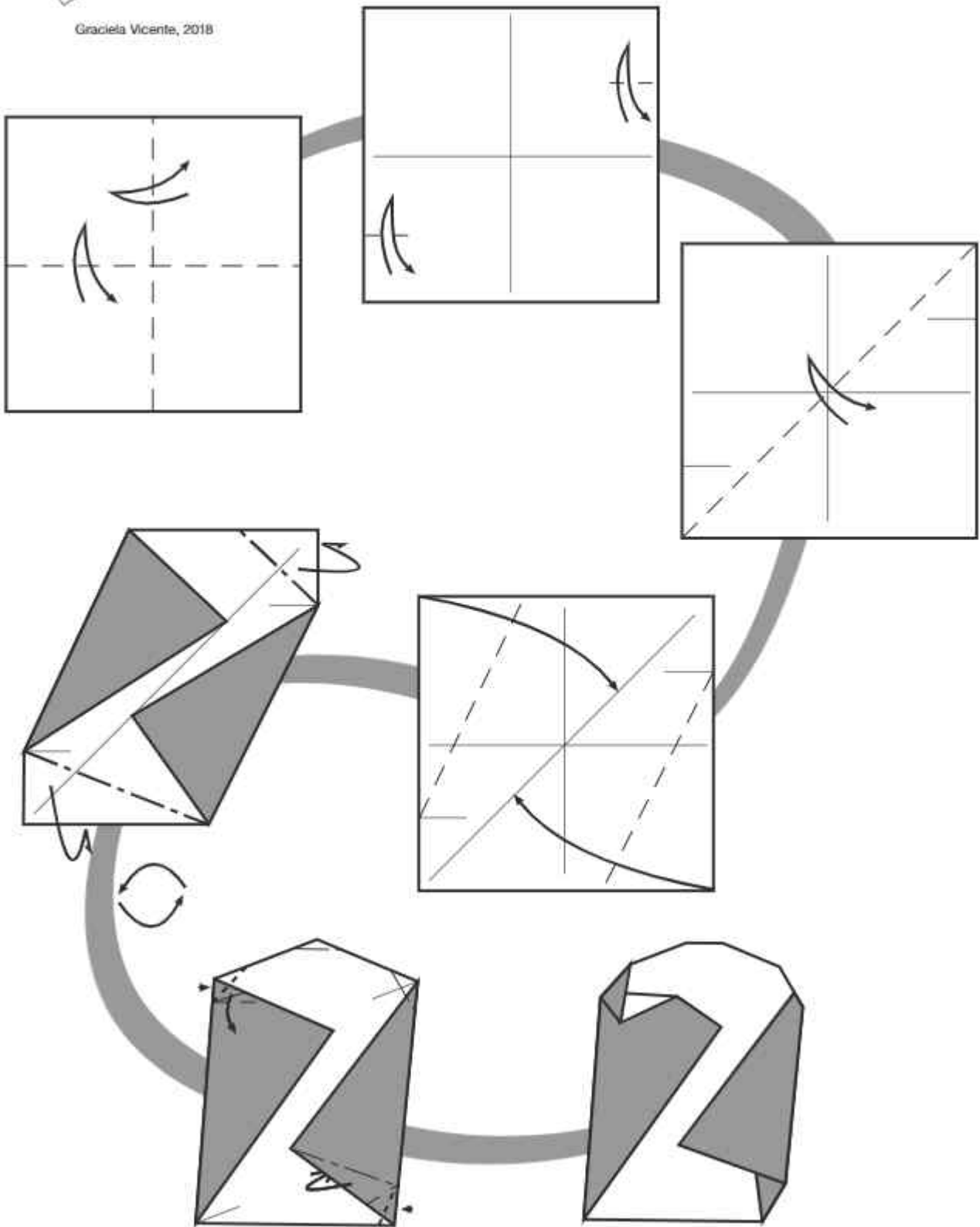



Graciela Vicente, 2018

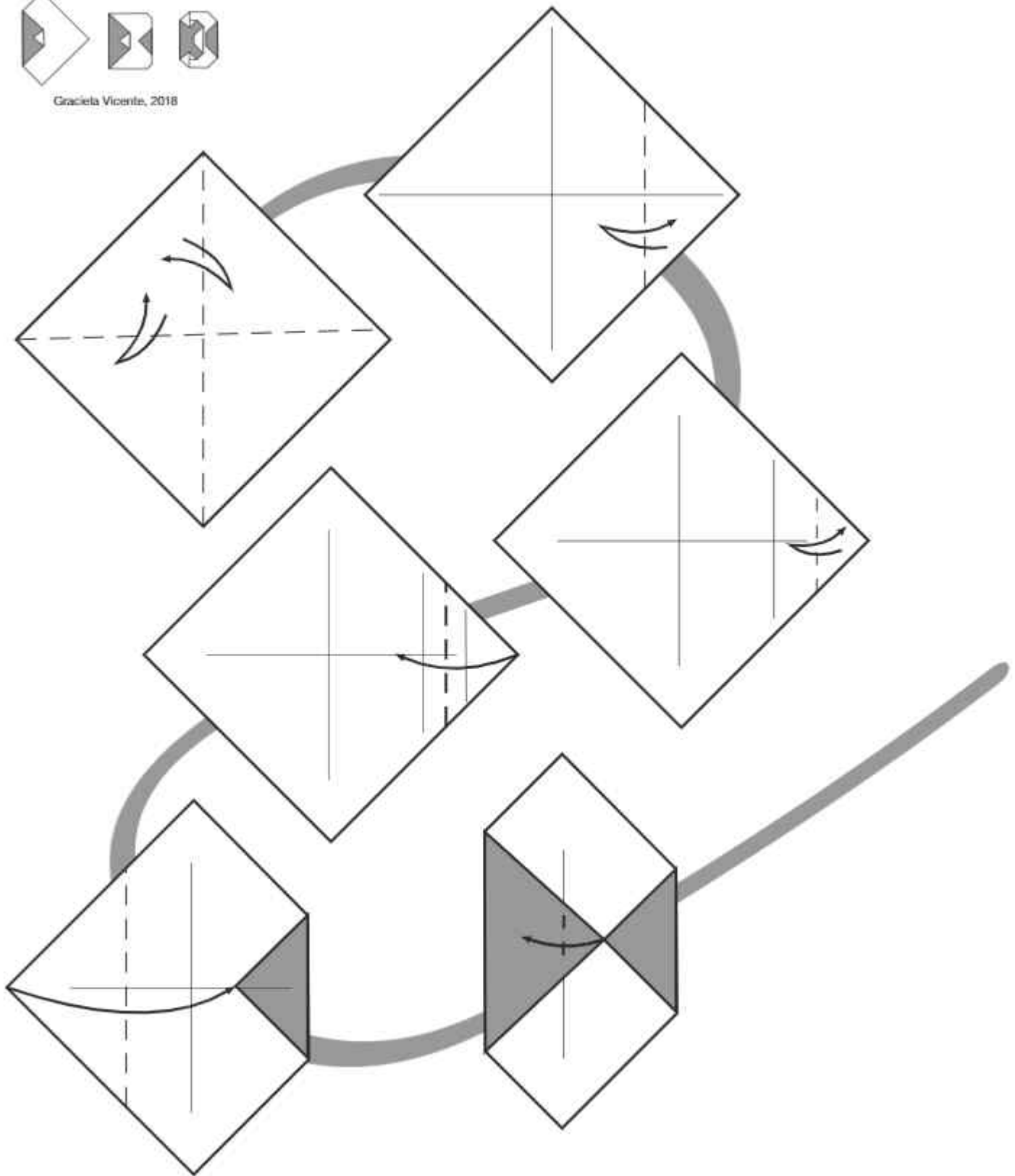

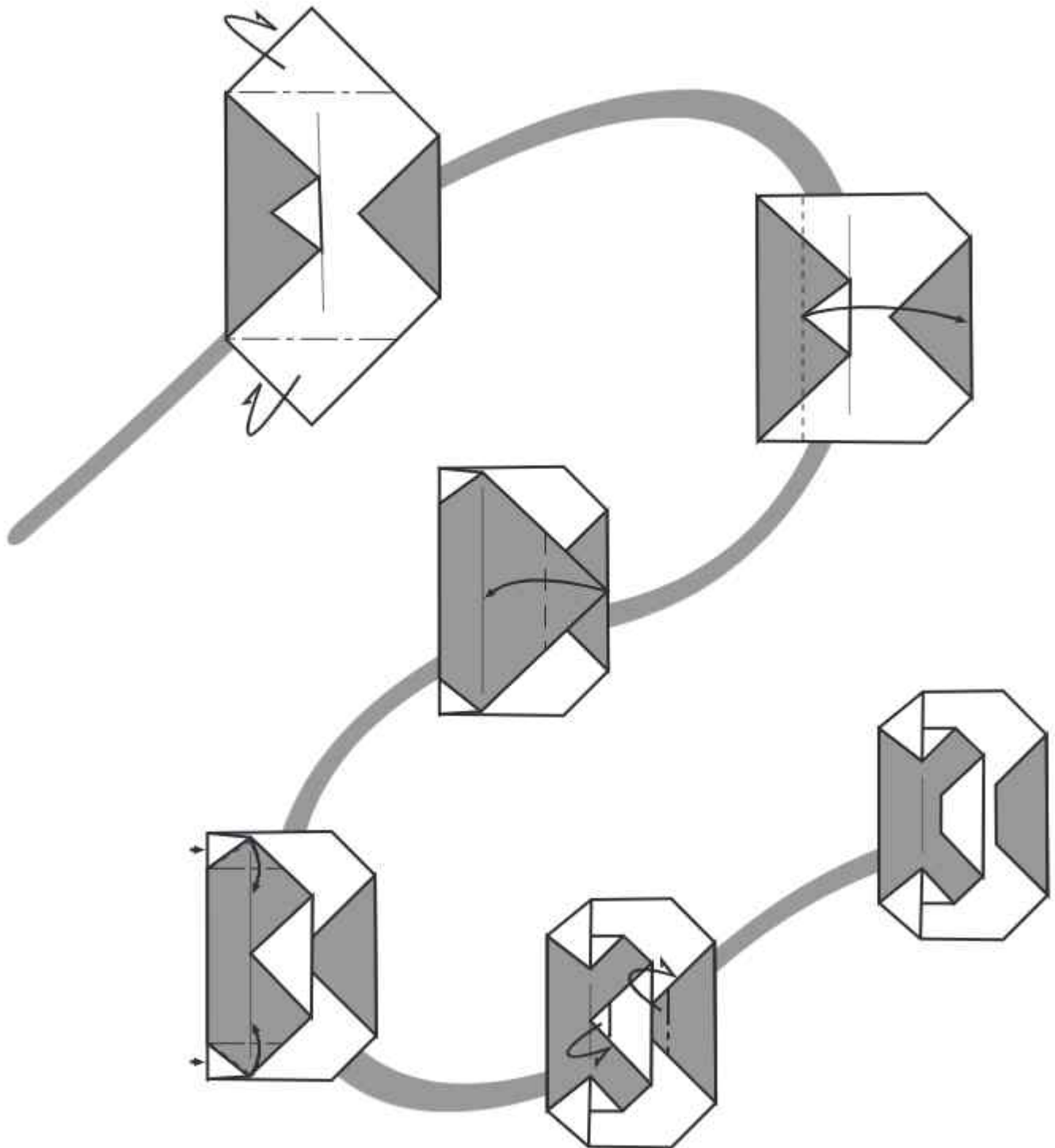

Estrella Buenos Aires / Miguel A. Gañán

Papel recomendado: 15x15 cm o menor, mocolor o bicolor

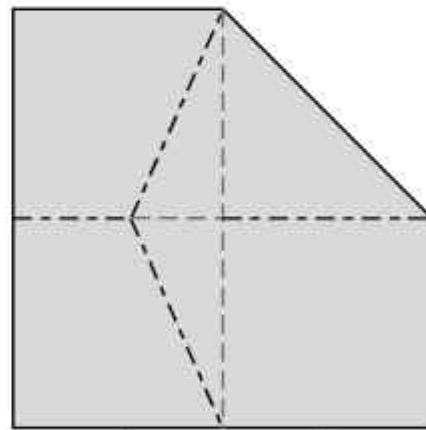
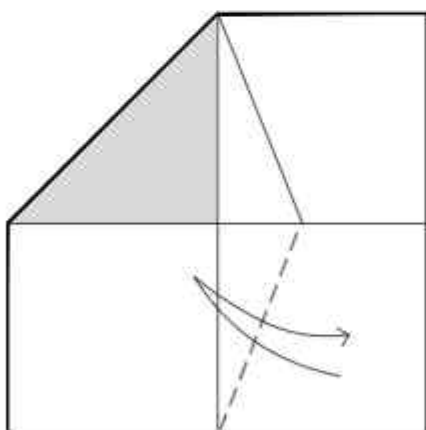
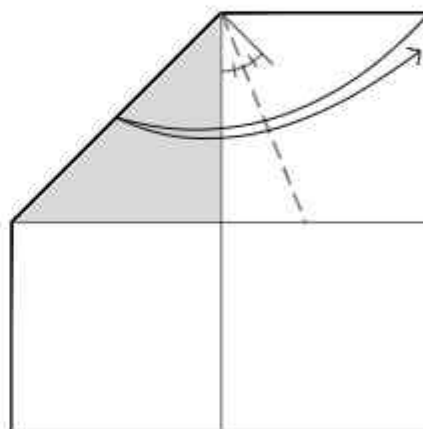
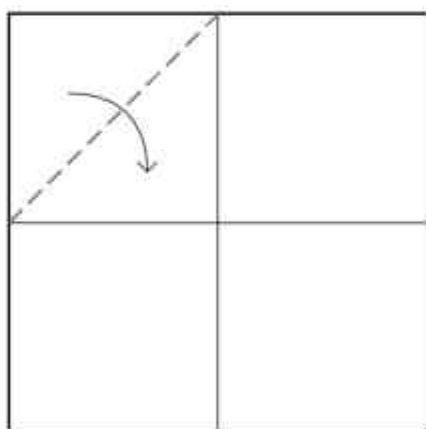
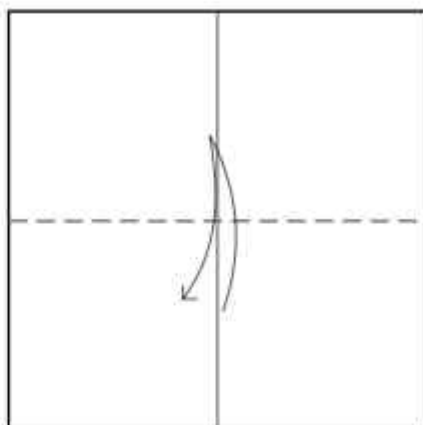
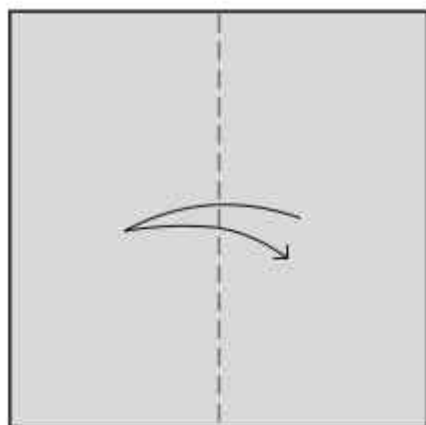

colapsar según montañas y valles

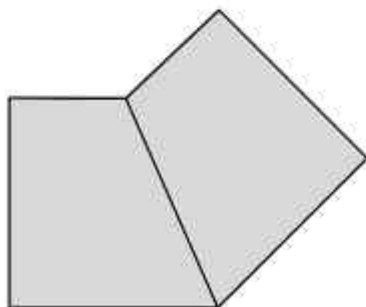

anverso

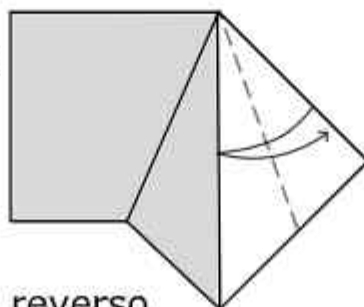

reverso

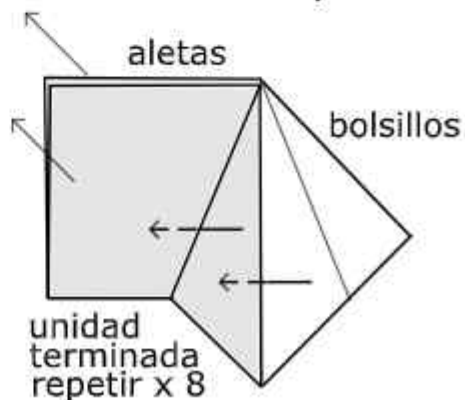

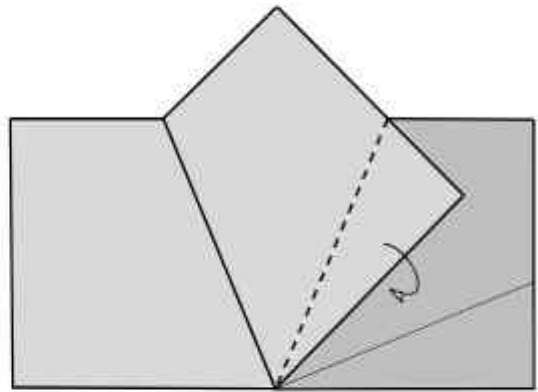
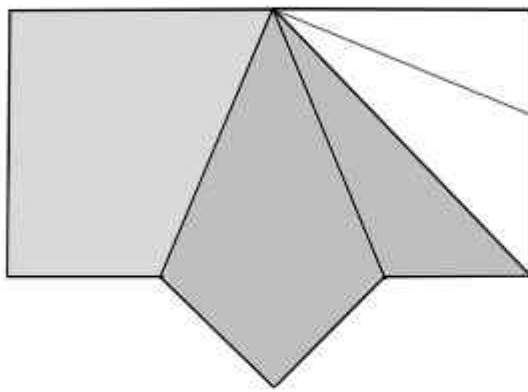
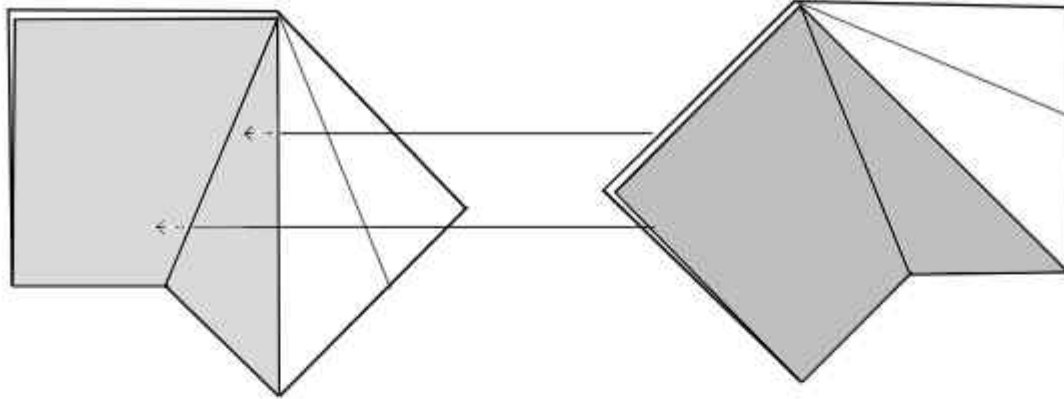

plegar en montaña
introducir en bolsillo del
módulo 2 para trabar

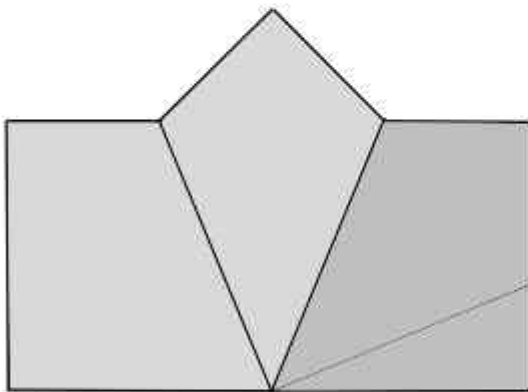

repetir con
los otros módulos



Diagrama:
Miguel A. Gañán



Estrella Zule / Guadalupe Martínez Arellano

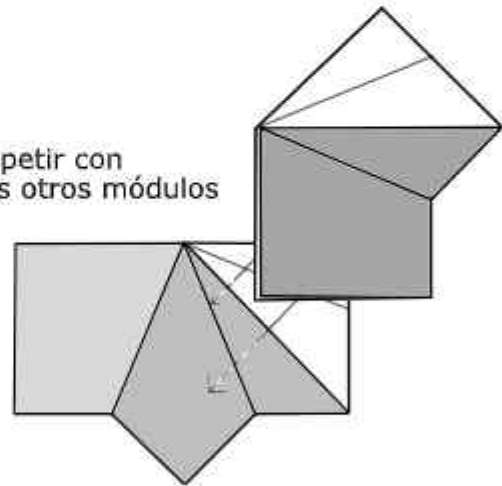
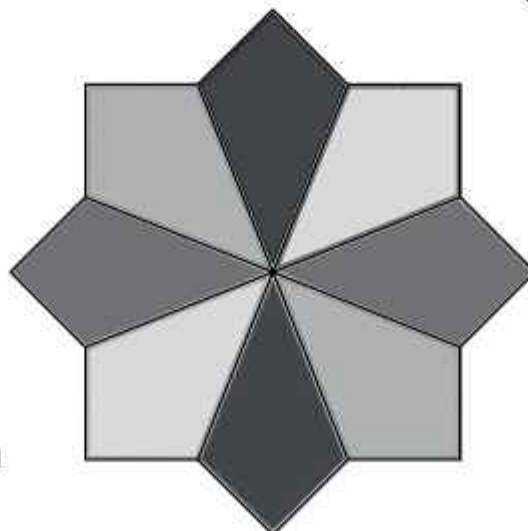

10 hojas doblefaz
7.5 x 7.5cm

Diagrama
Guadalupe Martínez Arellano

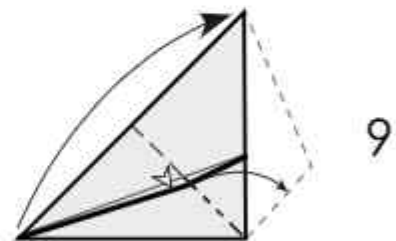
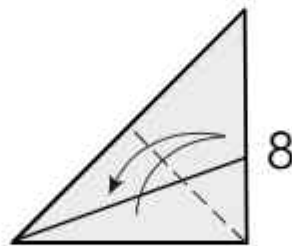
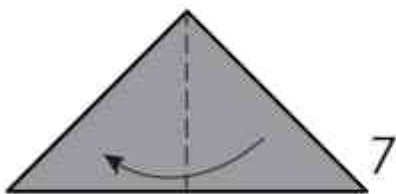
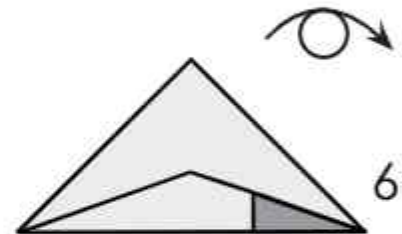
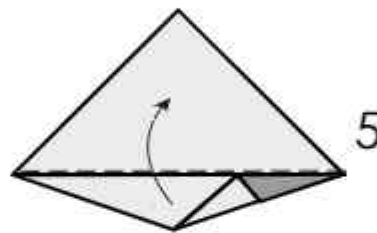
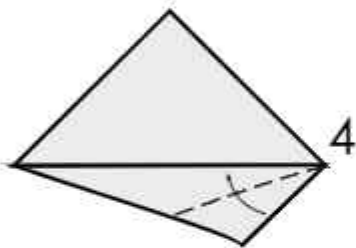
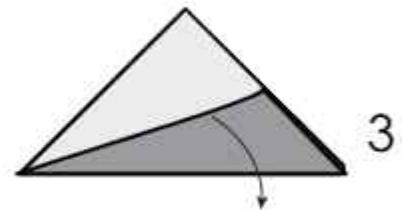
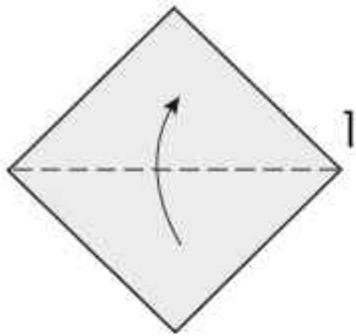

Módulo terminado:

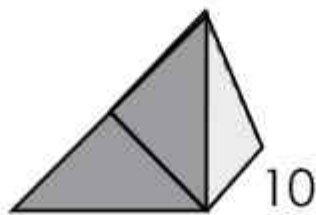

Frente

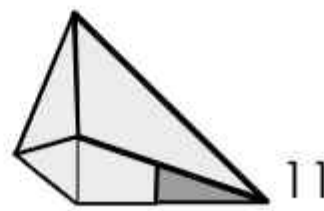

Atrás

Ensamble:

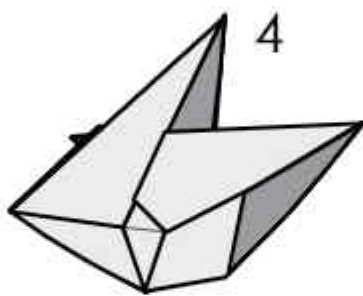
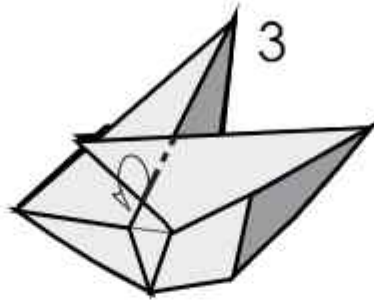
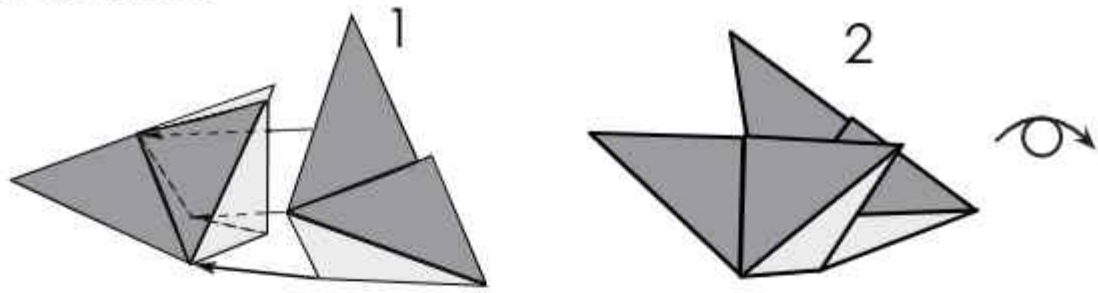

Atrás

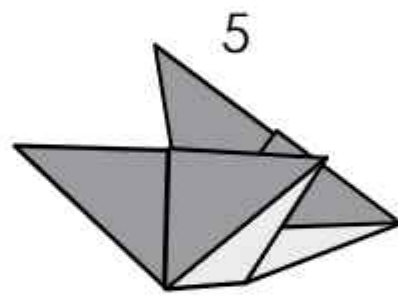

Frente

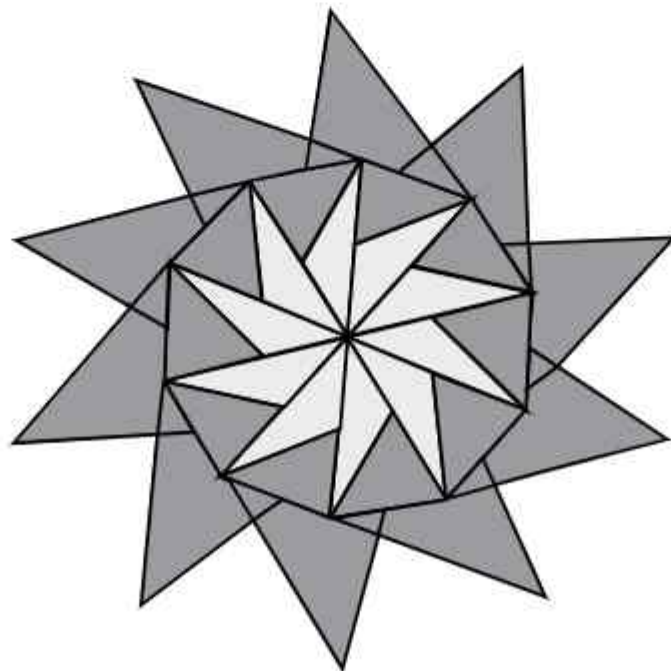

Modelo terminado

Golla Star / Madhura Gupta

Designed and Diagrammed
by Madhura Gupta | India
(August 2021)
[instagram.com/tinnifolds](https://www.instagram.com/tinnifolds)

8 triangular units
No glue
Difficulty: Easy

Preparing the paper:

Fold the two diagonals of the paper.
Cut along them to obtain four
right angled isosceles triangles.



15 cm

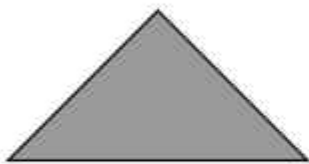

1. Start with the
color side up.

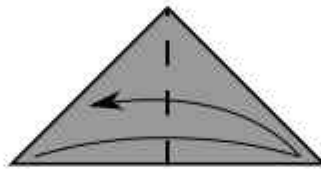

2. Fold in half
and unfold.



3. Bring the raw
edge to the centre;
make a valley fold.

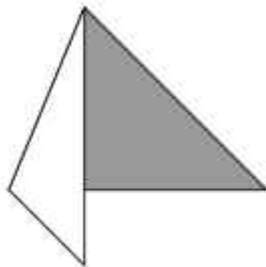

4. Flip the model
horizontally.

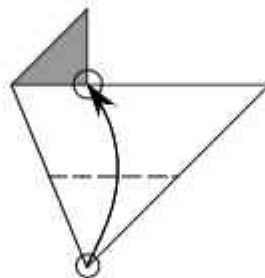

5. Fold the lower corner
such that the two points
coincide.

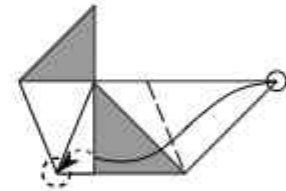

6. Bring the upper right
corner to the lower left;
tuck the paper inside
the triangular flap.

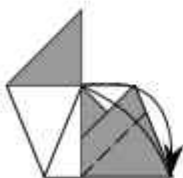

7. Fold the lower right
corner along the
central crease; unfold.

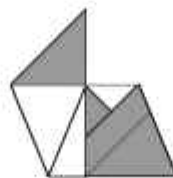

8. The completed
unit.
Make 7 more.



The reverse of
the unit.

Assembly

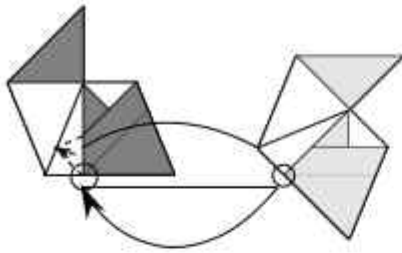

1. Take two units.
Slide such that the two
points coincide.
Note that the corner
of the second unit
goes inside the flap of
first unit.



2. This is how it
should look.
Turn over.

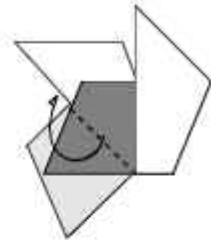

3. Mountain fold the
flap behind the
other unit.

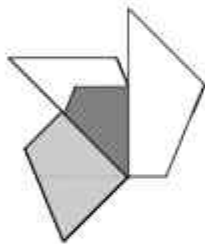

4. This is how it
should look.
Turn over.



5. Continue adding the
remaining 6 units in
a similar way.

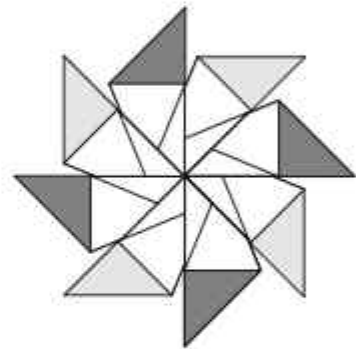

6. This is how it should
look. Turn over.

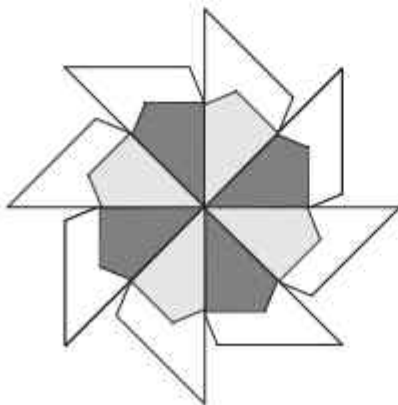

The completed **Golla Star**

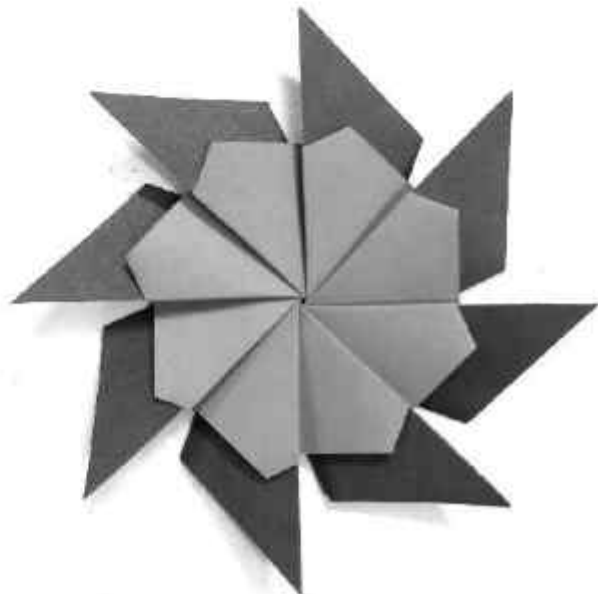

Gunda Star / Madhura Gupta

Designed and Diagrammed
by Madhura Gupta | India
(March 2022)
[instagram.com/tinnifolds](https://www.instagram.com/tinnifolds)

8 triangular units
No glue
Difficulty: Easy

Preparing the paper:

Fold the two diagonals of the paper.
Cut along them to obtain four
right angled isosceles triangles.



15 cm

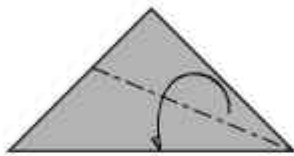

1. Start with color side up.
Bring the upper right edge
along the lower edge.
Crease.



2. Bring the lower edge
and align with the central
crease.

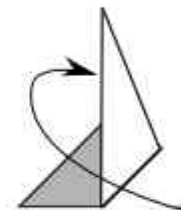

3. Unfold to step 1.

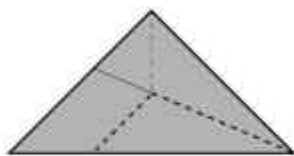

4. Change the three
creases to mountain
as indicated.

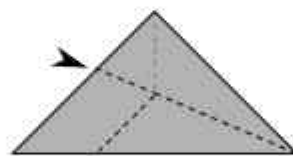

5. Push from the
left to collapse the
model.

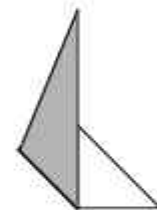

6. This is how it
should look.
Turn over.

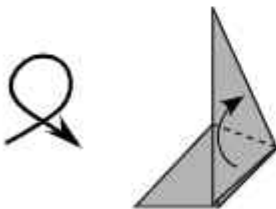

7. Unfold the flap,
making a valley
fold.

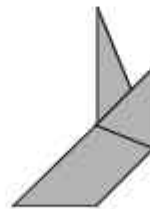

8. The complete unit.
Make 7 more.

Assembly

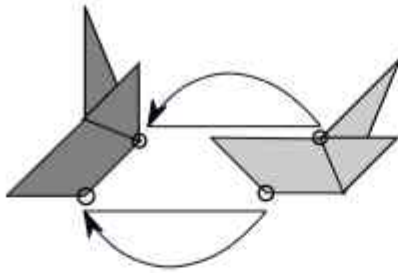

1. Take two units.
Slide such that the
points coincide.

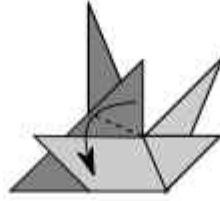

2. Bring the flap
down.

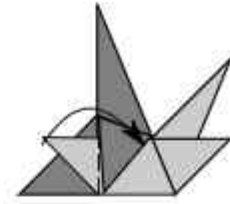

3. Bring the flap
to the right.

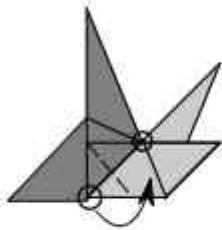

4. Bring the lower
corner to the top,
as indicated by the
points.

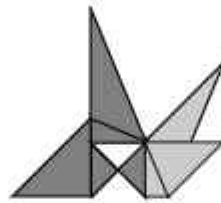

5. Two units joined,
Rotate to the left.

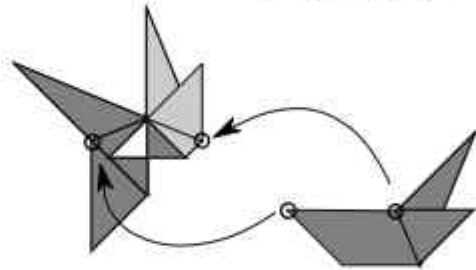

6. Add the third unit
such that the points
coincide.
Note the reference
points.

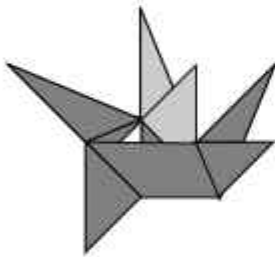

7. Repeat steps 2 - 5
Continue adding the
remaining 5 units in
this way.

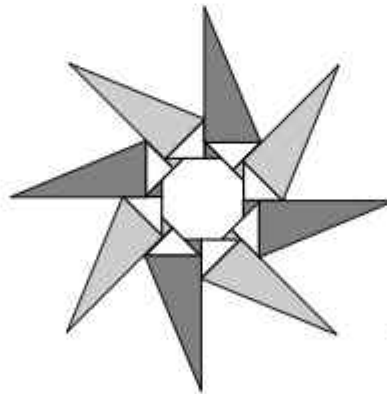

8. This is how it
should look.
turn over.

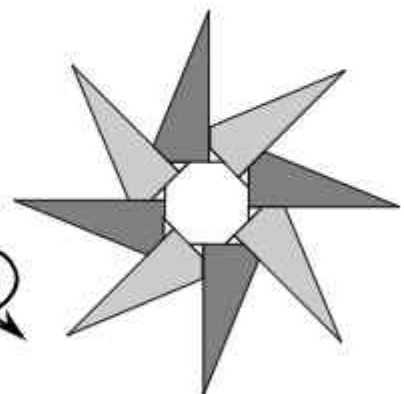

The completed
Gunda Star

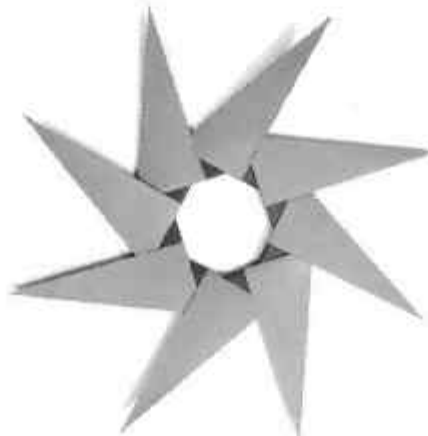

Filhote de Cachorro / Keila Correa de Paula

FILHOTE DE CACHORRO
POR KEILA CORRÊA DE PAULA

DIAGRAMAS: PEDRO ADARICIO

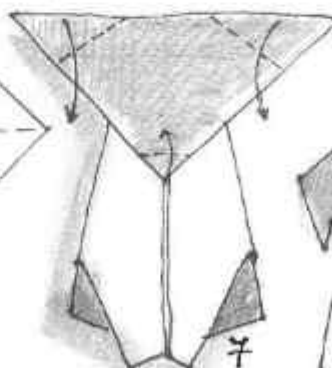
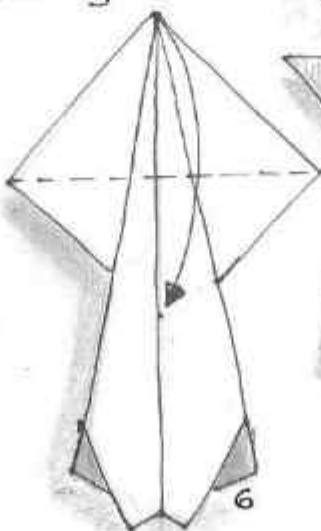
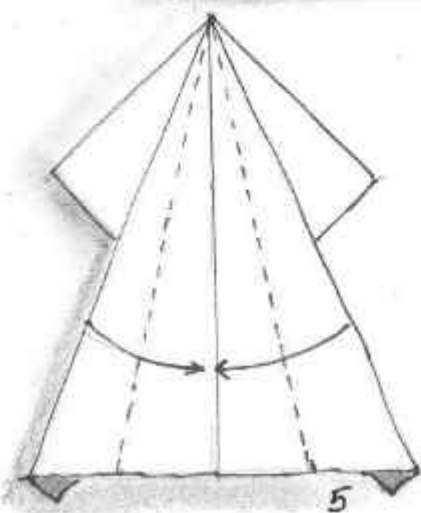
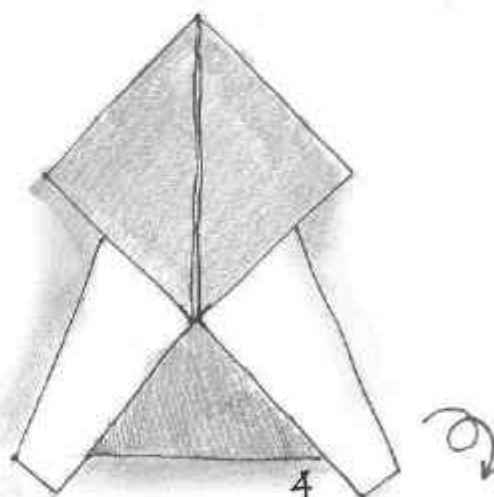
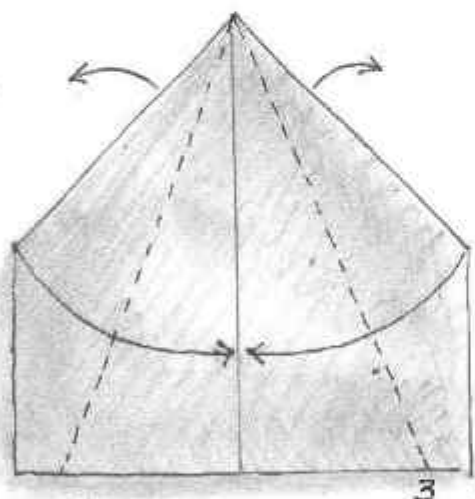
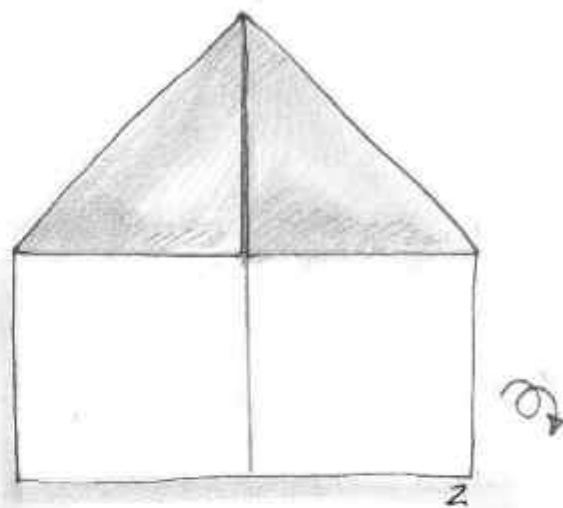
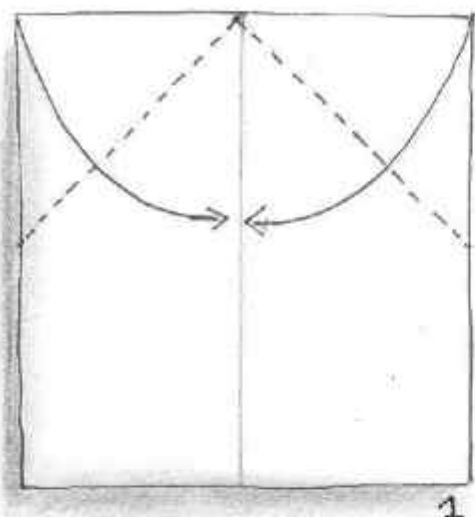

Mandala "Guionna"

Diseñada por: Leticia Cruz Santos

1

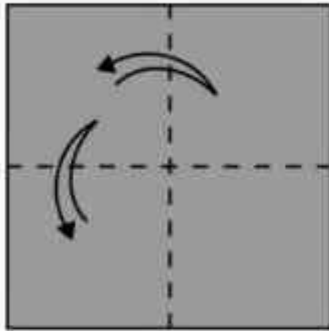

2

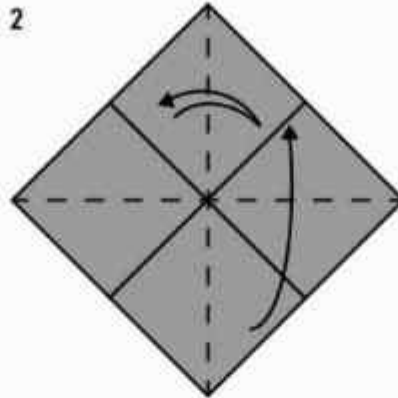

3

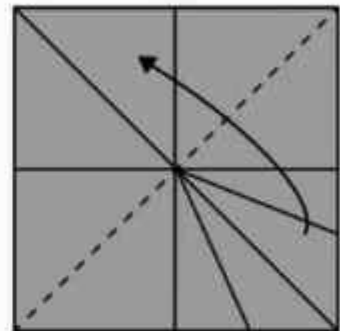

4

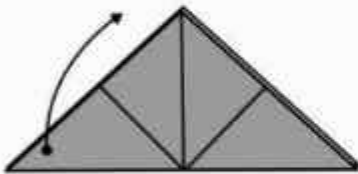

5

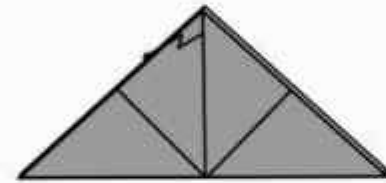

6

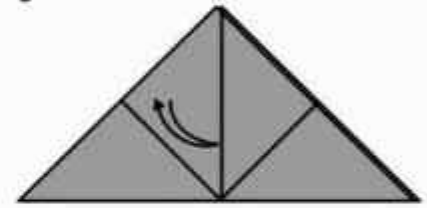

7

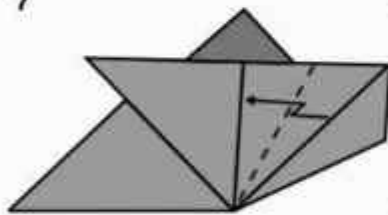

8

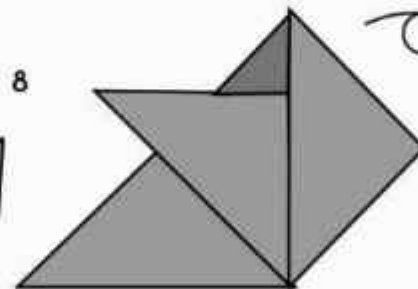

9

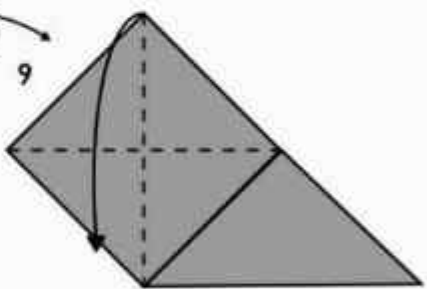

10

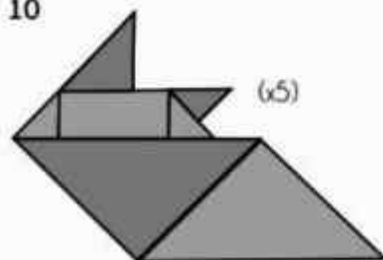

11

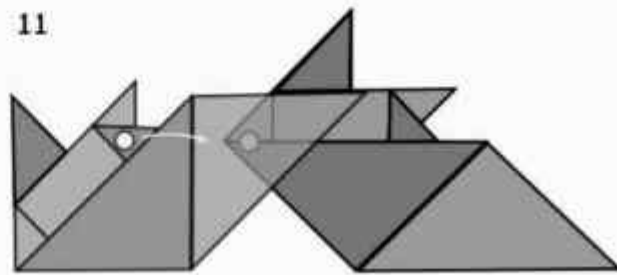

11

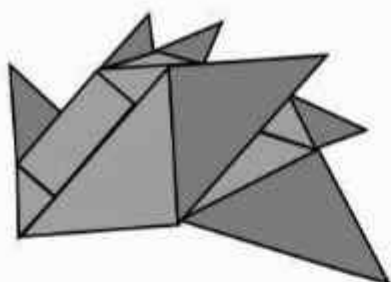

12

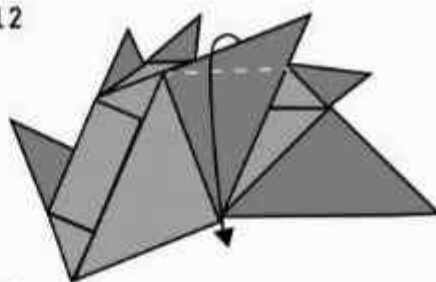

13

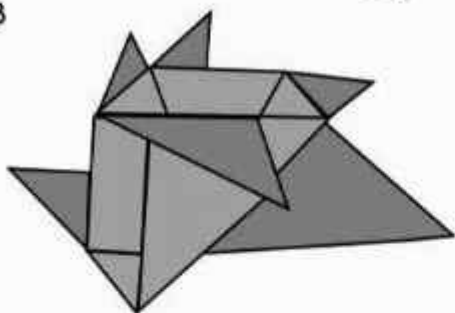

14

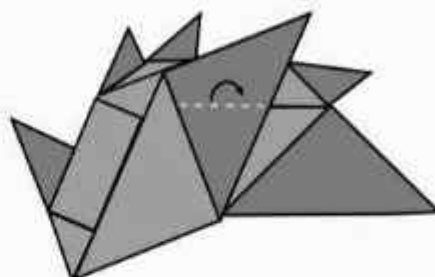

15

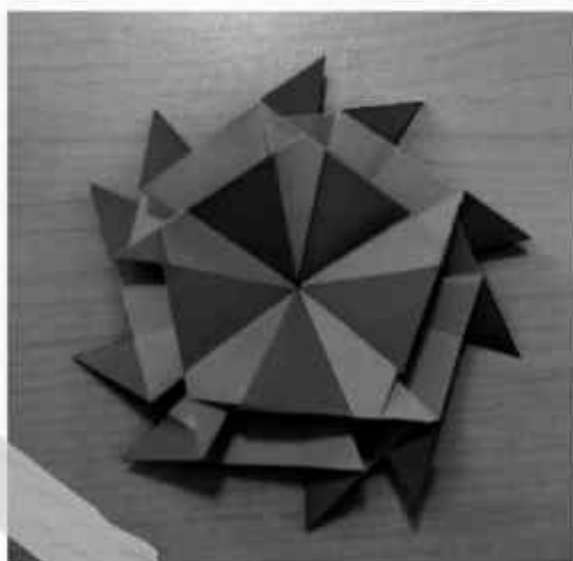
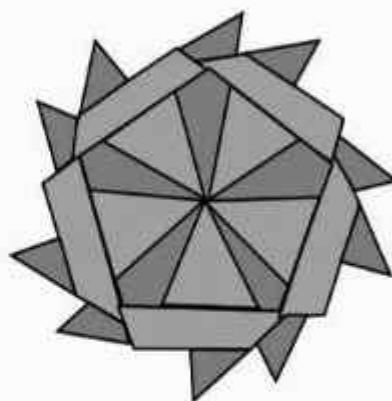
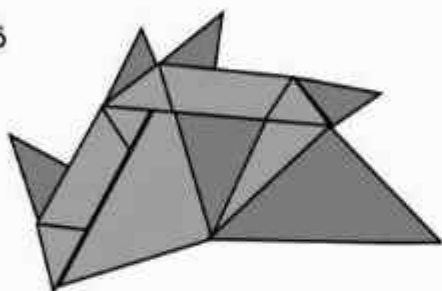

Diagramada por: Nayomi Yosahandy Gasca Cruz

Pañuelo Blanco / Lidia Eymann

Pañuelo blanco
de Lidia Eymann
@lidiaeymann
2021

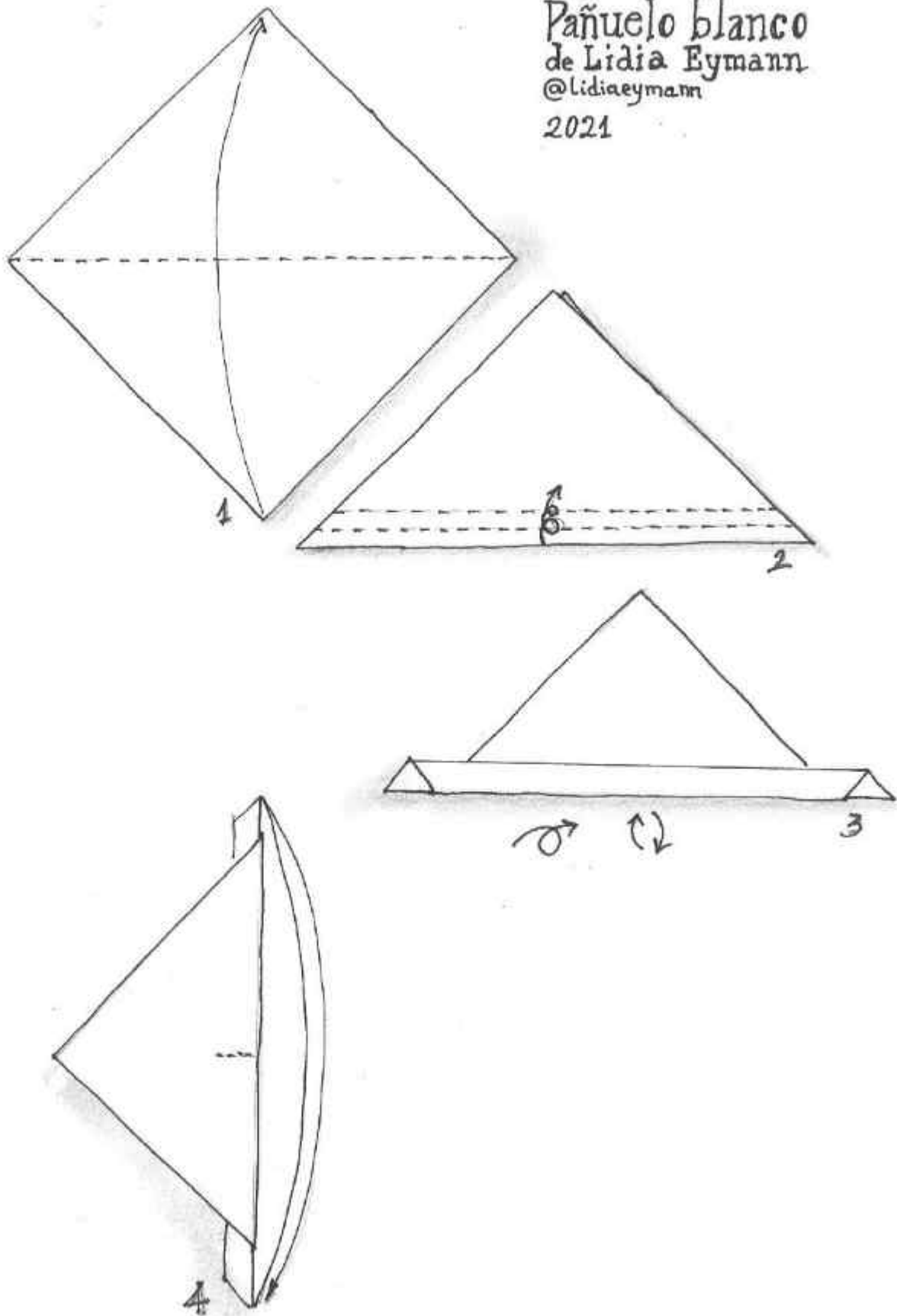

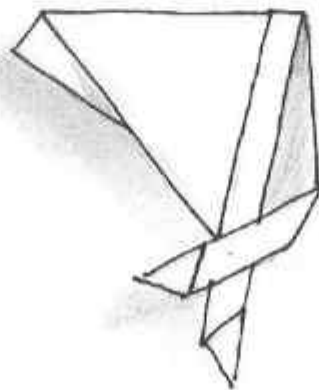
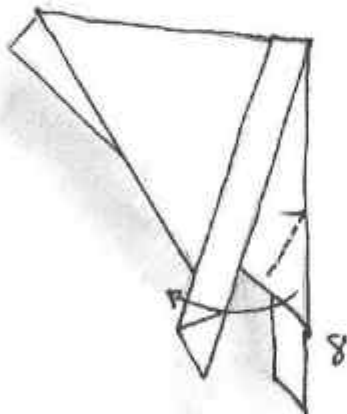
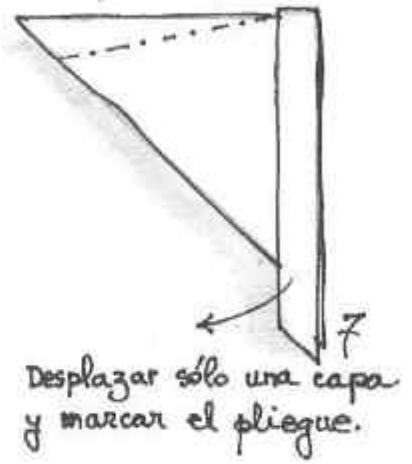
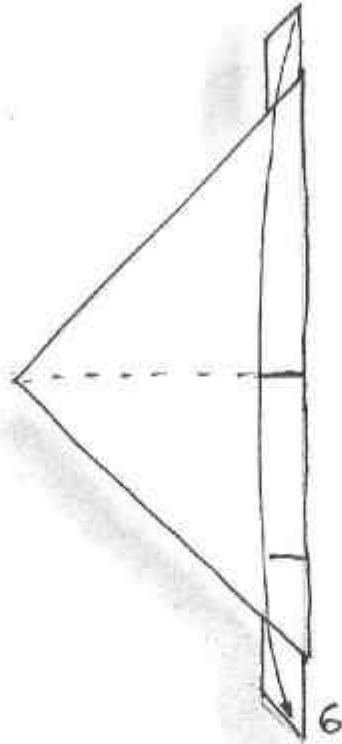
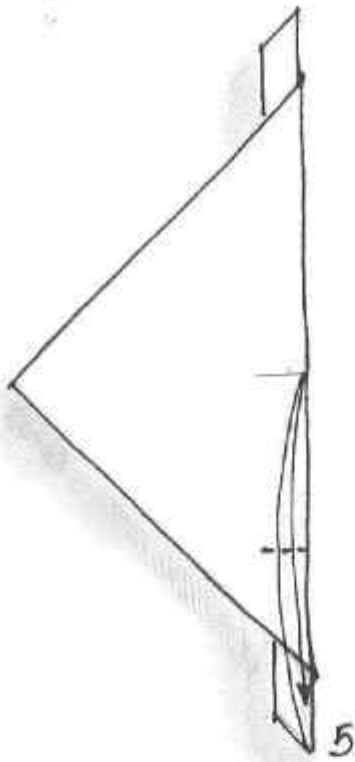

Diagramas, Pedro Aparicio
@tallerdelaribera

Papá Noel / Mimi Nohara

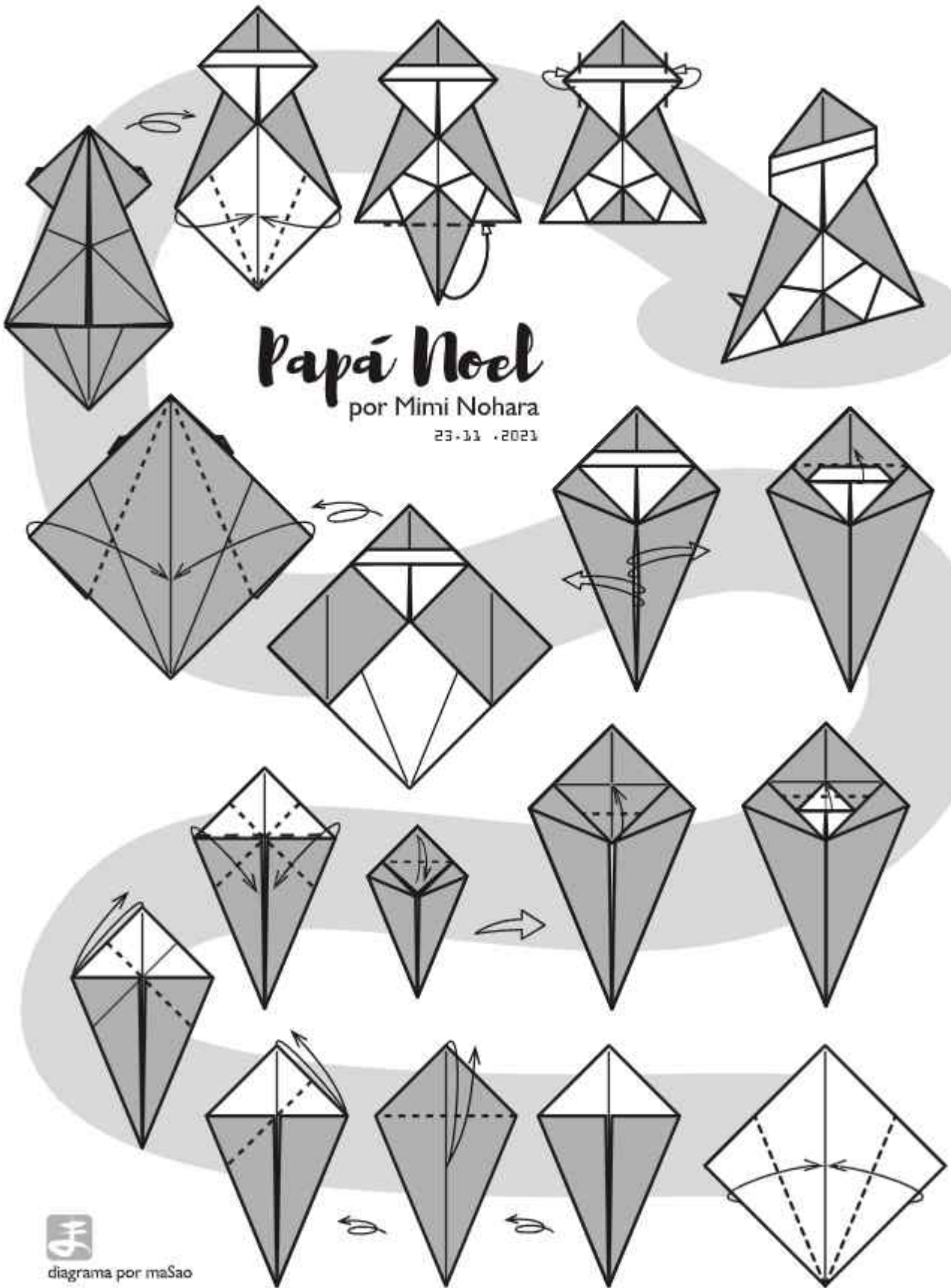

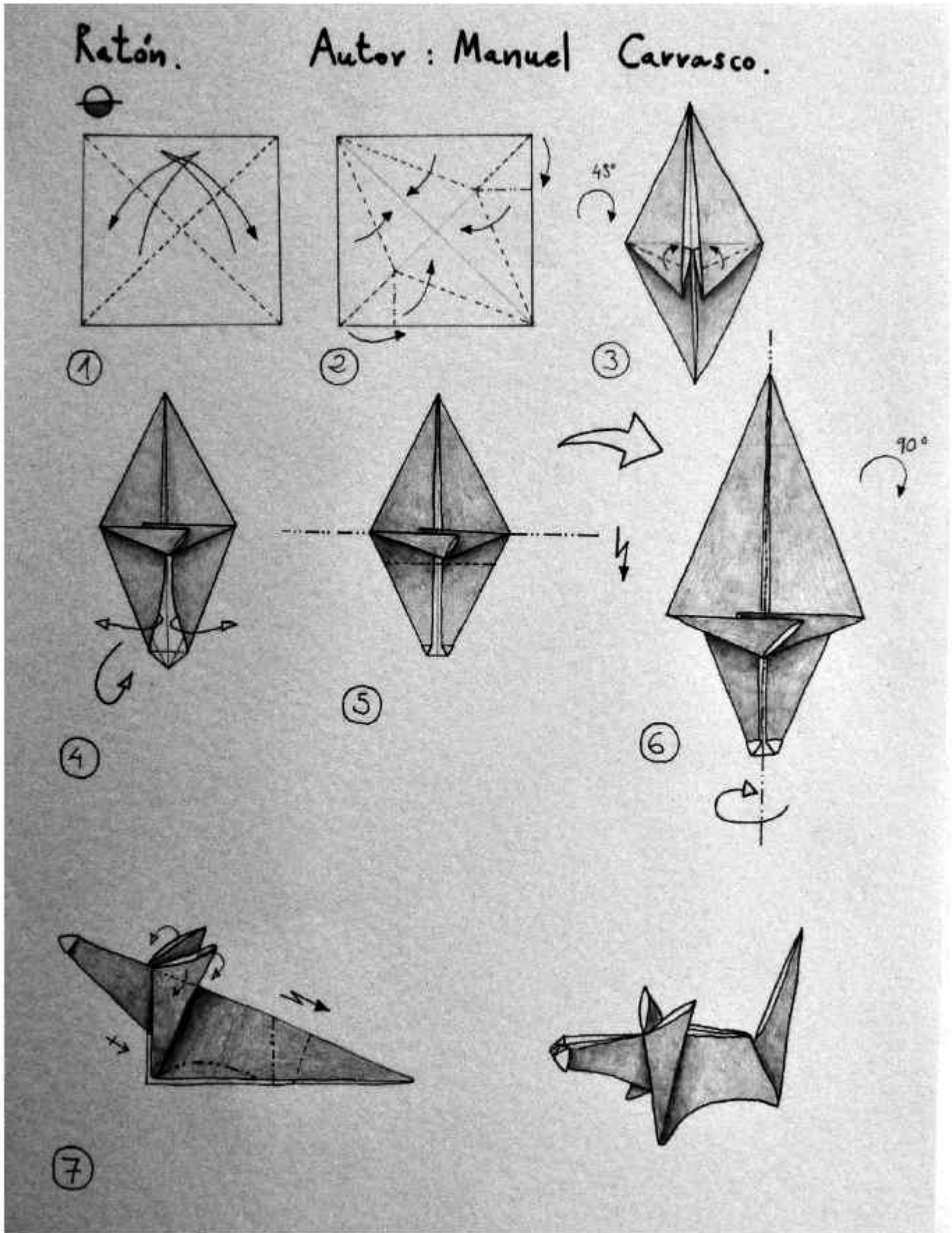

Rompecabezas Sorpresa / David Medina

Diagrammi di Paolo Bascetta

1

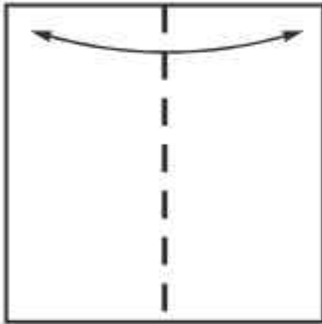

2

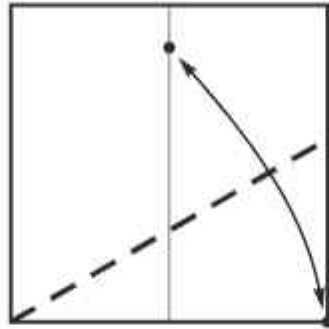

3

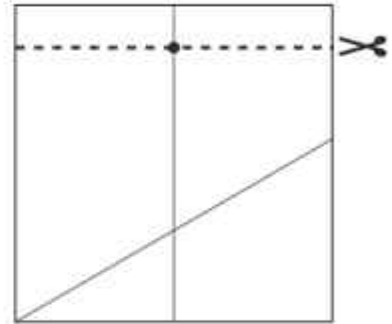

4

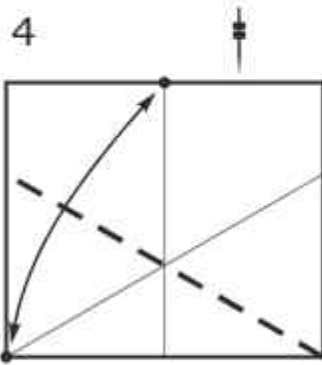

5

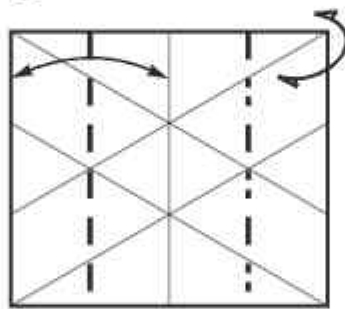

6

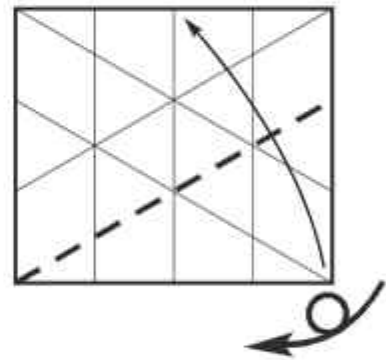

7

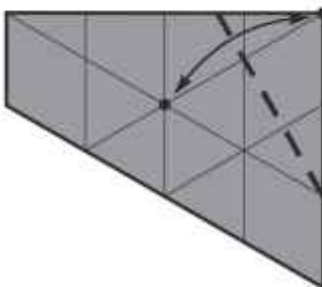

8

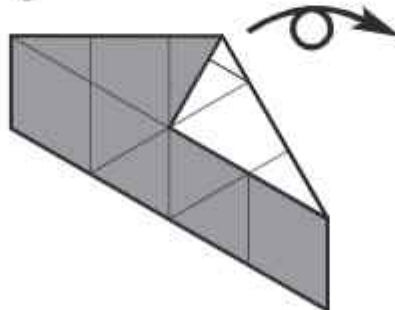

9

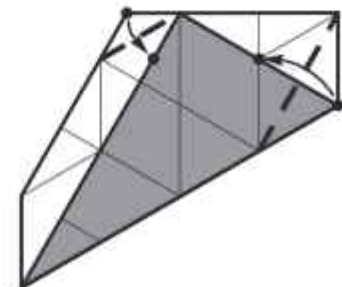

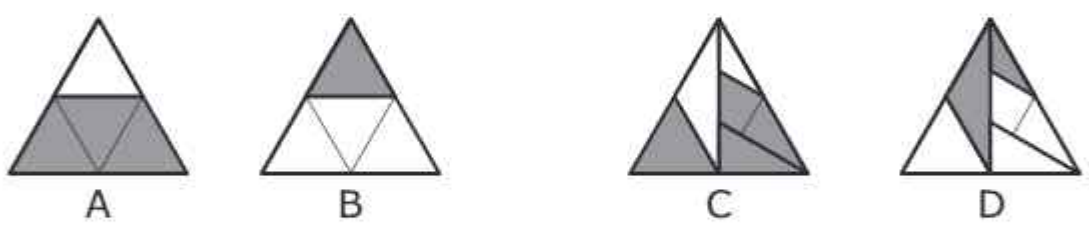
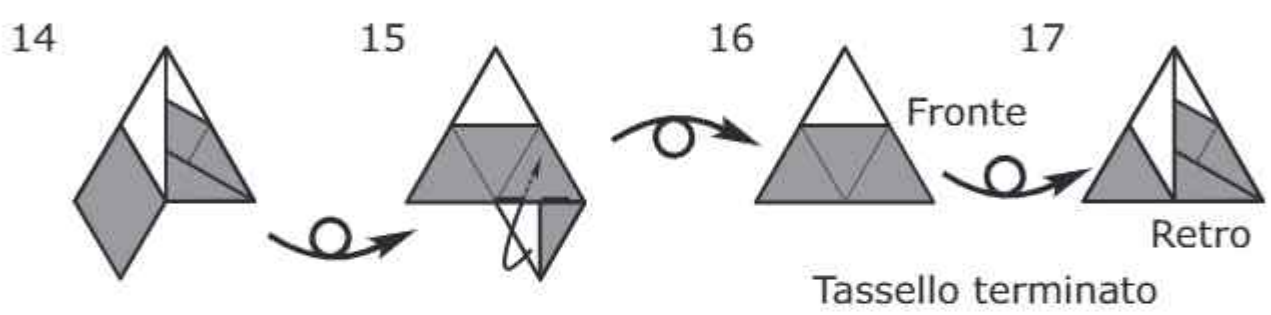
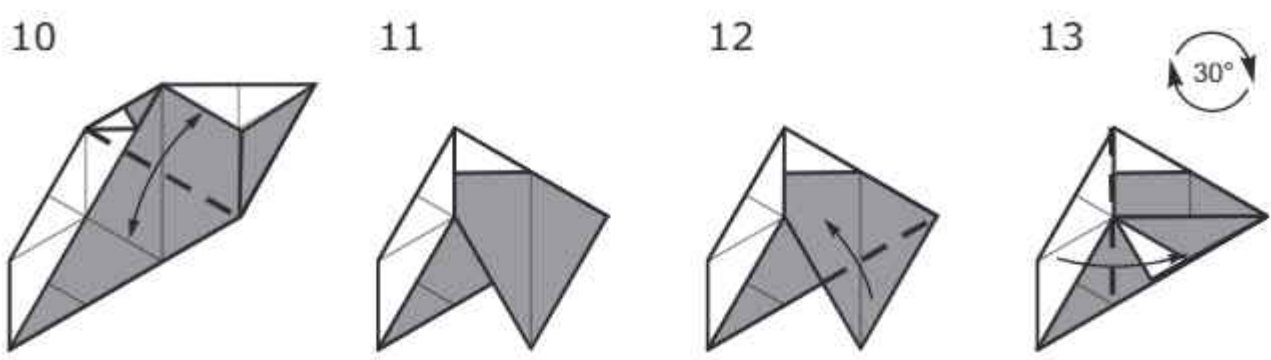

Ci sono queste quattro possibilità

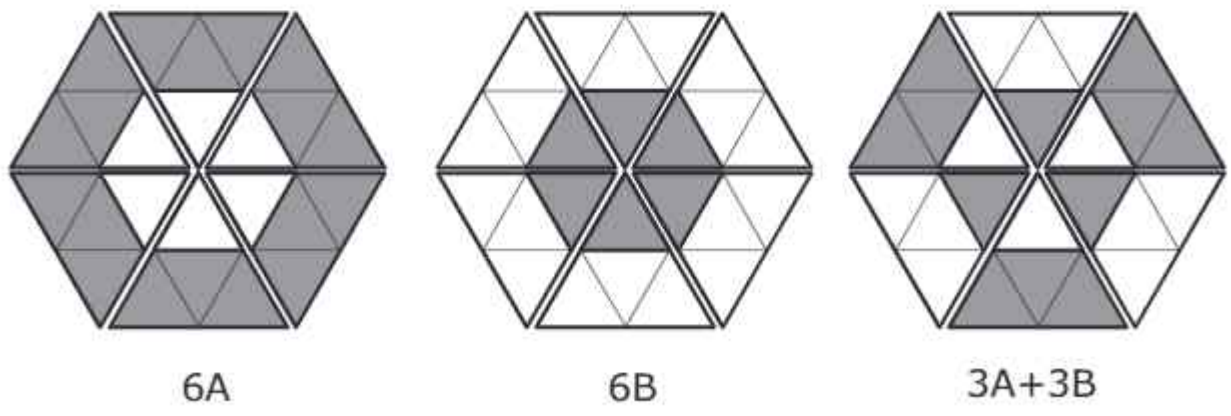

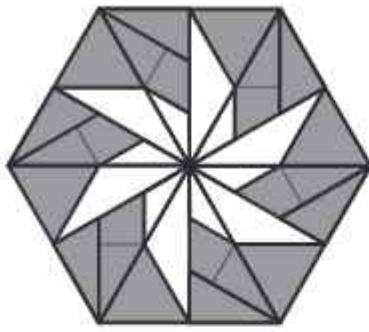

6C

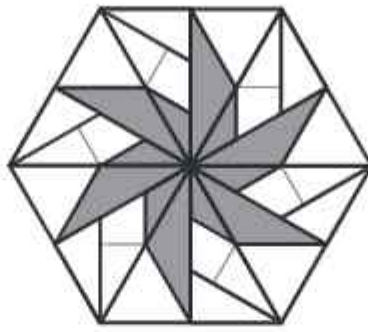

6D

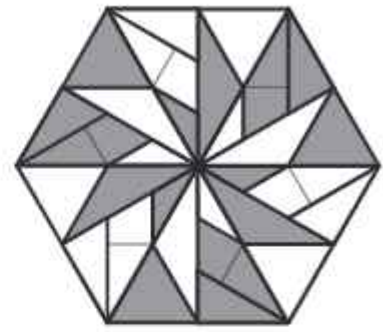

6C+6D

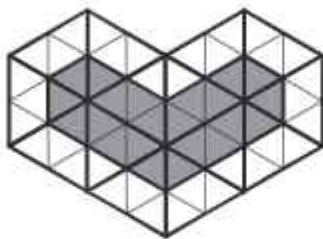

4A+10B

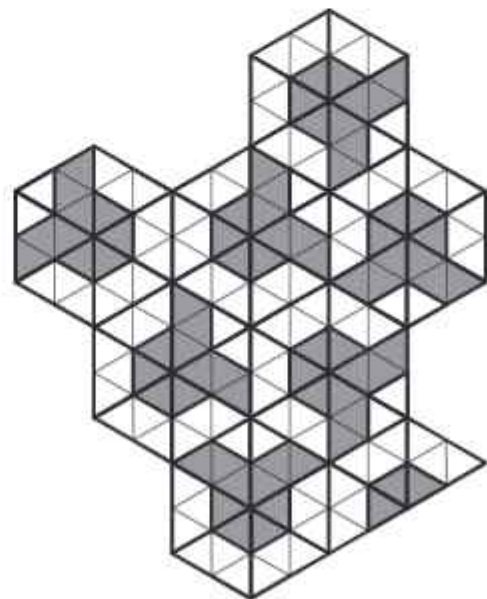
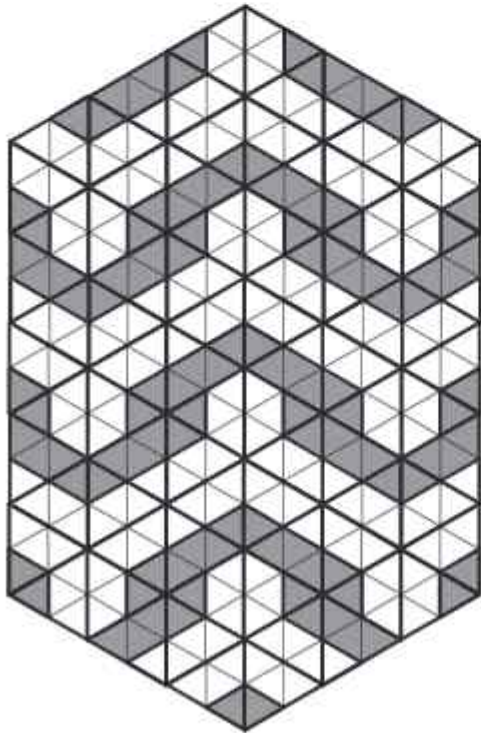
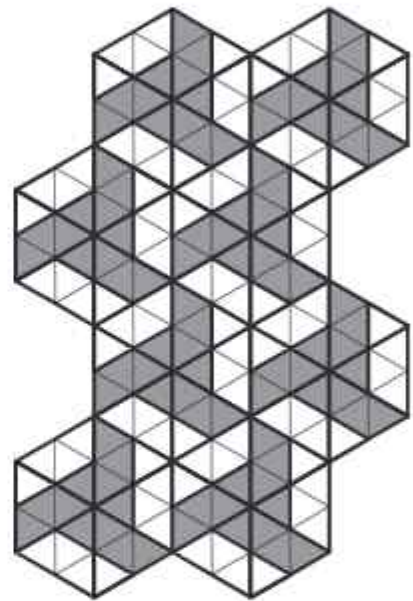
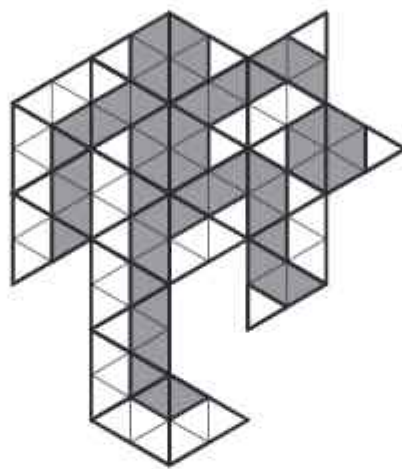

Stella Floreale / Francesco Guarnieri

Diagrammi
Francesco Guarnieri

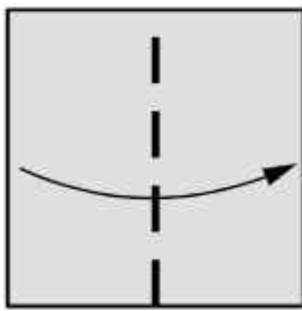

①



②

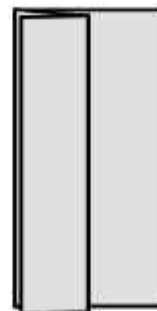

③

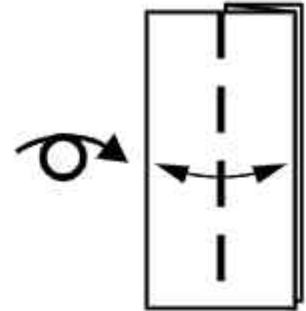

④

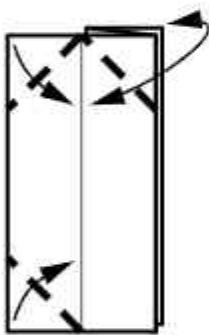

⑤

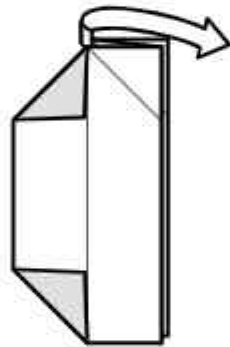

⑥

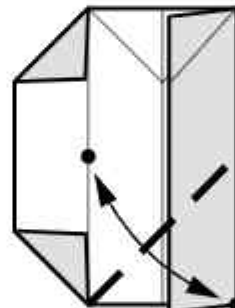

⑦

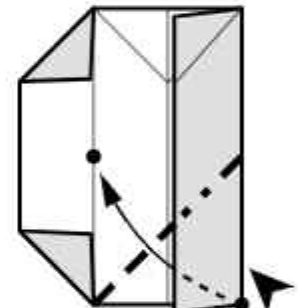

⑧

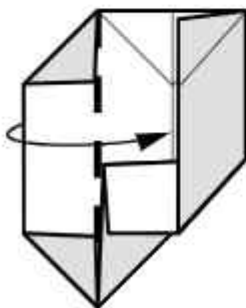

⑨

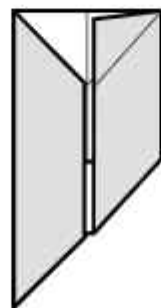

⑩

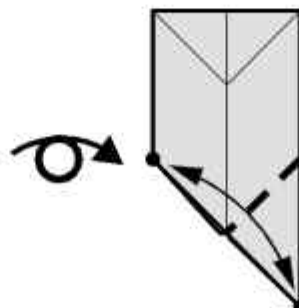

⑪

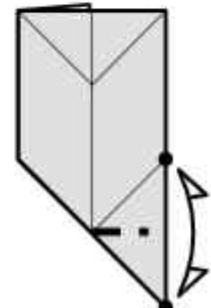

⑫

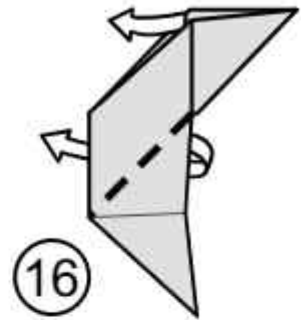
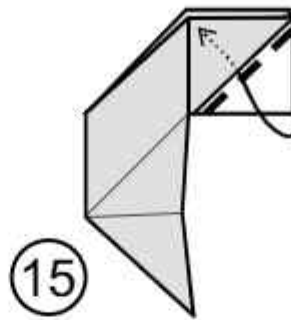
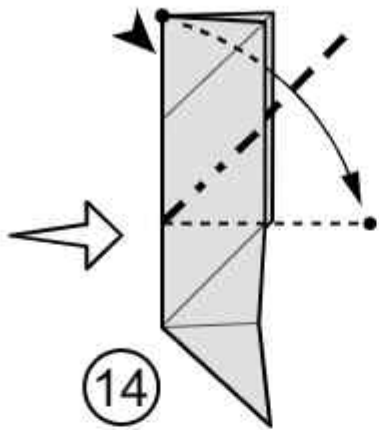
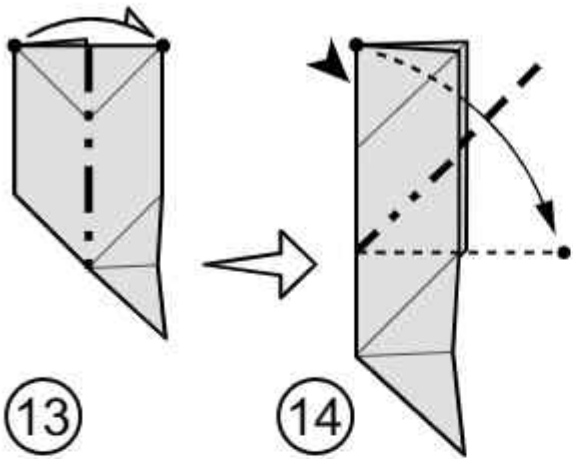

Modulo completo.

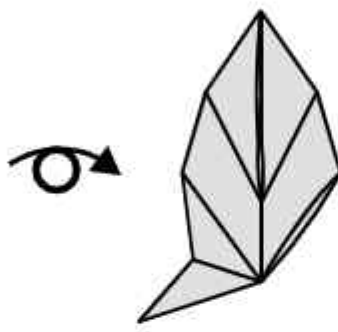

X 5

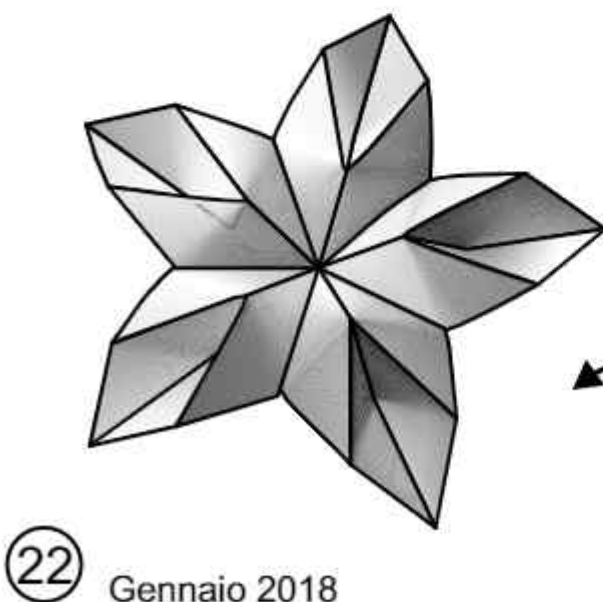
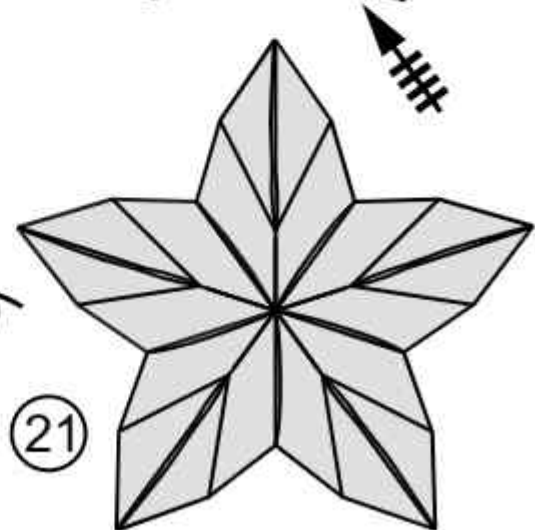
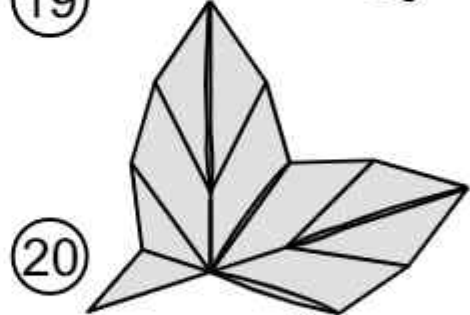
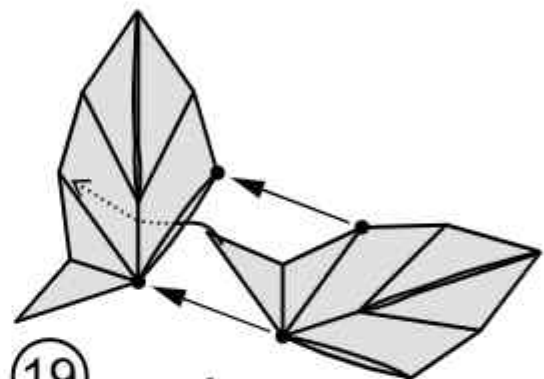

Gennaio 2018

Tappy Star / Patrizia Porzio

diagrammi dell'autrice (luglio 2020)

Colore sopra

1

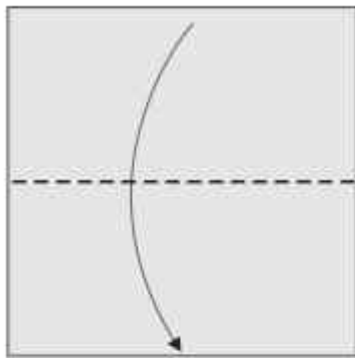

2 Ripetere dietro

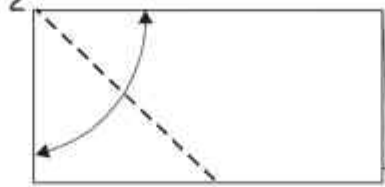

3 Ripetere dietro

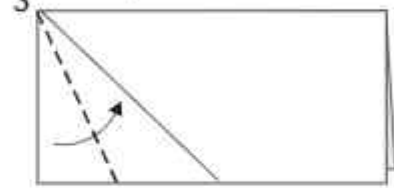

4 Ripetere dietro

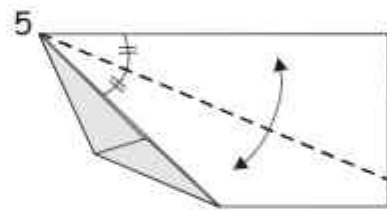
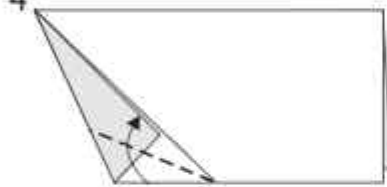

6 Ripetere dietro

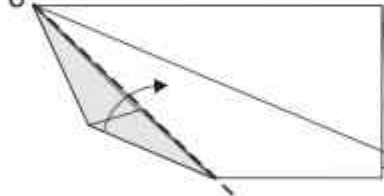

Rialzare il lembo

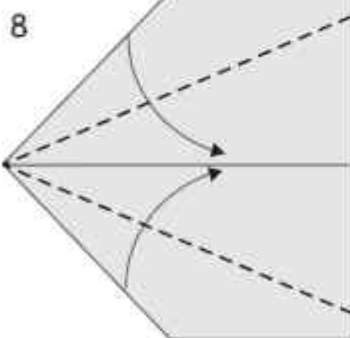
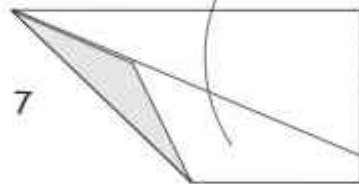

9

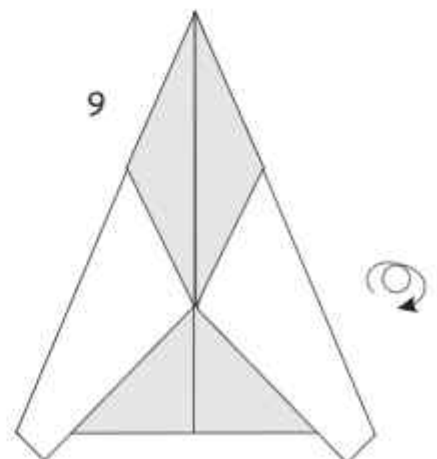

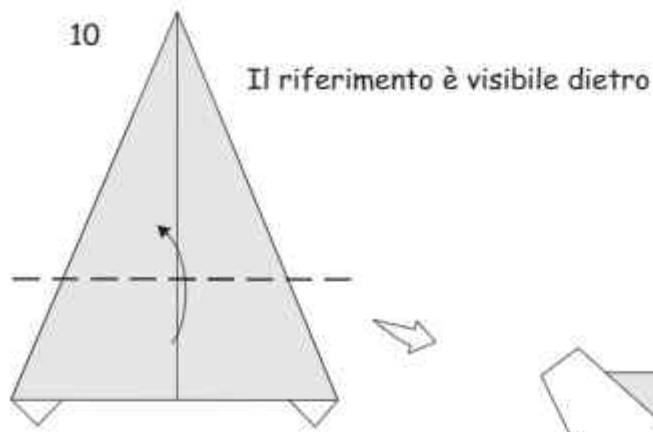

Modulo ultimato x 7

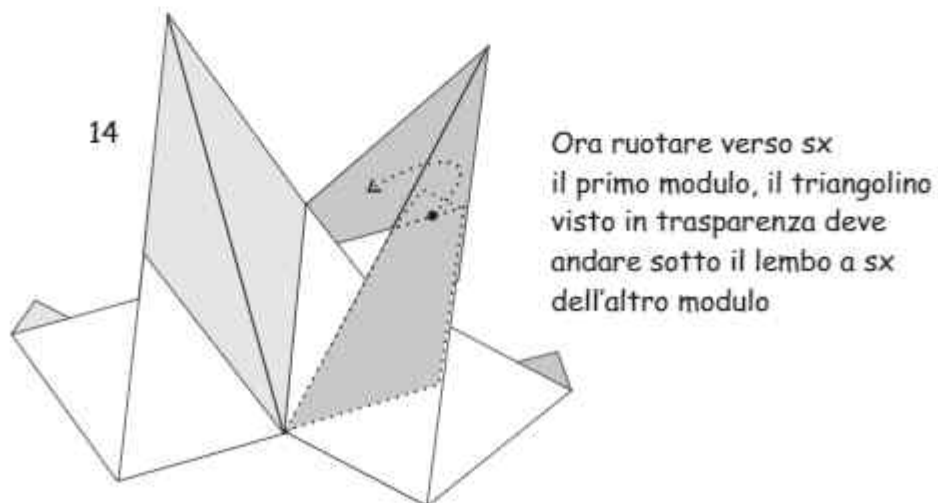
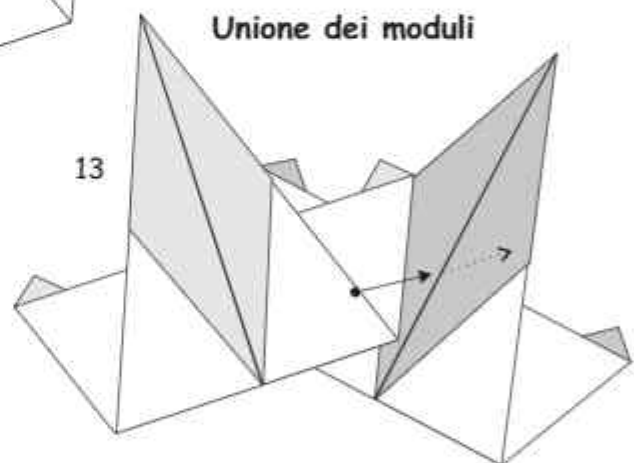
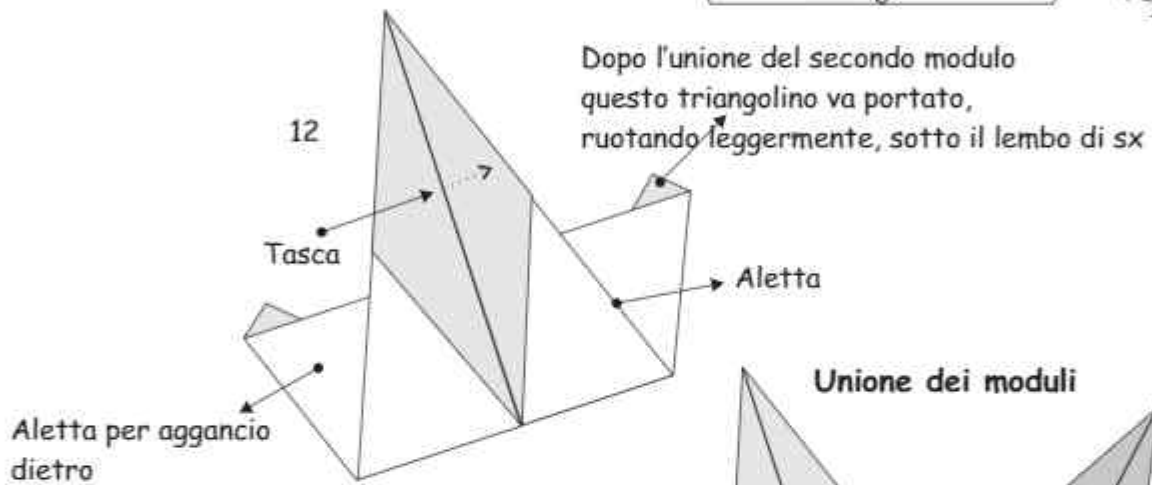
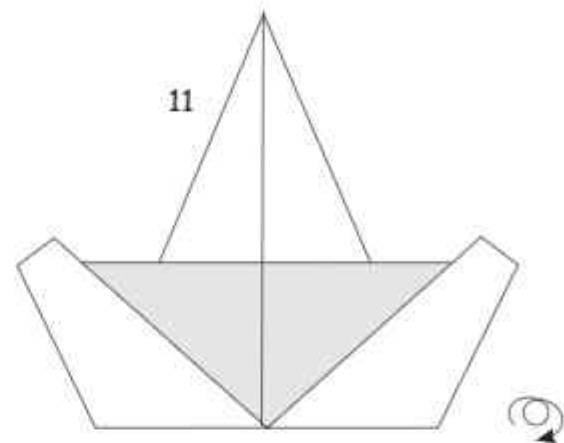

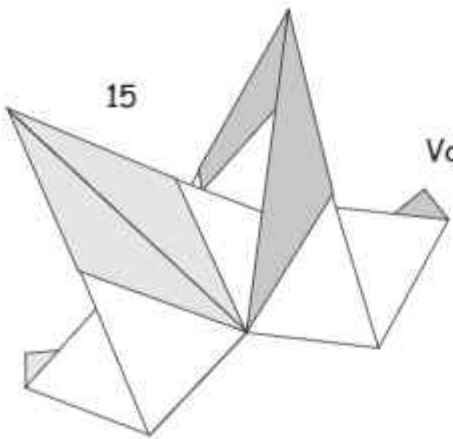

Voltare e chiudere l'aletta di aggancio

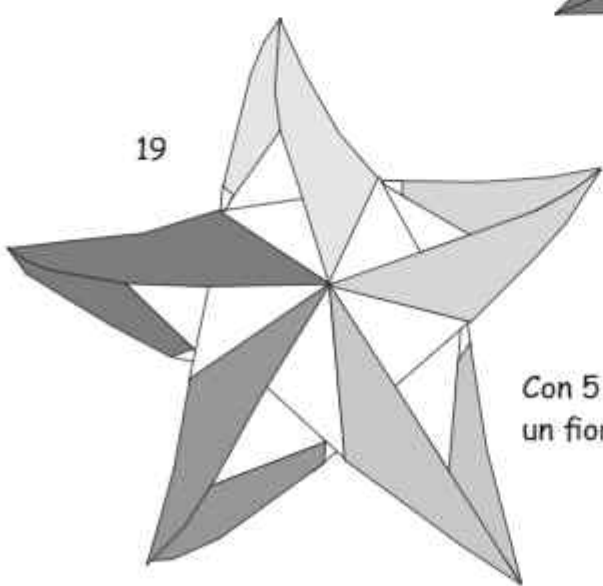
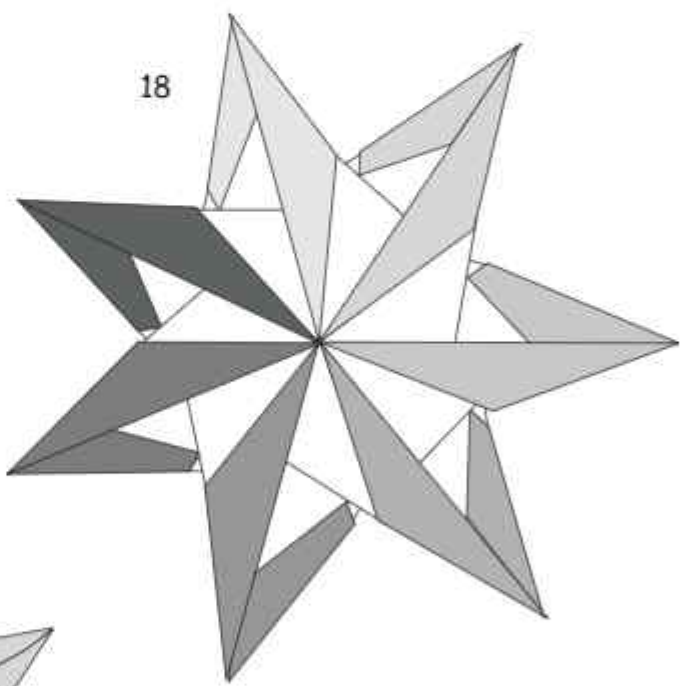
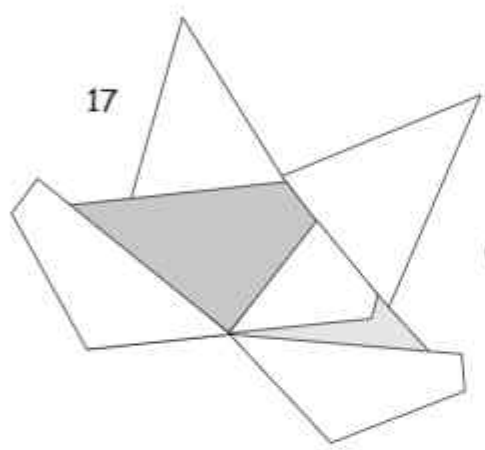
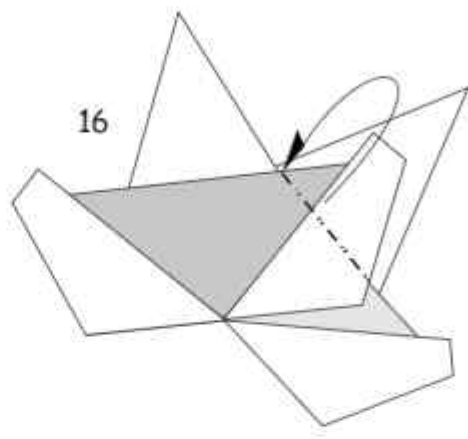

Con 5 moduli possiamo fare un fiore



**ORIGAMI
ARGENTINA**

Asociación Civil Plegando al Sur

**6^o CONVENCION
DE ORIGAMI
ARGENTINA**

TUCUMÁN 2022

Nivel 2

8 papeles bifaz de 7,5x7,5

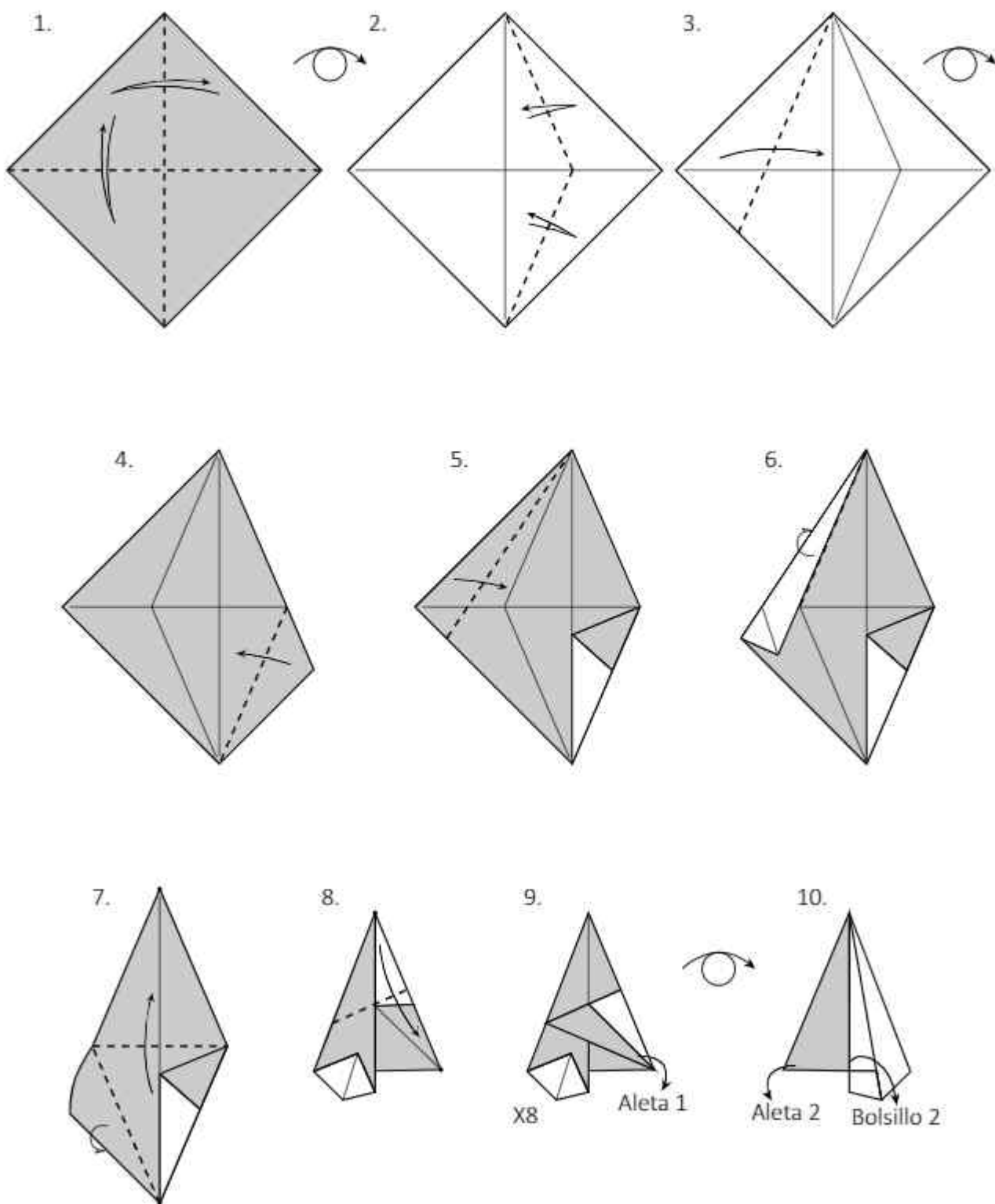

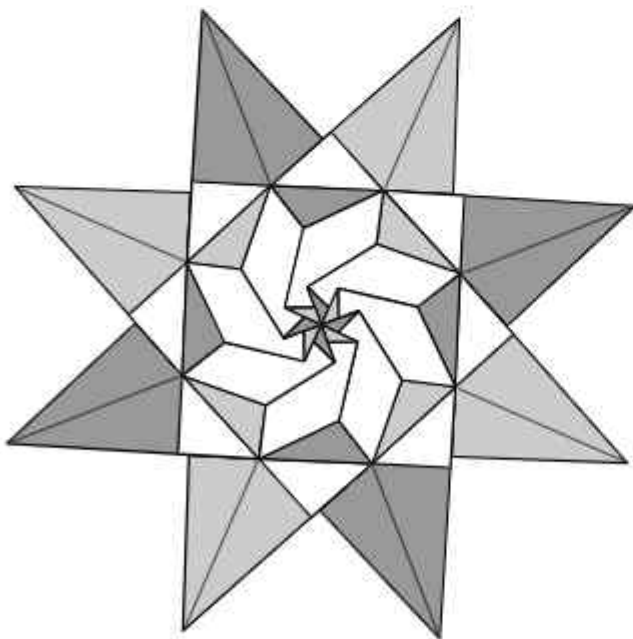
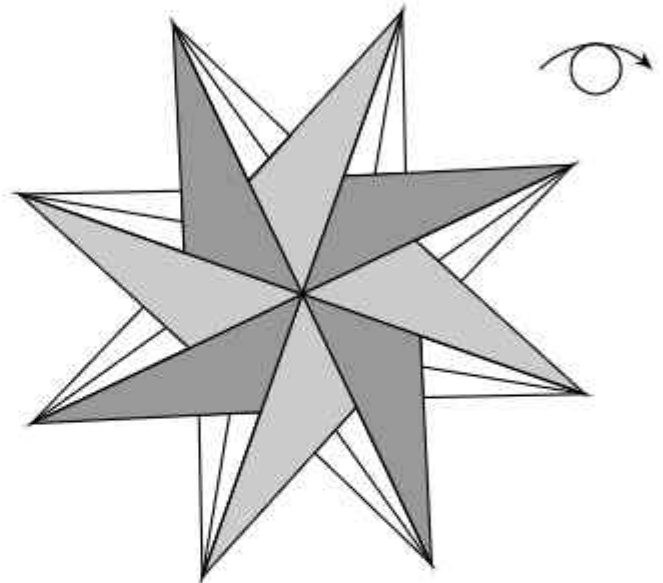
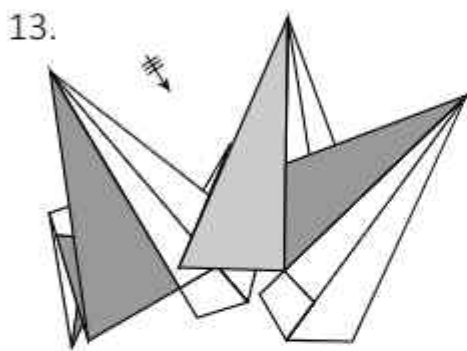
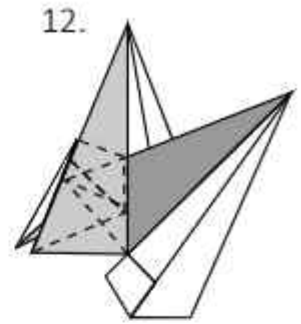
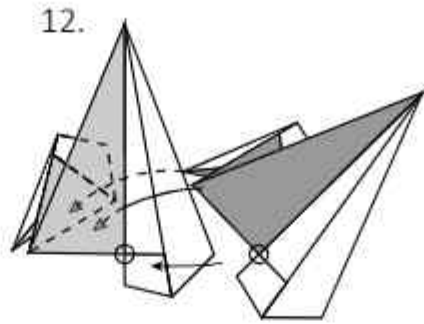
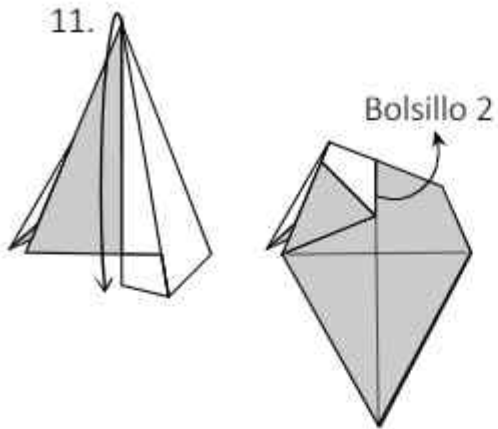

Frente.

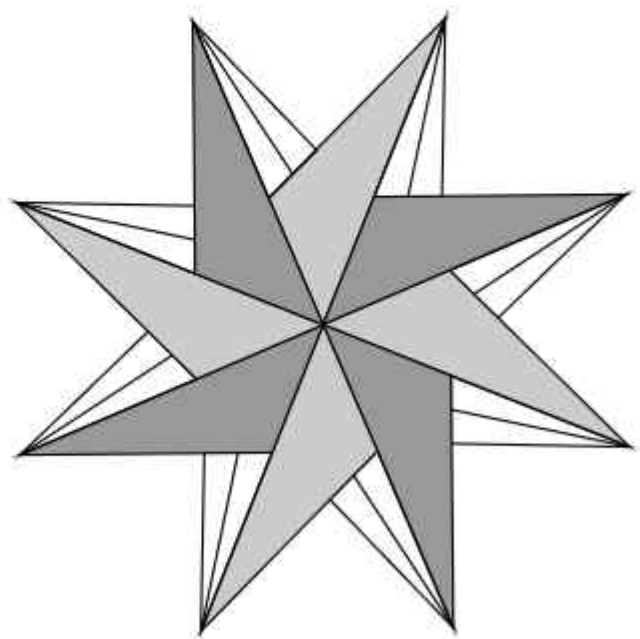

Reverso.

8 papeles bifaz de 7,5x7,5

1.

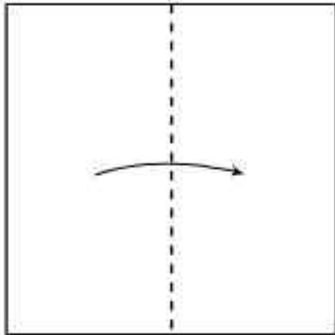

2.



3.

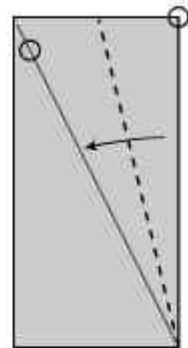

4.

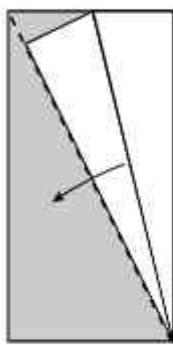

5.

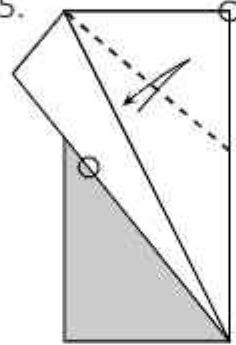

6.

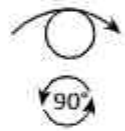
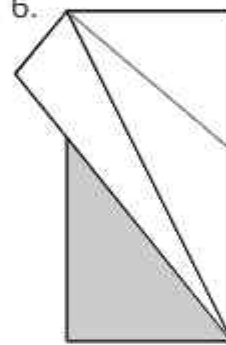

7.

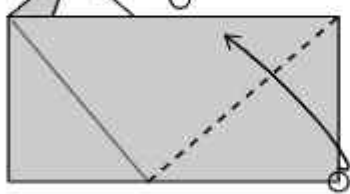

8.

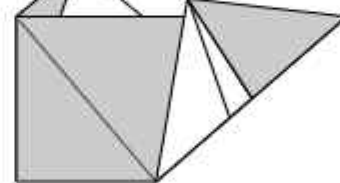

9.

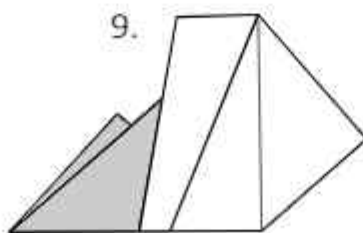

x8

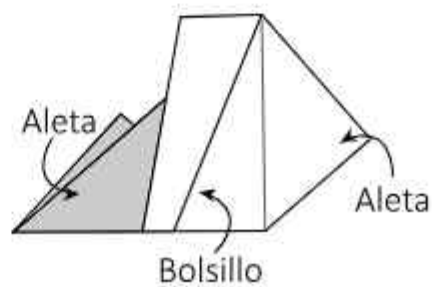

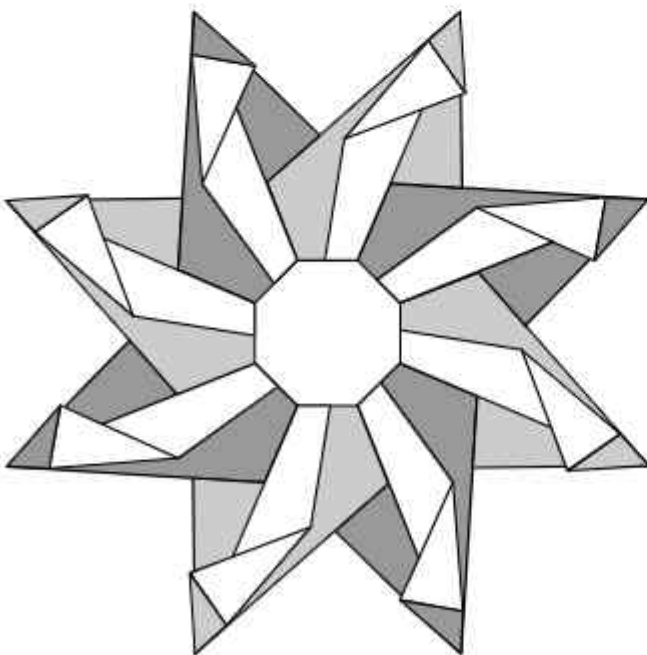
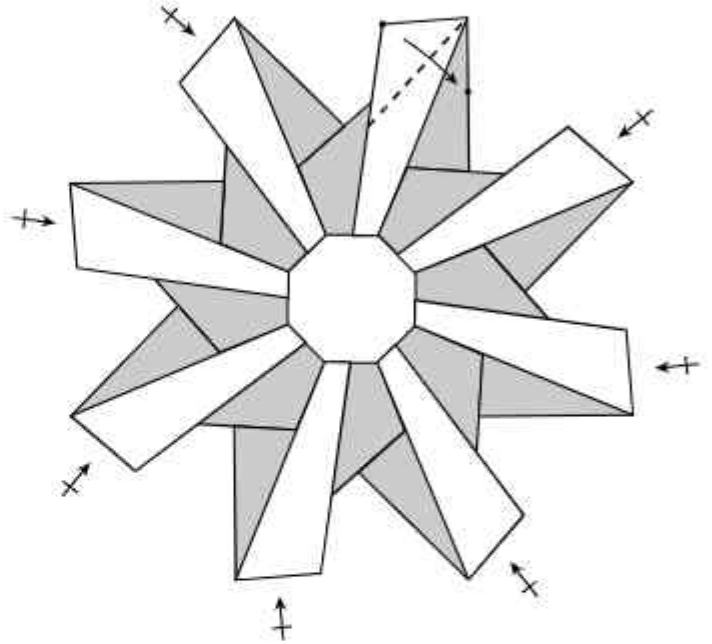
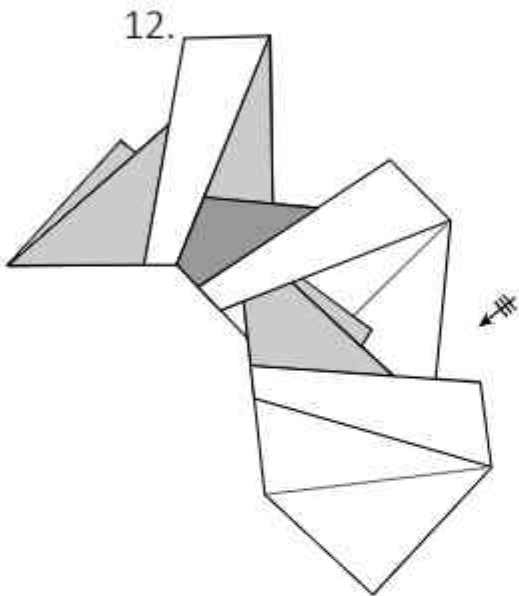
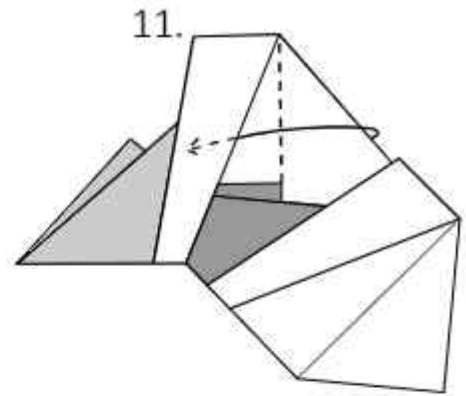
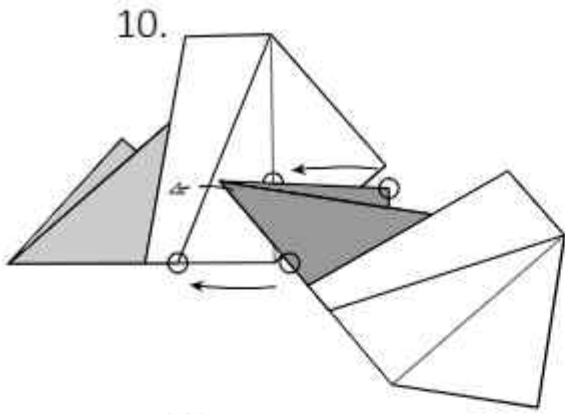

Frente.

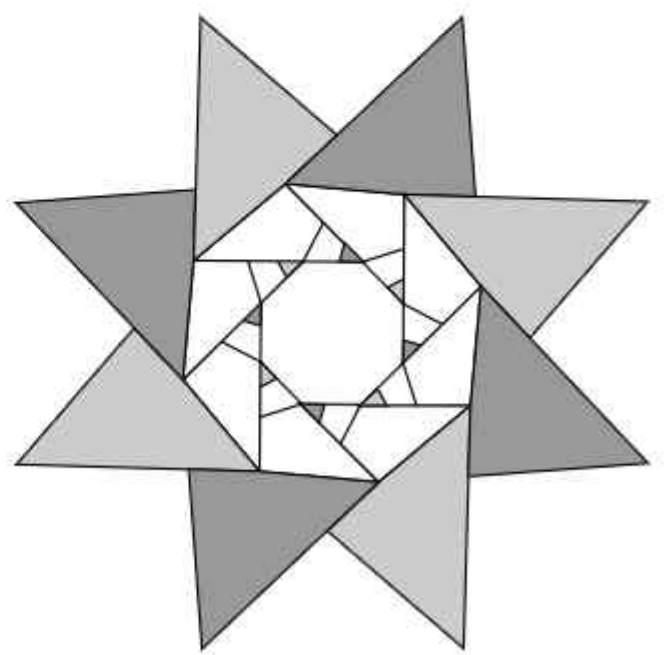

Reverso.

Piedra Luminosa de Aldos Marcell

@marcellaldos

Diagramas, Pedro Aparicio @tallerdelaribera

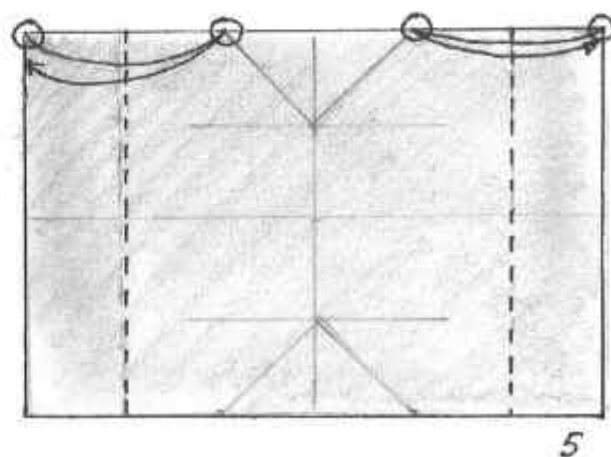
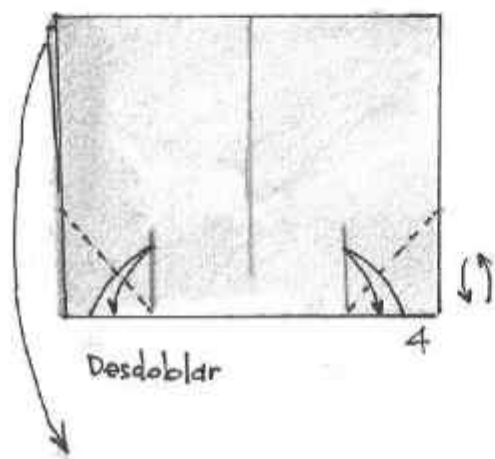
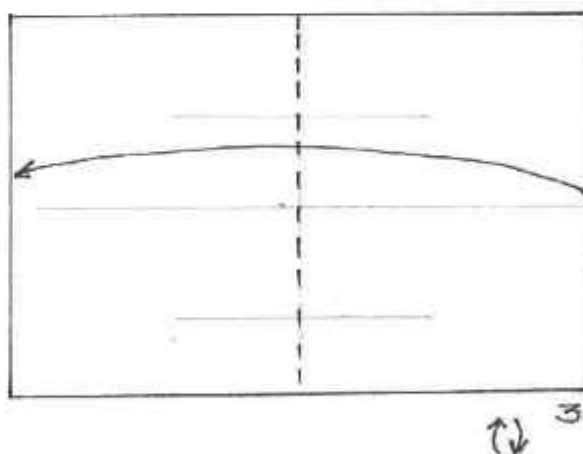
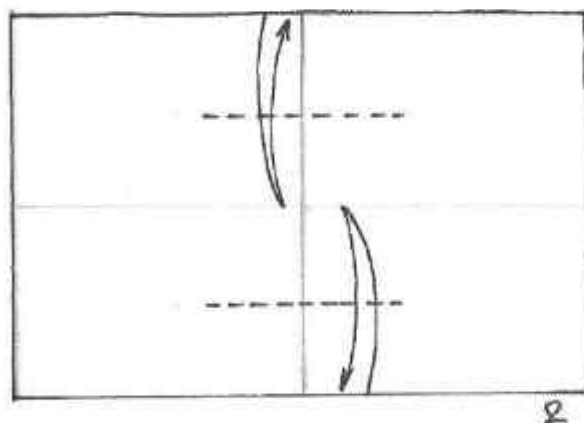
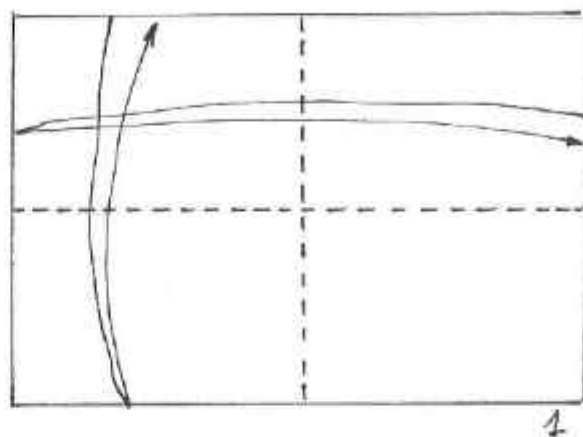
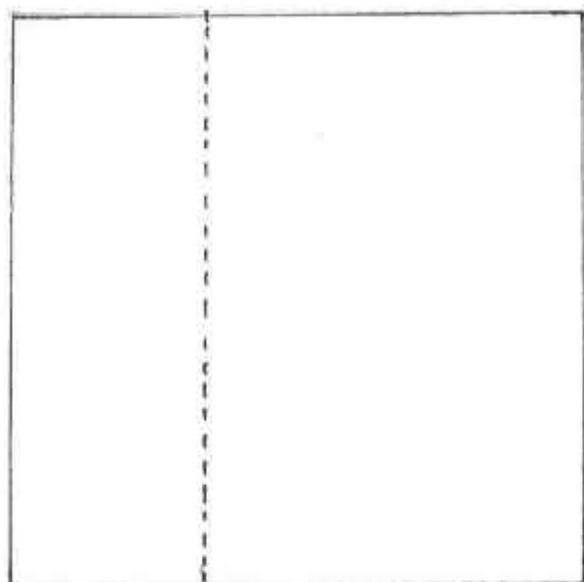

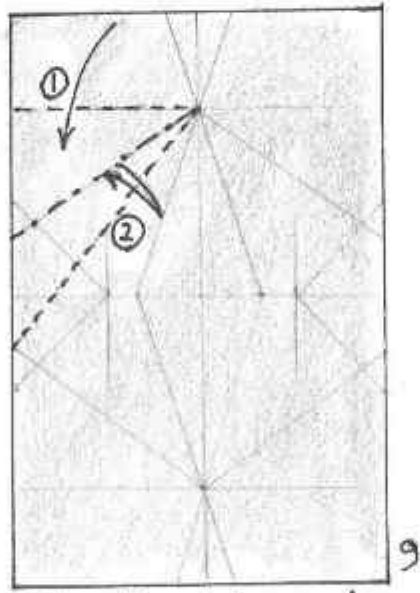
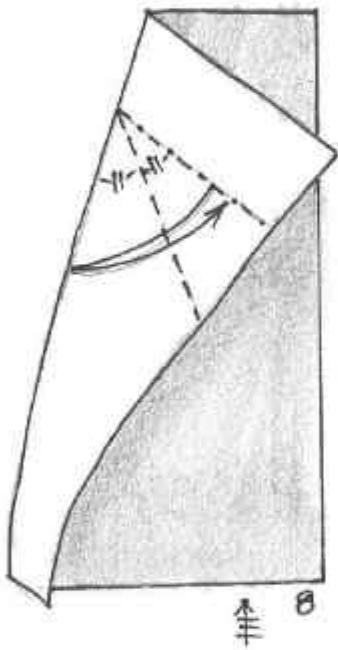
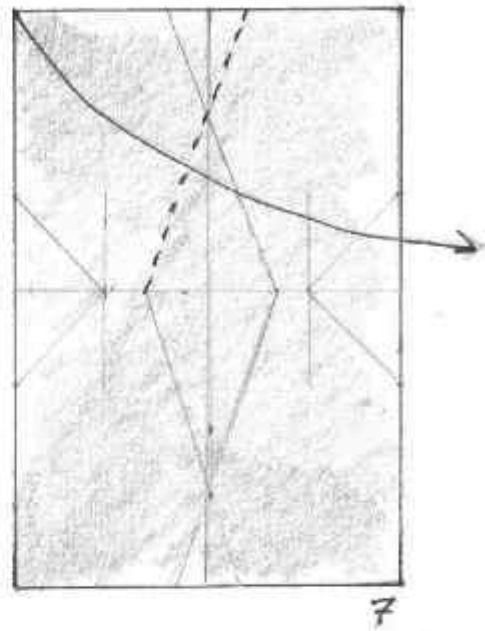
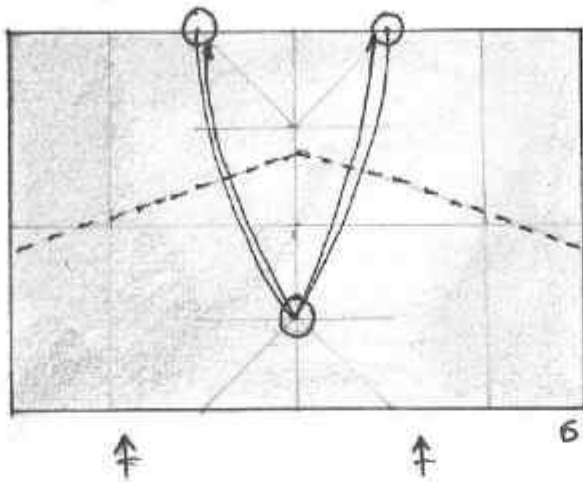

- ① Levantar un poco
- ② marcar la bisectriz

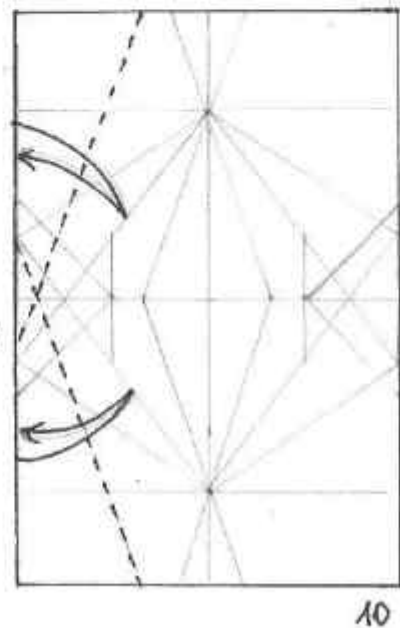

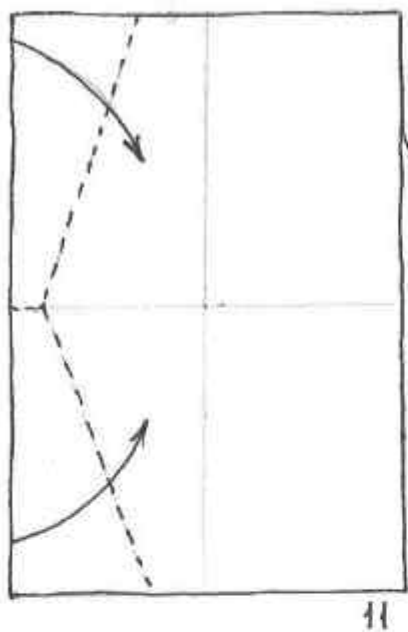

11

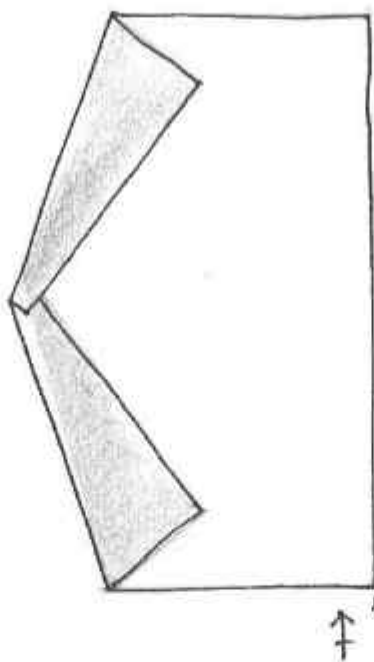

12

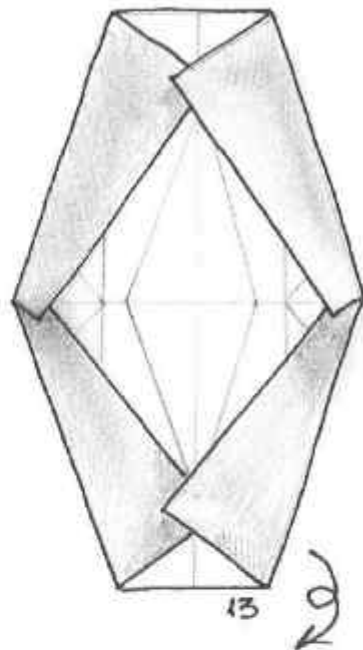

13

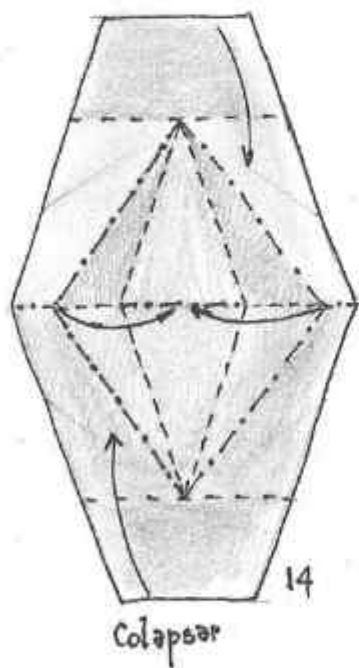

14

Colapsar

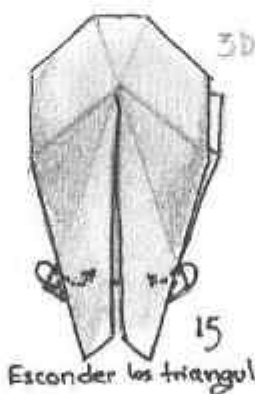

15

Esconder los triangulitos

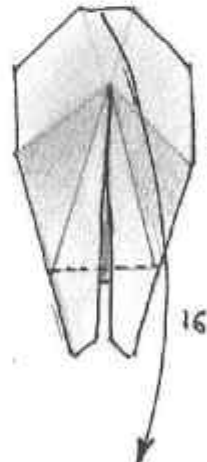

tridimensión

16

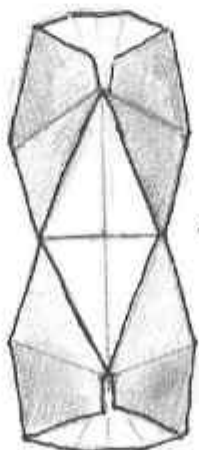

Frente

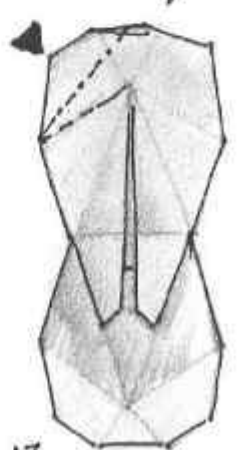

17

Dorso

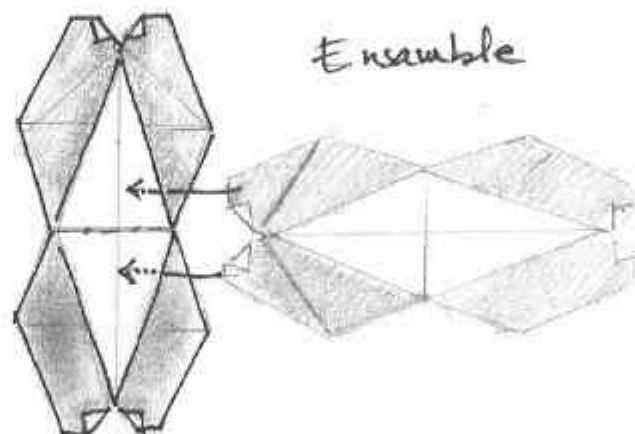
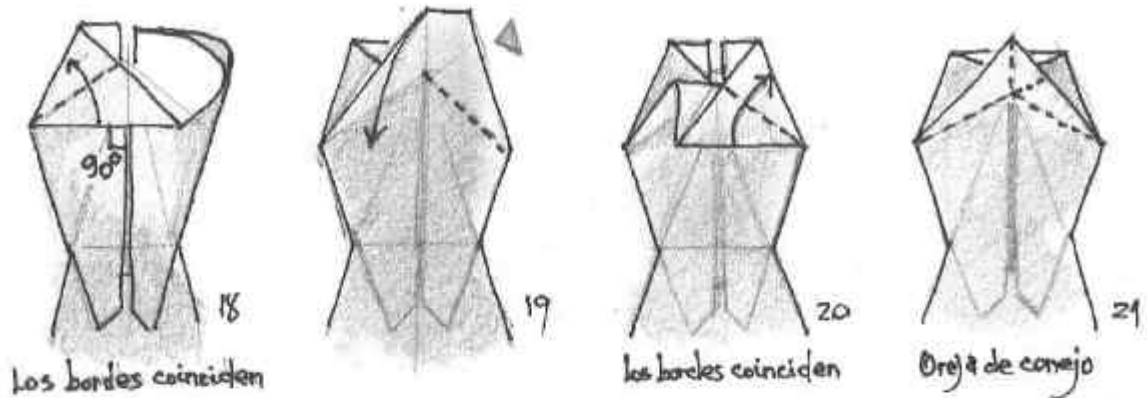

módulo terminado
x 6

Los módulos ensamblan de manera perpendicular introduciendo las aletas por debajo del rombo blanco. Al cerrar la pieza adquiere fortaleza

Bebé Dragón 1.0 / Francesco Massimo

Francesco Massimo

Designed / Diseño:
05/2021

Double colored paper: No
/ Papel doble color: No

Recommended paper
/ Papel recomendado:
< 50-60 gsm,
> 15 cm x 15 cm

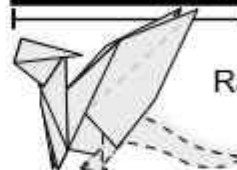
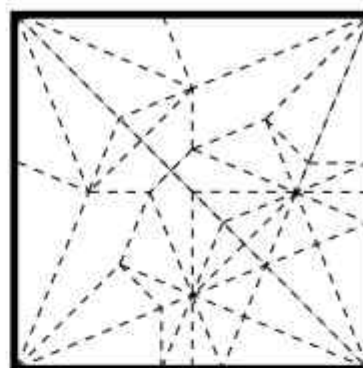
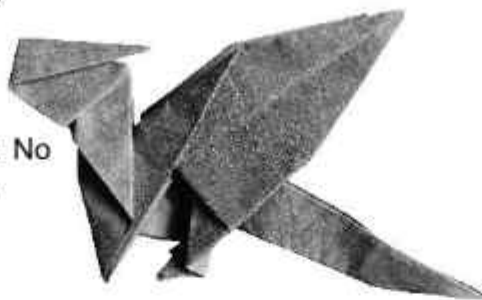

Ratio: 0.65

Level: lower intermediate / Nivel: bajo intermedio

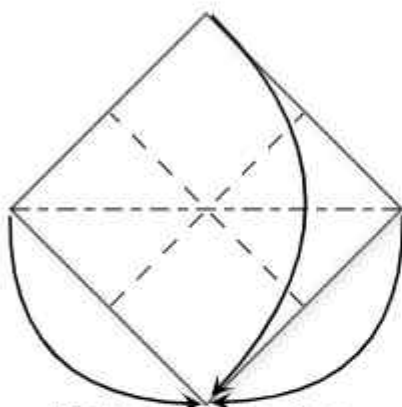

1. Fold a Preliminary Base.
Doblar una Base Preliminar.

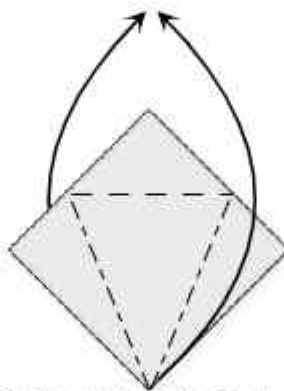

2. Petal-fold in the front and behind to form a Bird Base.
Doblar en petalo en frente y atrás para formar una Base Pajaro.

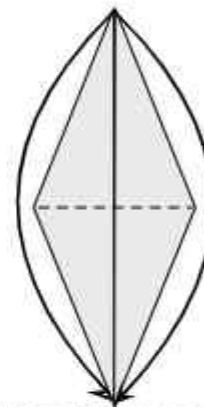

3. Fold down the upmost flap. Repeat behind.
Doblar abajo la aleta arriba. Repetir atrás.

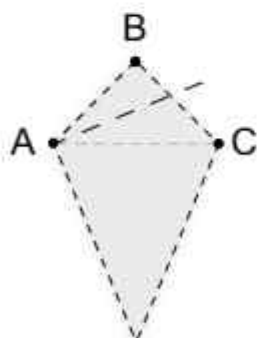

4. Precrease superposing line AB with line AC. Then, reopen the model, colored side up.
Predoblar sobreponiendo la línea AB a la línea AC. Después, reabrir el modelo, lado colorado arriba.

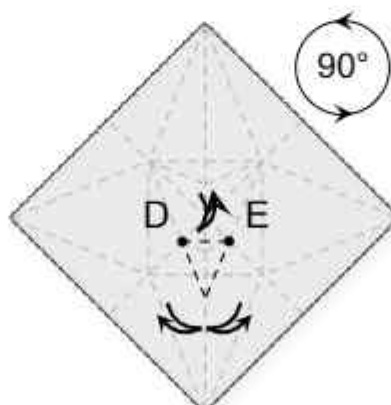

5. Precrease connecting points D and E. Precrease extending two lines passing through those points. Rotate by 90°.
Predoblar conectando los puntos D y E. Predoblar alargando dos líneas que pasan por estos puntos. Girar de 90°.

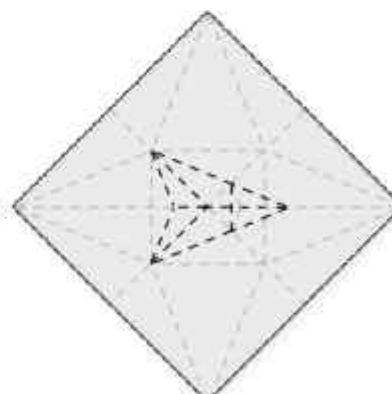

6. Focus on the mountain and valley-folds in the figure, but do not fold them yet.
Concentrarse sobre los pliegues en montaña y en valle en la figura, todavía sin doblarlos.

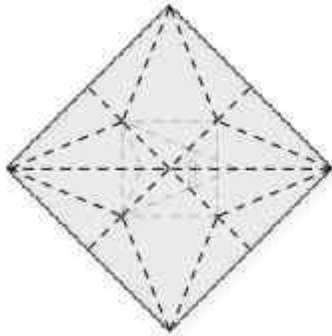

7. Re-fold the Bird Base as it was placed in step 4.
Re-doblar la Base Pajaro tal como estaba en el paso 4.



8. Open-sink. The sink part should follow the mountain and valley folds shown in step 6.
Hundir. La parte hundida debería seguir los pliegues en montaña y en valle mostrados en el paso 6.

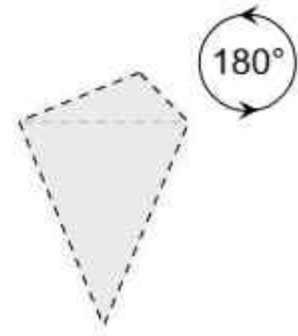

9. Rotate the model.
Girar el modelo.

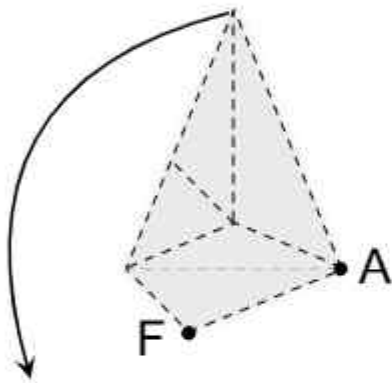

10. Start folding the vertical line and then superpose the right border to line AF. Then, fold inside the left part. Repeat behind.
Doblar abajo las alas para alinear sus bordes con la línea AF.

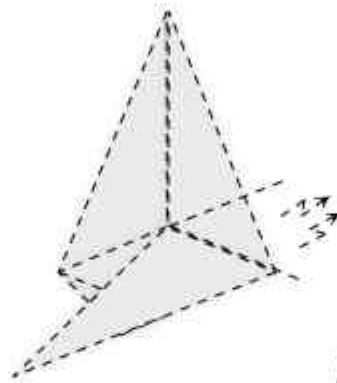

11. Crimp to form the tail. The valley fold would arrive to point G of the previous figure if extended.
Doblar en zigzag para formar la cola. El pliegue en valle llegaría al punto G si fuera extendido.

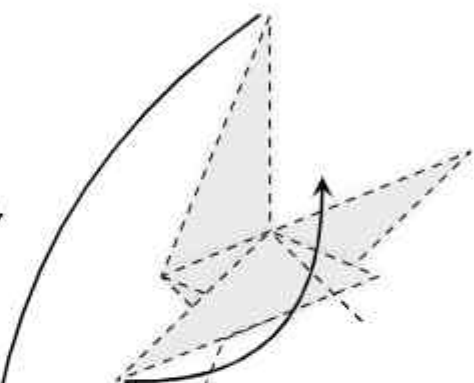

12. Fold down the head flap pulling out the paper and at the same time bring the wings upwards to the other side.
Doblar abajo la aleta de la cabeza sacando papel y al mismo tiempo llevar las alas arriba al otro lado.

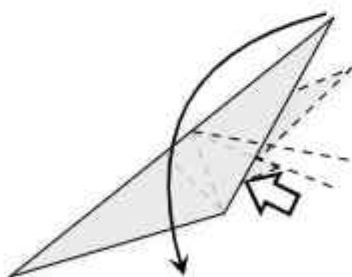

13. Squash-fold the wings.
Abrir y aplastar las alas.

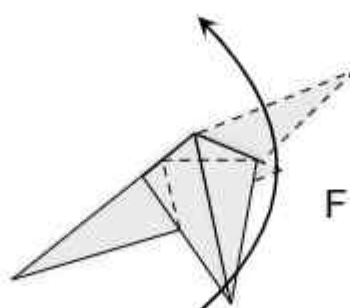

14. Petal-fold the wings.
Doblar en petalo las alas.

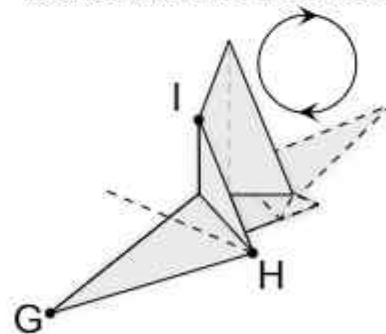

15. Reverse the neck-head flap, aligning line GH with line HI. Rotate the model.
Invertir la aleta del/la cuello/cabeza, alineando la línea GH con la línea HI. Girar el modelo.

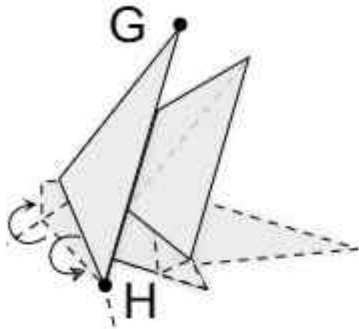

16. Fold inside the paper in excess from the chest.
Doblar adentro el papel en exceso del pecho.

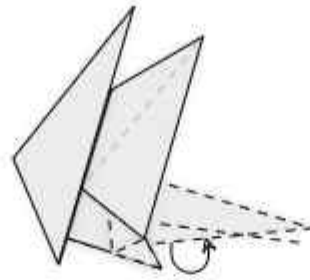

17. Narrow the tail folding inside some paper.
Adelgazar la cola doblando adentro un poco de papel.

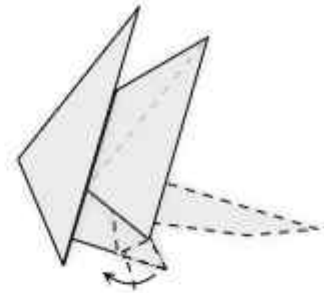

18. Form the rear legs.
Formar las patas posteriores.

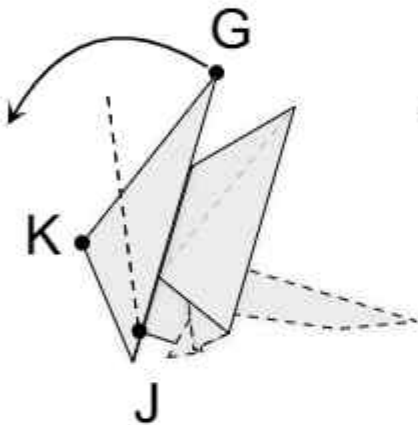

19. Form the head with a reverse fold. Line GJ should intersect point K.
Formar la cabeza con un pliegue invertido. La línea GJ debería pasar por el punto K.

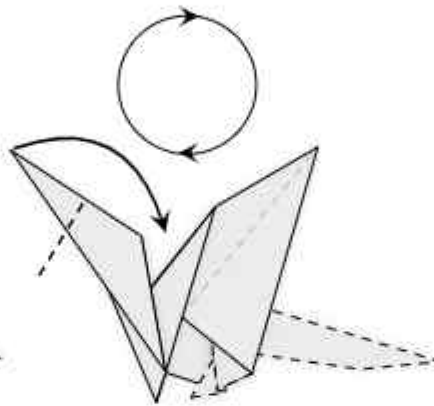

20. Reverse the flap to form the horn. Make the dragon sit on its legs.
Invertir la aleta para formar el cuerno. Posicionar el dragón para que se asiente sobre sus pies.

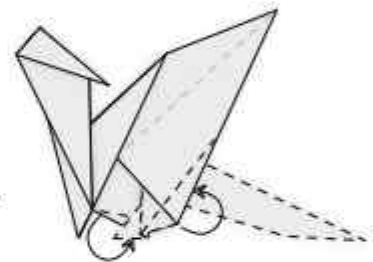

21. Narrow the belly and the lower part of the wings folding inside some paper.
Adelgazar el ventre y la parte baja de las alas doblando adentro un poco de papel.

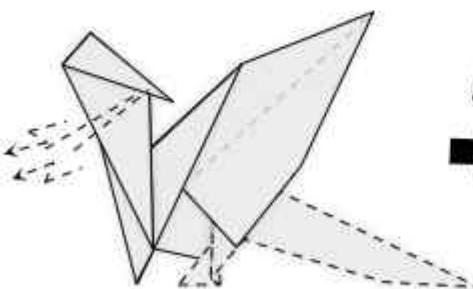

22. Crimp to lower the head.
Doblar en zigzag para bajar la cabeza.

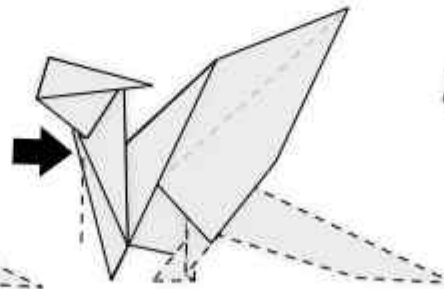

23. Sink some paper from the chest. Shape the tail.
Hundir un poco de papel desde el pecho. Moldear la cola.

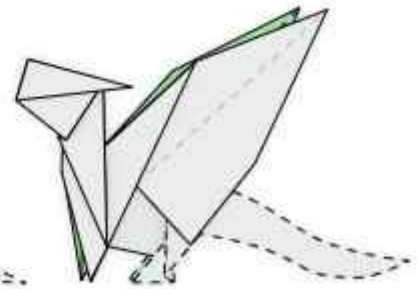

24. Finished model.
Modelo terminado.

Cerdito / Eszti Gyorik

CERDITO 🐷

Creadora: Eszti Györík
Diagrama: Morgan Lozano
Medida Recomendada: 15cm

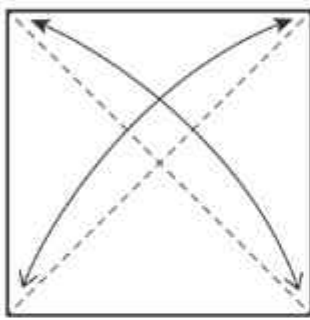
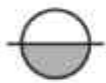
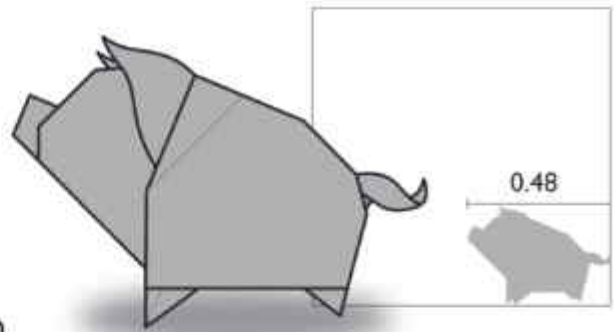

1.

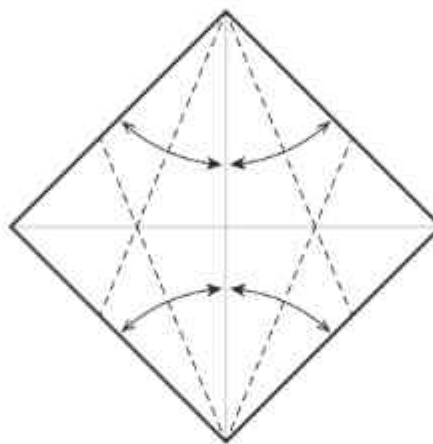

2.

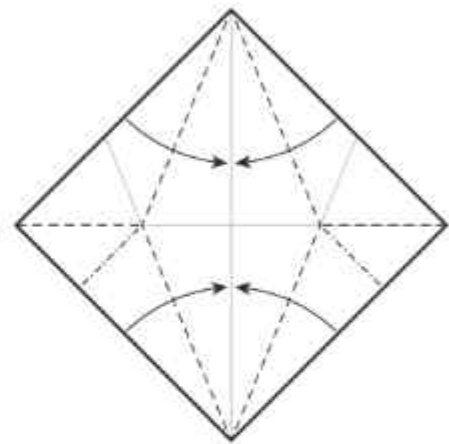

3. Colapsar como se indica (base pez).

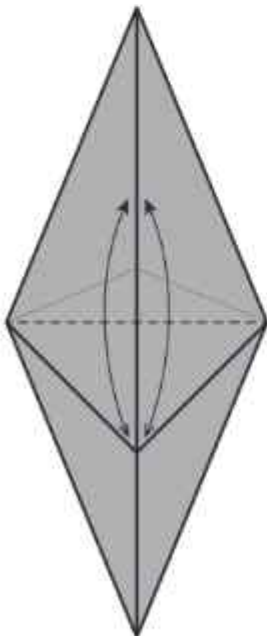

4. Doblar y desdoblar.

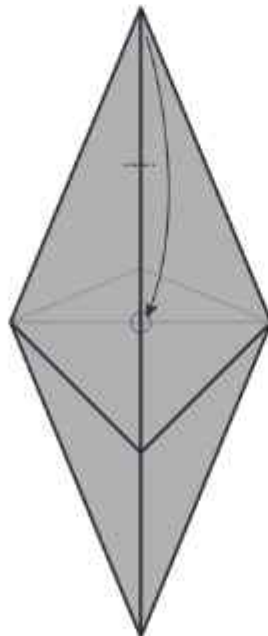

5. Marcar hasta la referencia.

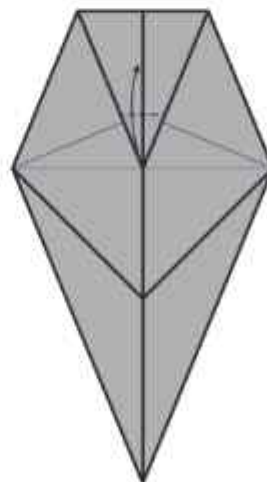

6. Doblar en valle usando las marcas de abajo como referencia.

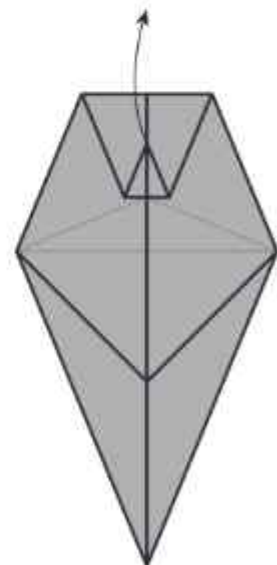

7. Desdoblar la punta.

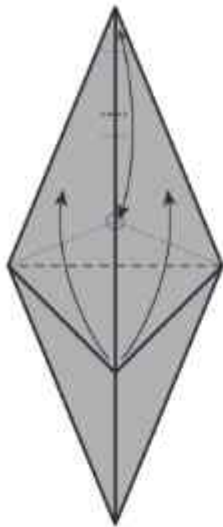

8. Doblar hasta la referencia y subir las aletas.

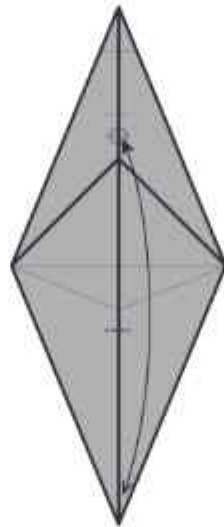

9. Doblar hasta la referencia.

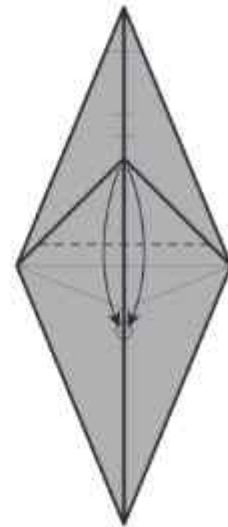

10. Doblar las aletas hasta la referencia.

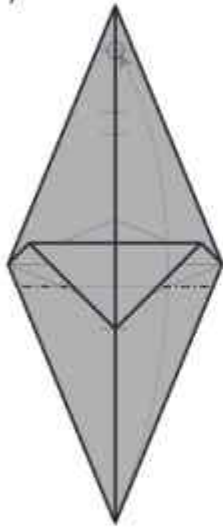

11. Doblar en monte hasta la referencia.

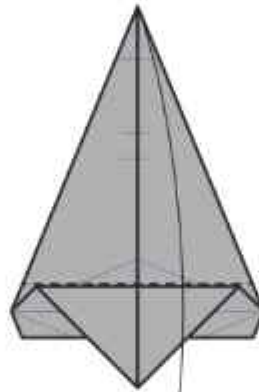

12. Doblar en valle la capa frontal.

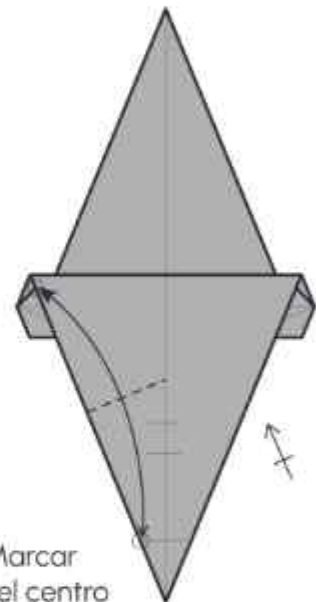

13. Marcar hasta el centro uniendo los puntos de referencia. Repetir en la derecha.

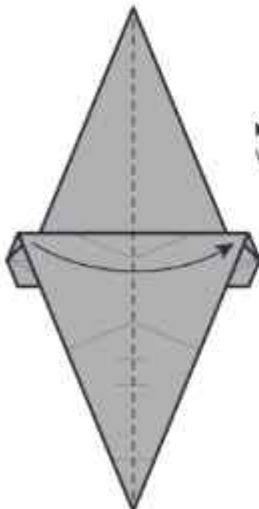

14. Doblar en valle por la mitad y rotar.

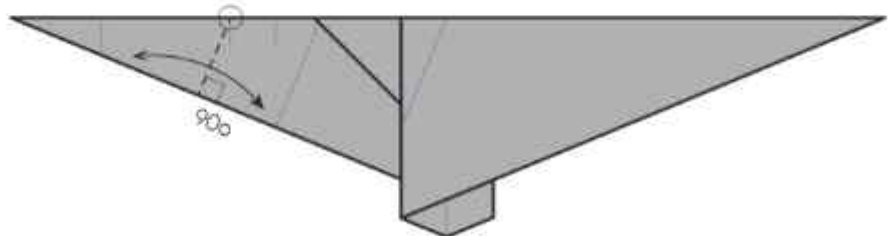

15. Doblar y desdoblar en ángulo recto desde el punto de referencia.

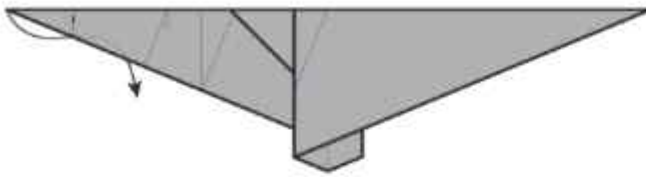

16. Doblar invertido hacia dentro para formar la nariz.

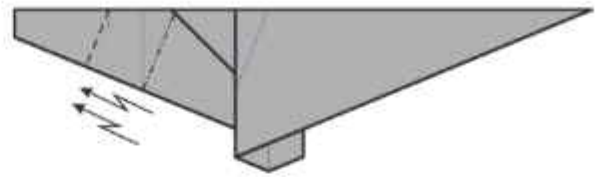

17. Doblar escalonado simétrico para formar la cabeza.

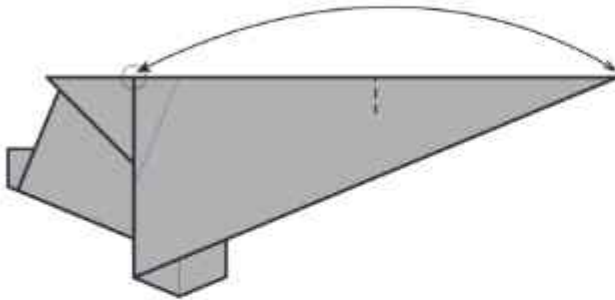

18. Marcar hasta la referencia.

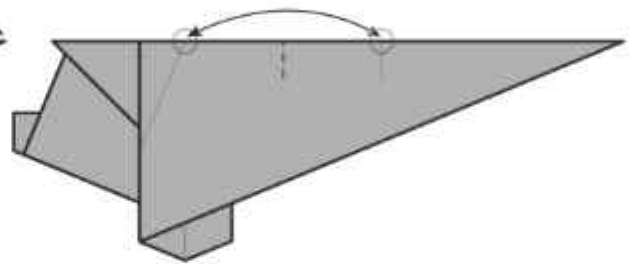

19. Marcar usando los puntos de referencia.

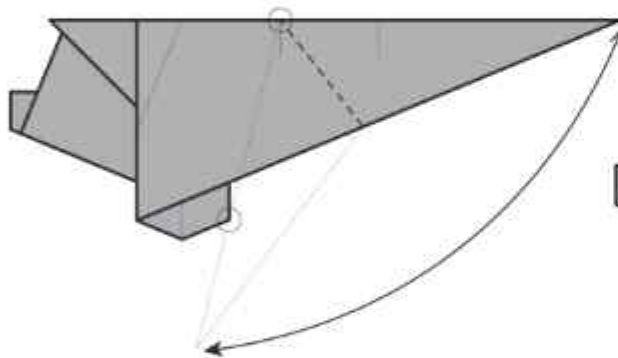

20. Doblar y desdoblar desde la marca alineando el borde de la capa con la punta de la pata.

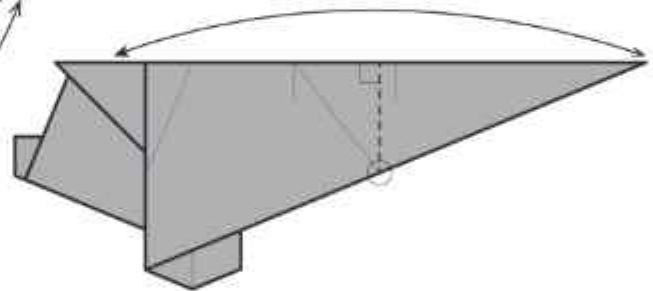

21. Doblar y desdoblar en ángulo recto desde el punto de referencia.

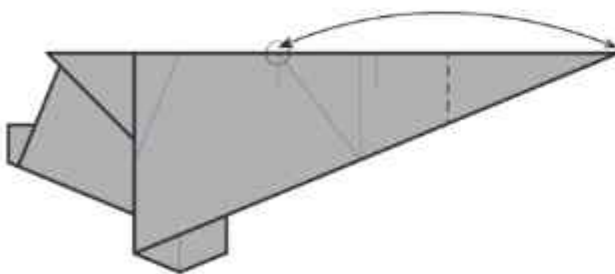

22. Doblar y desdoblar la punta hasta la referencia.

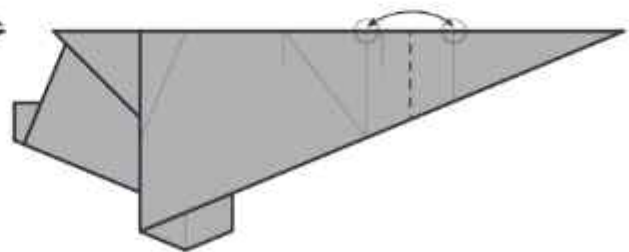

23. Doblar y desdoblar por la mitad de los puntos de referencia.

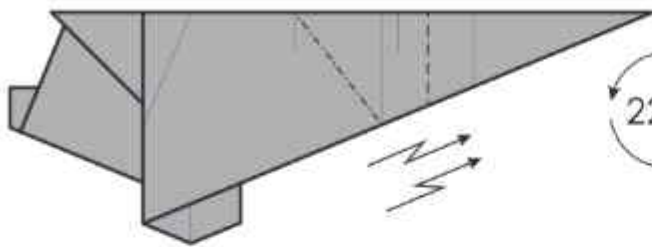

24. Doblar escalonado simétrico para formar el cuerpo y la cola.

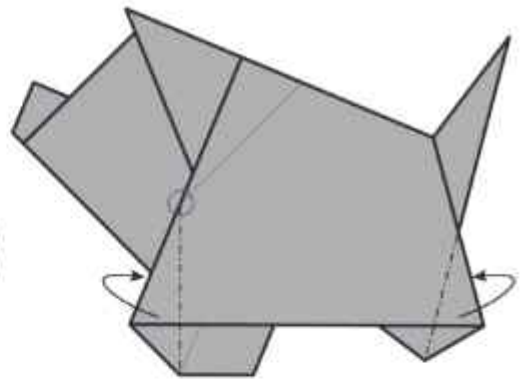

25. Doblar en monte las patas; a través del borde de la cola y el punto de referencia. Repetir por detrás.

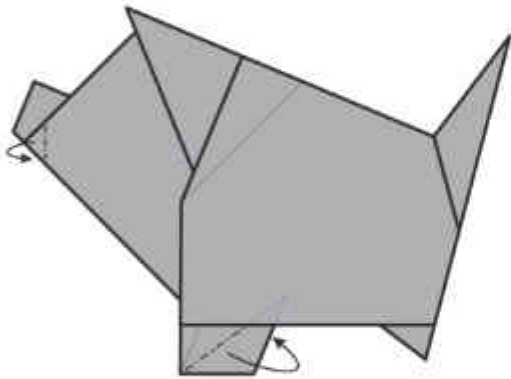

26. Doblar a gusto la pata delantera y el frente de la nariz. Repetir por detrás.

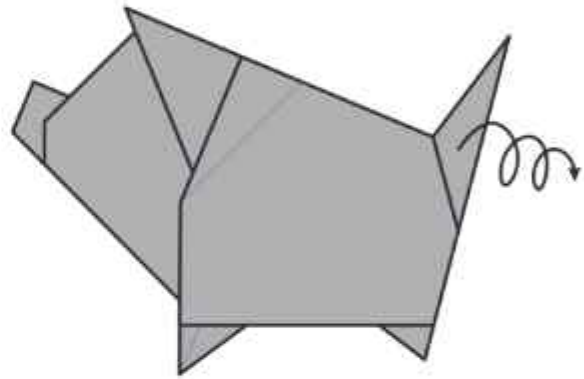

27. Curvar la cola.

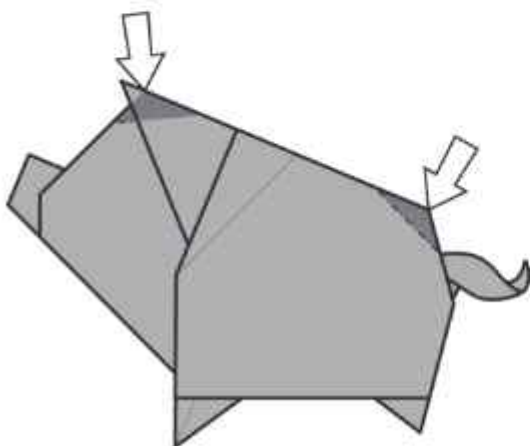

28. Hundir en la frente y detrás del cuerpo.

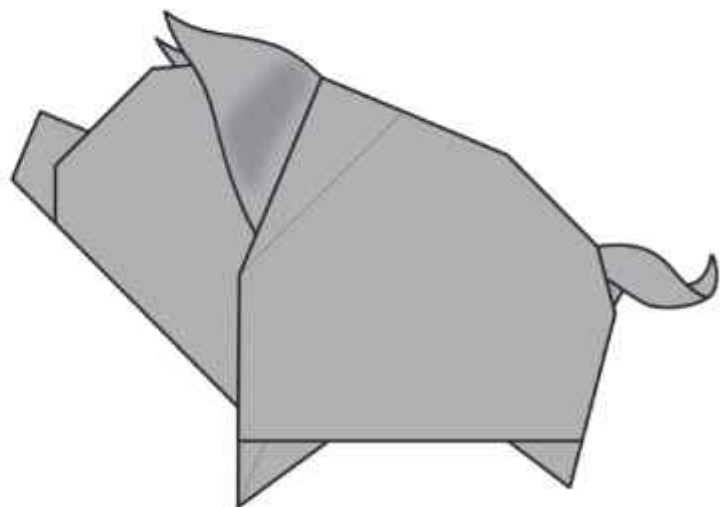

MODELO TERMINADO

Zorrillo / Oz Neyer

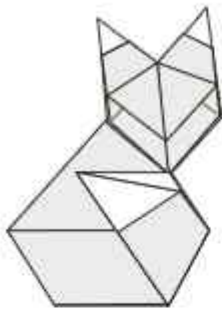

ZORRITO

V.1.0

Autor: @ozneyer

Diagrama: @dread_control

Tamaño recomendado: 10cm

Creación: 2018

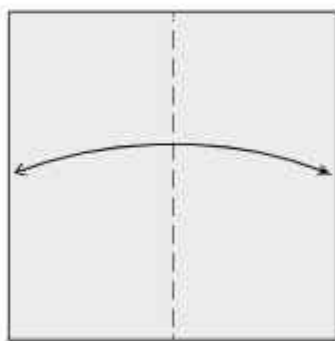

1

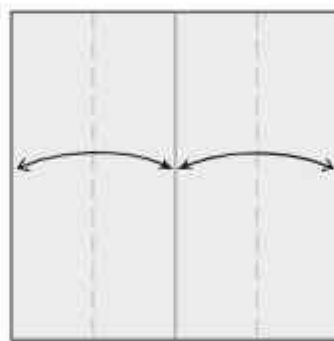

2

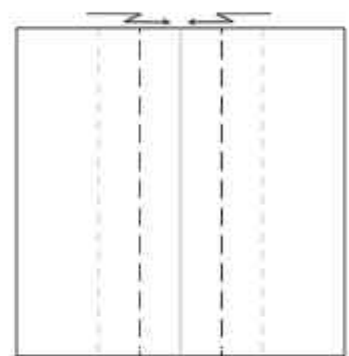

3

Escalonar
hacia el centro.

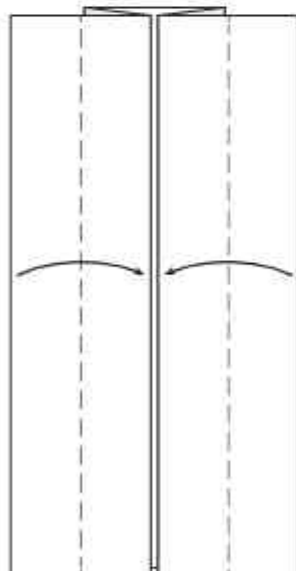

4

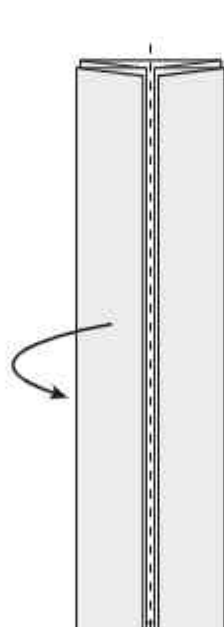

5

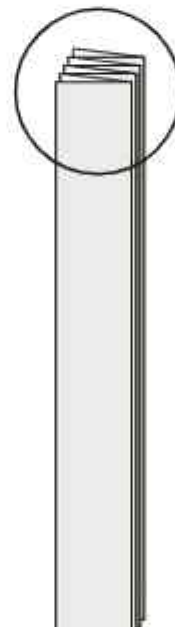

6 Zoom.

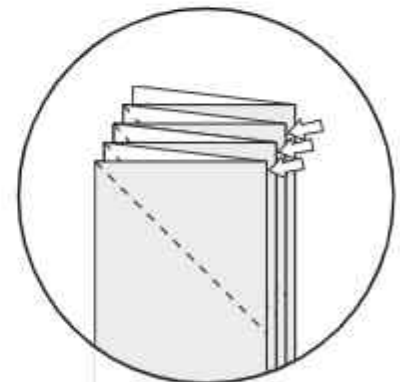

7

Revertir las 3
primeras puntas.

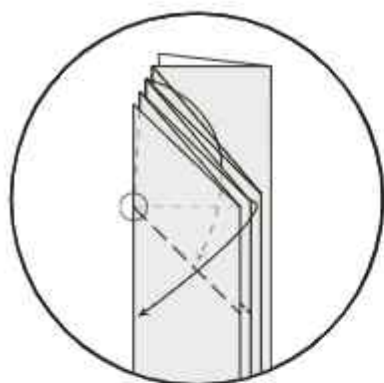

8 Abrir y aplastar por en medio de las capas, doblando justo por debajo de las puntas.

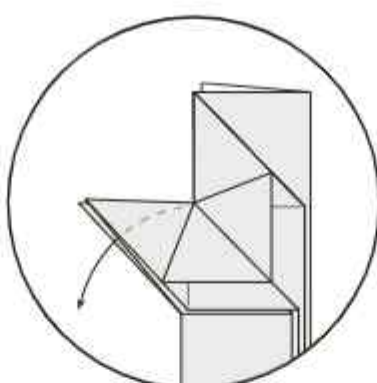

9 Liberar la capa atrapada.

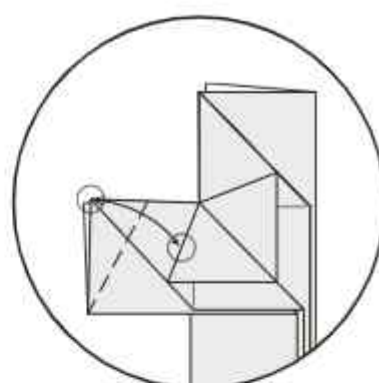

10 Doblar la capa frontal, llevando la punta al borde indicado y desdoblar.

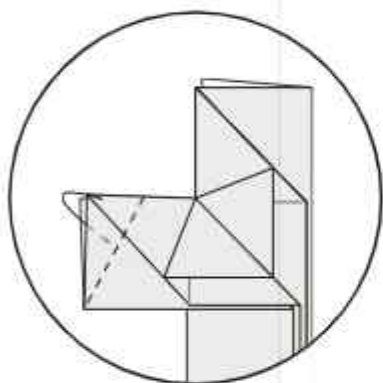

11 Esconder la capa hacia atrás.

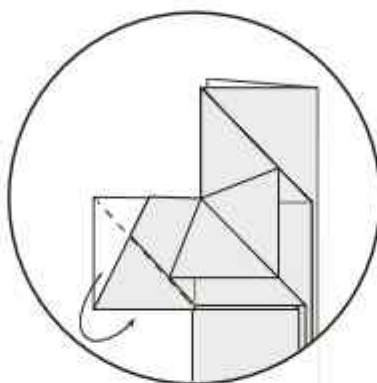

12 Esconder el resto sobre el borde.

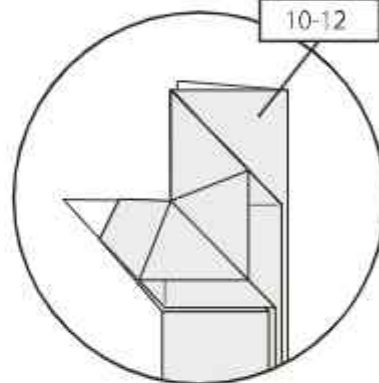

13 Repetir. Zoom fuera.

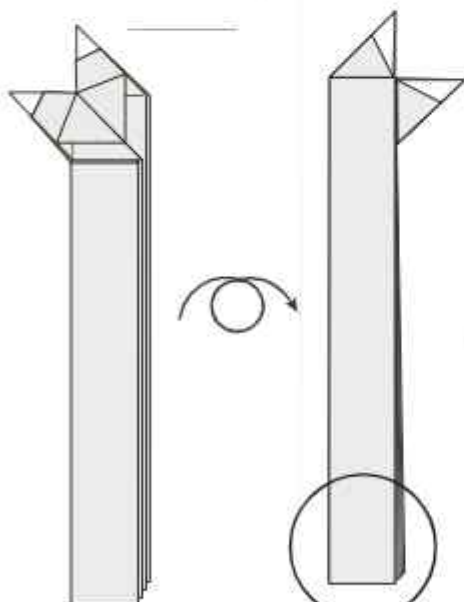

14

15 Zoom.

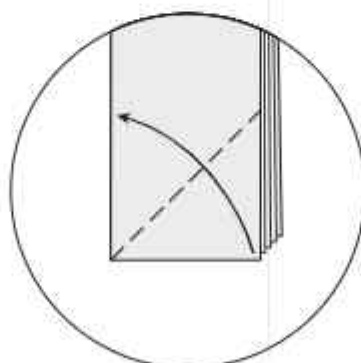

16 Doblar en valle una capa.

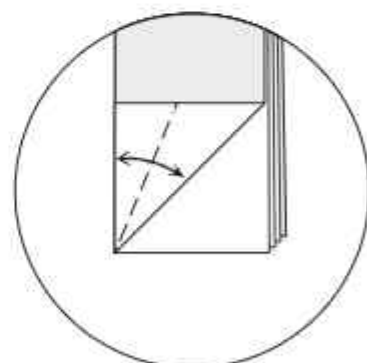

17 Doblar labisectriz.

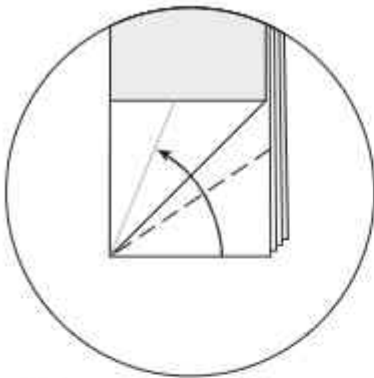

18 Doblar la siguiente punta juntando los bordes.

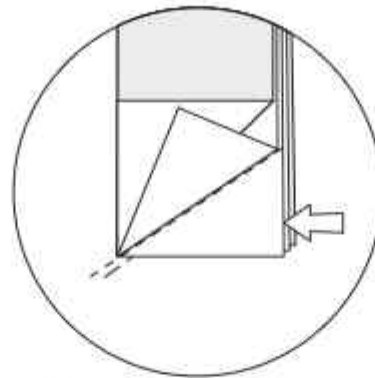

19 Revertir la siguiente punta sobre el borde.

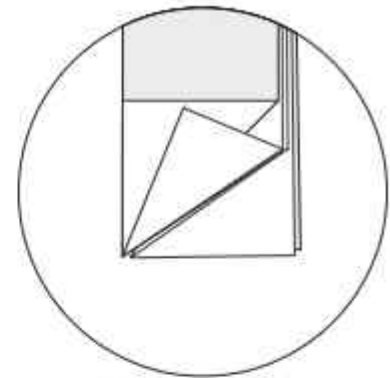

20 Zoom fuera.



21



22 Doblar en valle las 2 capas restantes.



23 Doblar usando las referencias.



24 Doblar la cola en valle. Observa las referencias en el siguiente paso.



25 El doblar debe coincidir con los puntos indicados.

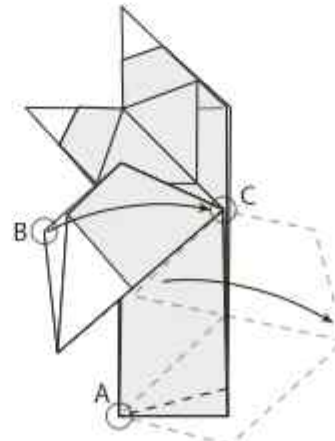

26 Rotar la cola desde el punto "A", llevando el punto "B" hacia el "C".

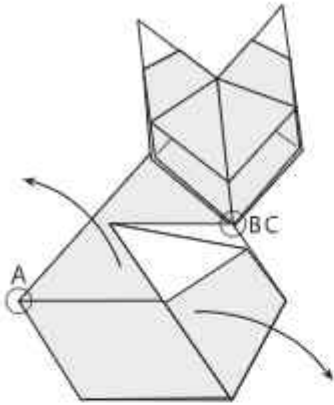

27 Separar las capas para entrelazarlas.

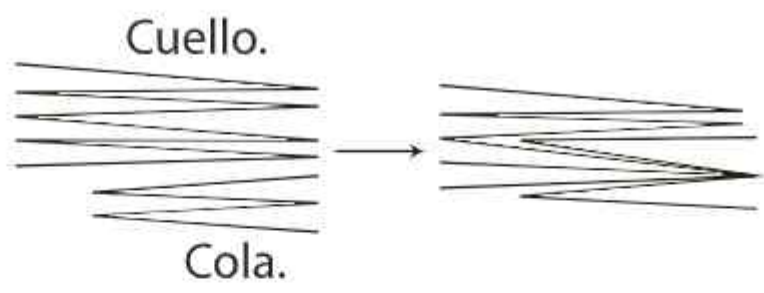

28 Introduce la solapa trasera de la cola en medio de las capas del cuello.

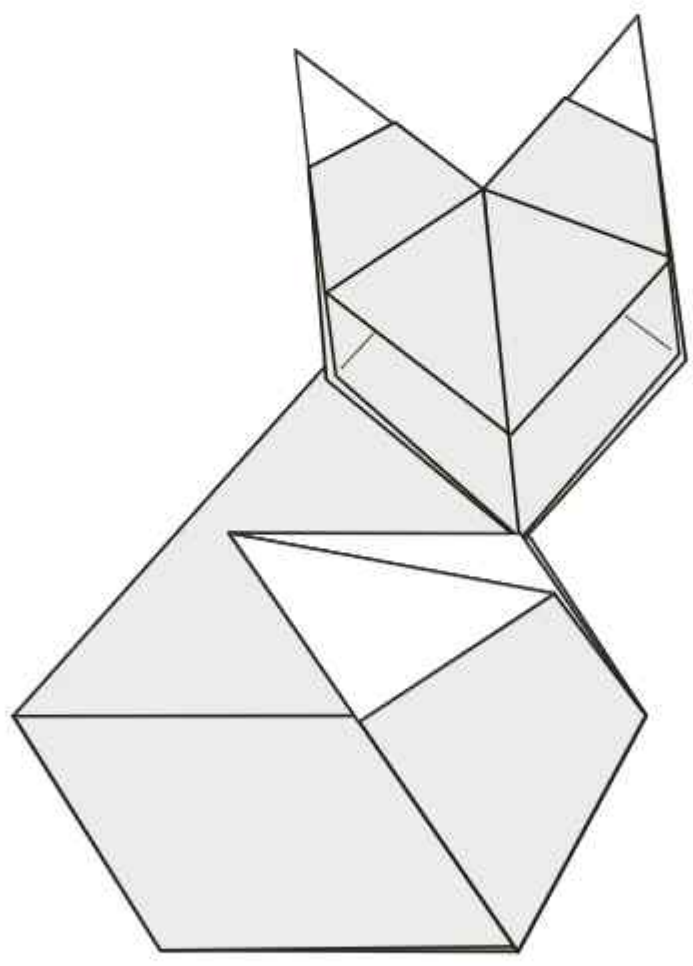

Modelo Terminado.
Versión I

Twirls Fortune / Krystyna Burczyk



**Creator: Krystyna Burczyk
(12.02.2021)**

**Diagrams: Krystyna & Wojtek
Burczyk (2021)**

K21045

Difficulty level: Intermediate. 30 modules.
Diameter 15 cm out of 9 x 18 cm rectangles.
Recommended paper: heavy (100-120 g/m²)
paper with good tension.

Module

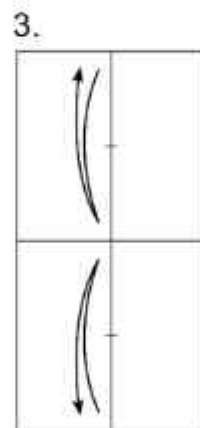
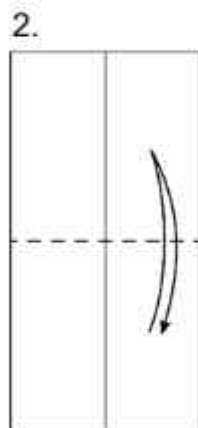
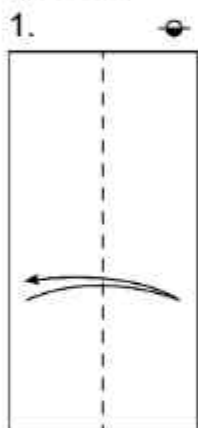

Pinch only.

Fold to the pinch.

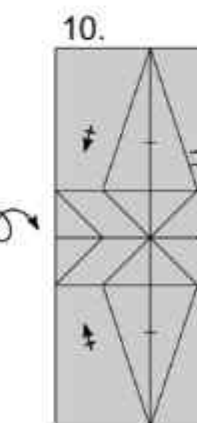
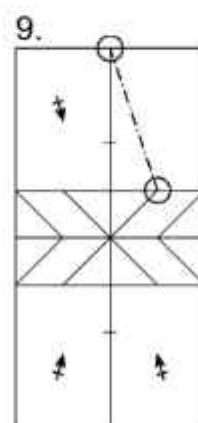
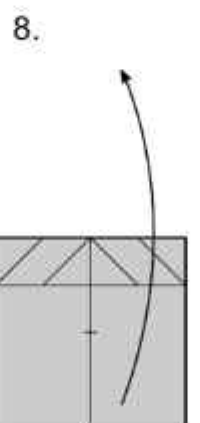
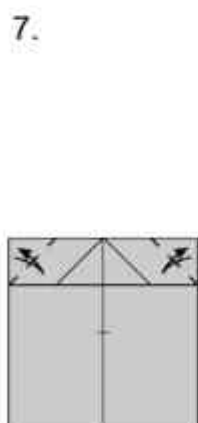
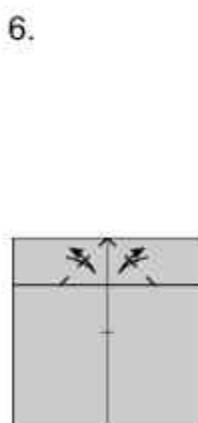

Fold to the first
line only.

Unfold.

Fold a mountain
line between the
points.
Repeat around.
Turn the paper
over.

Bisect.
Repeat
around.

Collapse

11.

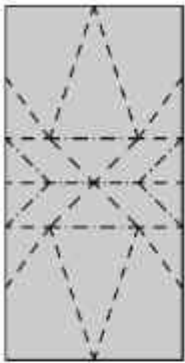

Check the direction of the lines.
 Refold where necessary.
 Turn the paper over.

12.

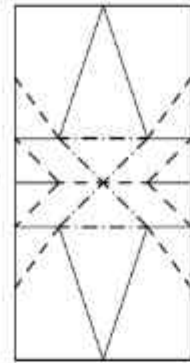

Collapse a waterbomb at the center.
 Use the lines shown.

13.

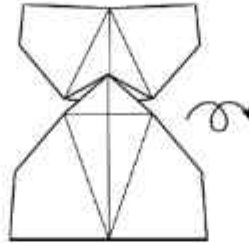

Turn the paper over.

14.

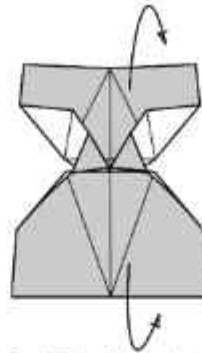

Fold back to close the module.
 The middle part of the module will not be flat.

15.

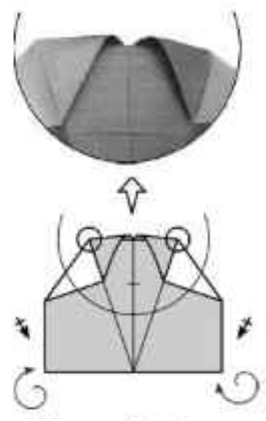

The marked points are not flat-foldable and add volume to the top part.
 Twist the flaps into spirals (each layer separately).

16.

The module is ready.



Top view.



Bottom view.



Front view.



Side view.

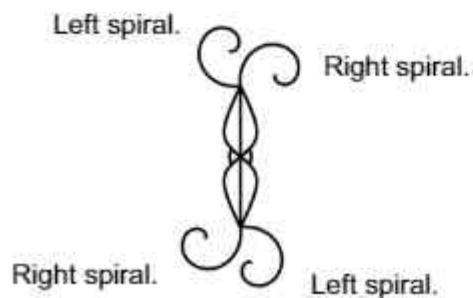

x 30

Assembly

The model is based on the structure of the icosidodecahedron. Modules correspond to vertices. There are 12 vortexes of 5 spirals corresponding to pentagons and 20 vortexes of 3 spirals corresponding to triangles.



17.

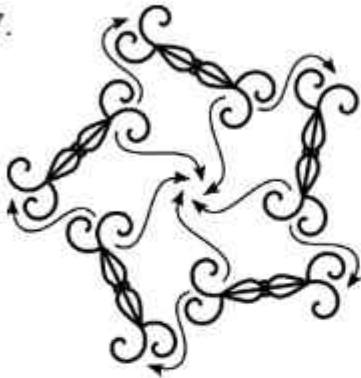

Join 5 modules.

Pay attention to the orientation of the modules and the spirals (right to right, left to left). The right spirals join in the center of the macro-module. The left spirals join pairwise outside the macro-module.

18.



The vortex of 5 spirals corresponds to a pentagonal face of the icosidodecahedron.

19.

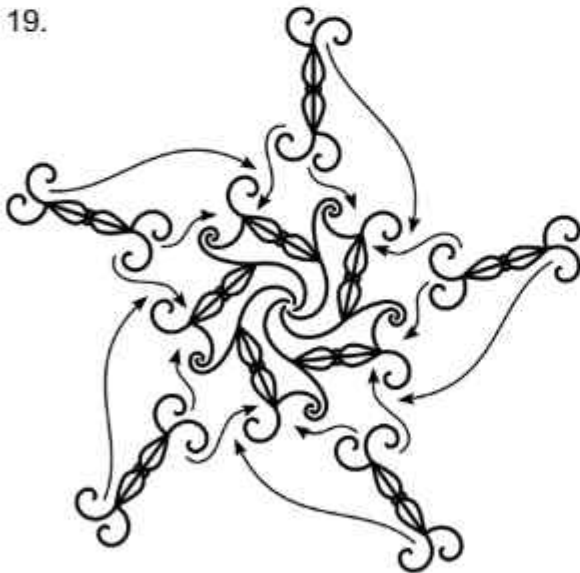

Add 5 new modules.

Add the left spiral into a vortex of two left spirals. Such a vortex of 3 spirals corresponds to a triangular face of the icosidodecahedron. Add the right spirals of the module to the two different loose spiral one at the left, one at the right. When you add the next module an open vortex of 3 spirals arise. It is an uncompleted pentagon that will be closed in the next step.

20.

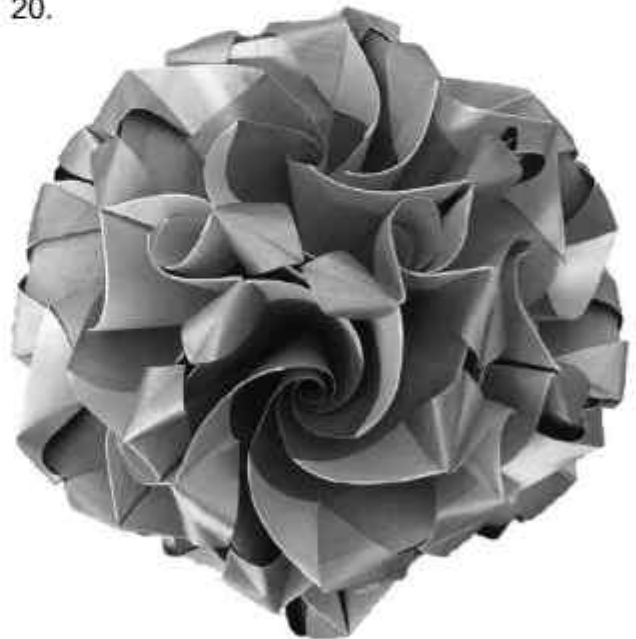

Continue closing pentagons and triangles in alternating steps until the model close completely.

Deca Star / Usman Rosyidhi

Indonesia
Diagram: Hadi Tahir
<http://www.instagram.com/letsfolding>
<https://youtube.com/om/hadhart>
Origami Harri Hadi

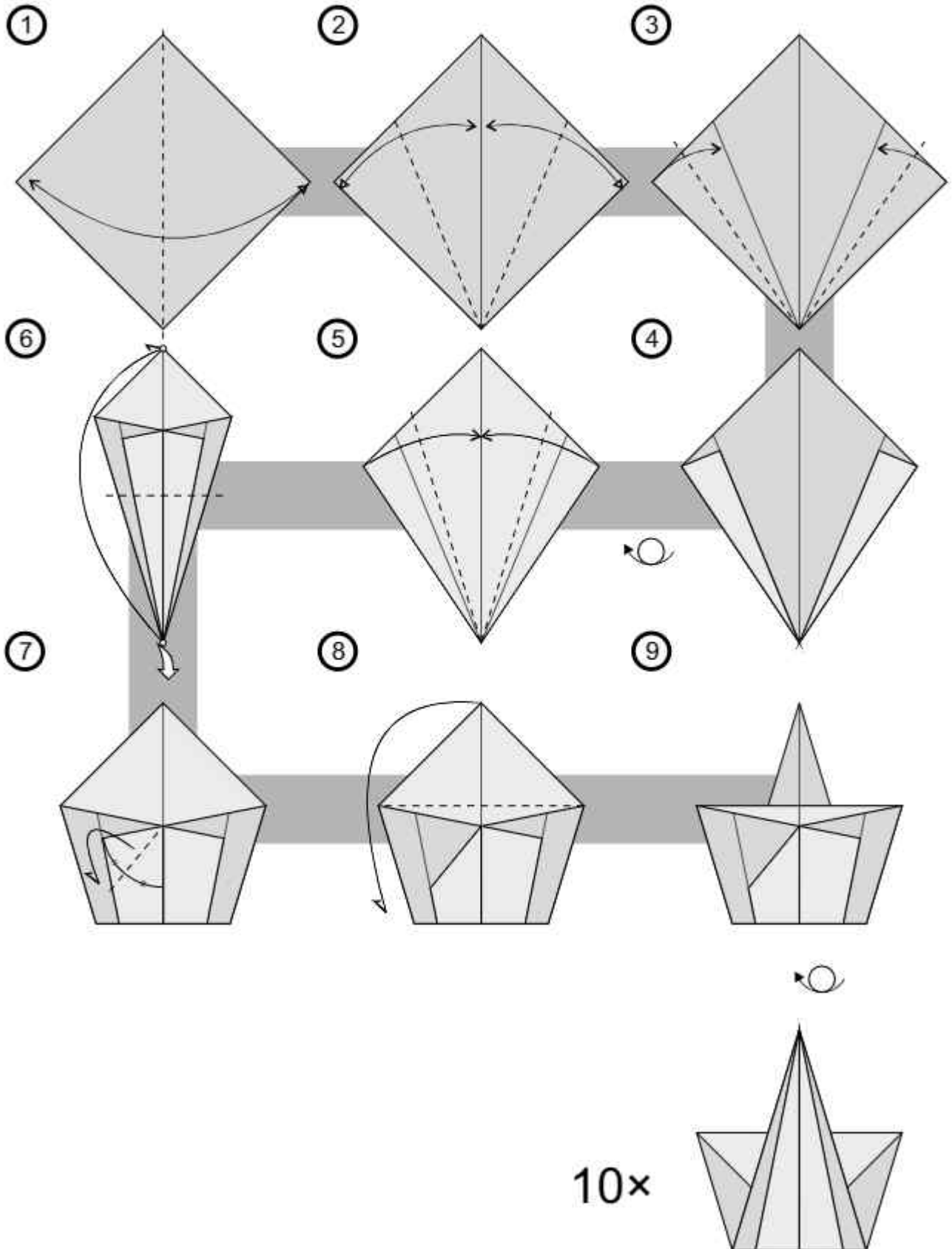

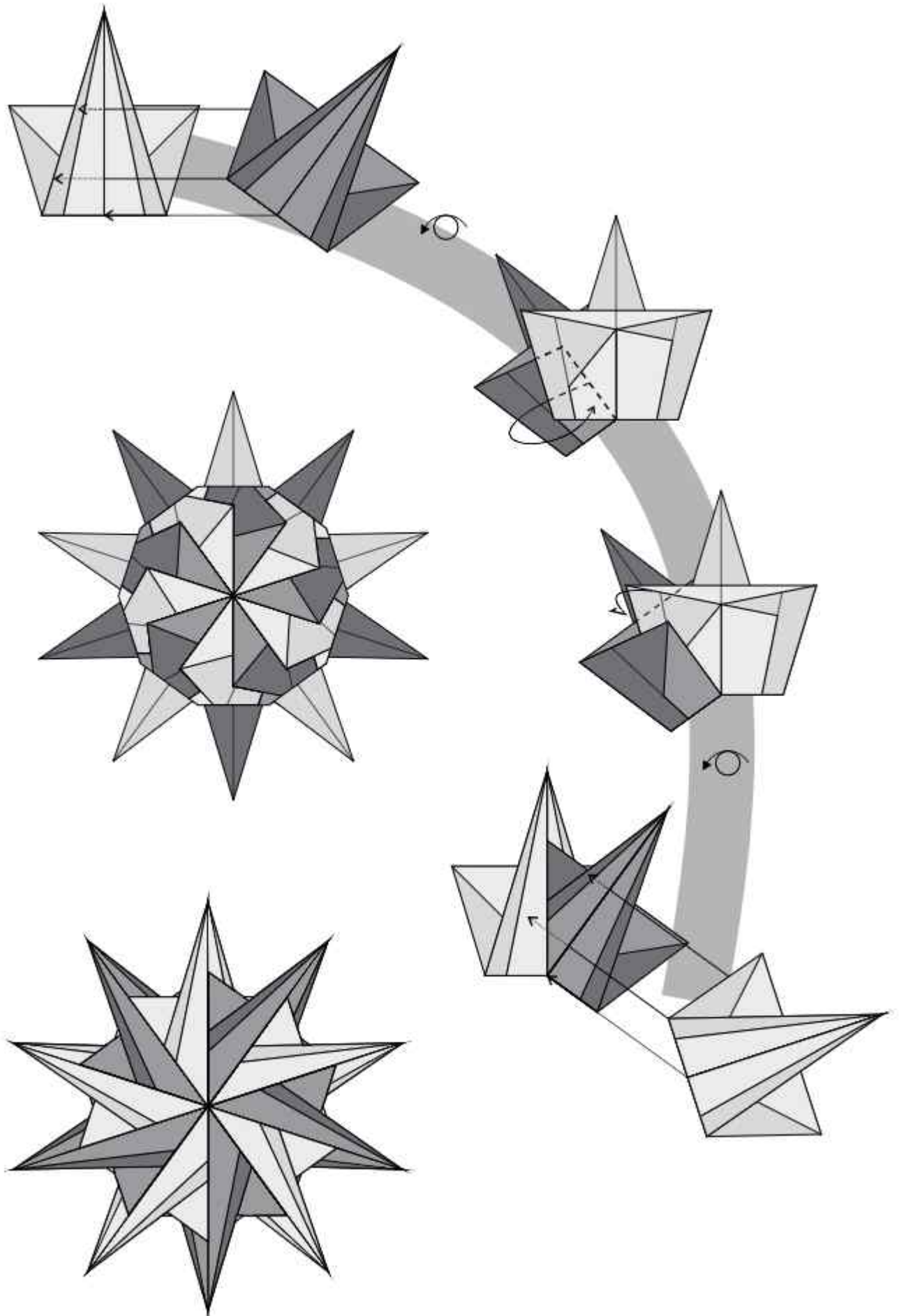

Tsuru de dos Cabezas / Allan Kenedy

País/country: Brasil/Brazil

Tamanho recomendado/Recommended size: 20cm x 20cm

Nível/level: ★★☆☆☆

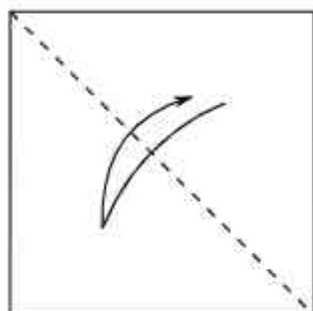

1. Lado branco para cima. Dobre a diagonal.
White side up. Fold the diagonal.

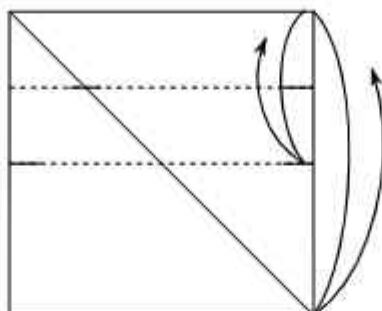

2. Faça marcas no papel como mostrado.
Make marks on the paper as shown.

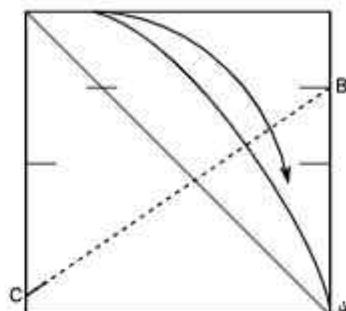

3. Traga o canto A para a borda superior com o vinco passando pela marca B, formando o ponto C.
Bring corner A to the top edge with the crease passing through mark B, forming point C.

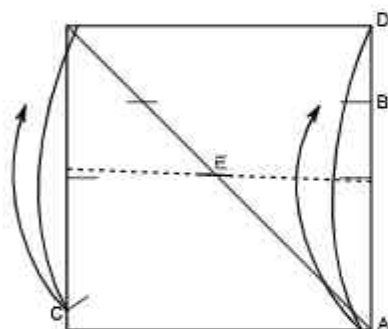

4. Traga a borda superior para o canto C e o canto D para a borda inferior, marcando o vinco intersectando a diagonal.
Bring the top edge to the corner C and the corner D to the bottom edge, marking the crease intersecting the diagonal.

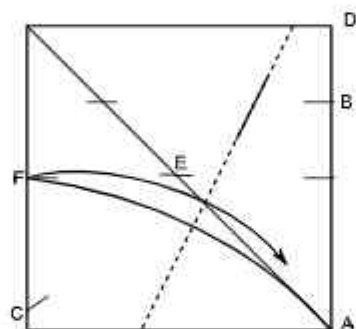

5. Dobre o canto A sobre a marca F formando o vinco mostrado.
Fold the corner A over mark F forming the crease shown.

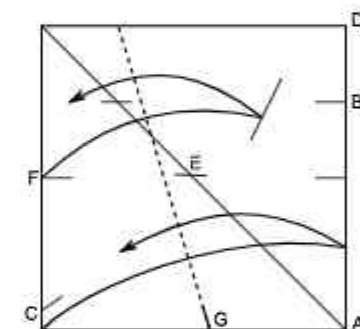

6. Traga o ponto F sobre a marca feita e o canto inferior esquerdo sobre a borda direita, marcando o ponto G.
Bring point F over the mark made and the lower left corner over the right edge, marking point G.

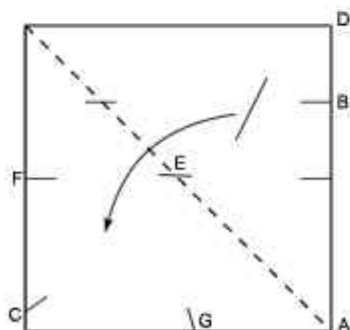

7. Dobre a diagonal.
Fold the diagonal.

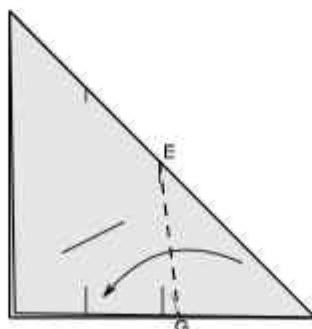

8. Dobre em vale conectando os pontos E e G.
Valley fold connecting points E and G.

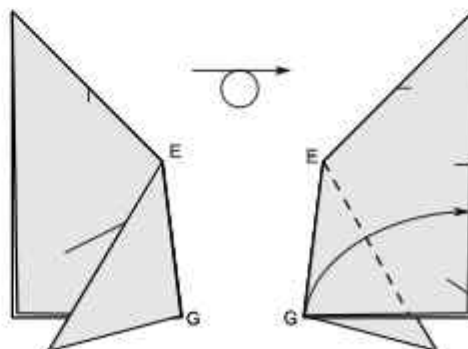

9. Vire.
Turn over.

10. Traga o ponto G sobre a borda direita com o vinco passando pelo ponto E.
Bring point G over the right edge with the crease going through point E.

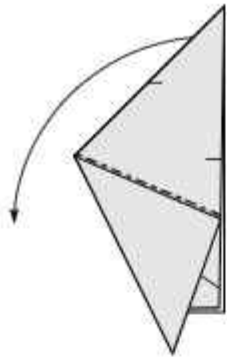

11. Dobre a aba para trás através da borda do papel.
Fold the flap back over the edge of the paper.

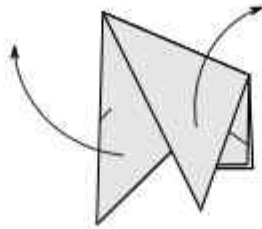

12. Desdobre tudo.
Unfold everything.

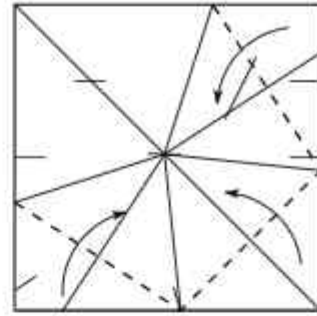

13. Dobre como mostrado.
Fold was shown.

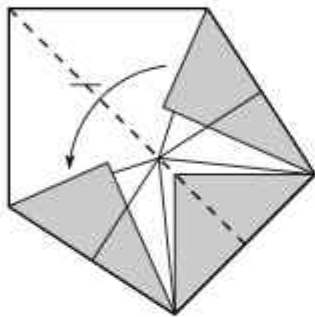

14. Dobre a diagonal.
Fold the diagonal.

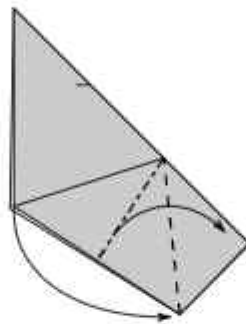

15. Dobre esmagando.
Squash fold.

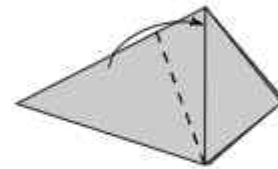

16. Dobre a marca existente sobre o vinco vertical.
Fold the existing mark over the vertical crease.

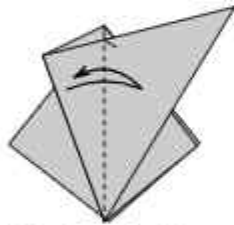

17. Dobre e desdobre.
Fold and unfold.

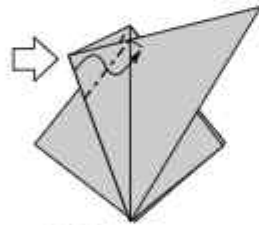

18. Dobra reversa.
Reverse fold.

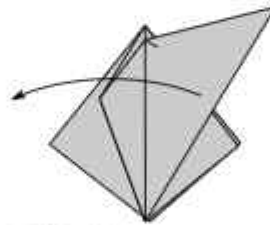

19. Desdobre para o passo 16.
Unfold to step 16.

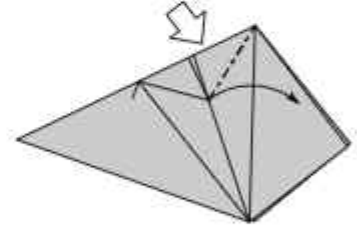

20. Dobre esmagando.
Squash fold.

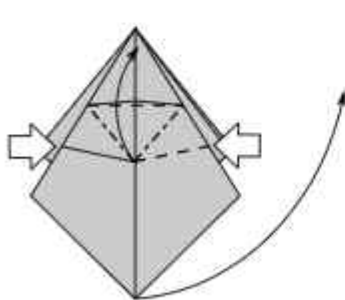

21. Dobre como mostrado.
Fold was shown.

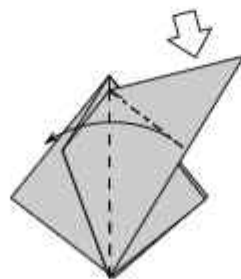

22. Dobre esmagando.
Squash fold.

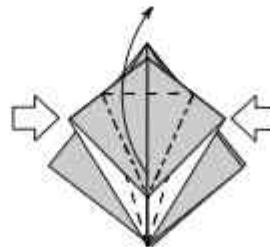

23. Dobra pétala.
Petal fold.

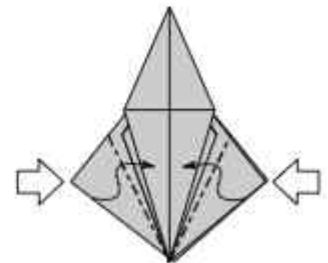

24. Dobras reversas.
Reverse folds.

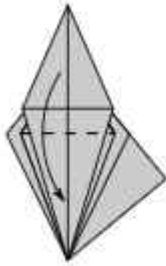

25. Dobre duas abas para baixo.
Fold two flaps down.



26. Vire.
Turn over.

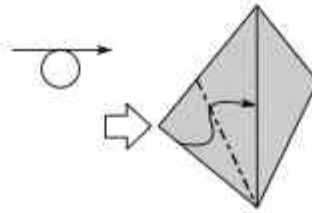

27. Dobre reversa.
Reverse fold.



28. Dobre e desdobre.
Fold and unfold.

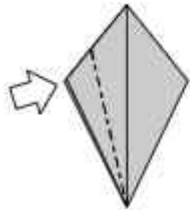

29. Afunde aberto.
Open sink.

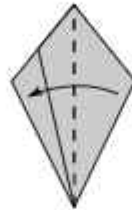

30. Dobre uma aba para a esquerda.
Fold one flap to the left.



31. Dobre uma aba para cima.
Fold one flap up.

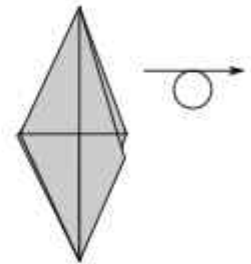

32. Vire.
Turn over.

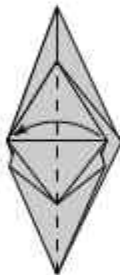

33. Dobre uma aba para a esquerda.
Fold one flap to the left.

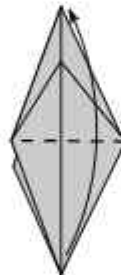

34. Dobre uma aba para cima.
Fold one flap up.

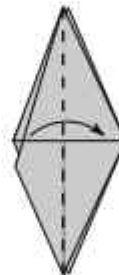

35. Dobre uma aba para a direita.
Fold one flap to the right.

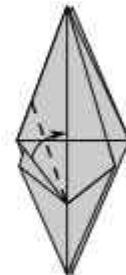

36. Dobre uma aba para o meio.
Fold one flap to the middle.



37. Dobre uma aba para a esquerda.
Fold one flap to the left.



38. Dobre as abas para o meio.
Fold the flaps to the middle.



39. Repita os passos 35-38 atrás.
Repeat the steps 35-38 behind.

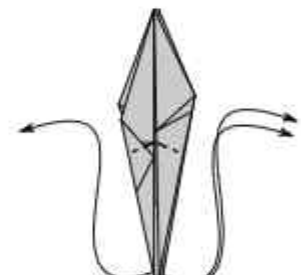

40. Faça dobras reversas.
Make reverse folds.

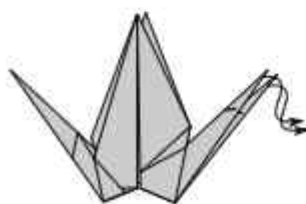

41. Faça dobras reversas.
Make reverse folds.



42. Modelo finalizado.
Finished model.

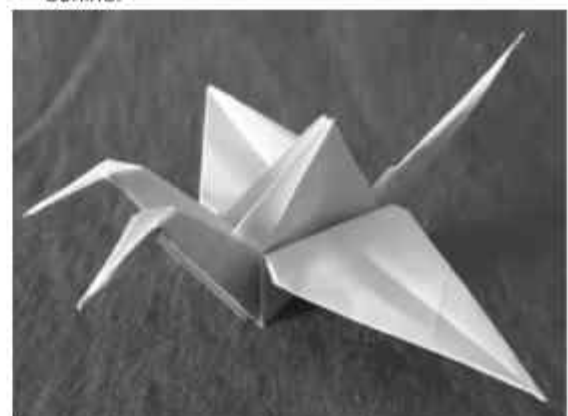

Sun Star / Enrica Dray

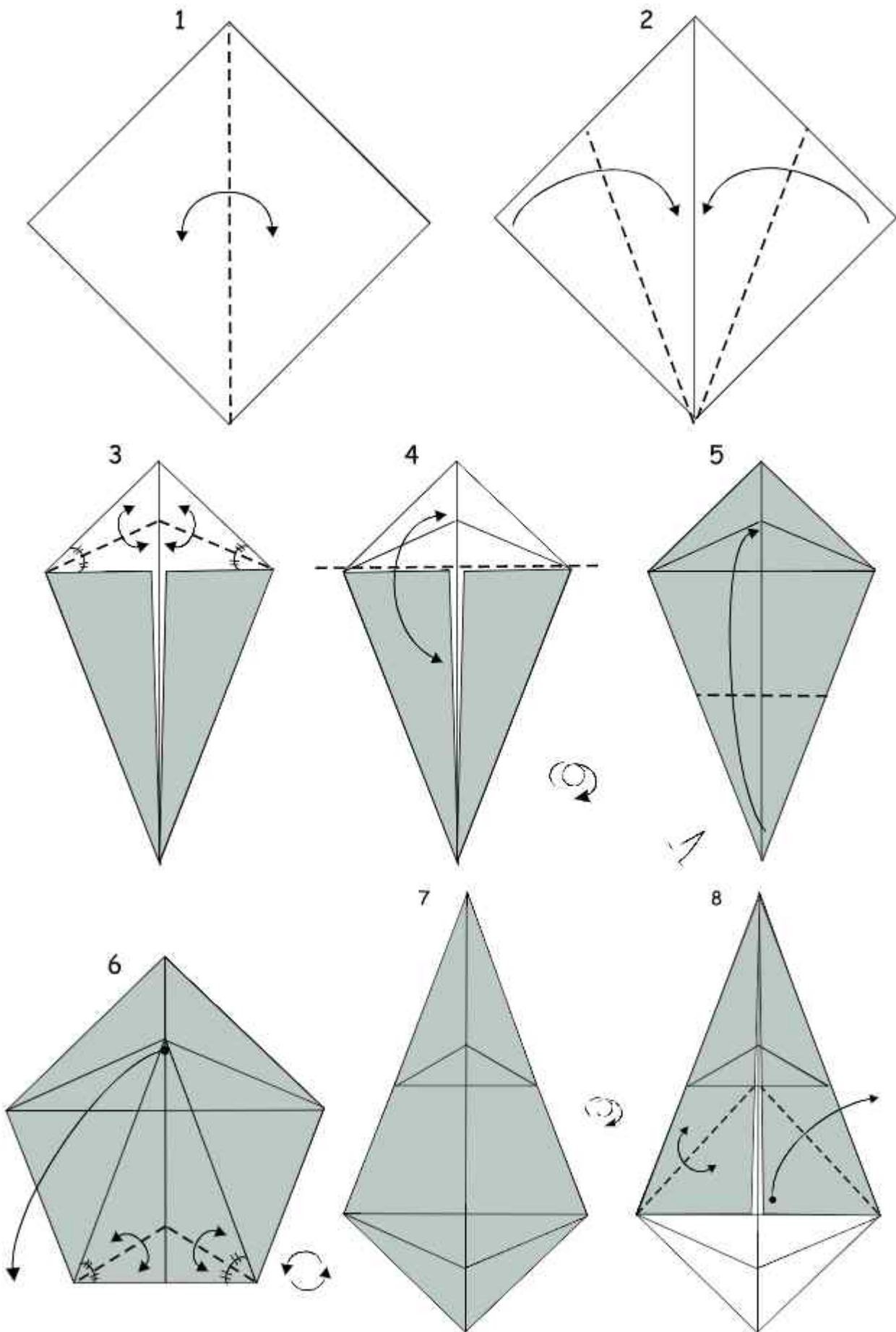

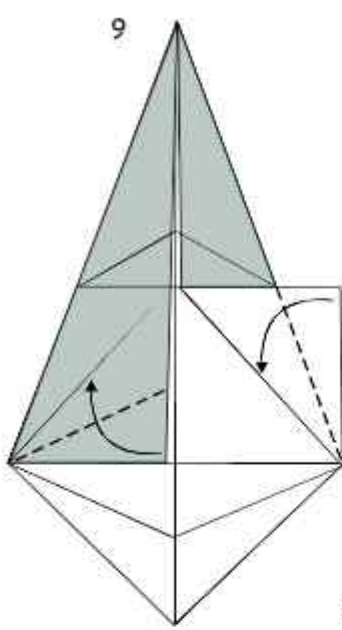

Chiudere

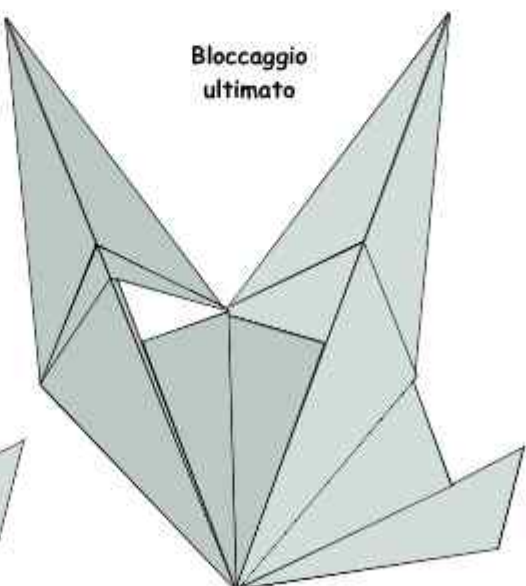
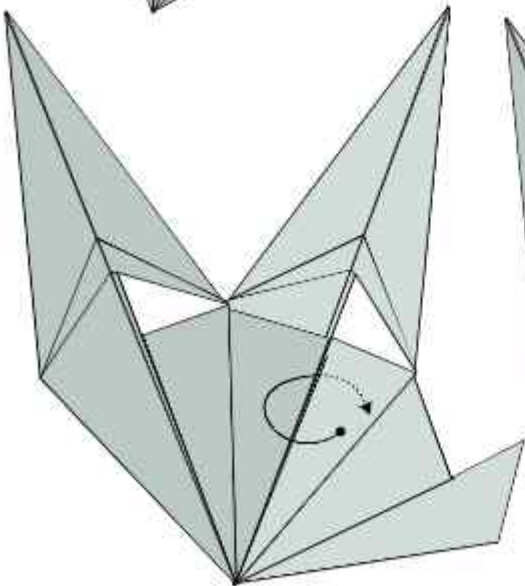
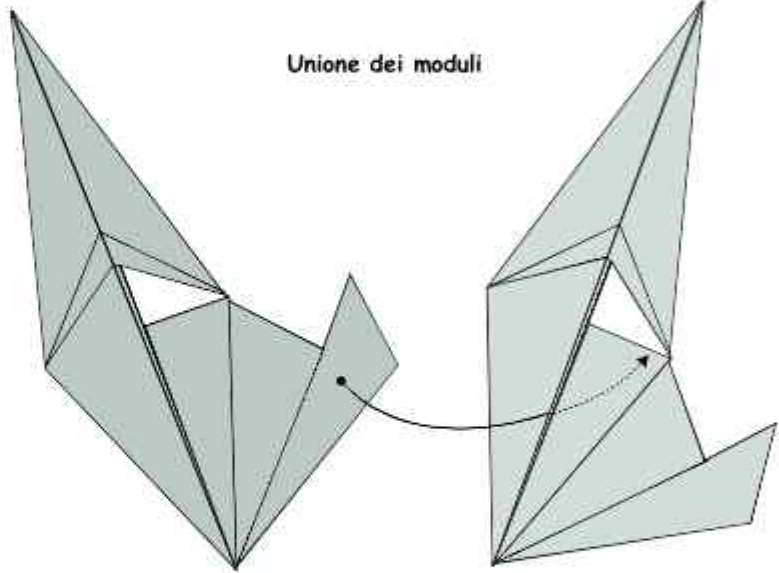
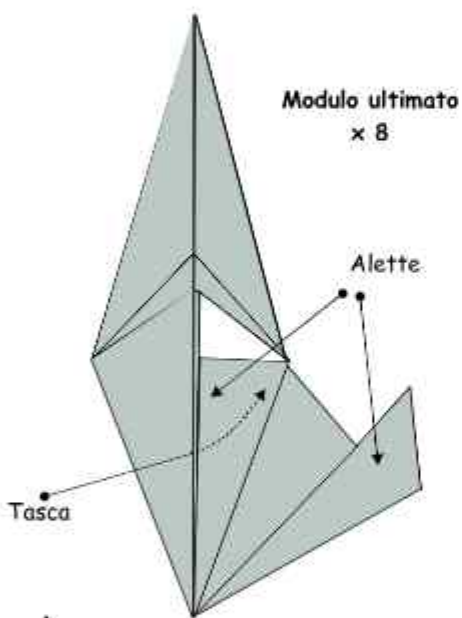
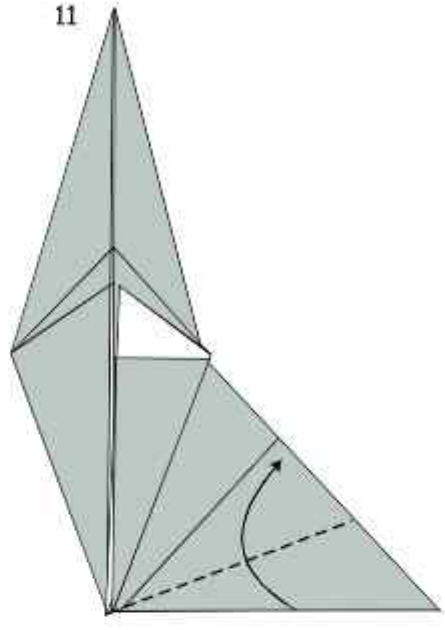
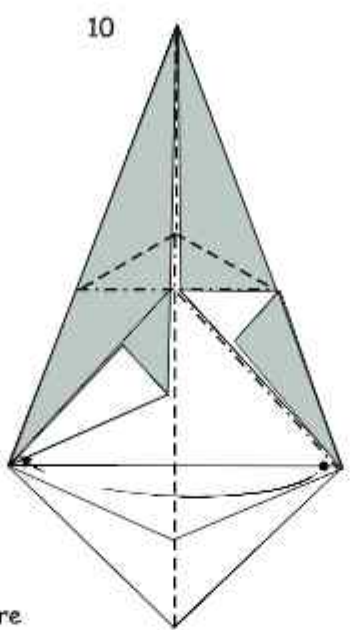

Majo Star / Jonicley Macedo

Diagramação: Jonicley Macedo.

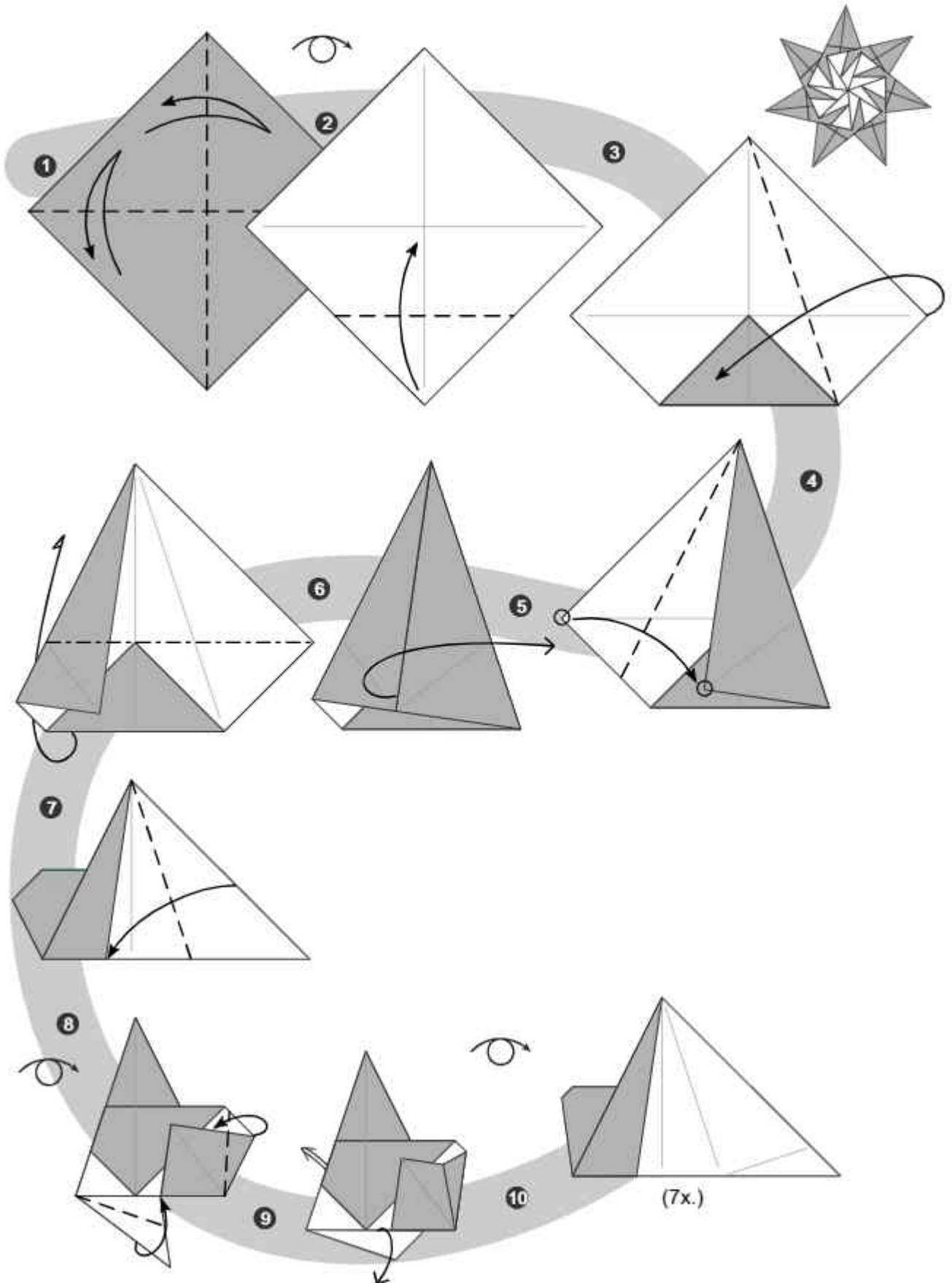

Montagem:

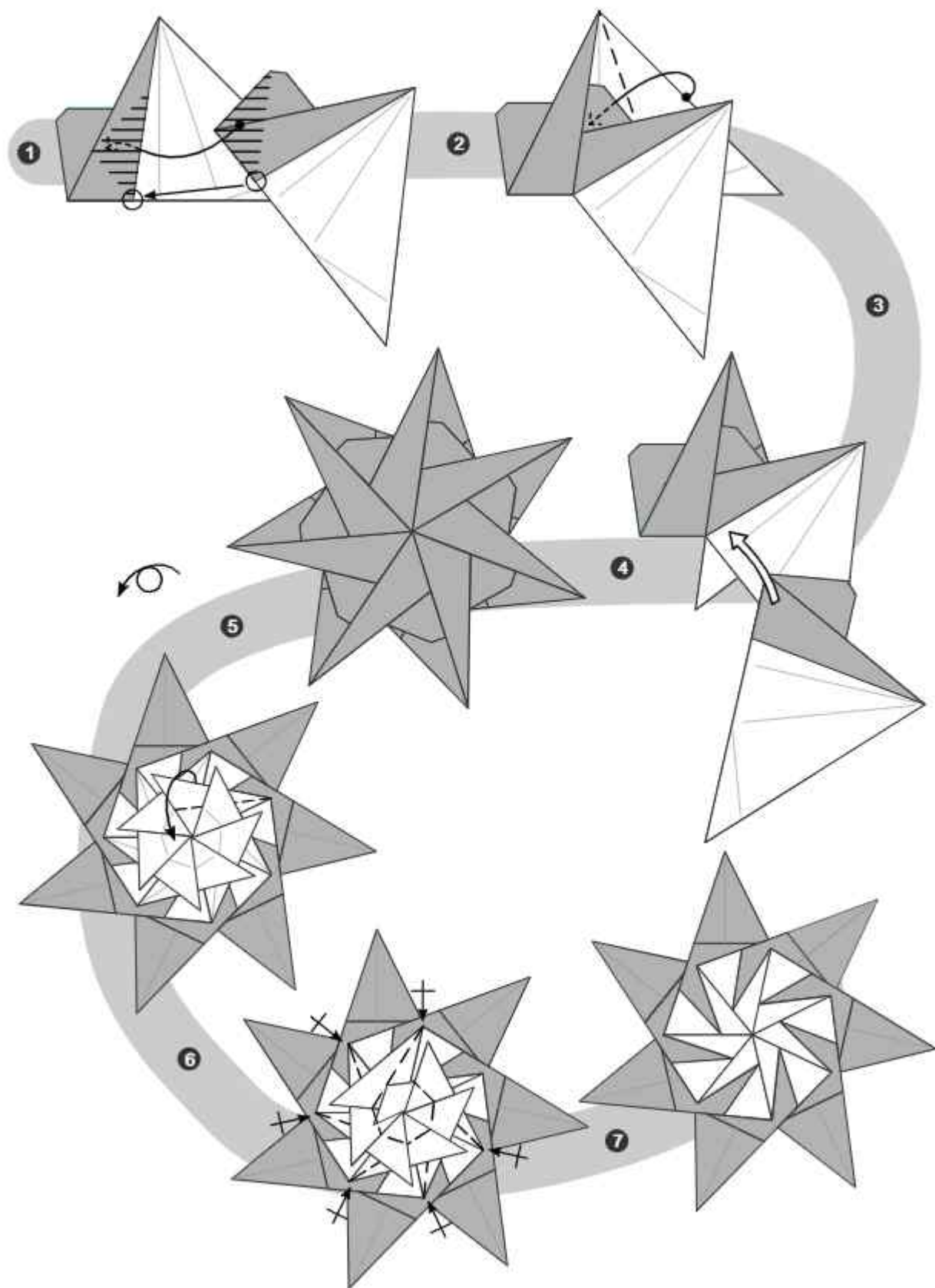

Stella Frattale / Francesco Decio

Preparazione del Modulo A
o comunque del foglio per il
giro ESTERNO

1

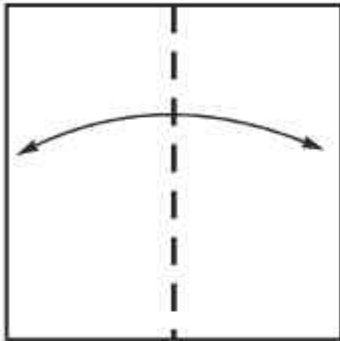

2

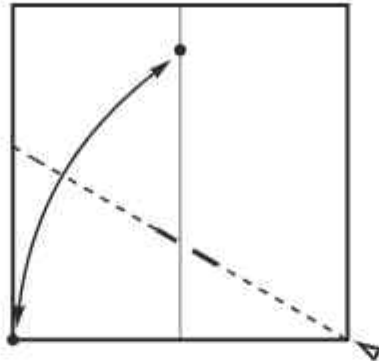

3

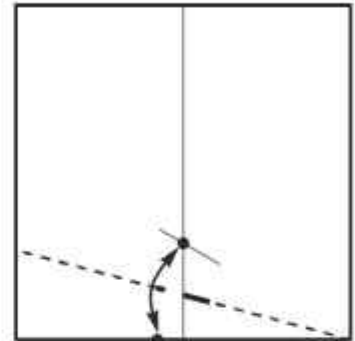

4

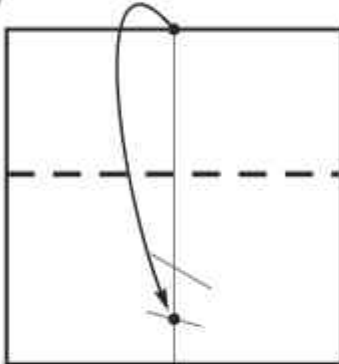

5

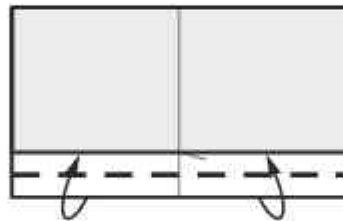

6

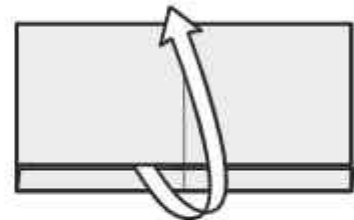

7

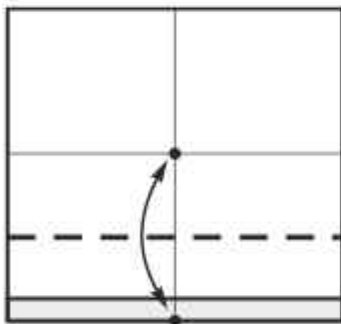

8

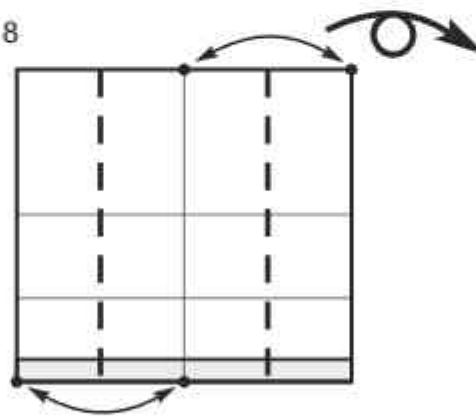

9

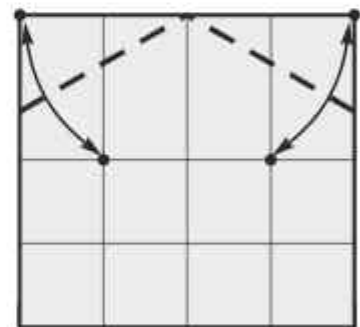

10

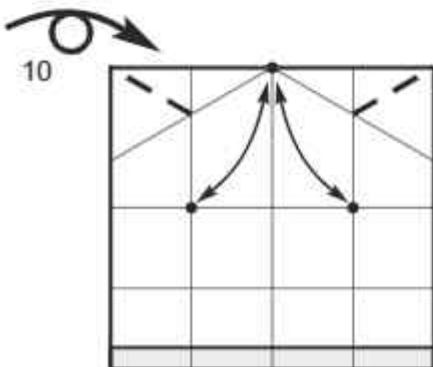

11

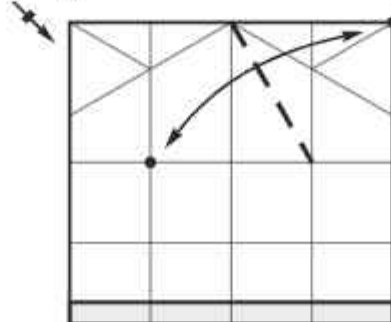

12

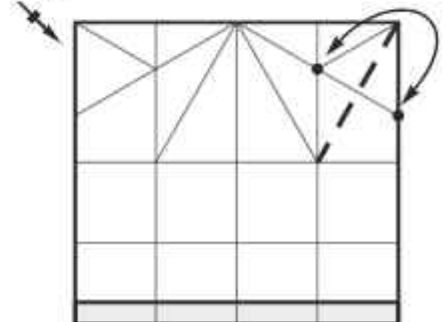

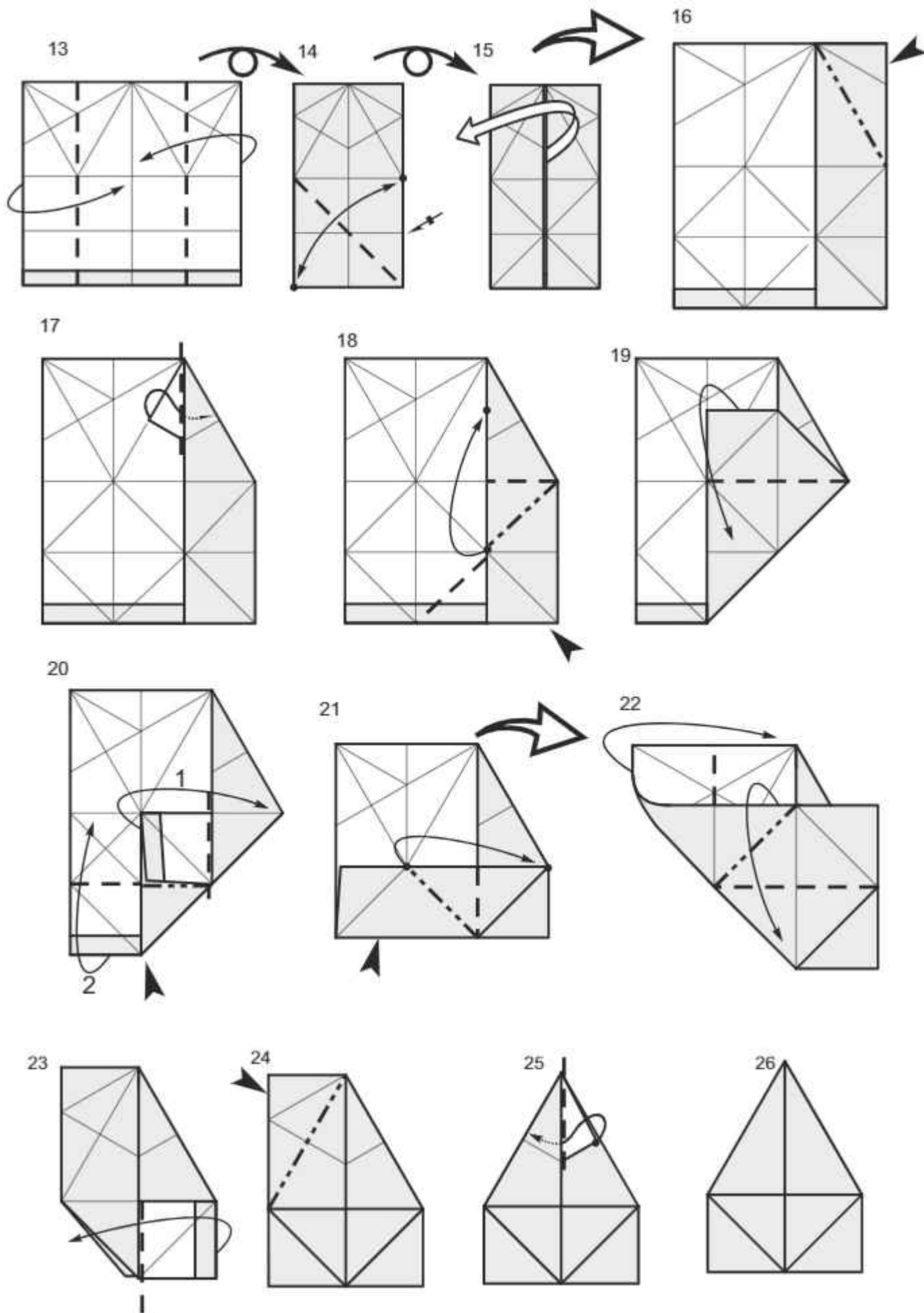

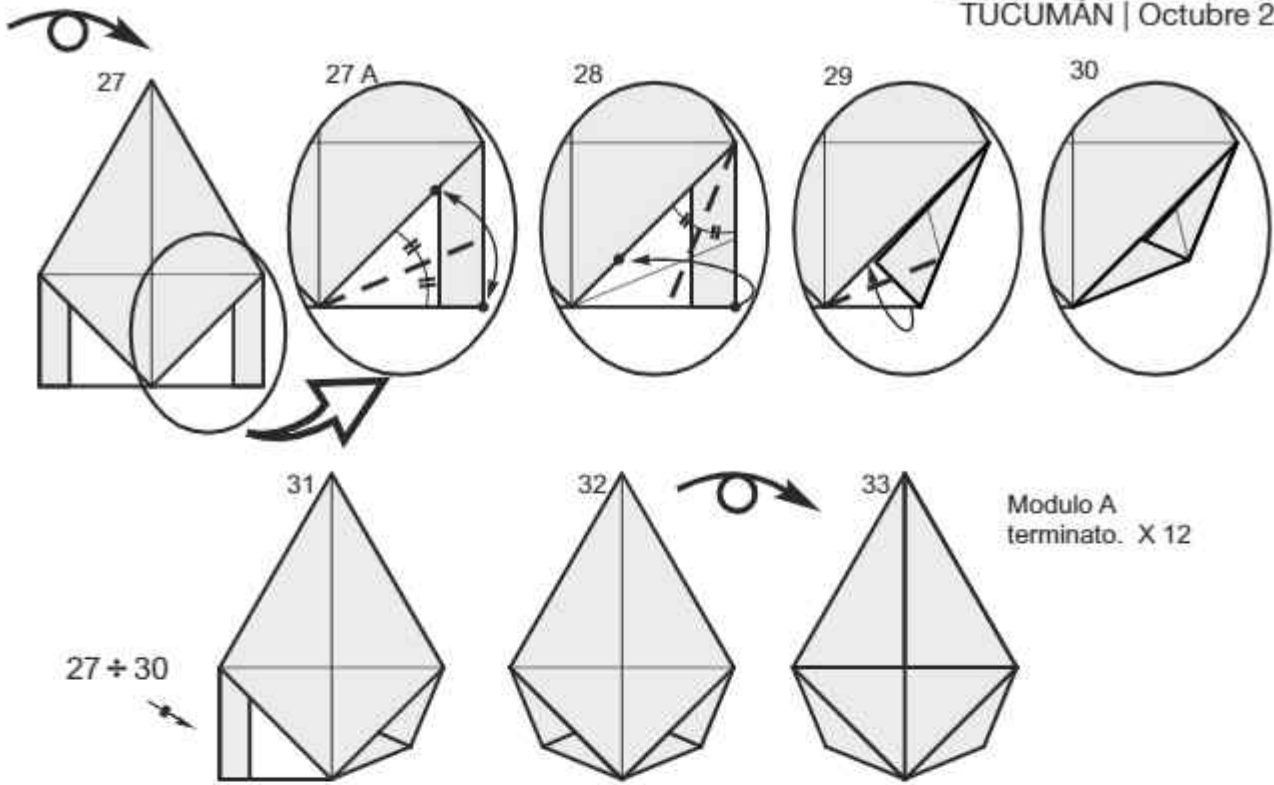

Preparazione foglio x modulo B

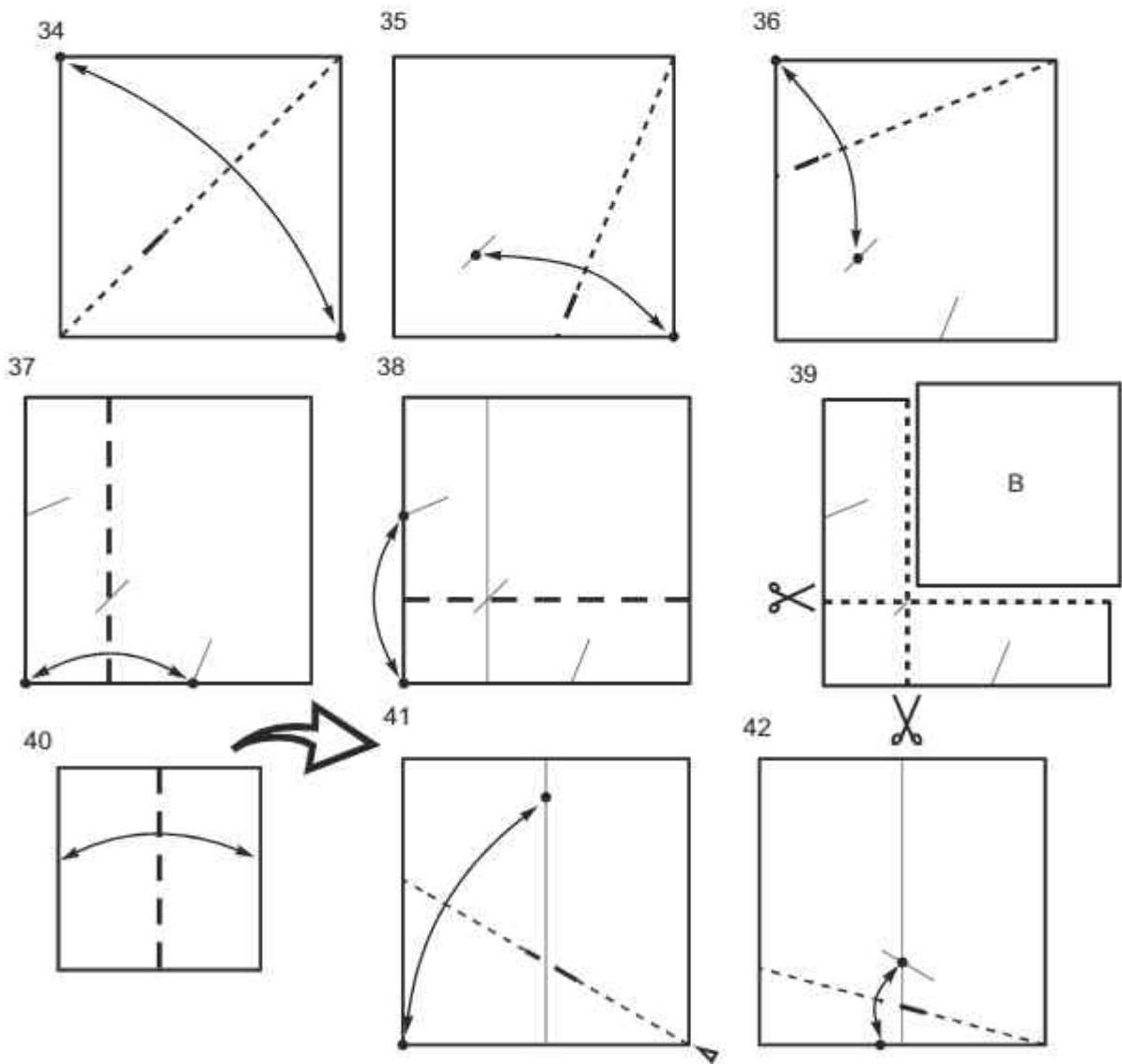

43

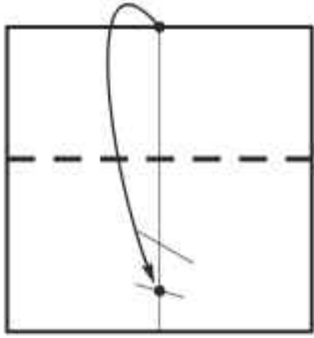

44

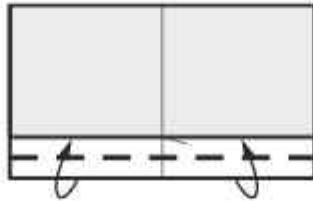

45

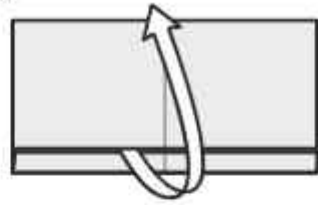

46

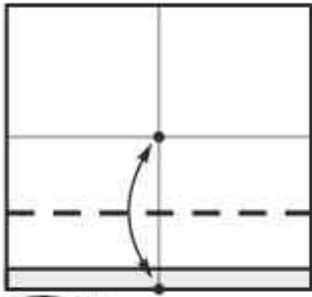

47

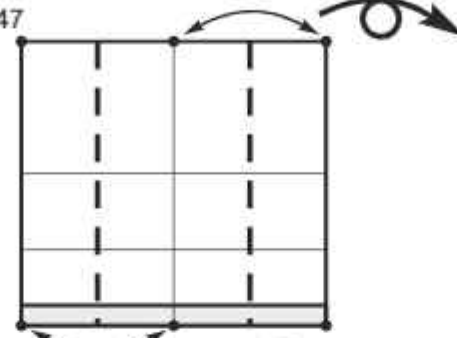

48

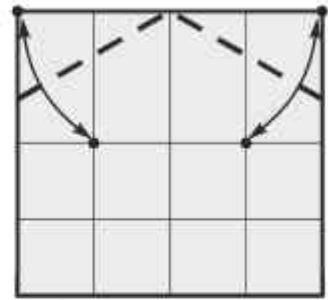

49

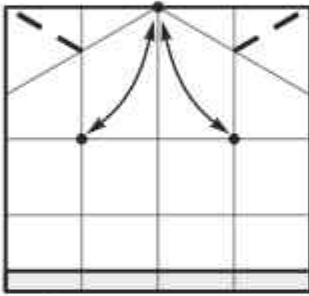

50

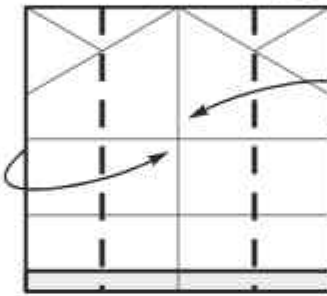

51

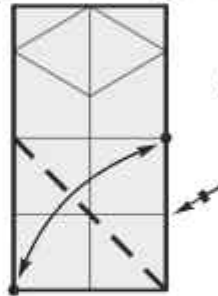

52

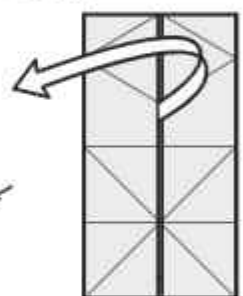

53

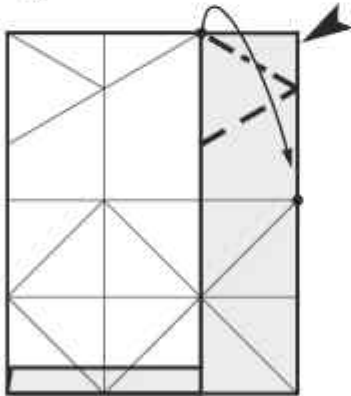

54

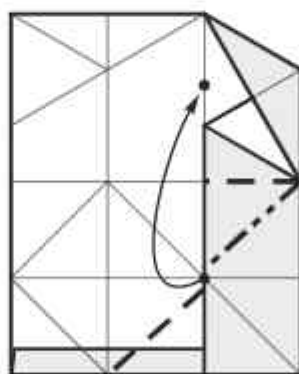

55

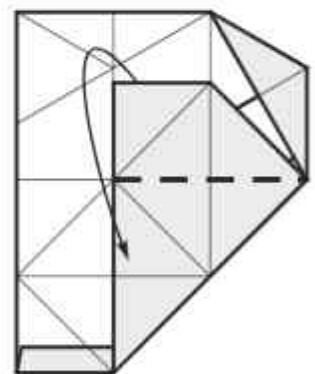

56

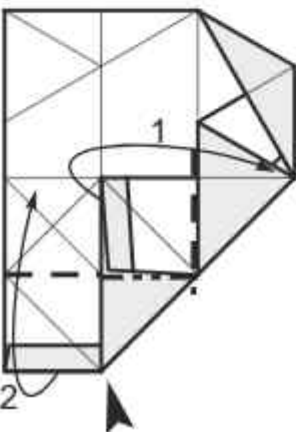

57

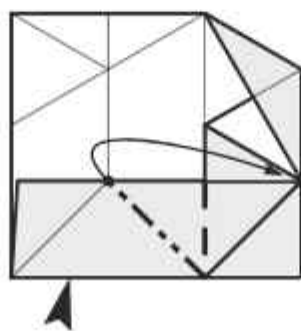

58

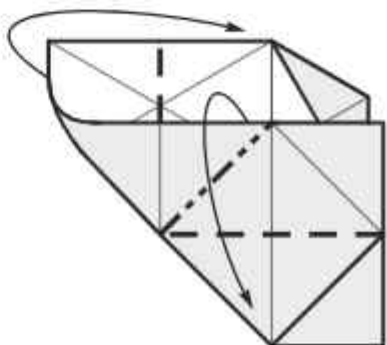

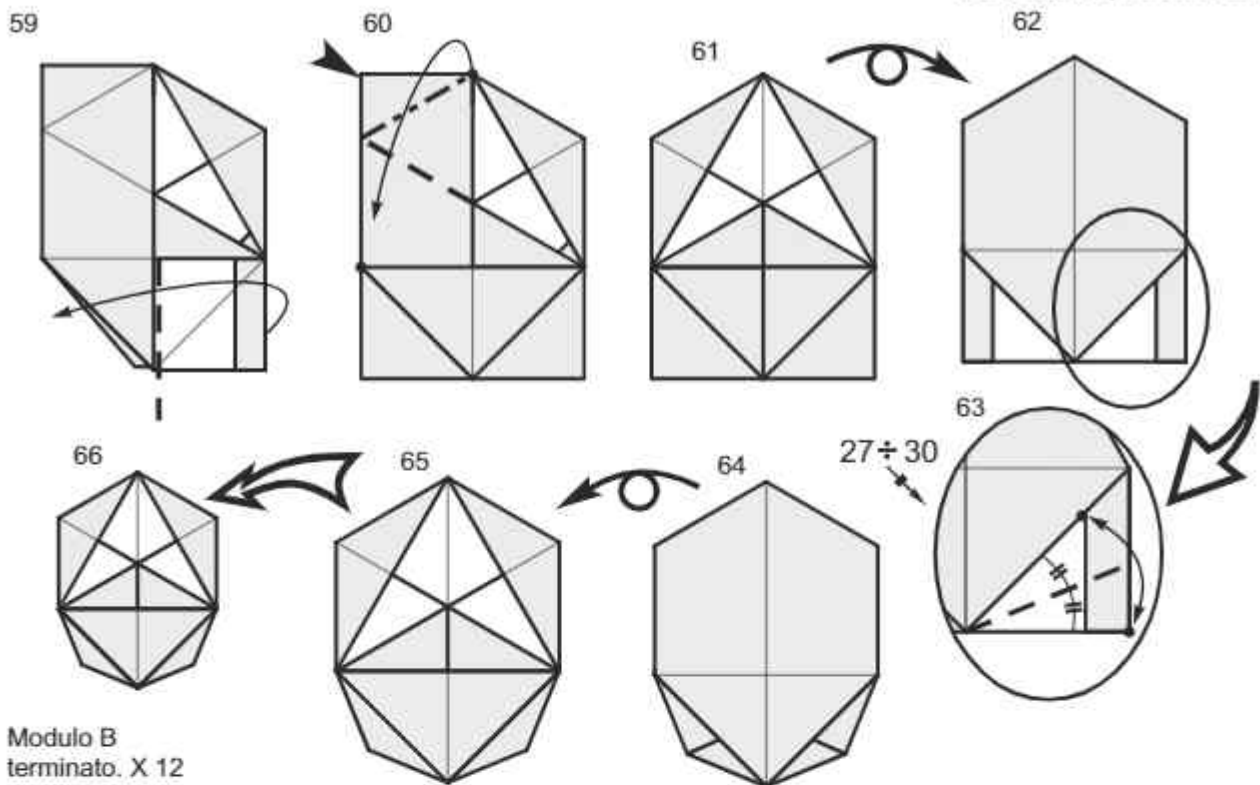

Modulo B
terminato. X 12

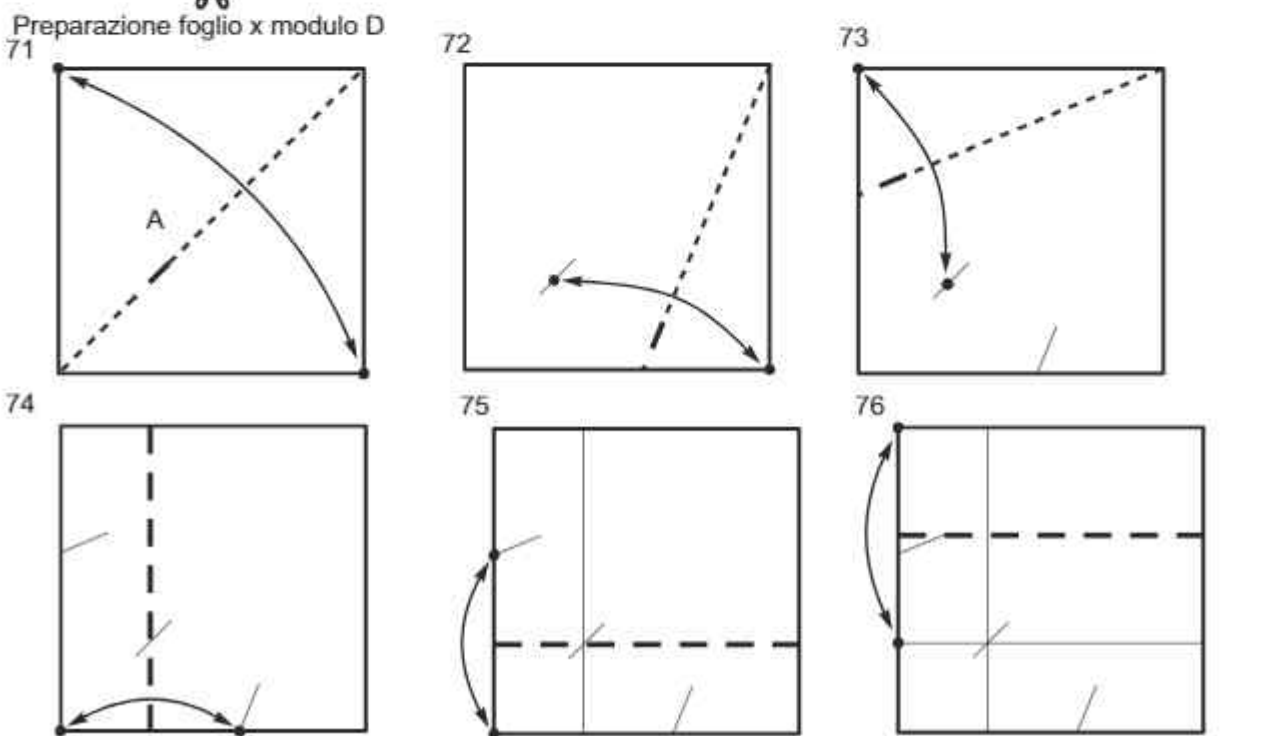
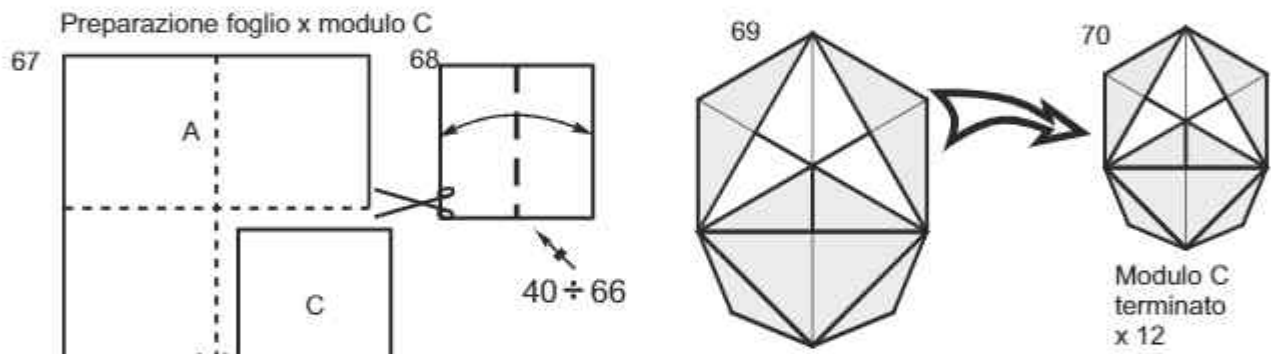

77

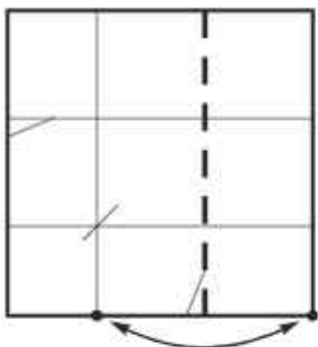

78

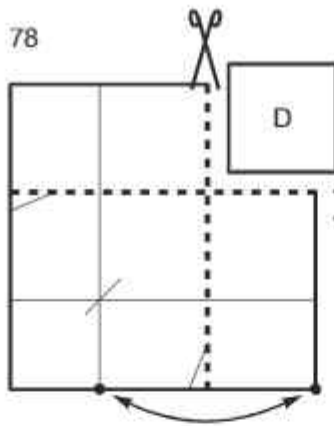

79

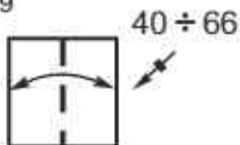

80

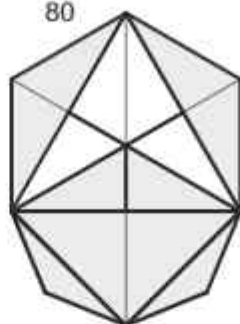

81

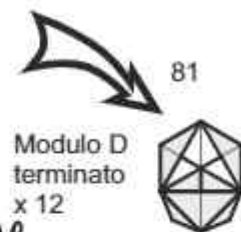

Preparazione foglio x modulo E
o comunque in ogni caso per il
modulo dell'ultimo giro interno

Modulo D
terminato
x 12

82

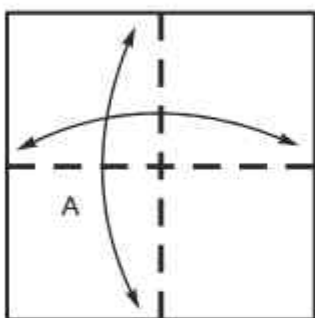

83

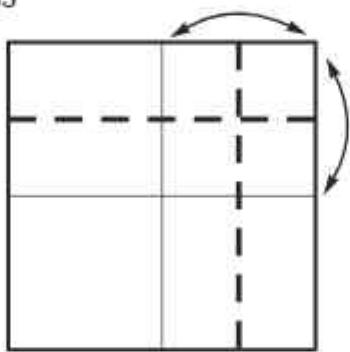

84

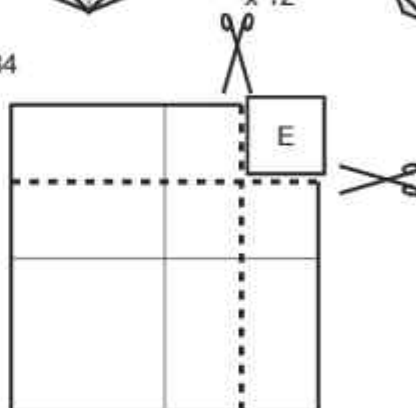

86

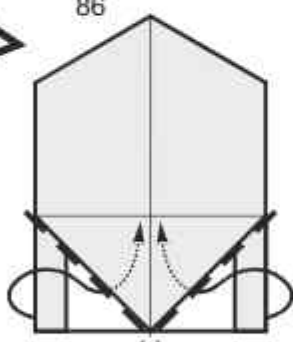

87

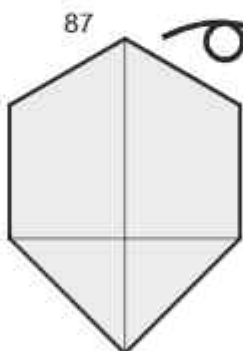

88

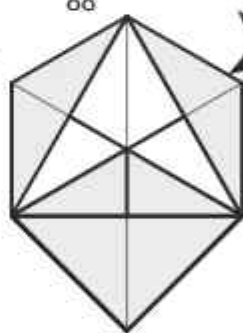

89

Modulo E
terminato
x 12

85



40 ÷ 62

Assemblaggio dei moduli

Modulo A

Modulo B

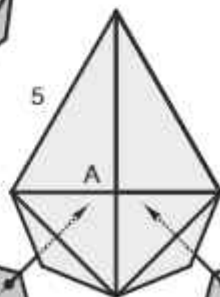
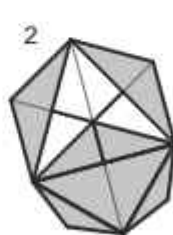

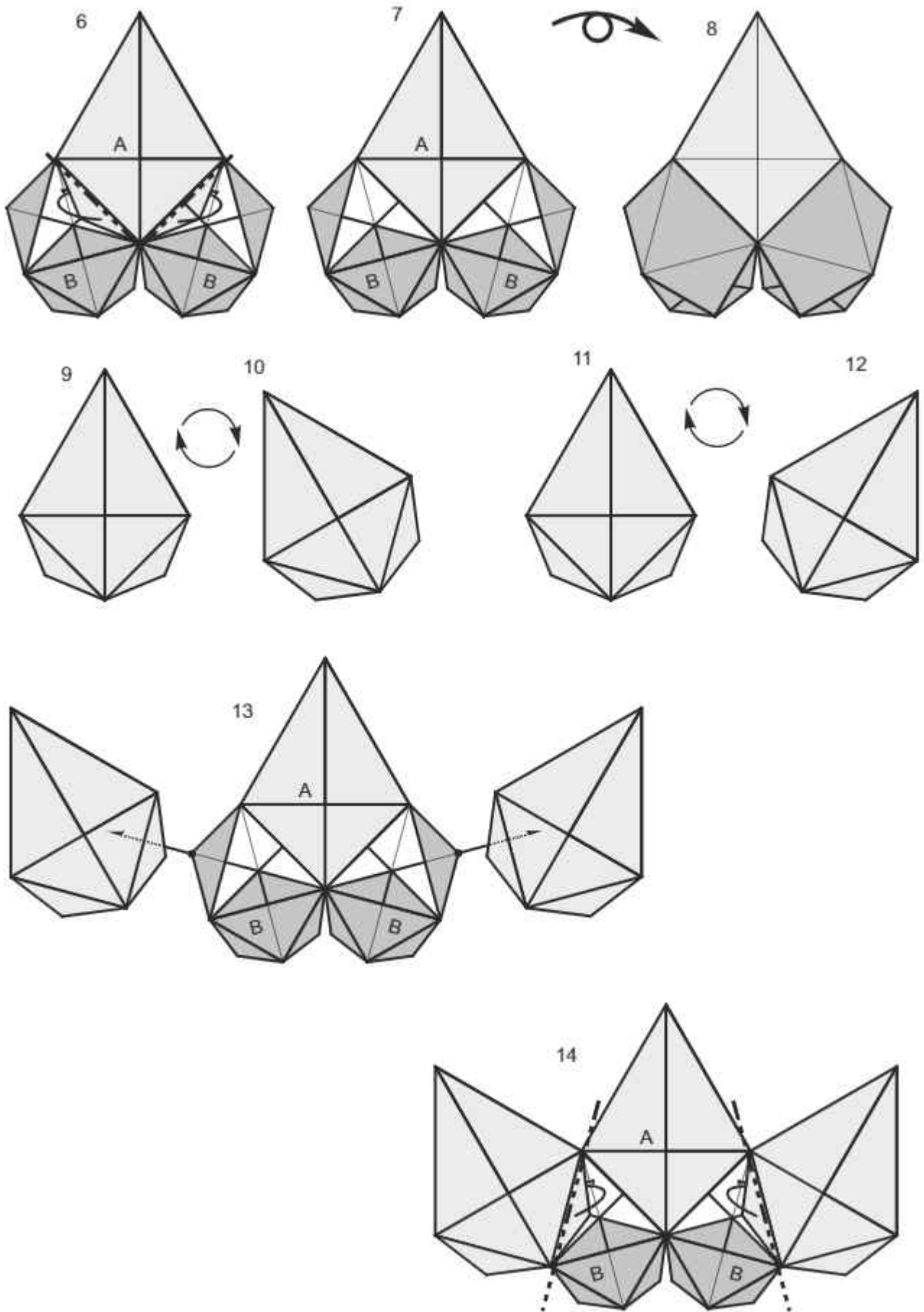

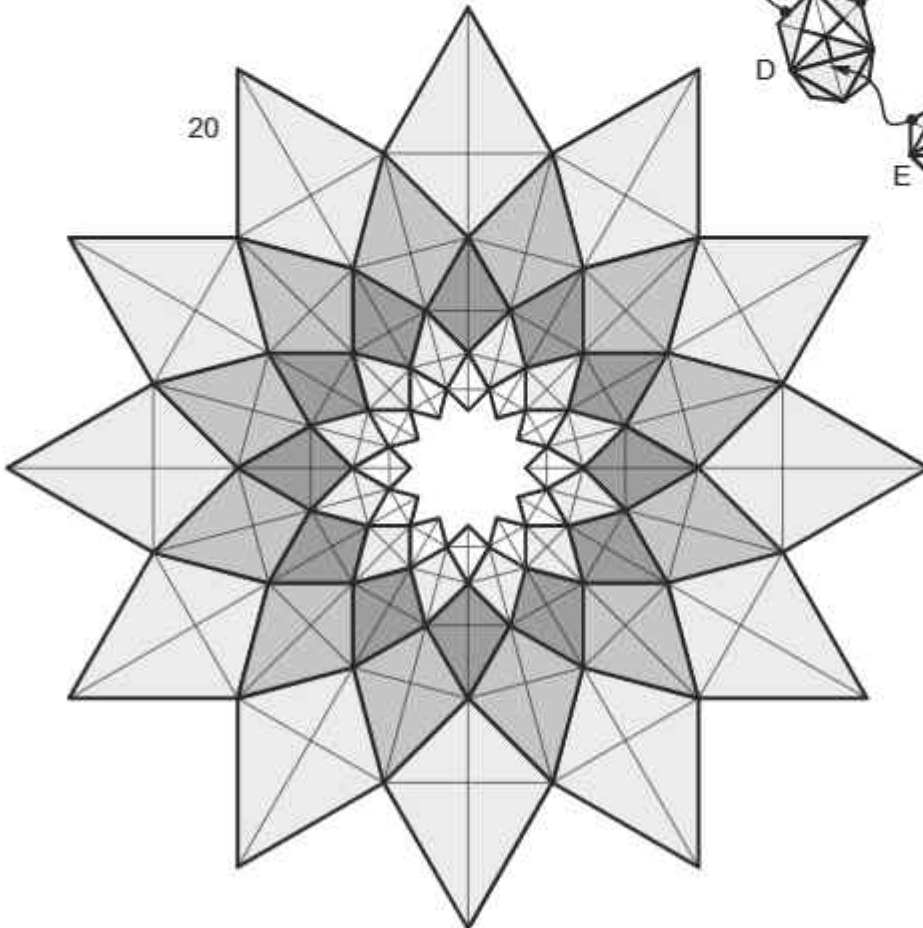
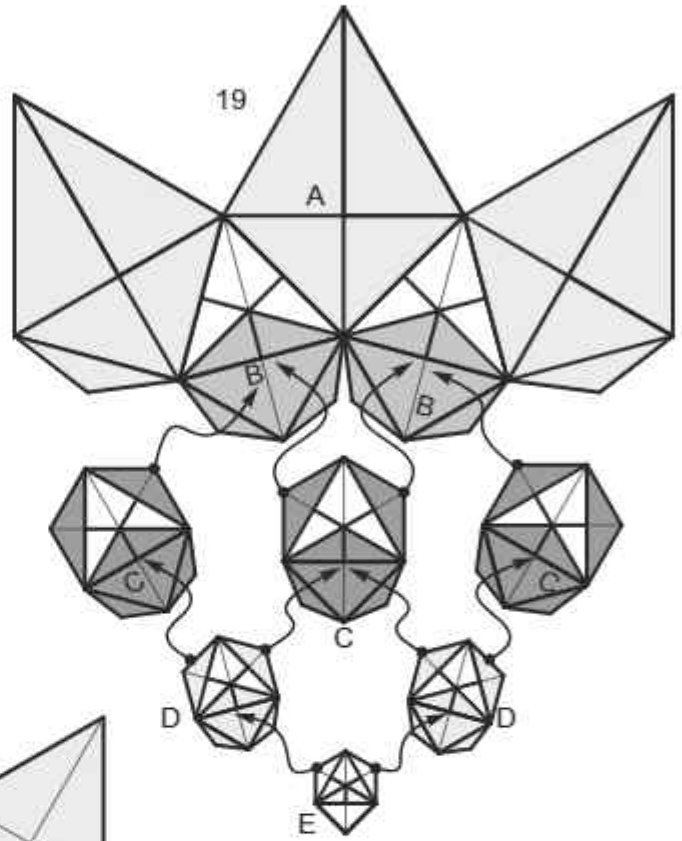
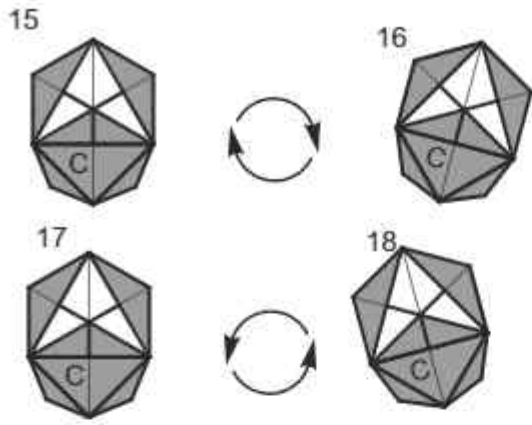

La stella frattale
terminata

Clic Clac / Paolo Bascetta

Diagrama: Francesco Decio

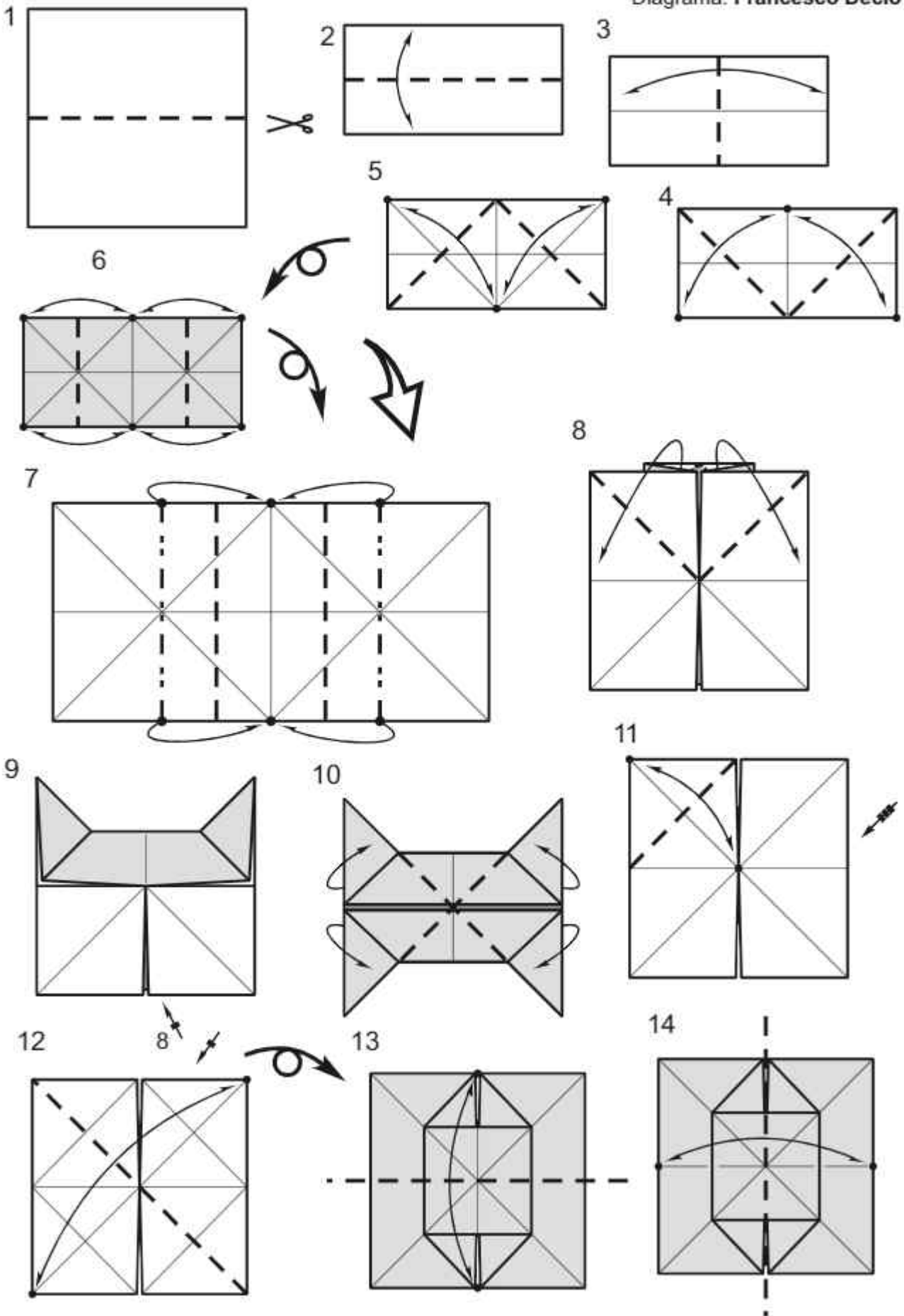

15

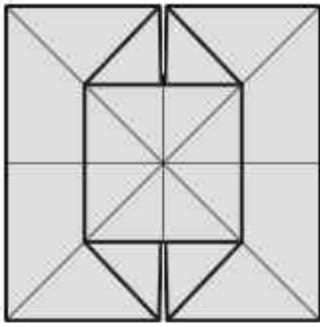

Modulo
finito
X 4

Montaggio
moduli
del clic clac

1

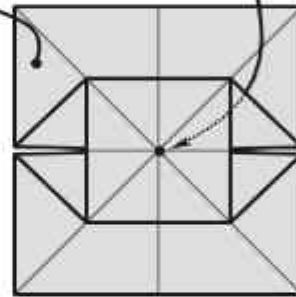
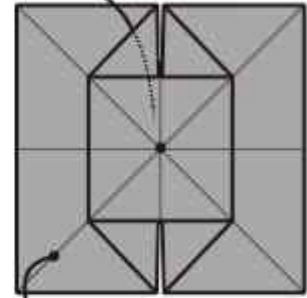
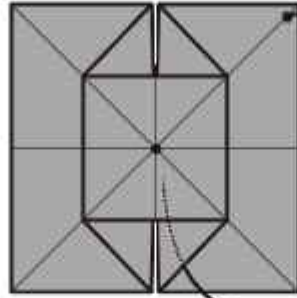
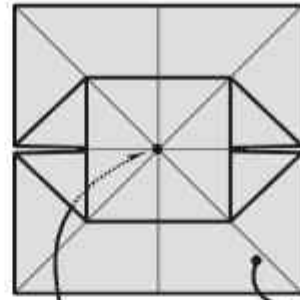

2

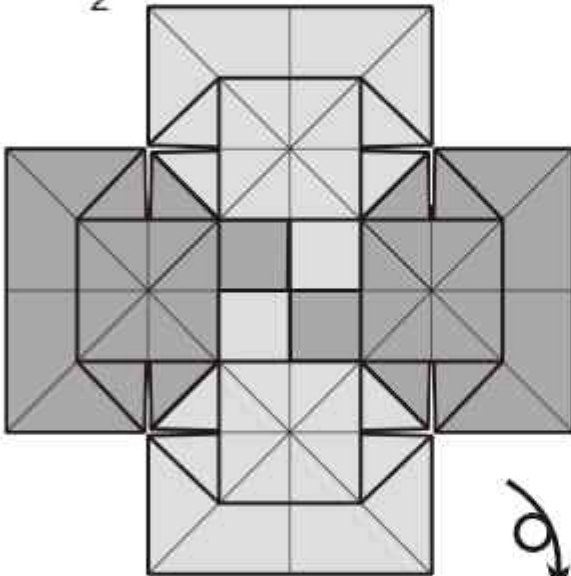

3

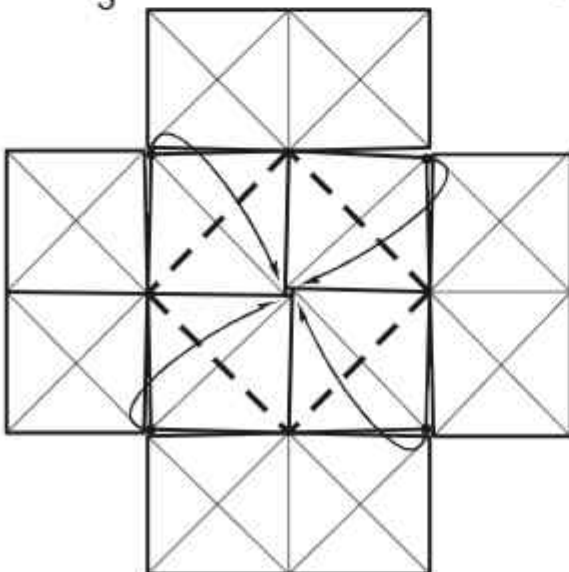

4

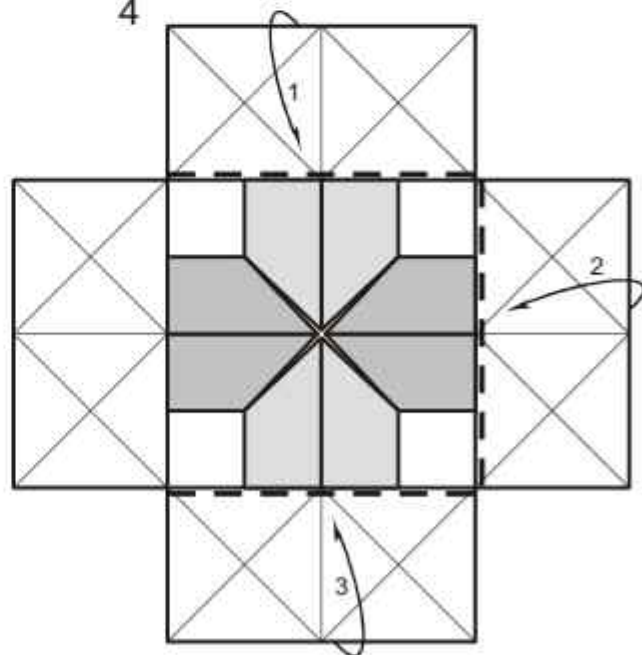

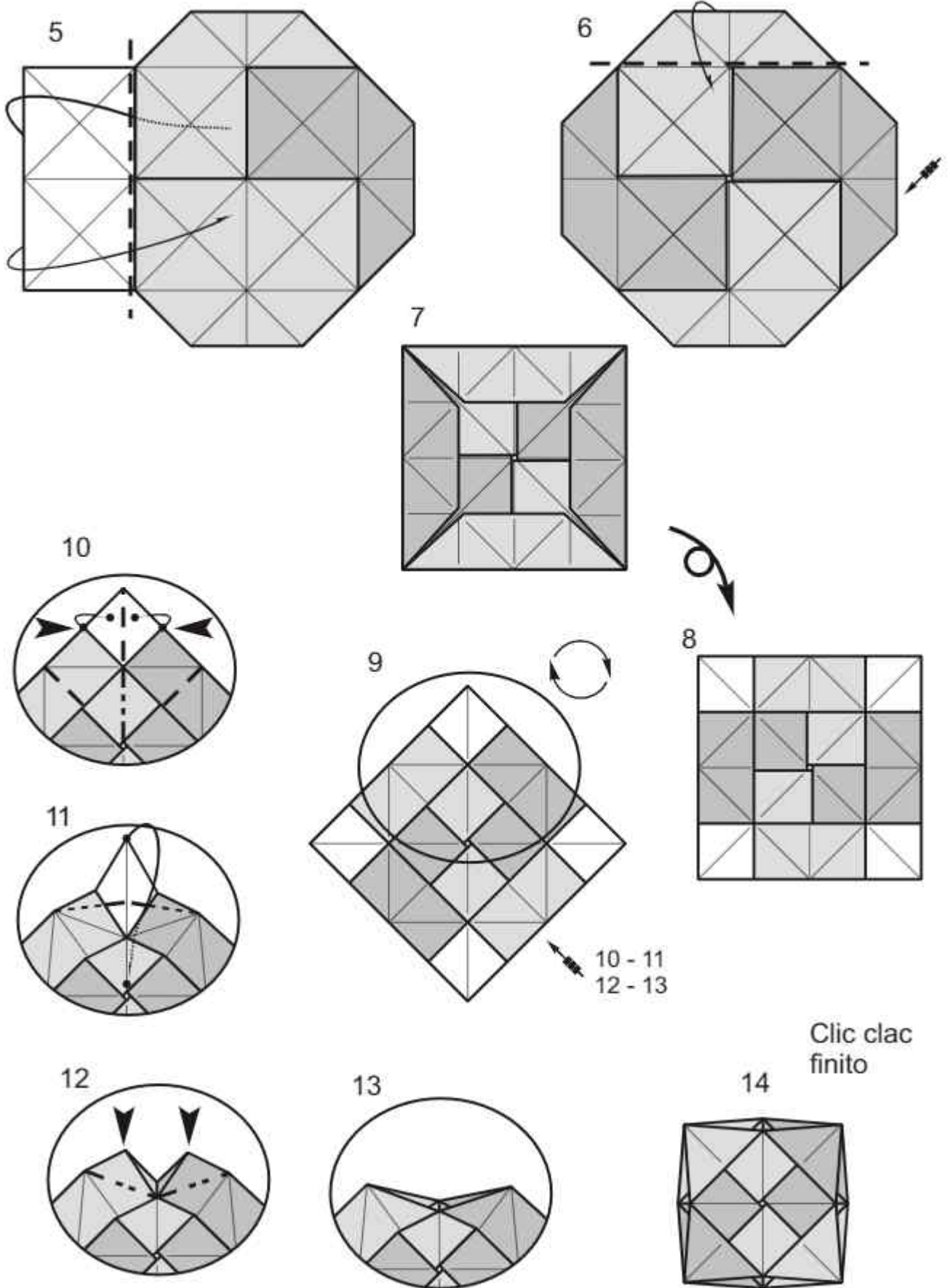

Per giocare con il clic clac:

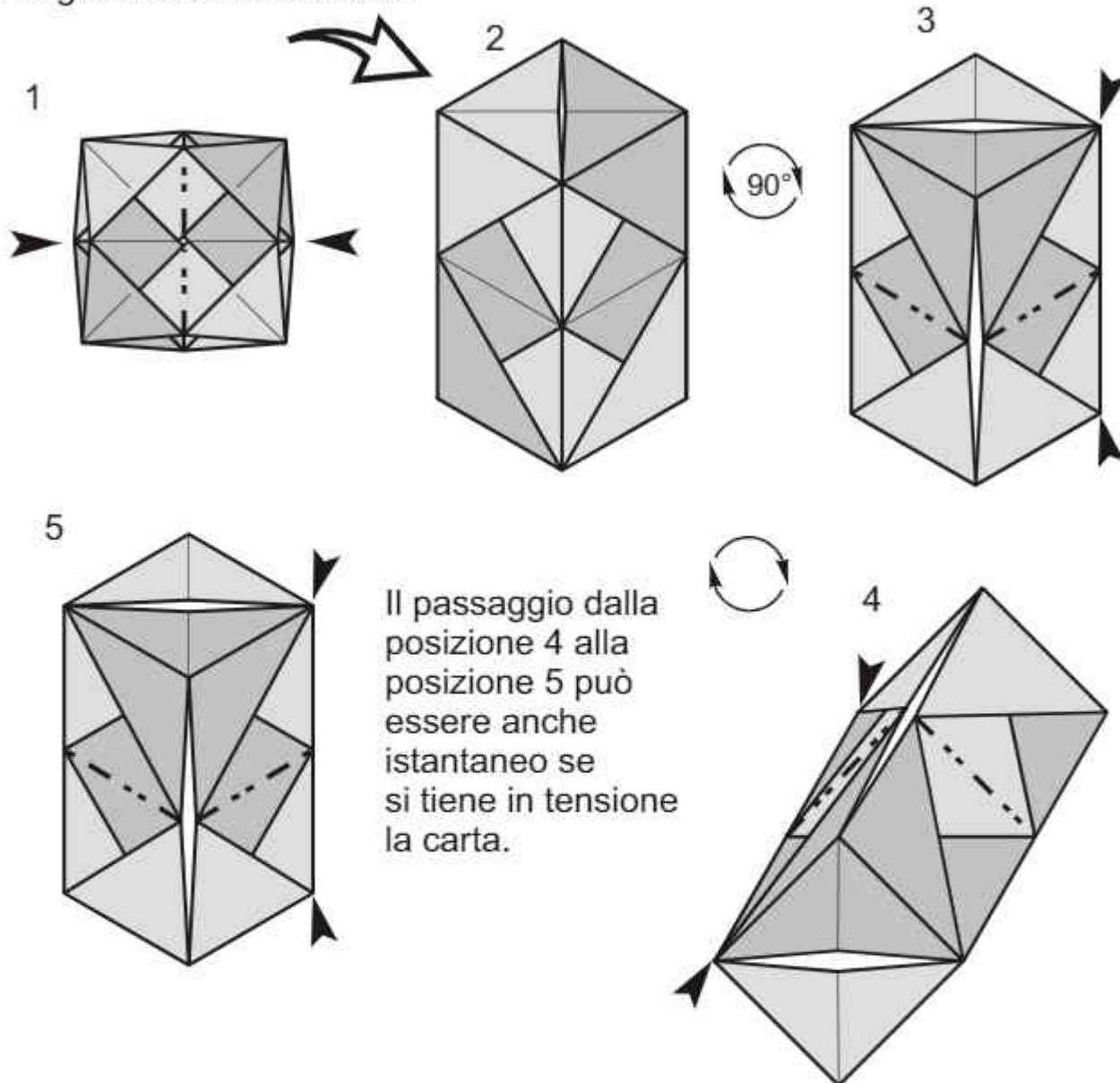

Per giocare all'infinito ripetere i passaggi 4 e 5

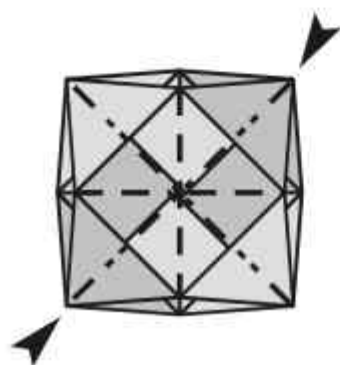

Premendo delicatamente dove indicato, si ottiene un ottaedro piramidato



**ORIGAMI
ARGENTINA**

Asociación Civil Plegando al Sur

**6^o CONVENCION
DE ORIGAMI
ARGENTINA**

TUCUMÁN 2022

Nivel 3

Teselado Atolón / Miguel A. Gañán

©tesegami_origami

DESIGNER/AUTOR: MIGUEL A. GAÑÁN (2022)

DIAGRAM: MIGUEL A. GAÑÁN

Paper: 20 x 20 cm

Final model size: 12.5 x 12.5 cm

Recommended paper: tant, any thin paper

Papel: 20 x 20 cm

Tamaño final del modelo: 12.5 x 12.5 cm

Papel recomendado: tant, otro papel fino

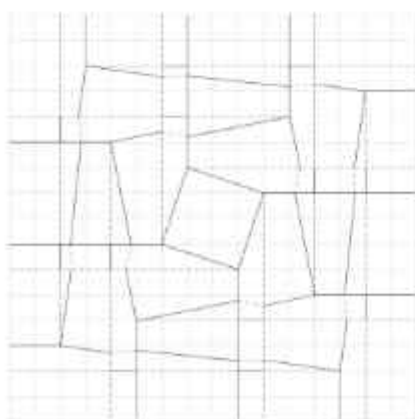
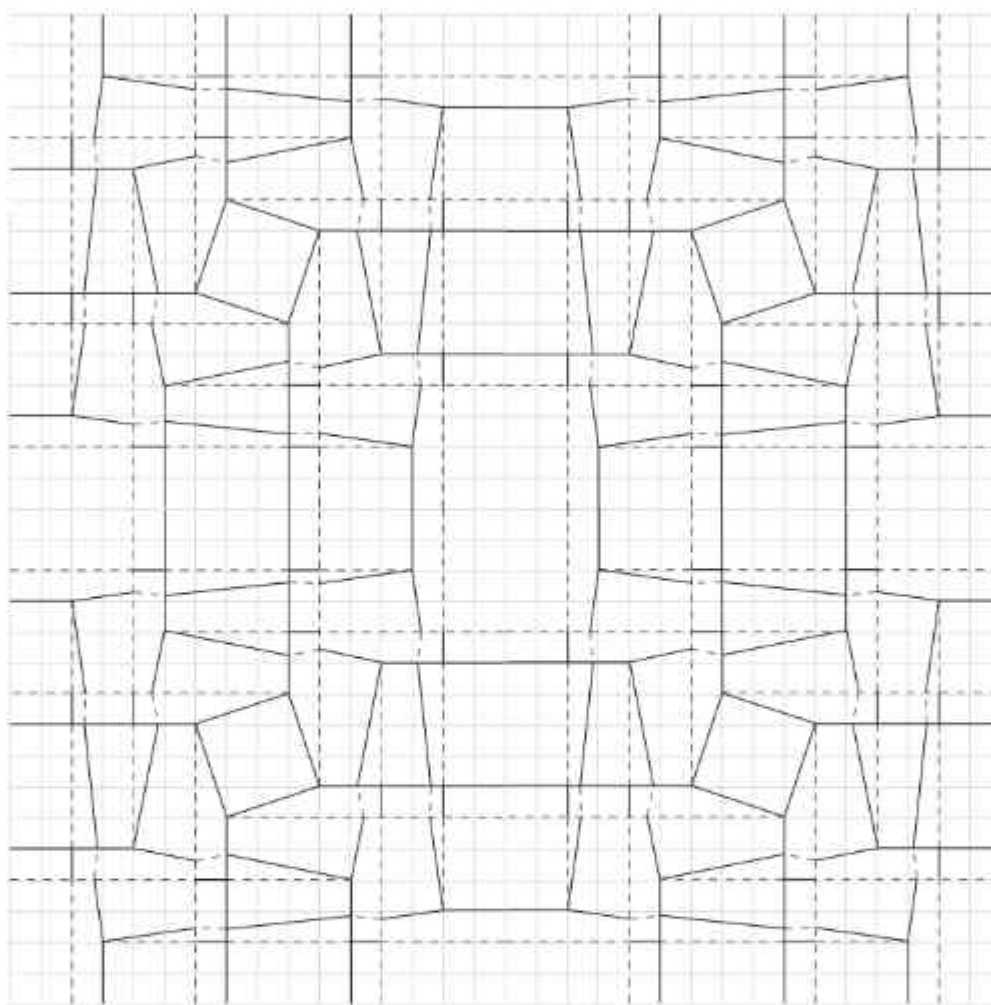

Molecule: CP and folded.
Molécula: CP y plegada.

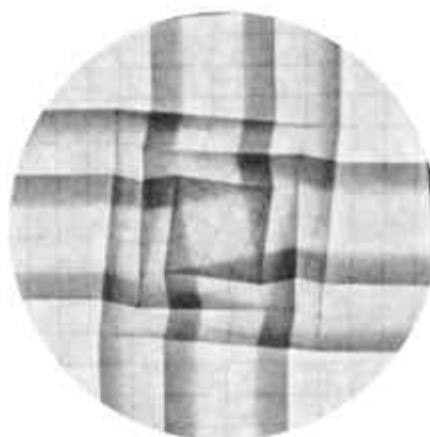

1

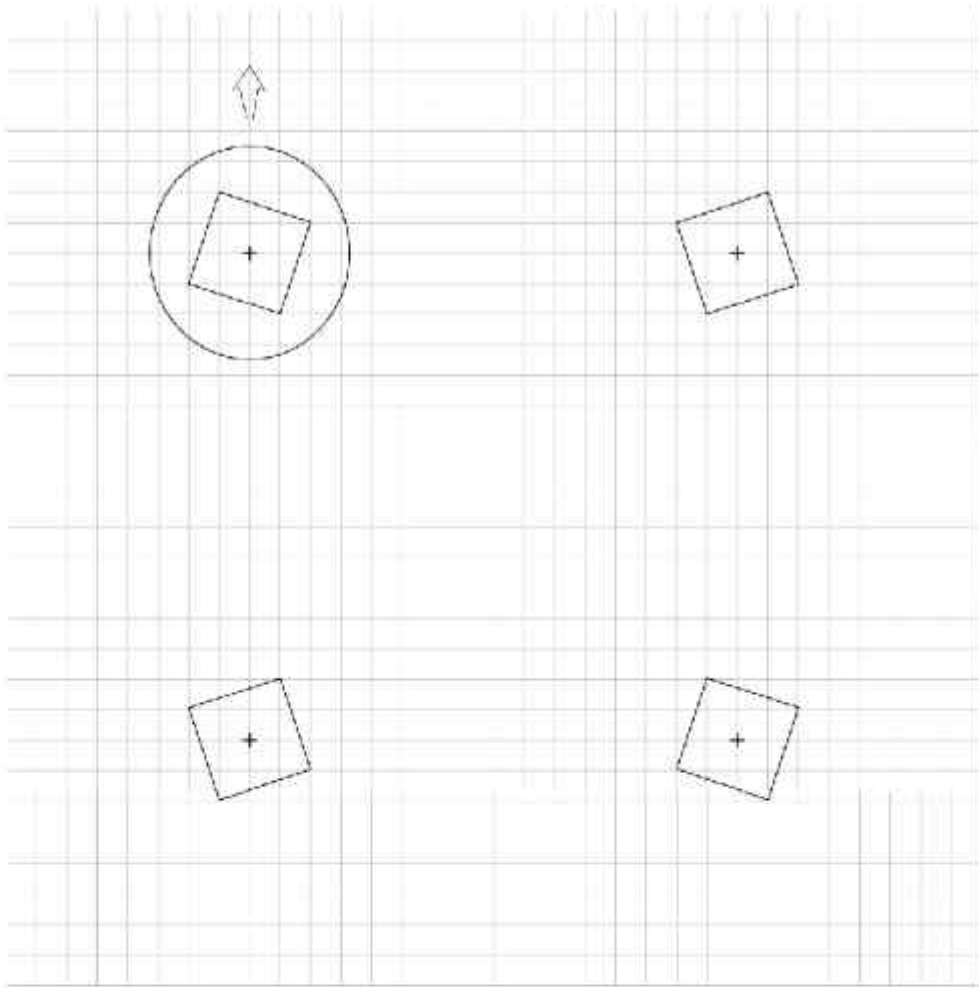

Pre-marcar todos los cuadrados señalados en el diagrama. Hay 16 espacios entre centros de cuadrados.

2

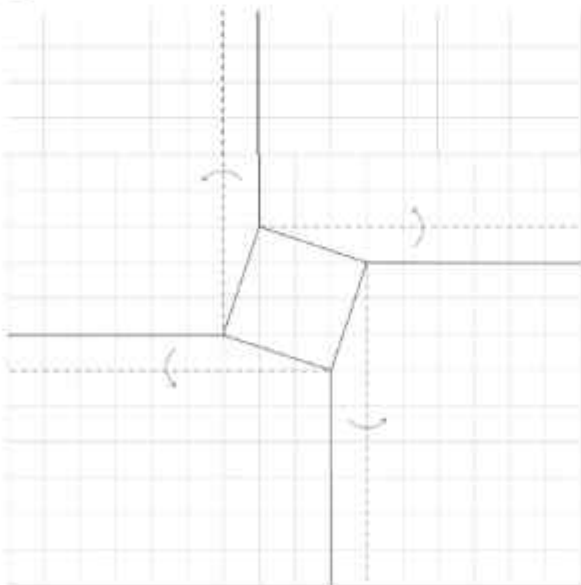

Plegar un giro cuadrado abierto de doble tamaño.

3

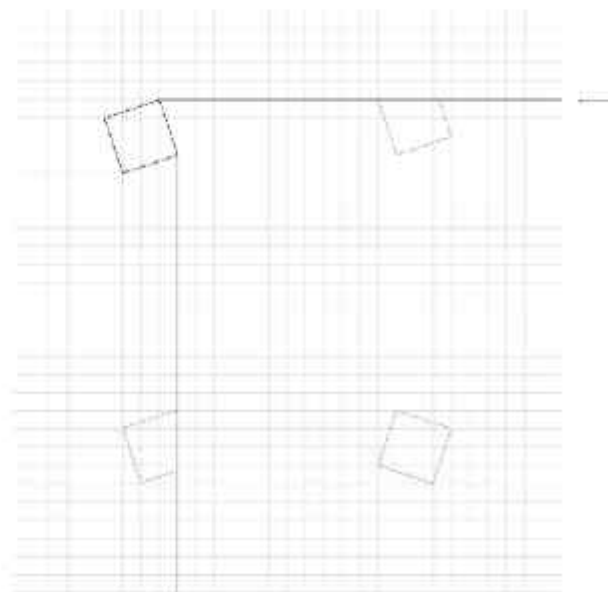

4

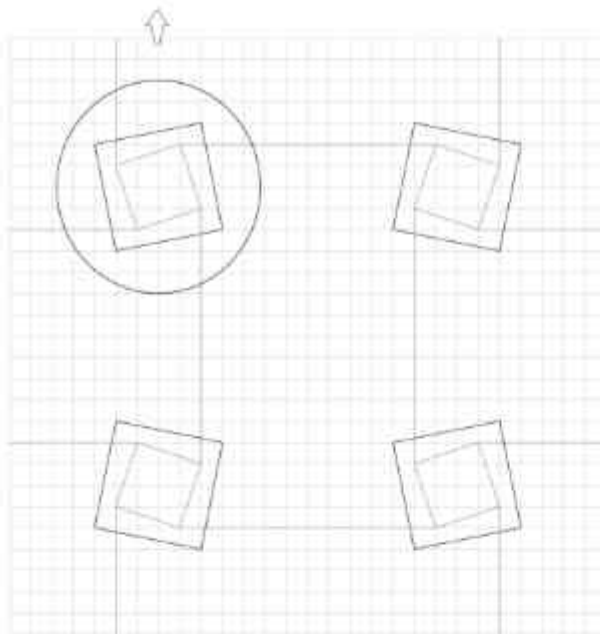

Repetir el giro cuadrado en todo los lados del cuadrado. Pre-marcar el segundo cuadrado.

5

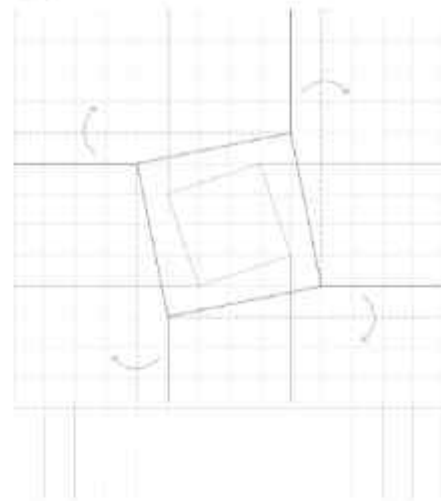

Plegar un segundo giro cuadrado usando los pliegues en azul/rojo.

6

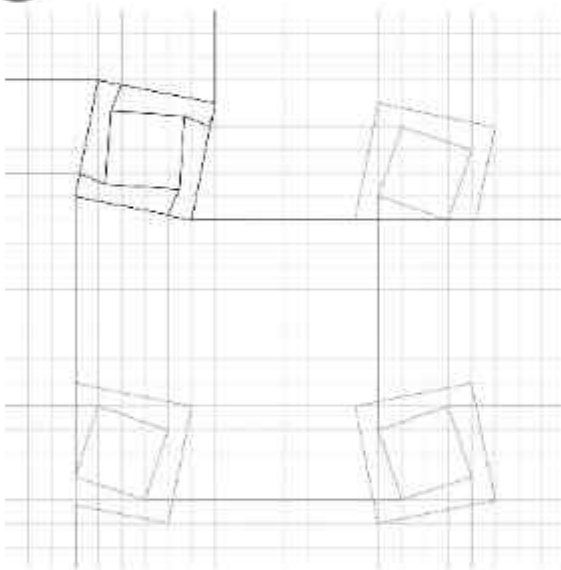

7

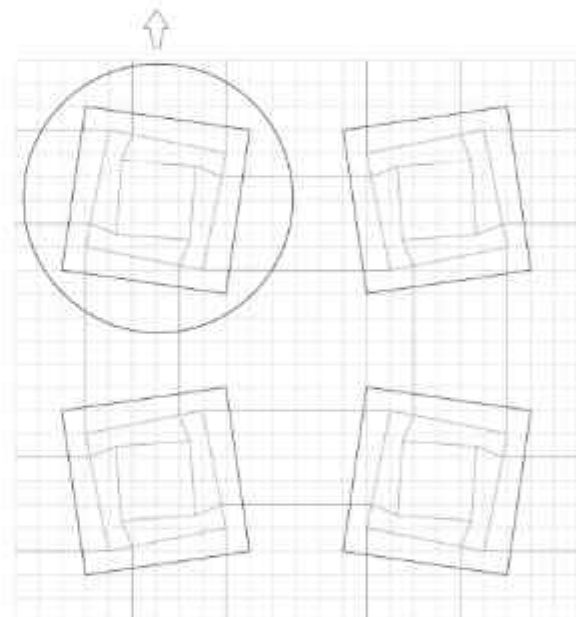

Repetir el segundo giro cuadrado en todo los lados del cuadrado. Pre-marcar el tercer cuadrado.

8

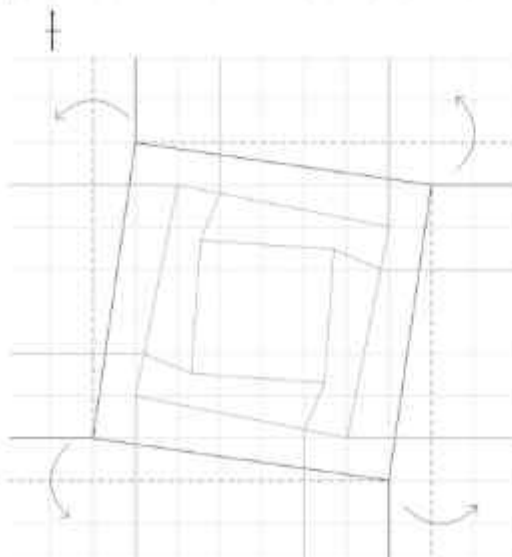

Plegar el tercer giro cuadrado usando los pliegues en azul/rojo.

9

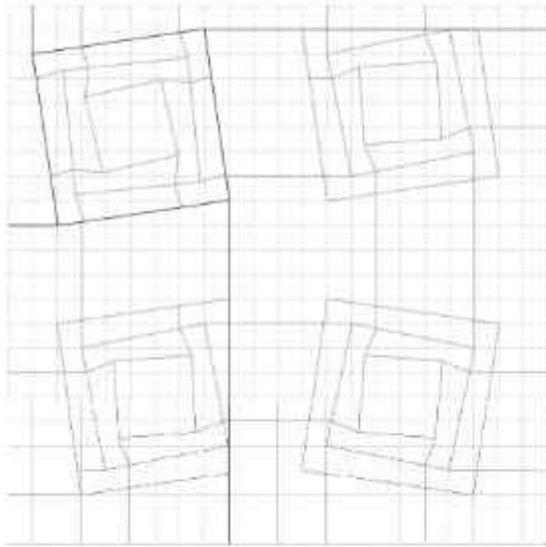

10

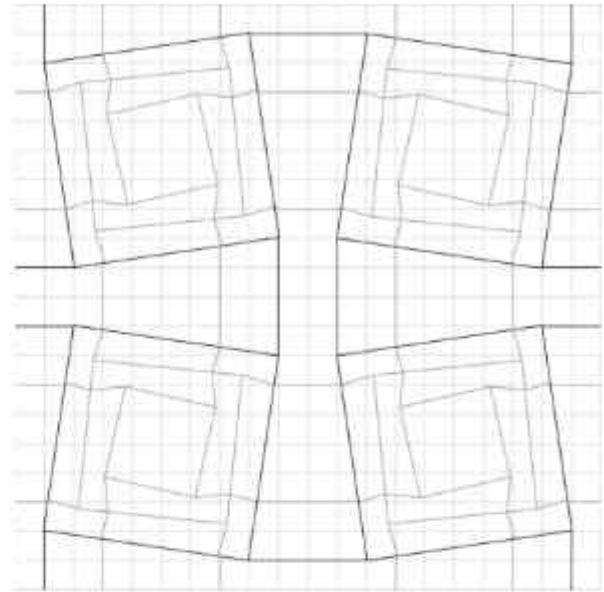

Repetir el tercer giro cuadrado en
todo los lados del cuadrado.
Modelo terminado.

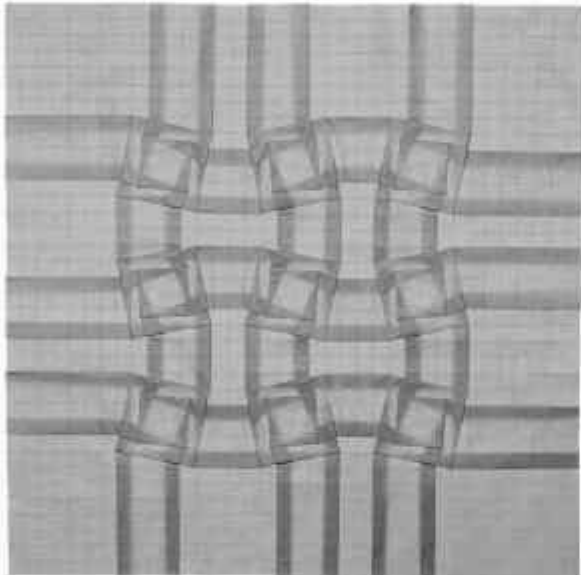

En verde, modelo en papel tant, trama de
48 divisiones y 2 giros cuadrados.
En blanco, modelo en papel Alios Kraft,
trama de 64 divisiones y 3 giros cuadrados.



Miguel Ángel Gañán
Facebook: Miguel Gañán
Flickr: mganans
IG: tesejami_origami
Mail: mganan_es@yahoo.com

Itik Pato / Rhanu Pradipta

Indonesia, 8-2021
@rhanuorigami/
Rhanu Pradipta
diagram: Hadi Tahir
©haditahir_ Origami Hari Hadi

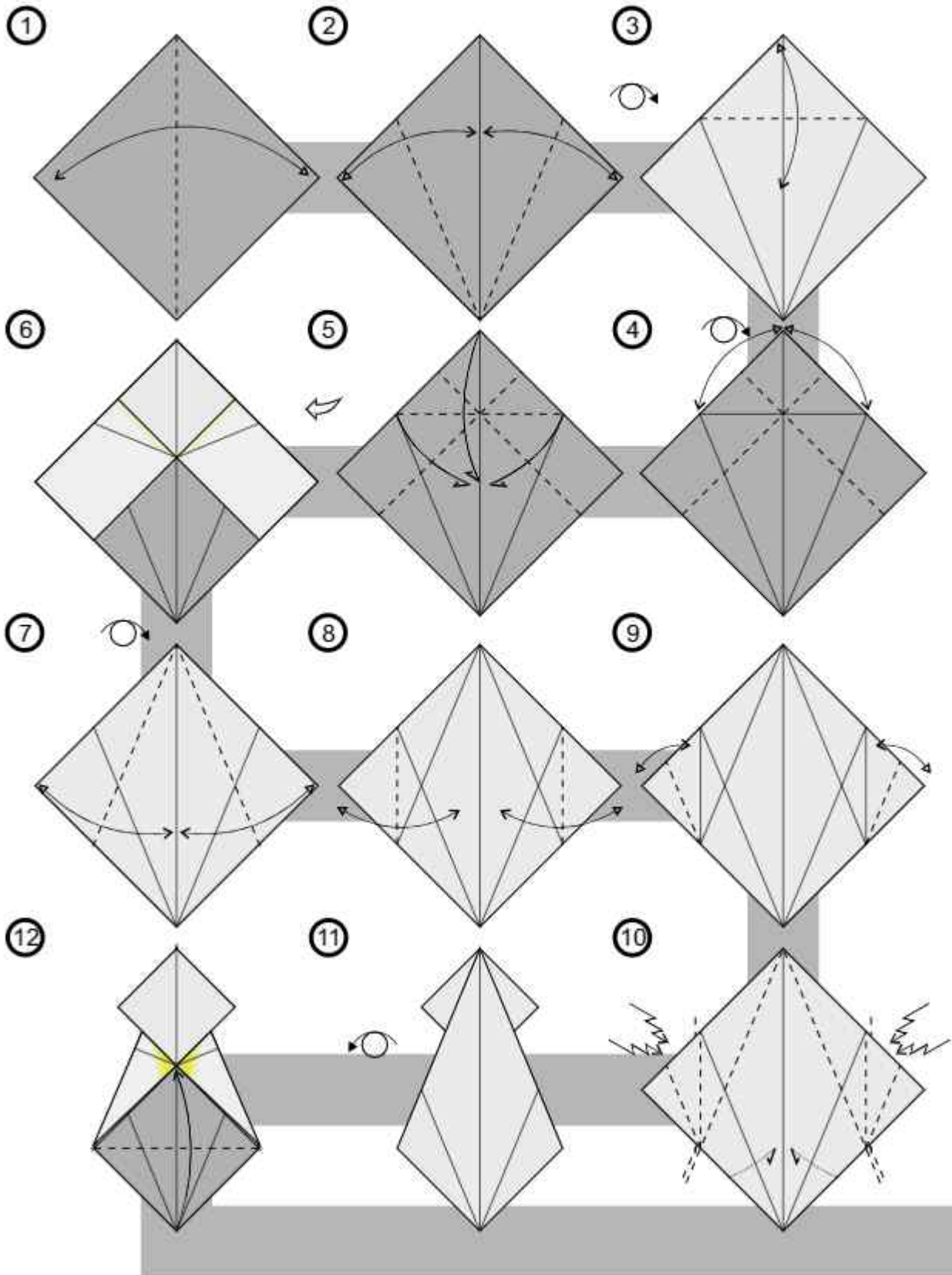

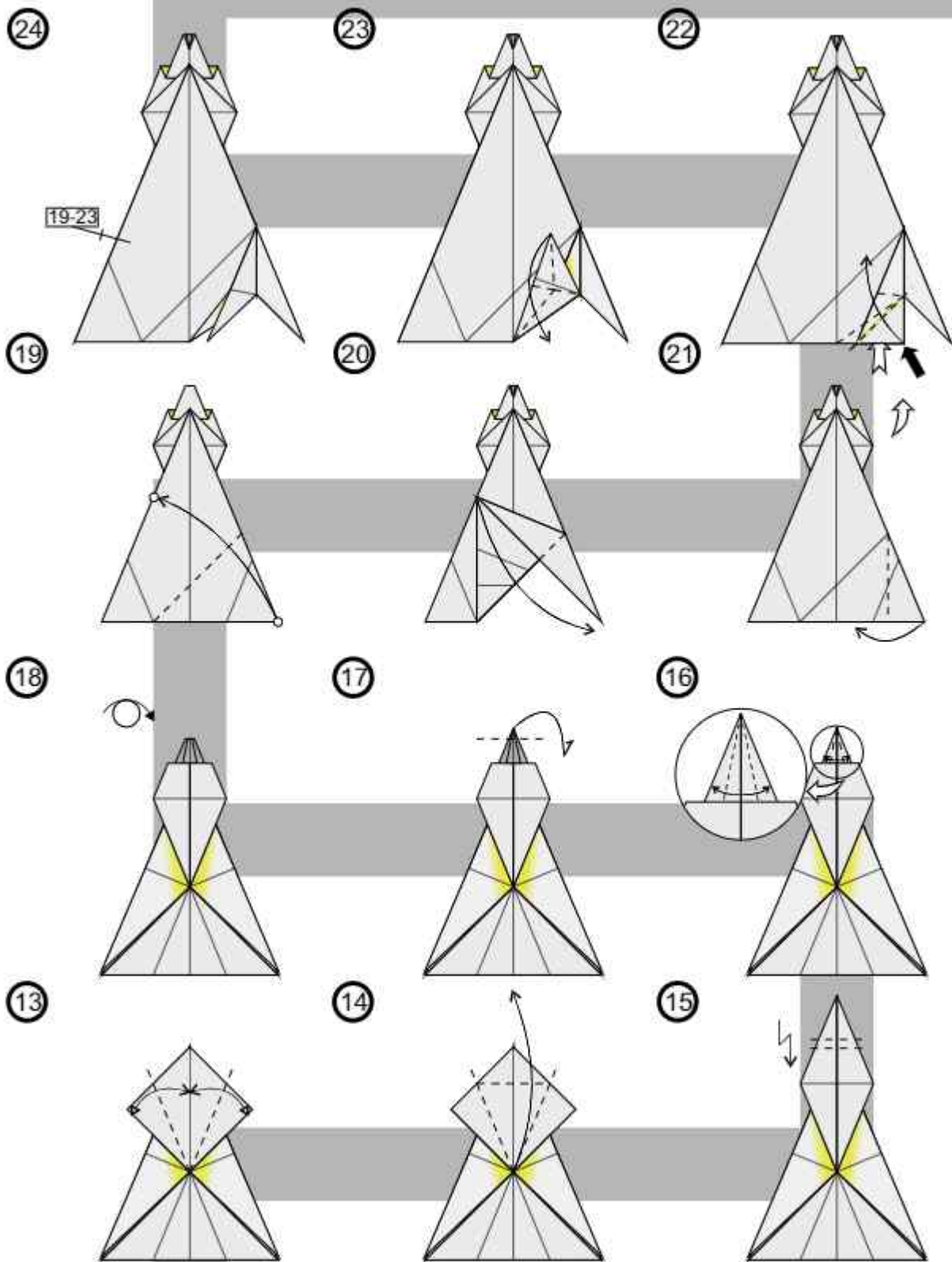

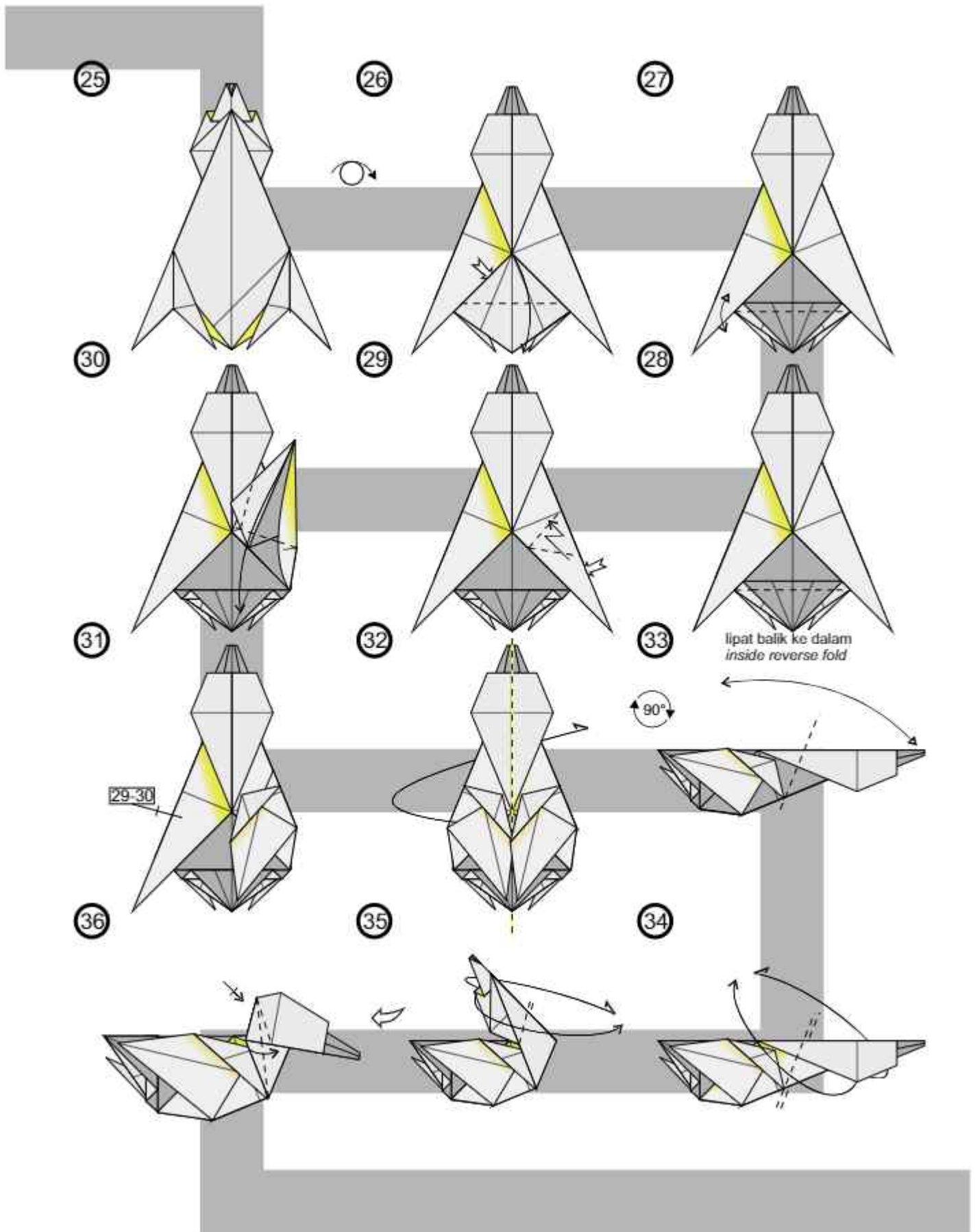

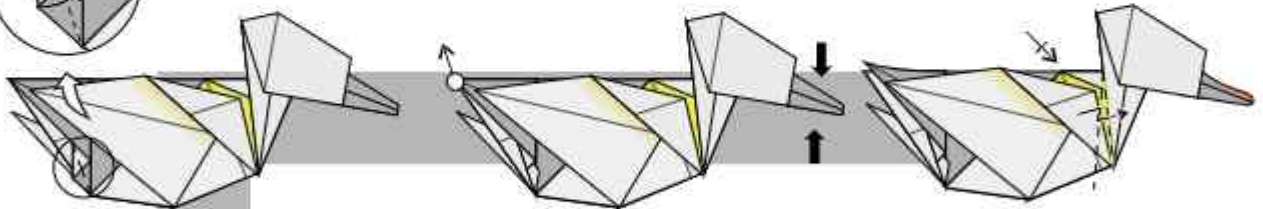
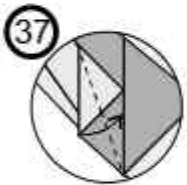
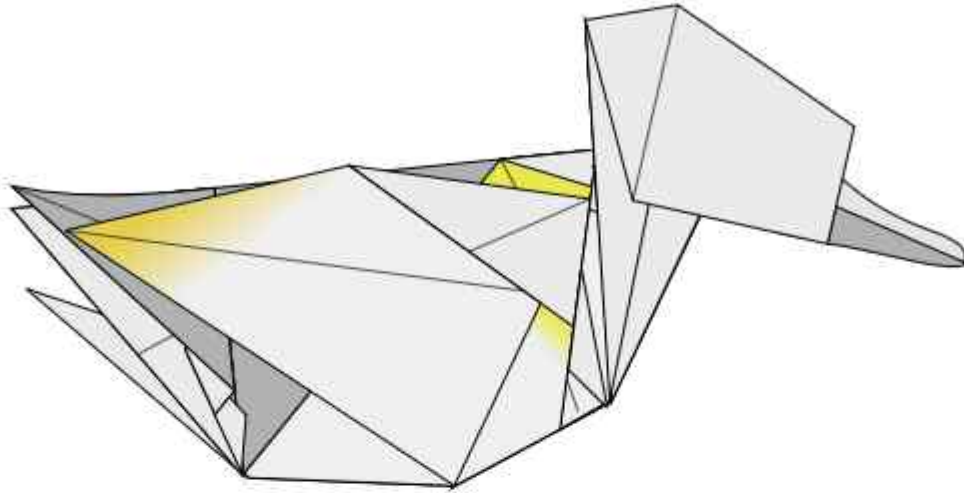

Camaleón / Oz Neyer

● Creador: Ozneyer
Diagramas: Morgan Lozano

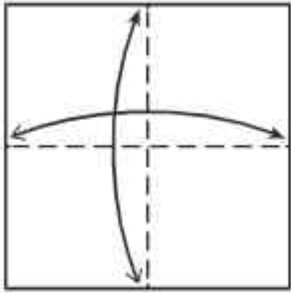
- 

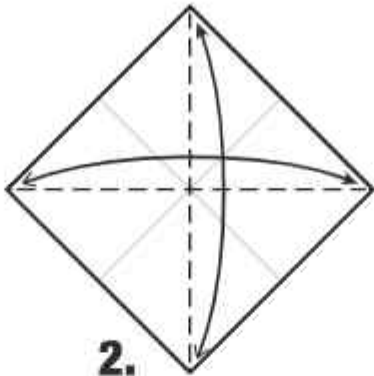
1.
- 

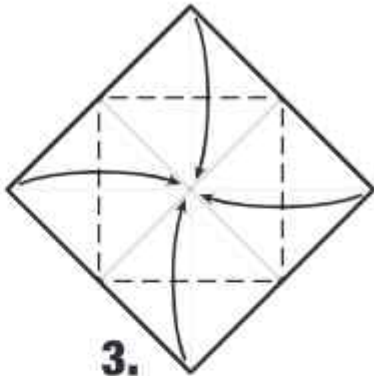
2.
- 

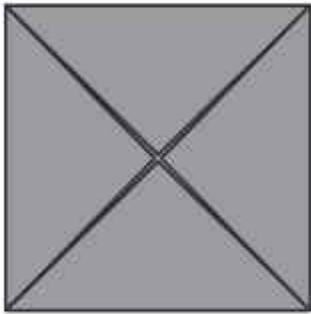
3.
- 

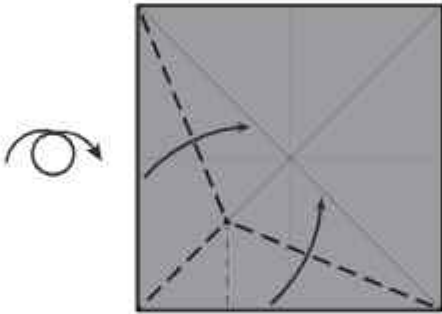
4. Turn over.
- 

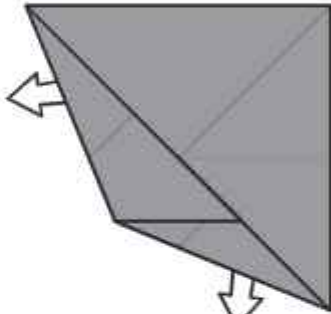
5. Make a rabbit-ear fold.
- 

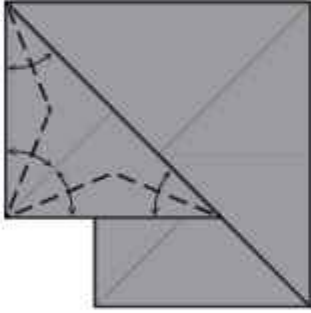
6. Unfold back layers.
- 

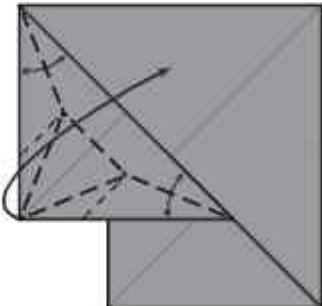
7. Pre-crases.
- 

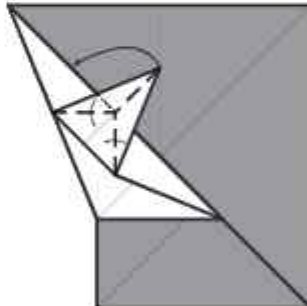
8. Collapse as shown.
- 

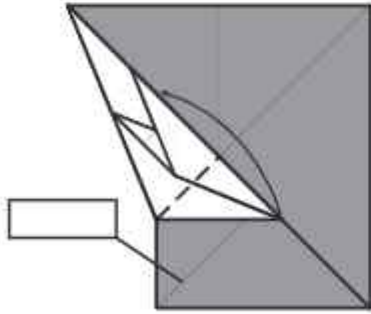
9. Make a rabbit-ear fold.
- 

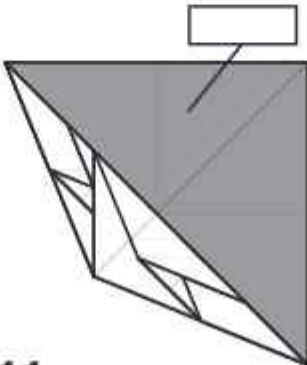
10. Fold the tip up and repeat down.
- 

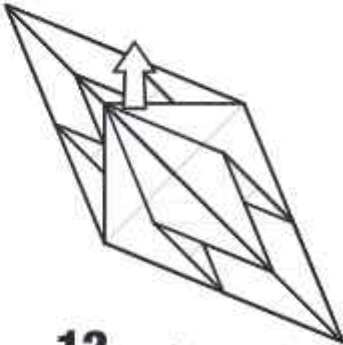
11. Repeat steps on the other half.
- 

12. Unfold only the middle flap.

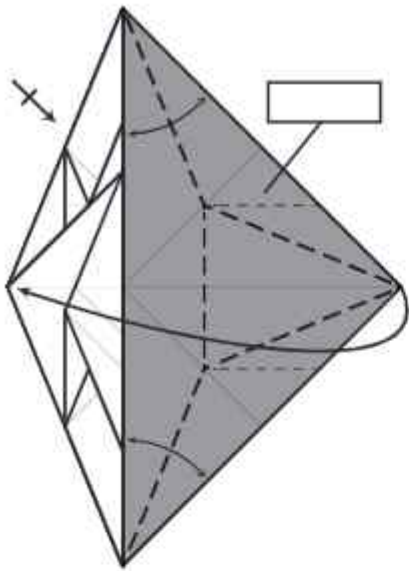

13. Collapse repeatin previous steps and repeat simetrically on the other side.

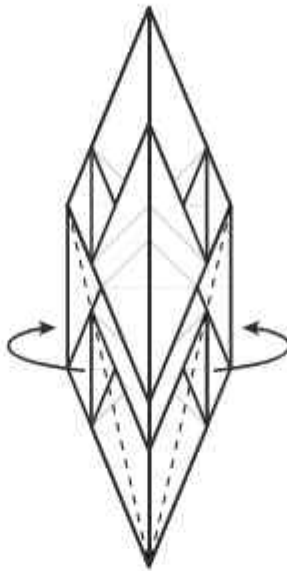

14. Mountain fold all layers.

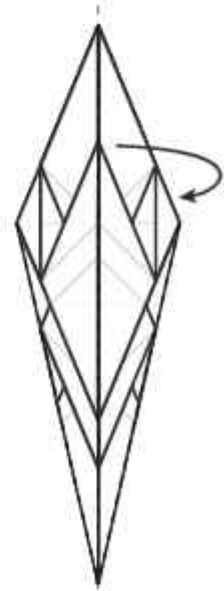

15. Fold the model in half.

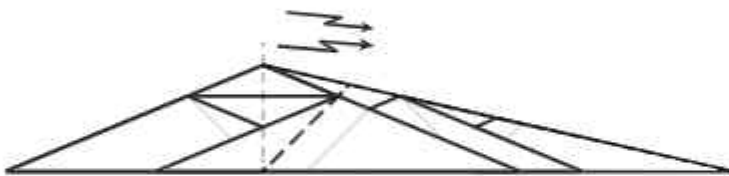

16. Crimp fold all layers.

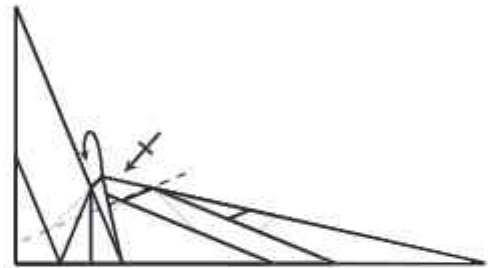

17. Mountain fold usin the layer ede as reference.

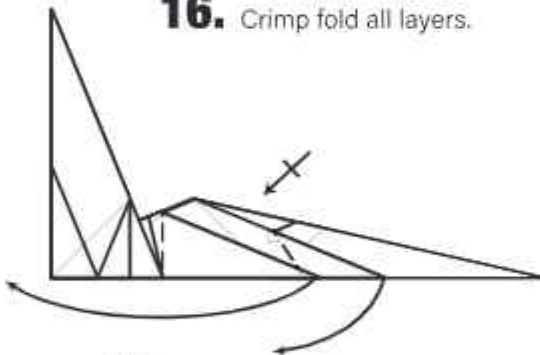

18. alley fold to form les.

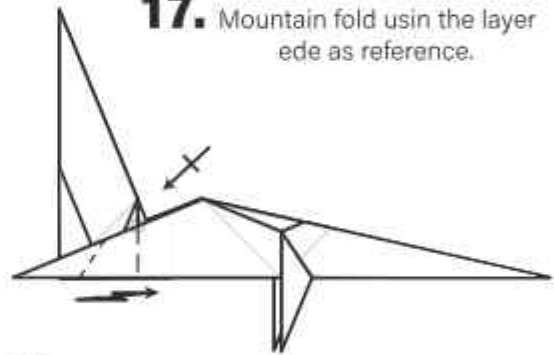

19. Pleat fold startin from the reference point. bserve the reference to mountain fold in the net step.

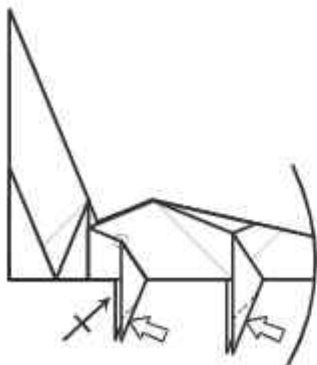

20. Reverse folds in all les.

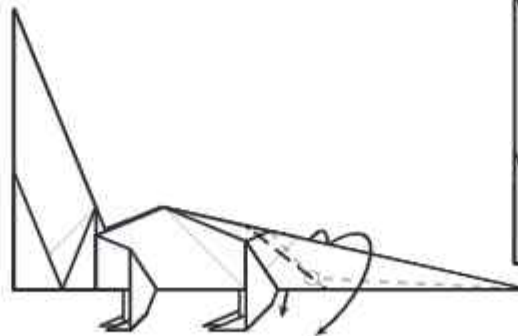

21. outside reverse fold. Use hidden layers as reference.



22. Reverse fold without reference.

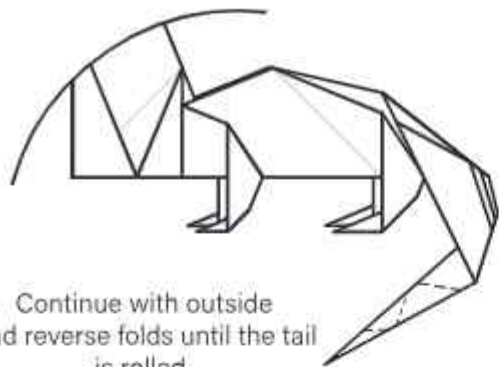

23. Continue with outside and reverse folds until the tail is rolled.

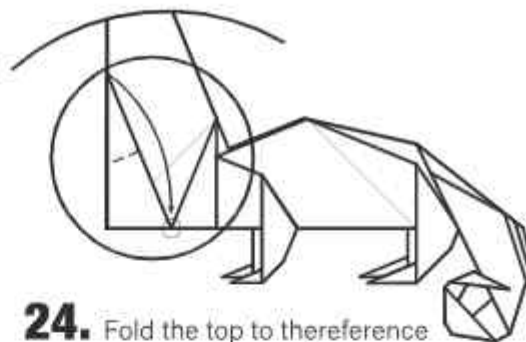

24. Fold the top to the reference point. Zoom in.

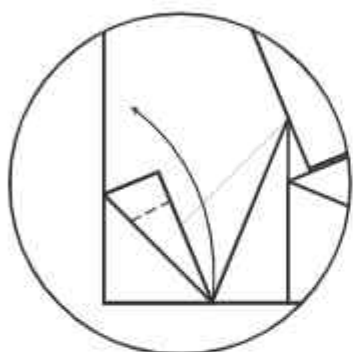

25. Fold approximately as shown.

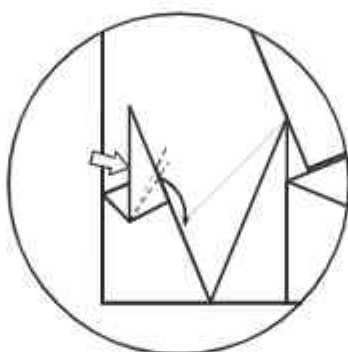

26. Wash fold.

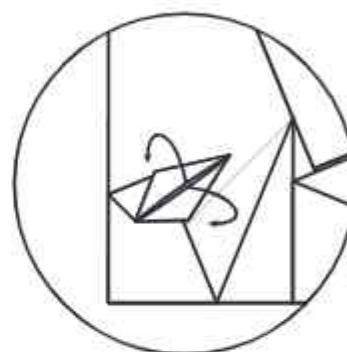

27. Color change to form the eye.

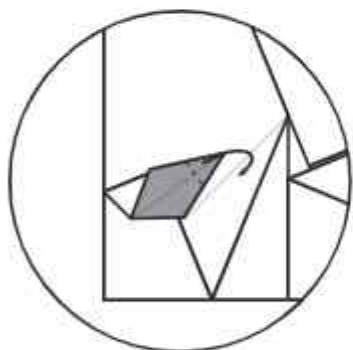

28. Mountain fold the tip to finish eye.

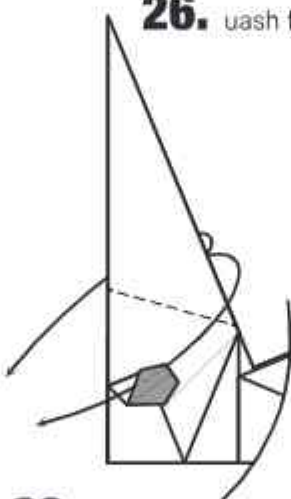

29. Outside reverse fold passing behind the eye.

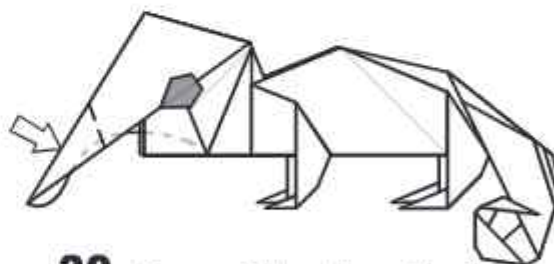

30. Reverse fold and insert the tip into the center layers.

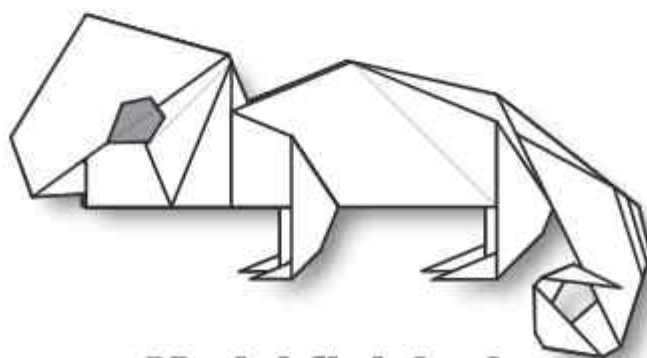

Model finished.

Cardenal / Christophe Boudias

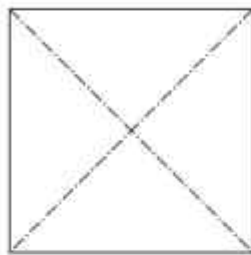

1: Marquer Pli montagne.

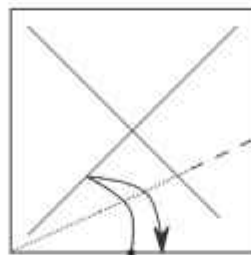

2: Marquer le bord de la feuille.

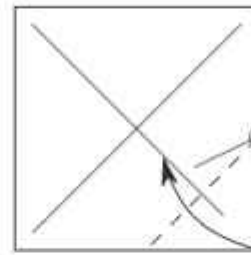

3: Pli vallée.

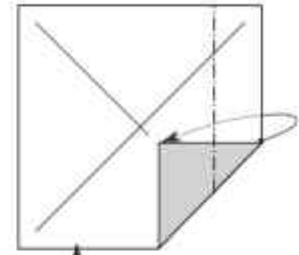

4: Pli montagne, répéter sur l'autre côté.

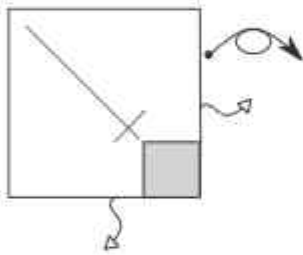

5: Déplier tout.

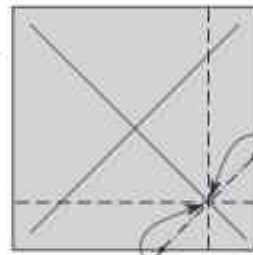

6: Base préliminaire sur le coin de la feuille.

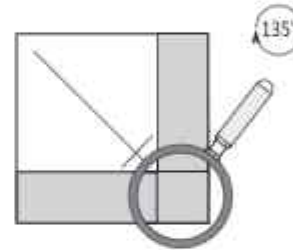

8: Zoom.

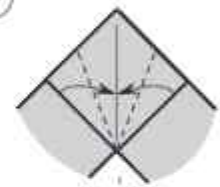

9: Pli vallée.

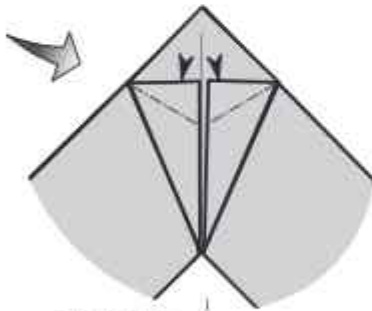

10: Pli aplati.

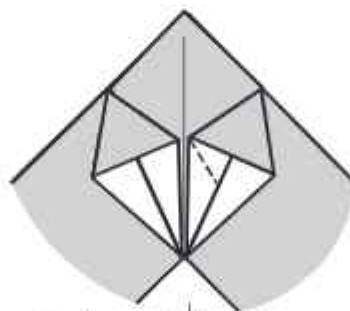

11: Marquer la bissectrice par un pli vallée.

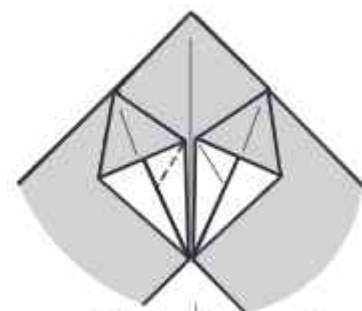

12: Marquer la bissectrice par un pli vallée.

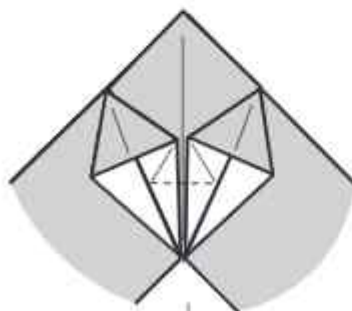

13: Marquer un pli vallée entre les 2 points de références des étapes 11 et 12.

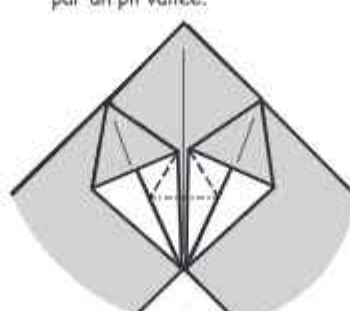

14: Ouvrir et plier vers le haut respecter les plis marqués aux étapes 11-13.



15: Résultat.

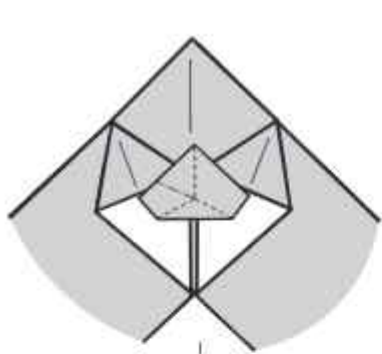

16: Pli en oreille de lapin.

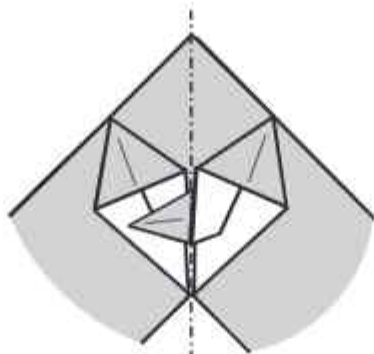

17: Pli montagne le long du modèle et retour à une vue d'ensemble.

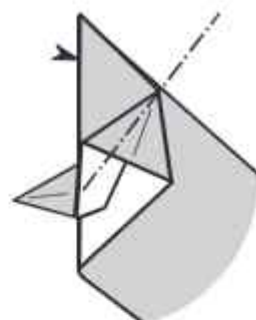

18: Pli inversé intérieur.

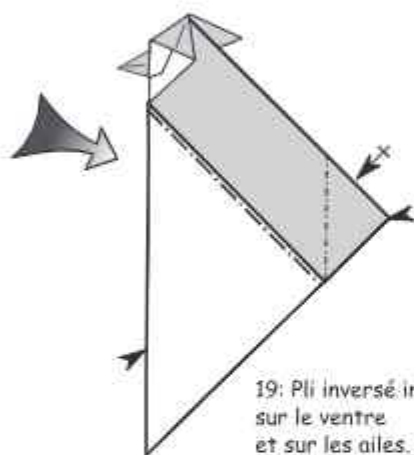

19: Pli inversé intérieur sur le ventre et sur les ailes.

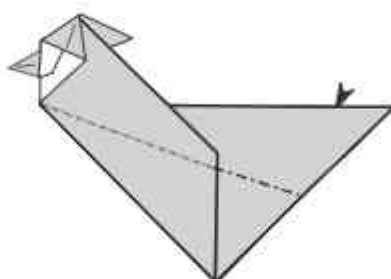

20: Pli inversé intérieur sur le dos.

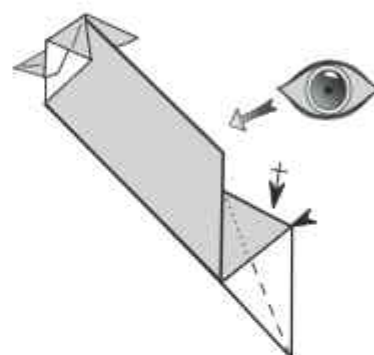

21: Pli inversé intérieur sur la queue.

On passe en vue de dessus.

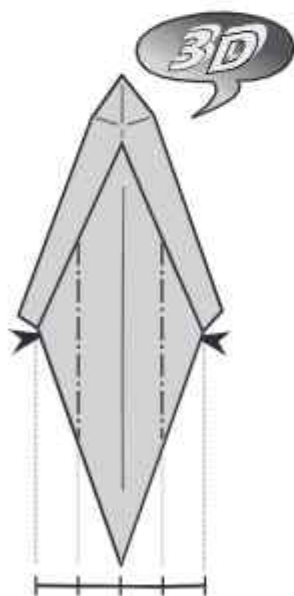

22: Enfoncement ouvert tout le long de la queue. Les références sont placées en bas du modèle.

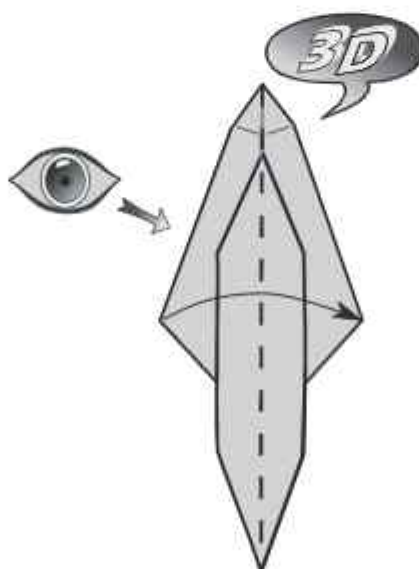

23: plier le modèle en deux suivant la longueur.

Retour à la vue de côté.

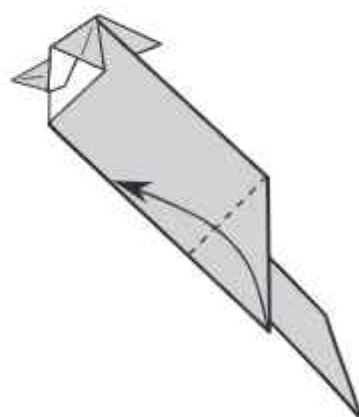

24: Plier l'aile vers le haut par un pli vallée.

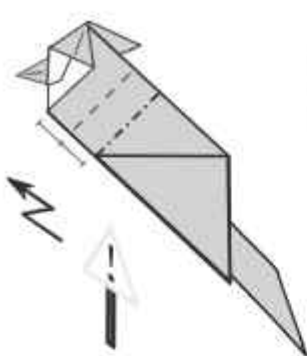

25: Pli zig-zag intérieur,
Attention risque déchirement.



26: Zoom sur la tête.

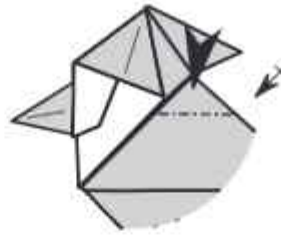

27: Pli inversé intérieur
sur les épaules.

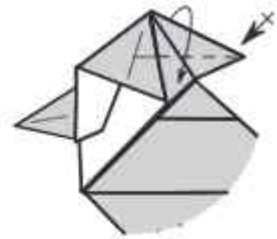

28: Pli vallée sur l'épaisseur
de papier de dessus.
Répéter derrière.

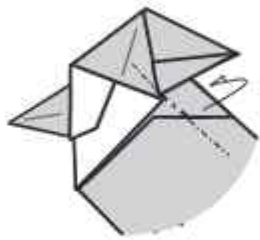

29: Pli montagne à l'intérieur
du modèle pour affiner le cou
de l'oiseau et retour à la vue
d'ensemble.

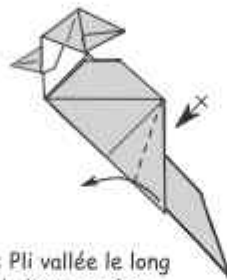

30: Pli vallée le long
de la ligne repère.
Répéter derrière.

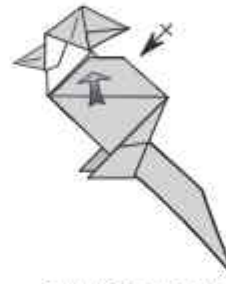

31: Libérer les ailes
en tirant vers le haut.

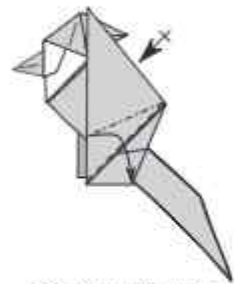

32: Pli vallée puis
montagne pour
changer la couleur
des pattes.

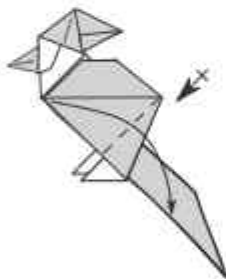

33: Abaisser les ailes.

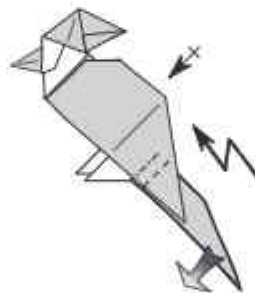

34: raccourcir la queue
par un pli zig-zag.

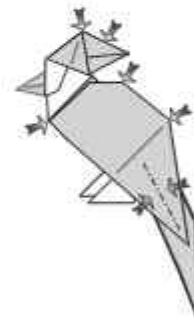

35: Modelé le corps
pour donner du volume.

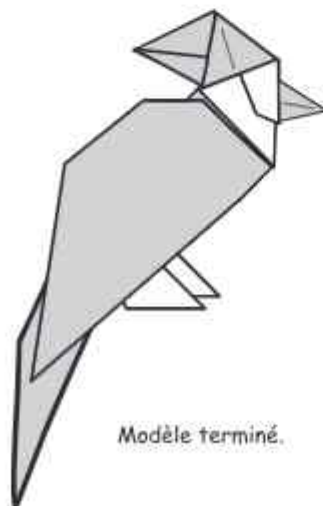

Modèle terminé.

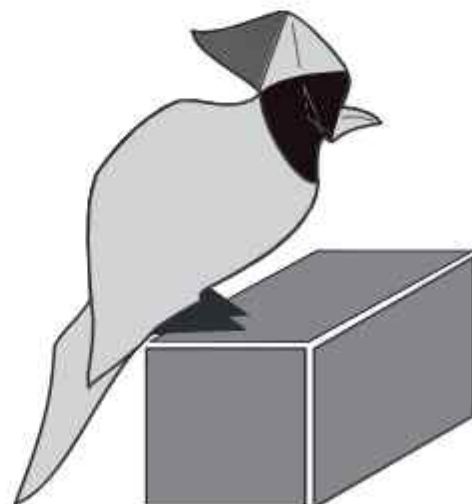

Cumi Cumi / Rhanu Pradipta

Rhanu Pradipta

Indonesia, 8-2021

@rhanuorigami/

Rhanu Pradipta

diagram: Hadi Tahir

Origami Harri Hadi

@haditahir_

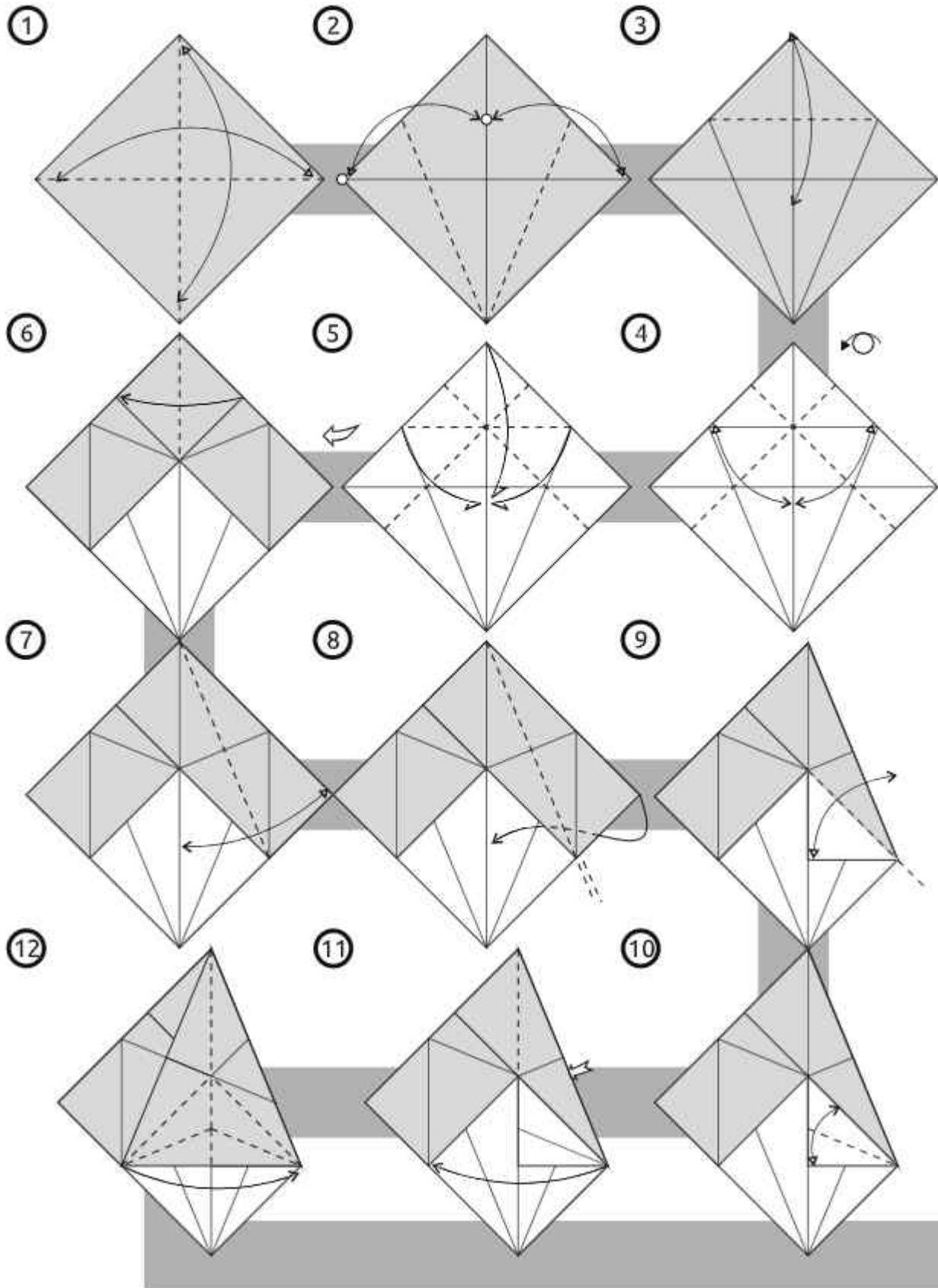

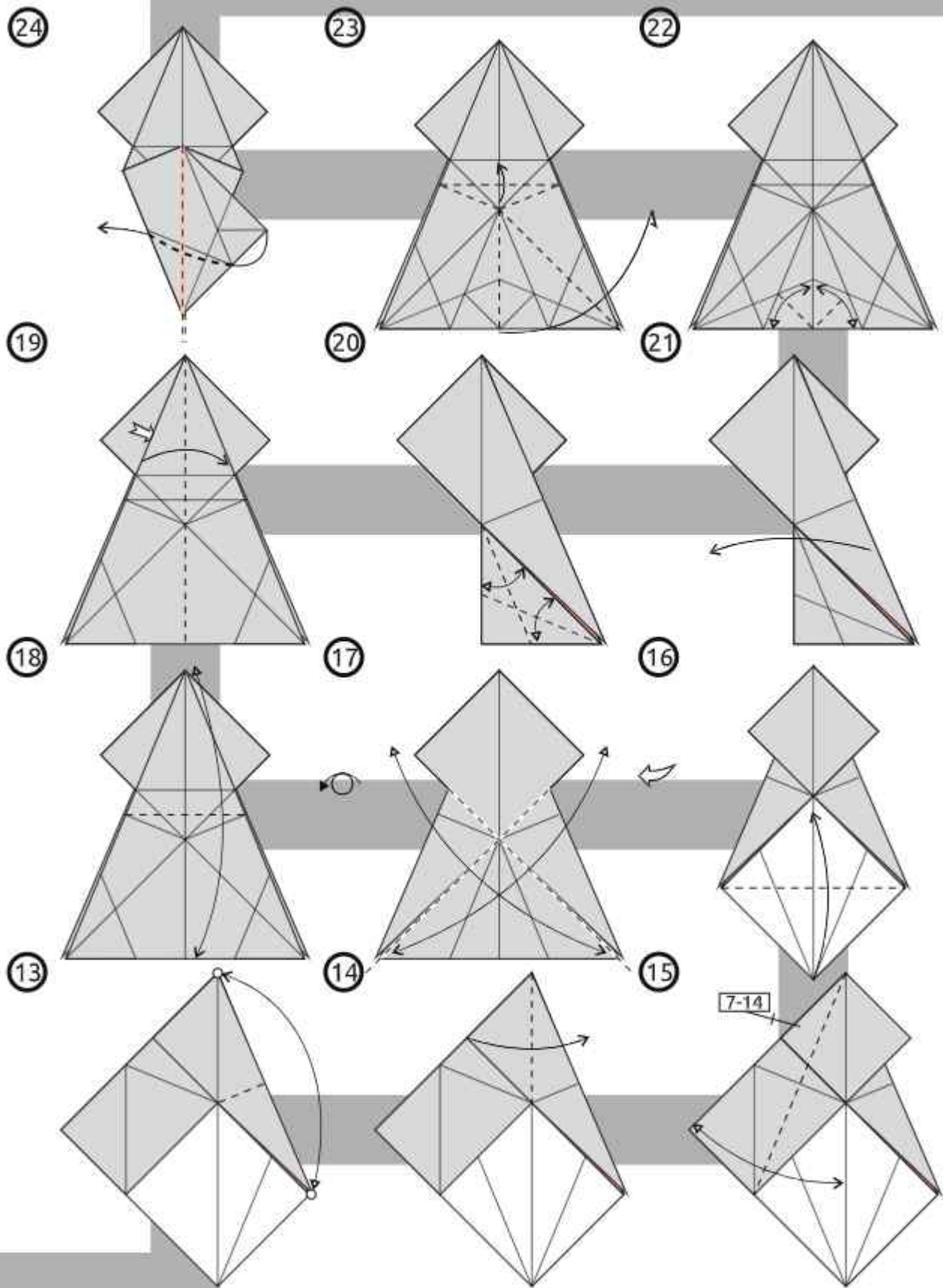

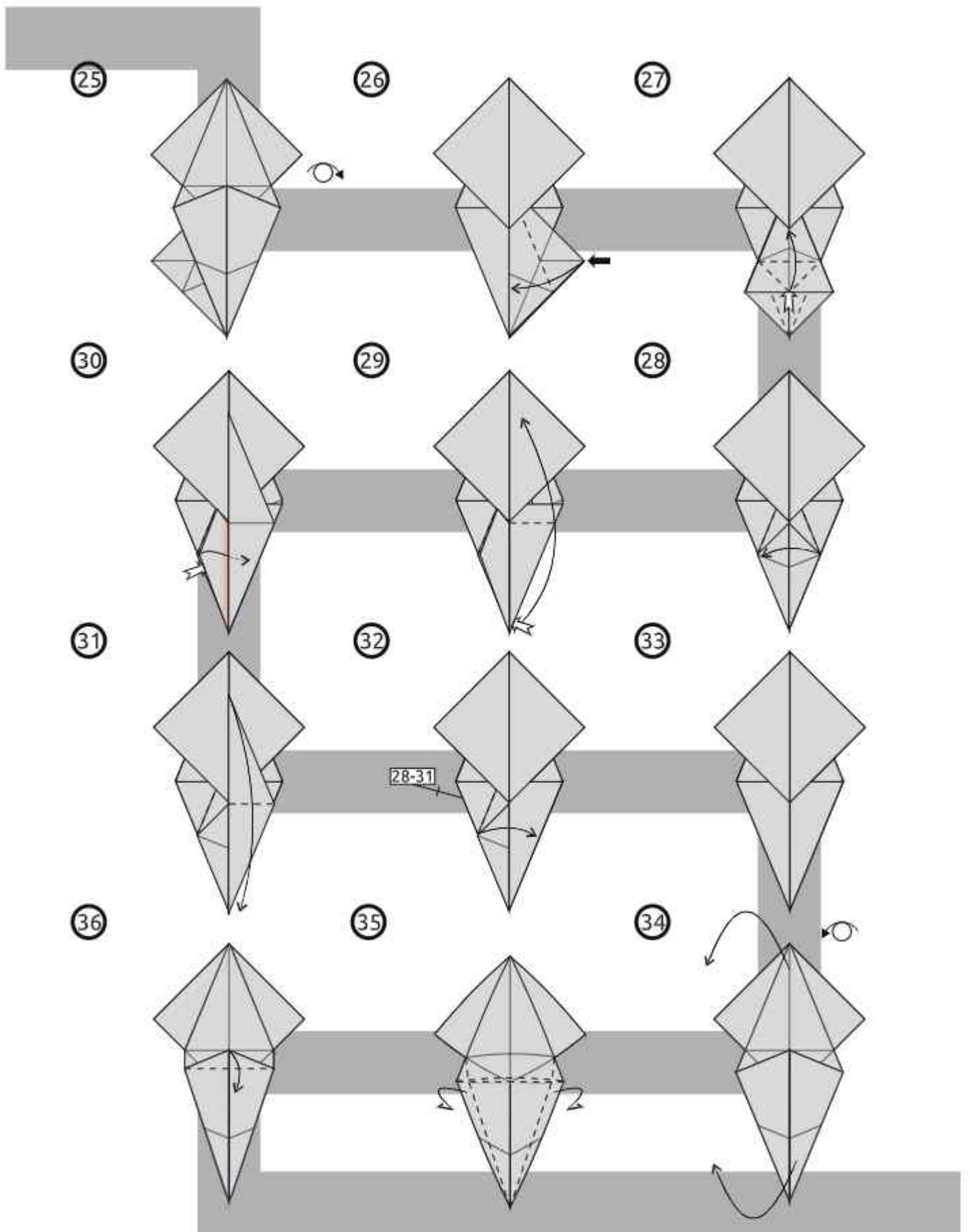

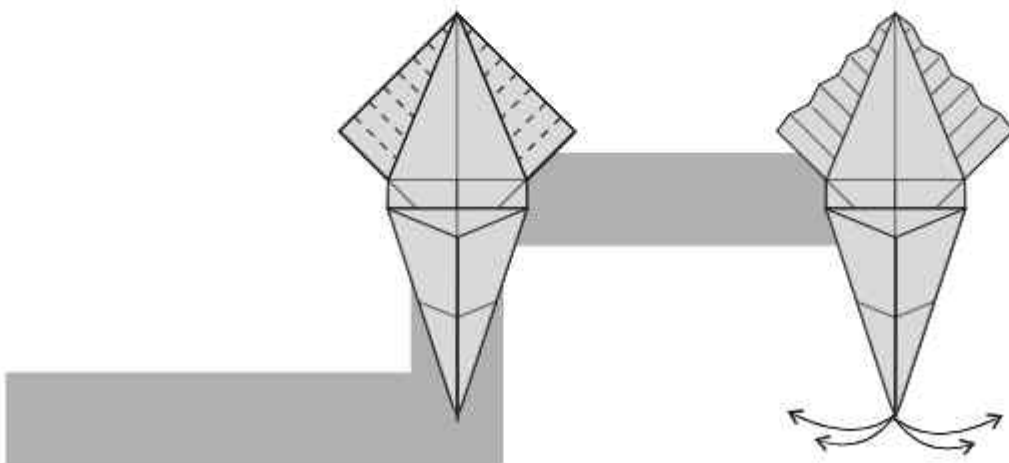
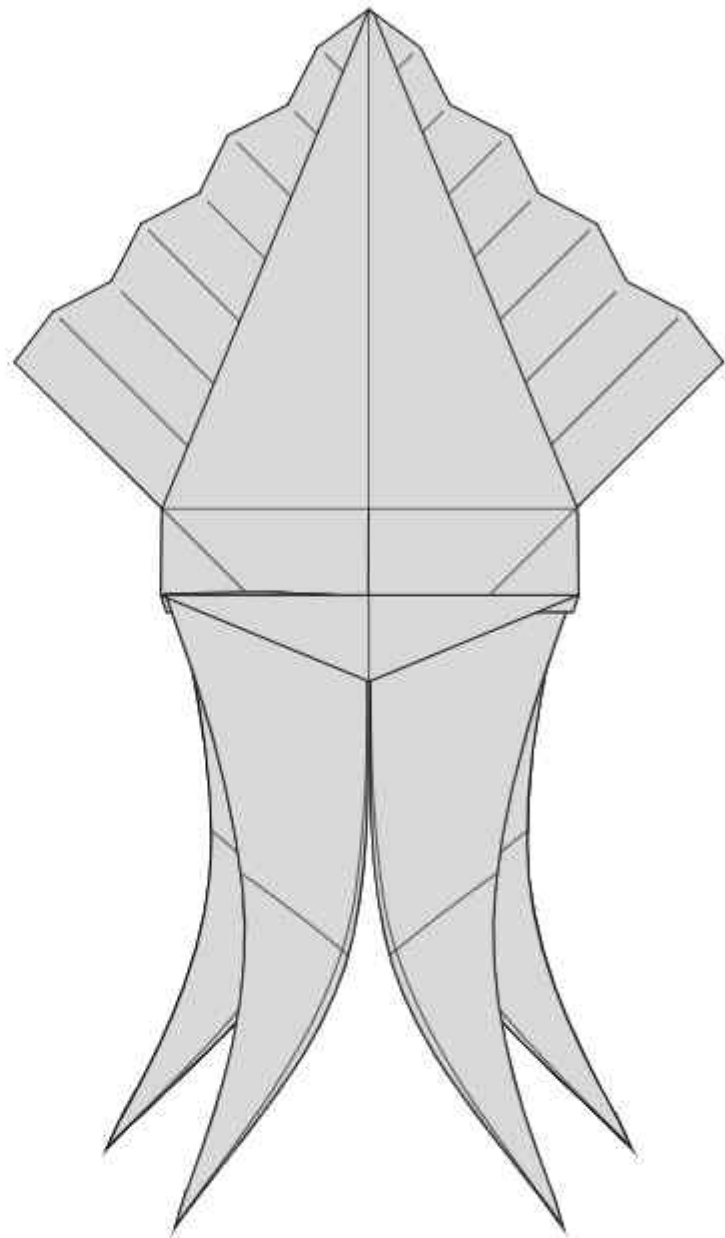

Duende del Bosque / Xabier Sevillano

Xabier Sevillano (IG: @xevi6960)

Tamaño: 20x20 cm

Papel bicolor: sí (preferentemente verde para la piel)

Dificultad: intermedia

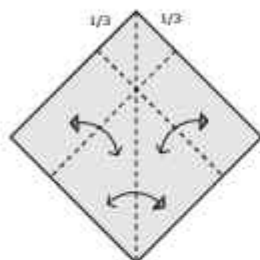
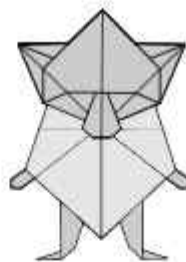

1. Color de la túnica arriba.
Doblar y desdoblar

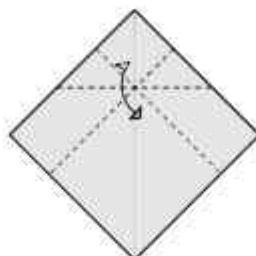

2. Doblar y desdoblar

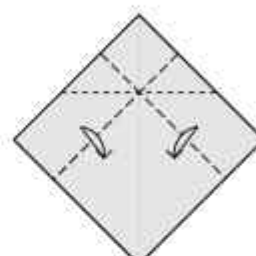

3. Base preliminar desplazada

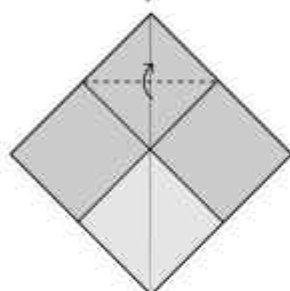

4. Pliegue en valle

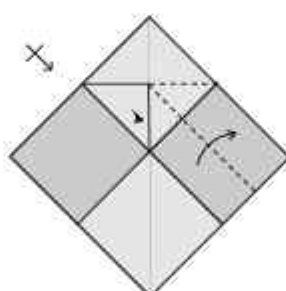

5. Pliegue pivotante (*swivel fold*).
Repetir en el otro lado

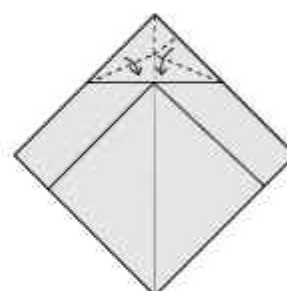

6. Pliegue oreja de conejo

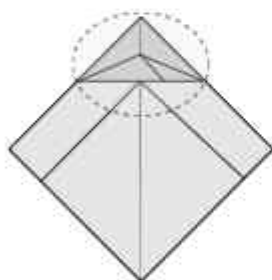

7. Detalle de la cabeza

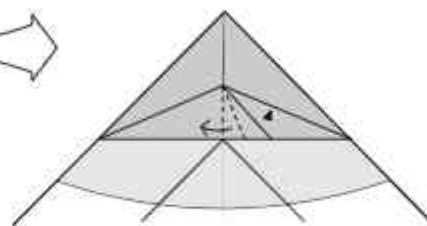

8. Abrir y aplastar

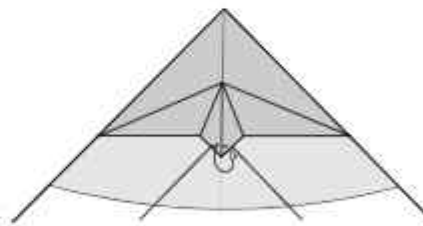

9. Pliegue en montaña

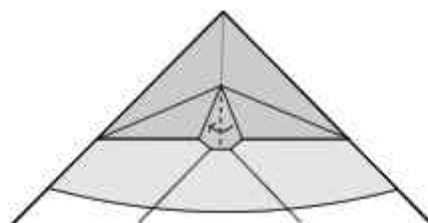

10. Pliegue en valle

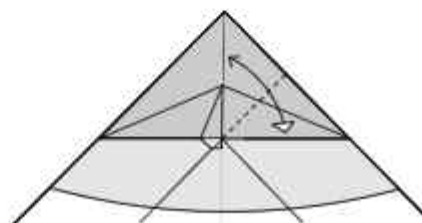

11. Doblar y desdoblar

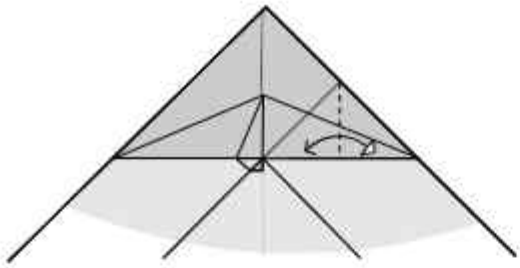

12. Doblar y desdoblar

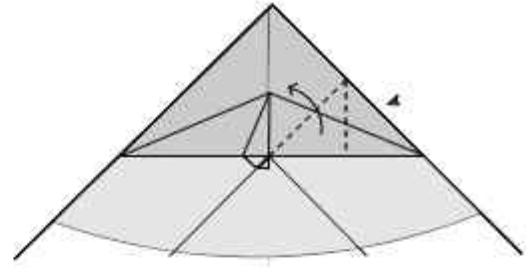

13. Abrir y aplastar

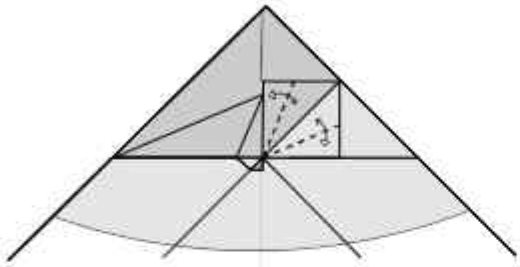

14. Doblar y desdoblar

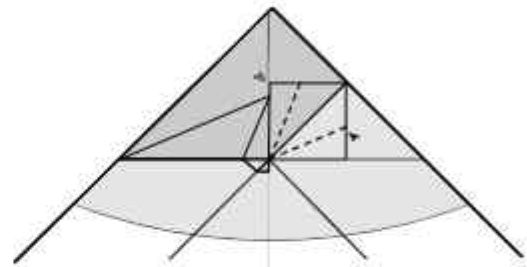

15. Hundido

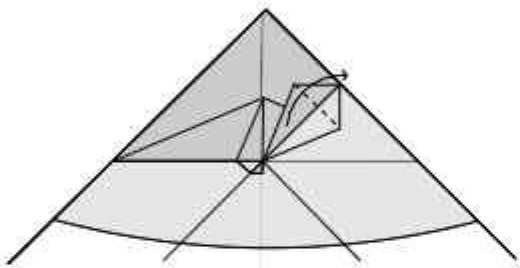

16. Pliegue en valle (levantar la punta)

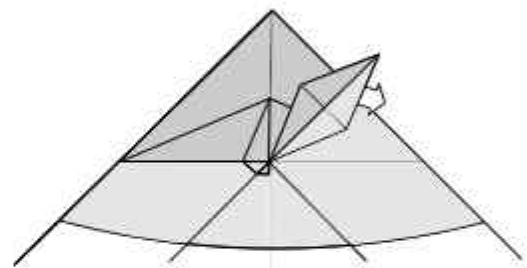

17. Sacar papel del lado superior

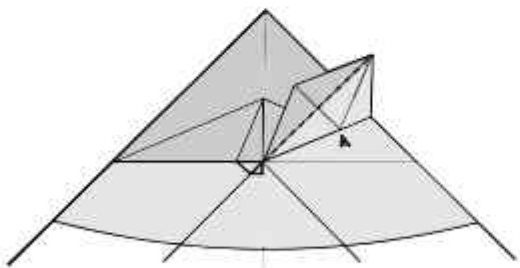

18. Revertir la oreja

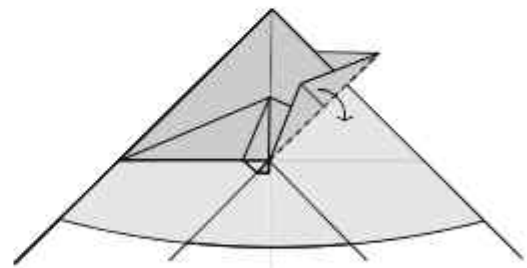

19. Pliegue en valle

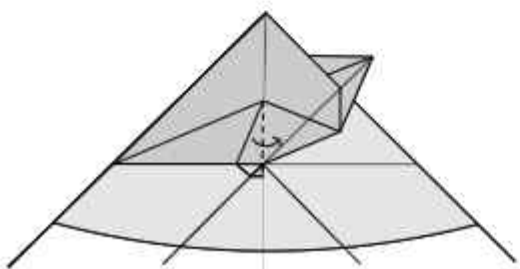

20. Pliegue en valle

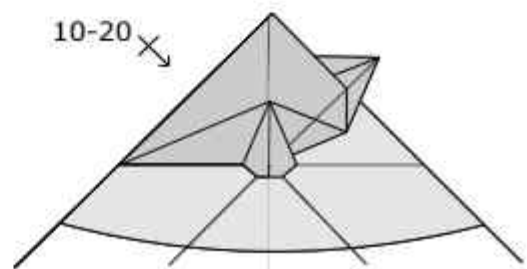

21. Repetir pasos 10 a 20

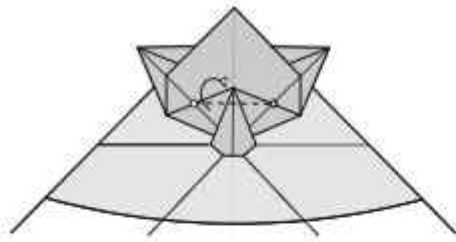

22. Pliegue en montaña

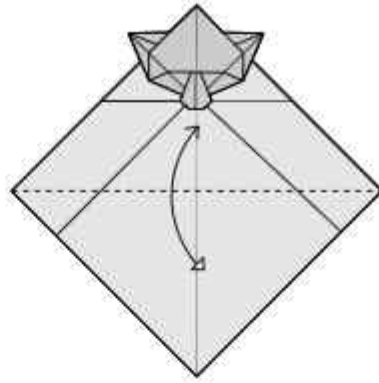
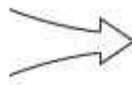

23. Doblar y desdoblar

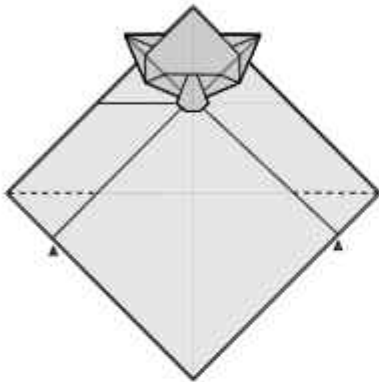

24. Hundir los extremos

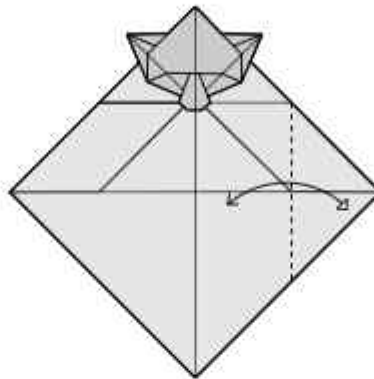

25. Doblar y desdoblar

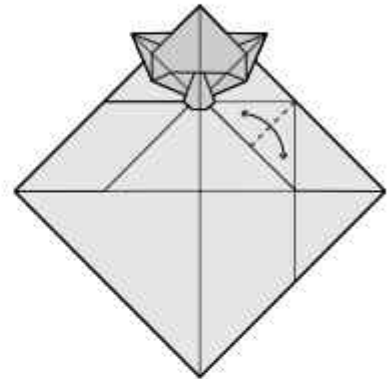

26. Doblar y desdoblar

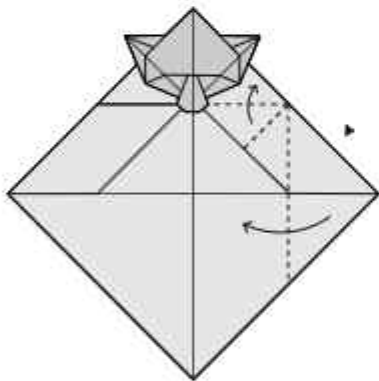

27. Pliegue pivotante (*swivel fold*)

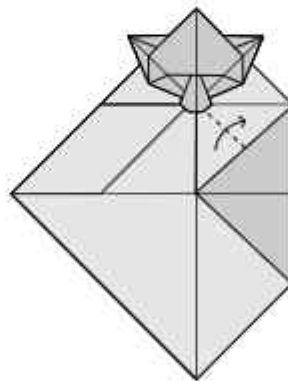

28. Pliegue en valle

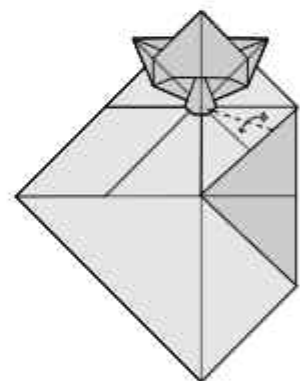

29. Doblar y desdoblar

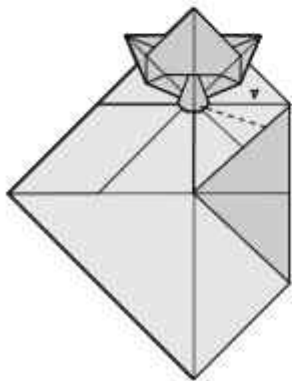

30. Hundir

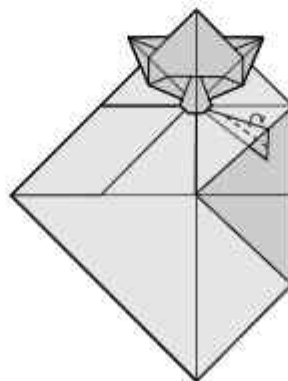

31. Pliegue montaña (las dos capas)

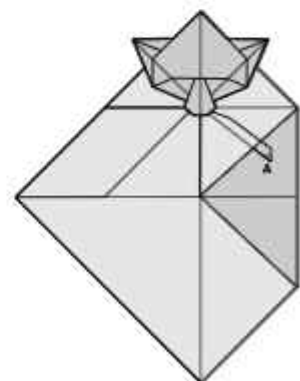

32. Hundir la punta

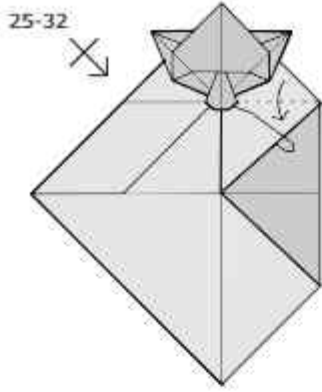

33. Bajar la solapa.
Repetir pasos 25 a 32

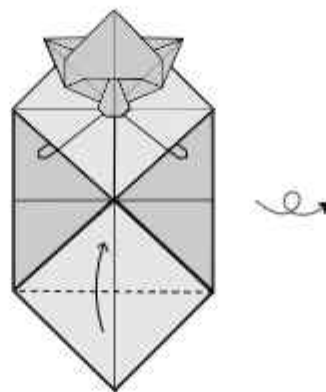

34. Pliegue en valle. Voltear

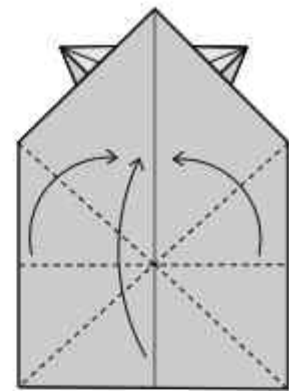

35. Base bomba de agua

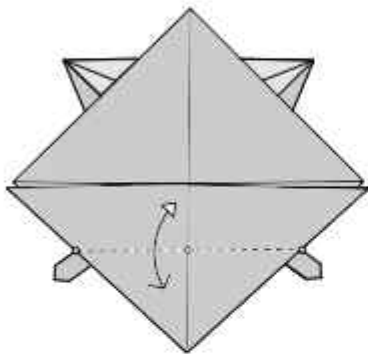

36. Doblar y desdoblar

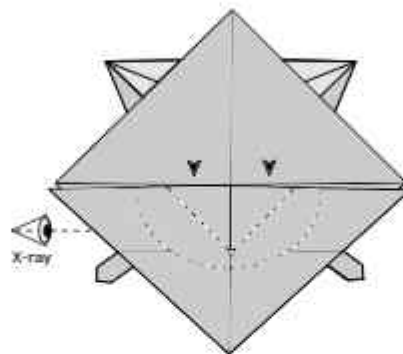

37. Revertir a 45°
en las capas interiores

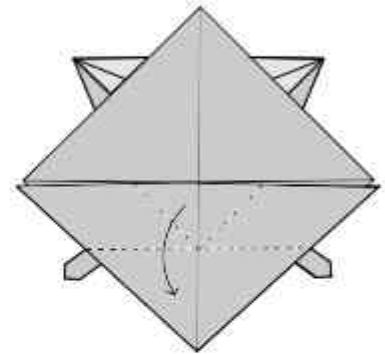

38. Pliegue en valle

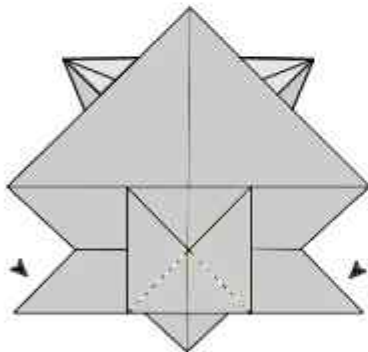

39. Revertir para bajar las piernas

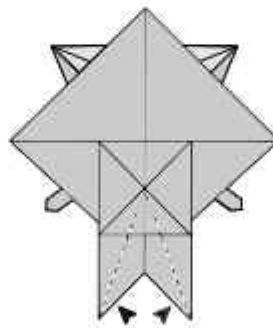

40. Revertir para perfilar
las piernas

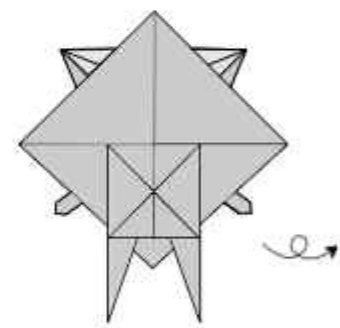

41. Voltear

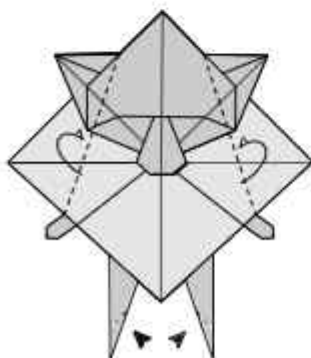

42 Pliegue en montaña.
Revertir para los pies

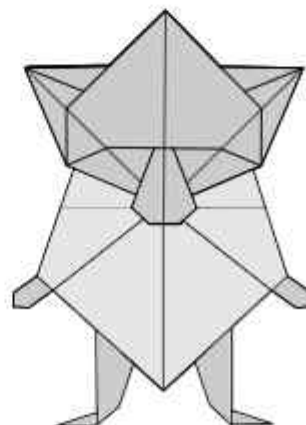

● LEONSZITO

● Creador: Eszti Györík

● Diagramas: Morgan Lozano

● Papel recomendado: Kami bicolor 20x20cm

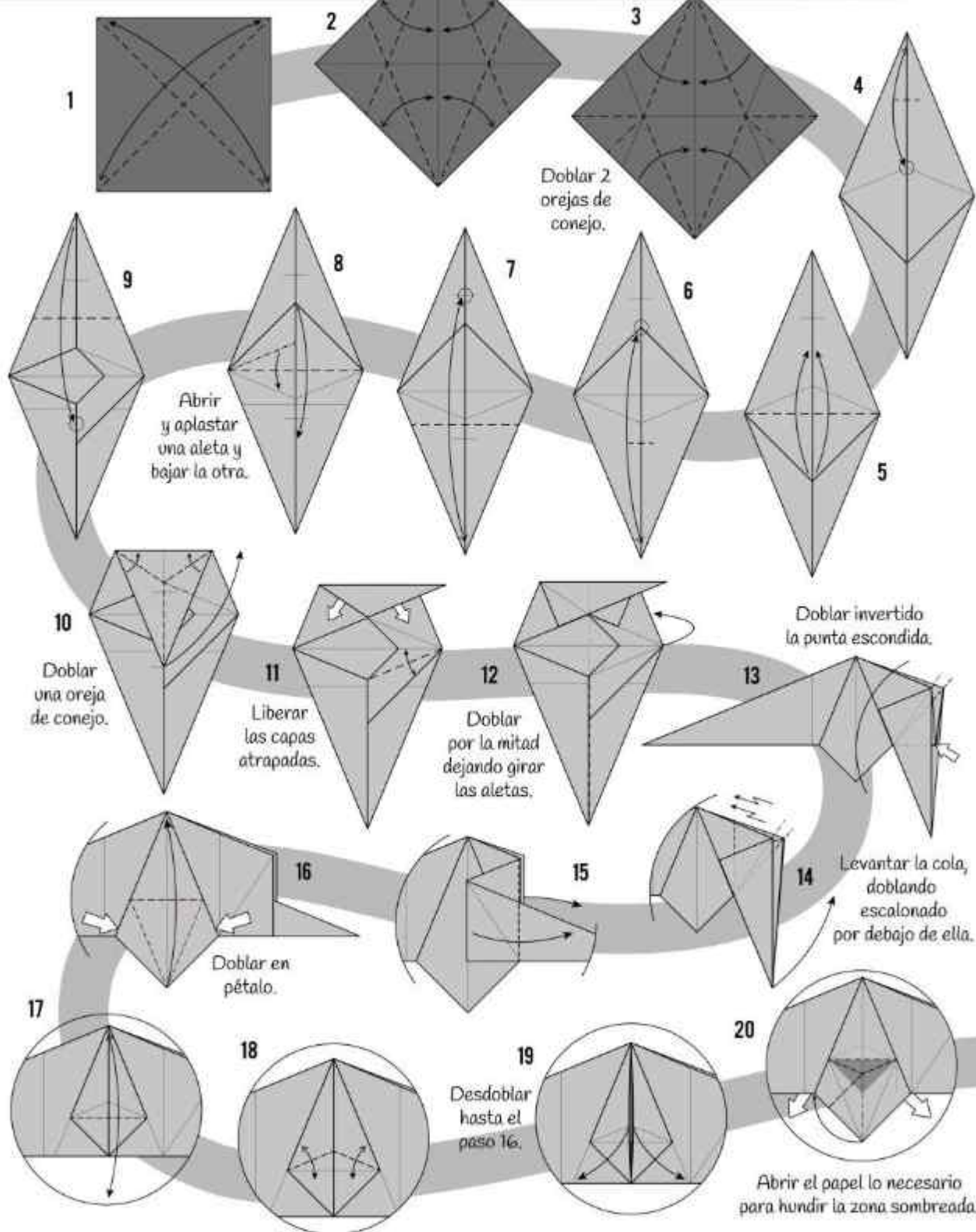

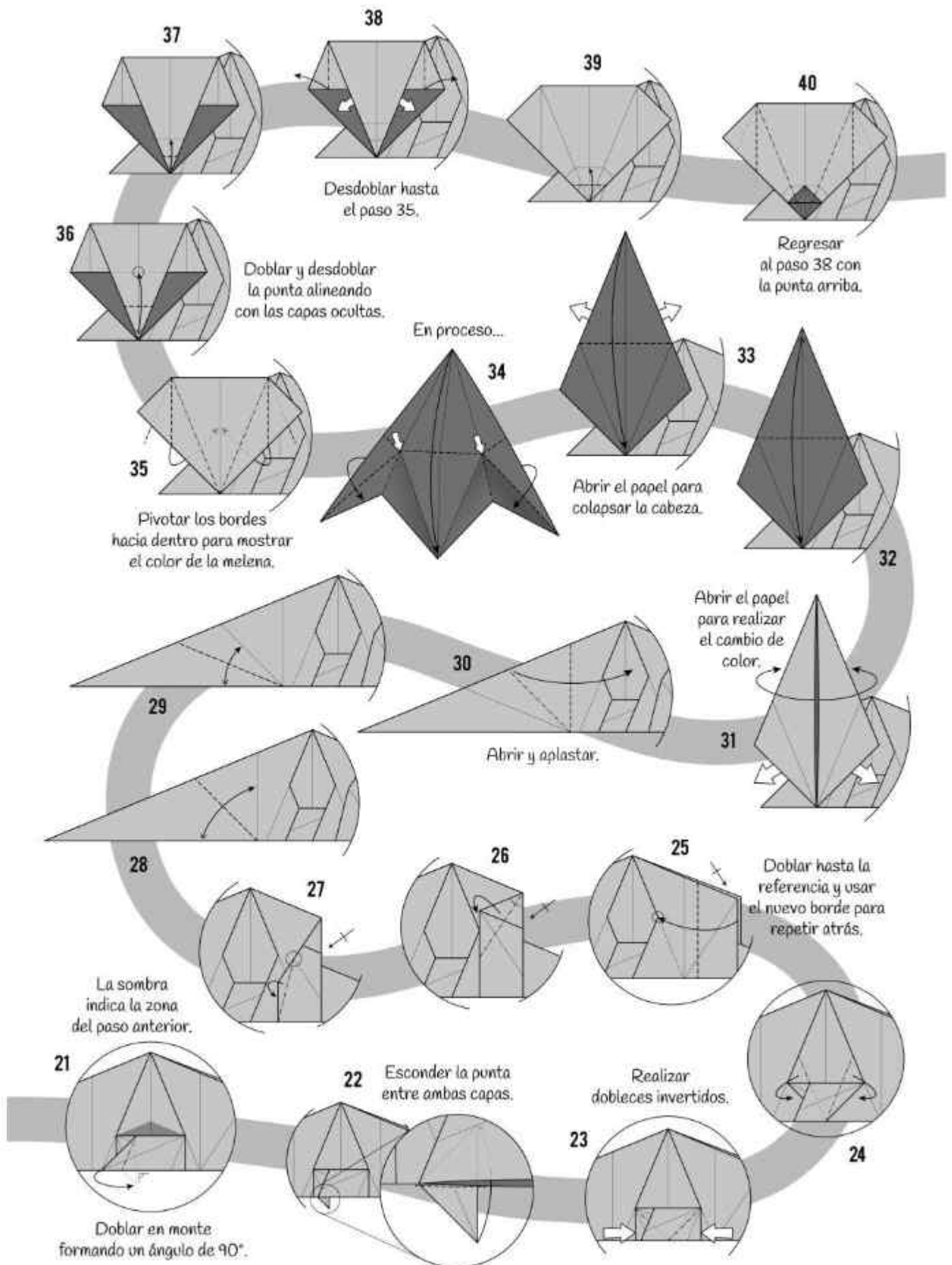

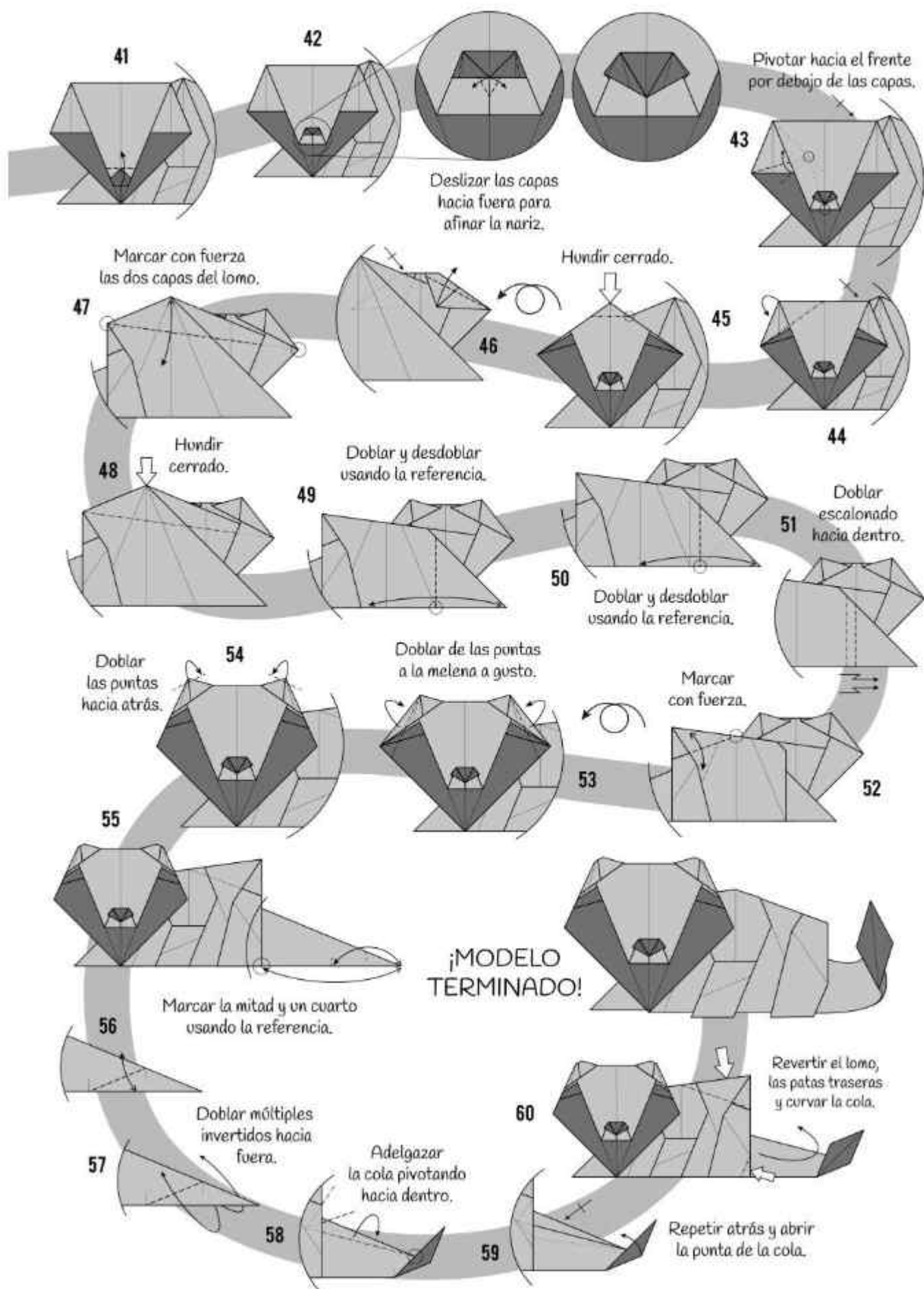

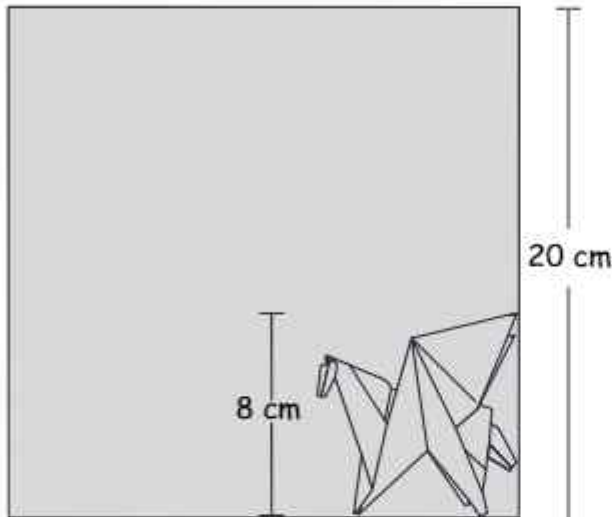

Pegaso Aleteador / Leonardo Pulido Martínez



Proporción: 0.4 : 1
(40% -100%)

Venadillo - Colombia
origamileo@gmail.com

Papel:	Tipo:	Cuadrado 
	Tamaño:	20 cm
	Color:	Monocolor /Bicolor 
Tiempo:	30 minutos	
Nivel:	Intermedio	
Tipo:	Origami Acción	
Fecha:	Enero 2021	

Esta es una variación del *Pegaso Aleteador V.1.0* presentado en el Tomo 2. Es un modelo relativamente sencillo y rápido de plegar, pero además es un modelo de acción muy entretenido y sus alas son muy funcionales.

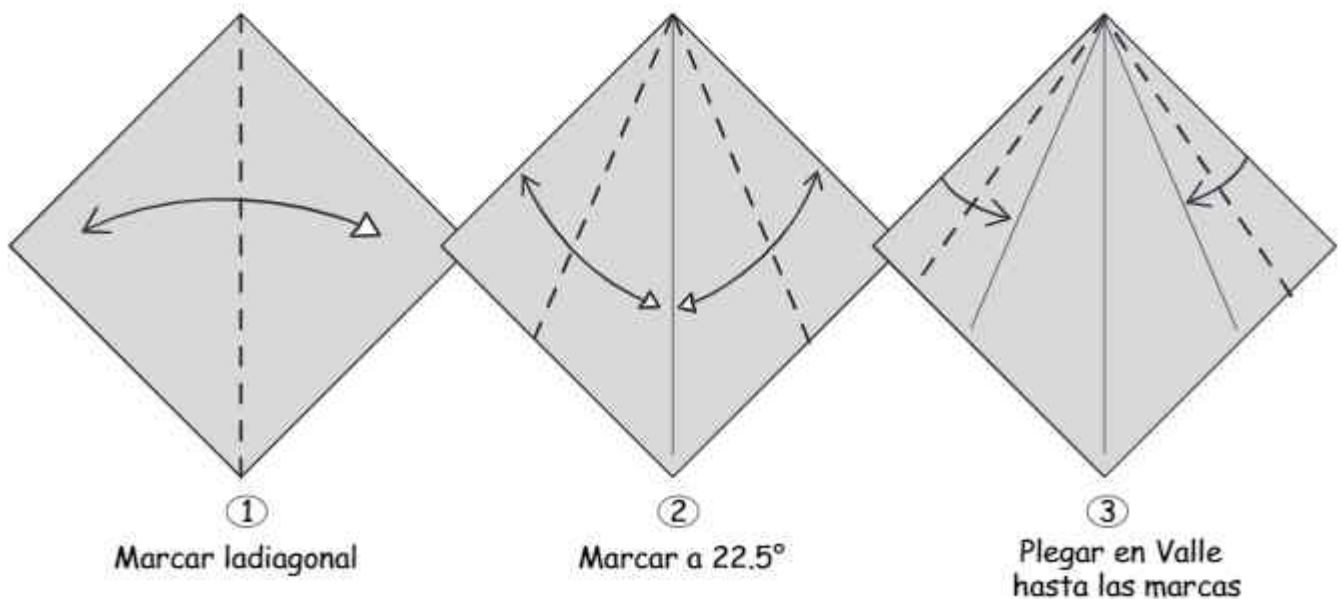

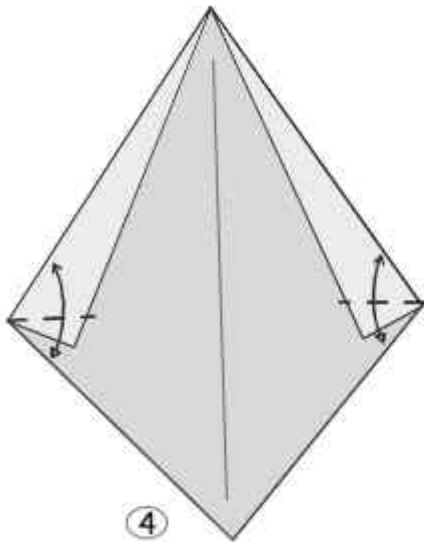

④

Marcar en Valle haciendo coincidir los bordes (biseccionar el ángulo)

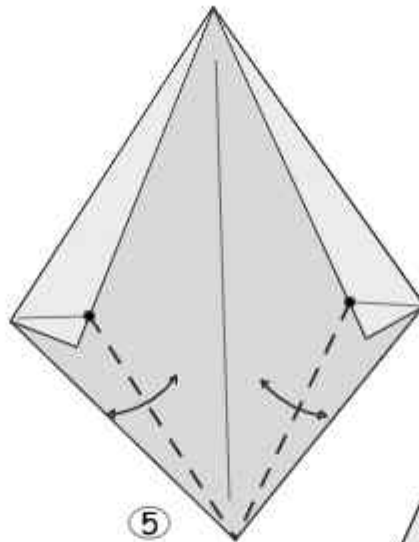

⑤

Marcar

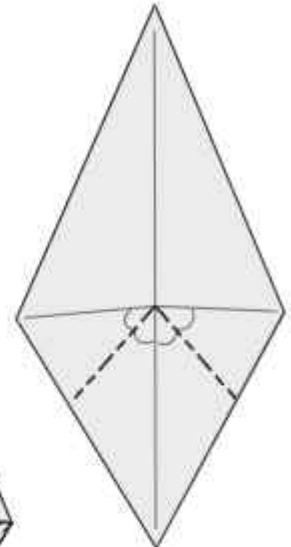

⑨

Marcar en Montaña biseccionando los ángulos

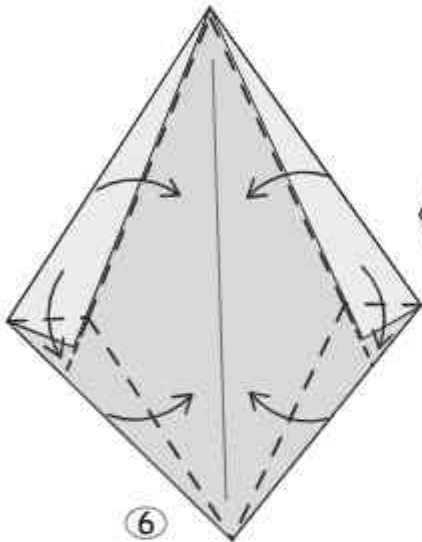

⑥

Plegar en oreja de conejo

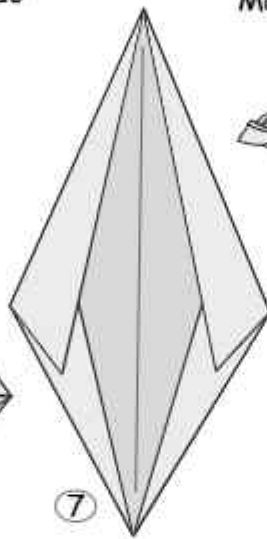

⑦

Dar la vuelta

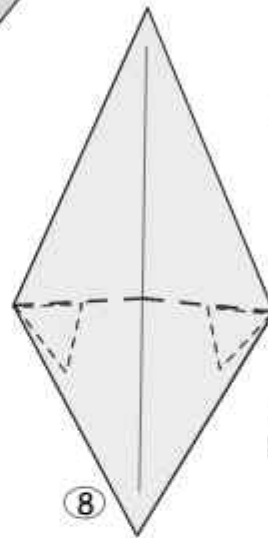

⑧

Marcar en Valle (usar las aletas traseras como guías)

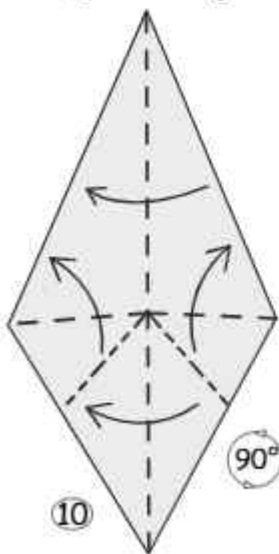

⑩

Plegar a manera de Base Bomba de Agua y rotar

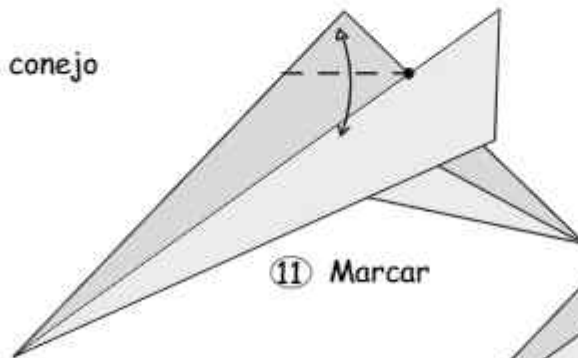

⑪

Marcar

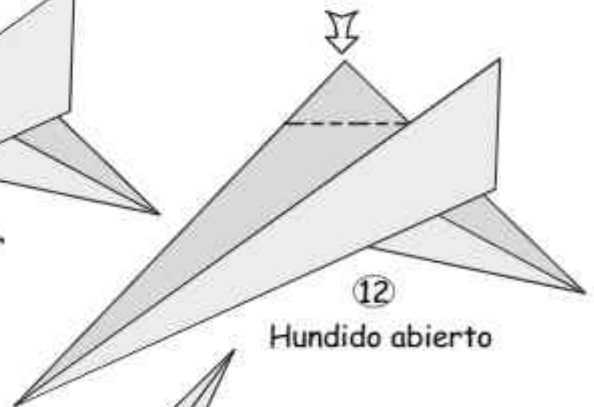

⑫

Hundido abierto

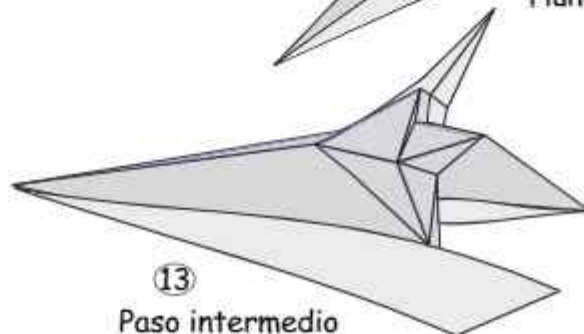

⑬

Paso intermedio

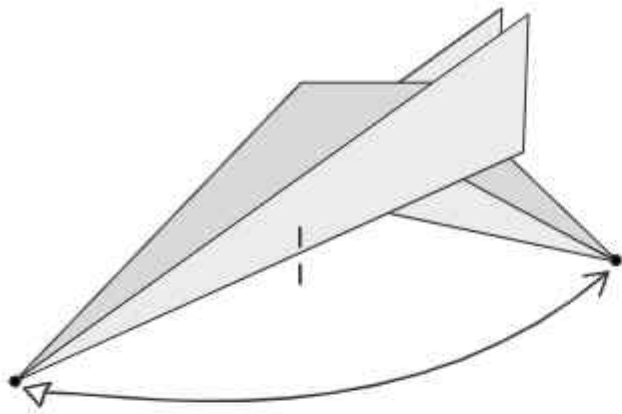

14 Pliegue pellizco

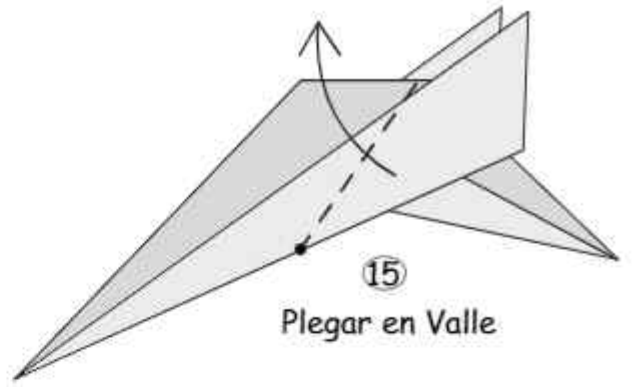

15
Plegar en Valle

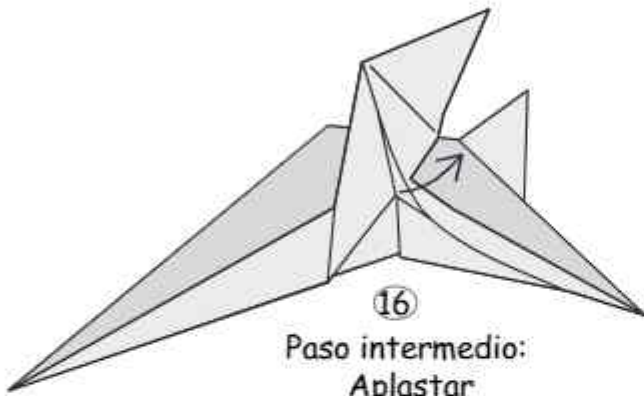

16
Paso intermedio:
Aplastar

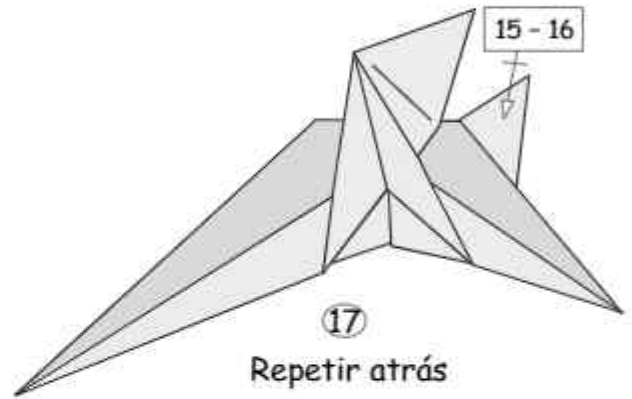

17
Repetir atrás

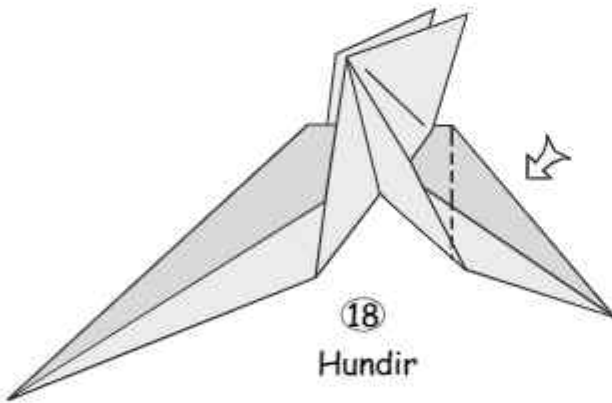

18
Hundir

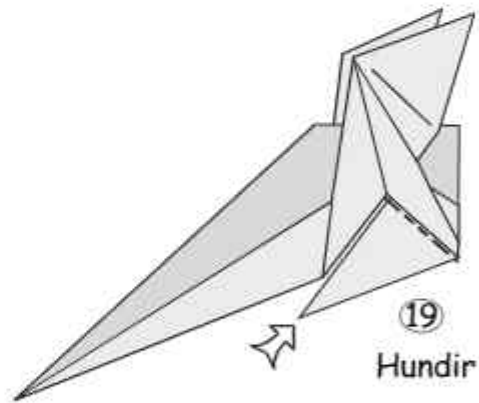

19
Hundir

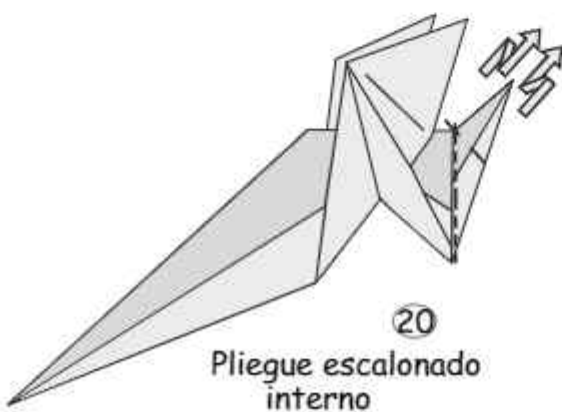

20
Pliegue escalonado
interno

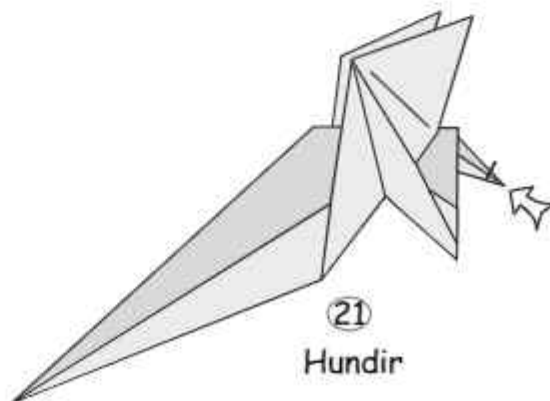

21
Hundir

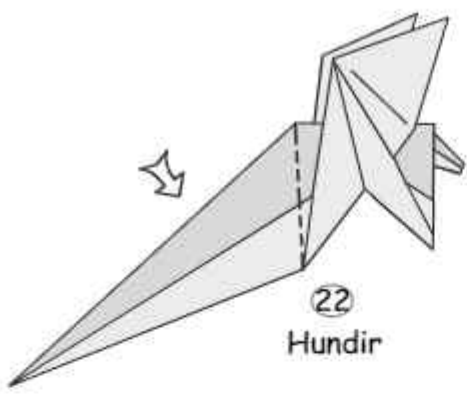

22
Hundir

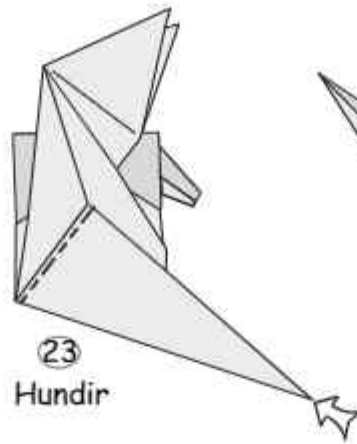

23
Hundir

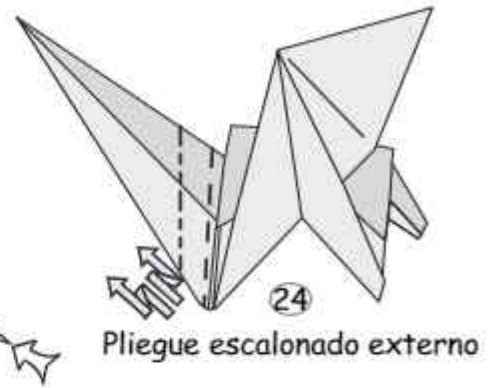

24
Pliegue escalonado externo

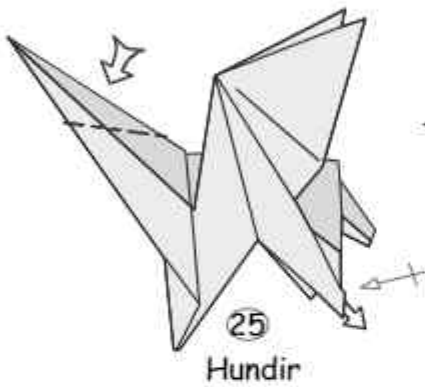

25
Hundir

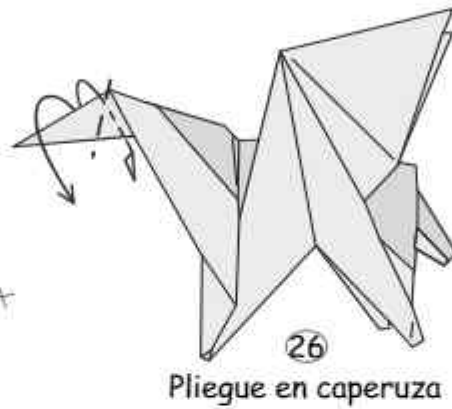

26
Pliegue en caperuza

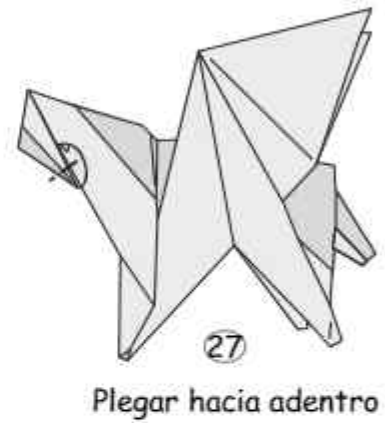

27
Plegar hacia adentro

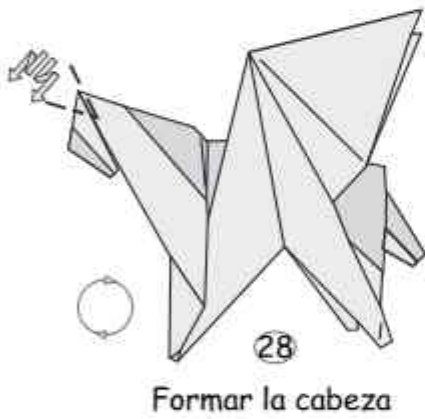

28
Formar la cabeza

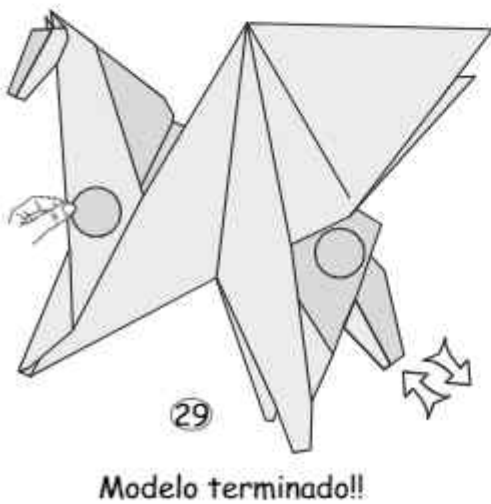

29
Modelo terminado!!

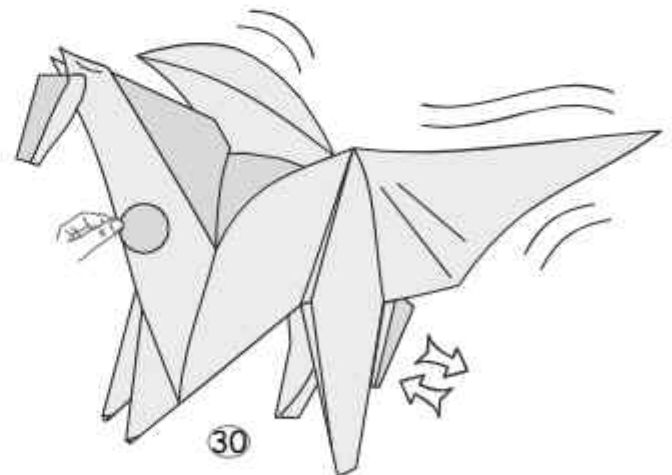

30
Sujetando como se muestray
halando la parte trasera,
el pegaso aleteará

Le Petit Ane / Christophe Boudias

min: 20x20cm => 8.5cm x 8cm.



Diagramme :
Christophe Boudias



1. Marquer les plis.

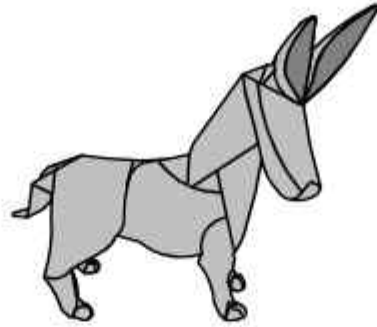
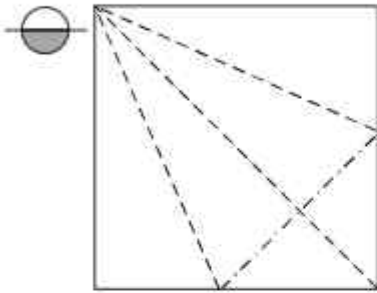
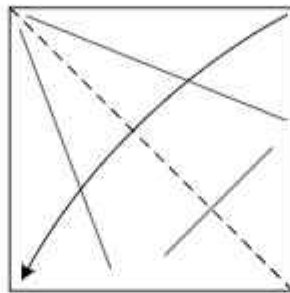

2. Plier suivant la diagonale.

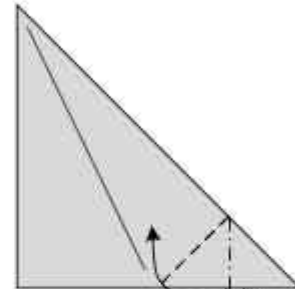

3. Pli aplati (Squash fold).

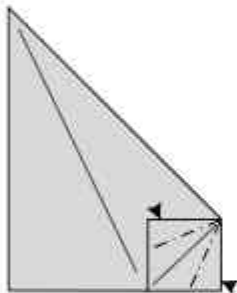

4. Rentrer les angles.

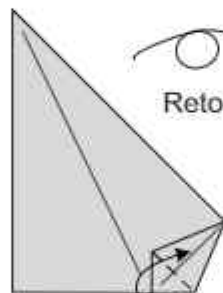

5. Pli vallée.

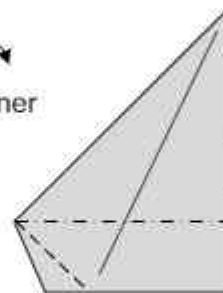

6. Pli pivot (45°)

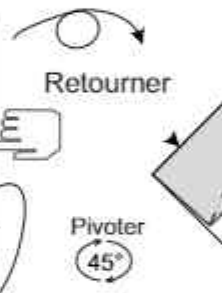

7. Rentrer les angles.

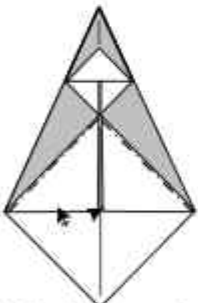

8. Rentrer les angles.

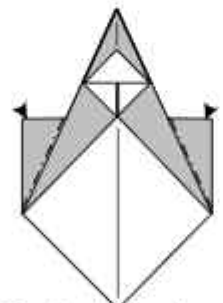

9. Rentrer les angles.

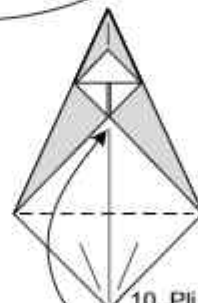

10. Pli vallée.



11. Marquer les bissectrices.

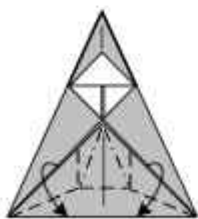

12. Plier vers le bas.

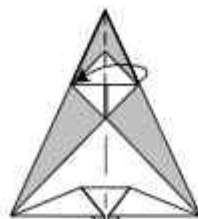

13. Plier vers la gauche.

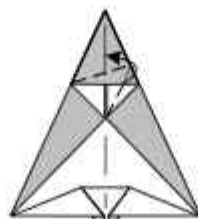

14. Pli pivot.

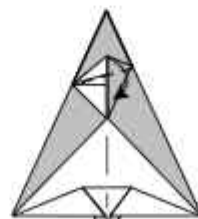

15. Pli vallée.

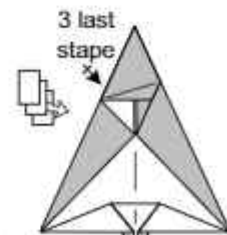

16. Répéter les étapes 13 à 15 côté gauche.

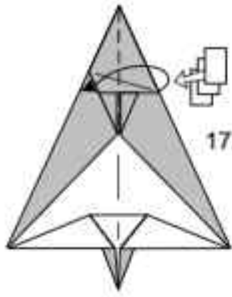

17. Plier vers la gauche.

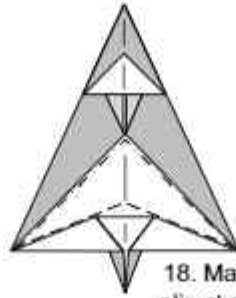

18. Marquer les plis et retourner.

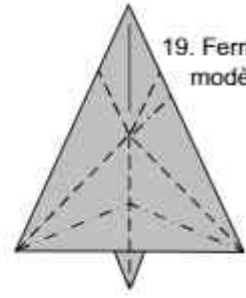

19. Fermer le modèle.

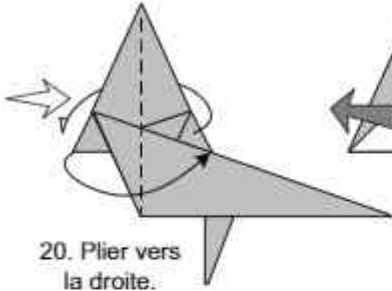

20. Plier vers la droite.

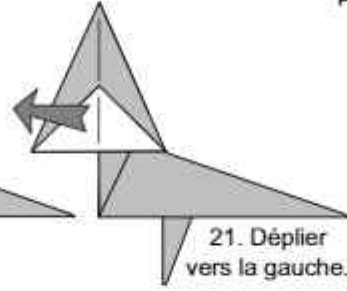

21. Déplier vers la gauche.

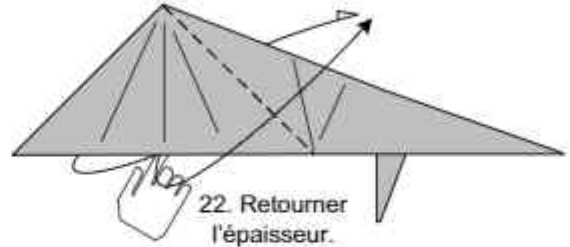

22. Retourner l'épaisseur.

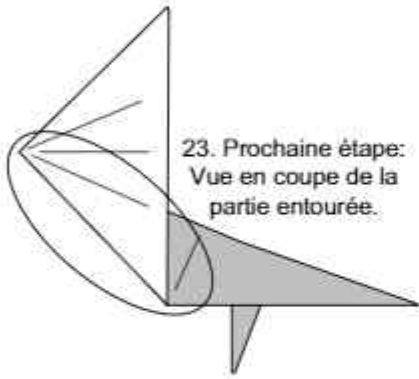

23. Prochaine étape: Vue en coupe de la partie entourée.

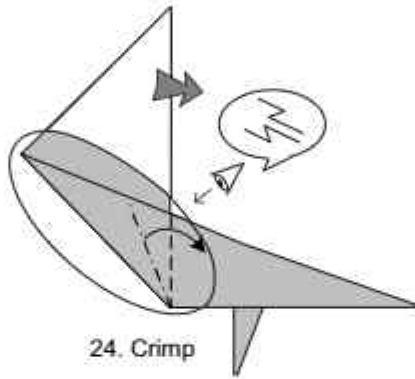

24. Crimp

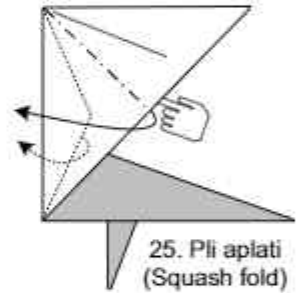

25. Pli aplati (Squash fold)

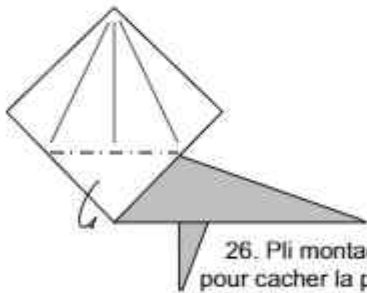

26. Pli montagne pour cacher la pointe.

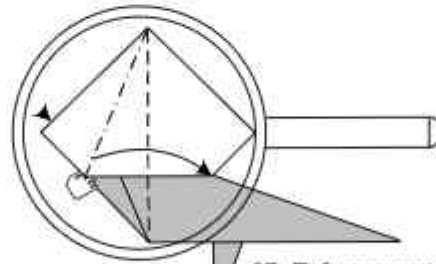

27. Enfoncement de l'aile gauche, pli aplati (Squash fold)

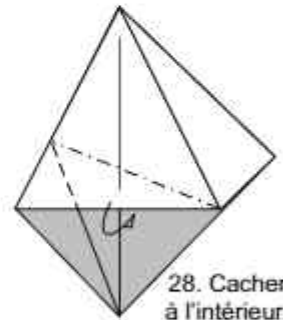

28. Cacher à l'intérieur.

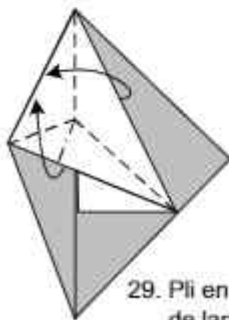

29. Pli en oreille de lapin.

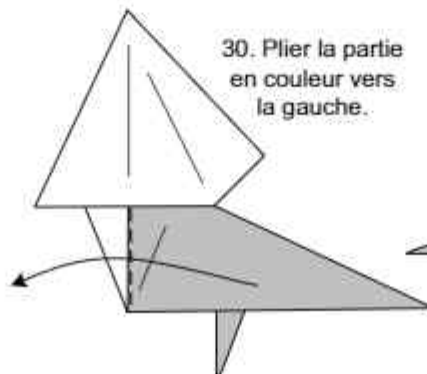

30. Plier la partie en couleur vers la gauche.

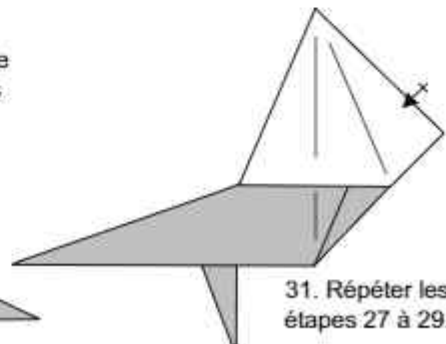

31. Répéter les étapes 27 à 29.

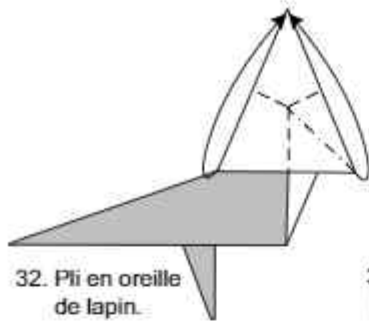

32. Pli en oreille de lapin.

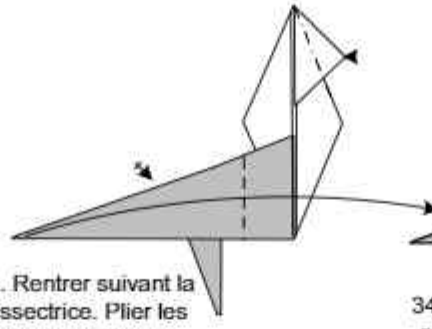

33. Rentrer suivant la bissectrice. Plier les pattes vers l'avant.

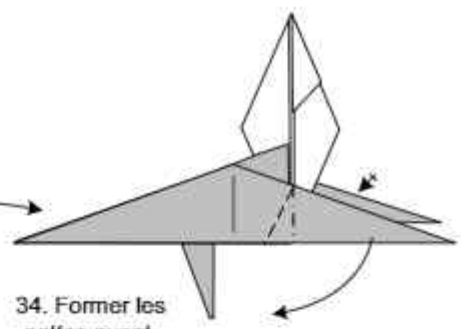

34. Former les pattes avant.

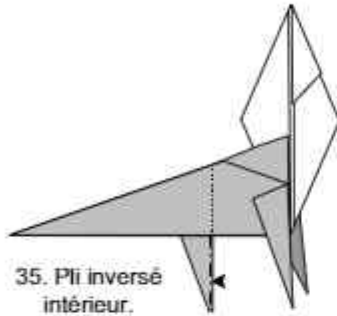

35. Pli inversé intérieur.

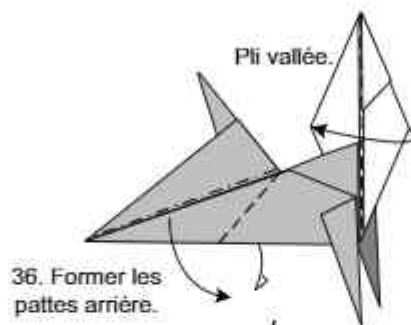

36. Former les pattes arrière.

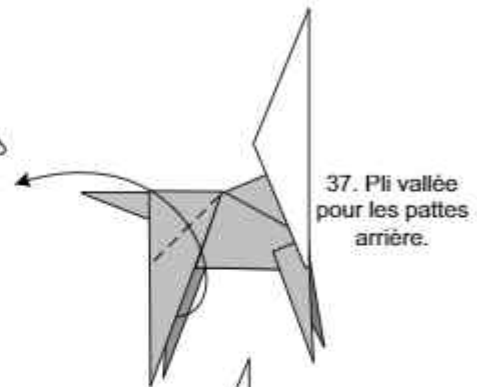

37. Pli vallée pour les pattes arrière.

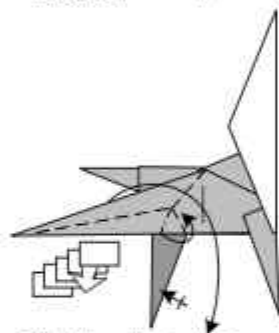

38. Pli oreille de lapin pour l'intérieur des pattes arrière. Répéter les étapes 37-38 sur l'autre patte.

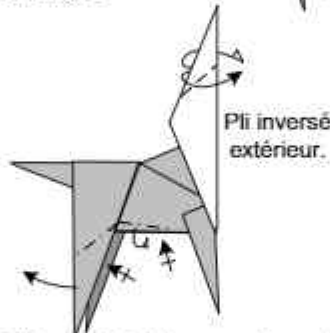

39. Pli inversé intérieur pour les pattes arrière. Pli montagne pour la couche supérieure de papier du ventre.

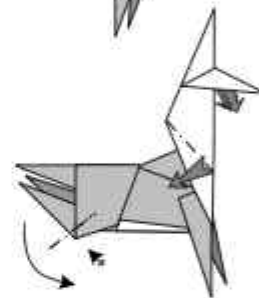

40. Pli inversé intérieur pour les pattes arrière. Sortir des épaisseurs de la tête, ouvrir le cou.

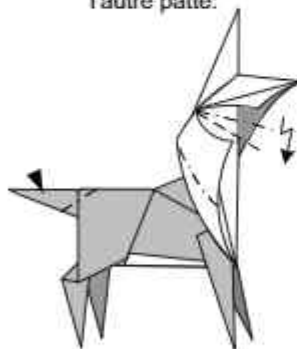

41. Pli inversé intérieur pour la queue. Pli zig-zag entre les épaisseurs du cou.

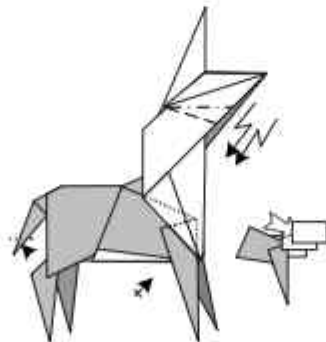

42. Pli inversé intérieur pour la queue. Crimp pour former la tête. Passer les épaules entre les épaisseurs du cou.

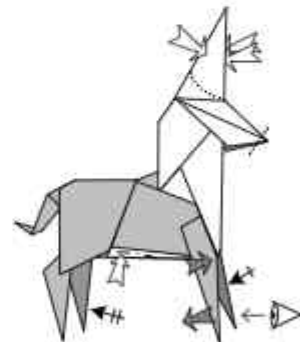

43. Ouvrir les oreilles. Former les sabots.

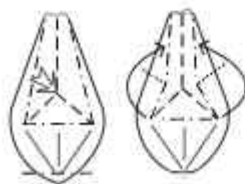

Former les sabots.



Le petit âne est terminé !



Conejo / Francesco Massimo

Designed / Diseño: 03/2021

Level: Intermediate
/ Nivel: Intermedio

Double-colored paper: Yes
/ Papel con doble color: Sí.

Recommended paper
/ Papel recomendado:
< 70 gsm, > 25 cm x 25 cm



Ratio: 0.5

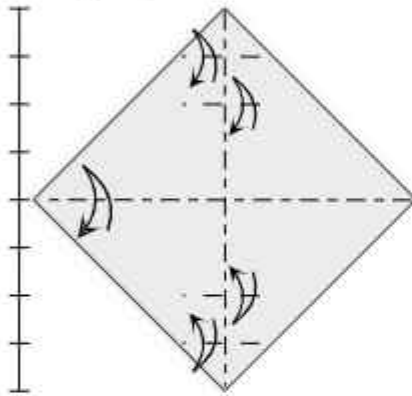
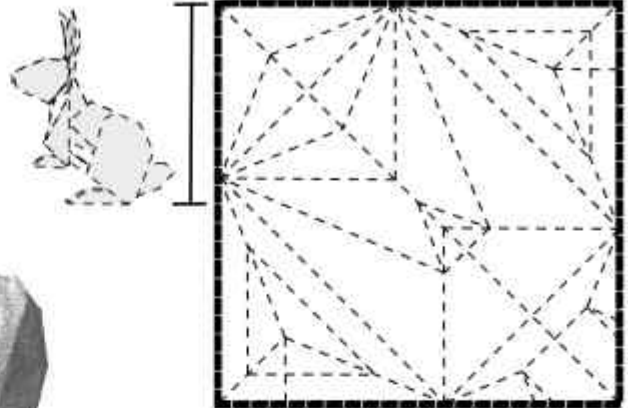

1. Fold and unfold the diagonals and the shown reference creases.
Doblar y desdoblar las diagonales y los pliegues de referencia mostrados.

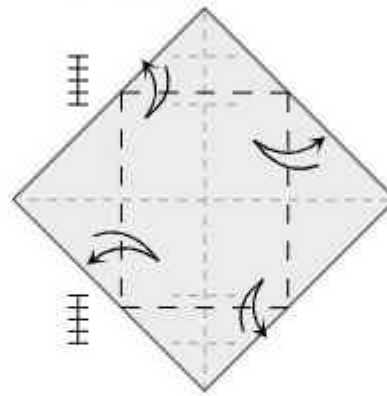

2. Fold and unfold the horizontal reference creases. Then, join their endpoints with vertical creases.
Doblar y desdoblar los pliegues de referencia horizontales, Después, unir sus extremos con pliegues verticales.

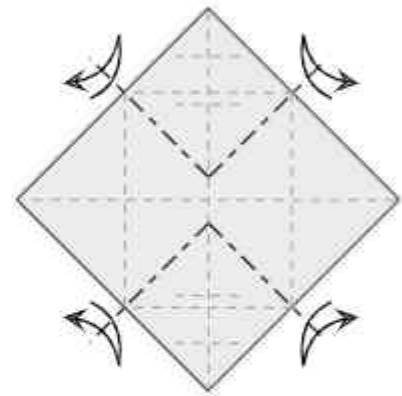

3. Fold and unfold 45° creases from the angles of the rectangle formed in the last step.
Doblar y desdoblar pliegues a 45° desde los ángulos del rectángulo formado en el paso precedente.

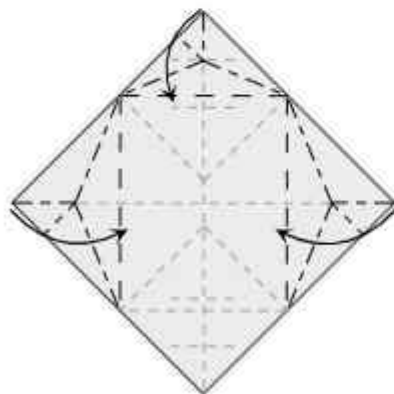

4. Fold a half Fish Base with the lateral triangles and with the top triangle.
Doblar una mitad de BasePez con cada triángulo lateral y con el triángulo arriba.

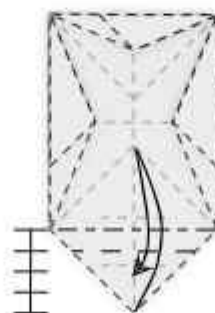

5. Fold the tip up and down following the reference creases. Then, turn the model over.
Doblar la punta arriba y abajo siguiendo los pliegues mostrados. Después, dar vuelta al modelo.

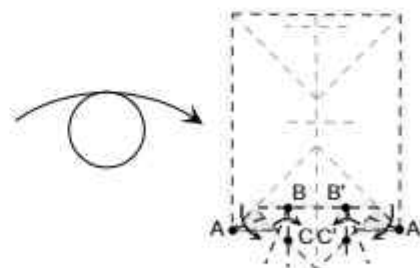

6. Form the tail: valley-fold AB and A'B' at 22.5°. Then, valley-fold the vertical lines BC and B'C'.
Formar la cola: doblar en valle AB y A'B' a 22.5°. Después, doblar en valle las líneas verticales BC y B'C'.

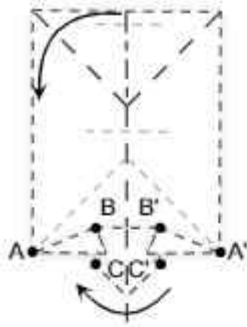

7. Fold along some existing creases and collapse.
Doblar usando unas de los pliegues existentes y colapsar.

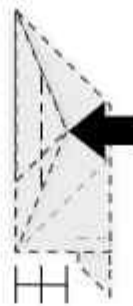

8. Open-sink one of the lateral half Fish Bases of step 4 at half its height. Repeat behind.
Hundir una de las mitades de Base Pez laterales del paso 4 desde mitad de su altura. Repetir atrás.



9. Fold and unfold.
Then, reopen the model up to step 7 without reopening the creases of step 8.
Doblar y desdoblar. Después, reabrir el modelo hasta el paso 7 sin reabrir los pliegues del paso 8.

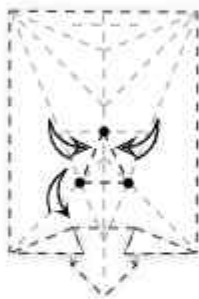

10. Join the marked intersection points with creases as shown, folding and unfolding.
Unir los puntos de intersección marcados con pliegues como mostrado, doblando y desdoblando.

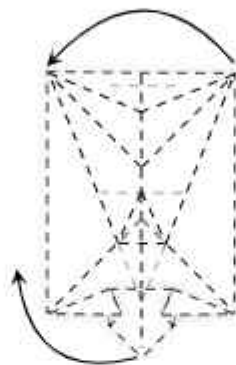

11. Collapse using some of the existing creases.
Colapsar usando unos de los pliegues existentes.



12. Reverse the tail and incline the rear legs downwards joining the two shown reference points with a crease.
Invertir la cola y inclinar las patas posteriores abajo uniendo los dos puntos de referencia mostrados con un pliegue.

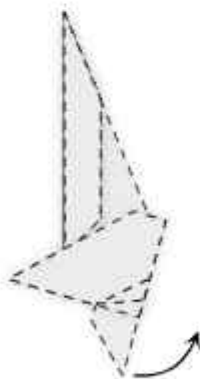

13. Bring the tail upwards.
Llevarla cola arriba.

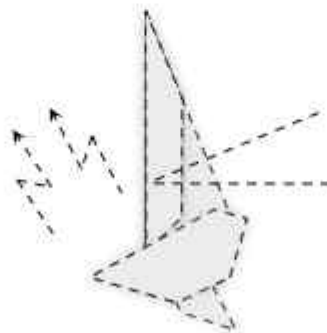

14. Pleat at the front legs' base to form the neck. There is an odd number of layers: just fold the central one on one side.
Doblar en zigzagla base de las patas anteriores para formar el cuello. Hay un numero impar de capas: doblar la central a uno de los dos lados.

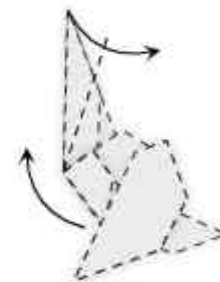

15. Fold the front legs towards the head and the ears towards the back.
Doblar las patas anteriores hacia la cabeza y las orejas hacia la espalda.



16. Change the color of the belly.
Cambiar el color del vientre.



17. Narrow the belly and flatten. Fold neatly the innermost hidden layer of the rear legs as you wish.
Adelgazar el vientre y aplastar. Doblar ordenadamente la capa oculta más interior de las patas posteriores cómo quieras.

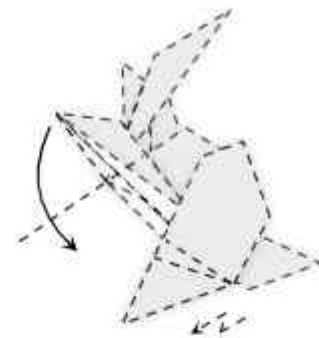

18. Fold down the front legs, pulling out some paper from the junction with the neck. Form the rear legs.
Doblar abajo las patas anteriores, sacando un poco de papel desde la unión con el cuello. Formar las patas posteriores.

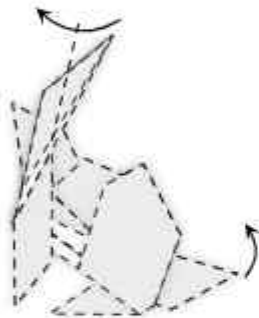

19. Fold the ears upwards. Incline the tail upwards.
Doblar las orejas arriba. Inclinar la cola arriba.

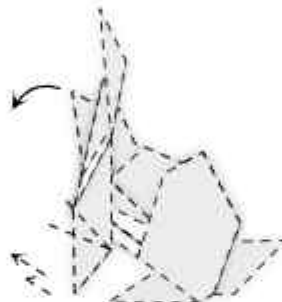

20. Pull out the paper of the head. Fold upwards the front legs.
Sacarel papel de la cabeza. Doblar arriba las patas anteriores.

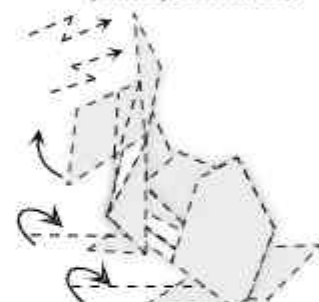

21. Form the head and shape the legs.
Formar la cabeza y moldear las patas.

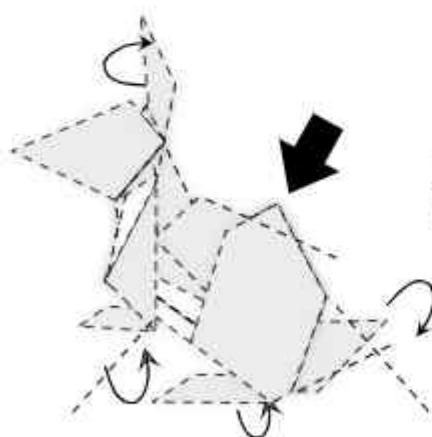

22. Open the ears, round the elbows, the back and the tail.
Abrir las orejas, redondear los codos, la espalda y la cola.

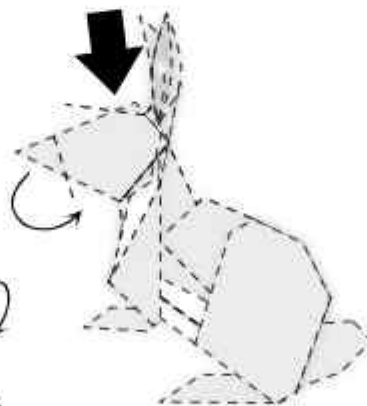

23. Open-sink some paper from the forehead. Reverse-fold the tip of the head and the junction with the ears.
Hundir un poco de papel de la frente. Invertir la punta de la cabeza y la unión con las orejas

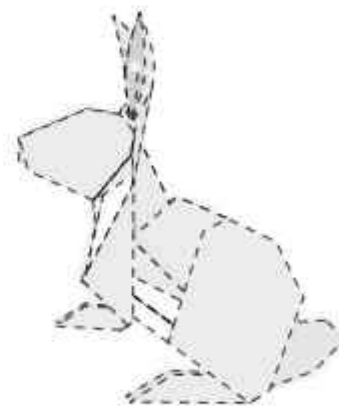

24. Finished model.
Modelo terminado.

Ardilla / Francesco Massimo

Designed
/ *Diseño:*
04/2021

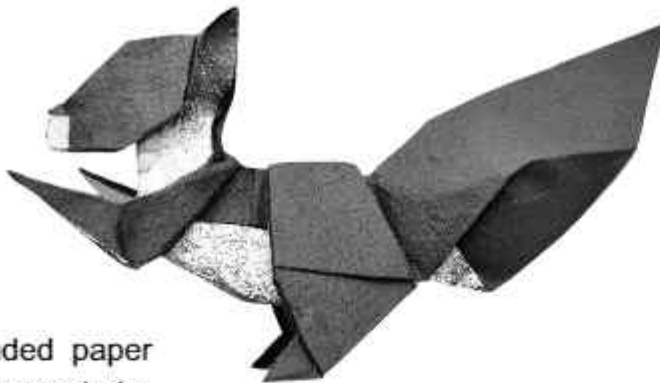

Recommended paper
/ *Papel recomendado:*
40-60 gsm, > 25 cm x 25 cm
Double colored paper: Yes / *Papel doble color:* Sí
Level: intermediate / *Nivel:* intermedio.

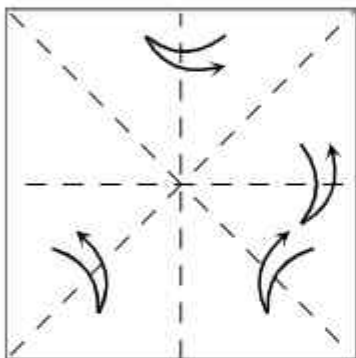
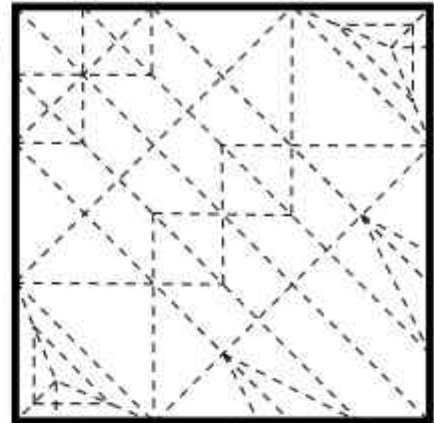

1. Fold and unfold along the diagonals and the medians.
Doblar y desdoblar las diagonales y las medianas.

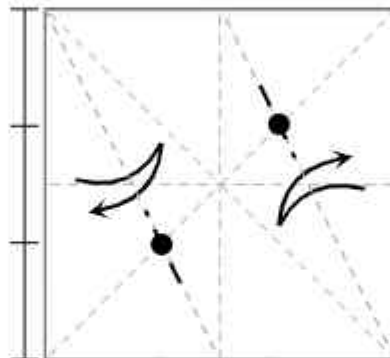

2. Fold and unfold joining the reference points to divide the square side in three.
Doblar y desdoblar unendo los puntos de referencia, dividiendo los lados del cuadrado en tres

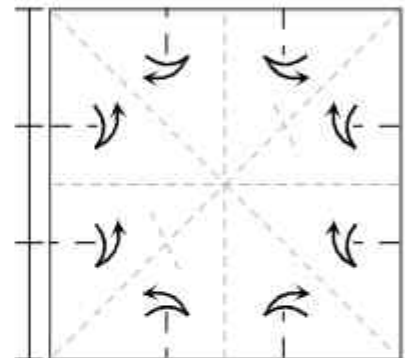

3. Fold and unfold to mark the 1/3 and 2/3 of the square sides as reference.
Doblar y desdoblar marcando 1/3 y 2/3 de los lados del cuadrado como referencia.

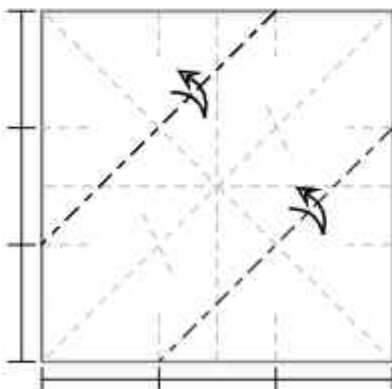

4. Fold and unfold to join the reference points found in the previous step.
Doblar y desdoblar unendo los puntos de referencia del paso precedente.

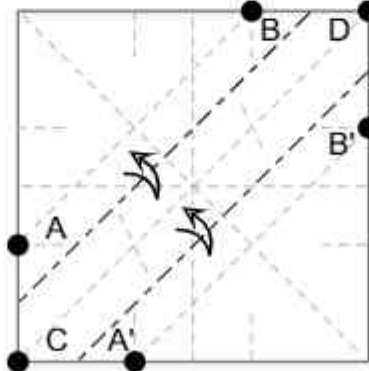

5. Fold and unfold superimposing lines AB and A'B' to CD.
Doblar y desdoblar sobreponiendo las líneas AB y CD.

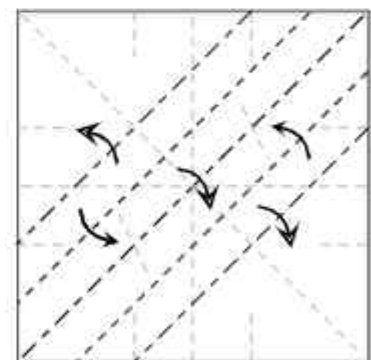

6. Collapse using creases from the previous steps.
Colapsar usando los pliegues de los pasos precedentes.

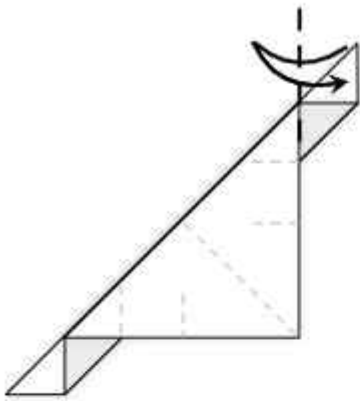

7. Fold and unfold along the shown line. Then, reopen the model.
Doblar y desdoblar la línea marcada. Después, reabrir el modelo.

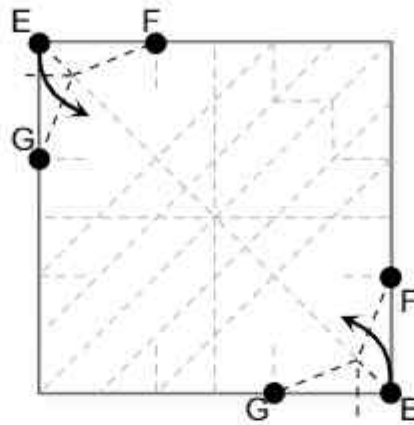

8. Form two half Fish Bases from the triangles EFG.
Formar dos medias BasesPez con los triángulos EFG.

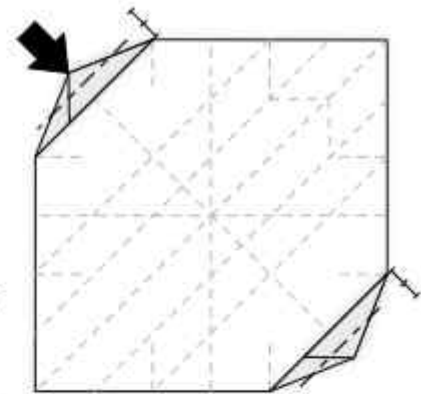

9. Open sink the half Fish Bases at half their height.
Hundir las medias BasesPez a mitad de sus alturas.

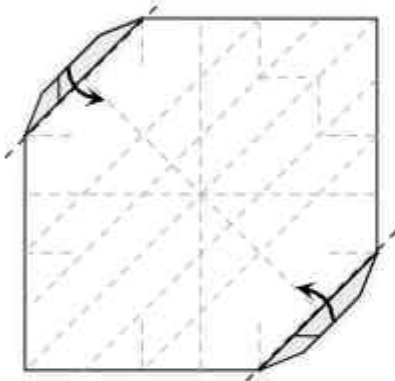

10. Fold the sinked half Fish Bases towards the diagonal.
Doblar las dos medias BasesPez hundidas de los pasos precedentes hacia la diagonal.

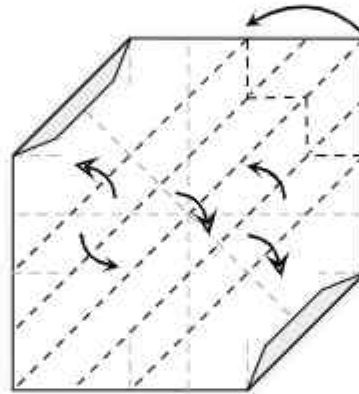

11. Collapse, using the creases of the previous steps, reversing some of their portions.
Colapsar, usando los pliegues de los pasos precedentes, invirtiendo unas de sus porciones.

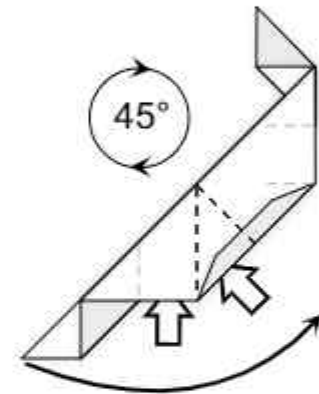

12. Open and squash. Then, rotate the model by 45°.
Abrir y apiastar. Después, girar el modelo de 45°.

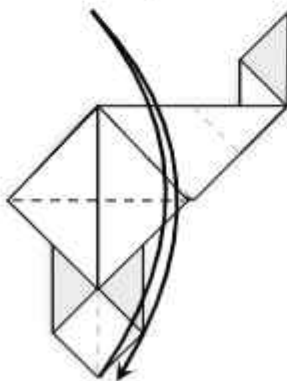

13. Fold and unfold the tail flap upwards.
Doblar y desdoblar la aleta de la cola arriba.

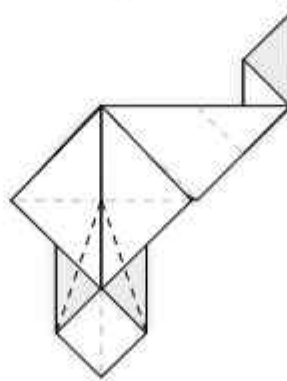

14. Open a little bit the tail flap.
Abrir un poco la aleta de la cola.

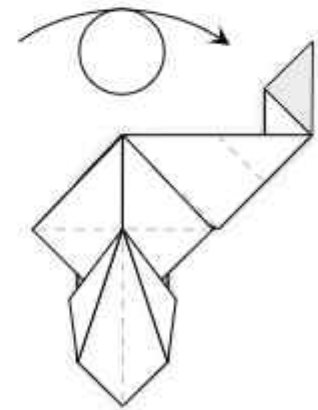

15. Turn the model over.
Dar vuelta al modelo.

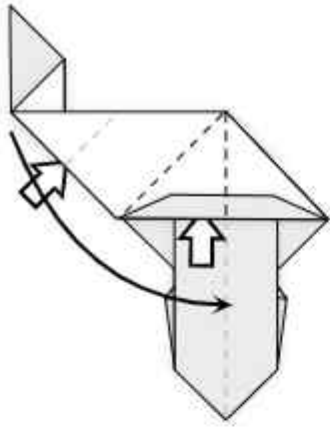

16. Open and squash.
Abrir y aplastar.

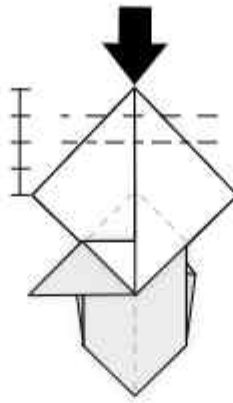

17. Double-open sink.
Hundir dos veces.

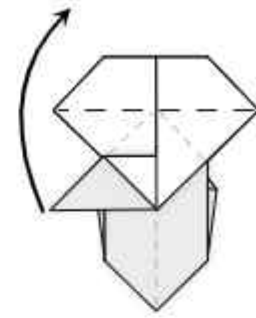

18. Fold the head flap upwards.
Doblar arriba la aleta de la cabeza.

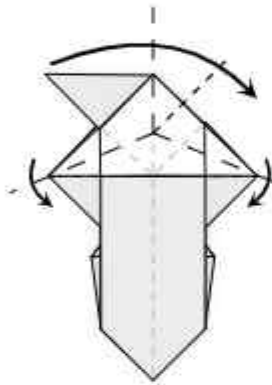

19. Rabbit-ear fold.
Doblar una oreja de conejo.

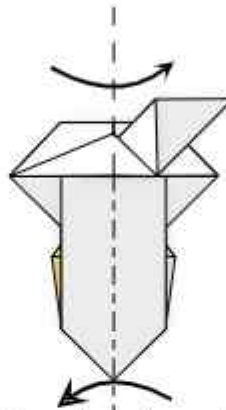

20. Fold one layer towards right and repeat behind.
Doblar una capa a derecha y repetir atrás.

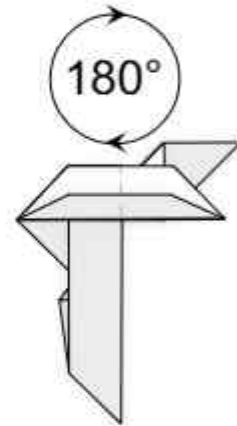

21. Rotate the model by 180°.
Girar el modelo de 180°.

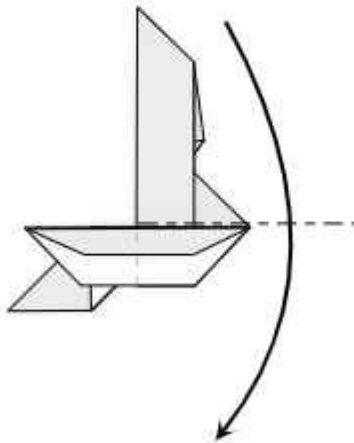

22. Fold down the tail flap.
Doblar abajo la aleta de la cola.

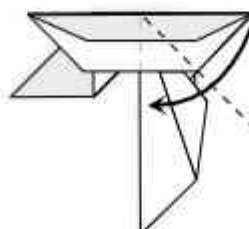

23. Fold down the rear legs.
Doblar abajo las patas posteriores.



24. Bring the tail flap upwards. Bring the head flap upwards, making the line HI vertical, and flatten.
LLevarla aleta de la cola arriba. LLevarla aleta de la cabeza arriba, la línea HI debe volverse vertical. Después, aplanar.

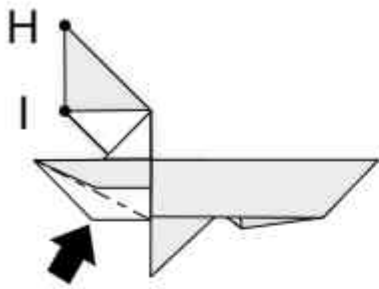

25. Narrow the front legs with an open sink for each one.
Adelgazar las patas anteriores con un hundido en cada una.

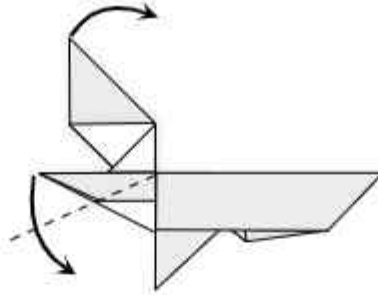

26. Fold down the front legs, pulling the head a little bit towards the tail, and flatten.
Doblar abajo las patas anteriores, tirando un poco la cabeza hacia la cola, y aplanar.

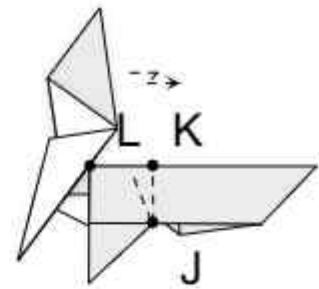

27. Fold and unfold the vertical line JK. Then, fold and unfold superimposing lines JK and JL.
Doblar y desdoblar la línea vertical JK. Después, doblar y desdoblar sobreponiendo las líneas JK y JL.

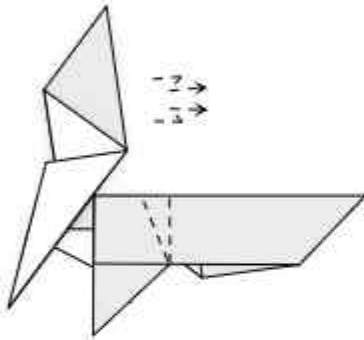

28. Fold the tail upwards using the creases made in the previous step.
Doblar la cola arriba usando los pliegues del paso precedente.

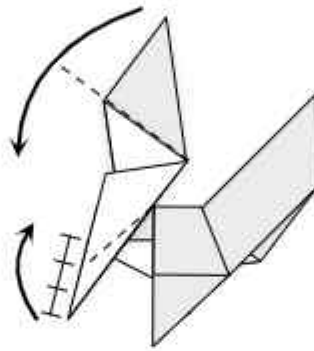

29. Fold the front legs upwards. Reverse the head tip.
Doblar arriba las patas anteriores. Invertir la punta de la cabeza.

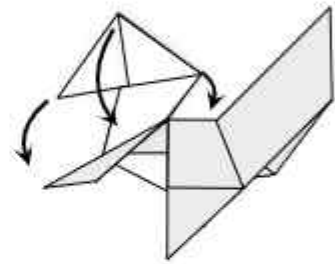

30. Pull the head tip towards left and at the same time fold down the lateral borders of the head, opening the ears.
Tirar la punta de la cabeza hacia izquierda y al mismo tiempo doblar abajo los bordes laterales de la cabeza, abriendo las orejas.

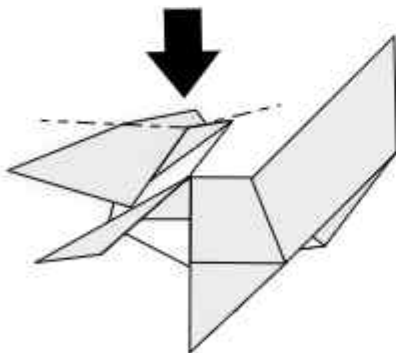

31. Result of the previous step. The head will be three-dimensional. Open-sink the top part of the head.
Resultado del paso precedente. La cabeza será tridimensional. Hundir la parte más alta de la cabeza.

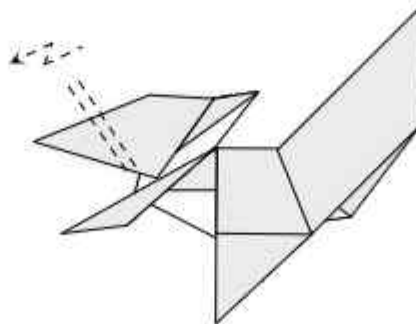

32. Pleat the head. There are no precise references for these folds.
Doblar en zigzag la cabeza. No hay referencias precisas por estos pliegues.

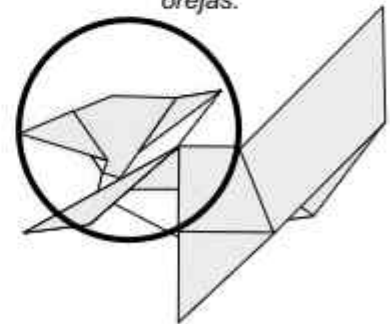

33. The next steps will focus on the head.
Los próximos pasos se concentrarán sobre la cabeza.

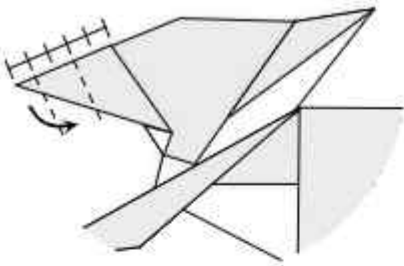

34. Form the color change of the nose.
Formar el cambio de color de la nariz.

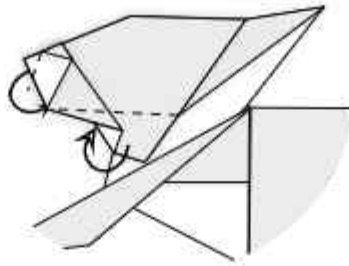

35. Narrow the head.
Fold inside some paper between the nose and the mouth.
Adelgazar la cabeza.
Doblar adentro un poco de papel entre la nariz y la boca.

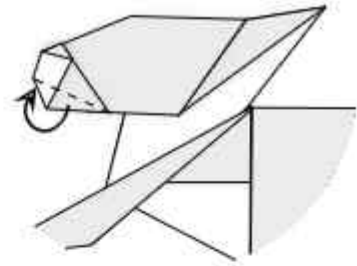

36. Narrow the jawline.
Adelgazar la mandíbula.

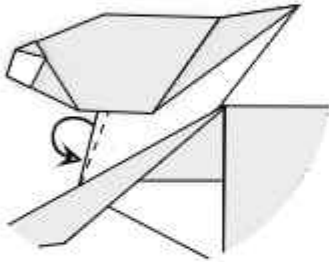

37. Fold inside some paper to narrow the neck.
Now we will go back working on the entire model.
Doblar adentro un poco de papel para adelgazar el cuello.
Ahora volveremos a trabajar sobre el modelo entero.

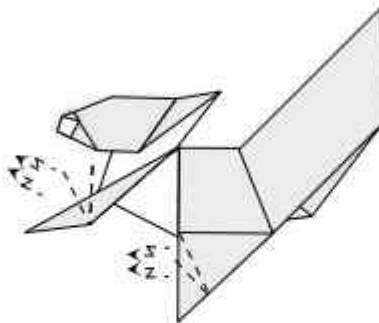

38. Form the arms and the feet.
Formar los brazos y los pies.

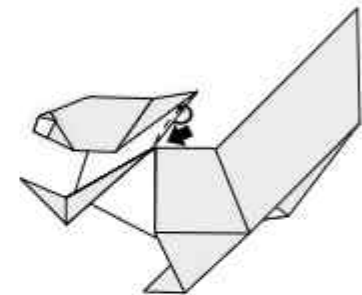

39. Slightly open the ears and shape them.
Sink some paper in the upper part of the neck if necessary
Abrir un poco las orejas y moldearlas.
Hundir un poco de papel de la parte alta del cuello si necesario.

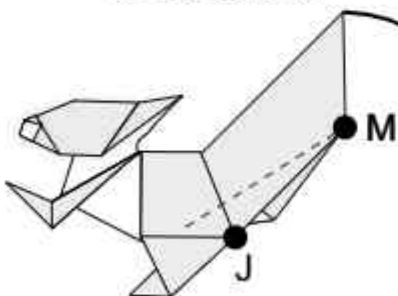

40. Pinching point J from the two sides, inflate the tail pushing out the hidden red valley fold from inside. Repeat behind.
Pellizcando el punto J desde los dos lados, inflar la cola empujando fuera el pliegue en valle rojo ocultado desde el interior.

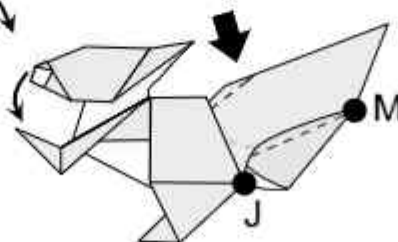

41. Result of the previous step. Note how line JM was curved. Shape the head.
(Optional) Push inside the higher part of the tail's base.
Resultado del paso precedente.
Notar como la línea JM se curvó.
Moldear la cabeza.
(Opcional) *Hundir un poco la parte alta de la base de la cola.*

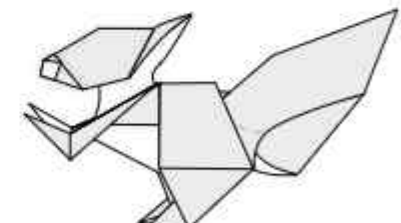

42. Finished model.
Modelo terminado.

Sea Horse / Leonardo Pulido Martínez

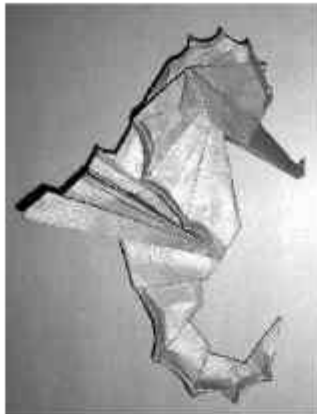

Venadillo - Colombia
origamileo@gmail.com

Paper:	Type:	Square <input type="checkbox"/>
	Size:	20 cm Recommended
	Color:	Single Color <input type="checkbox"/>
Time:	40 minutes	<input checked="" type="checkbox"/>
Level:	Intermediate	<input checked="" type="checkbox"/>
Date:	April 2020	<input type="checkbox"/>

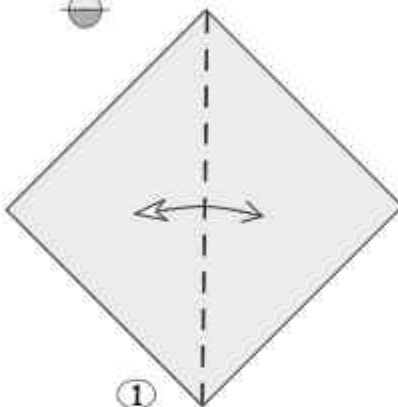

① Precrease the diagonal

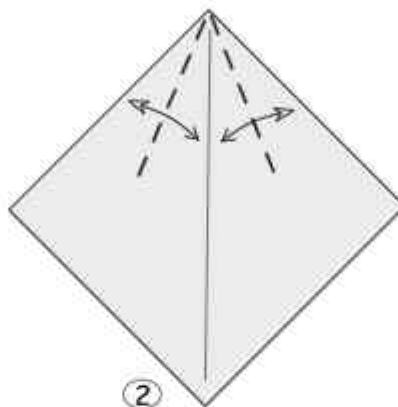

② Precrease 22.5°

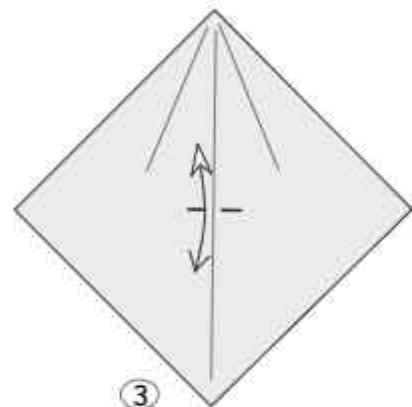

③ Precrease on half

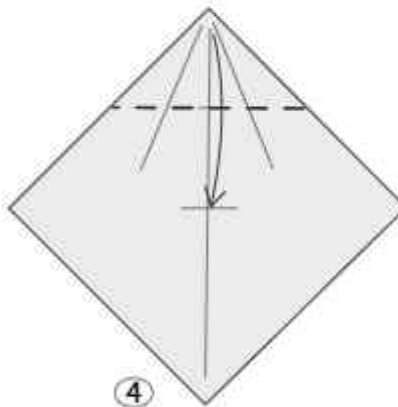

④ Valley fold

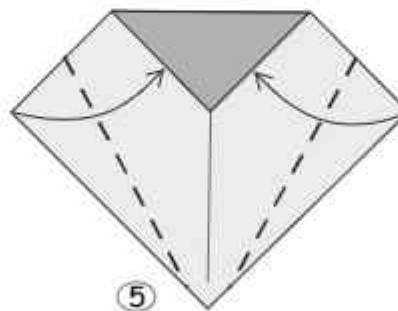

⑤ Valley fold

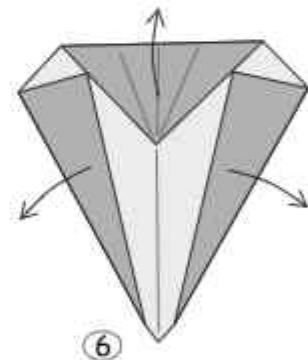

⑥ Unfold

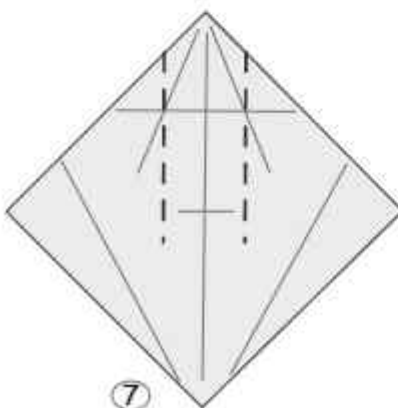

⑦ Precrease

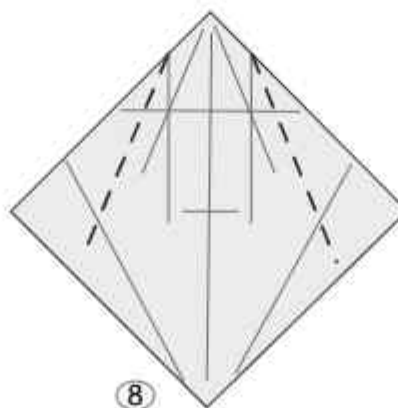

⑧ Precrease 22.5°

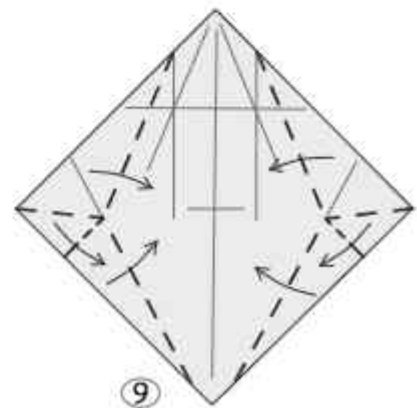

⑨ Fold by the marks

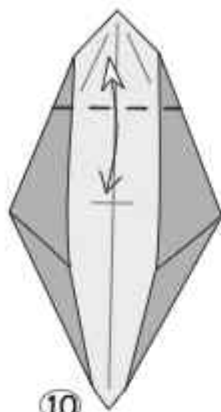

10
Precrease

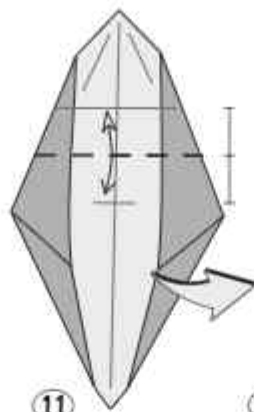

11
Precrease
on half

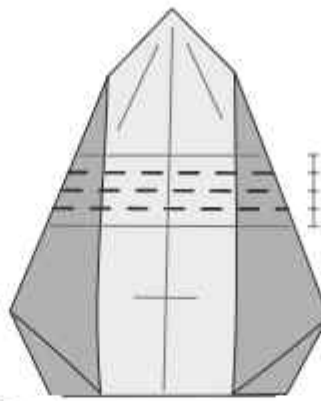

12
Precrease
4 parts

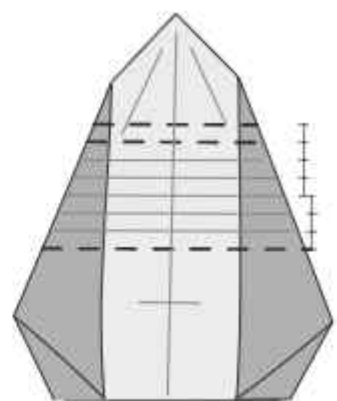

13
Equal parts

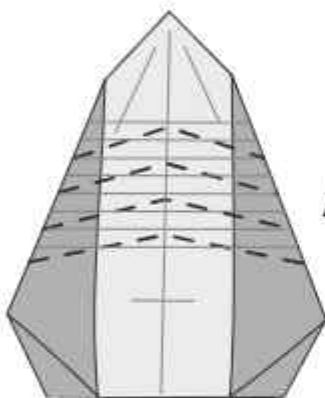

14
Precrease
(Note the point)

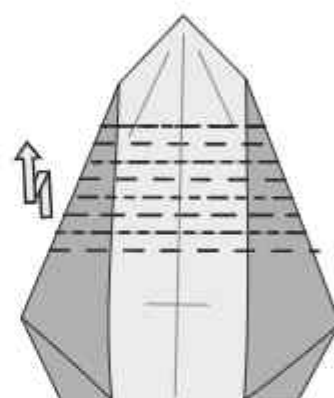

15
Zig zag folds

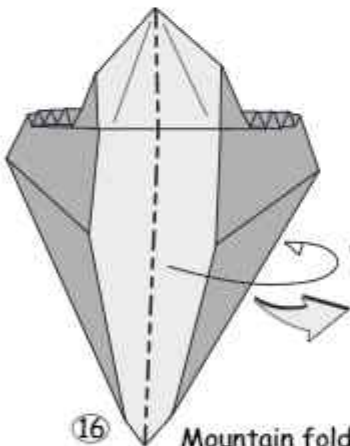

16
Mountain fold

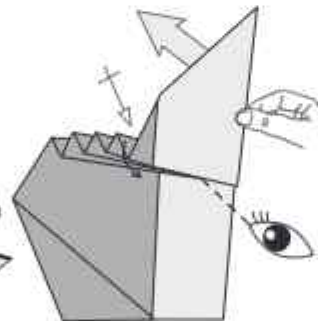

17
Move the layers
(use marks step 14)

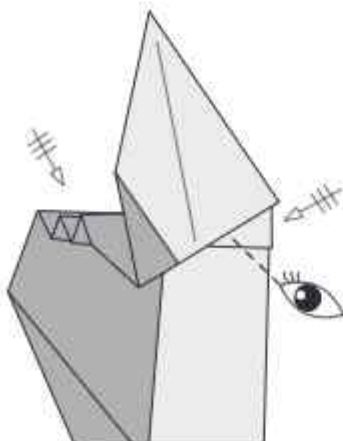

18
Repeat
(use marks step 14)

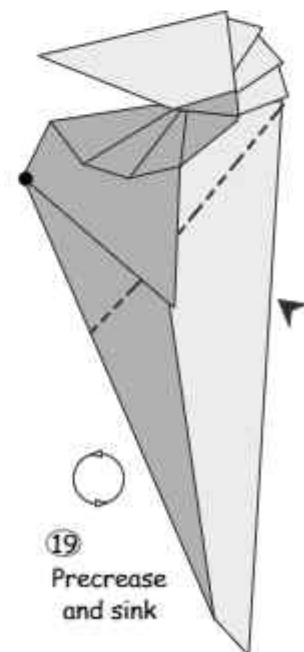

19
Precrease
and sink

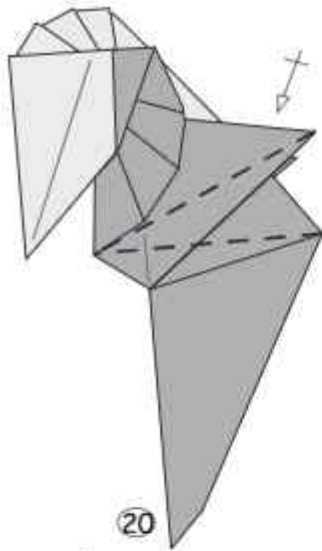

20
Precrease
(only in this layer)

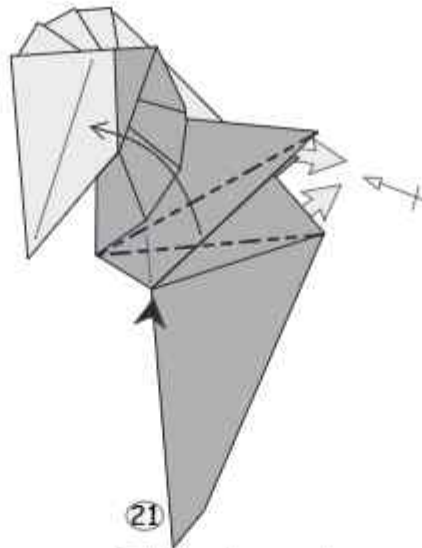

21
Fold by the marks

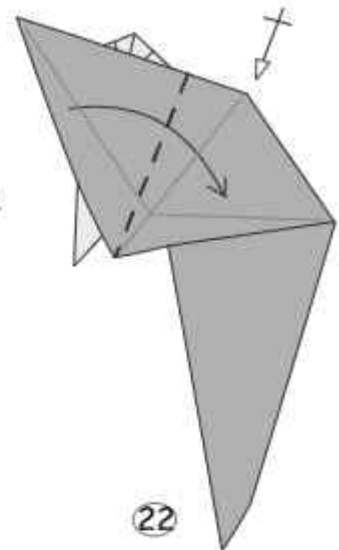

22
Valley fold

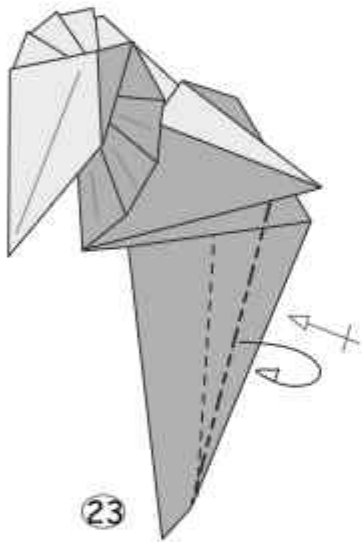

23
Fold behind

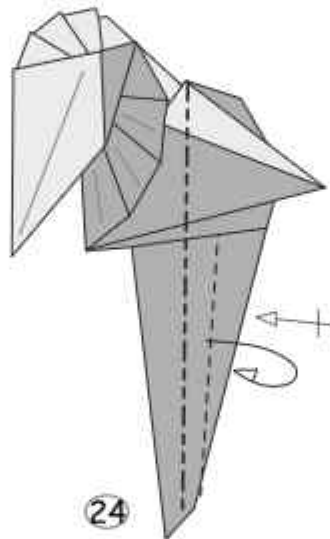

24
Fold behind

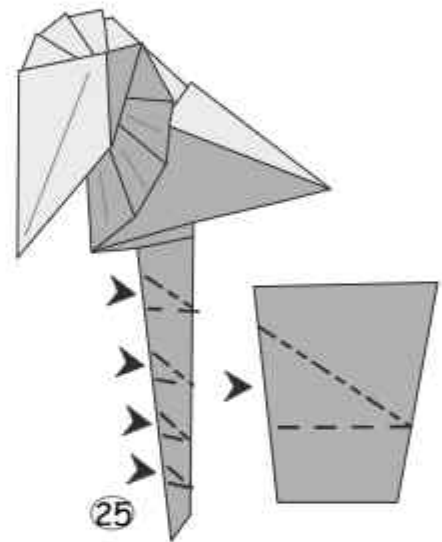

25
Precrease
and fold

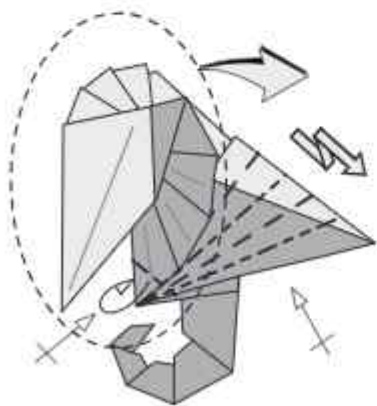

26
Zig zag fold

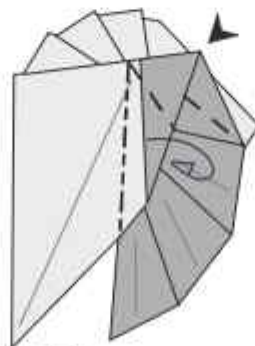

27
Precrease
and fold

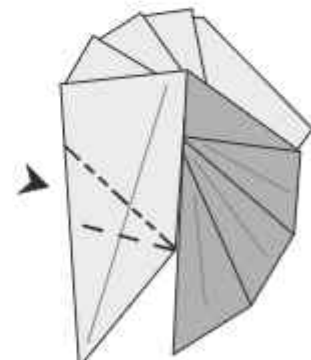

28
Precrease
and sink

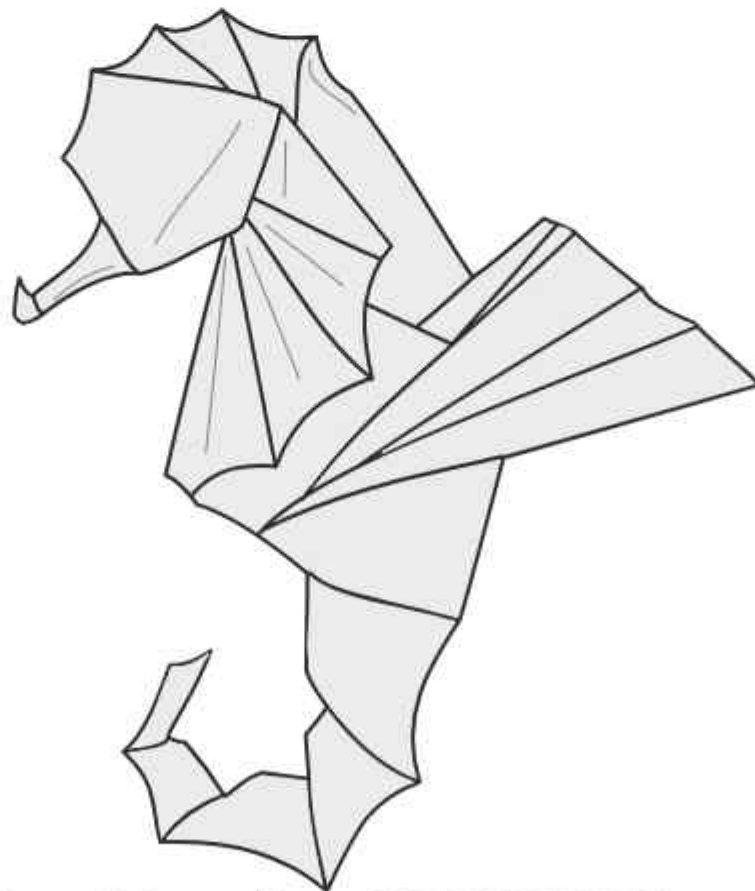
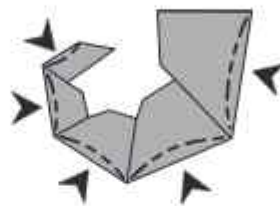
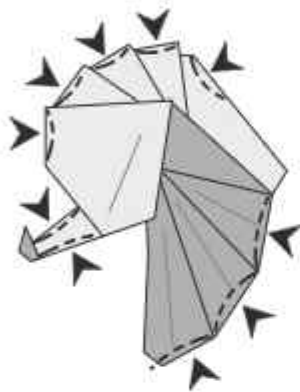
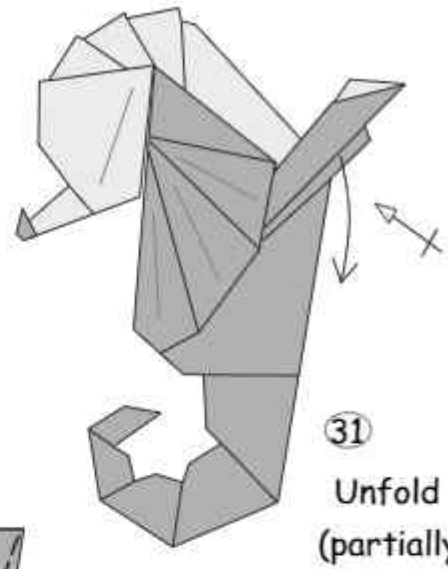
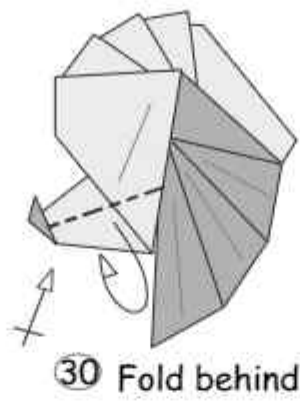
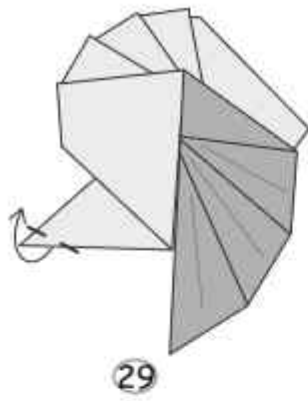

<https://www.flickr.com/photos/143819412@N02/>



**ORIGAMI
ARGENTINA**
Asociación Civil Plegando al Sur

**6^o CONVENCION
DE ORIGAMI
ARGENTINA**

TUCUMÁN 2022

Invitados

Beija / Flaviane koti

CAPÍTULO 1

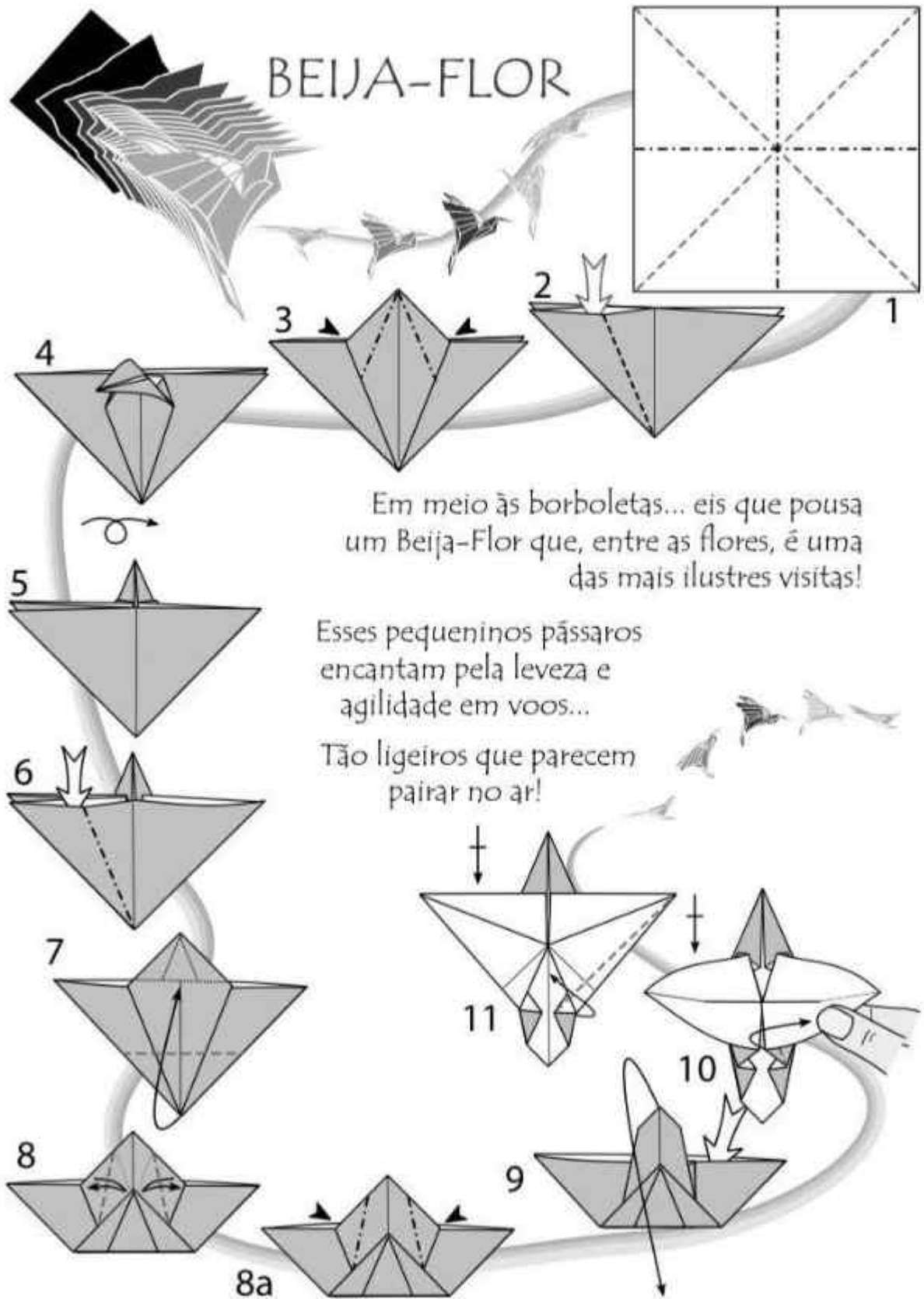

BEIJA-FLORES



Quando um beija-flor voa sobre alguém, é sinal de boas notícias...
...para breve!!!

Pronto!

Papel - 15 x 15 cm
Pronto - 10,5 x 11,5 cm
Grau - Intermediário

Borboleta / Flaviane koti

CAPÍTULO 1

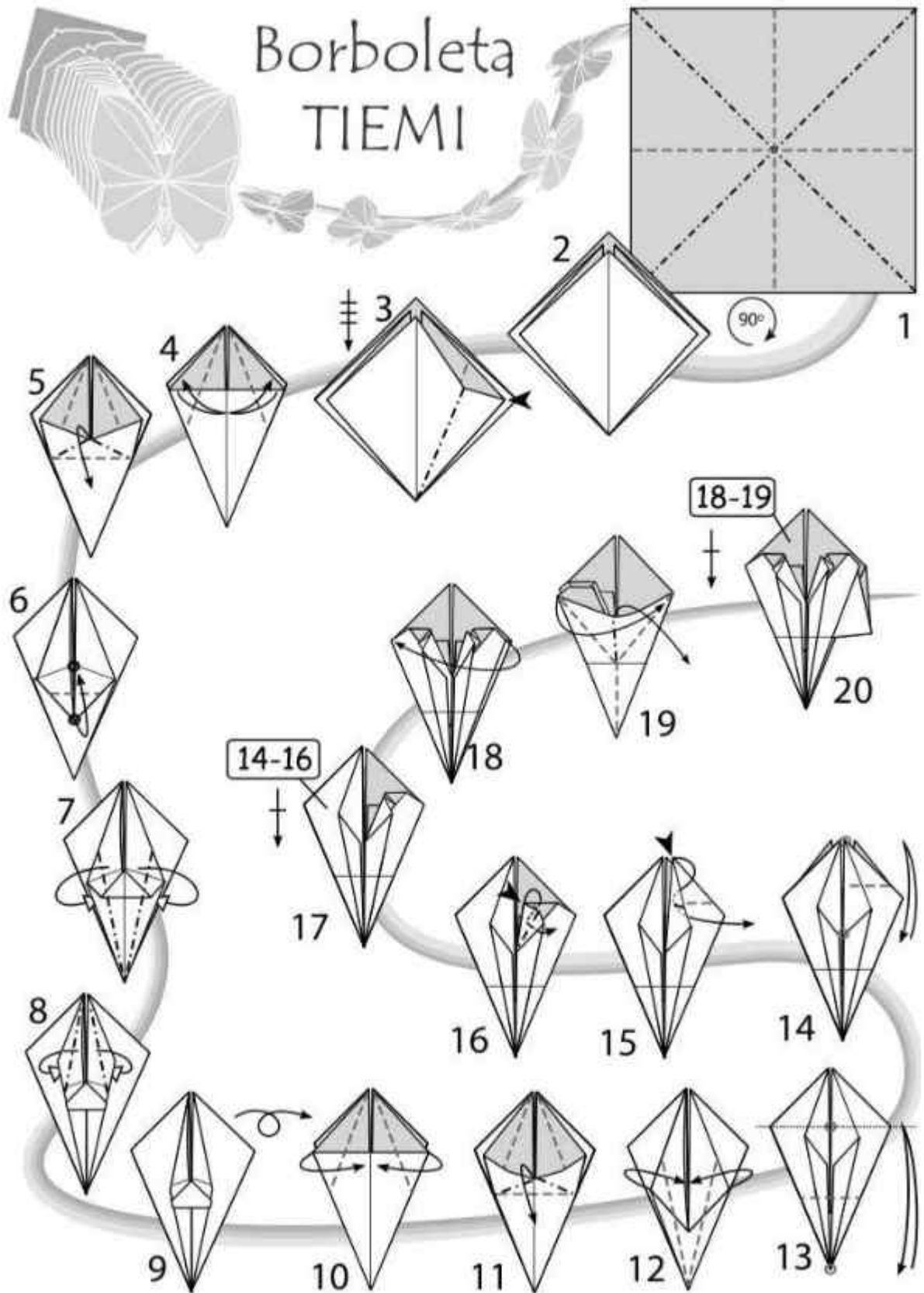

Borboleta TIEMI

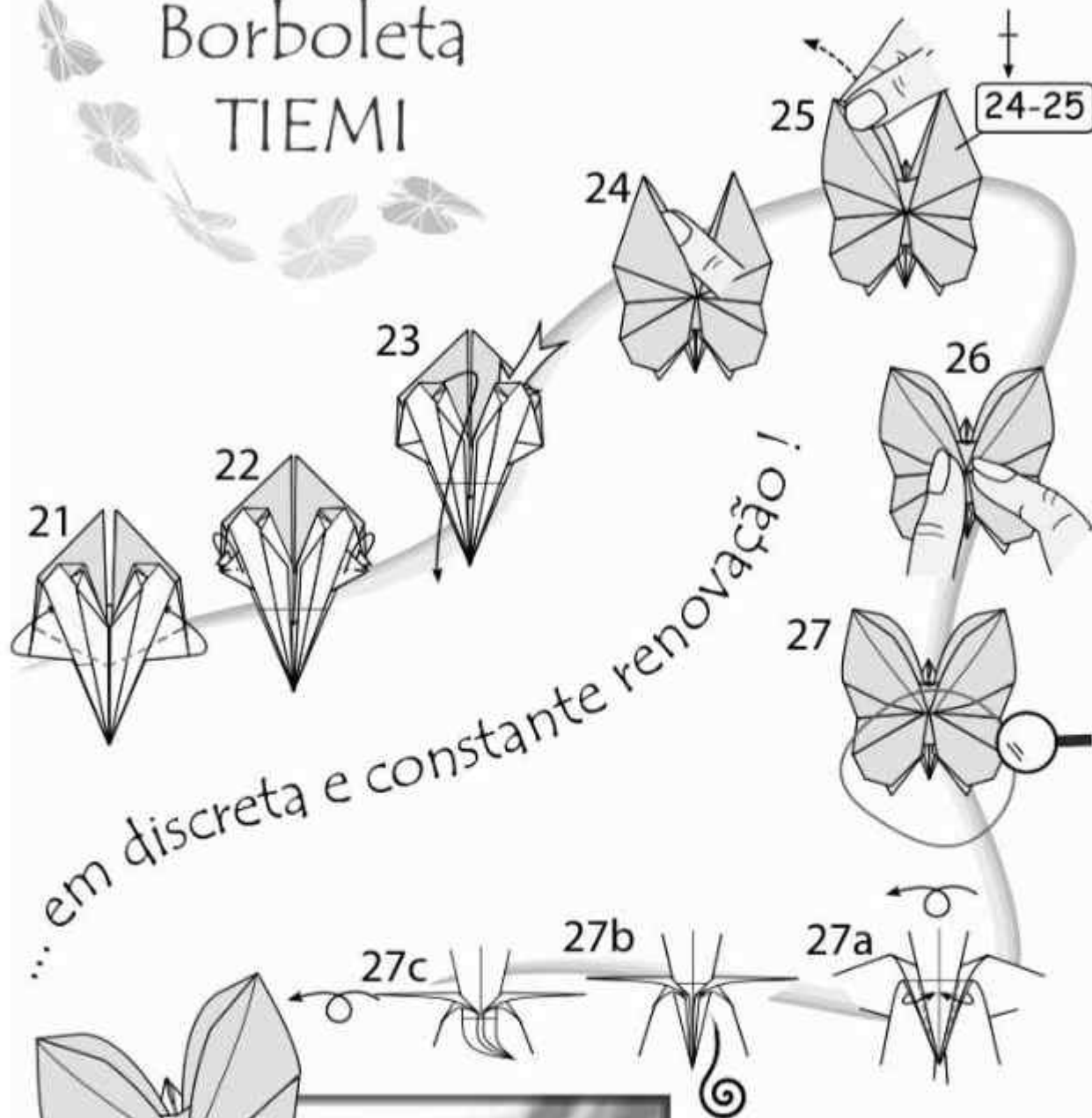

... em discreta e constante renovação!

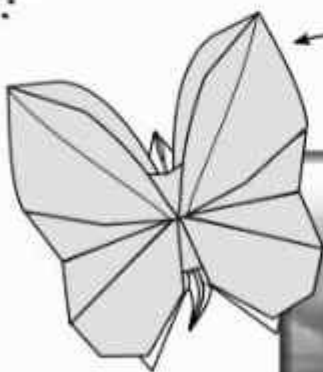

Pronto!

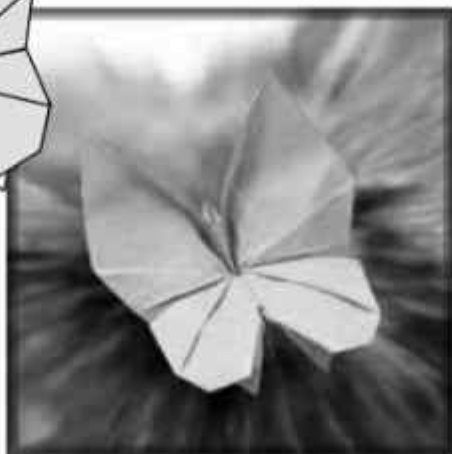

Papel - 15 x 15 cm
Pronto - 9 x 9,5cm
Grau - Intermediário

Rosa del Desierto / Flaviane koti

Diagrama: Vera Young

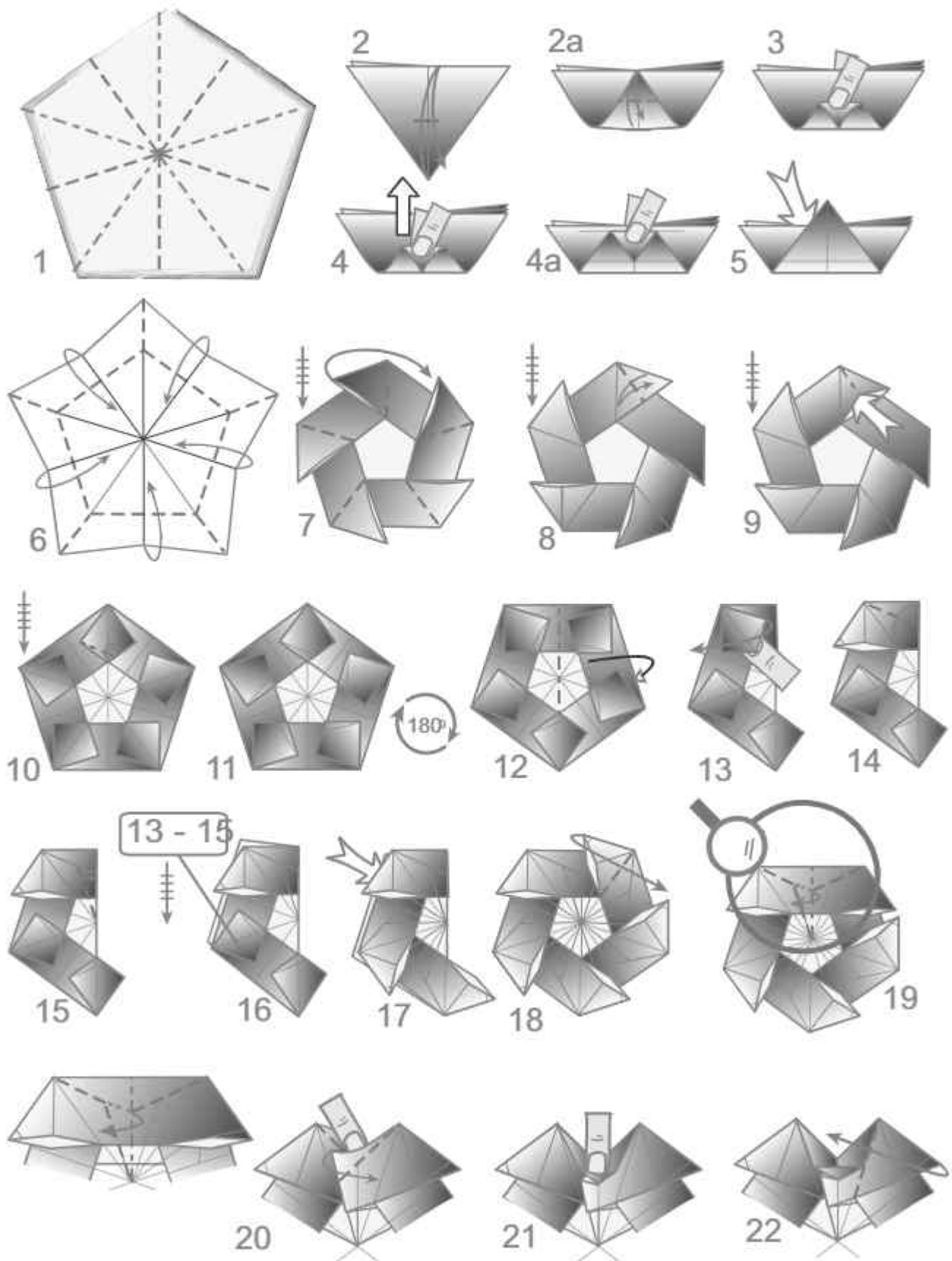

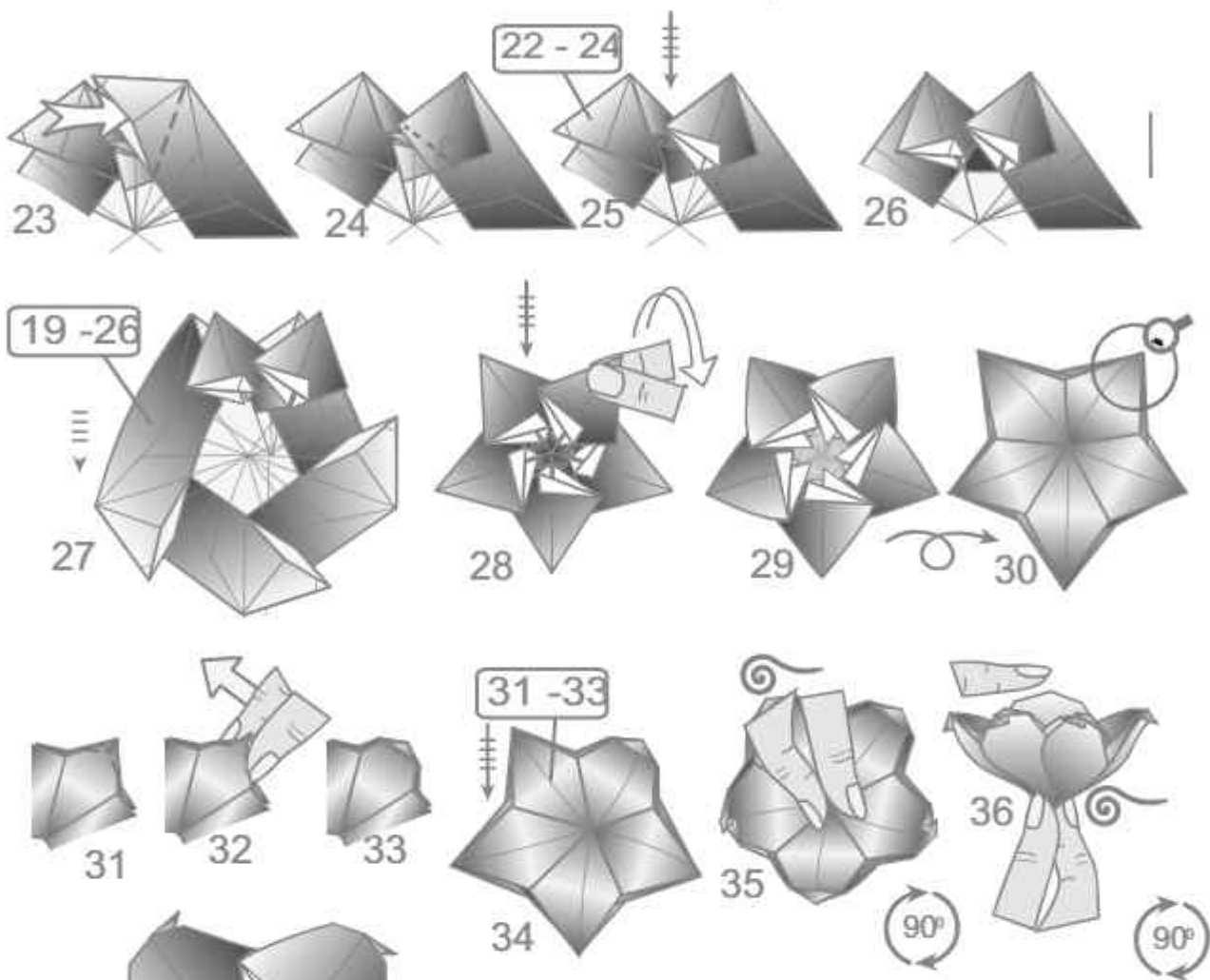

Pronto!



Designer: Flaviane Koti Diagrama: Vera Young

Azaleia / Flaviane koti

Diagrama: Vera Young

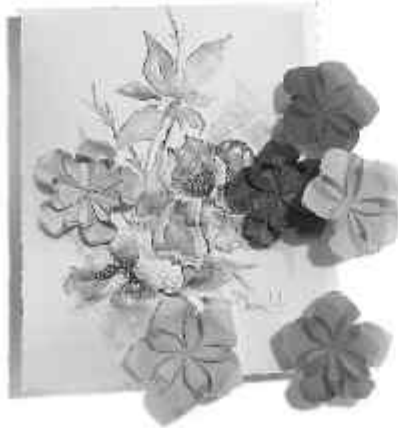
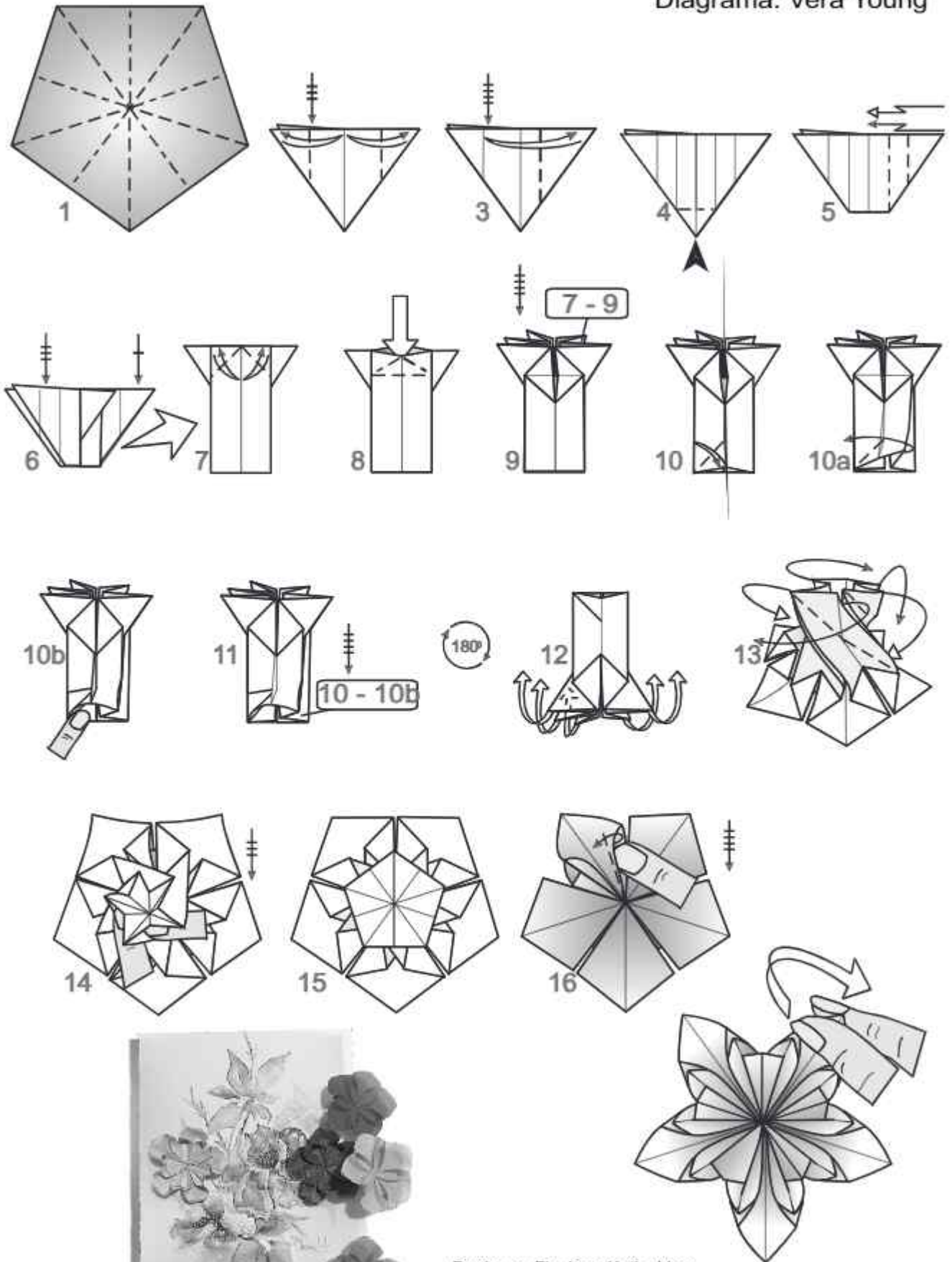

Designer: Flaviane Koti e Vera Young
Diagrama: Vera Young

Kusudama Vórtex / Flaviane koti

Kusudama Vórtex

Designer: Flaviane Koti @flavianekoti

Diagrama: Iana Bezerra @dobra_a_dobra

Julho/2022

30 Módulos sem cola

Papel 1:2

Papel de 3,75cm x 7,5cm

Tamanho final: 7,5 diâmetro

Papel de 5cm x 10cm

Tamanho final: 10,5 cm diâmetro

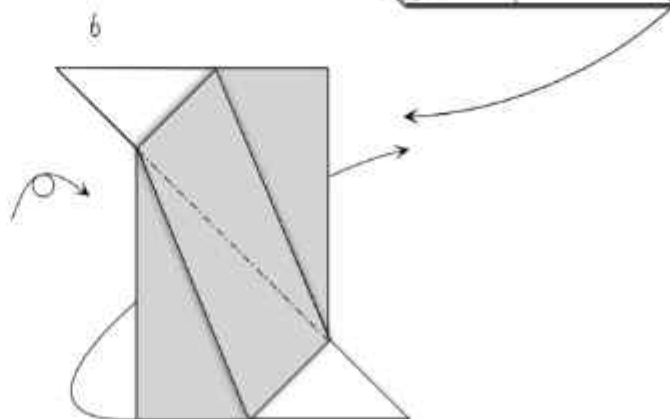
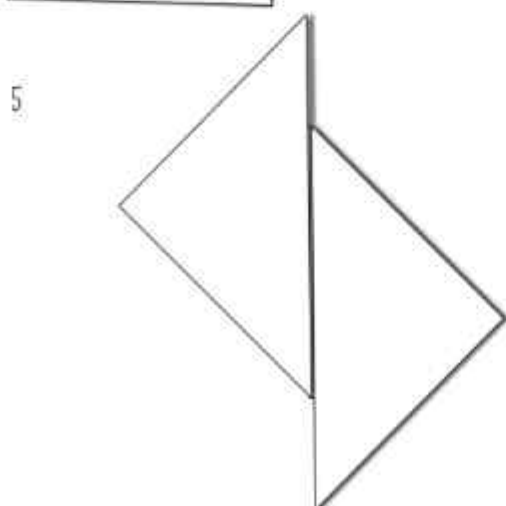
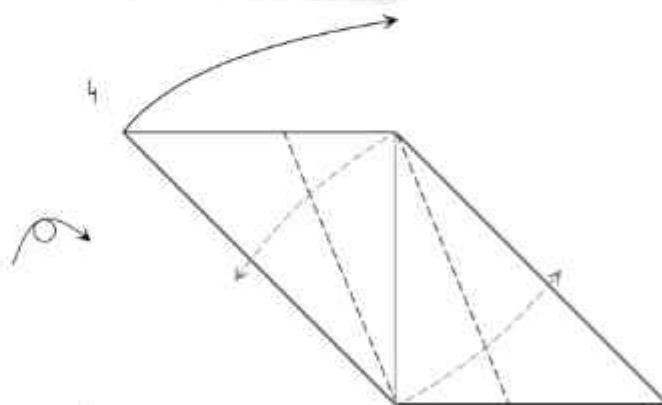
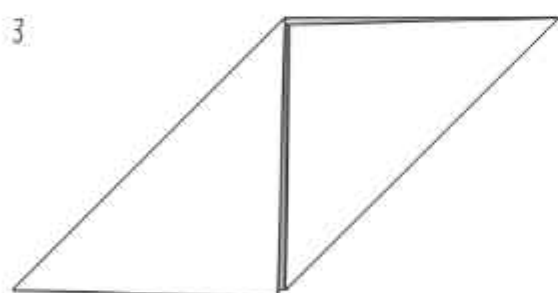
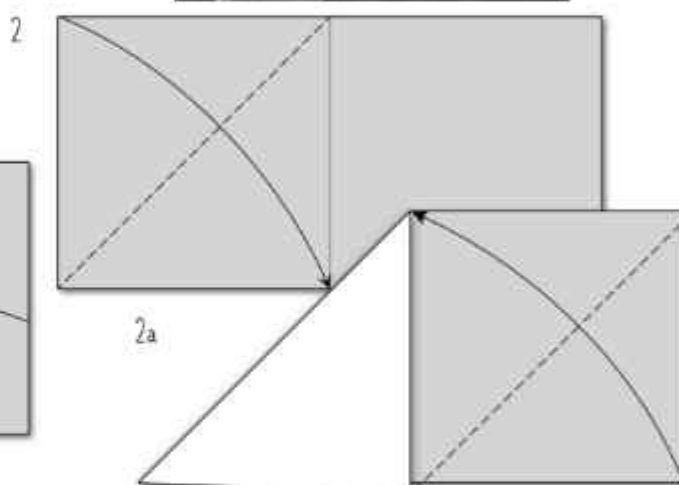
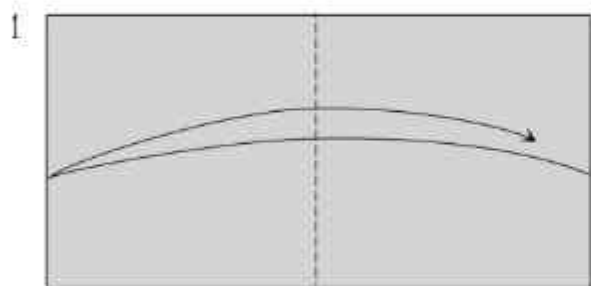

Kusudama Vortex

Designer:
Flaviane Koti @flavianekoti
Diagrama: Iana Bezerra
@dobra_a_dobra

Julho/2022

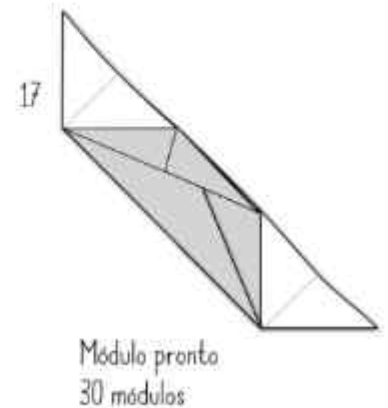
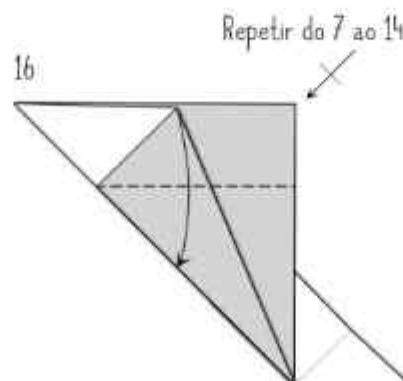
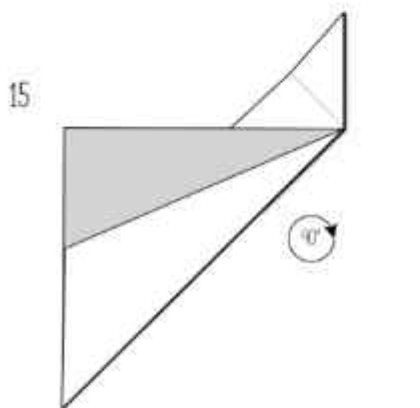
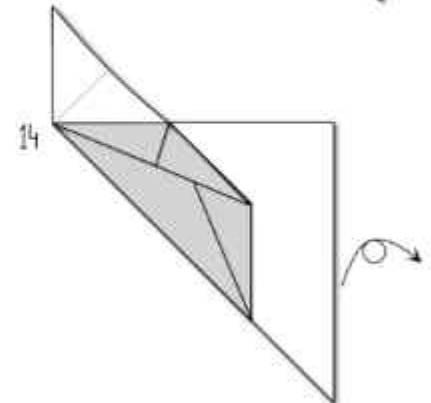
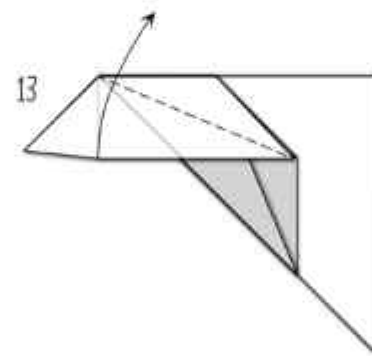
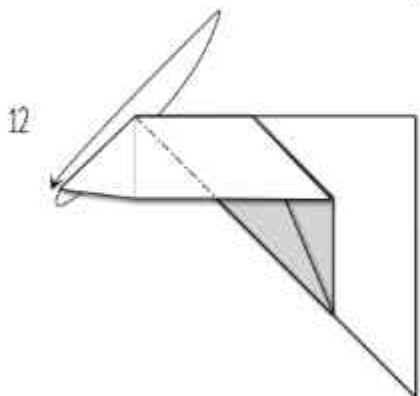
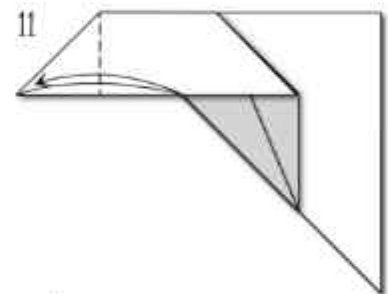
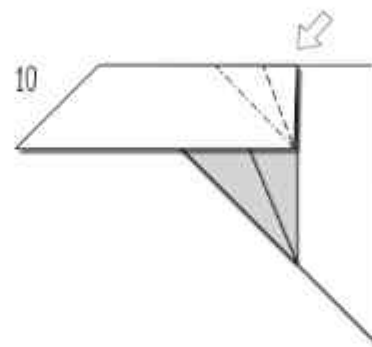
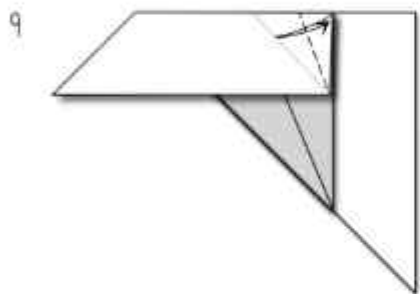
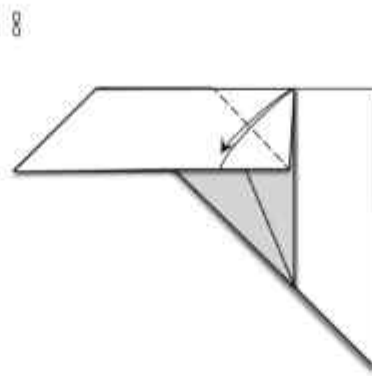
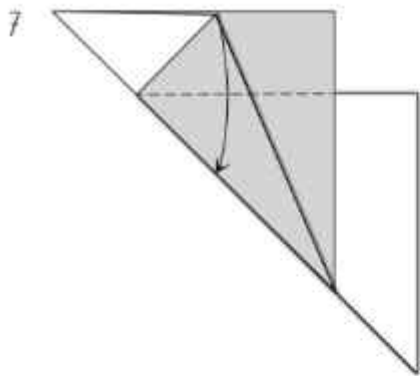

Módulo pronto
30 módulos

Kusudama Vortex

Designer:
Flaviane Koti @flavianekoti
Diagrama: Iana Bezerra
@dobra_a_dobra

Julho/2022

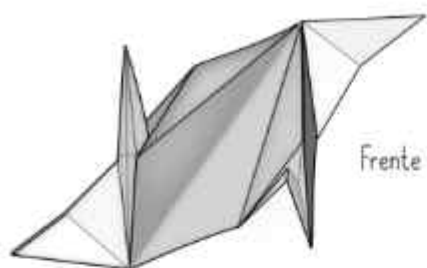

Frente

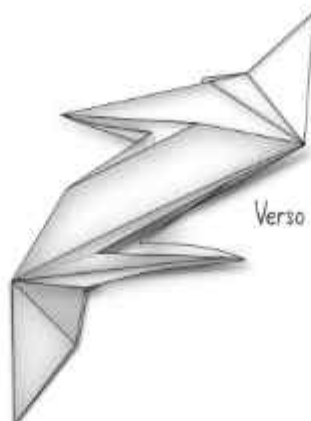

Verso

Montagem



Visão interna

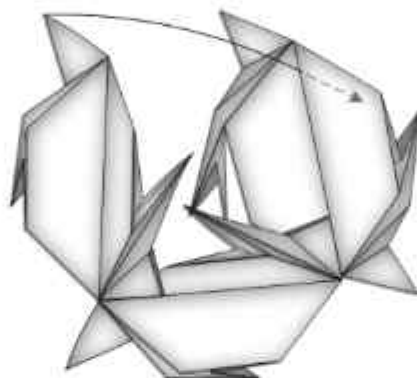

Visão interna

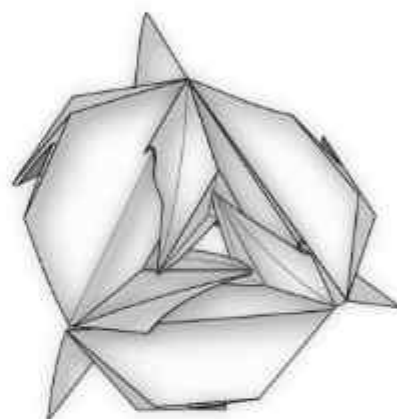

Módulo Vortex

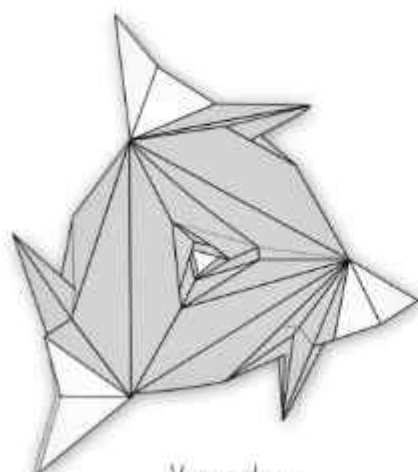

Visão externa

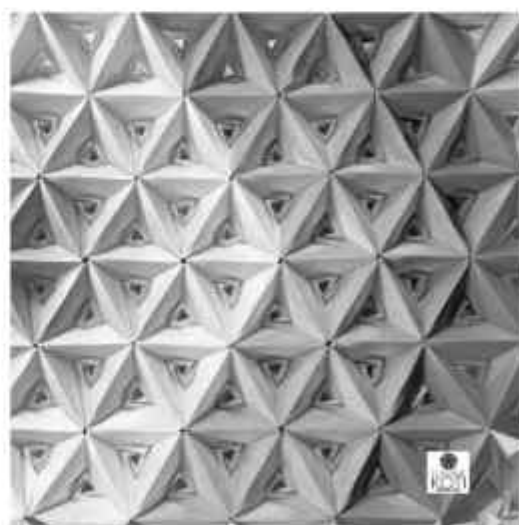

Baby Gorilla / Fernando Chura

Design and diagram by:
Fernando Chura Huanca.

Recommended size: 40 cm.

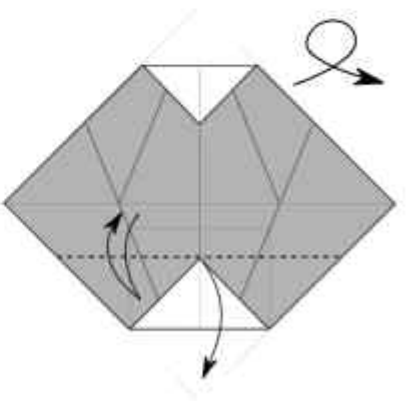
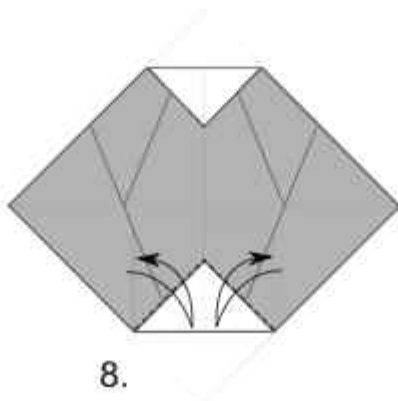
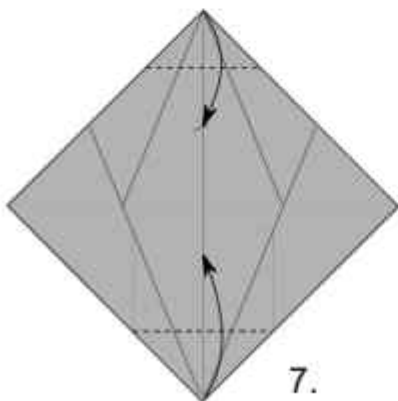
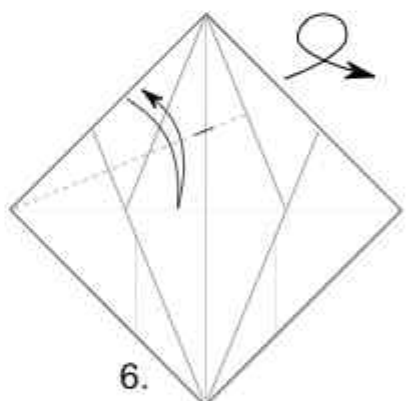
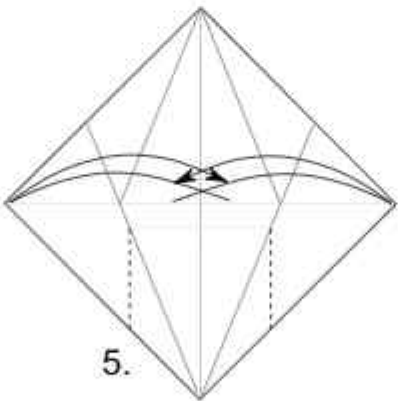
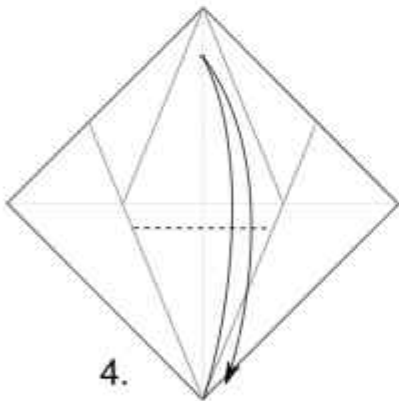
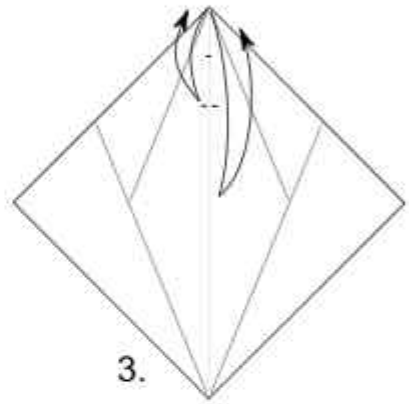
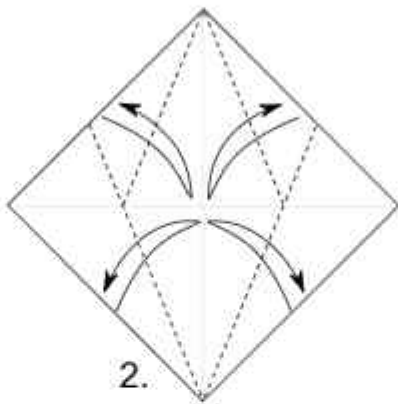
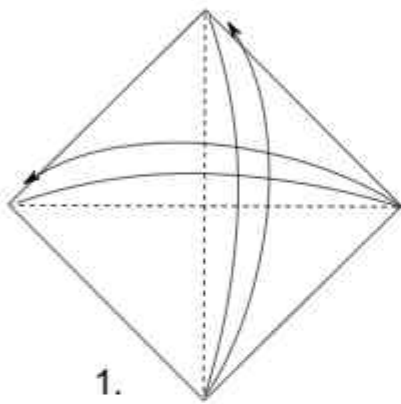
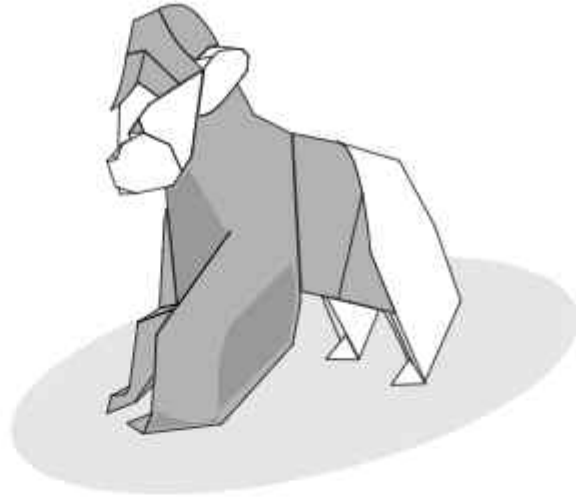

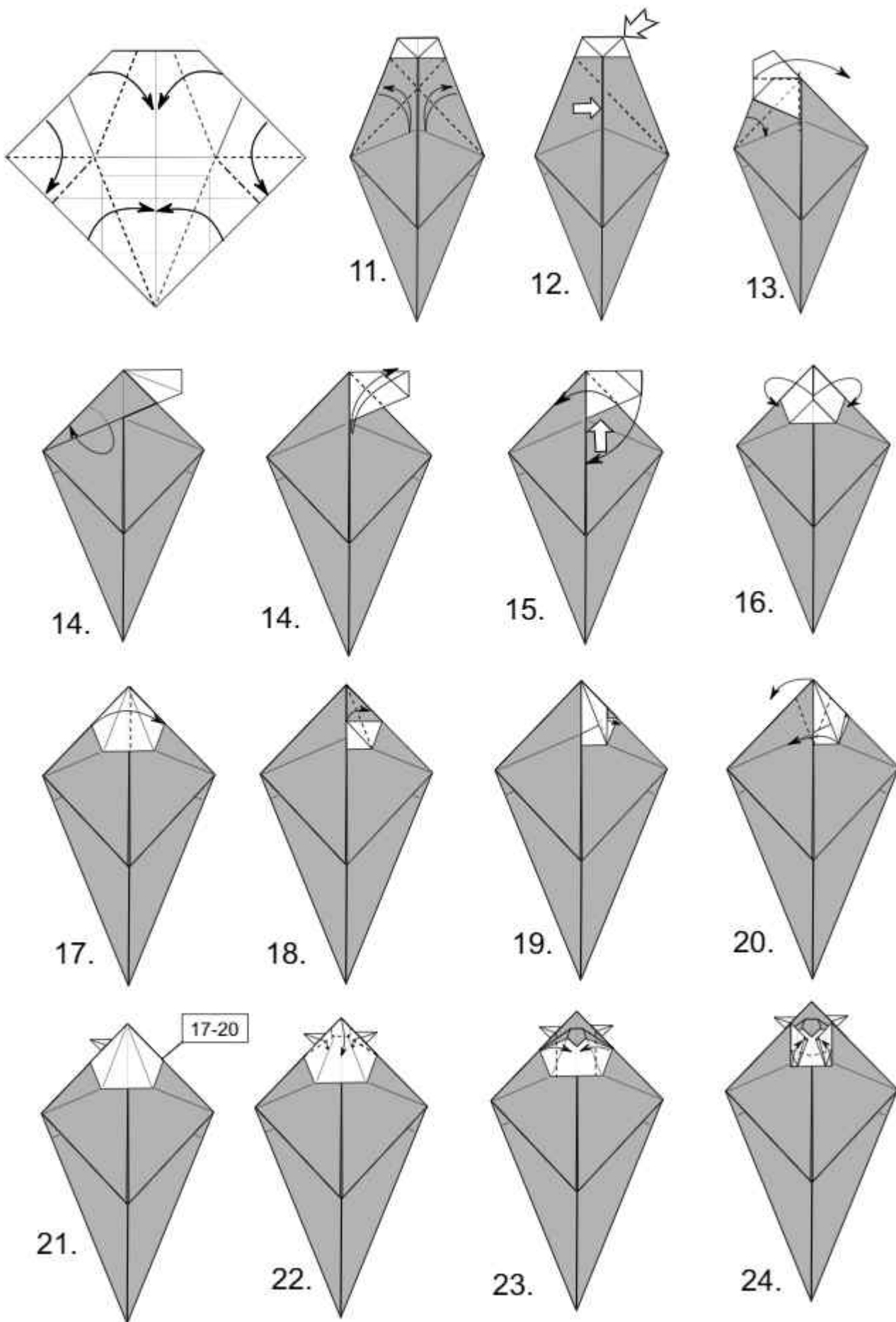

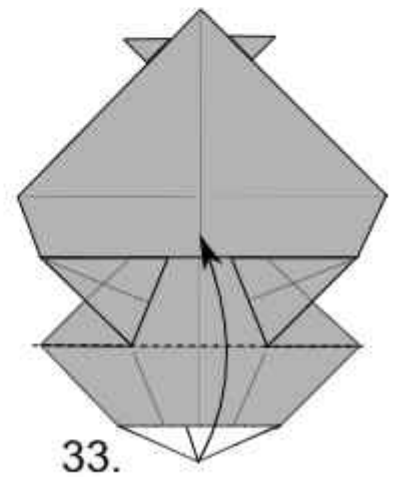
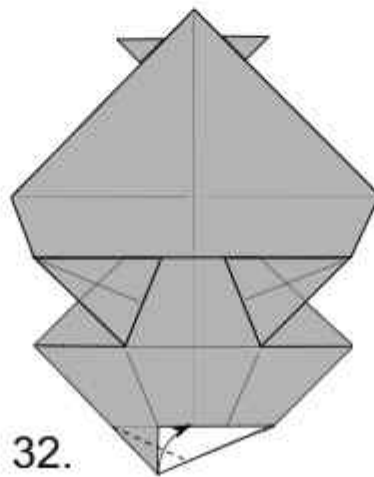
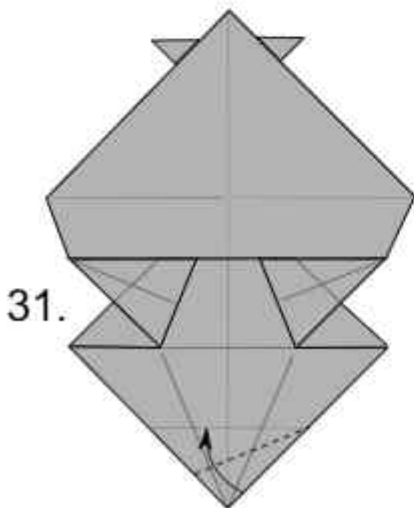
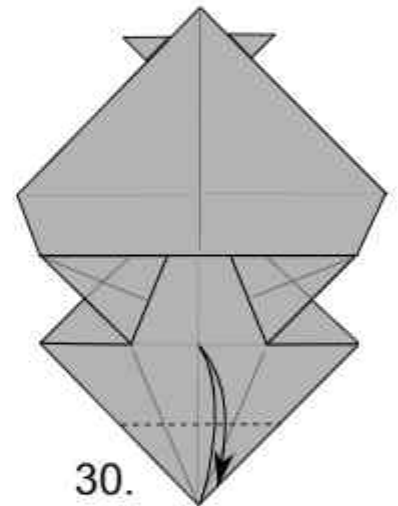
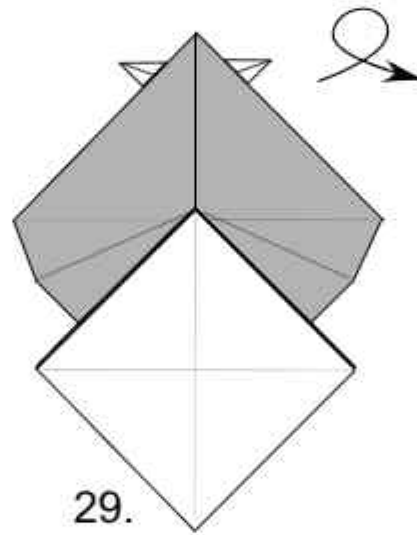
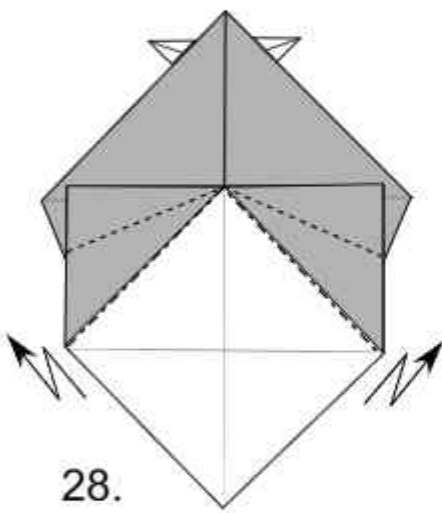
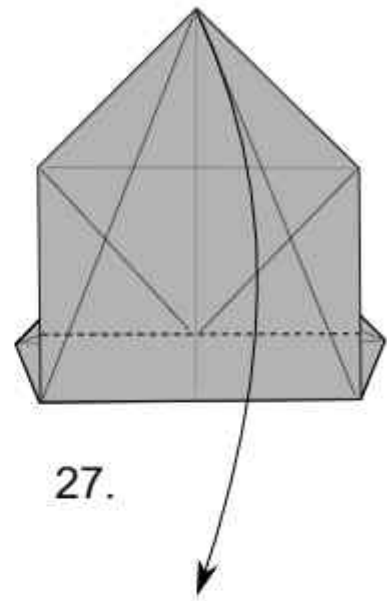
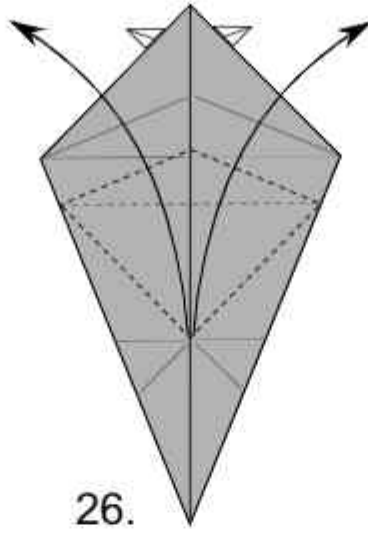
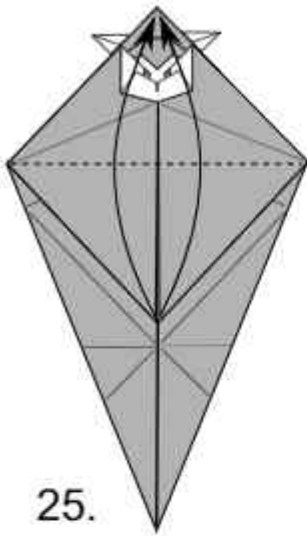

34.

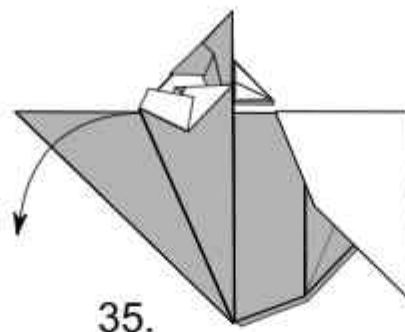
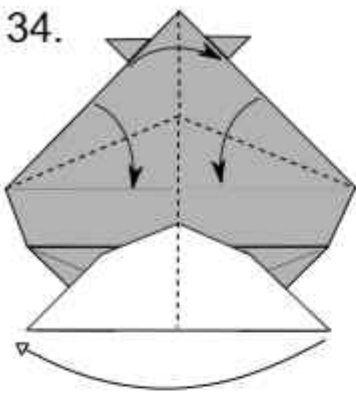

35.

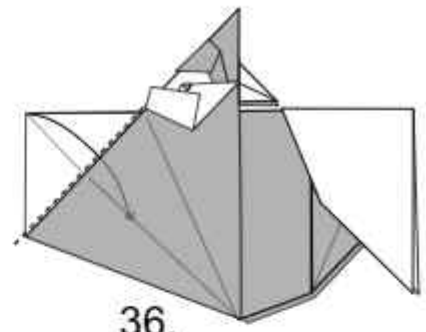

36.

35-36

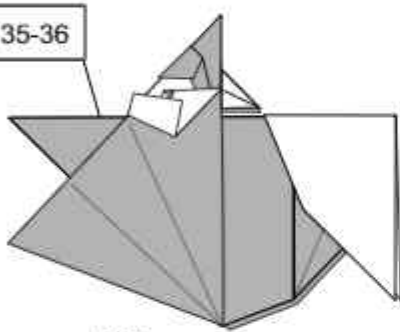

37.

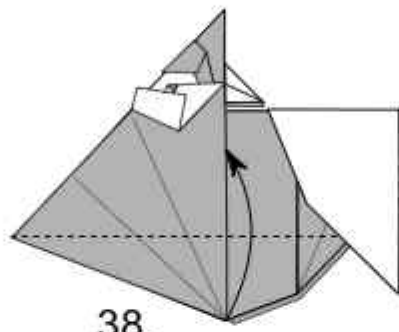

38.

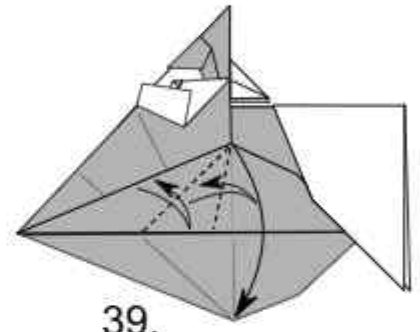

39.

38-40

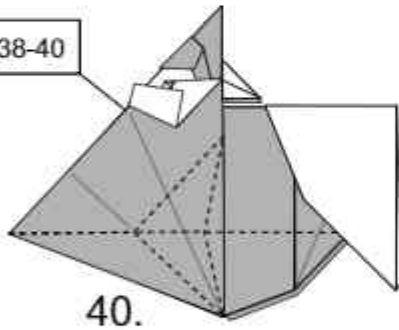

40.

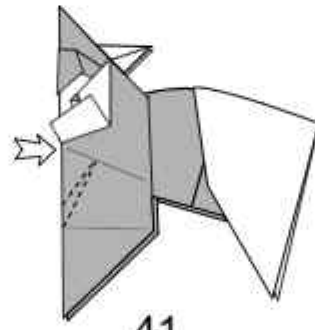

41.

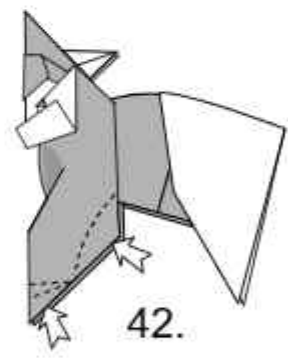

42.

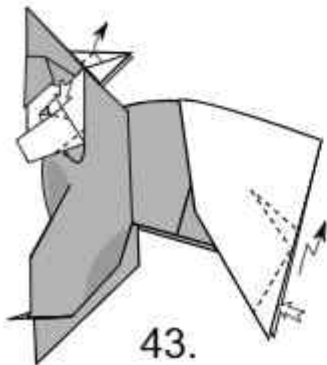

43.

42-43

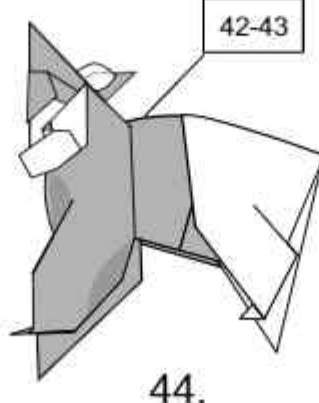

44.

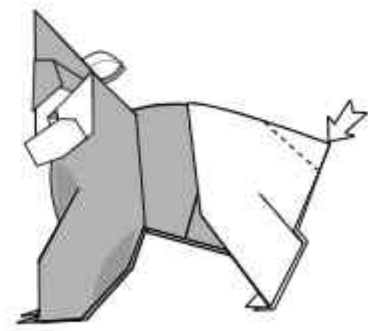

45.

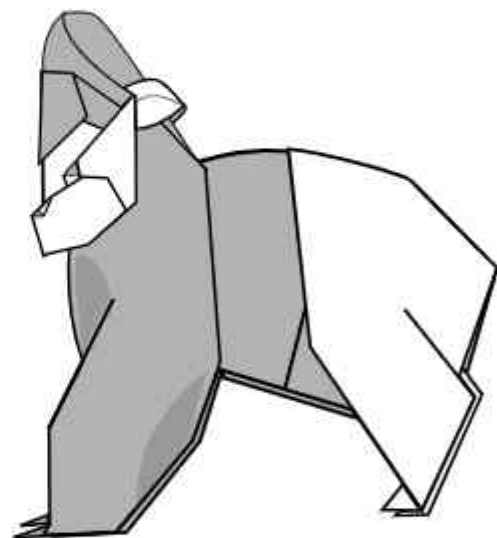
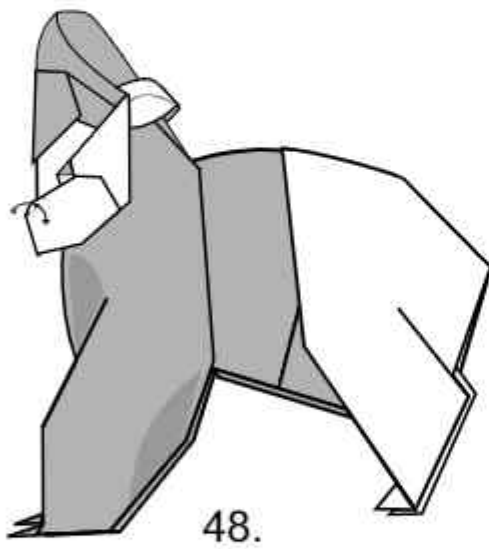
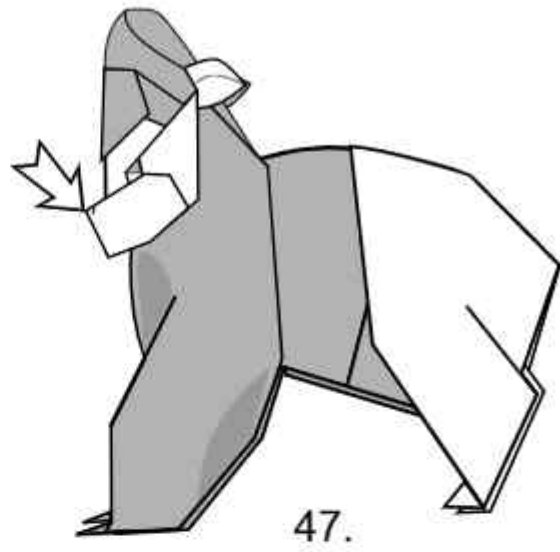
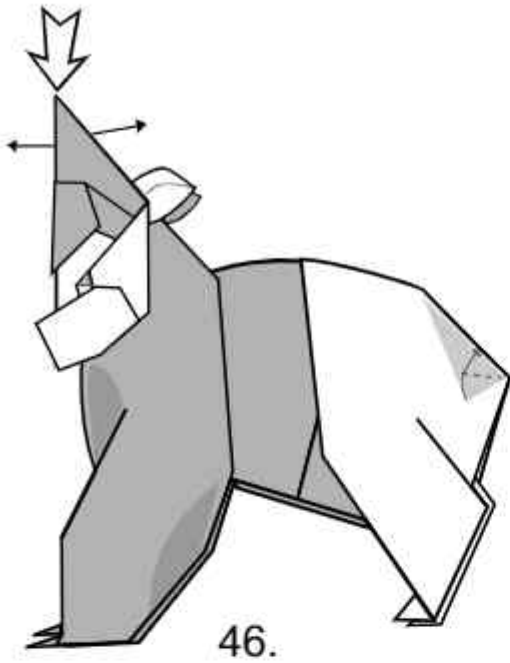

Finished model!

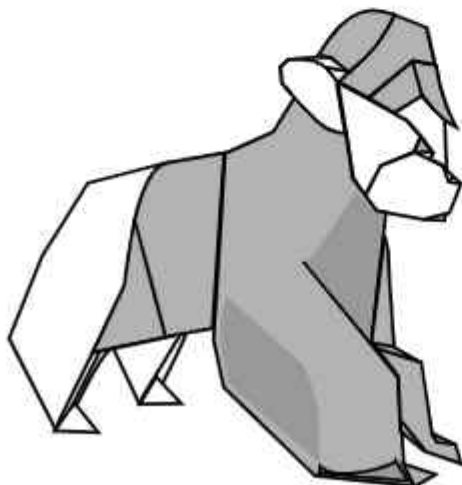

Conejo

Diseño: Fernando Chura H.

Pais: Bolivia.

Fecha de creacion: 260-03- 19

Tamaño de papel: 25cm.

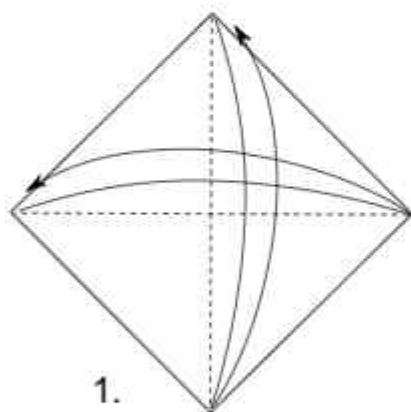
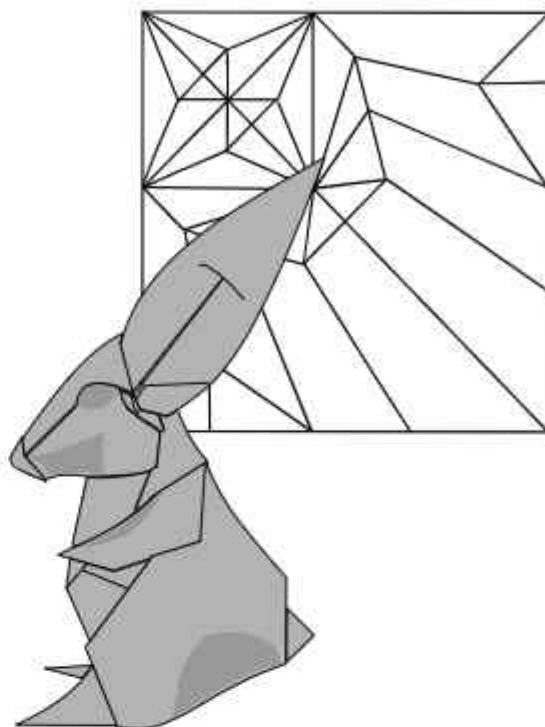

1.

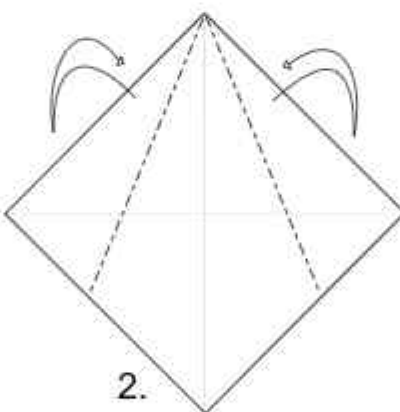

2.

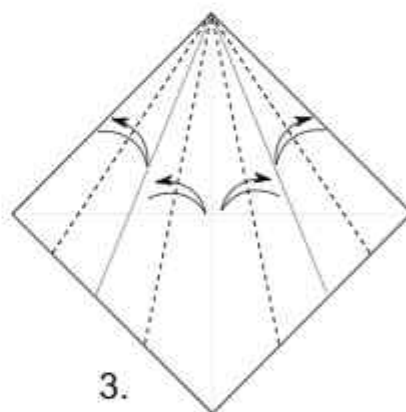

3.

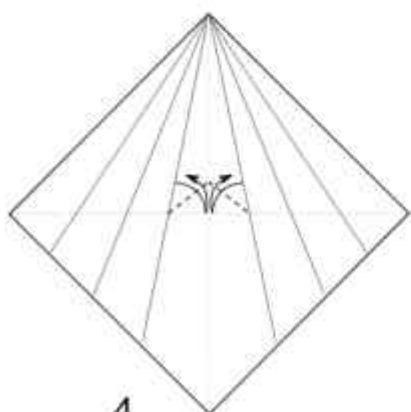

4.

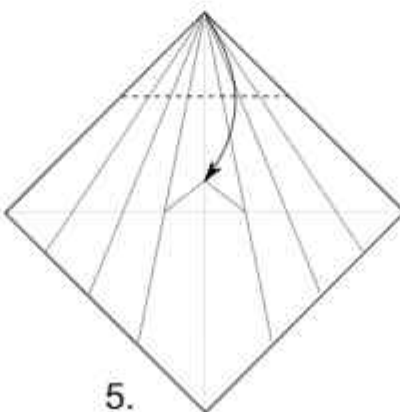

5.

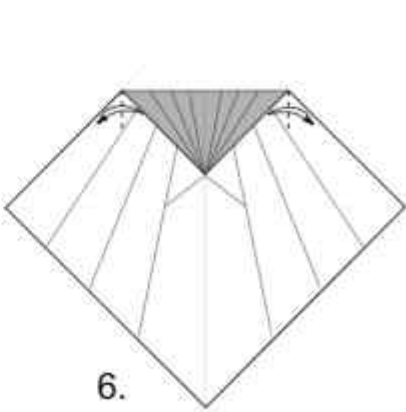

6.

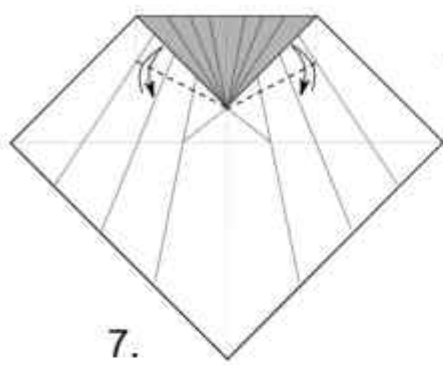

7.

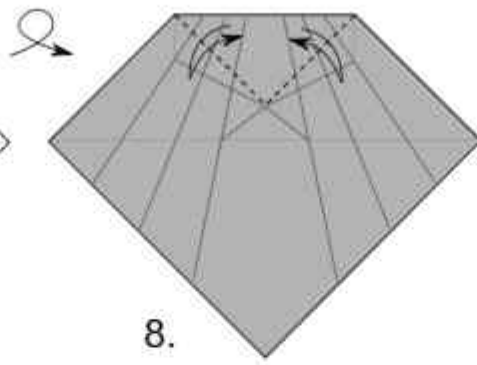

8.

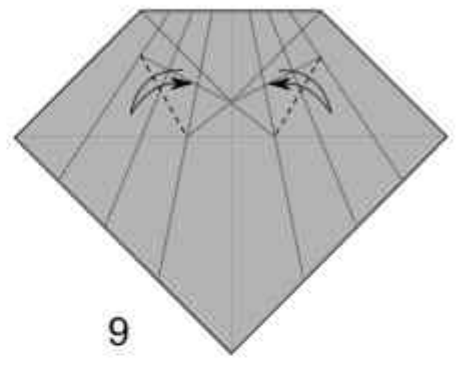

9.

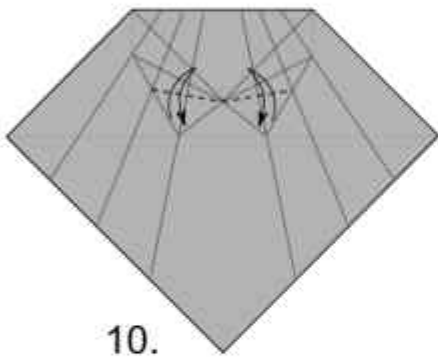

10.

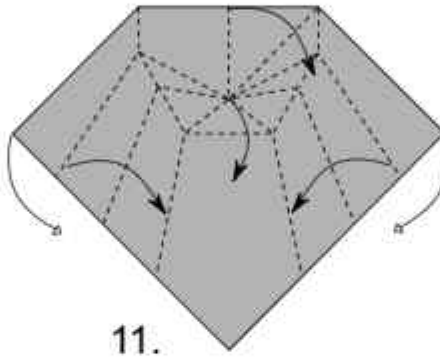

11.

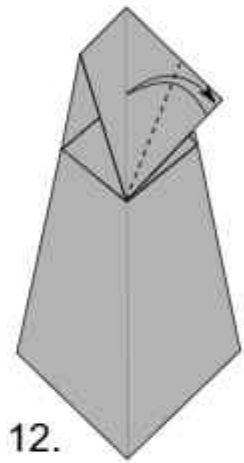

12.

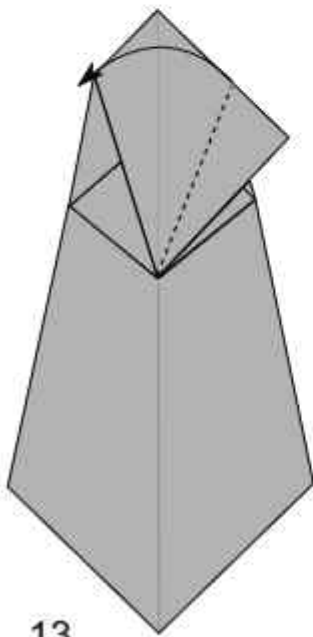

13.

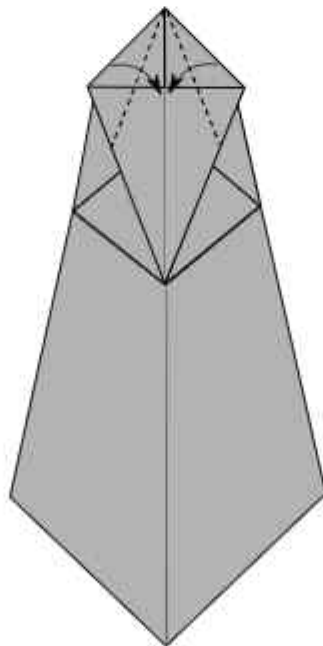

14.

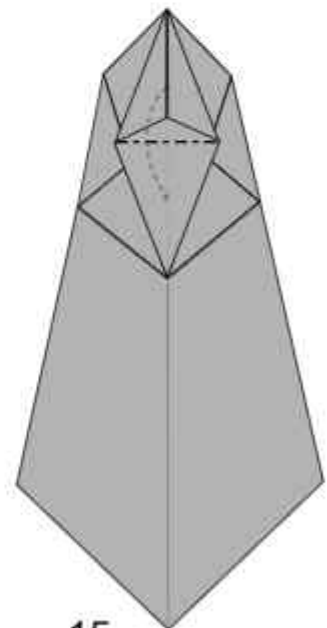

15.

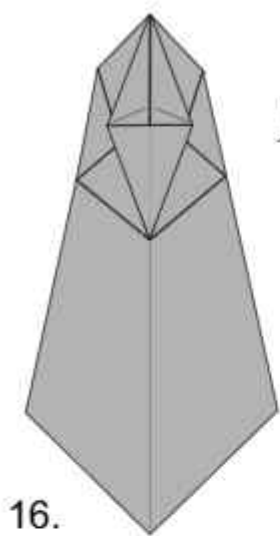

16.

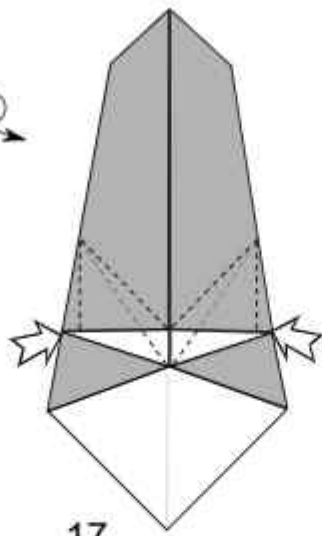

17.

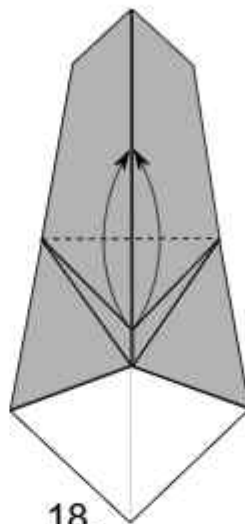

18.

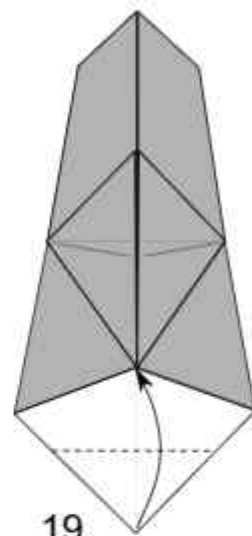

19.

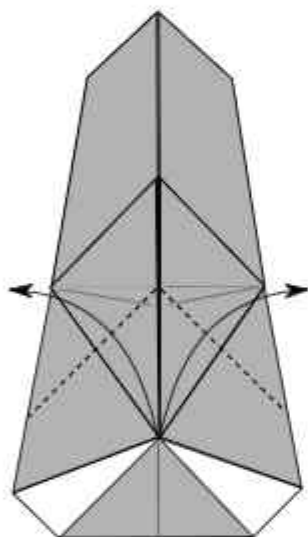

20.

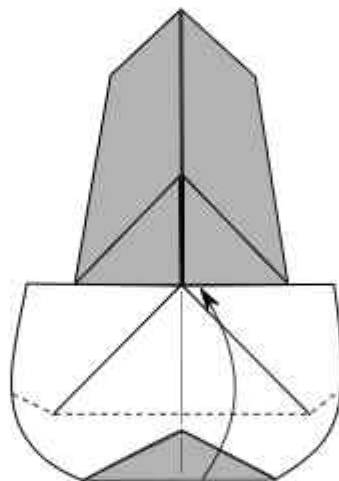

21.

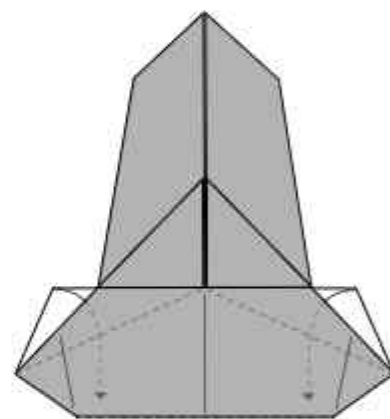

22.

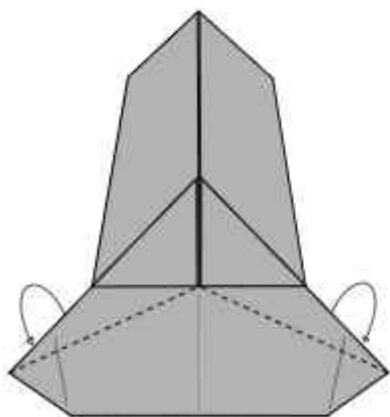

23.

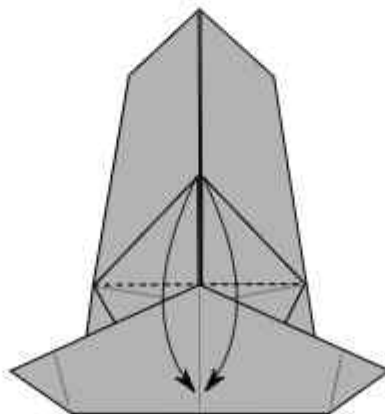

24

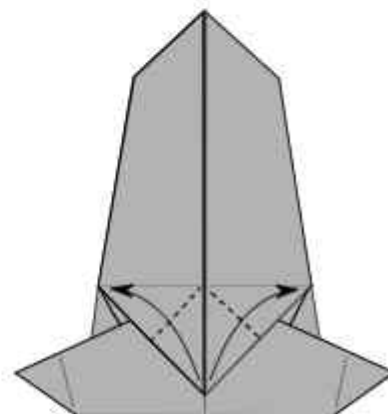

25.

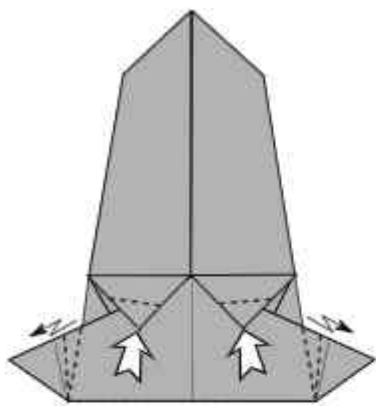

26.

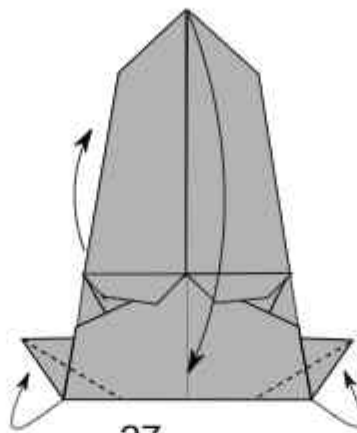

27.

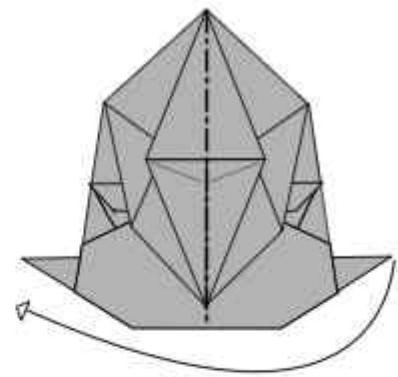

28.

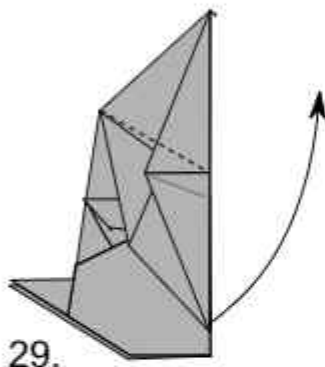

29.

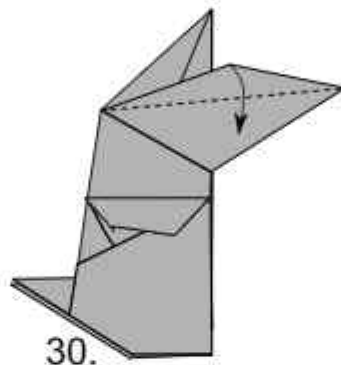

30.

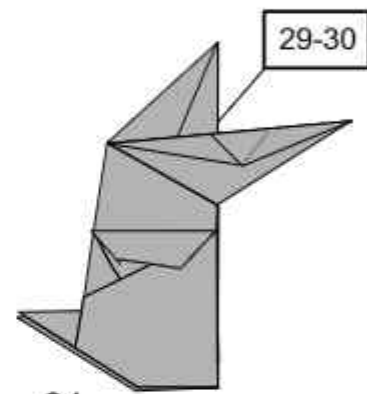

31.

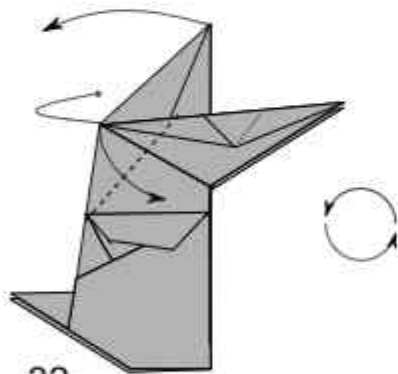

32.

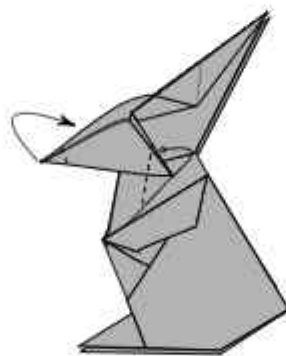

33.



34.

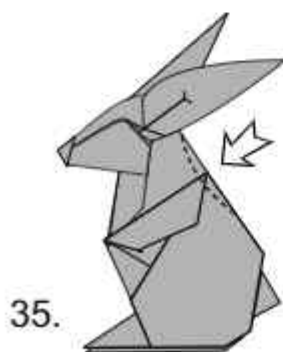

35.

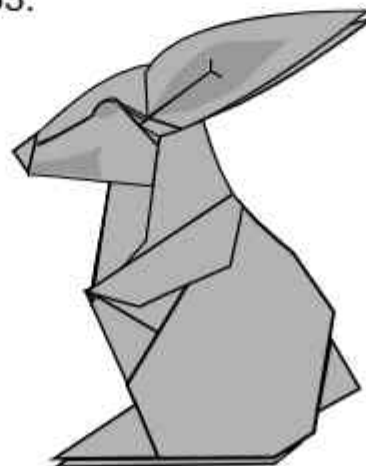

Gacela de Clark / Fernando chura

Gacela de Clark

(Ammodorcas clarkei)

Diseño: Fernando Chura H.

Papel recomendado: Craft - Doble seda.

Tamaño recomendado: 55bcm.

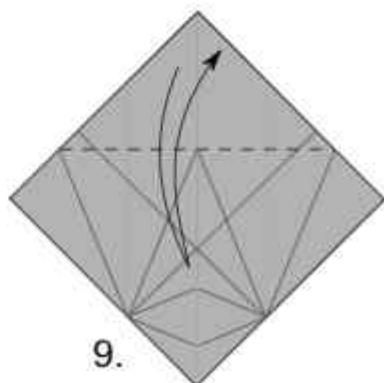
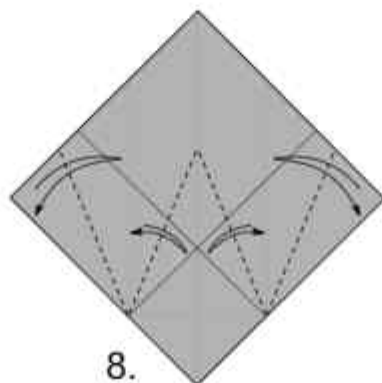
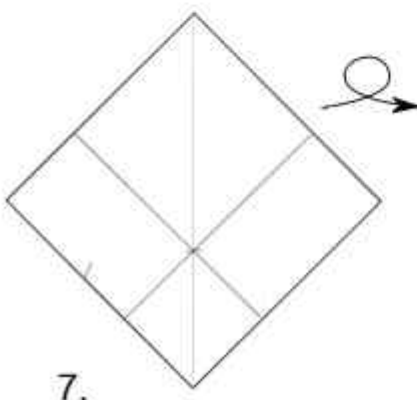
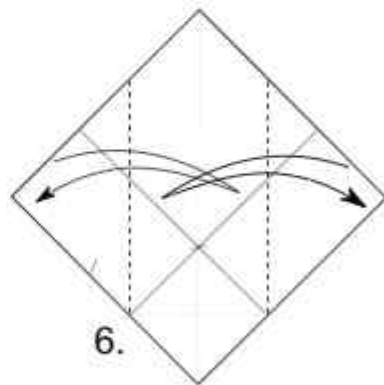
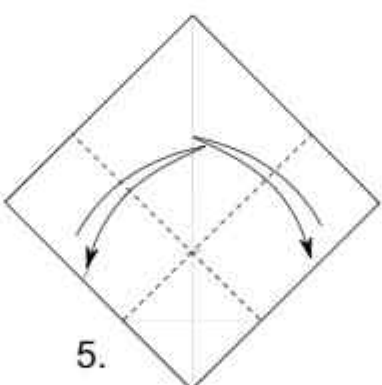
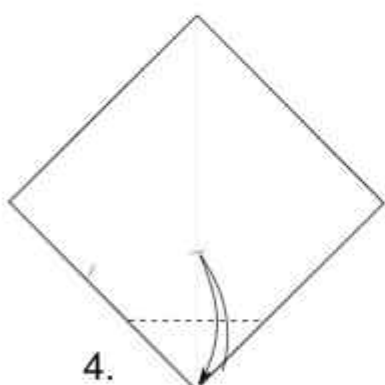
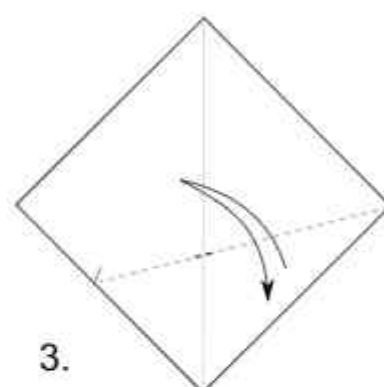
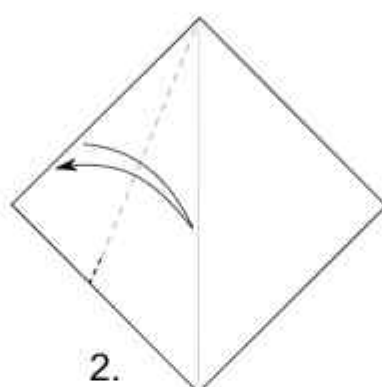
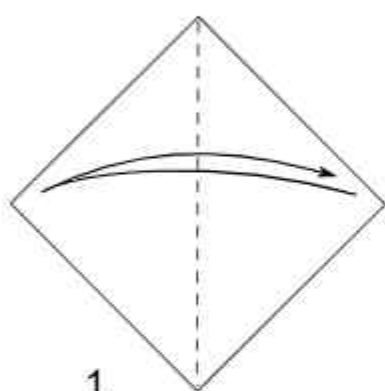
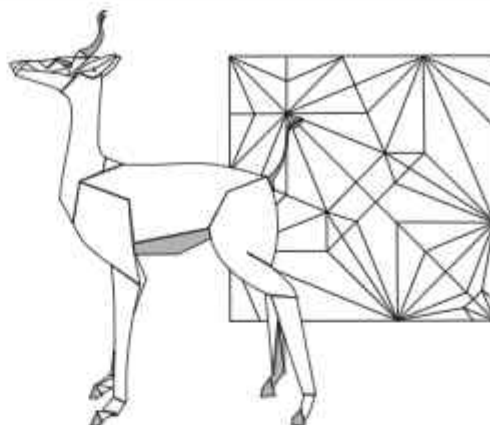

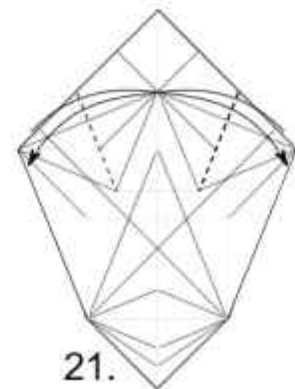
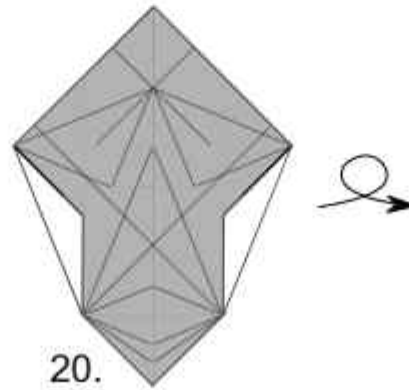
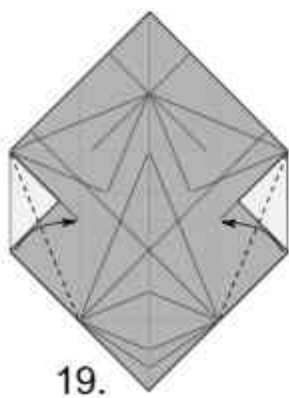
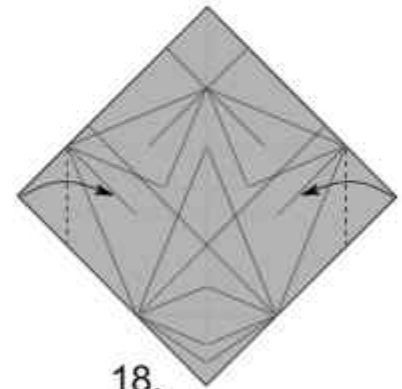
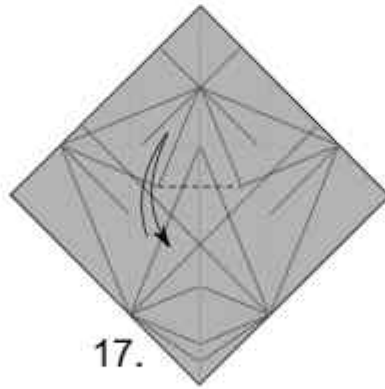
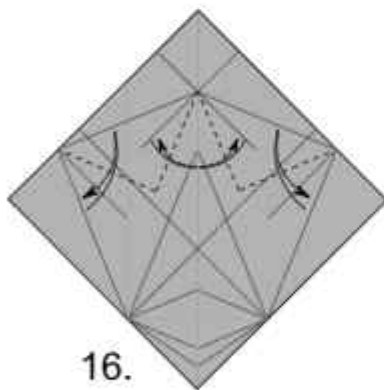
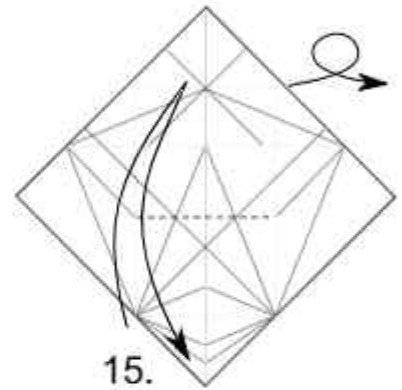
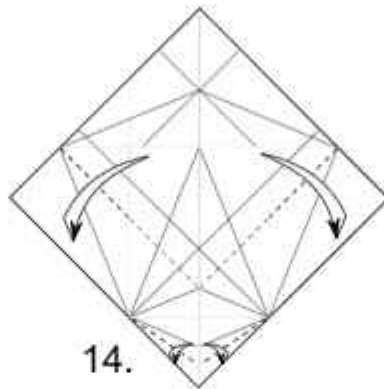
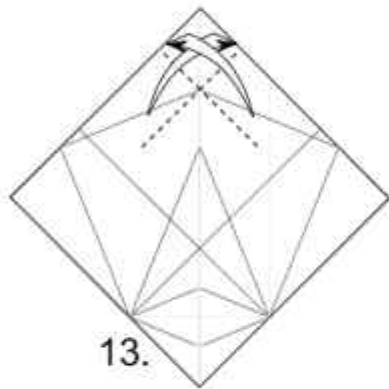
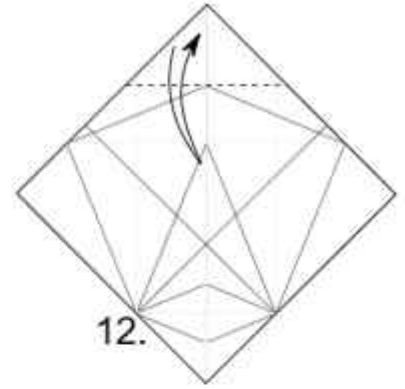
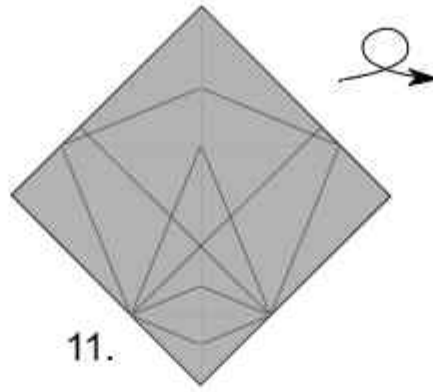
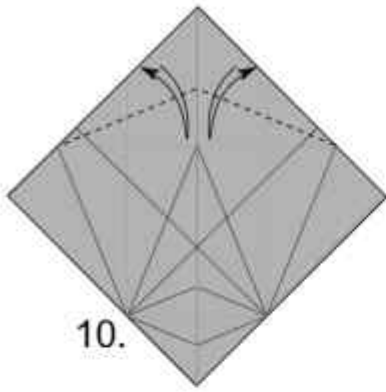

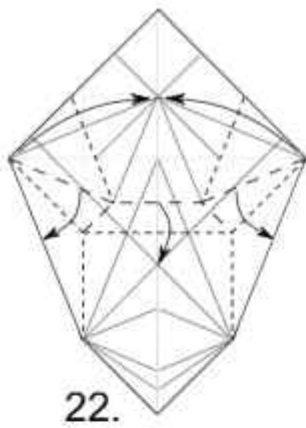

22.

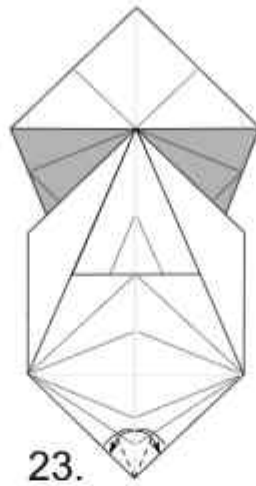

23.

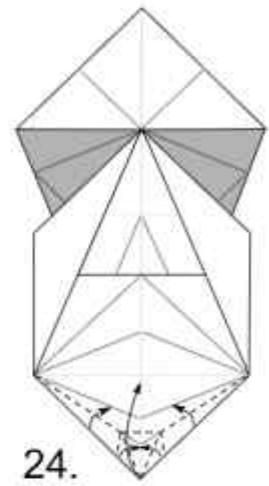

24.

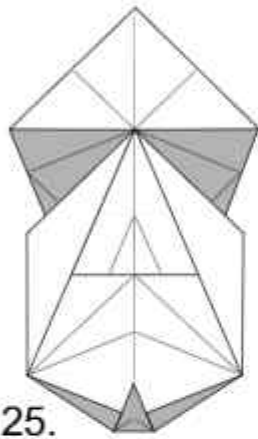

25.

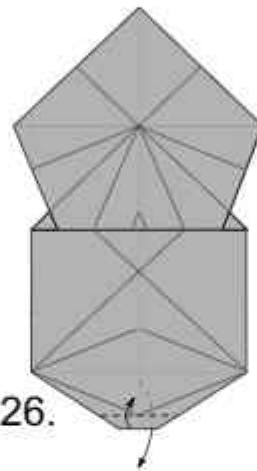

26.

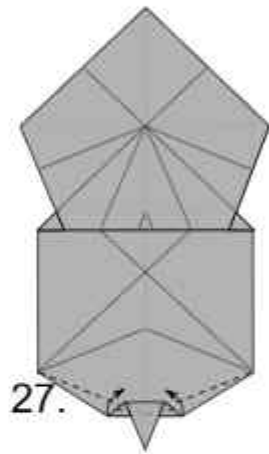

27.

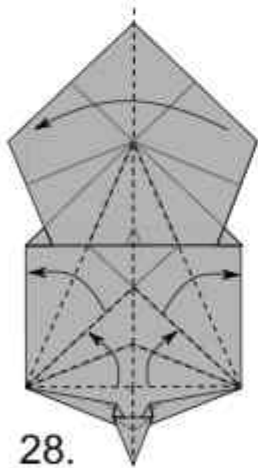

28.

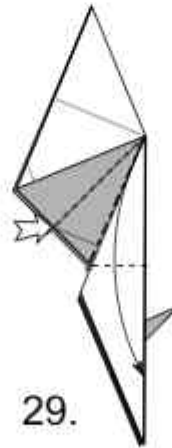

29.

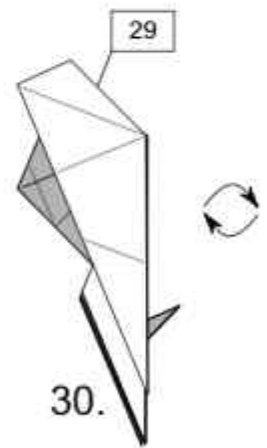

30.

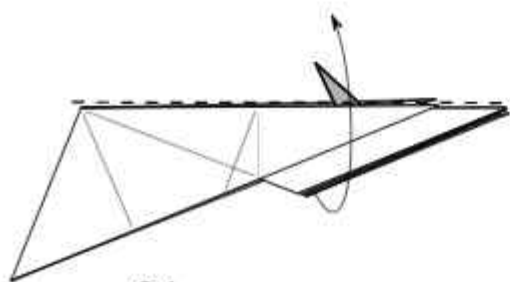

31.

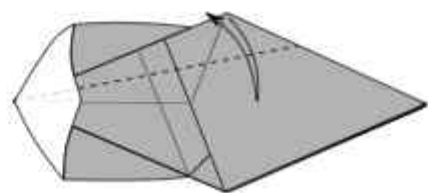

32.

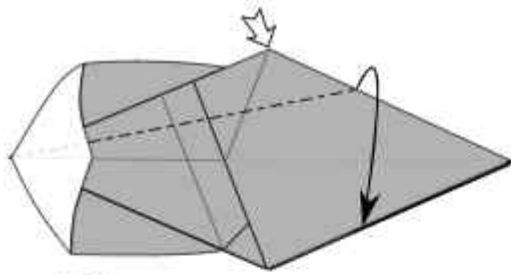

33.

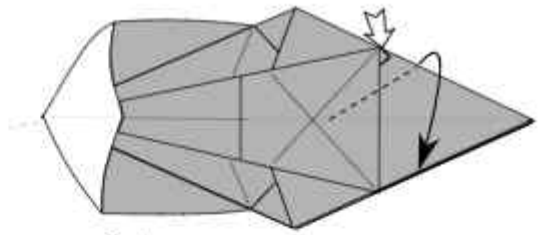

34.

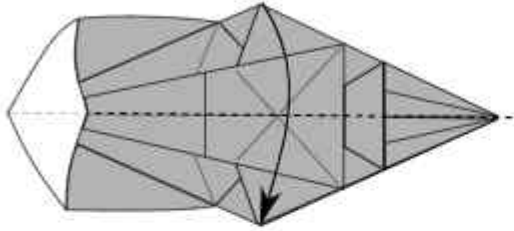

34.

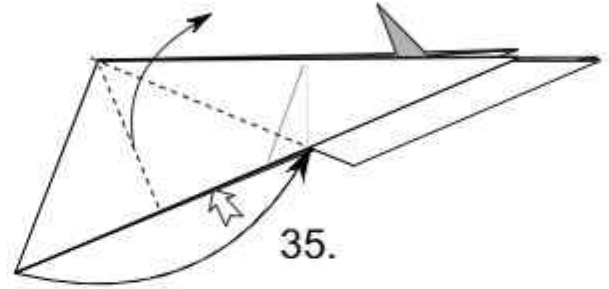

35.

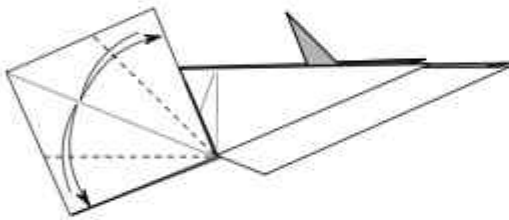

36.

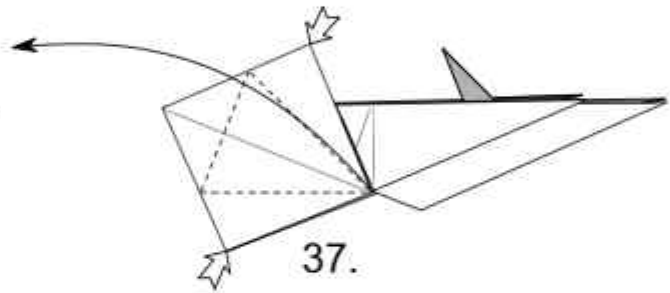

37.



38.

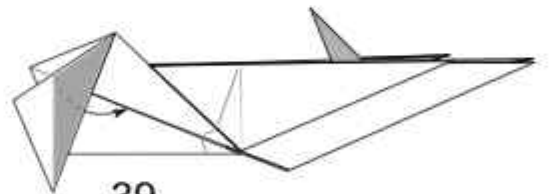

39.

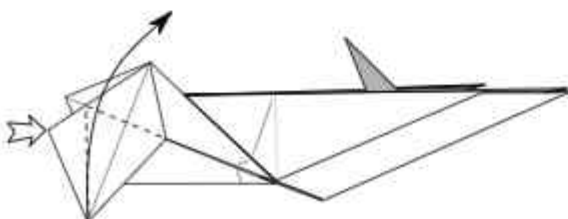

40.

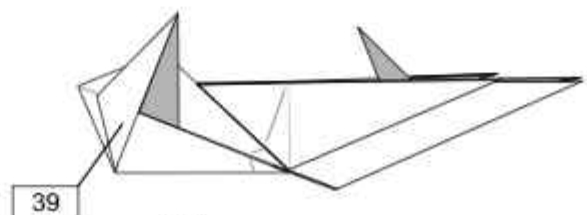

39

41.

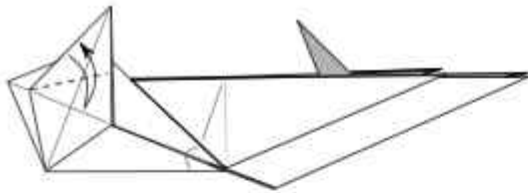

42.

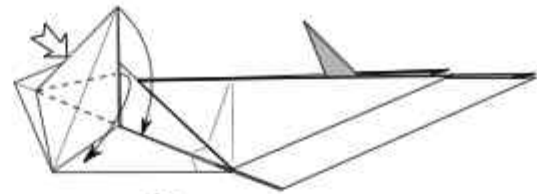

43.

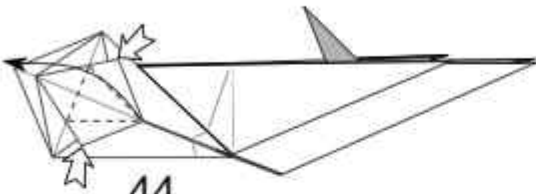

44.

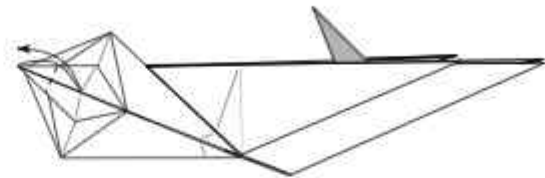

45.

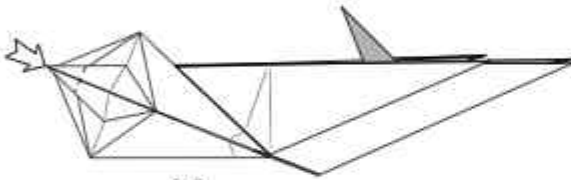

46.

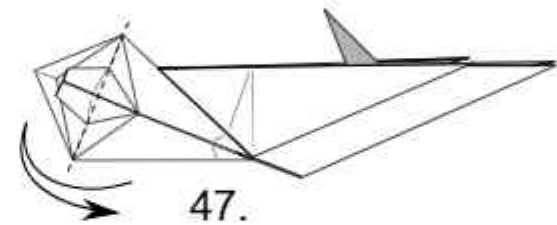

47.

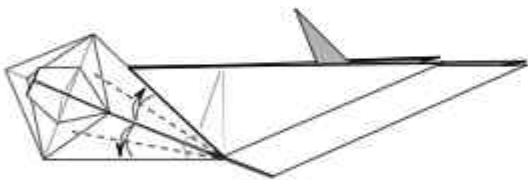

48.

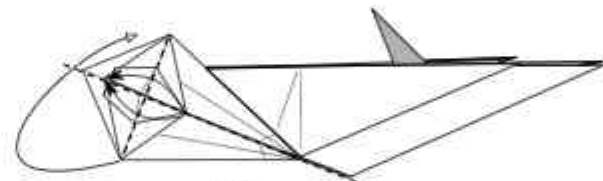

49.



50. De aquí hasta el paso 65 los dobleces deben repetirse simultáneamente en ambos lados.

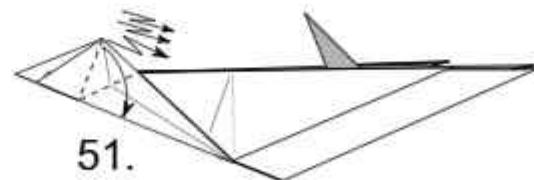

51.

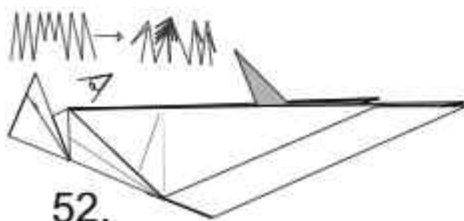

52.



53.

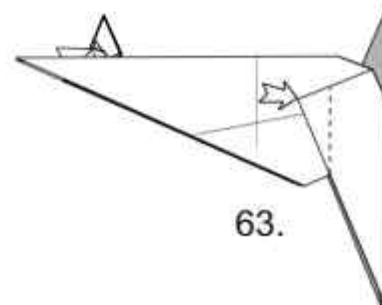
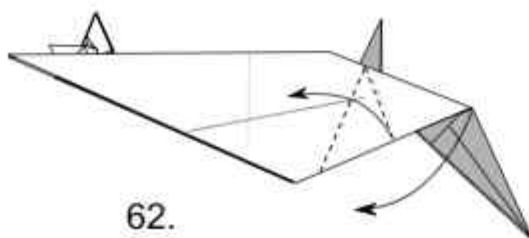
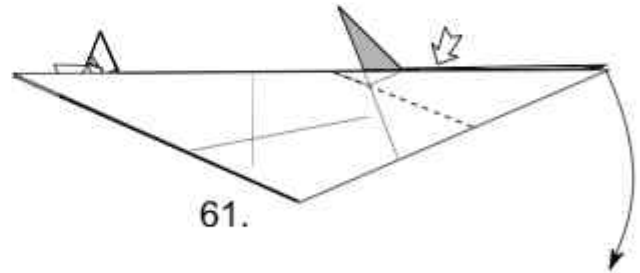
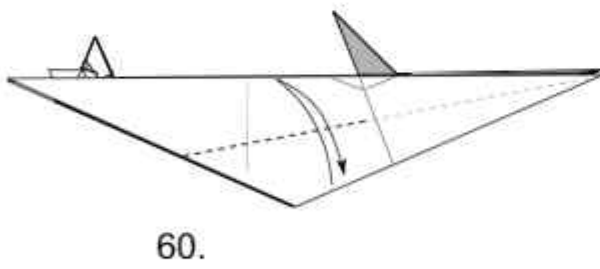
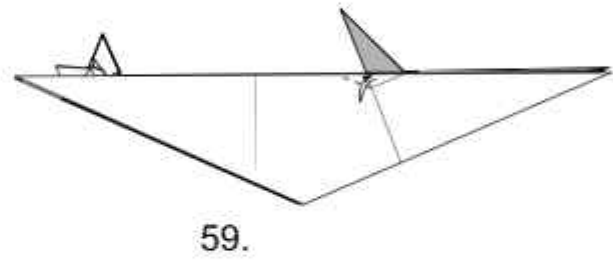
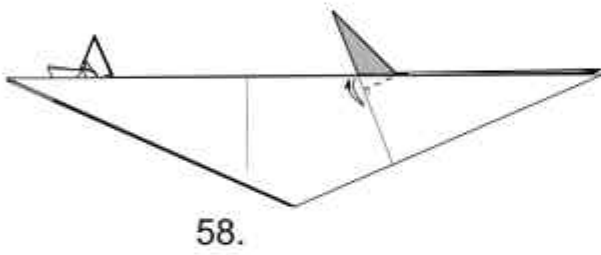
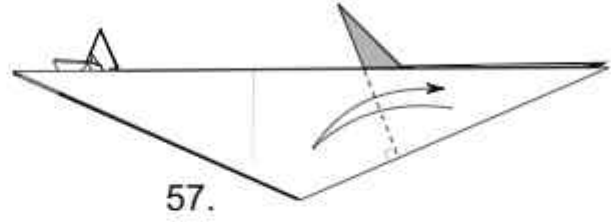
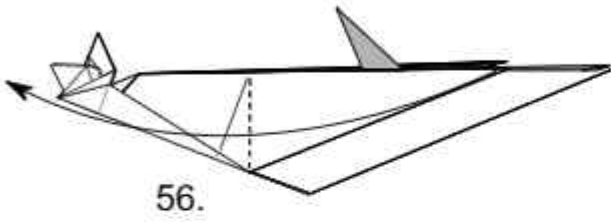
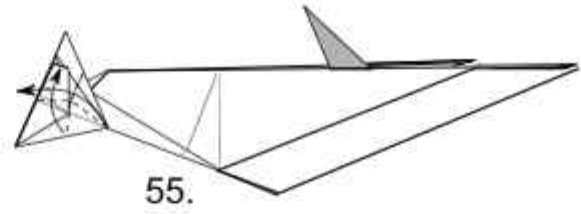
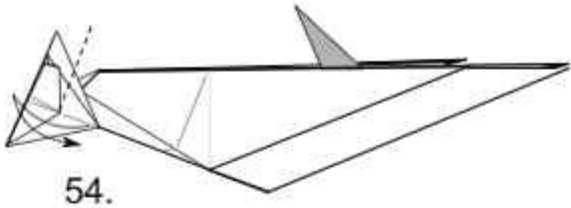

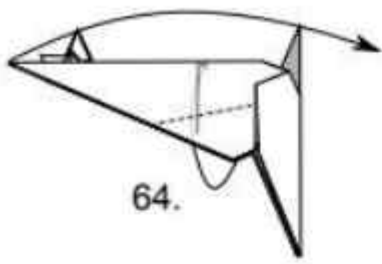

64.

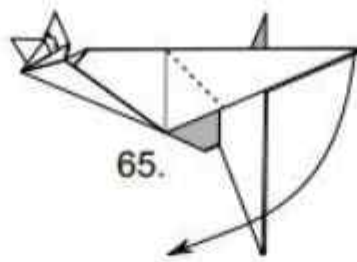

65.

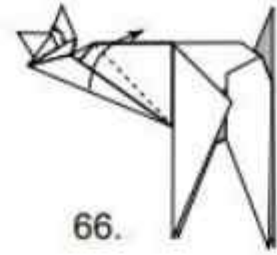

66.



67.



68.



69.

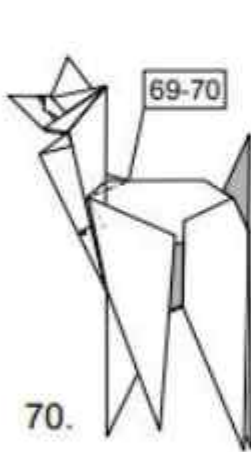

70.

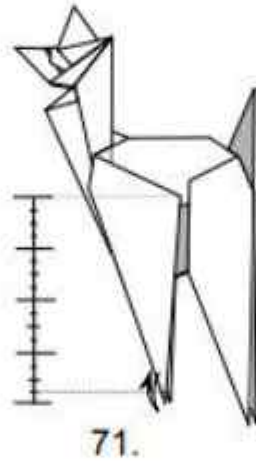

71.

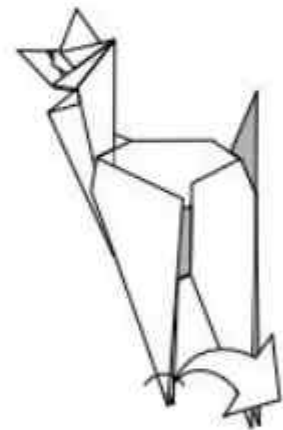

72. Hacer los mismos dobleces en la otra punta.



72a.



72c.

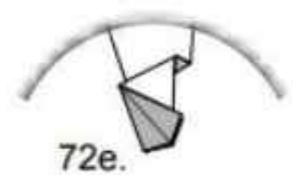

72e.

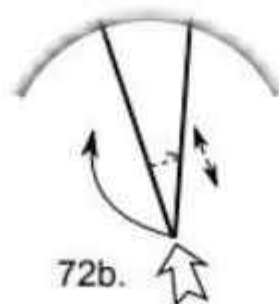

72b.

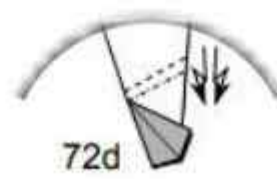

72d.

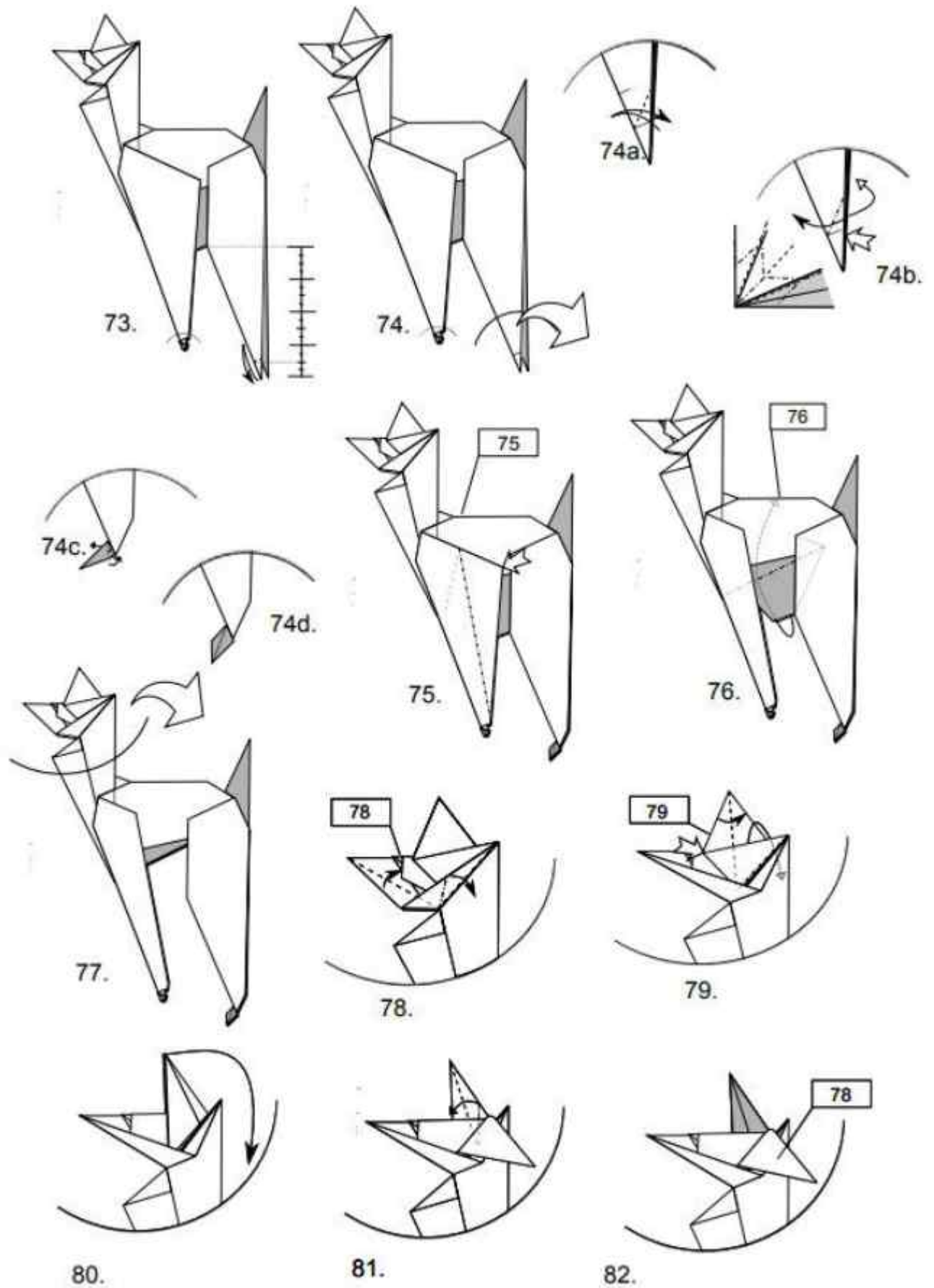

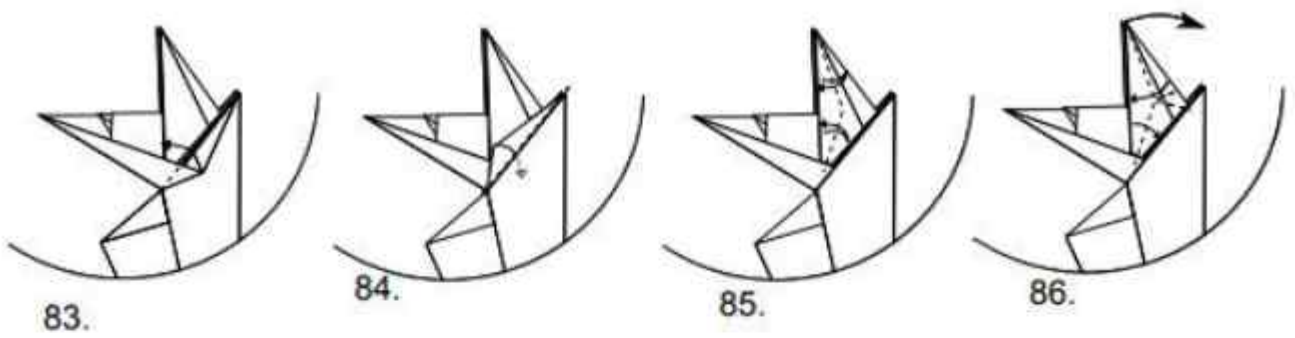

83.

84.

85.

86.

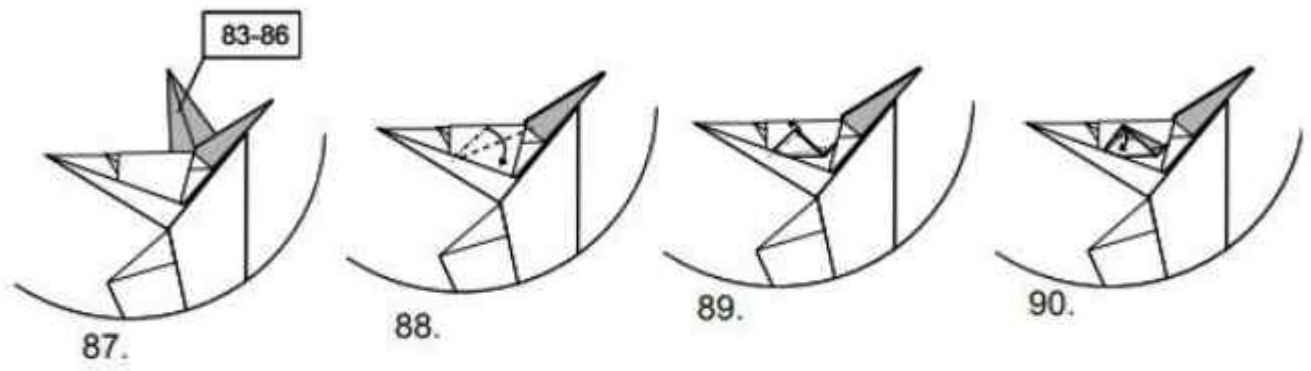

83-86

87.

88.

89.

90.

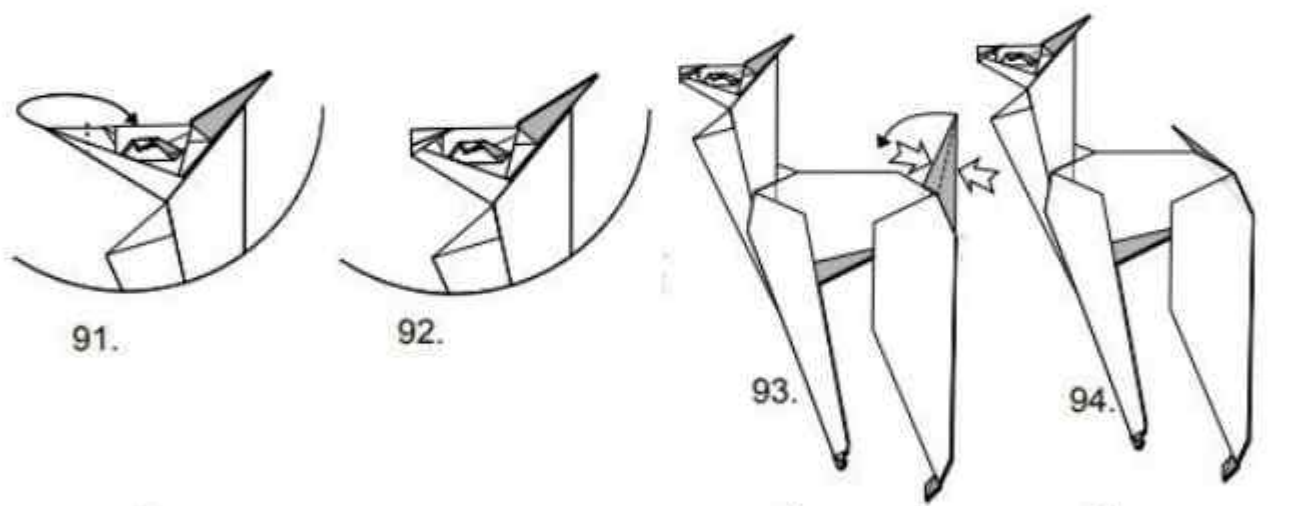

91.

92.

93.

94.

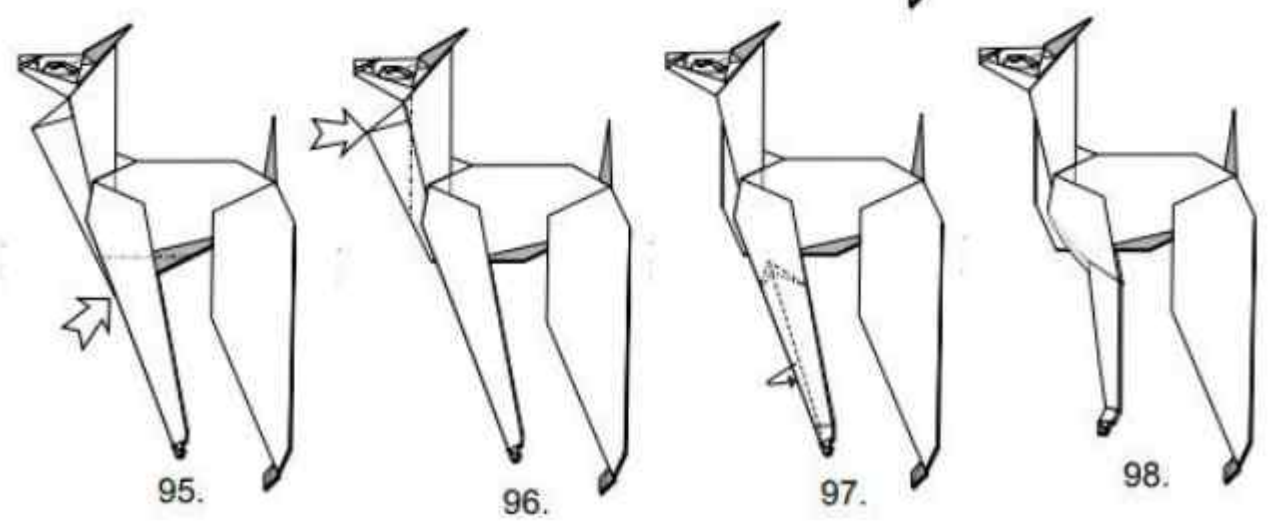

95.

96.

97.

98.

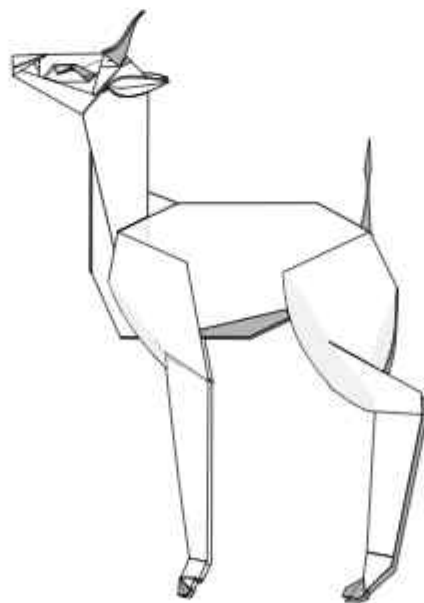
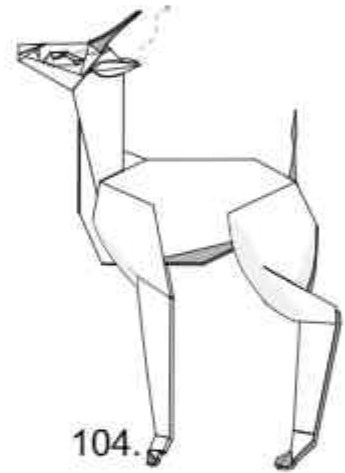
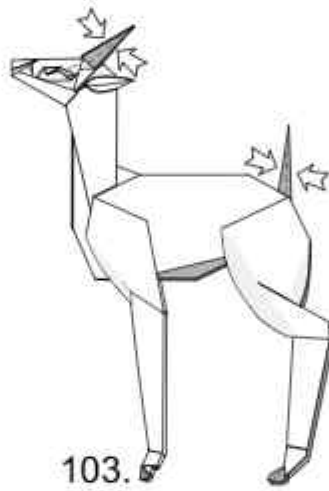
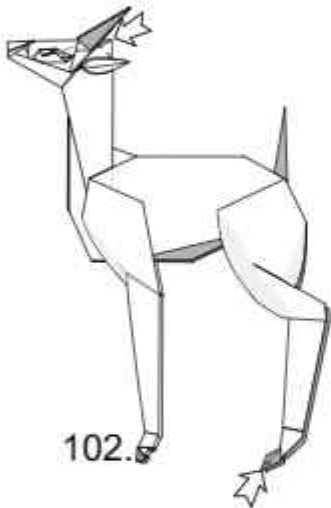
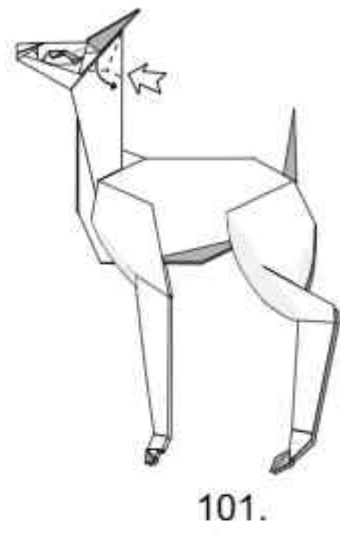
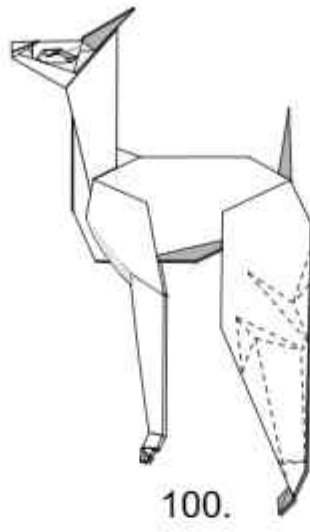
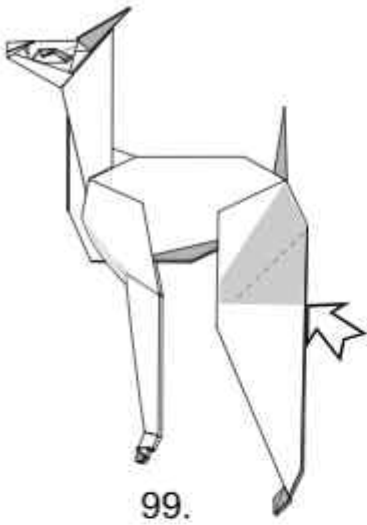

Modelo terminado.

Mandala Marielita / David Martínez

@david_paperfold | 2022

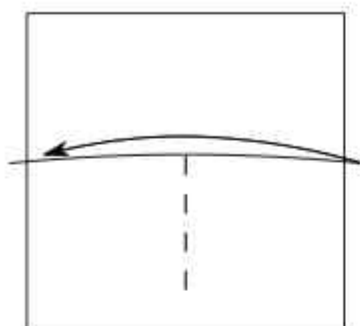

1.- Pellizcar la mitad inferior.

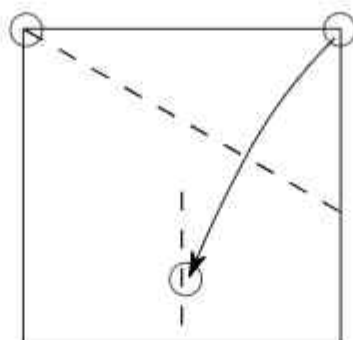

2.- Plegar por las referencias.

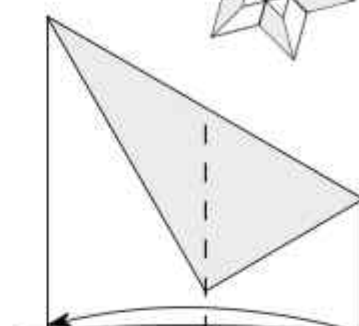

3.- Doblar y desdoblar.

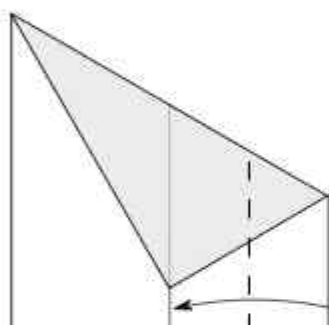

4.- Plegar a la mitad.

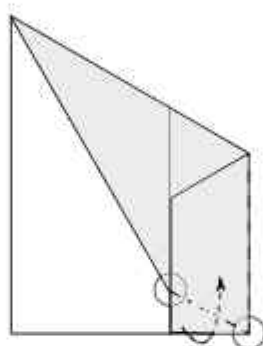

5.- Plegar la punta hacia atrás.

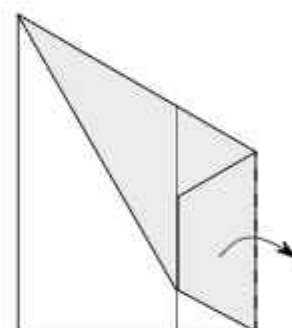

6.- Desplegar.

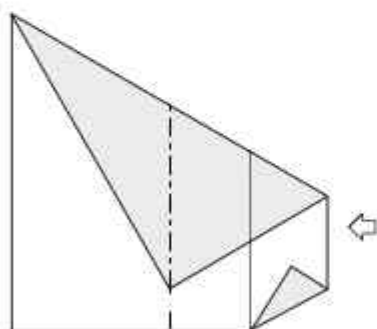

7.- Invertir el doblez.



8.- Hacer 6 módulos.

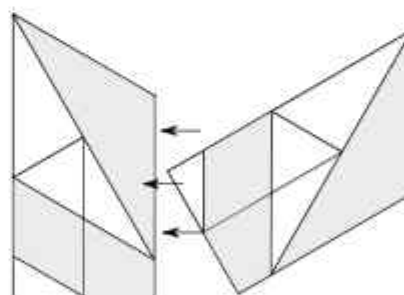

10.- introducir solamente la capa de atrás en el bolsillo.

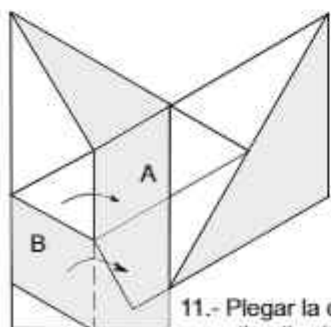

11.- Plegar la capa B en valle, llevándola detrás de la capa A.

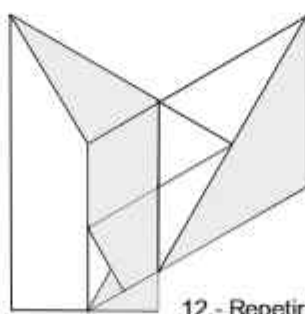

12.- Repetir hasta completar.

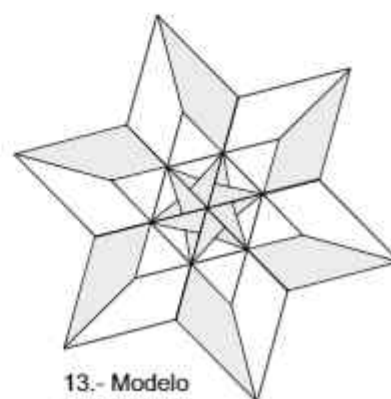

13.- Modelo Completado.

Tesela / David Martínez

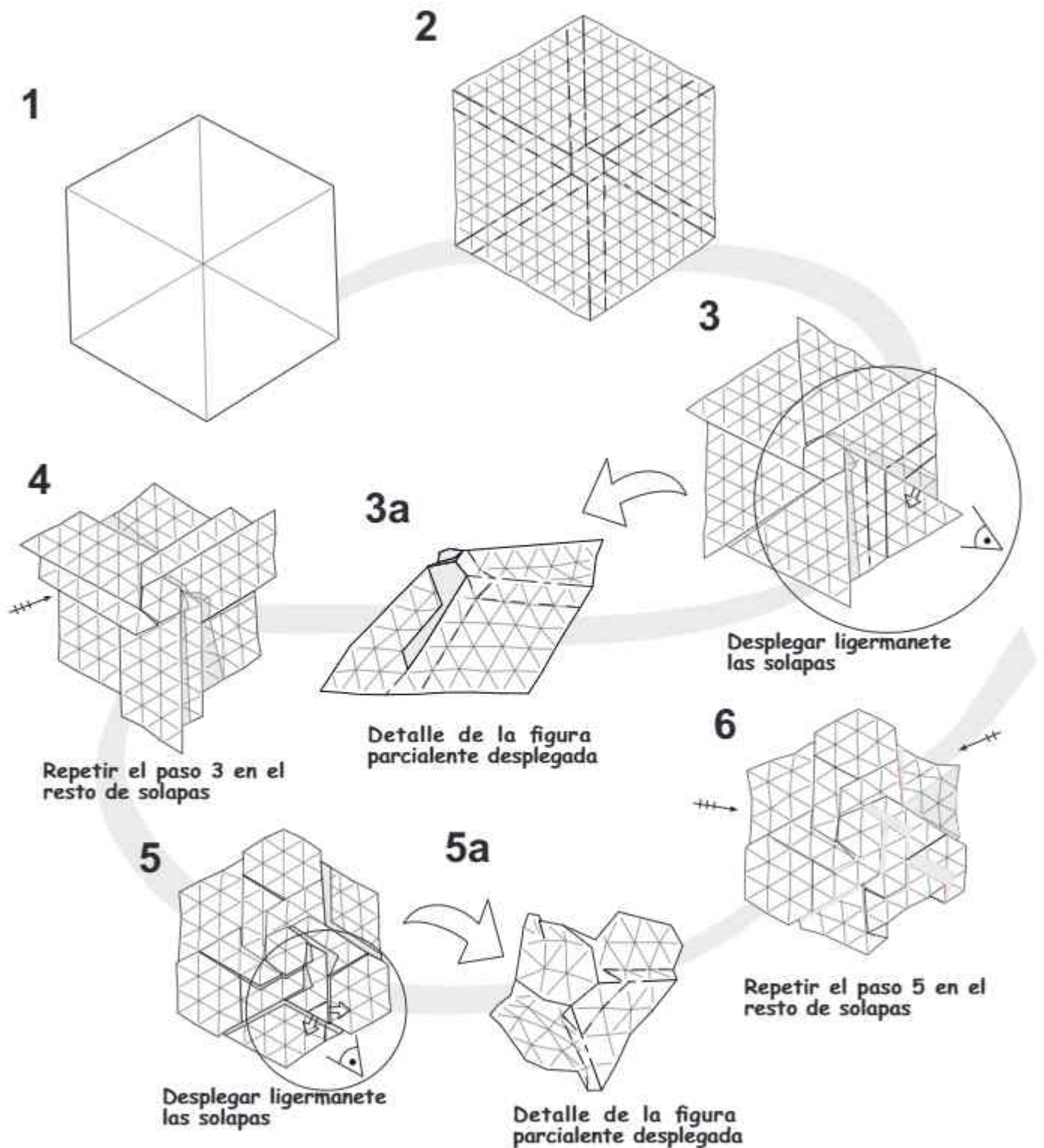

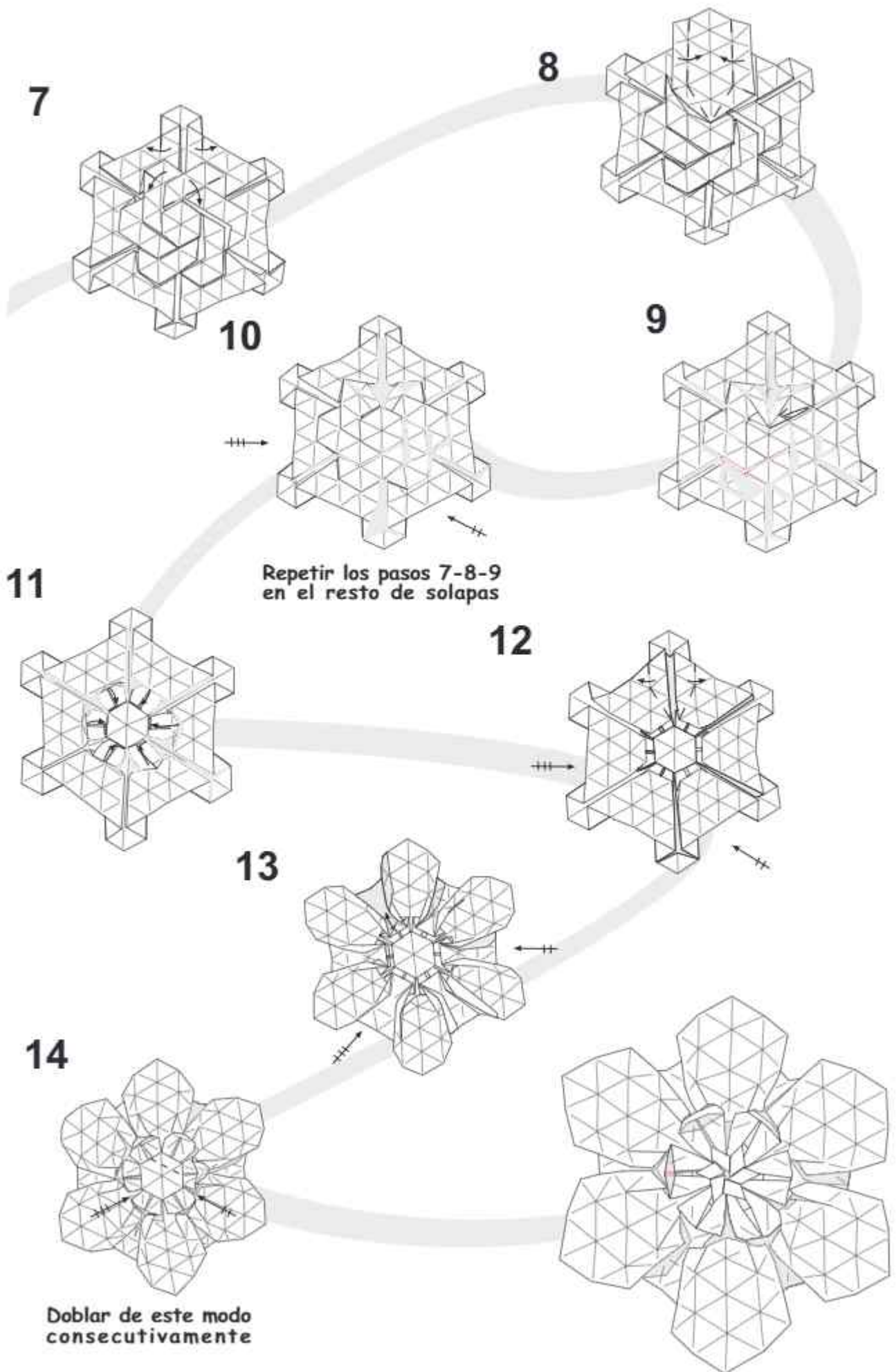

Verum Flower / David Martínez

David Martínez | Venezuela 2012 @david_paperfold

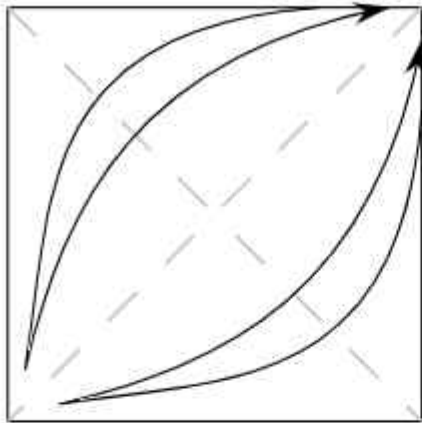

1- Plegar las diagonales

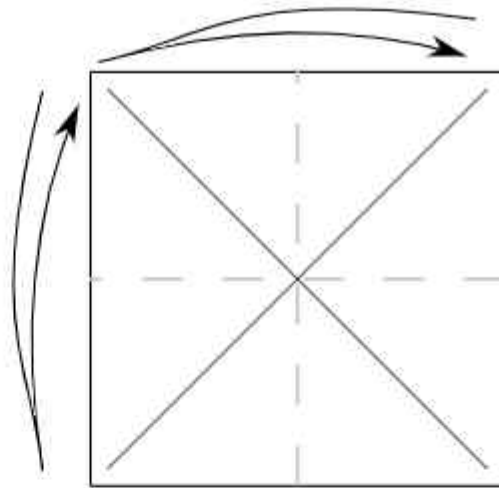

2- Dividir en 2 partes.

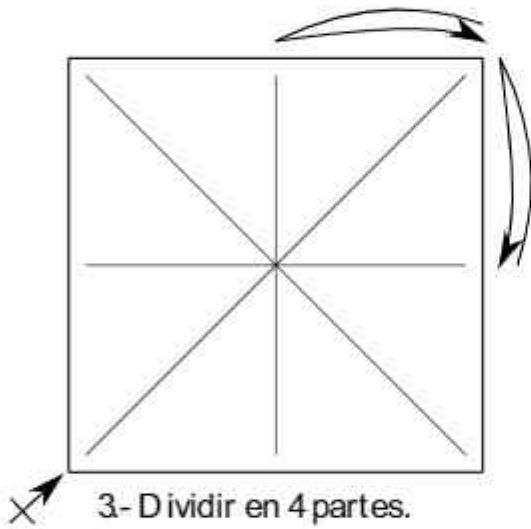

3- Dividir en 4 partes.

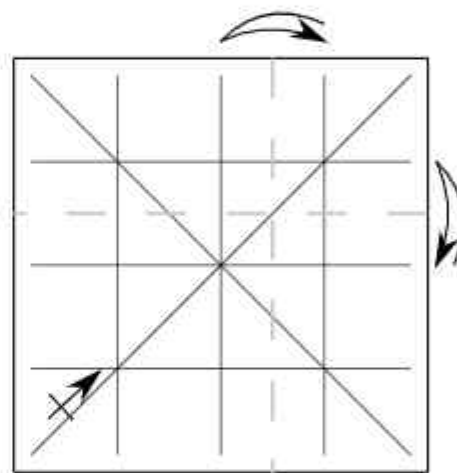

4- Dividir en 8 partes
solo el centro.

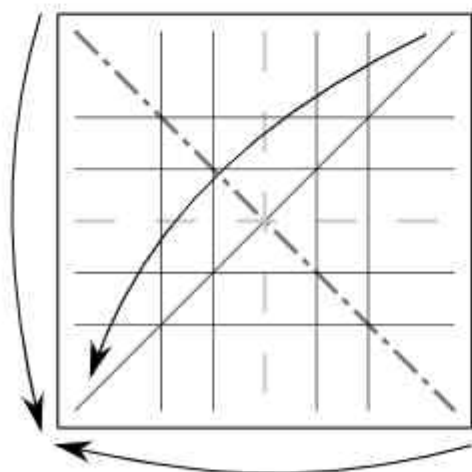

5- Plegar una base
preliminar.

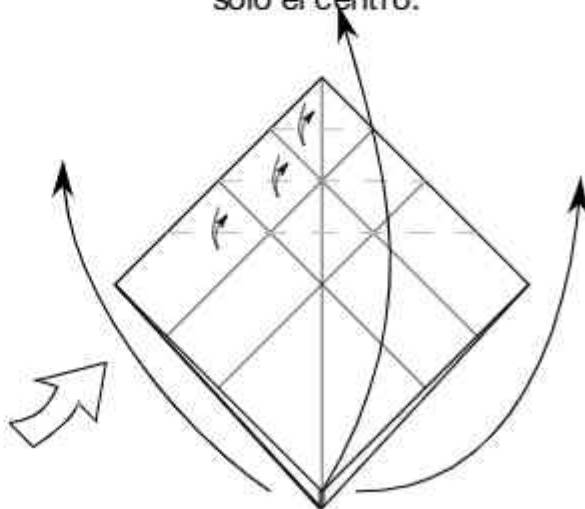

6- Dividir en tercios la
parte superior como se indica.

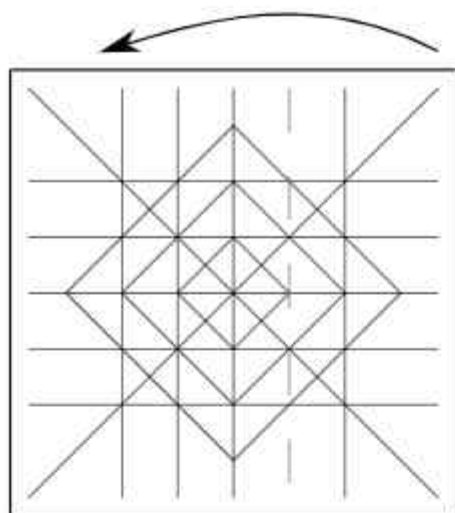

7.-Plegar la línea indicada en valle.

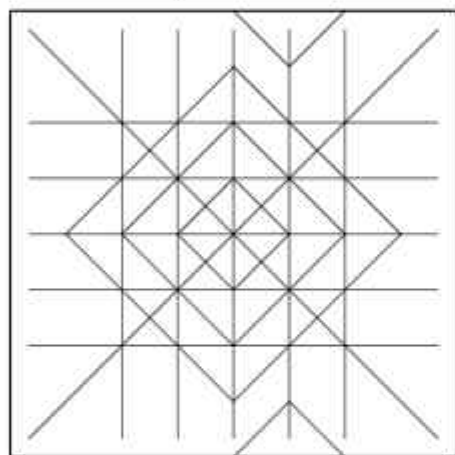

9.-Repetir 7 y 8 simetricamente en el lado izquierdo.

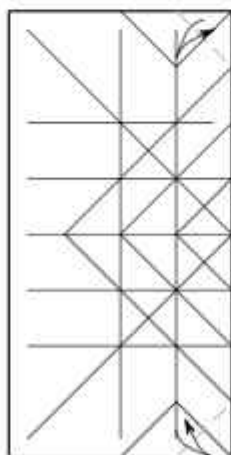

11.-Plegar unas diagonales en la parte superior e inferior del modelo y desdoblar.

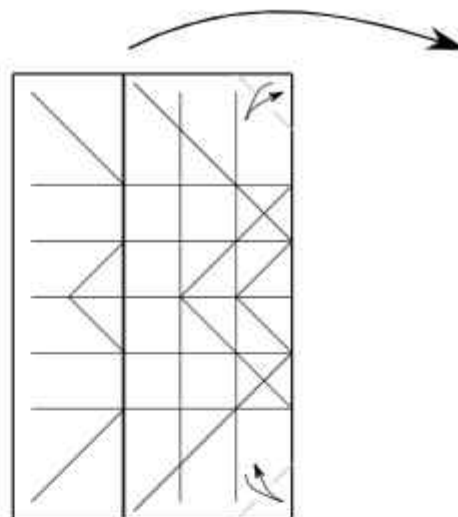

8.-Plegar diagonales en la parte superior e inferior.

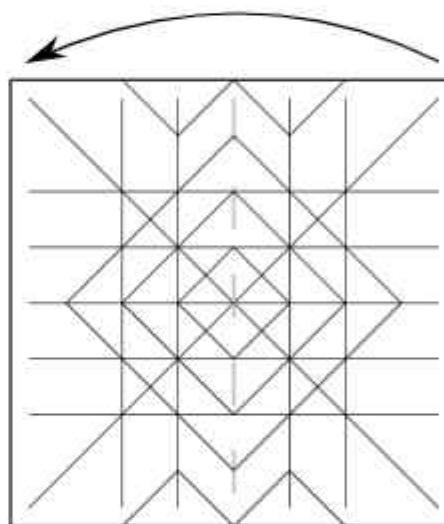

10.-Plegar de nuevo a la mitad.

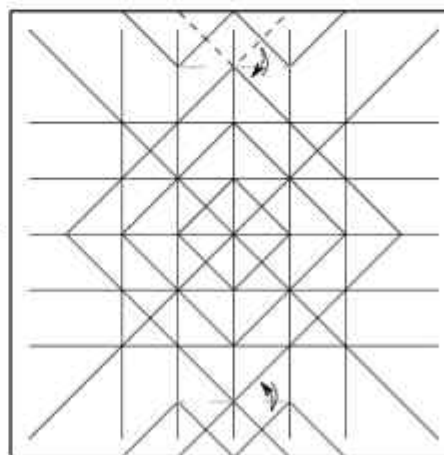

12.-marcar horizontales y repetir analogamente al otro lado pasos 7 a 11.

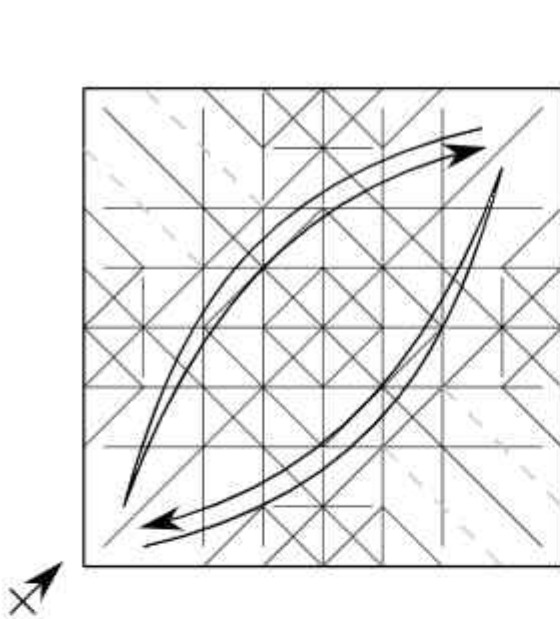

13. Marcar diagonales hasta donde se indica y repetir al otro lado.

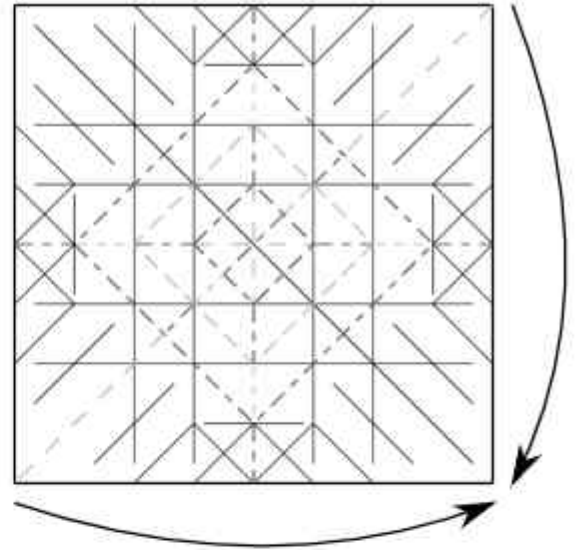

14. Colapsar como se muestra parecido a una base preliminar.

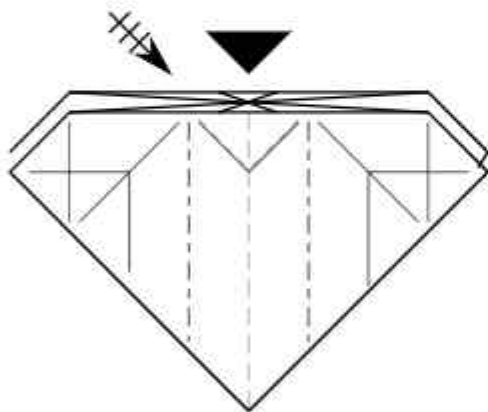

15. Hundir el triángulo interno en cada centro.
El modelo se hace 3D.

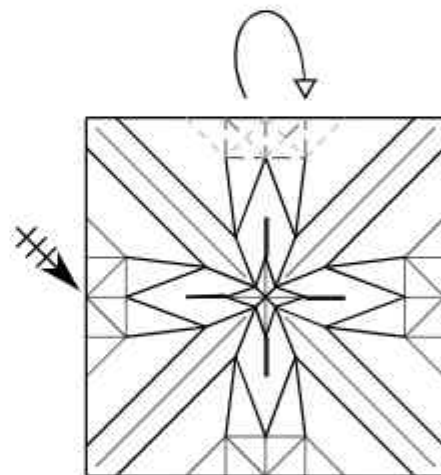

16. Hundir hacia atrás como se muestra, generando el cierre del modelo.

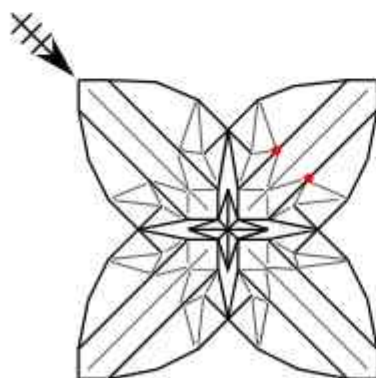

17. Modelar la flor hundiendo en las marcas y elevando cada pétalo.

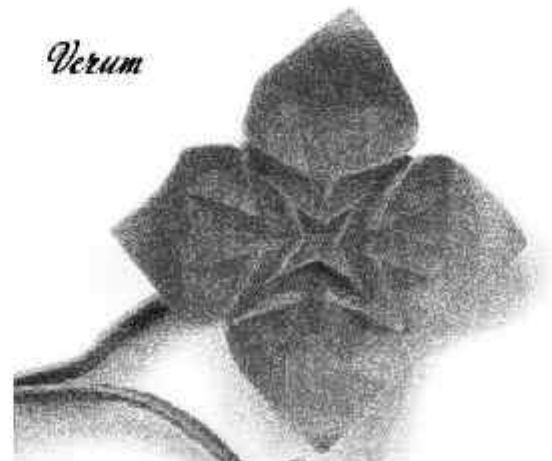

Verum



**ORIGAMI
ARGENTINA**
Asociación Civil
Plegando al Sur

www.origamiargentina.org

✉ info.origami.argentina@gmail.com

📷 [@origamiargentinaoficial](https://www.instagram.com/origamiargentinaoficial)