

Alien

Model and diagram
by Damian Malicki

Recommended paper
size: 35 cm x 35 cm

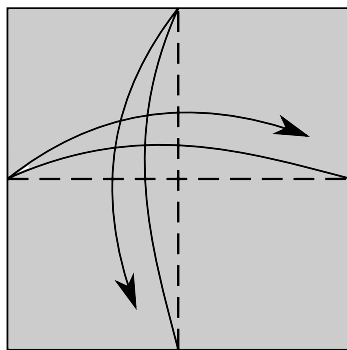
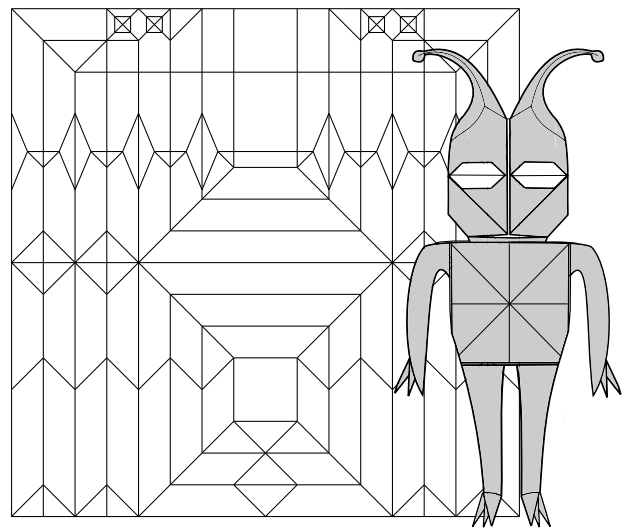

1. Fold and unfold.

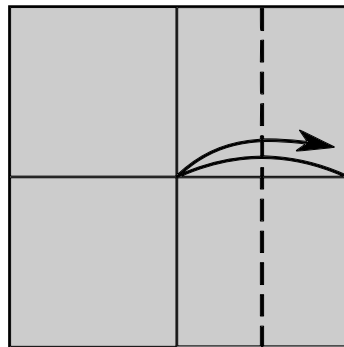

2. Fold and unfold.

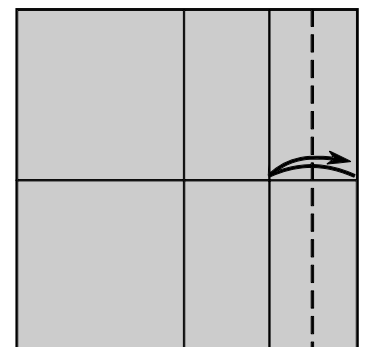

3. Fold and unfold.

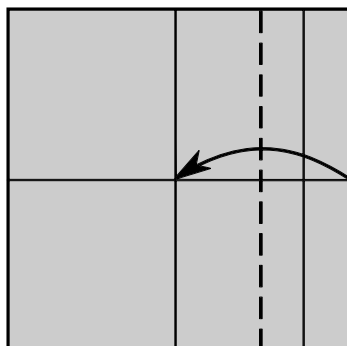

4. Fold to the center line.

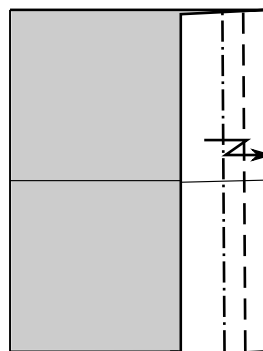

5. Crimp.

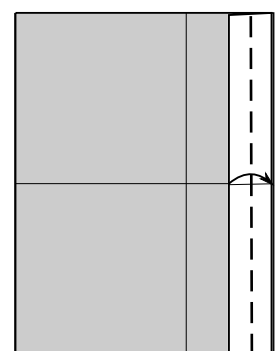

6. Fold to the edge.

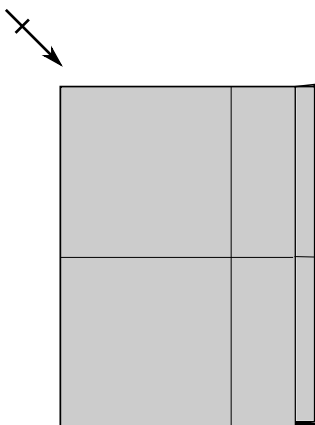

7. Repeat steps
2-6 on the left.

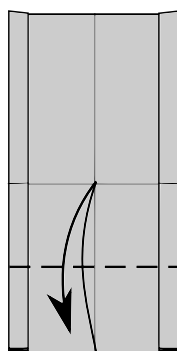

8. Fold and
unfold. Turn the
paper over.

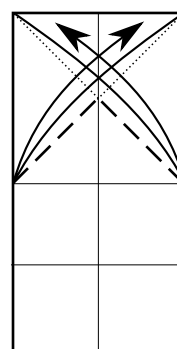

9. Fold and
unfold diagonals.

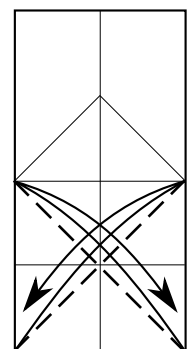

10. Fold and
unfold diagonals.

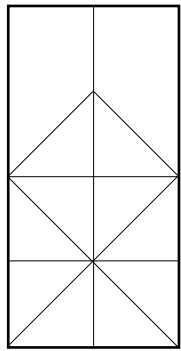

11. Turn the paper over.

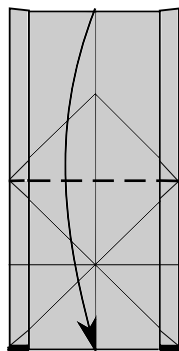
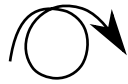

12. Fold down.

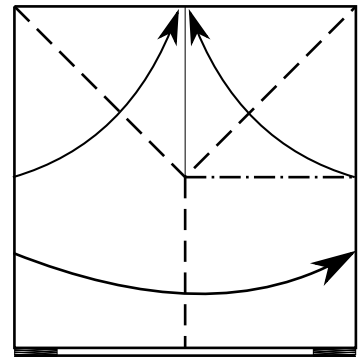
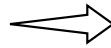

13. Fold rabbit ear.

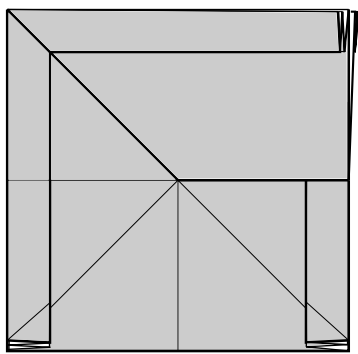

14. Turn the paper over.

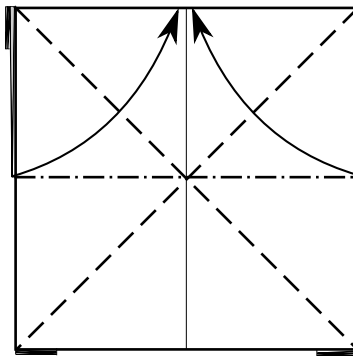

15. Fold waterbomb base.

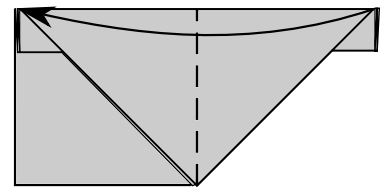

16. Fold the flap to the left.

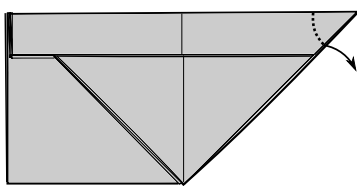

17. Pull out two layers.

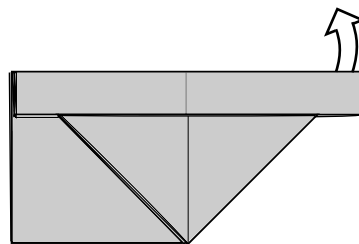

18. Pull out some paper.

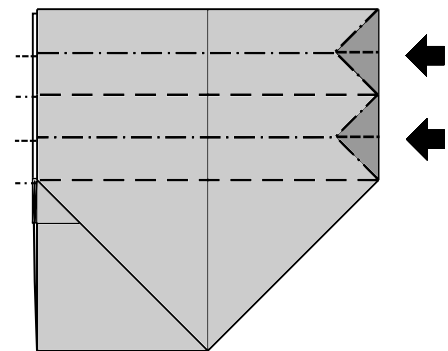

19. Pleat while squashing the darkened area.

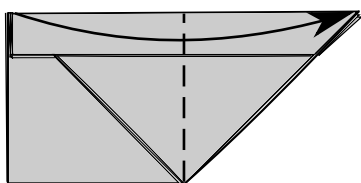

20. Fold the flap to the right.

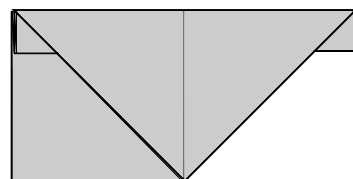

21. Repeat steps 16-20 on the left.

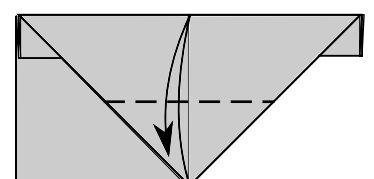

22. Fold the corner and unfold.

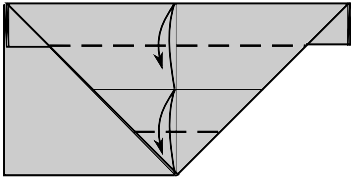

23. Fold and unfold.

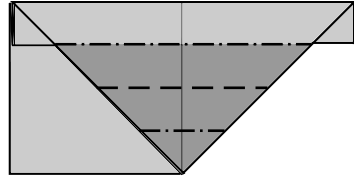

24. Open sink in and out.

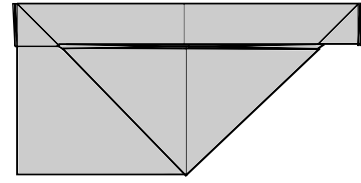

25. Turn the paper over.

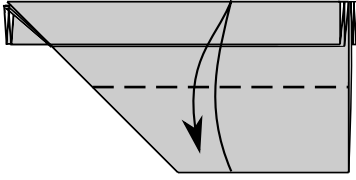

26. Fold and unfold.

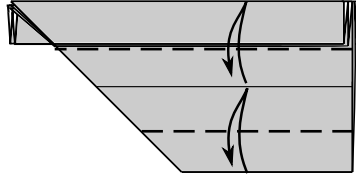

27. Fold and unfold.

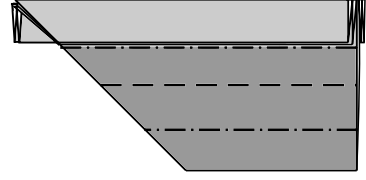

28. Open sink in and out.

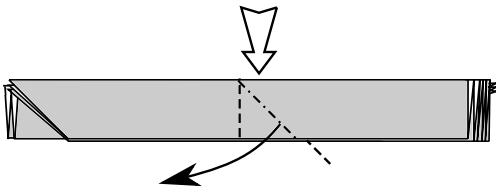

29. Squash the layers.

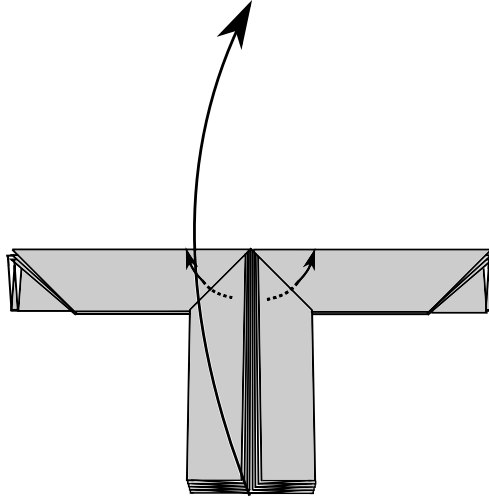

30. Pull out the corners and fold up the layers.

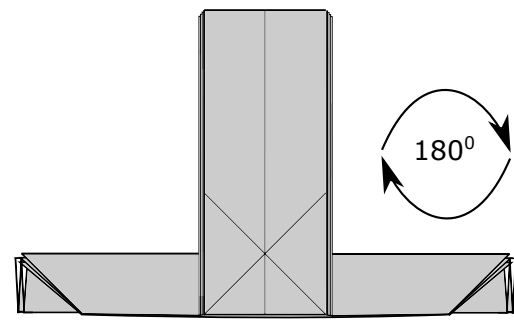

31. Rotate the paper.

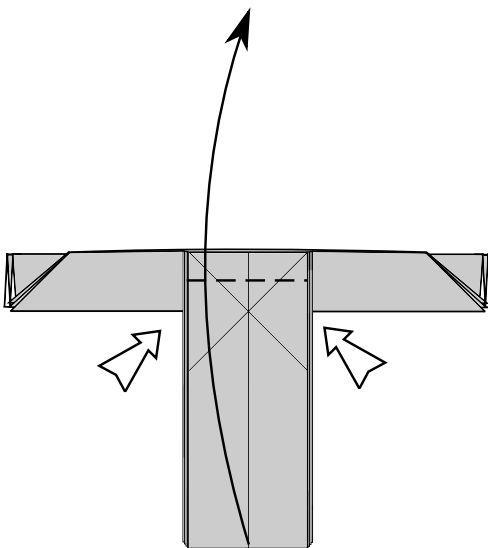

32. Fold up the layer while squashing the paper.

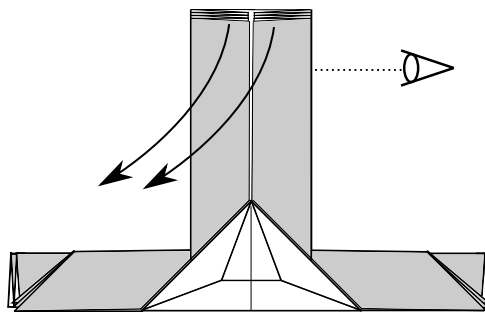

33. Open the layers. Look from the side.

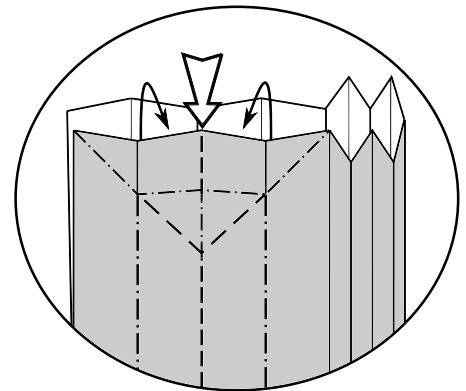

34. Pleat the edge as shown.

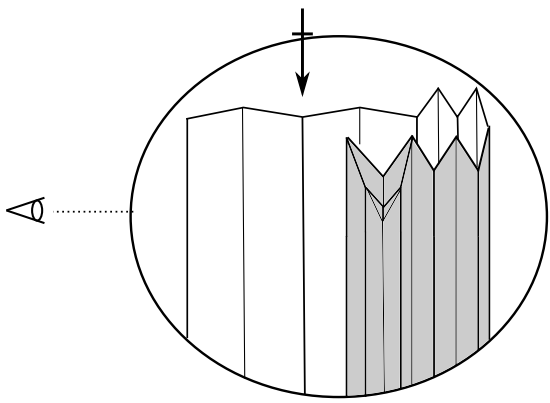

35. Repeat behind. Back to the top view.

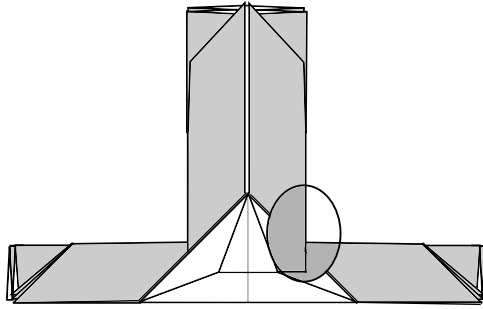

36. Look inside.

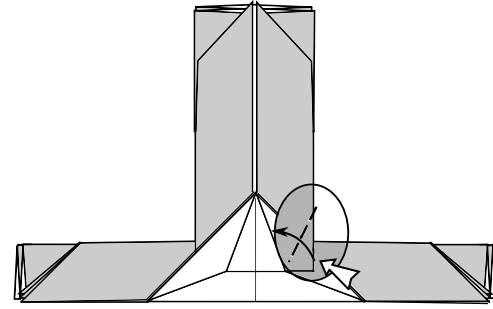

37. Squash the paper.

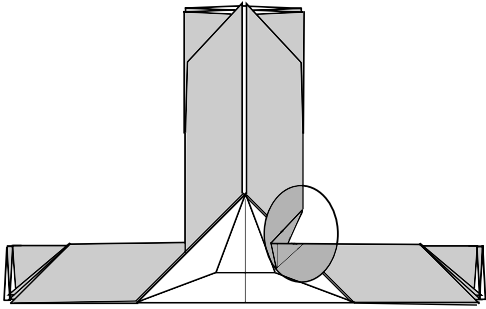

38. Like this.

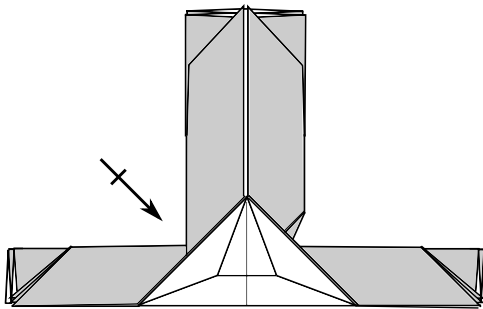

39. Repeat steps 36-38 on the left.

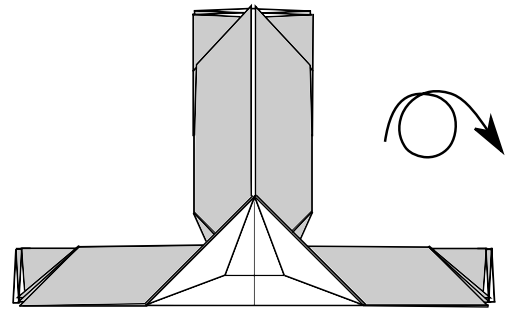

40. Turn the paper over.

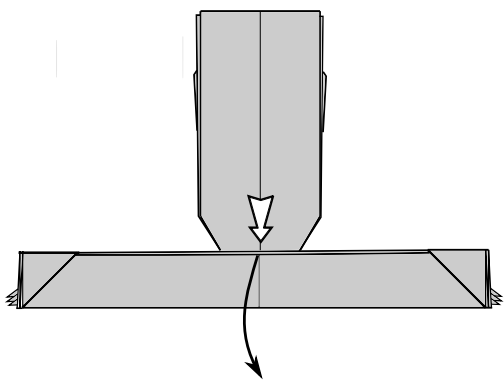

41. Fold the layers down while squashing the middle square.

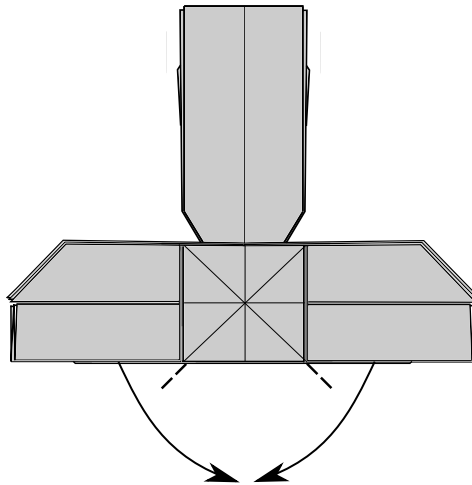

42. Fold the legs down.

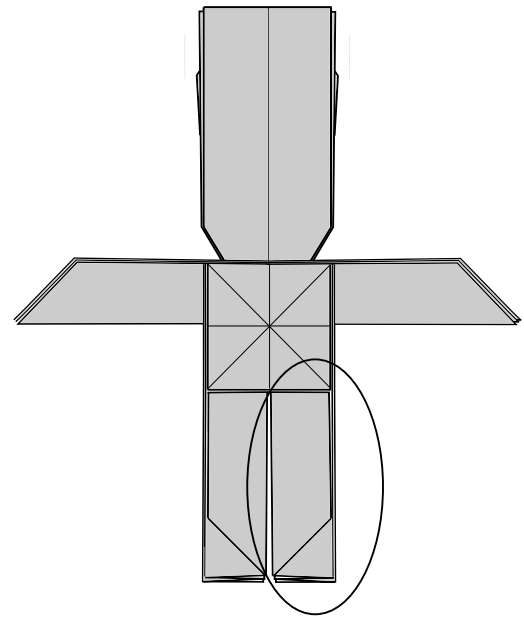

43. Zoom in.

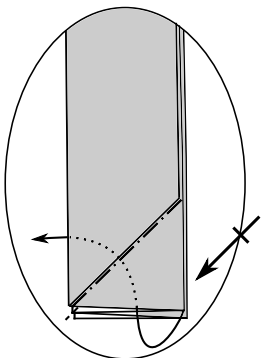

44. Inside reverse fold. Repeat on the next layer.

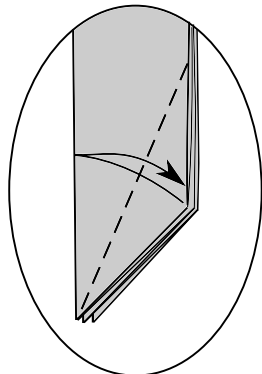

45. Fold and unfold bisector.

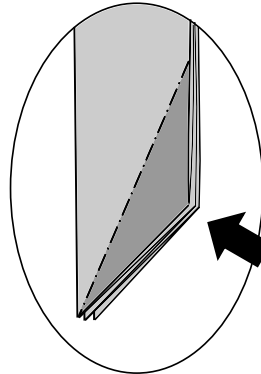

46. Open sink.

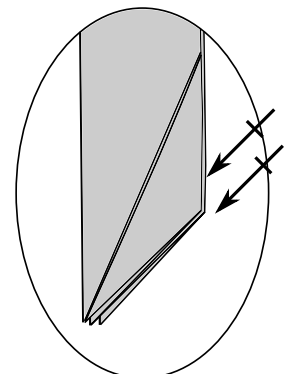

47. Repeat steps 45-46 on the next next two layers.

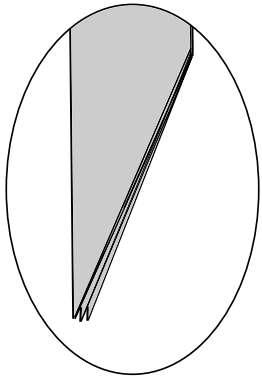

48. Like this. Zoom out.

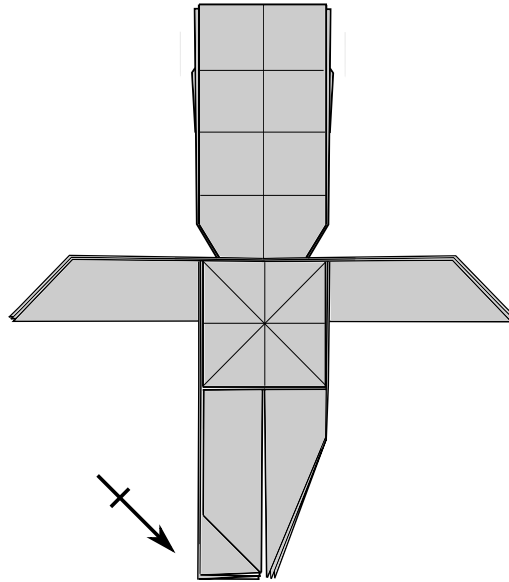

49. Repeat steps 43-48 on the left.

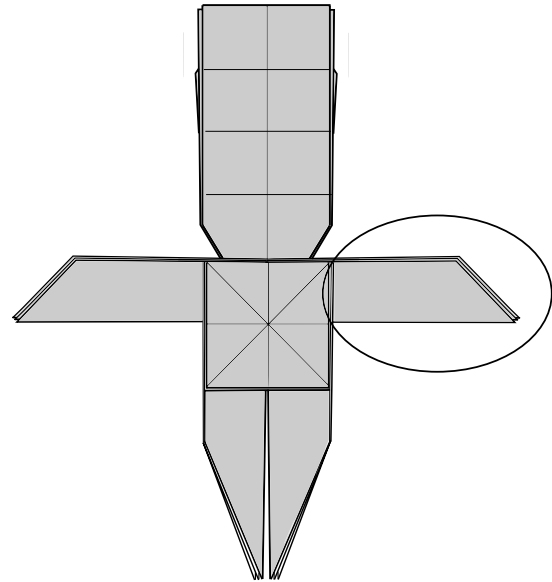

50. Zoom in.

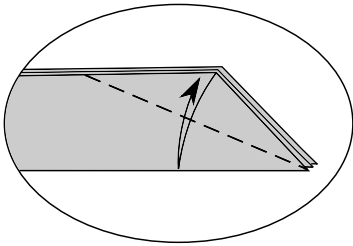

51. Fold and unfold bisector.

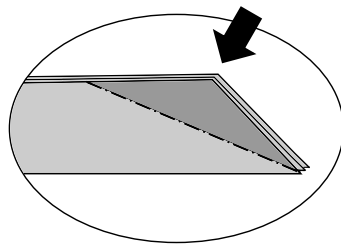

52. Open sink.

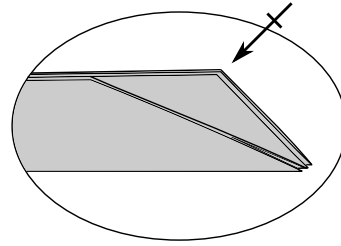

53. Repeat steps 51-52 on the next five flaps.

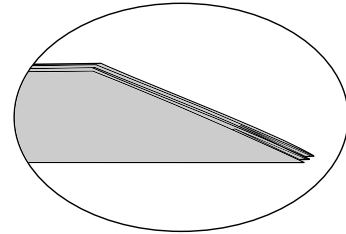

54. Like this. Zoom out.

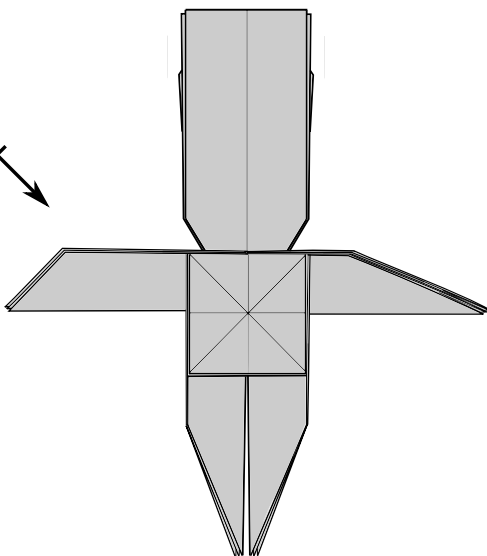

55. Repeat steps 50-54 on the left.

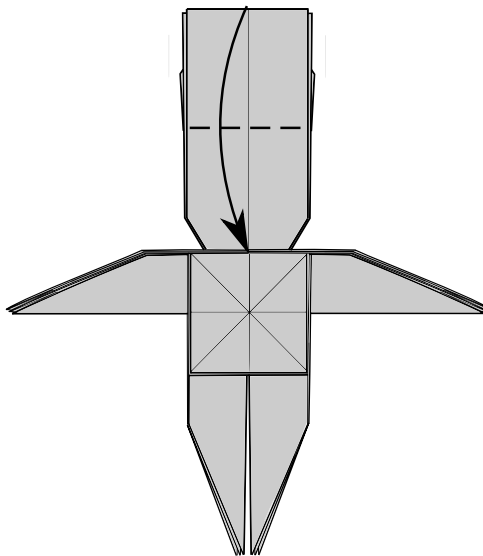

56. Fold the layers down.

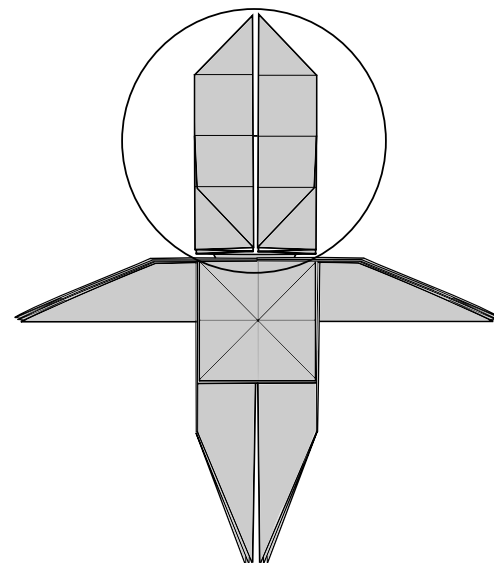

57. Zoom in.

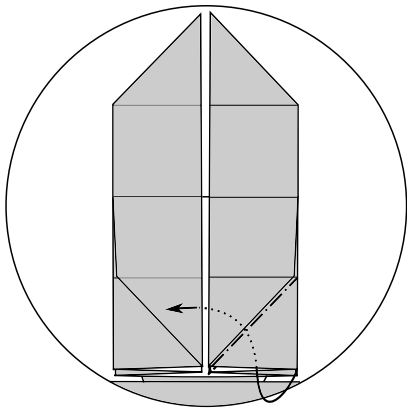

58. Inside reverse fold.

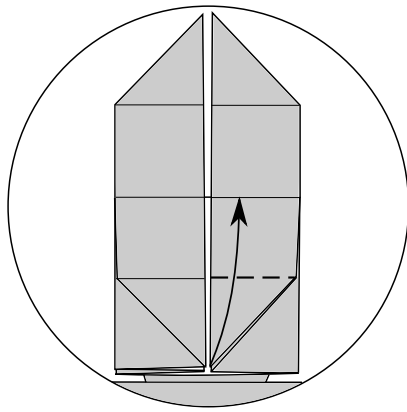

59. Fold the flap up.

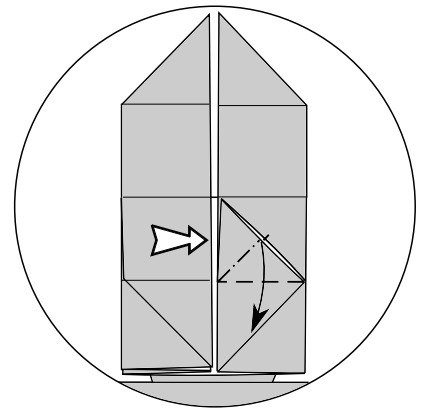

60. Squash fold.

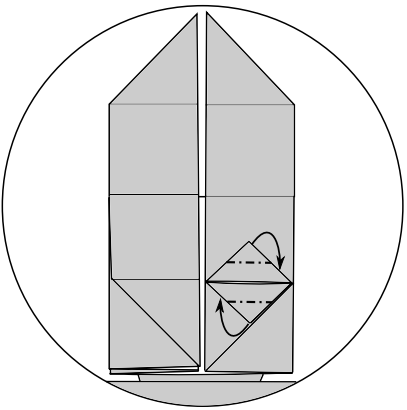

61. Mountain folds on the eyes.

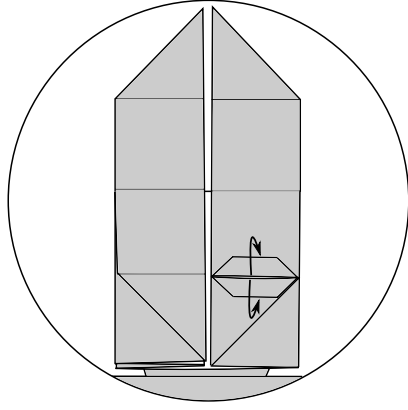

62. Unwrap the layers to make color change.

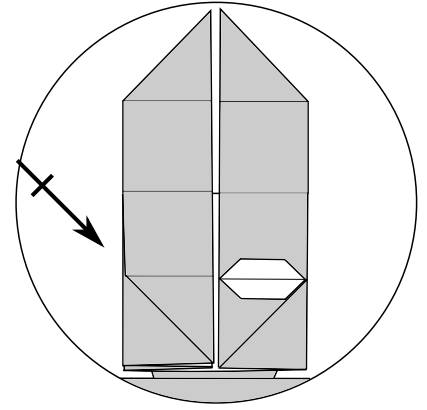

63. Repeat steps 58-62 on the left.

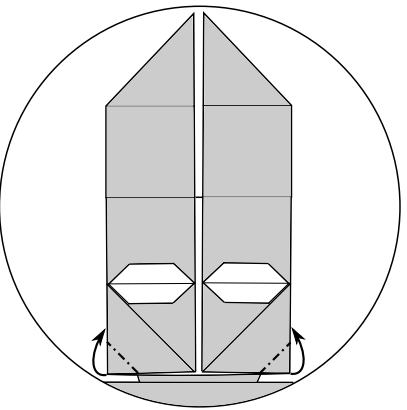

64. Mountain fold the corners.

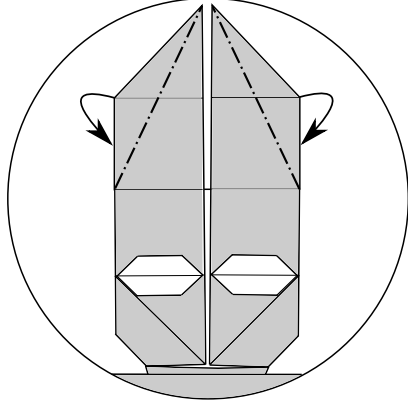

64. Mountain fold the corners.

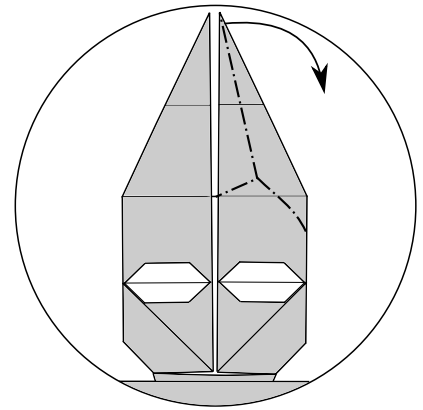

65. Shape the horn.

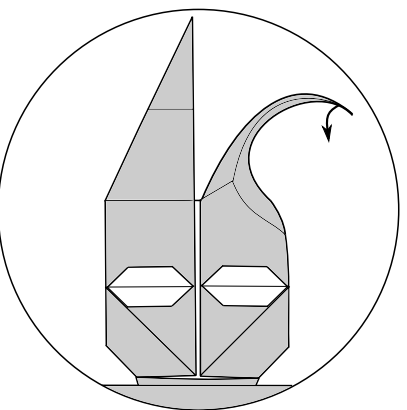

66. Open the paper on the end of the horn.

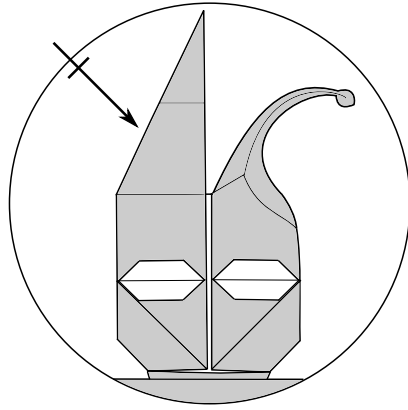

67. Repeat steps 65-66 on the left.

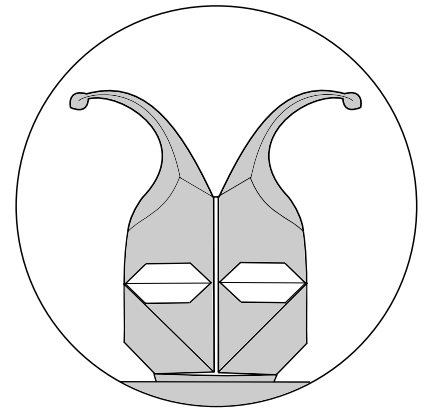

68. Like this. Zoom out.

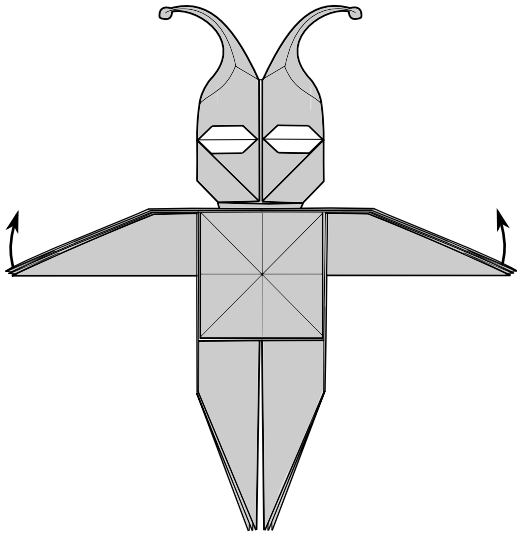

69. Shape the fingers.

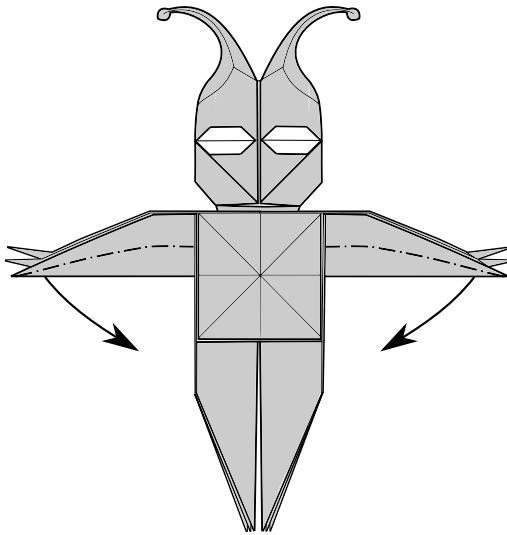

70. Shape the hands.

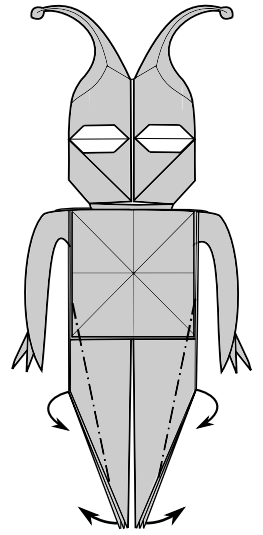

71. Mountain fold on the legs. Shape the fingers.

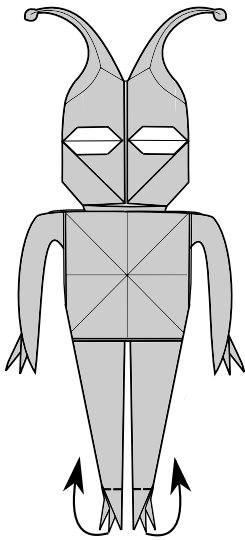

72. Shape the toes.

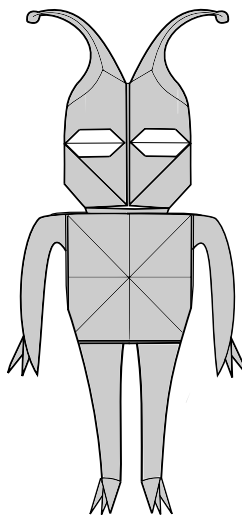

73. Alien is completed.