

종이접기 매니아를 위한

ORIGAMI PRO

동물 종이접기편

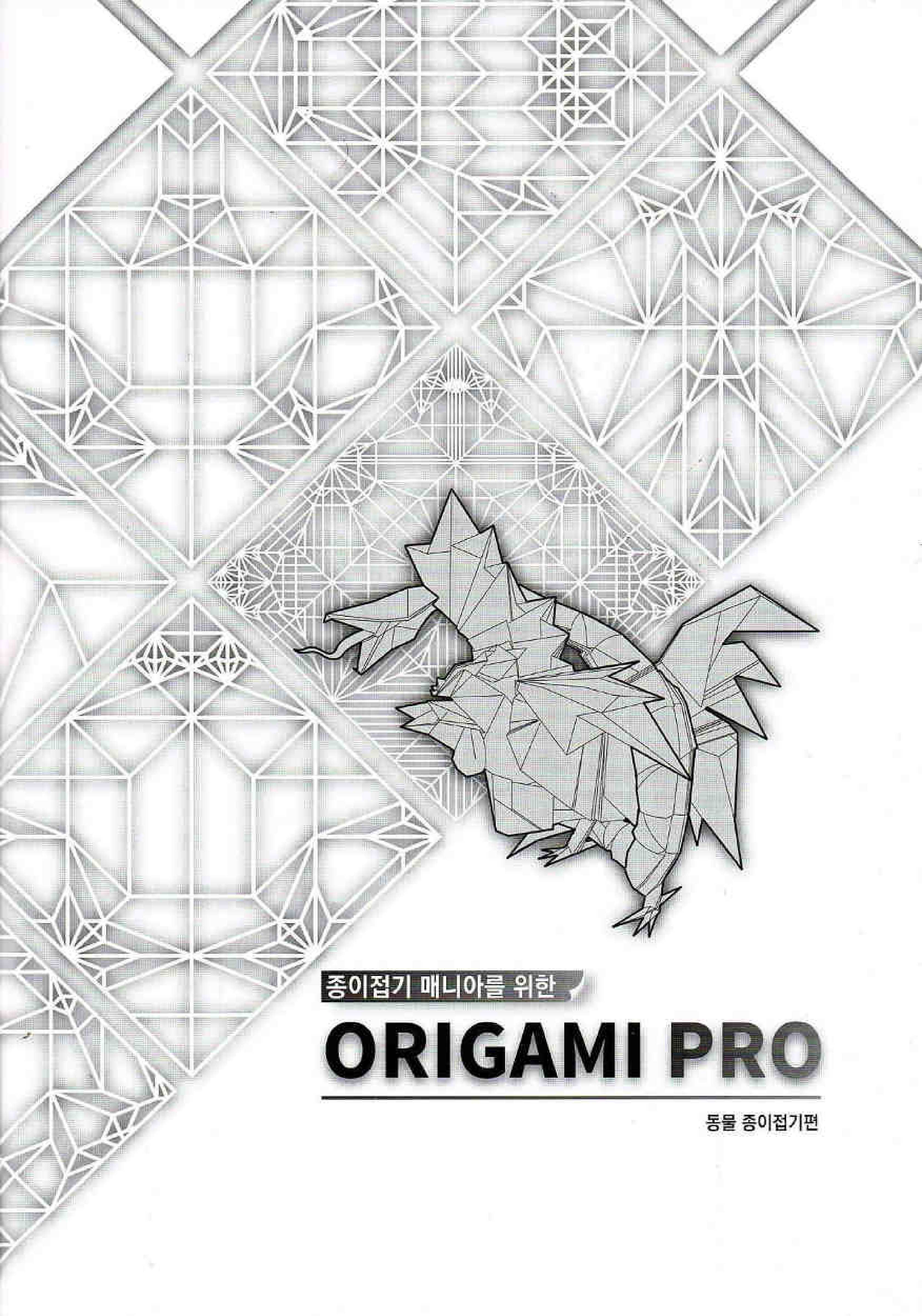

종이접기 매니아를 위한

ORIGAMI PRO

동물 종이접기편

CONTENTS

ORIGAMI PRO 를 출간하며	03p
작가소개	04p
접기 기본 기호 (Symbols of Folding)	06p
작품사진/전개도 (Picture / Crease Pattern)	07p
한국작품 (Korean-Models)	
양 (Sheep)	18p
돼지 (Pig)	24p
판다 (Panda)	29p
돌고래 (Dolphin)	36p
물개 (Fur Seal)	46p
멧돼지 (Wild Boar)	54p
먹이사슬 (Food Chain)	64p
해외작품 (Foreign - Models)	
도마뱀 (Lizard)	90p
말 (Horse)	95p

ORIGAMI PRO 를 출간하며



오경해

(사)한국종이접기협회 회장



김진우

기획 / 감수 / 편집

그 동안 종이접기 전문작가뿐만 아니라 모든 종이접기 애호가들이 소망 해 오던 국내작가들의 작품발표를 위한 ORIGAMI PRO의 발간을 기쁘게 생각합니다. 이미 일본을 비롯한 미국, 영국등 오랜 기간의 종이접기 역사를 지닌 나라에서는 전문작가들의 종이접기 서적 발간이 보편화되어 있는 현실에서 뒤늦은 감은 있지만 그만큼 빠른 성장으로 희망적인 미래를 예견할 수 있는 우리의 가능성을 생각하면 앞으로의 발전 가능성은 매우 크다고 생각됩니다. (사)한국종이접기협회는 26년전 설립되어 교육현장에서 종이접기를 체계적으로 보급해 오고 있으며 우리나라에서 종이접기가 발전 할 수 있는 토대를 만들고 전문작가 양성과 작가활동의 지원, 종이접기프로그램의 보급을 통해 누구나 즐길 수 있는 종이접기 문화를 만들어 가도록 최선의 노력을 다하고 있습니다. 한 장의 종이로 만들어지는 경이로운 종이접기의 세계에 많은 관심 가져주시고 한국의 종이접기 작가들에게 많은 격려와 후원을 부탁드립니다.

전세계적으로 볼 때 대한민국은 종이접기 문화가 아주 오래전부터 발전되어 왔지만, 교육을 위한 종이접기가 대부분이었습니다. 복잡한 종이접기, 예술적인 종이접기 작품이 국내에 알려지기 시작한 건 불과 10여 년 전 정도입니다. 유명한 종이접기 작가들과 작품들이 있는 미국과 일본에 비교해볼때 국내에도 많은 훌륭한 종이접기 작가와 매니아들이 있습니다. 올해 초 한국종이접기협회 회장님의 "우리나라에도 좋은 작가와 작품들이 있고, 매년 Korea Origami Convention 이 개최되는데 뜻깊은 책을 만들기 원한다" 라는 의견이 이렇게 ORIGAMI PRO라는 책으로 그 결실을 맺게 되었습니다. ORIGAMI PRO는 학생, 직장인으로 구성된 아마추어 작가들이 참여를 하였지만, 그들의 종이접기에 대한 열정과 실력은 해외의 작가들과 비교해도 손색이 없을 정도로 프로메셔널한 감각과 센스를 가지고 있습니다. 오늘날까지 국내에는 종이접기 매니아를 위한 예술적이고 어려운 작품들이 수록된 책은 거의 없었으므로, 이 책을 통해서 많은 종이접기 애호가들이 종이접기를 즐길 수 있는 계기가 되길 바랍니다. ORIGAMI PRO에 참여한 작가들은 한국종이접기협회에서 "매니아를 위한 종이접기 교실" 을 4년전부터 진행해 오고 있으며, 비록 아마추어 작가들이지만 국내의 종이접기 저변 확대에 많은 노력을 하고 있습니다. 앞으로 ORIGAMI PRO 2권, 3권이 출간되길 바라며, 이 책이 출간되기까지 함께 한 한국종이접기협회 오경해 회장님과 이송윤 사무국장님, 이경구 부장님 그리고 장용익, 이인섭, 유태용 작가들, 모든 한국종이접기협회 관계자분들에게 감사드립니다. 아울러 해외작가 Nguyen Hung Cuong 과 Roman Diaz 와 출간의 기쁨을 함께하고 싶습니다.

작가소개

About the Origamist

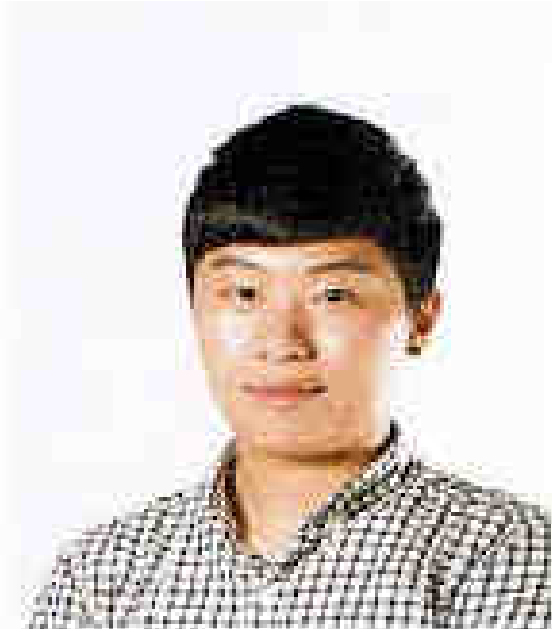

장용익 | Jang Yong Ik

1991 | 한국

<http://blog.naver.com/gkfao7>



유태용 | Yoo Tae Yong

1996 | 한국

<http://blog.naver.com/qpemfh95>



이인섭 | Lee In Seop

1992 | 한국

<http://blog.naver.com/inseop999>

누구나 어렸을 적 한번은 접어 보았을 종이접기가 과연 어디까지 발전하고 응용될지 궁금하지 않으신가요? 저는 그 수많은 방향 중 종이접기와 디자인이 만나게 되었을 때 가장 이상적인 종이접기가 되리라 생각하고 있습니다. 지금 보고 계시는 이 책 또한 엄연히 종이접기와 디자인의 결과물이죠. 저는 저만의 방법으로 이상적인 종이접기를 하기 위해 현재 대학교에서 시각디자인을 전공중인 동시에 종이접기 창작가의 활동을 하고 있습니다. 저는 주제에 제한을 두지 않고 넓은 스펙트럼의 모델을 종이접기로 창작하고 있습니다. 하나의 작품을 완성하기까지 적게는 3시간 정도에서 길게는 몇 달이 걸리기도 합니다. 중요하게 작업하는 부분은 작품을 보는 이가 인상적으로 느낄 수 있도록 하는 부분입니다. 그러기 위해서 작품의 디자인에 많은 시간을 할애하고 있습니다.

현재 일본에서 유학생생활을 하고있습니다. 제가 추구하는 종이접기는 특징이 잘 접힌 종이 접기입니다. 개인적으로 실물과 흡사하게 접는 작품보다 특징만 잘 잡힌 작품을 선호합니다. 나아가 특징을 어떻게 표현하는지에 따라, 작가의 개성이 표현된다고 생각합니다. 앞으로의 계획이 있다면 종이접기를 조금이라도 대중화하는 것입니다. 종이접기가 단순히 유치하고 생각되는 놀이가 아닌, 예술활동의 하나로서 인정받고 활용할 수 있는 분야를 찾고 싶습니다.

접기선의 아름다움과 종이의 무한한 표현력에 매료되어 6살 때부터 지금까지 종이접기를 하고 있습니다. 저는 작품 구조의 아름다움을 중히 여기기 때문에 선과 각의 수학적 관계가 잘 어울리게 설계하도록 노력하고 있습니다. 현재는 22.5도 각도의 조형성에 관심이 많아 작품이 다소 복잡한 편입니다. 작품의 주제는 종이접기로 한번도 나온 적이 없는 독특한 주제에 관심이 많습니다.

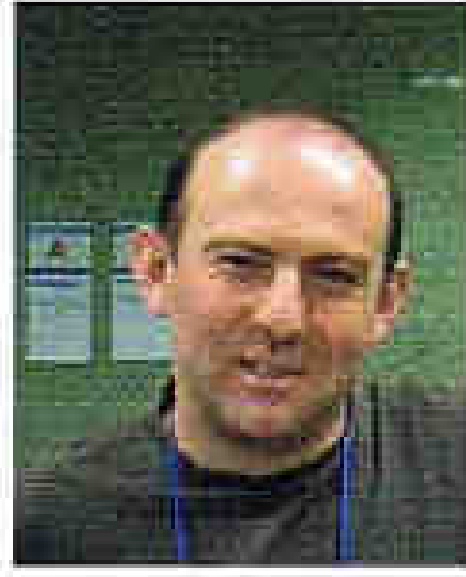

호만 디아즈 | Roman Diaz
1968 | 우루과이
<https://www.flickr.com/photos/88586913@N00>



응웬 흥 쩡 | Nguyen Hung Cuong
1989 | 베트남
<https://www.flickr.com/photos/blackscorpion>



김진우 | Kim Jin Woo
1979 | 한국
<http://blog.naver.com/5669hsig>



김영민 | Kim Young Min
1978 | 한국
<http://blog.naver.com/miniy2000>

어린시절 많은 여행을 하면서 때때로 종이접기에 대한 연구를 하였습니다. 성인이 된 후에는 우루과이로 되돌아가 저의 연구를 완료한 후 수의사가 되었습니다. 이후 오리가미의 가능성에 매료된 저는 종이접기 작품을 디자인하기 시작했고, 2006년부터 시작한 동물에 대한 디자인은 국제적으로 주목을 받고 있습니다. 그 이후로 스페인, 프랑스, 이탈리아, 독일, 칠레, 한국 오리가미 컨벤션의 특별게스트로 참가하였으며 2권의 책을 출판하였습니다.

현재 하노이 기술대학교 학생입니다. 저는 7살부터 종이접기를 시작해서 10살 때 첫 창작품을 만들었습니다. 베트남 종이접기 그룹에는 2005년에 가입했고, 2009년 제 15회 일본 JOAS 컨벤션에 초청받아 스페셜 게스트로 참가했습니다. 저는 주로 컴플렉스 계열의 작품을 창작하고 동물 계열을 좋아하며 항상 자연 그대로의 형태를 제 작품에 표현하기 위해 노력하고 있습니다.

초등학교 3학년 무렵부터 종이접기를 시작하였습니다. 그 당시 동네의 친한 형에게 종이접기책 안의 어려운 작품들을 접어 달라고 많은 응석도 부렸습니다. 중학교에 입학한 뒤로는 대구 지역의 서점들을 돌아다니며 많은 종이접기 책들을 수집하곤 했습니다. 하지만 학업과 군복무의 시간을 보내며 잠시 종이접기를 하지 못했습니다. 사회생활을 시작한 후에 경제적으로 여유가 생겨 다양한 종이접기 행사에 참가하면서 많은 종이접기 애호가들을 만날 수 있었습니다. 현재는 Crease Pattern 관련 수업을 한국종이접기협회에서 4년 전부터 진행하는 동시에 한국의 종이접기 애호가들에게 세계의 멋진 작품들과 Crease Pattern들을 소개하기 위해 힘을 쏟고 있습니다.

제 전공은 전기 전자로 현재 소규모 컴퓨터관련 자영업에 종사하고 있습니다. 종이접기를 처음 시작한 지는 30년전 초등학교 5학년 때였습니다. 평소 그림 그리기를 좋아하고 만들기도 재능이 있어 담임선생님께서 방과 후에 그림을 지도해 주시면서 종이접기도 가르쳐 주셨습니다. 현재 다른 작가들의 Crease Pattern 또는 도면 (Diagram)을 그리는 일을 지원하고 있으며 비록 일본어 전공은 아니지만, 직장에 있을 때 매뉴얼을 번역한 경험을 바탕으로 틈틈이 일본 오리가미 관련 기사 자료를 번역하는 일을 하고 있습니다. 비록 다른 작가의 작품들을 접거나 도면을 그림니다만, 직접 창작을 해 보고 싶은 마음이 있습니다.

접기 기본 기호

Symbols of Folding

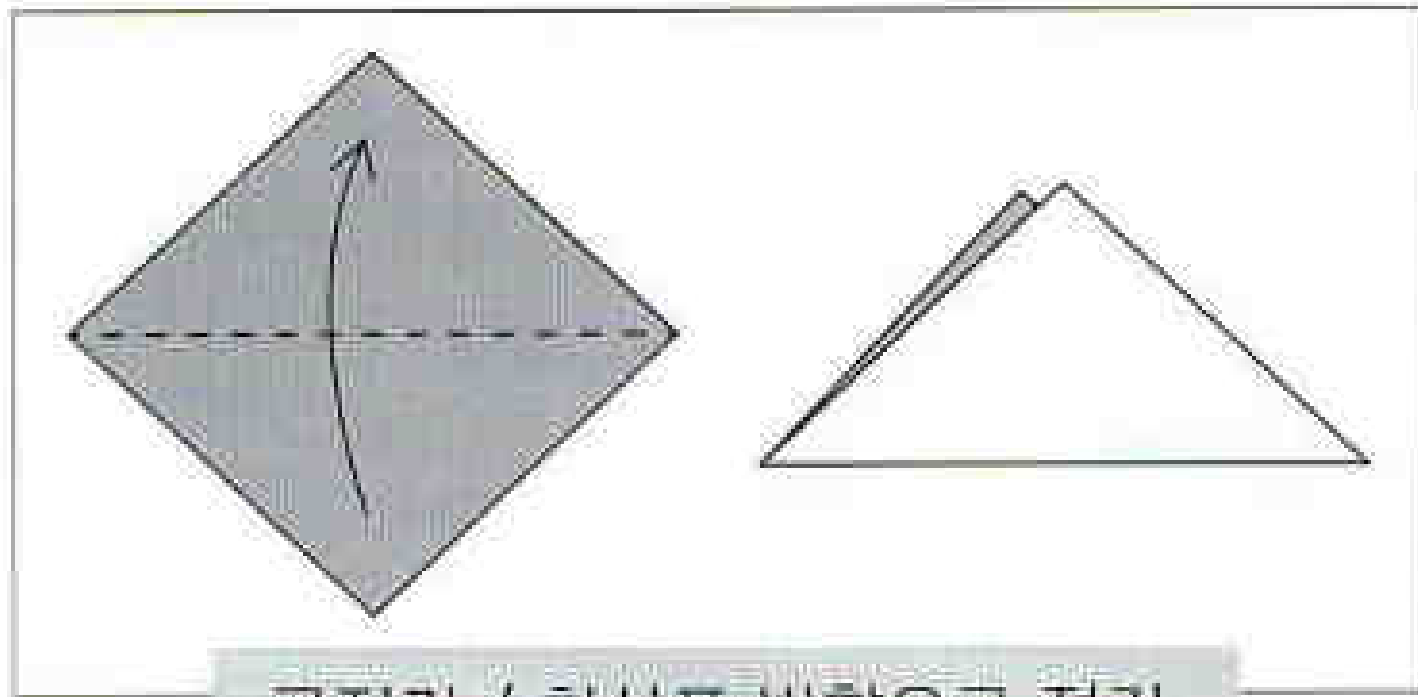

골접기 / 화살표 방향으로 접기

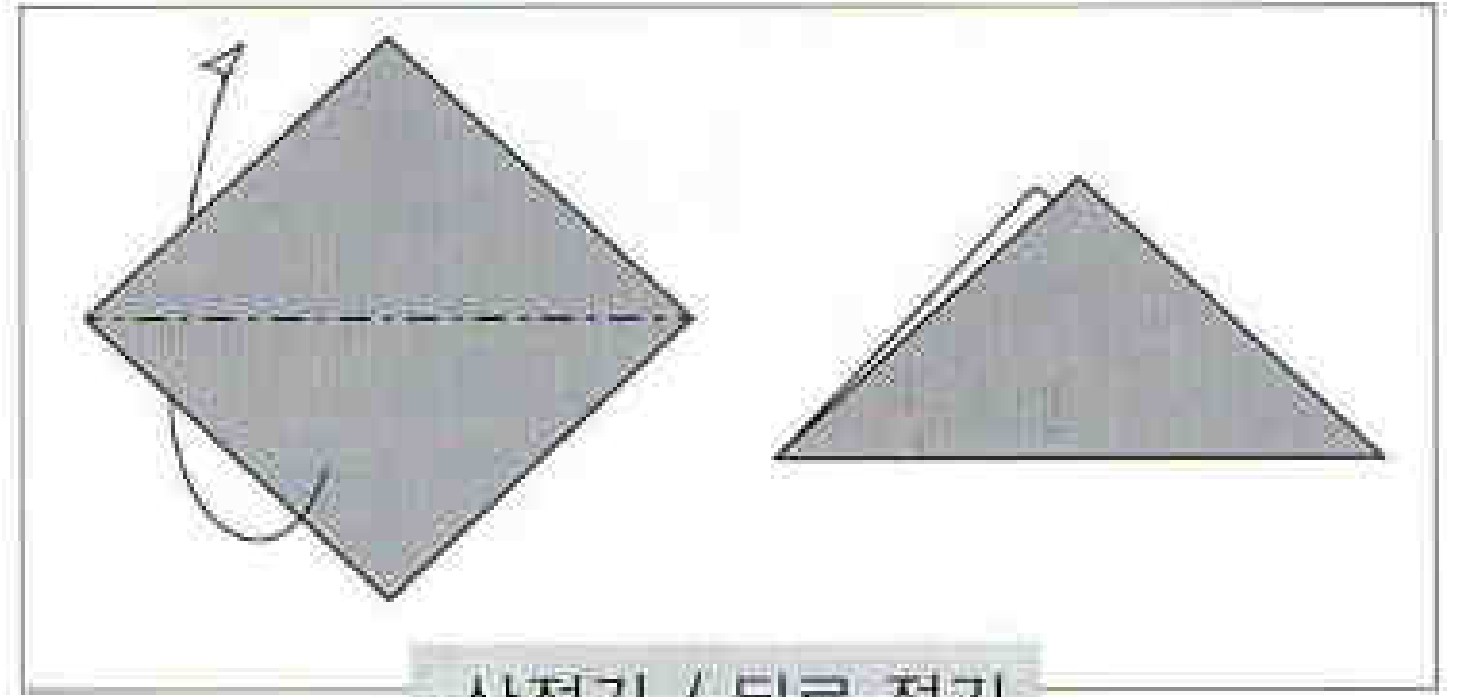

산접기 / 뒤로 접기

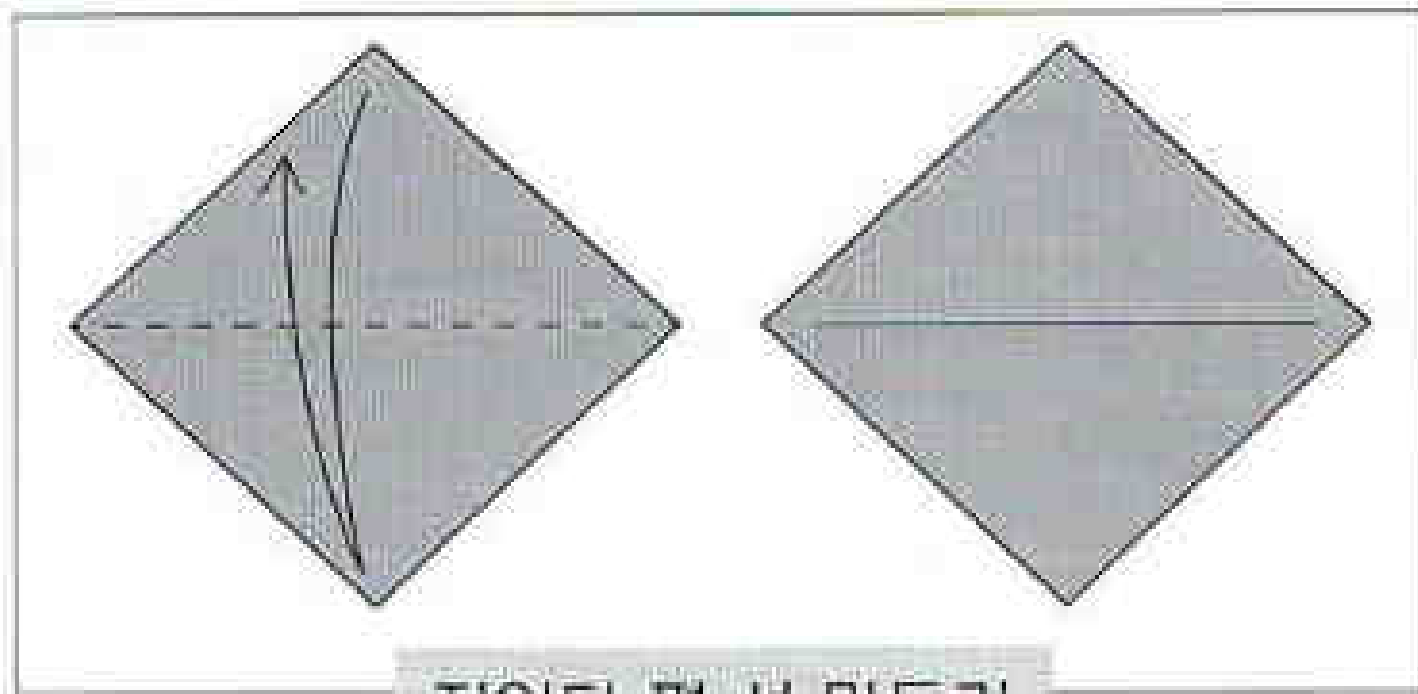

접었다 편 선 만들기

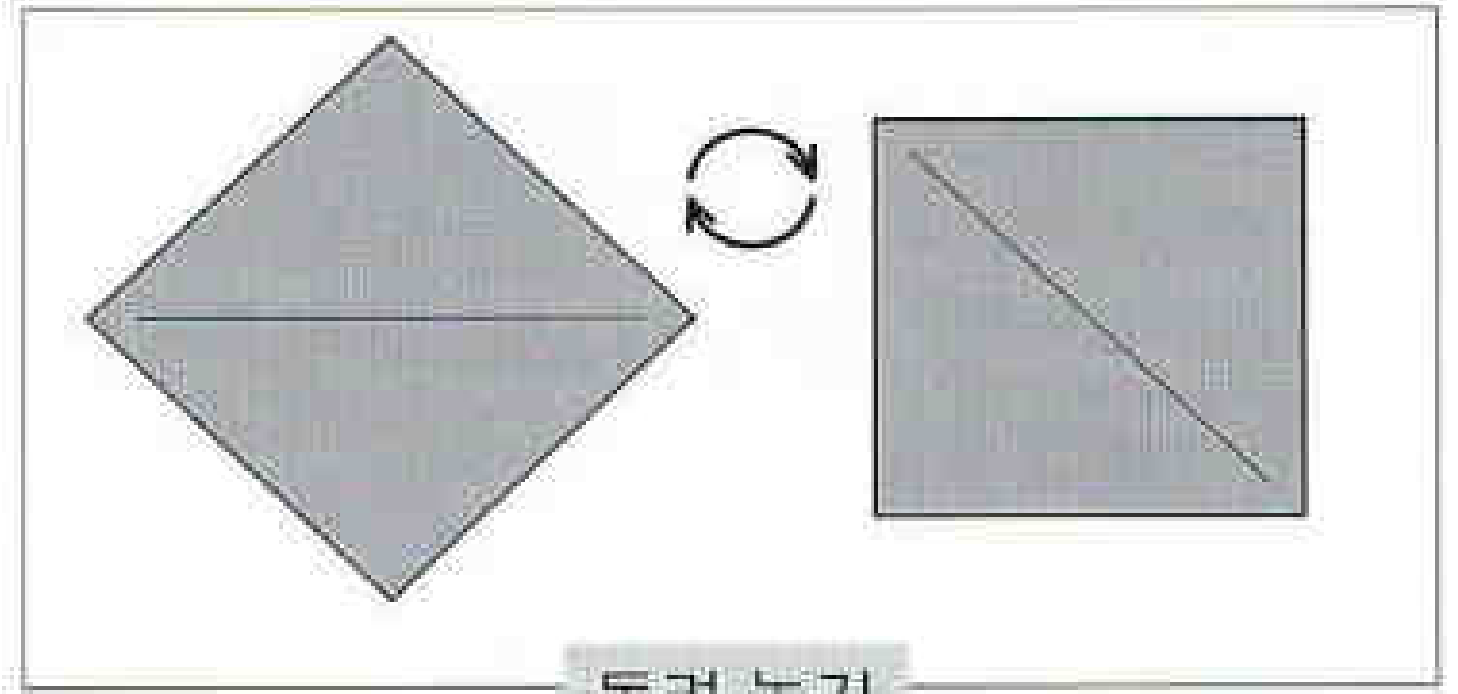

돌려 놓기

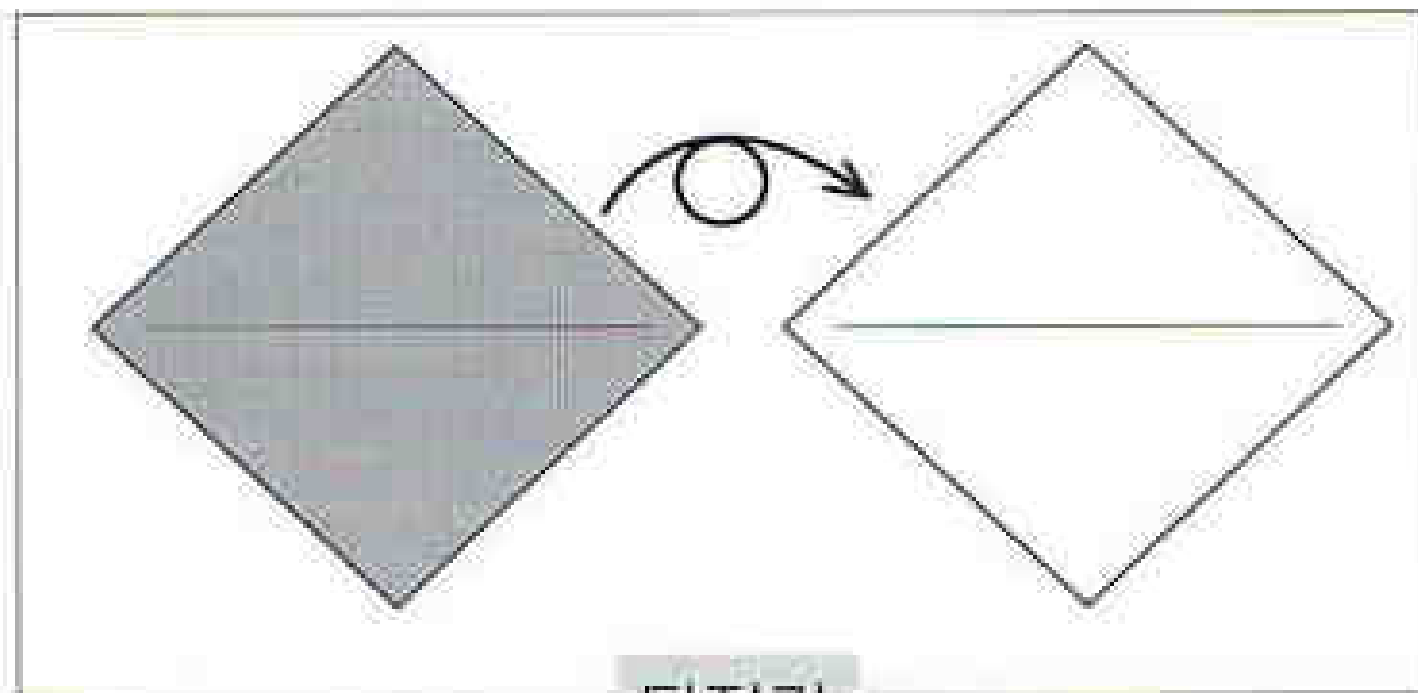

뒤집기

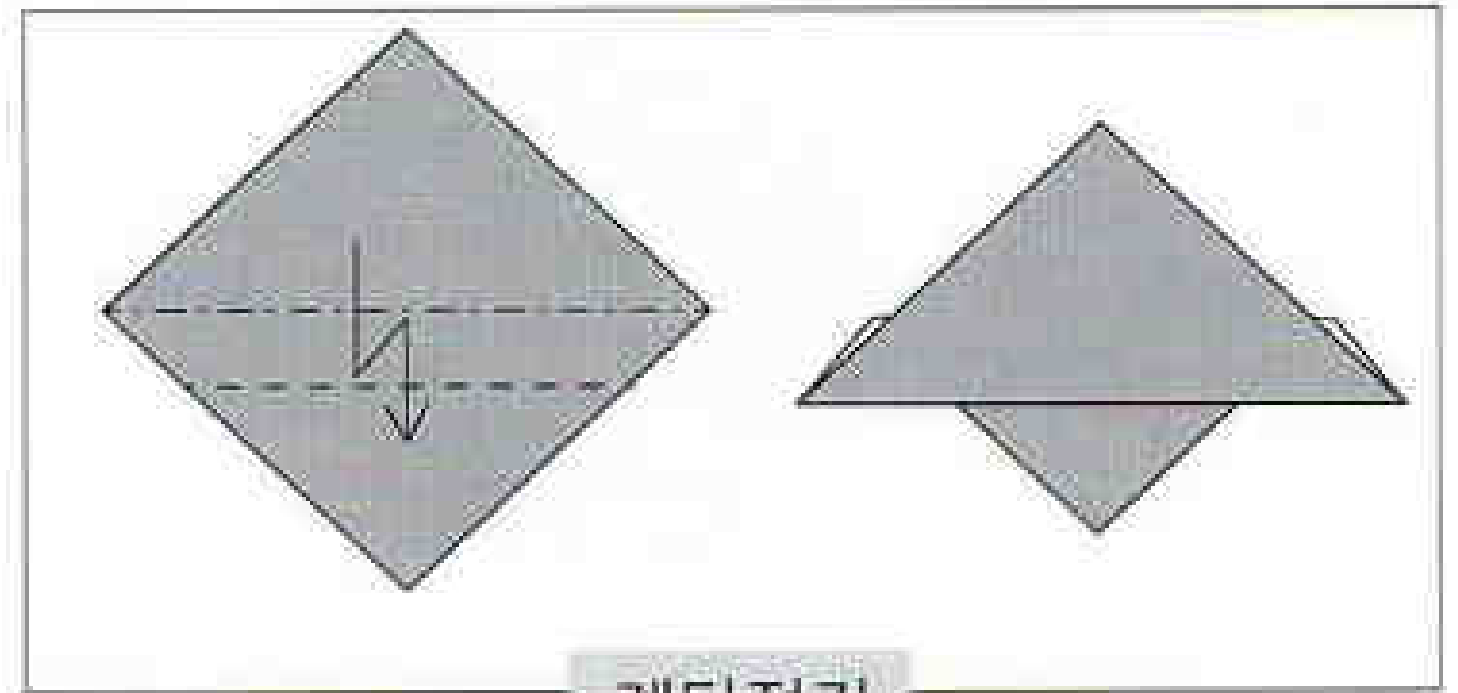

계단접기

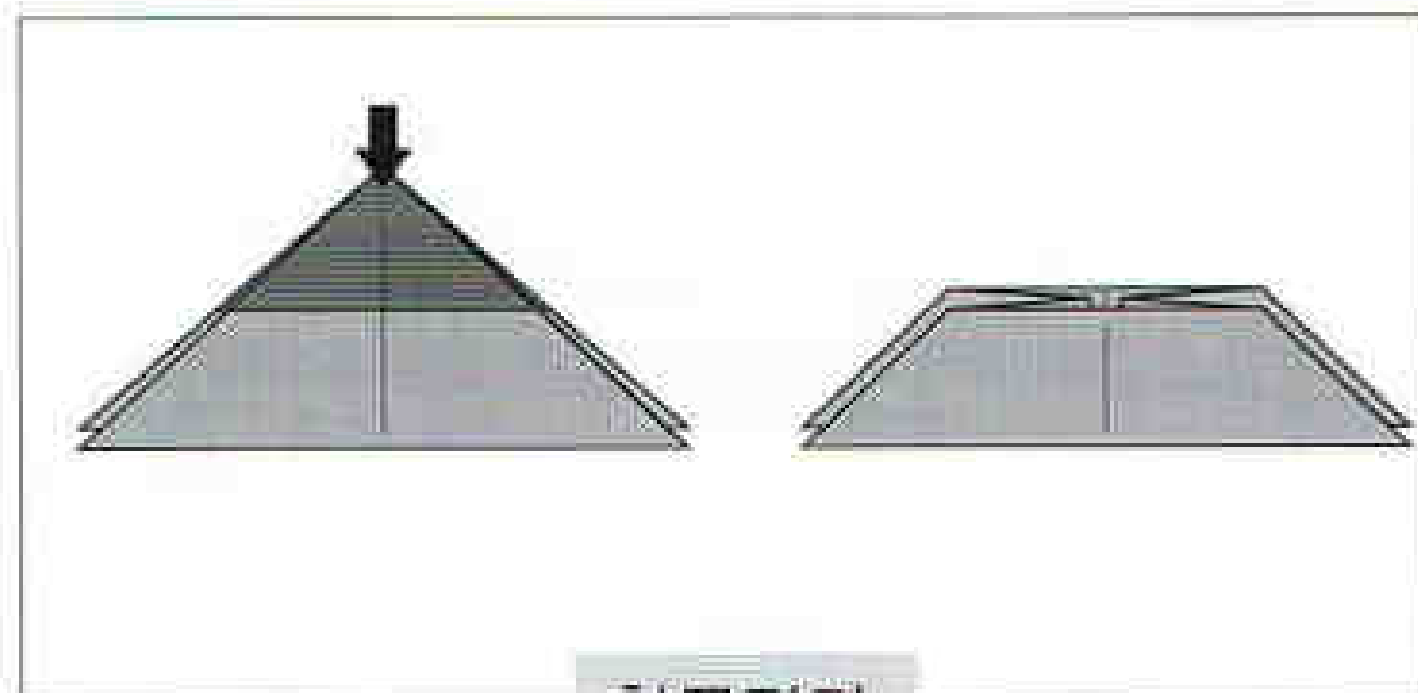

함몰접기

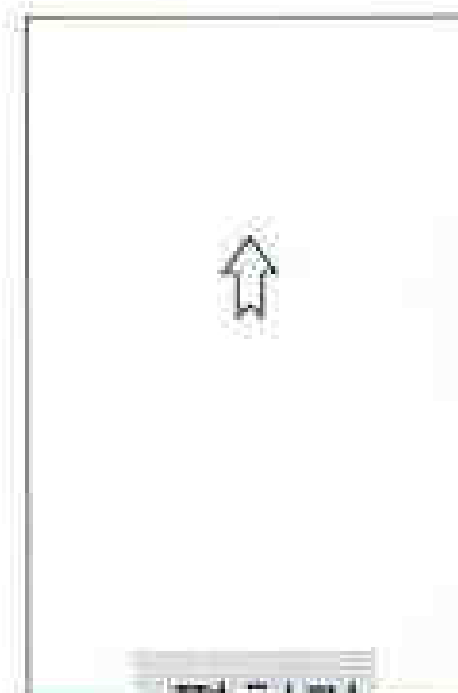

펼치기

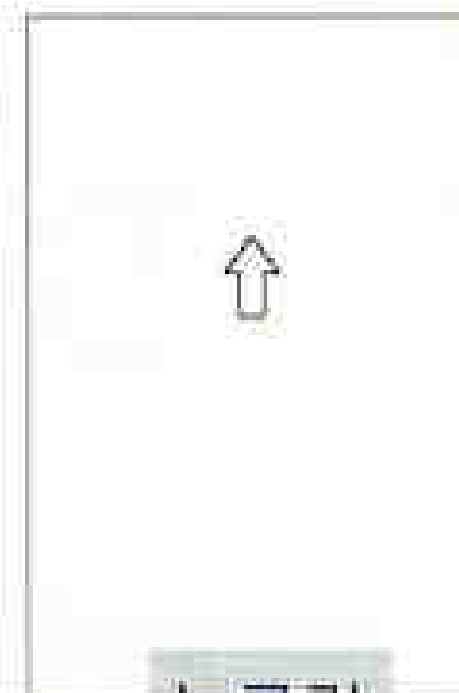

누르기

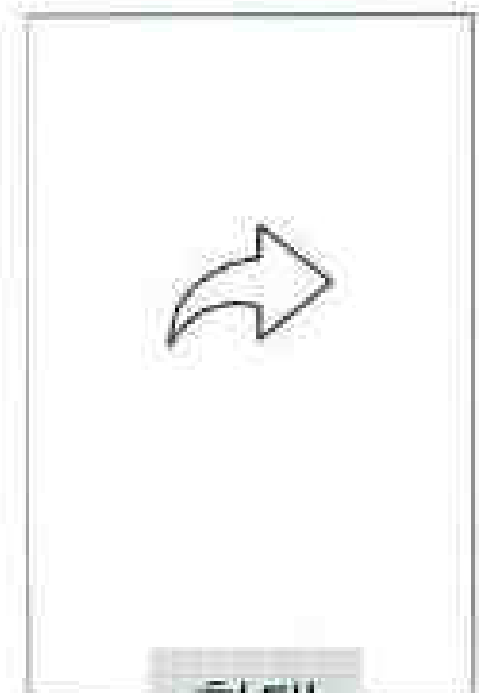

확대

작품사진 / 전개도

Picture / Crease Pattern

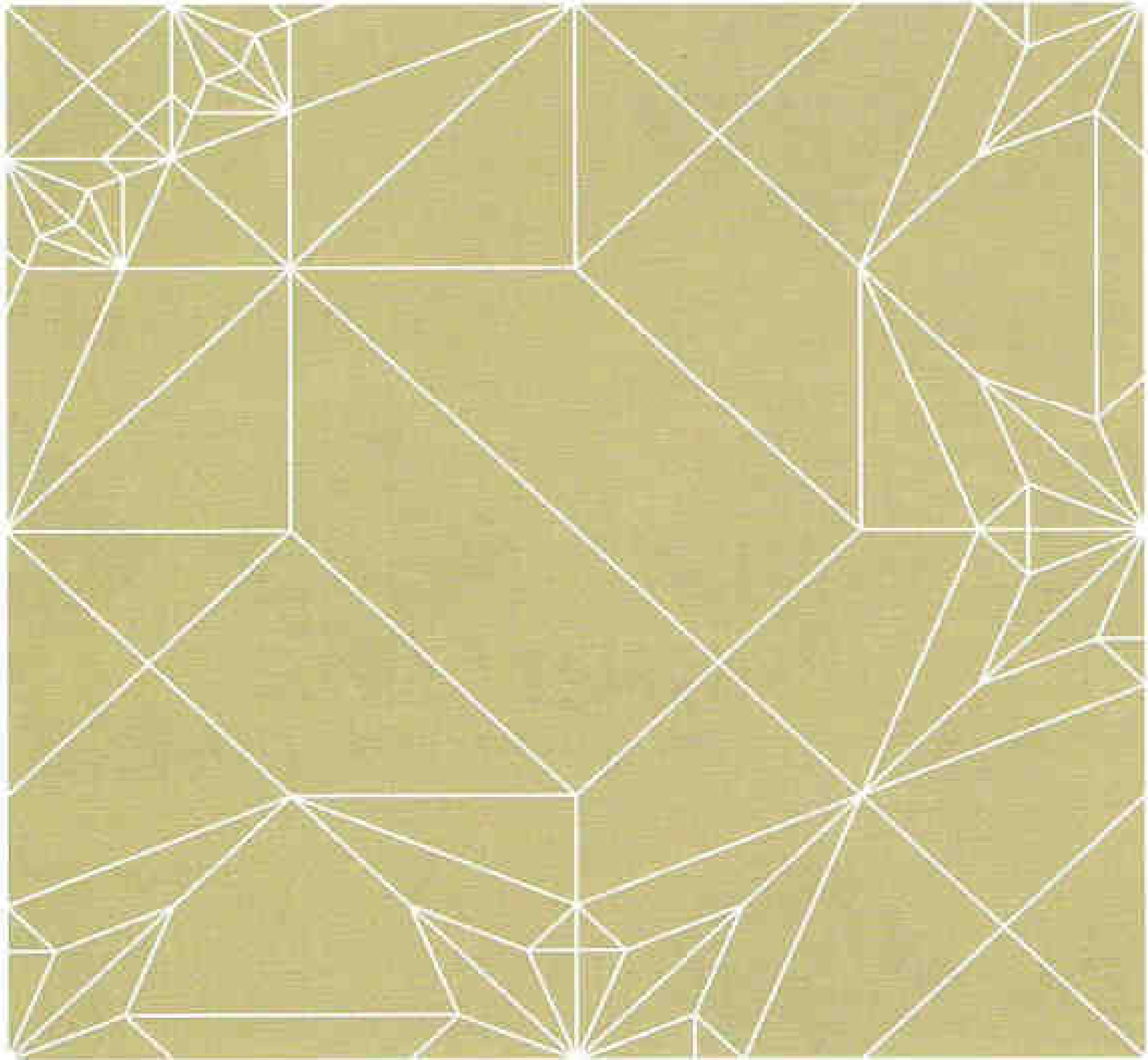

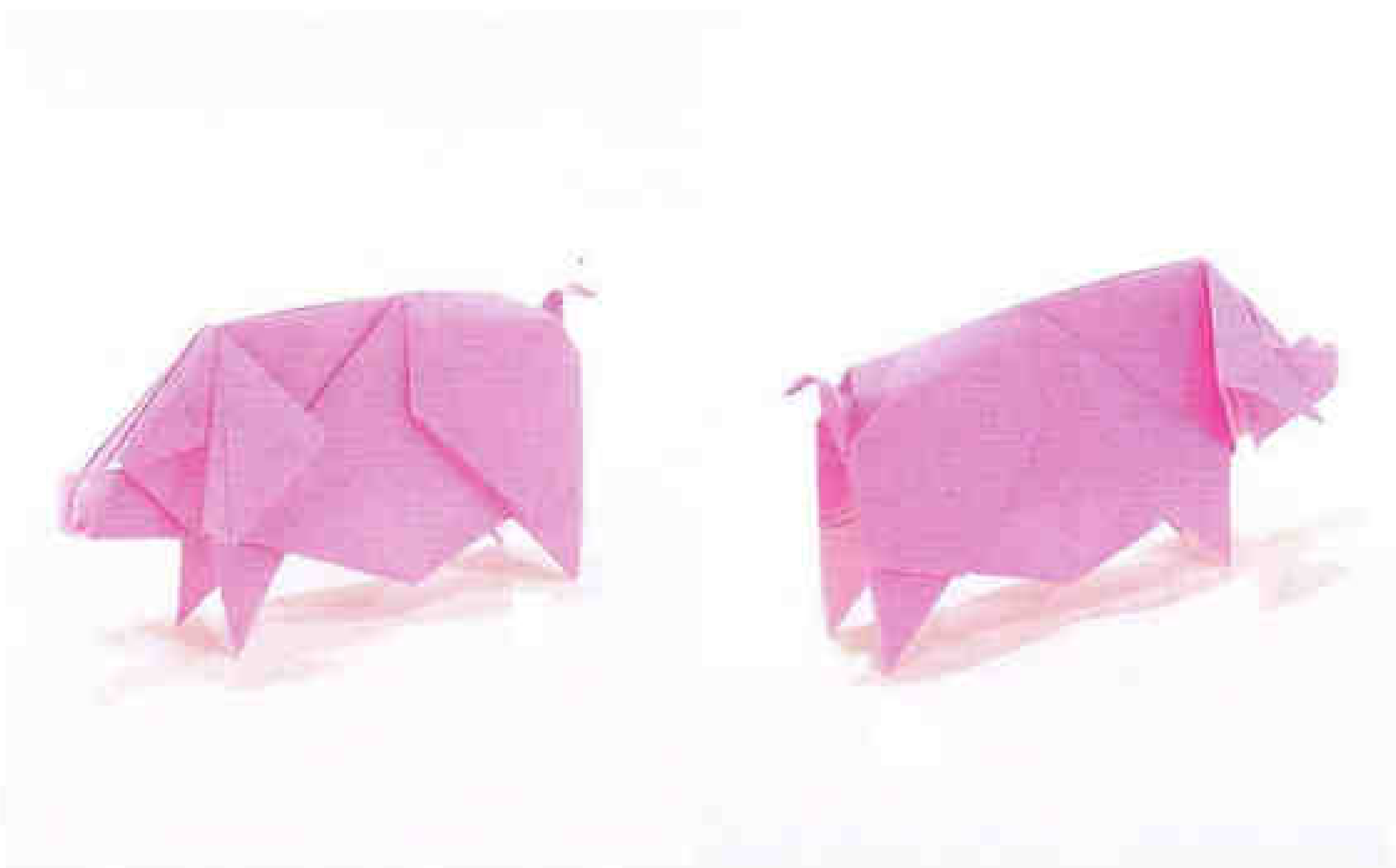
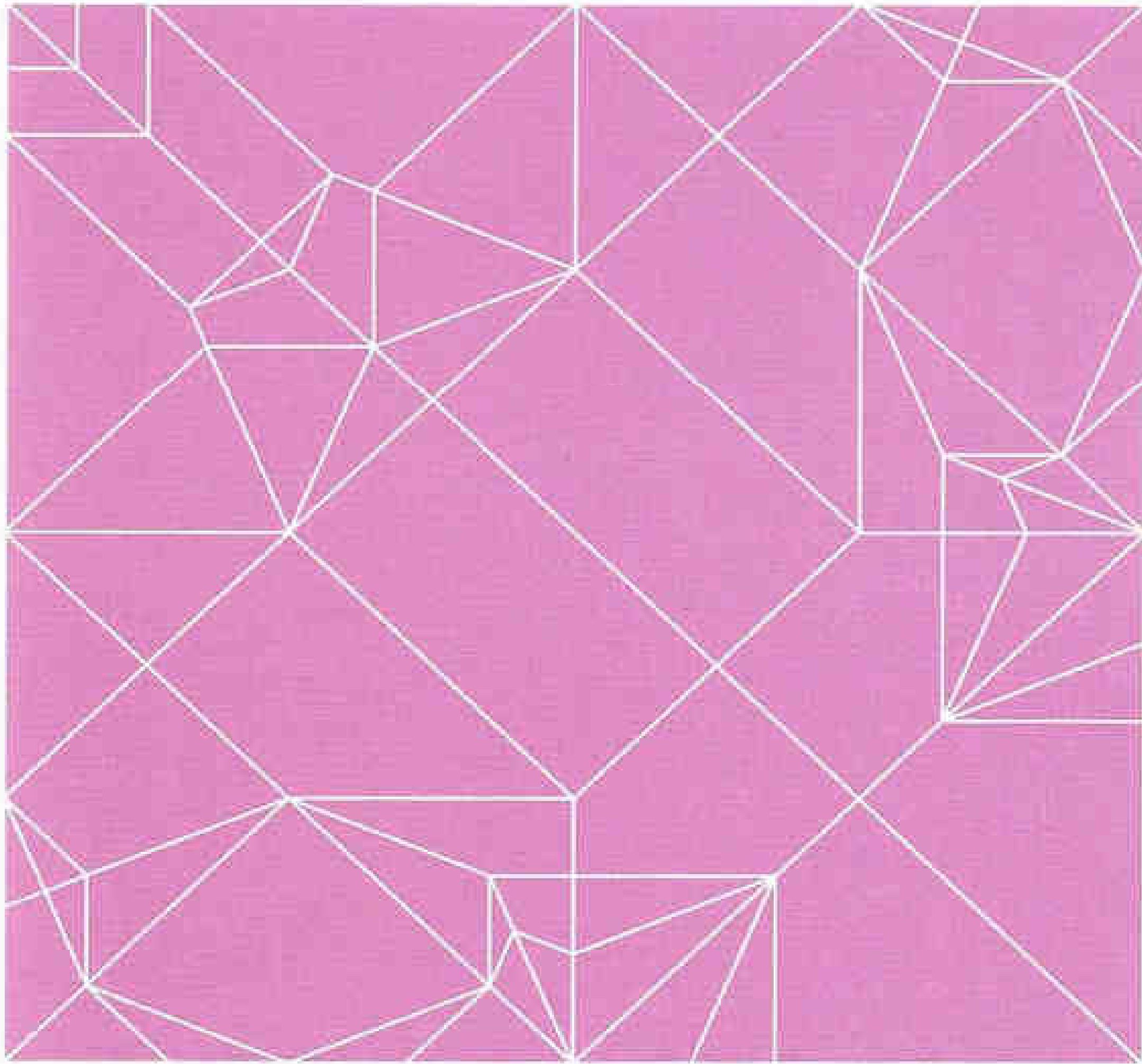

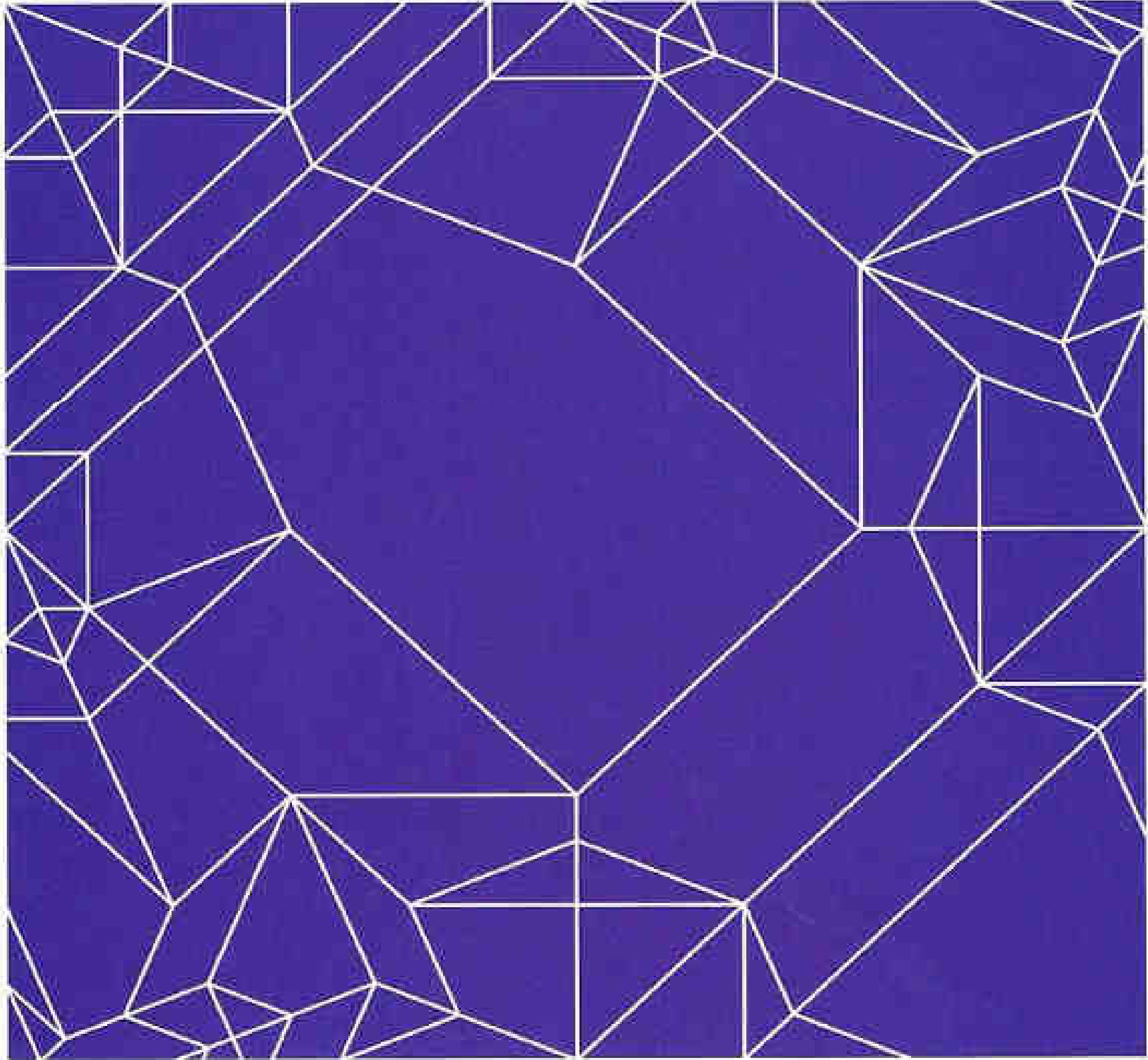

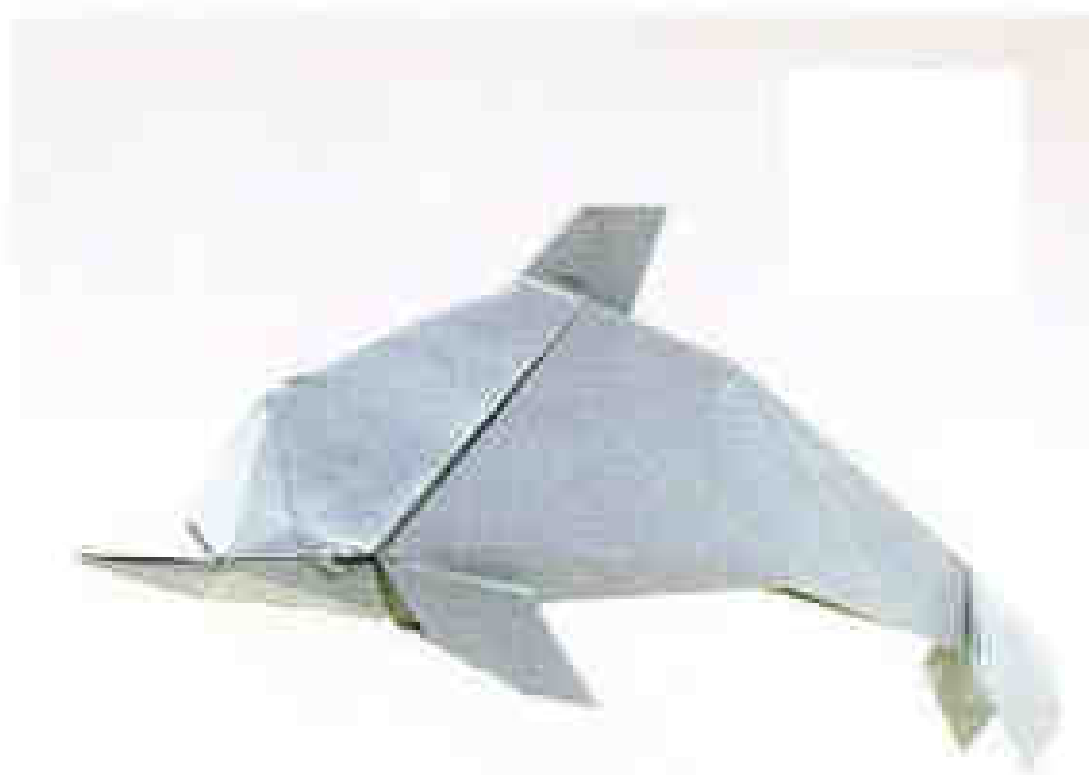
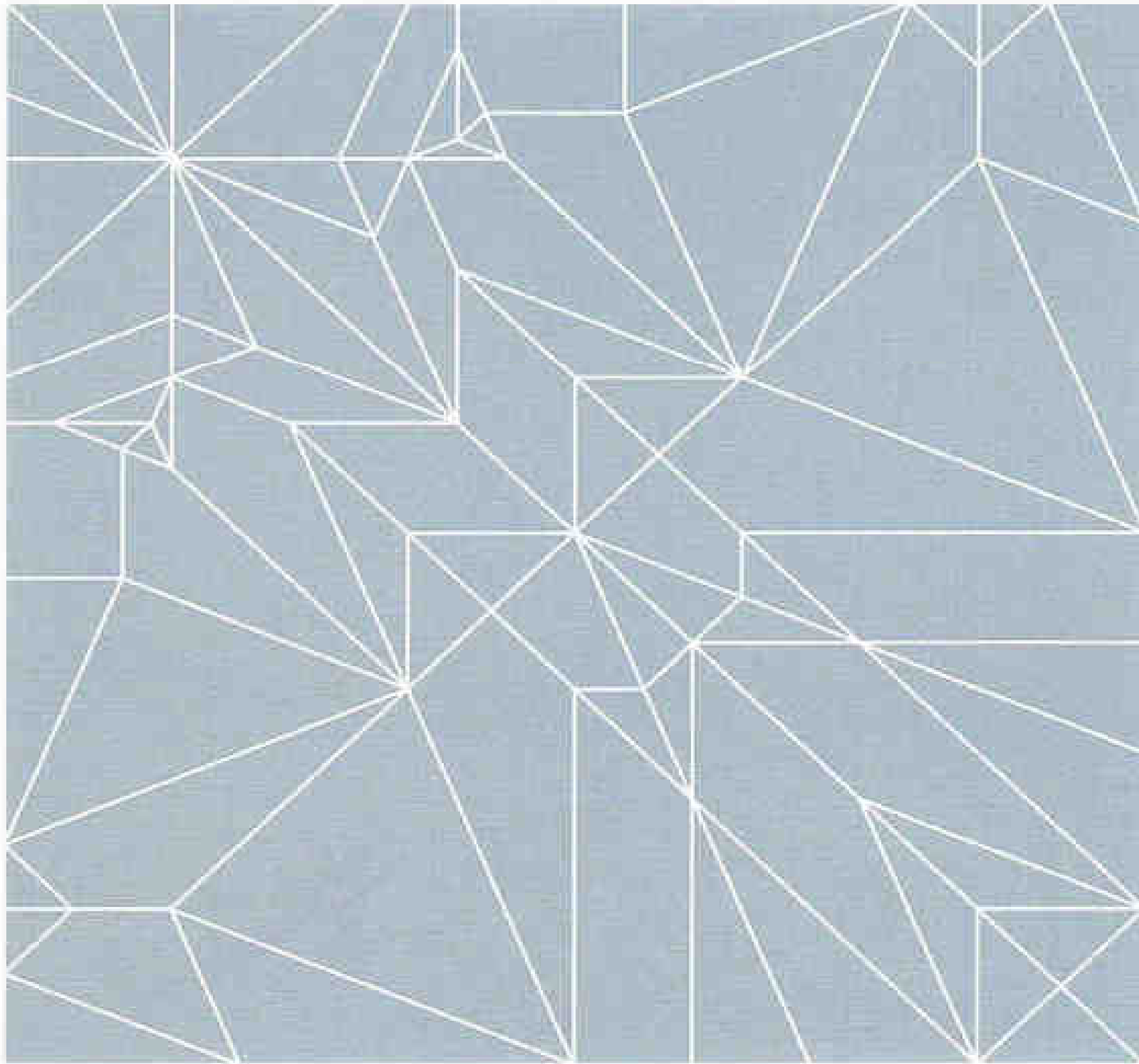

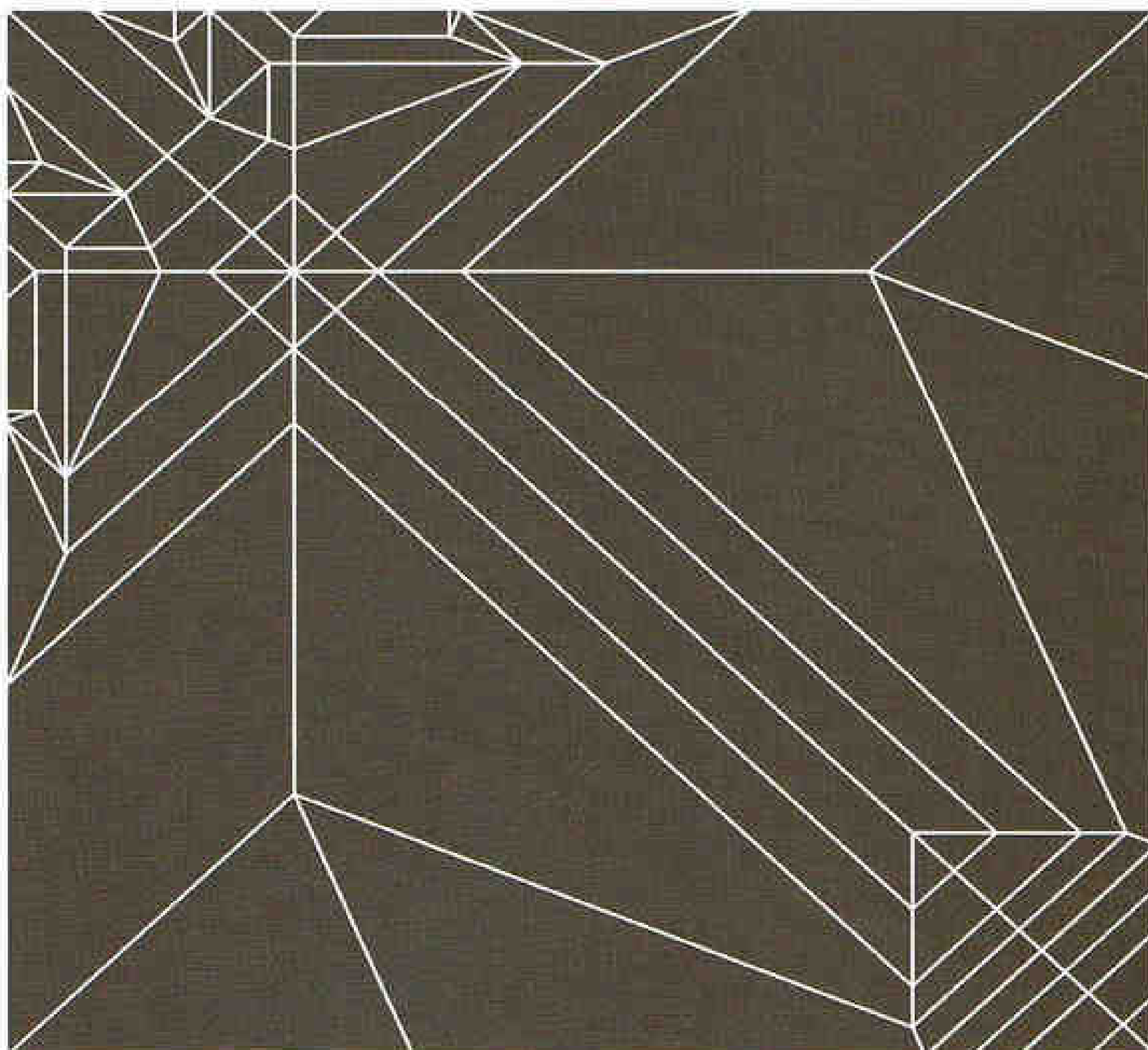

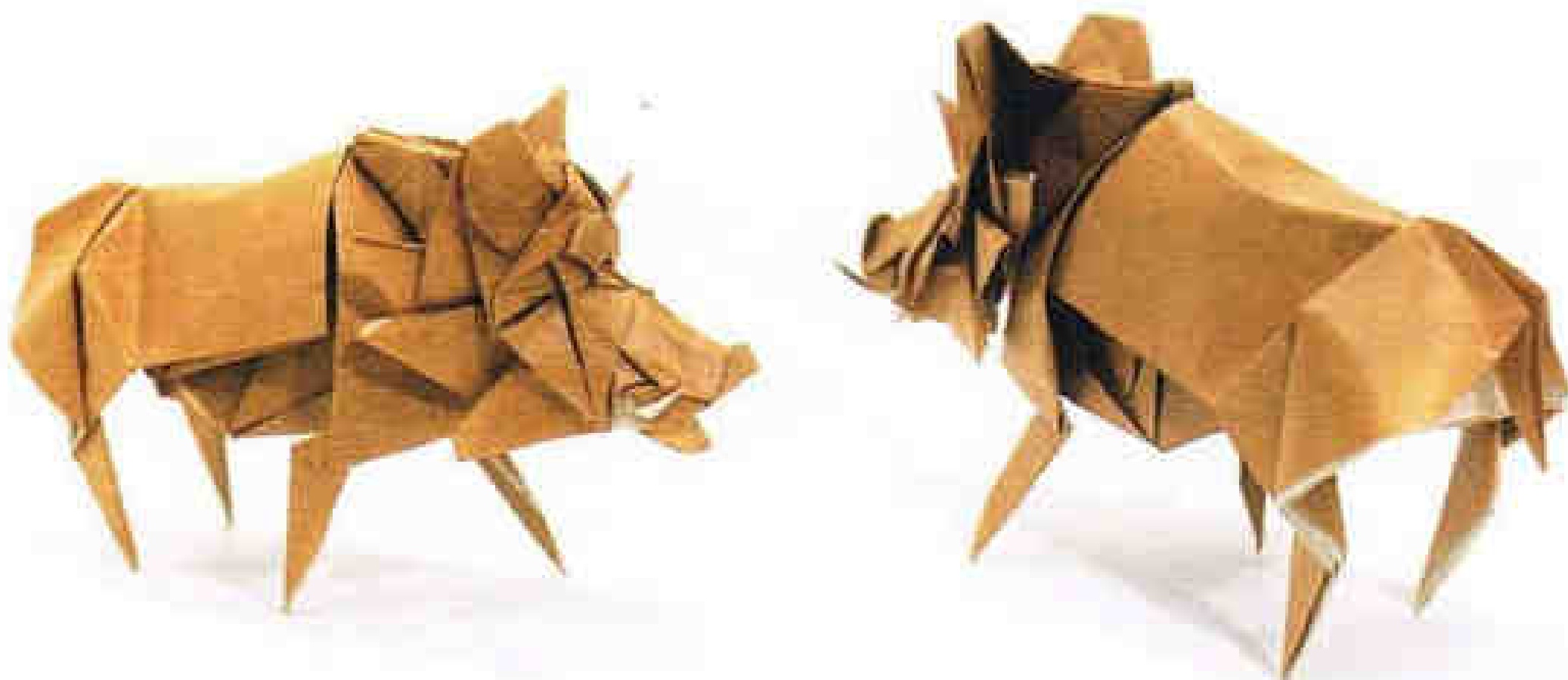
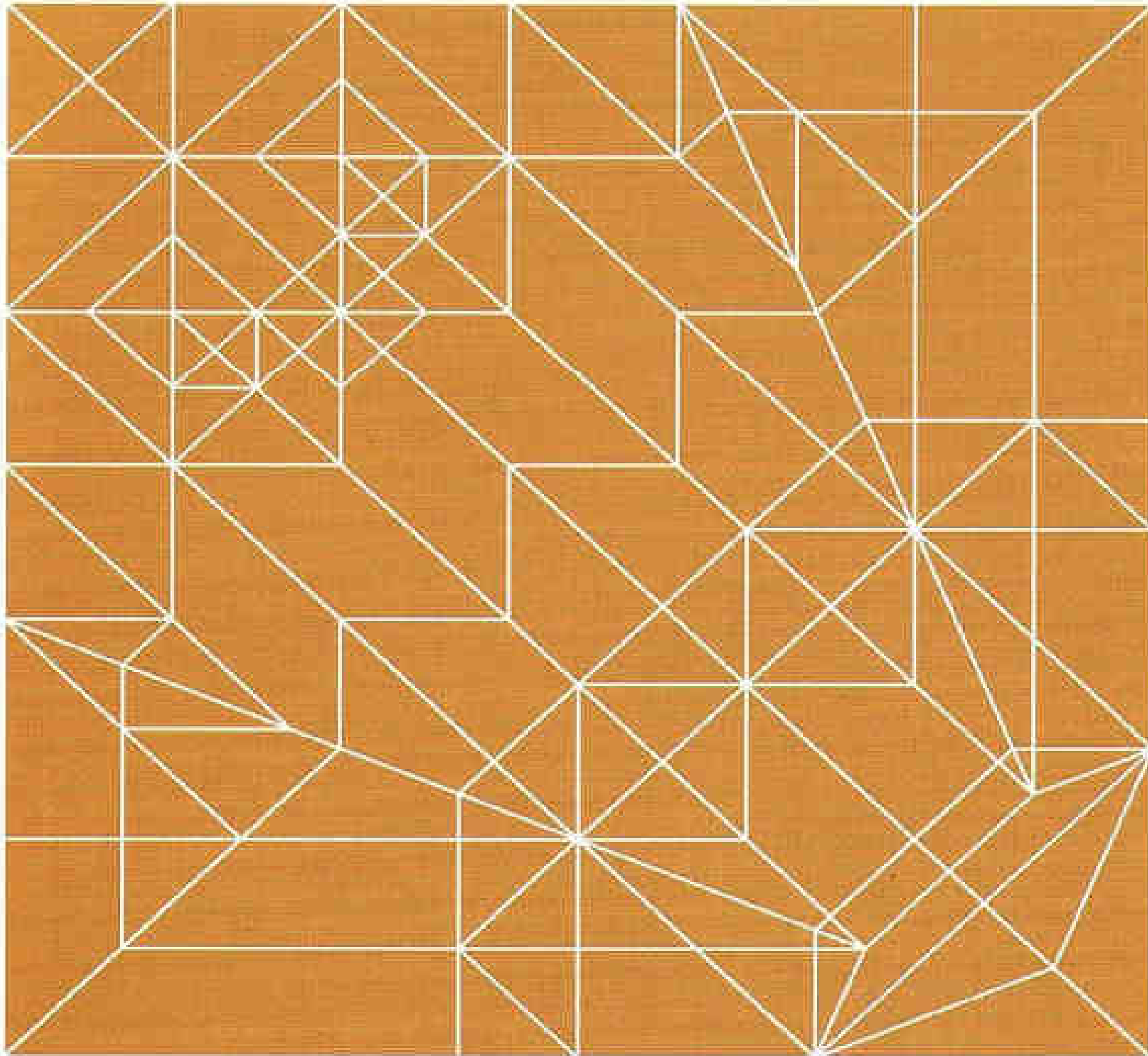

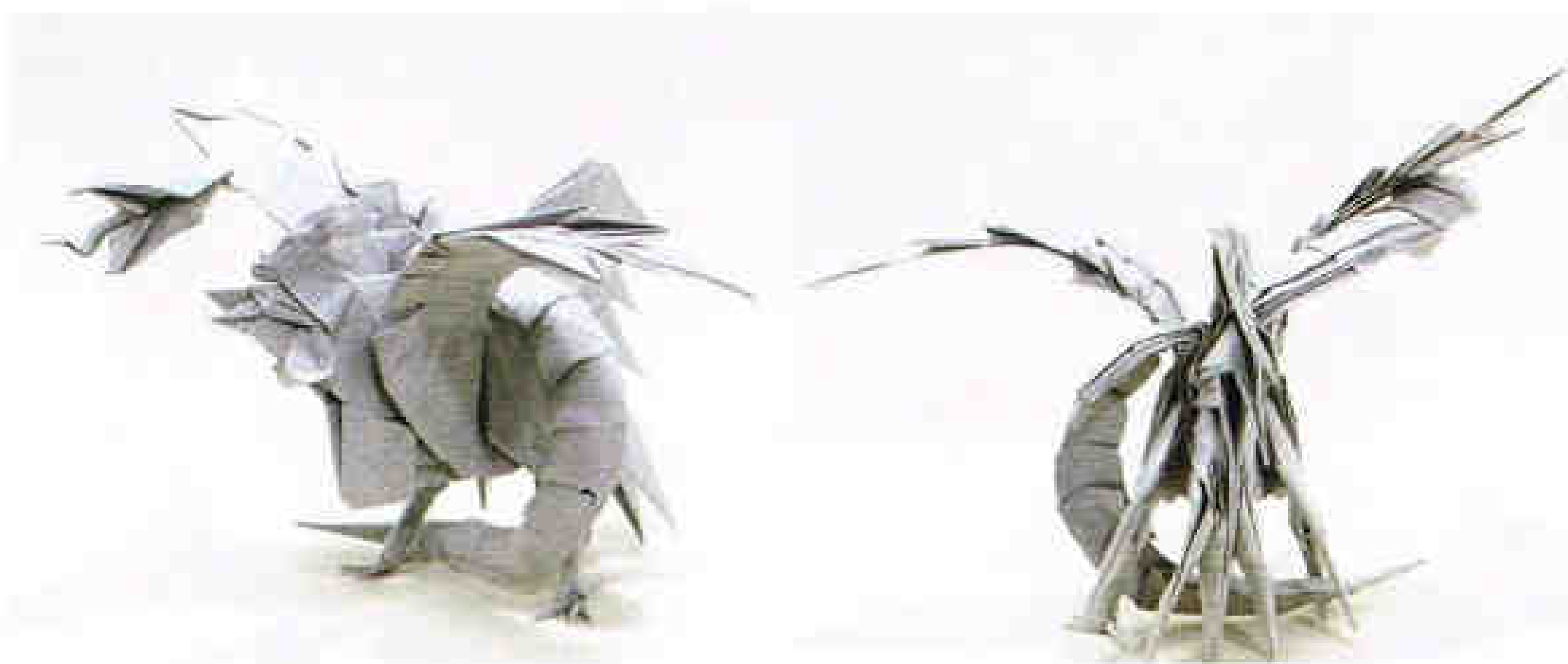
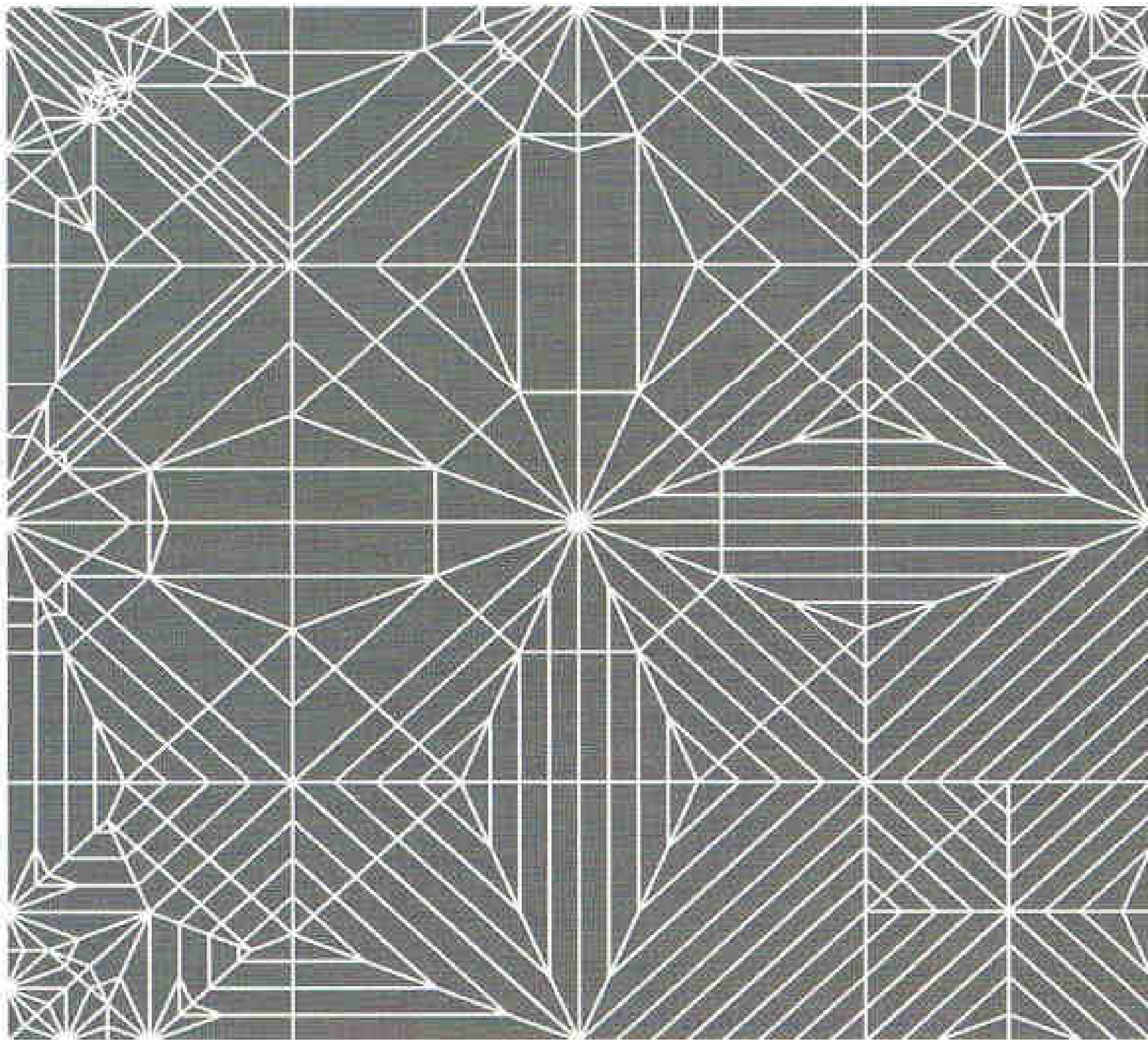

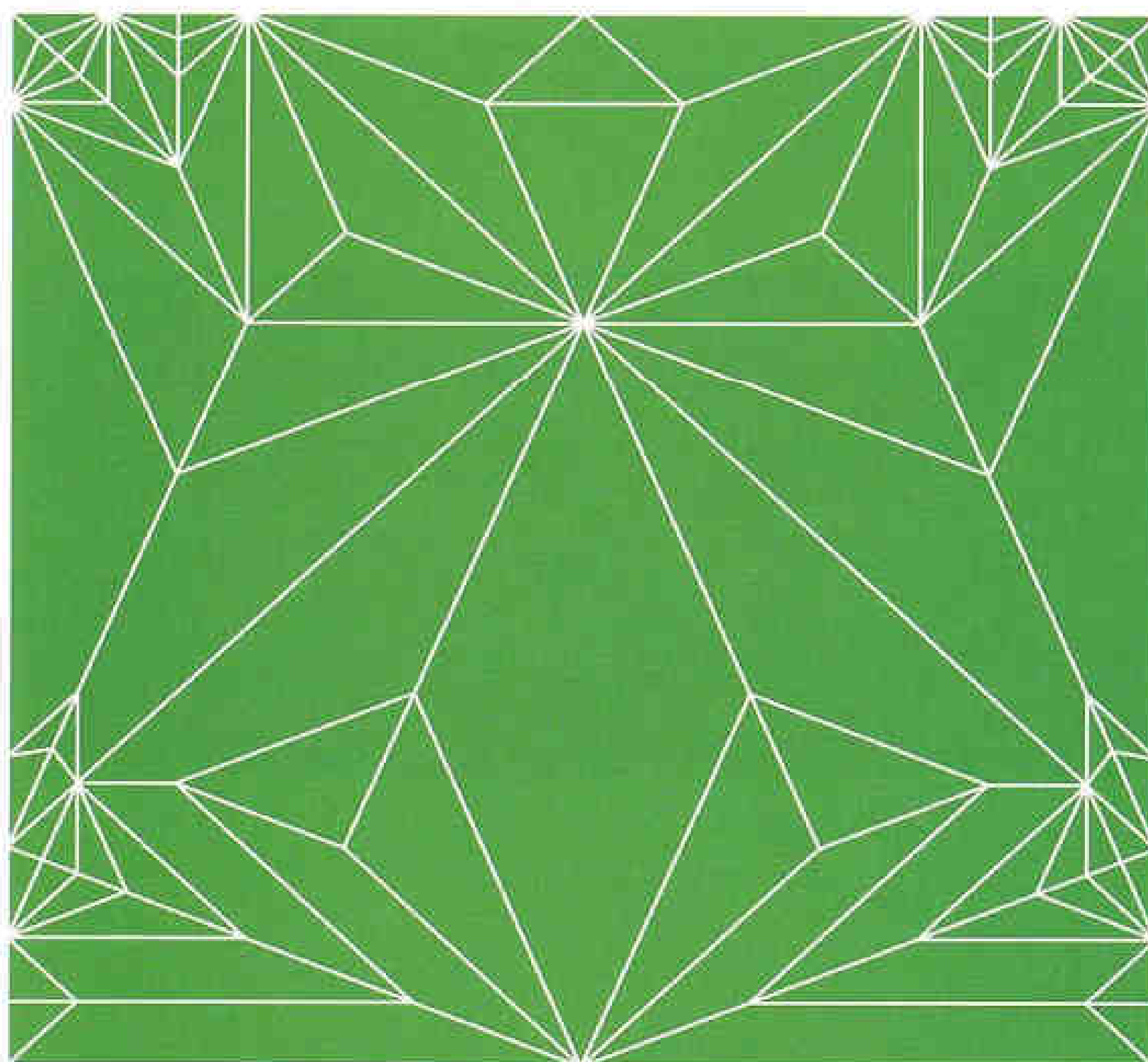

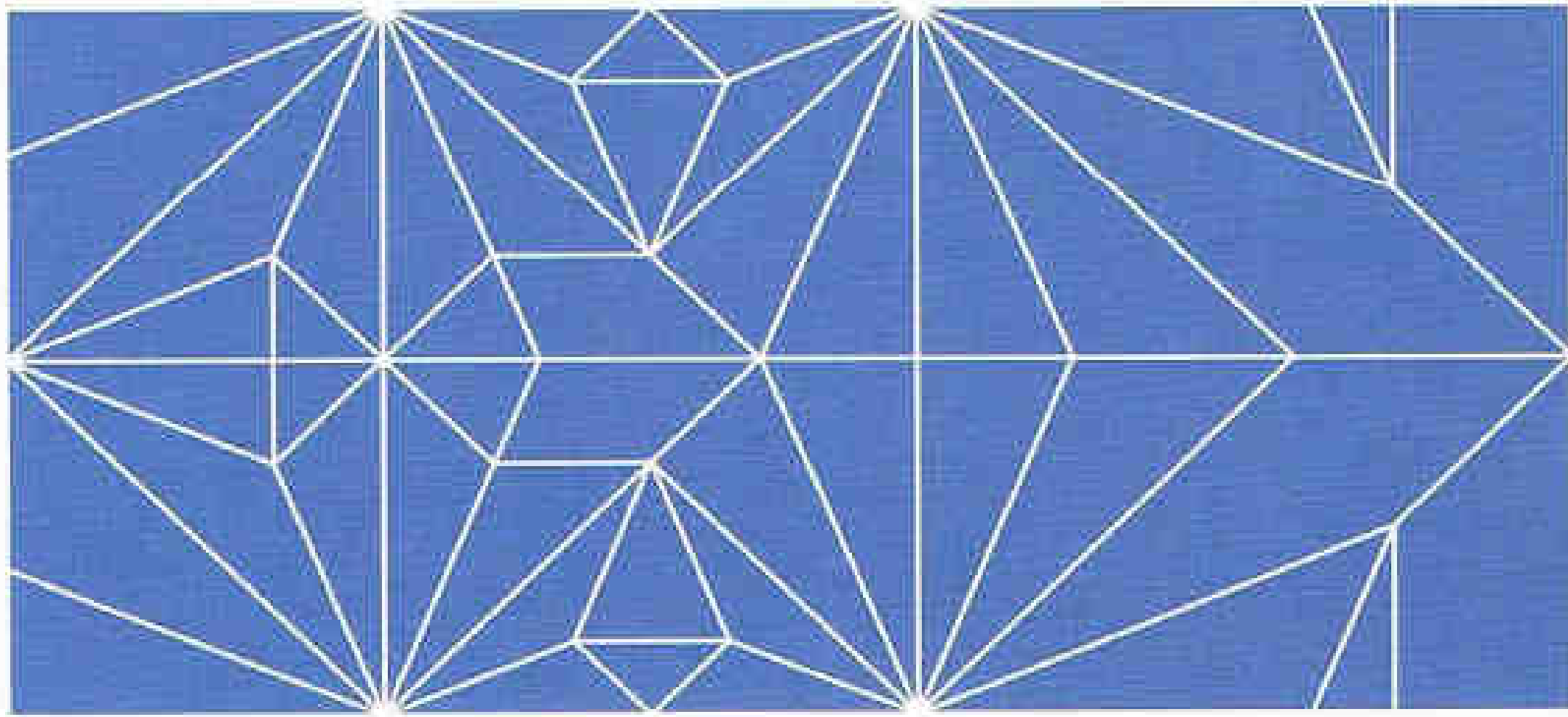

한국 작품

Korean - Origami

양 (Sheep)

창작가 : 유태용 (Yoo Tae Yong)

다이어그램 : 유태용 (Yoo Tae Yong)

창작일 : 2015.02.11

종이크기 : 20cm x 20cm

양을 창작할 때 가장 먼저 생각한 건, 뿔을 만들자는 것이었습니다. 뿔을 길게 뽑기 위해 여러번 시도를 해 봤지만, 길게 뿔을 만큼 머리 부분에 여분을 많이 남기는 게 문제였습니다. 그러다 간단하게 돼지를 창작할 때 사용한 기본형으로 다시 시도해 보면 좋을 것 같아 여러번 시도를 통해 완성하게 되었습니다.

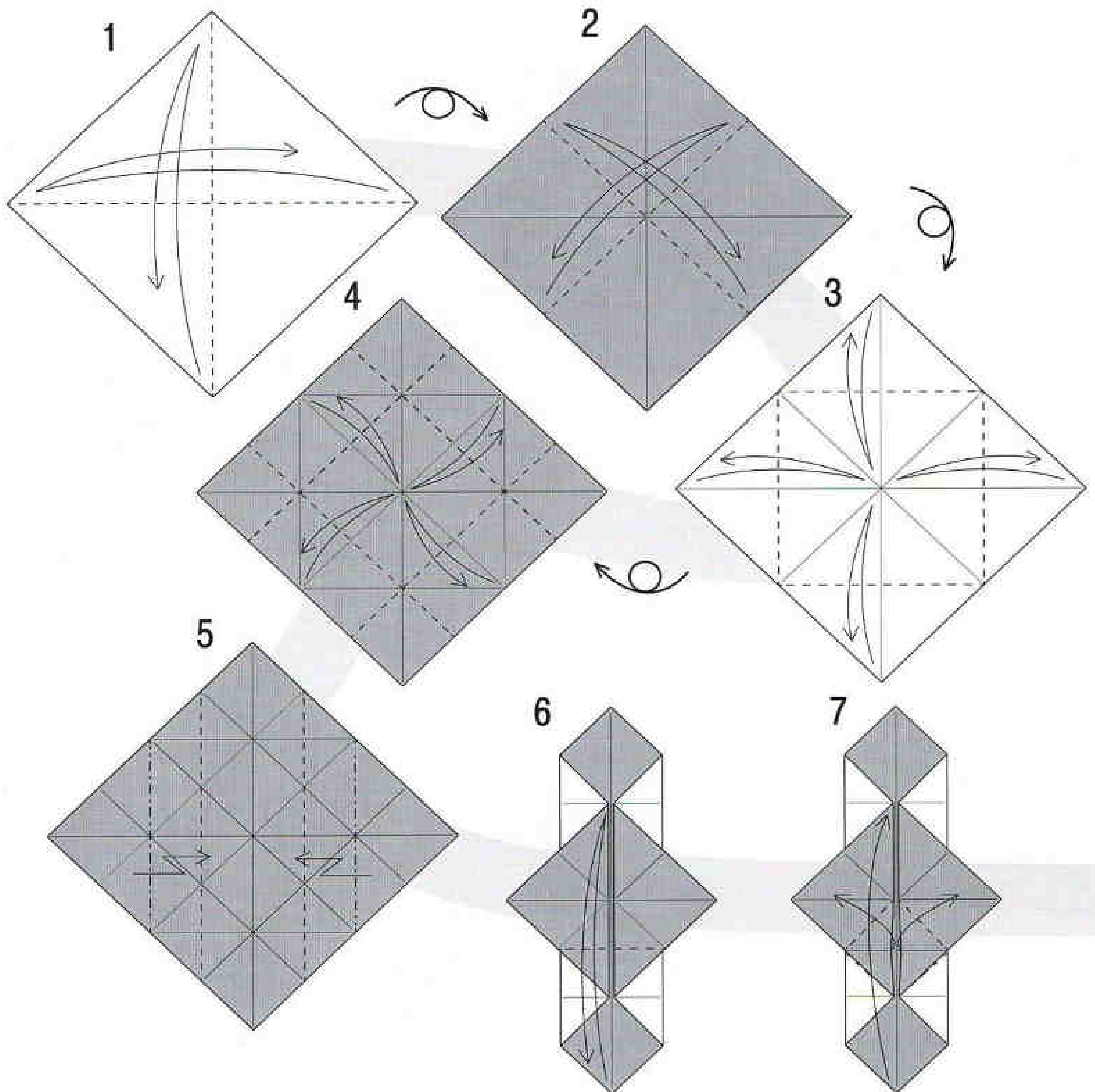
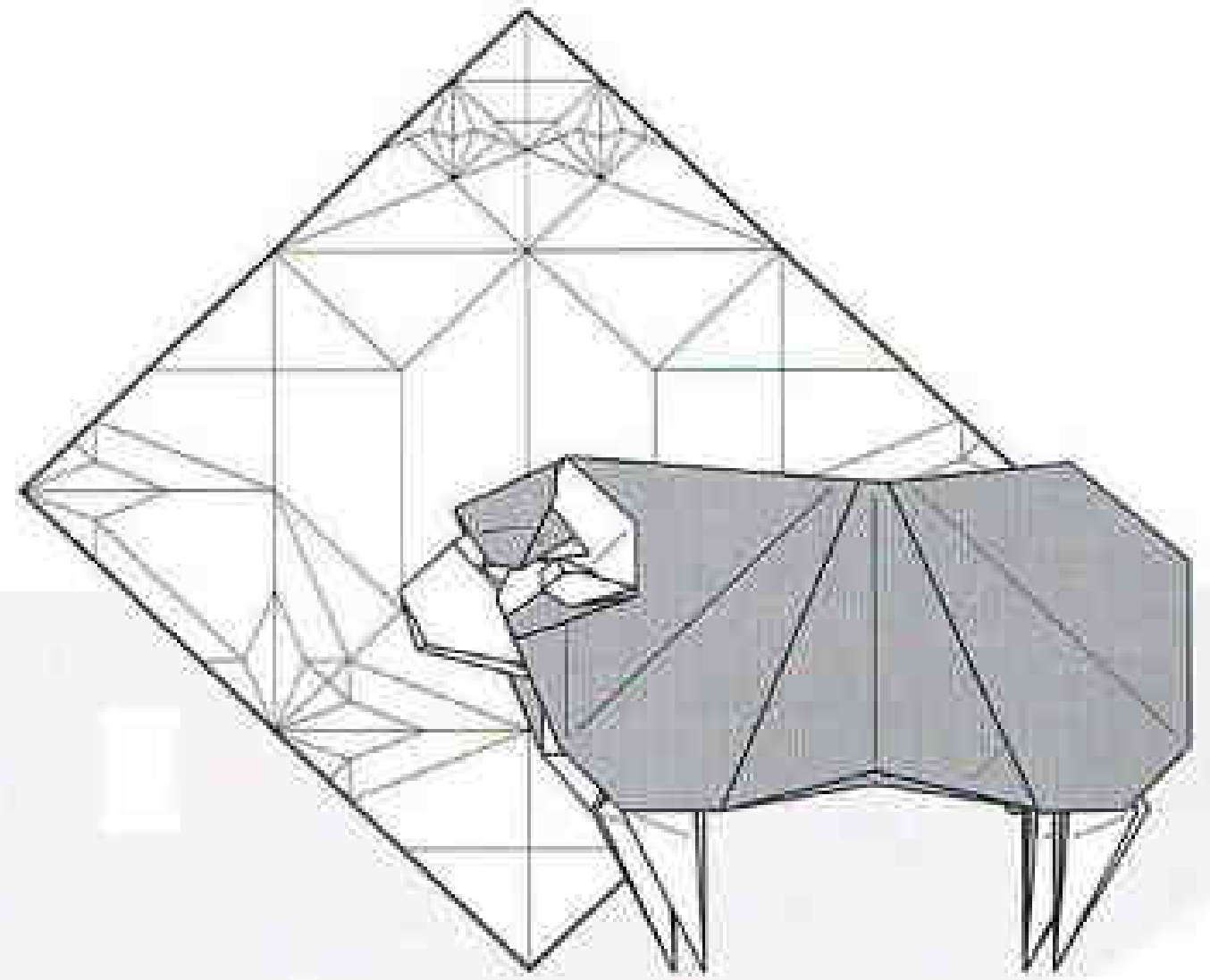

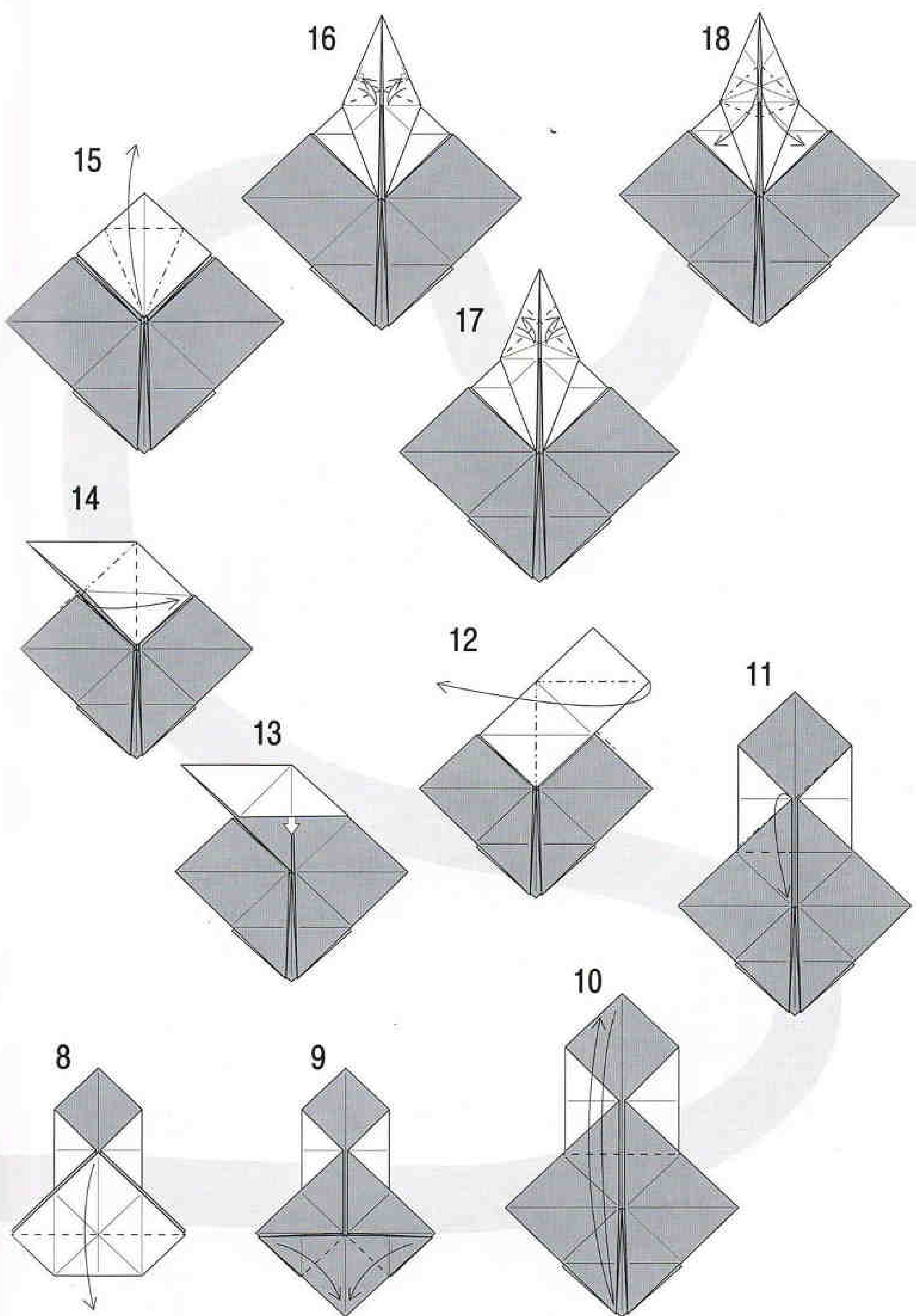

19

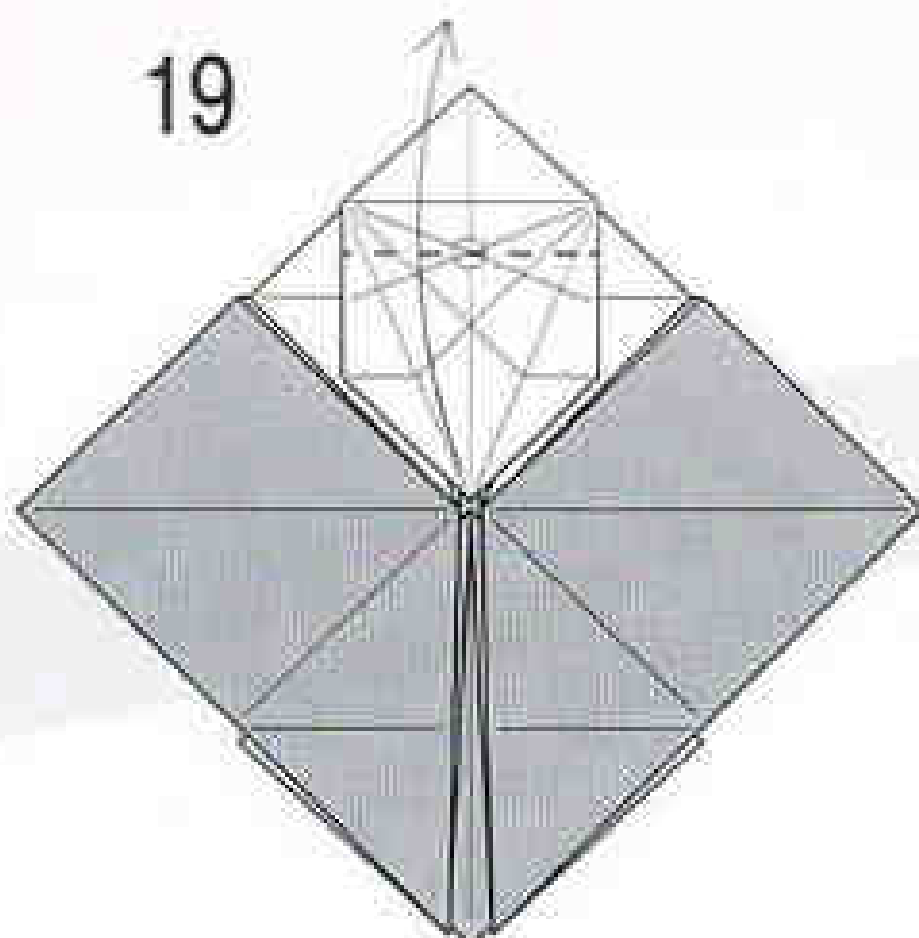

20

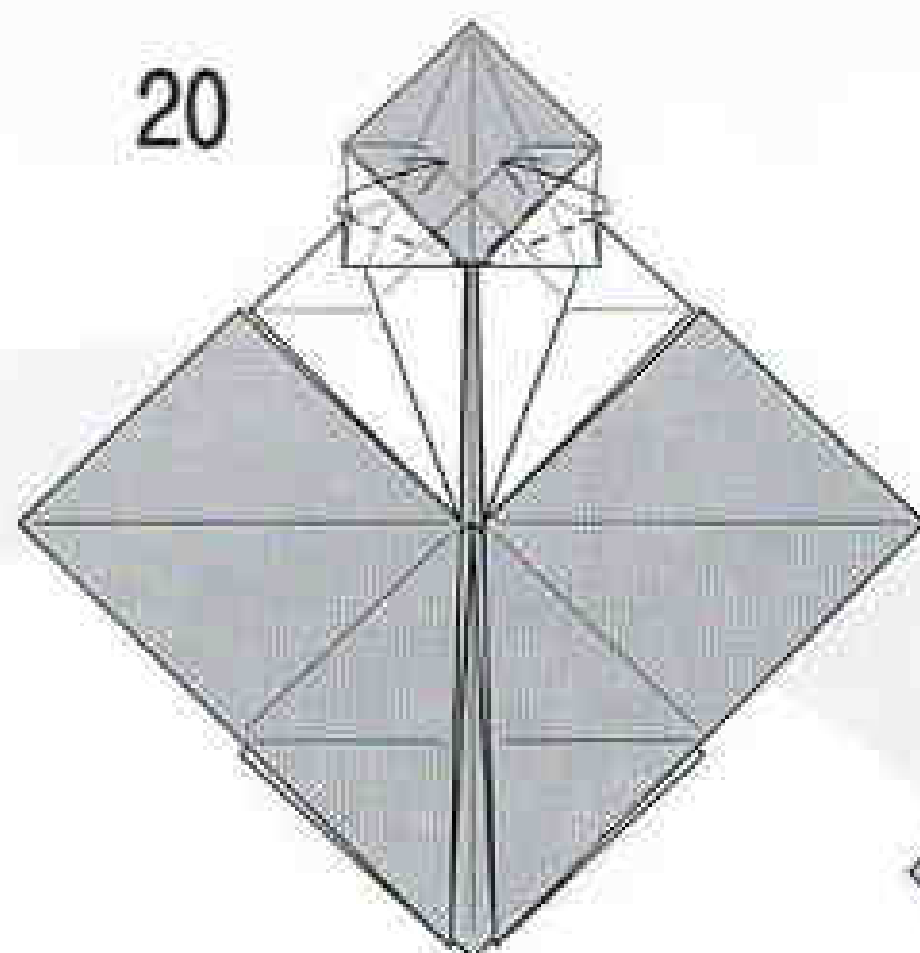

21

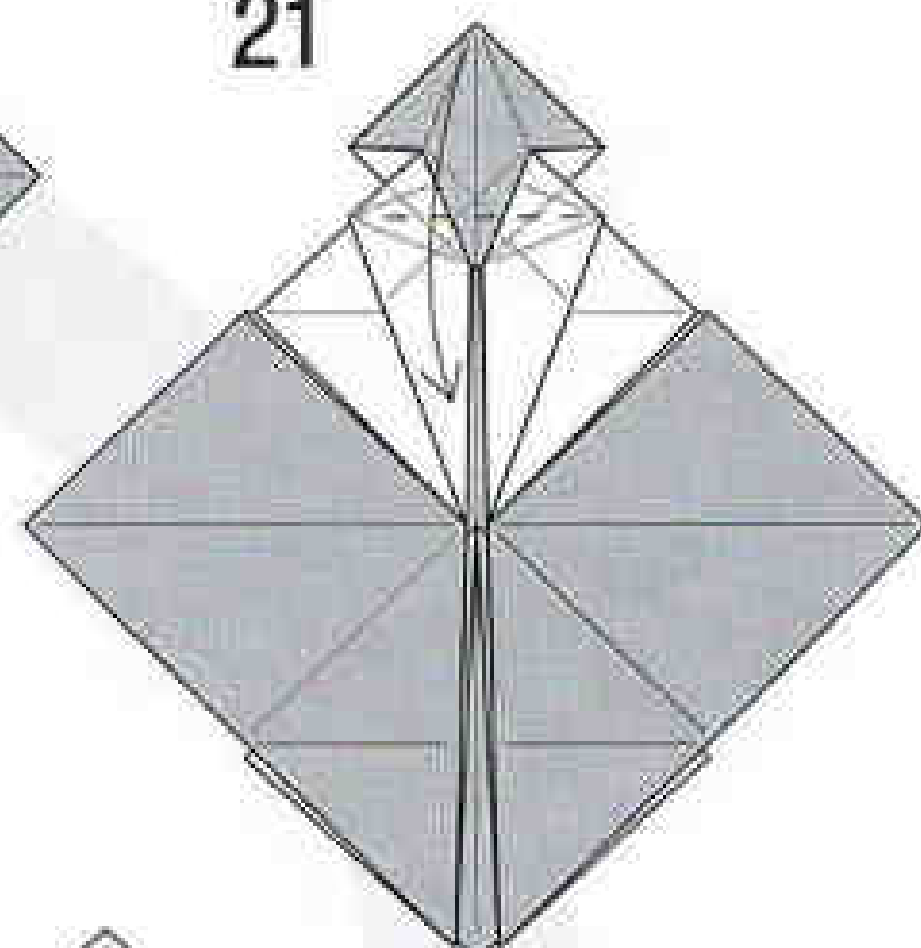

23

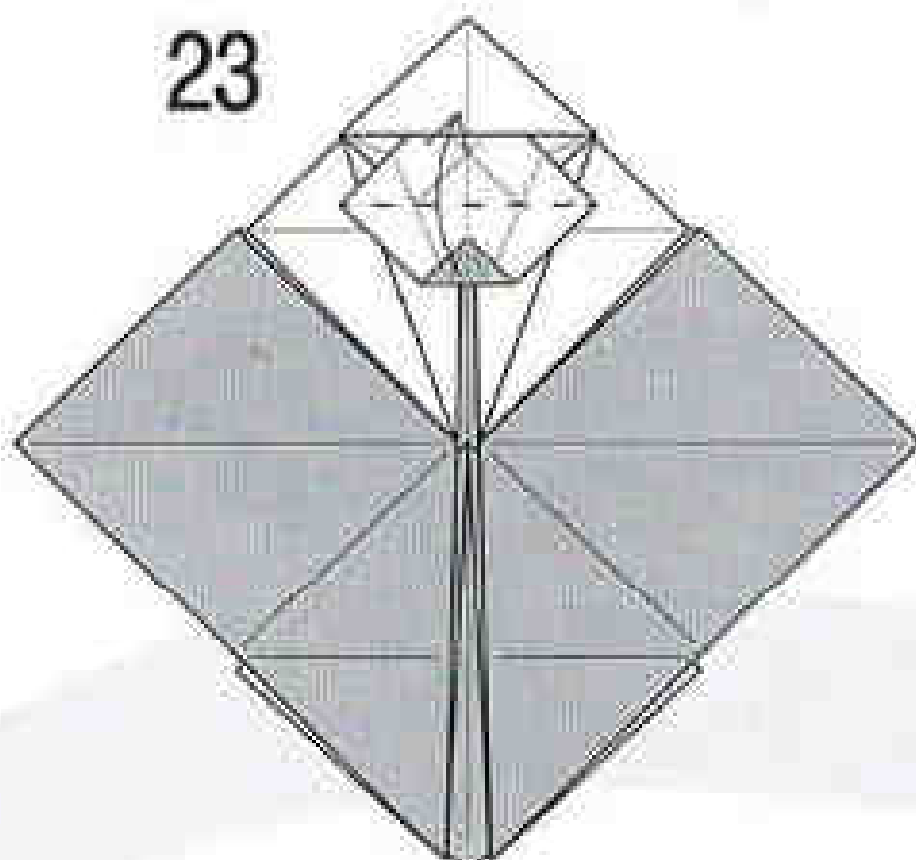

22

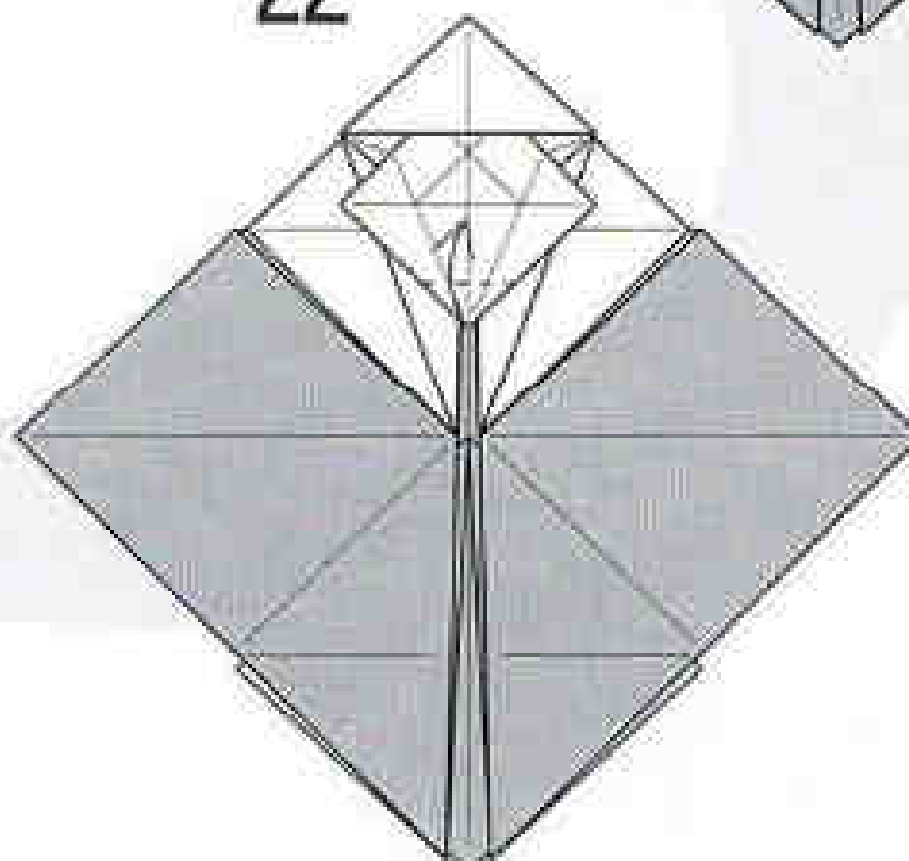

24

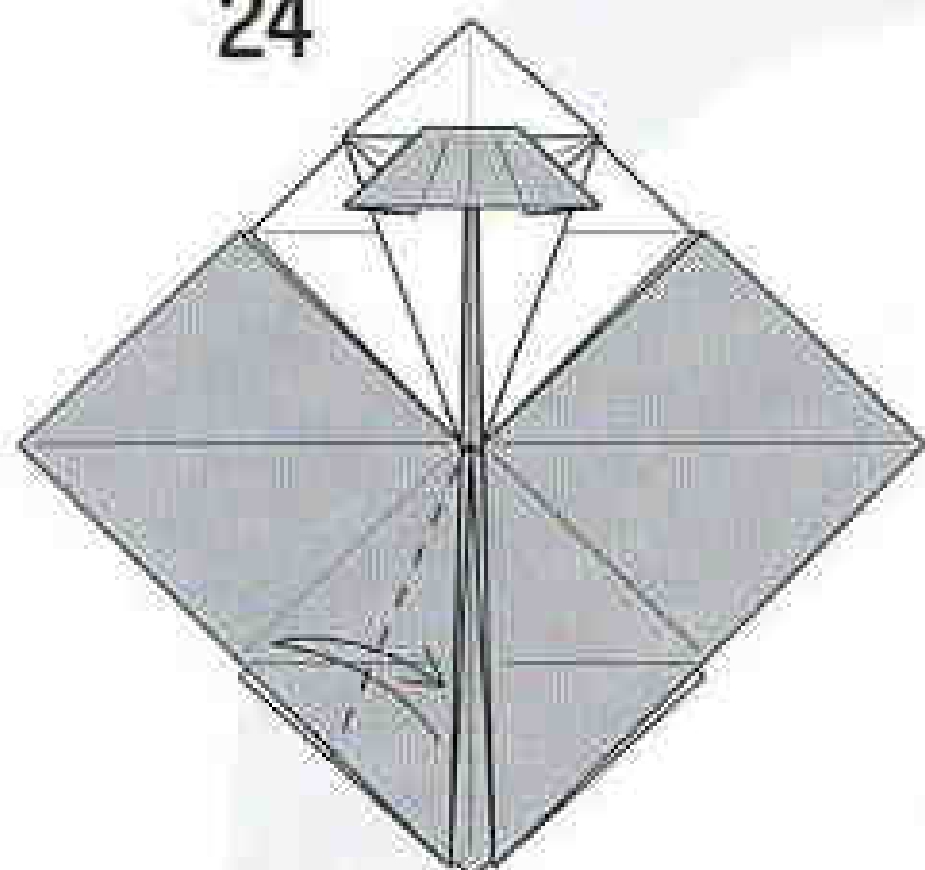

27

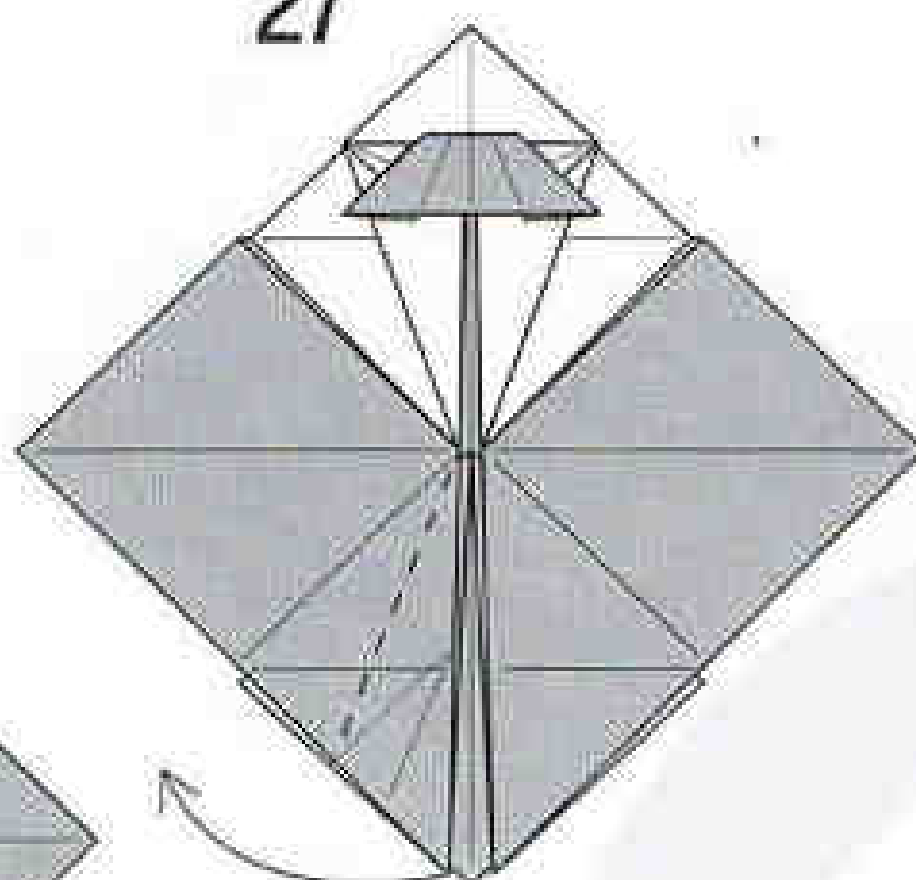

28

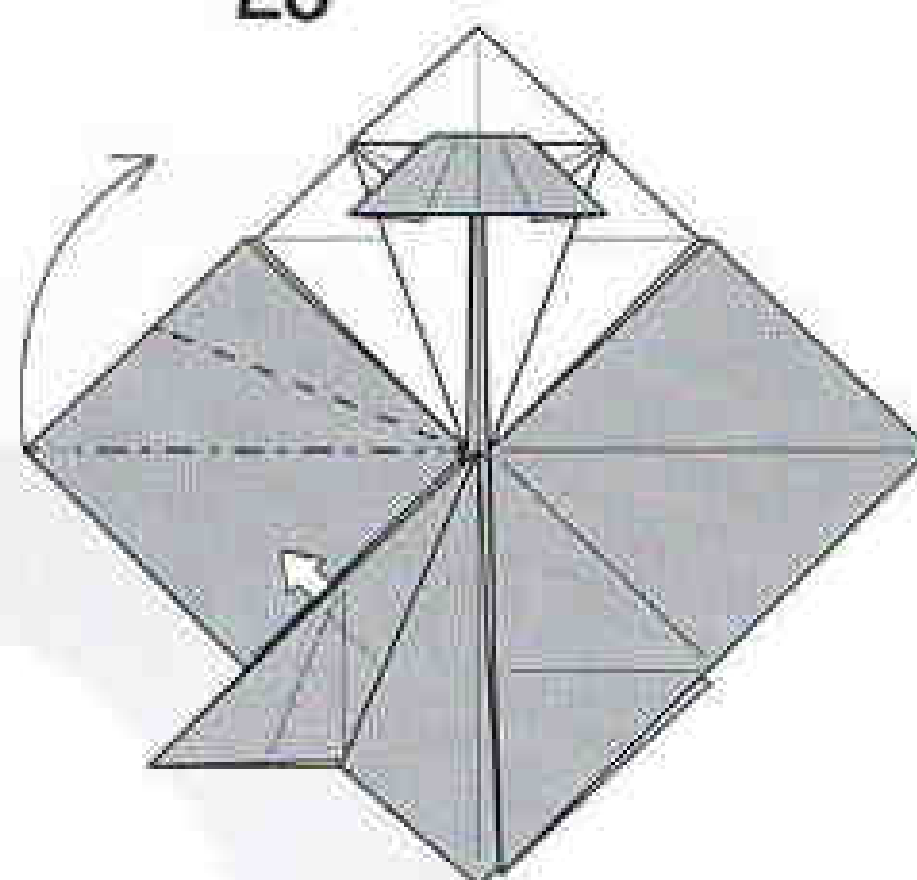

25

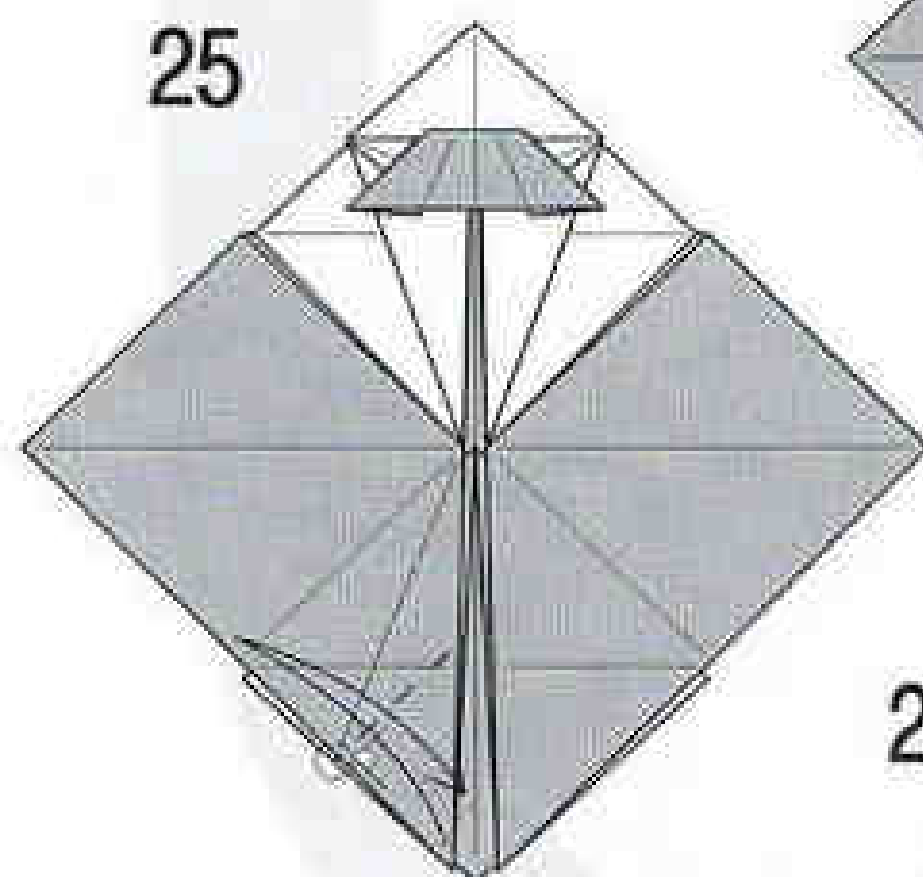

26

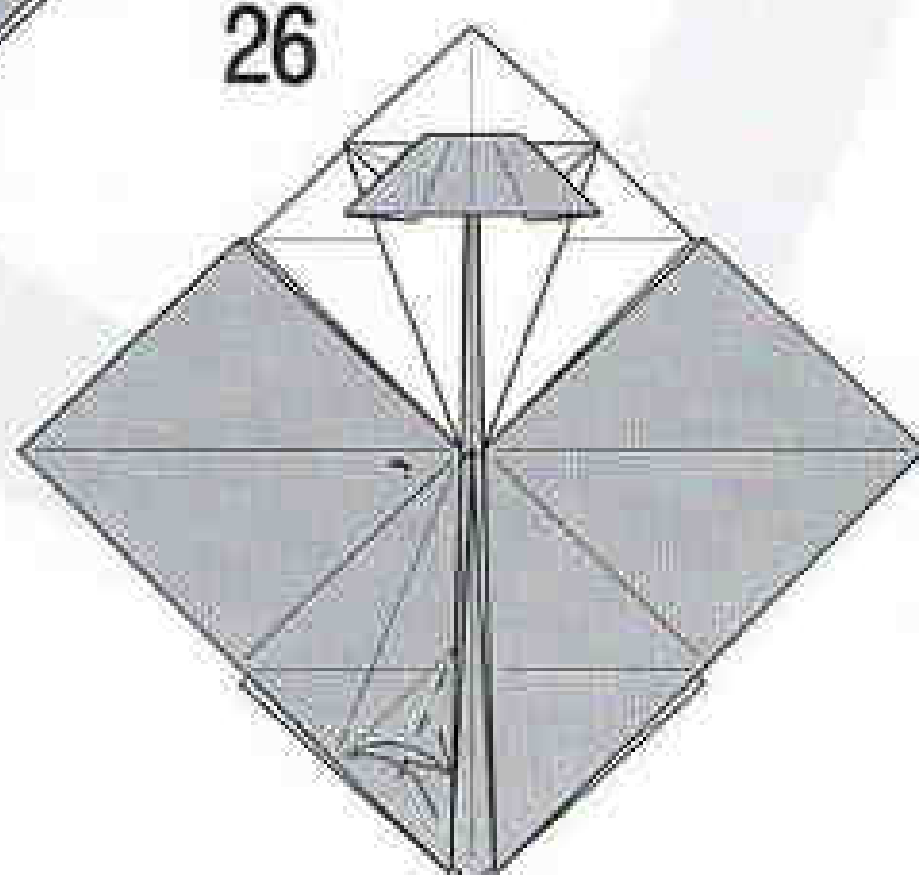

29

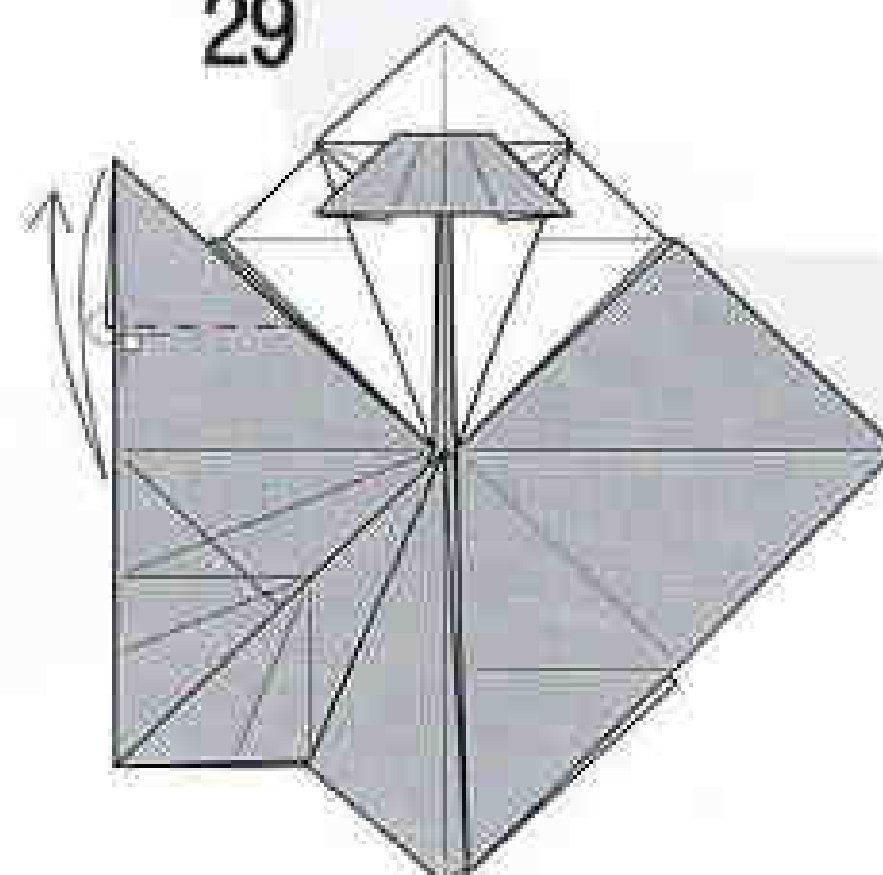

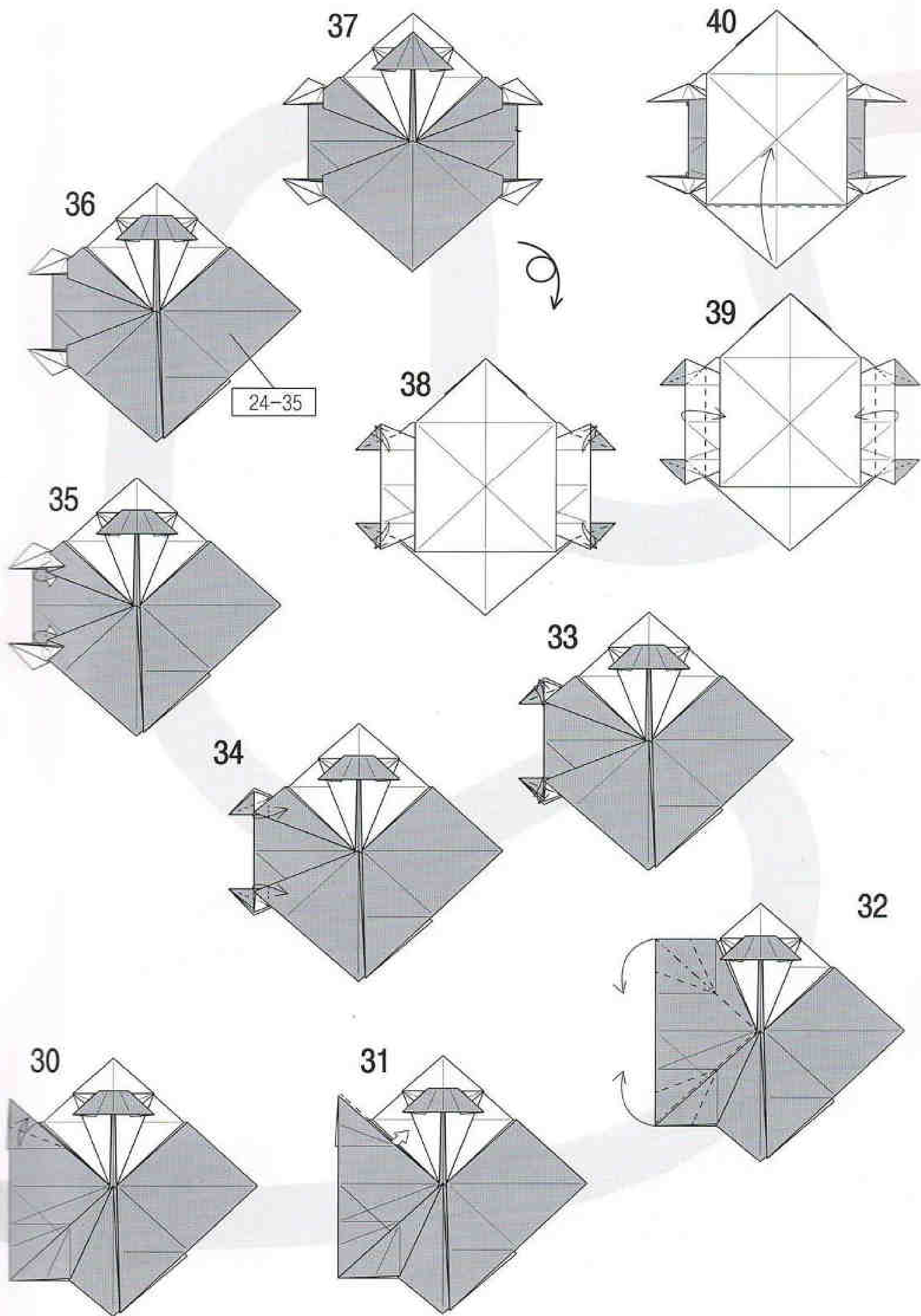

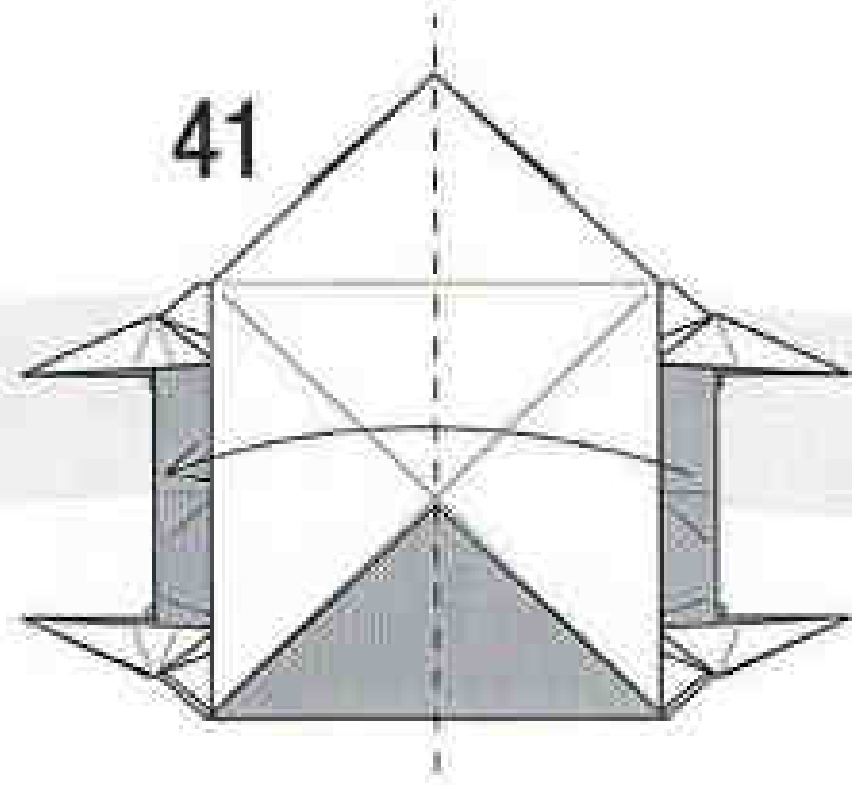

41

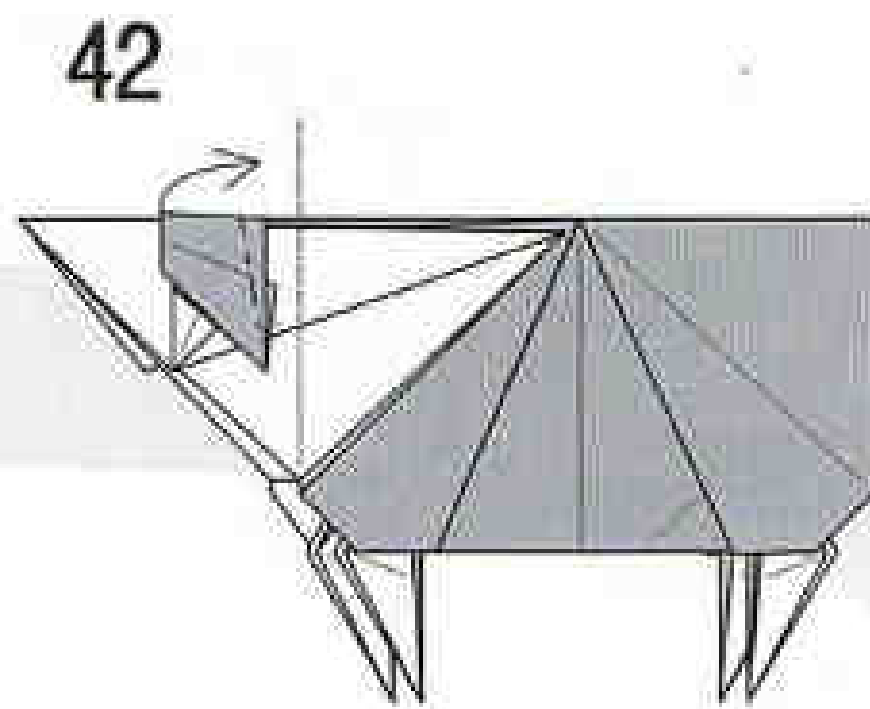

42

43

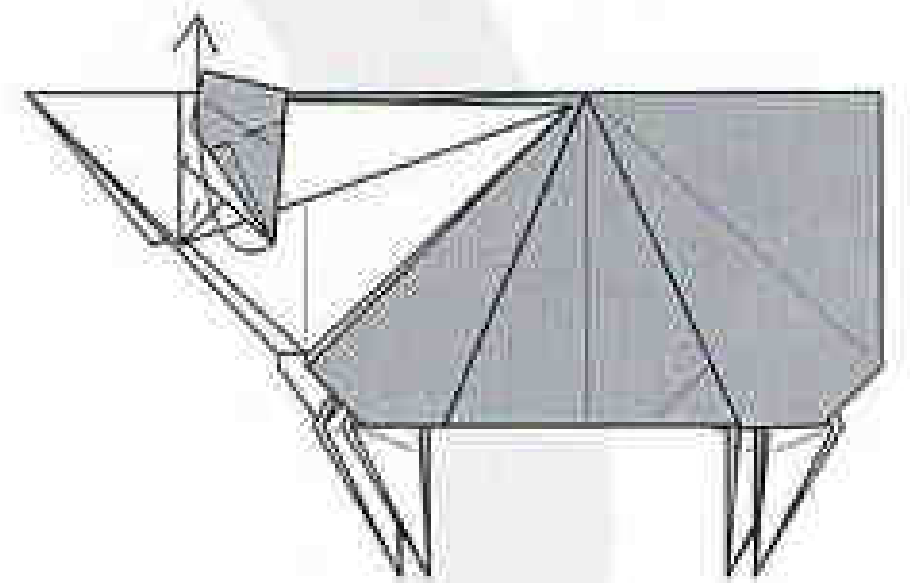

45

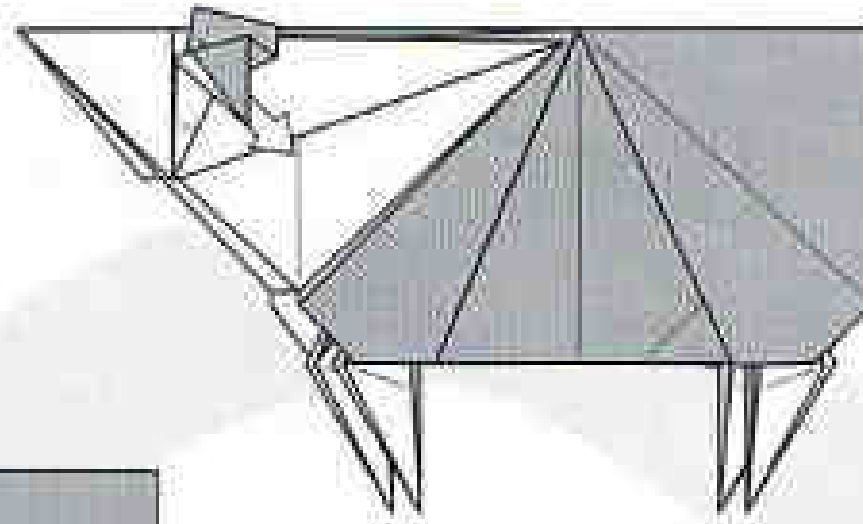

46

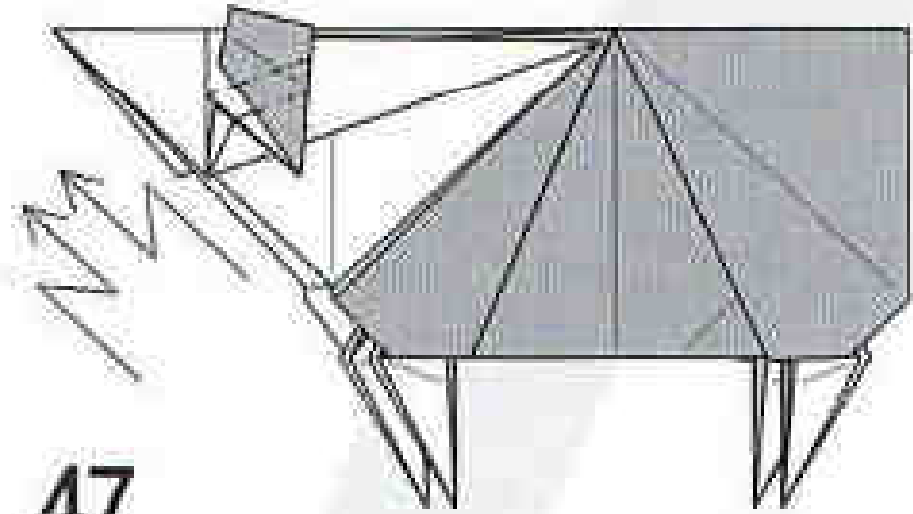

44

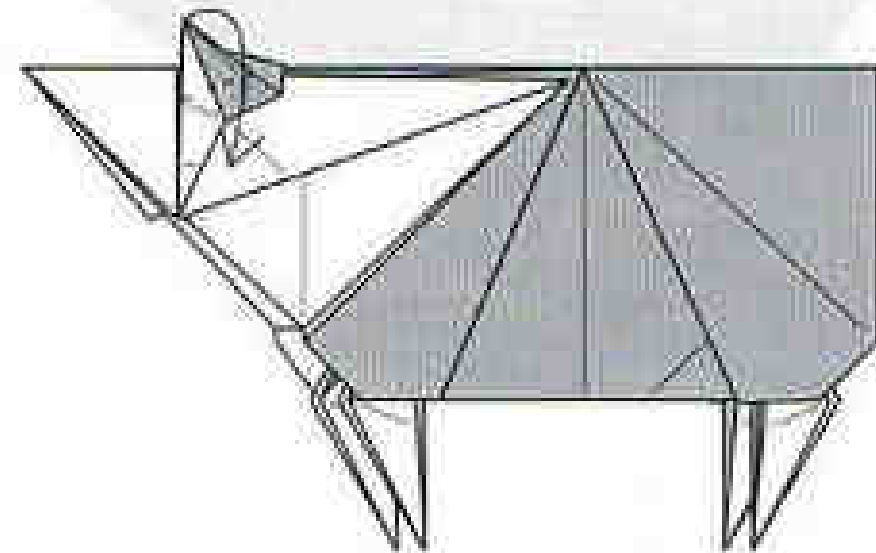

47

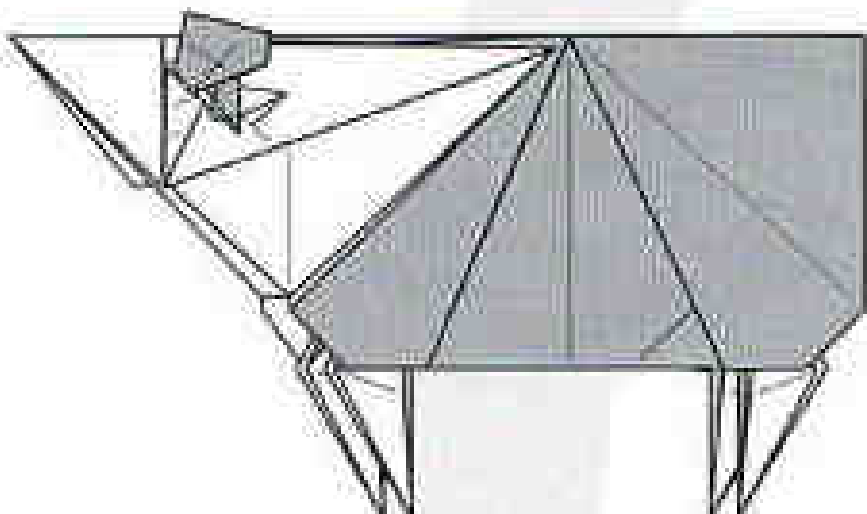

51

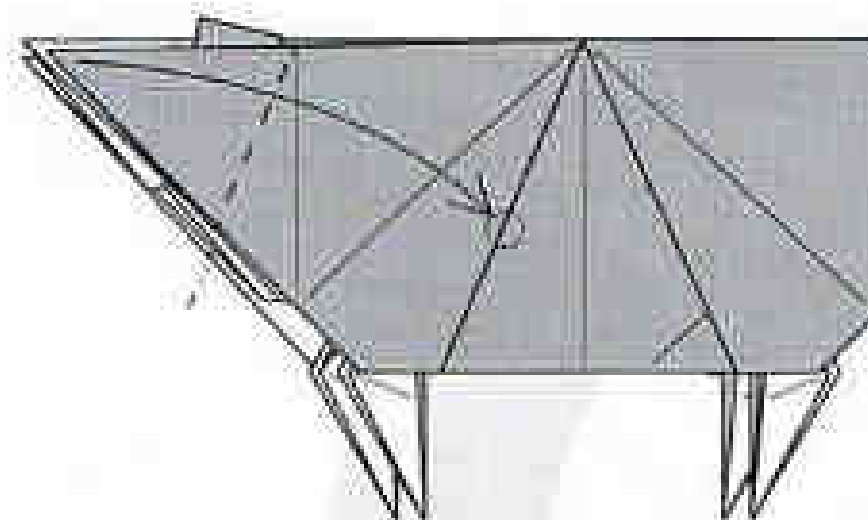

48

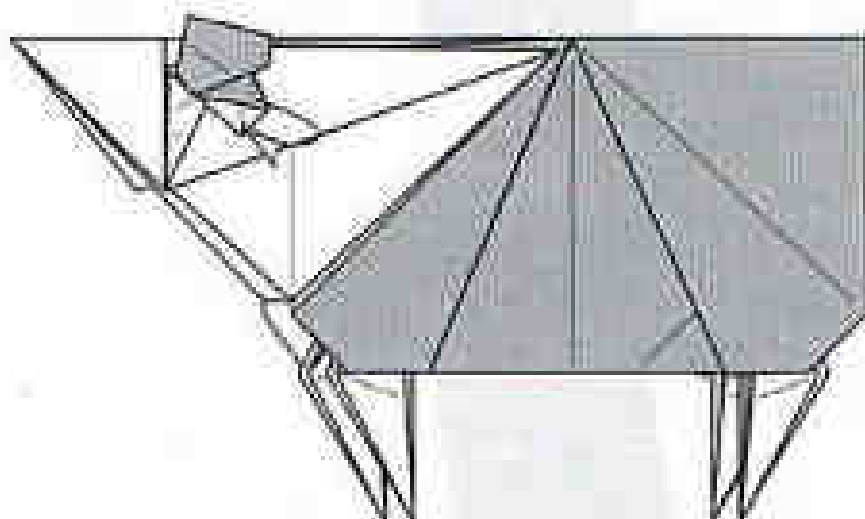

52

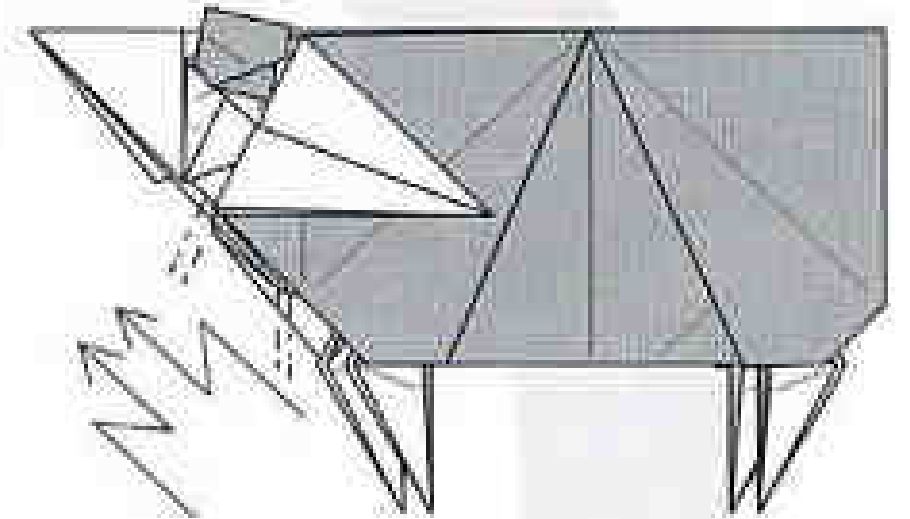

50

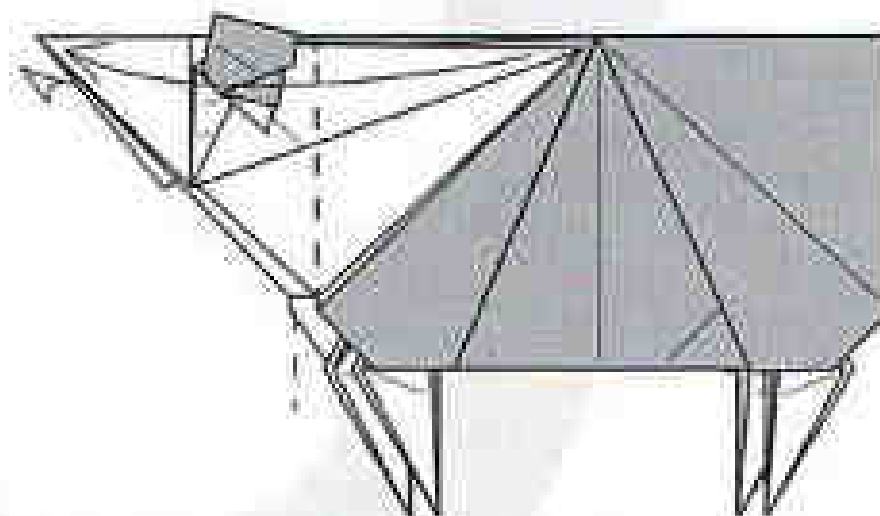

49

53

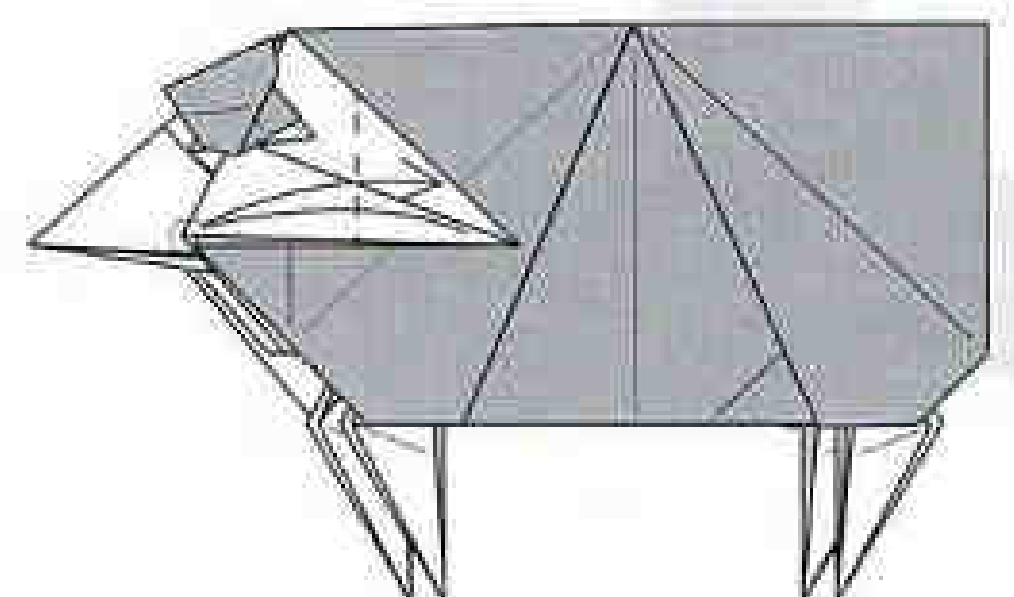

43-48

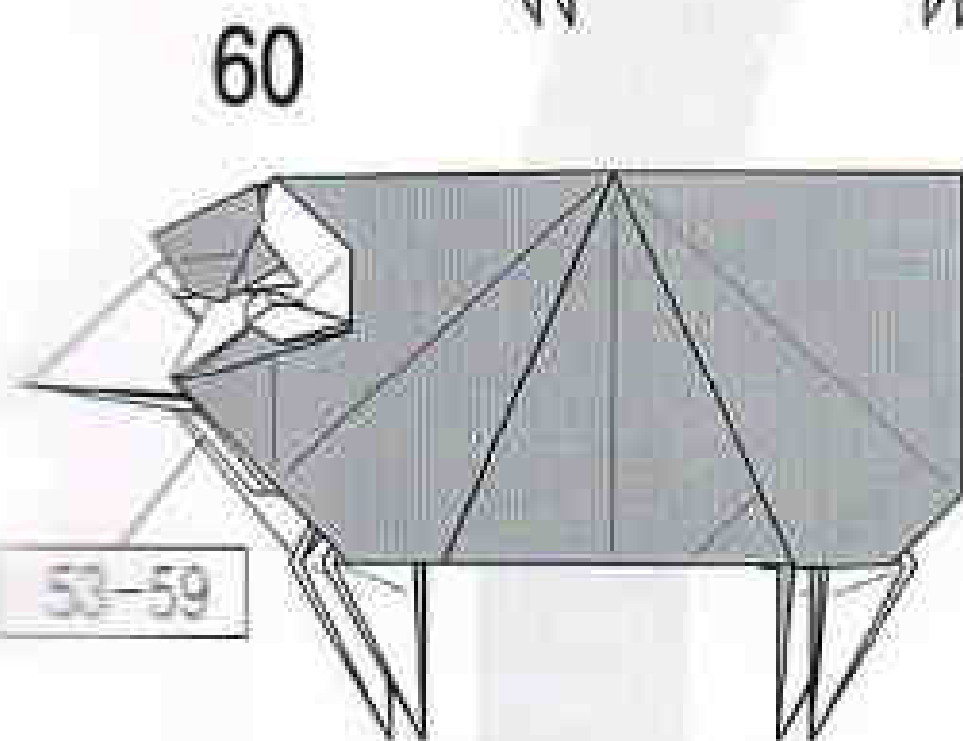
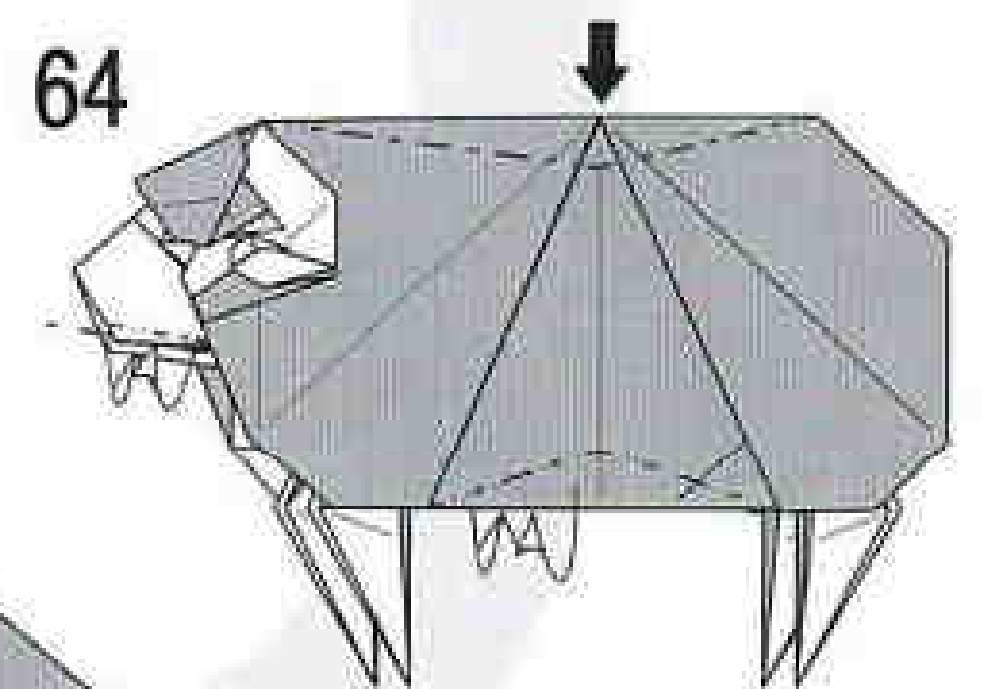
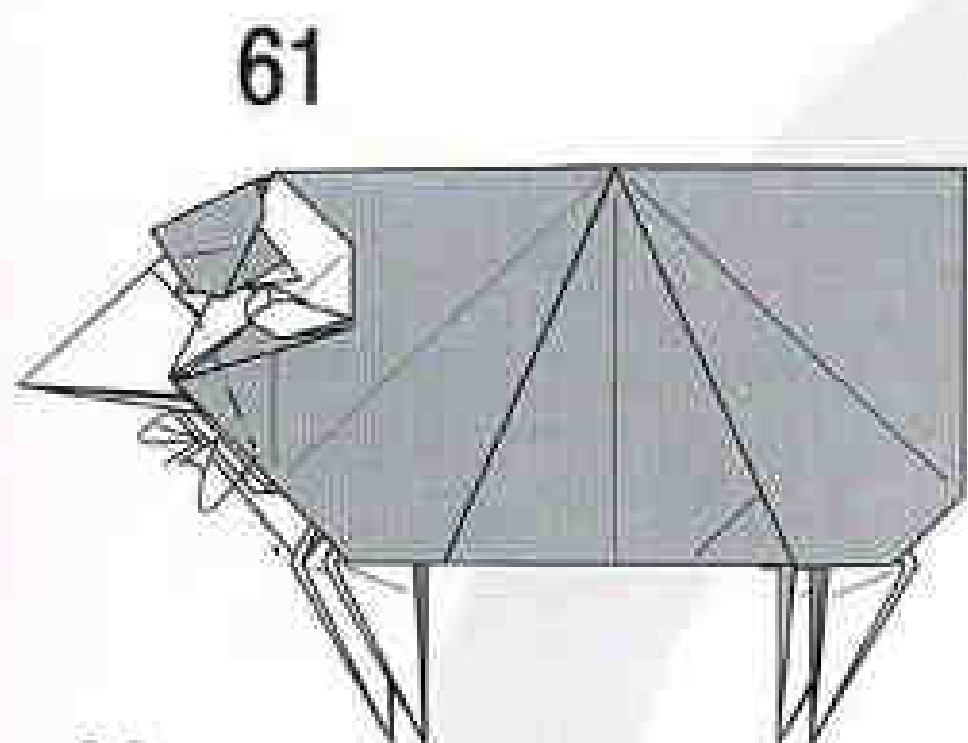
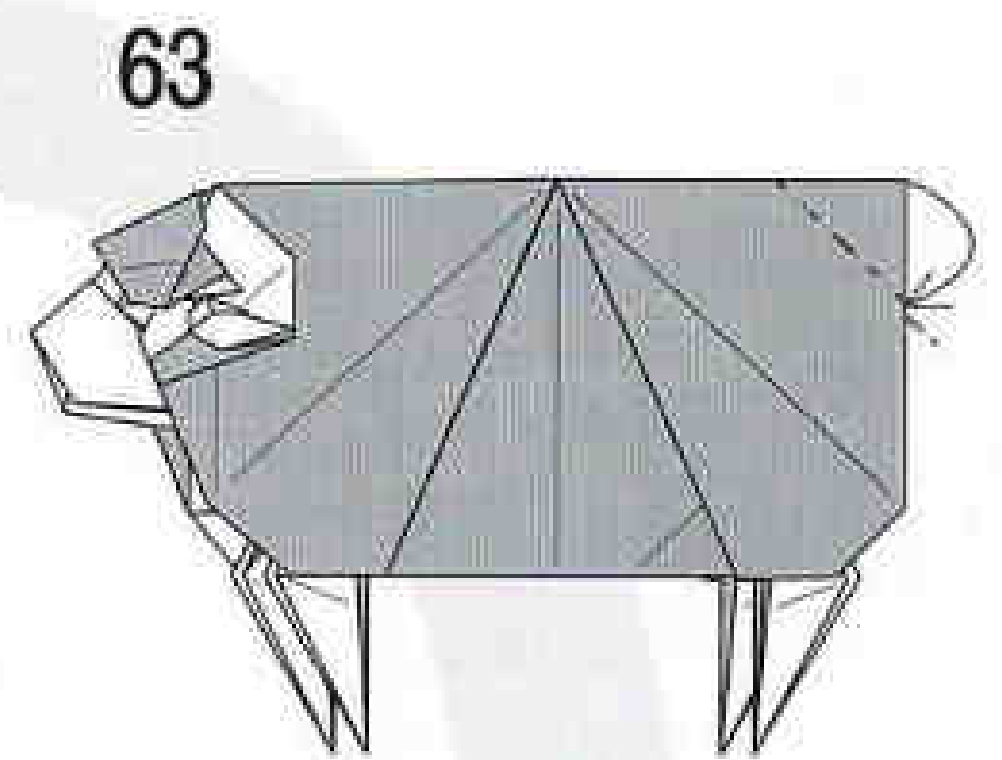
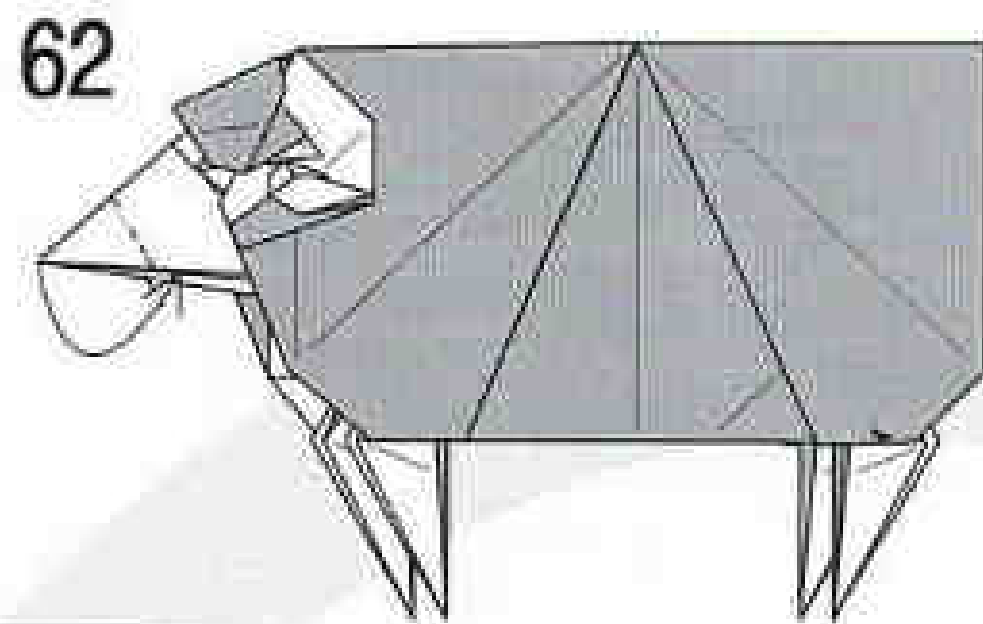

완성

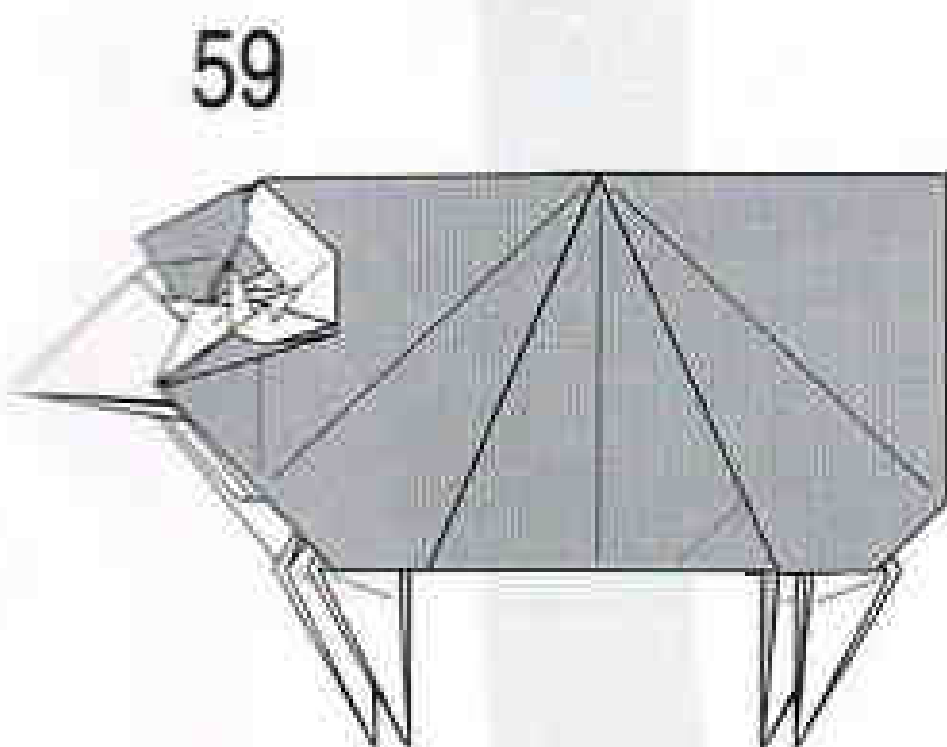
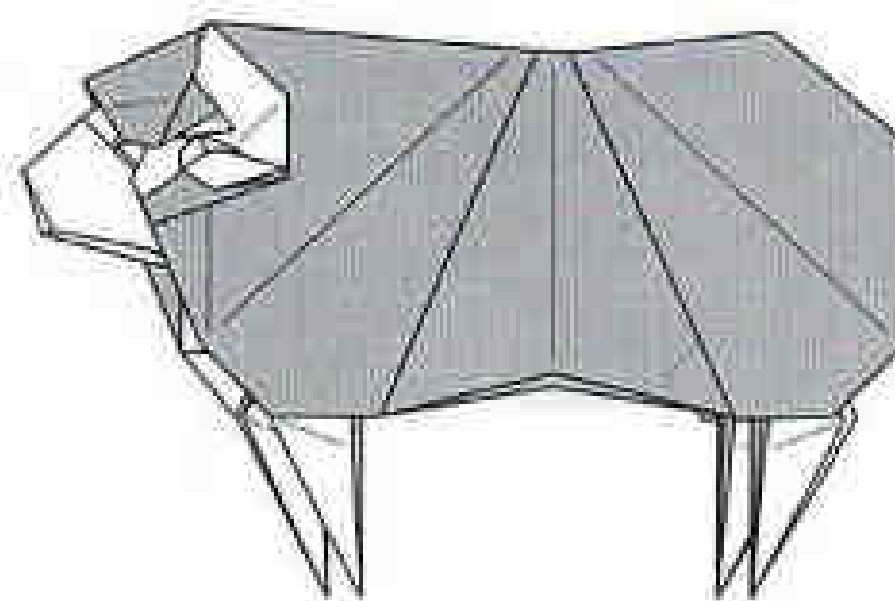

57

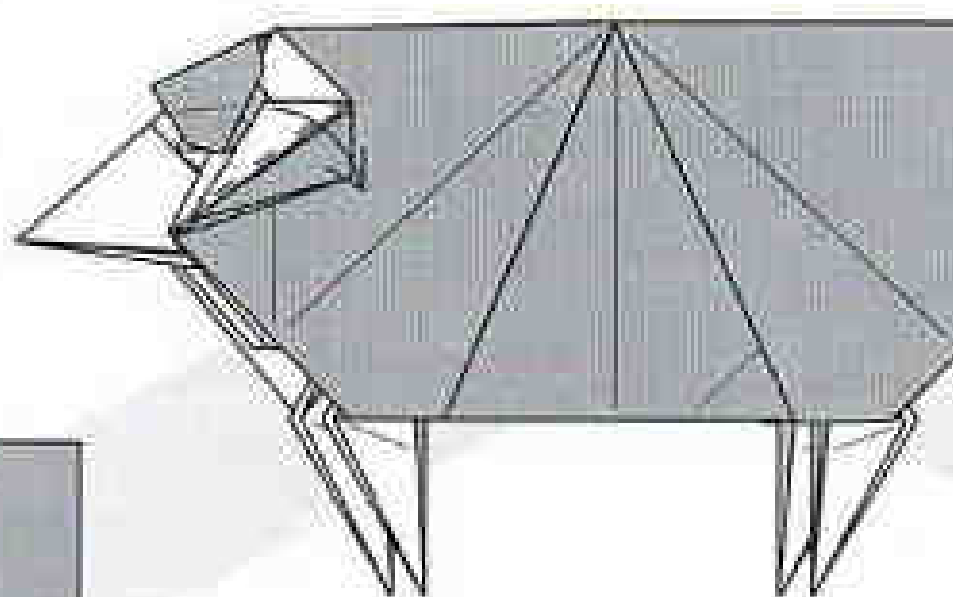

58

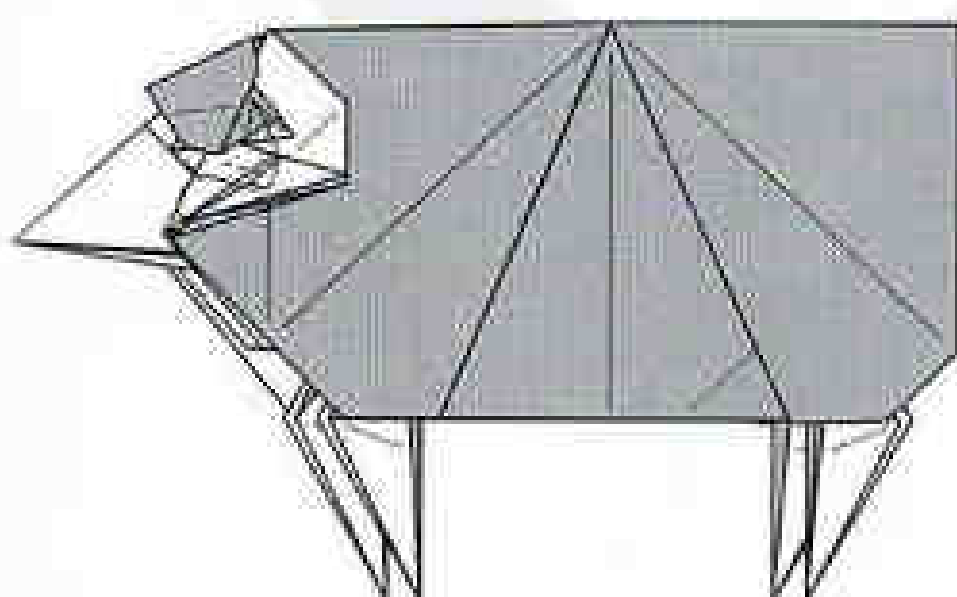

56

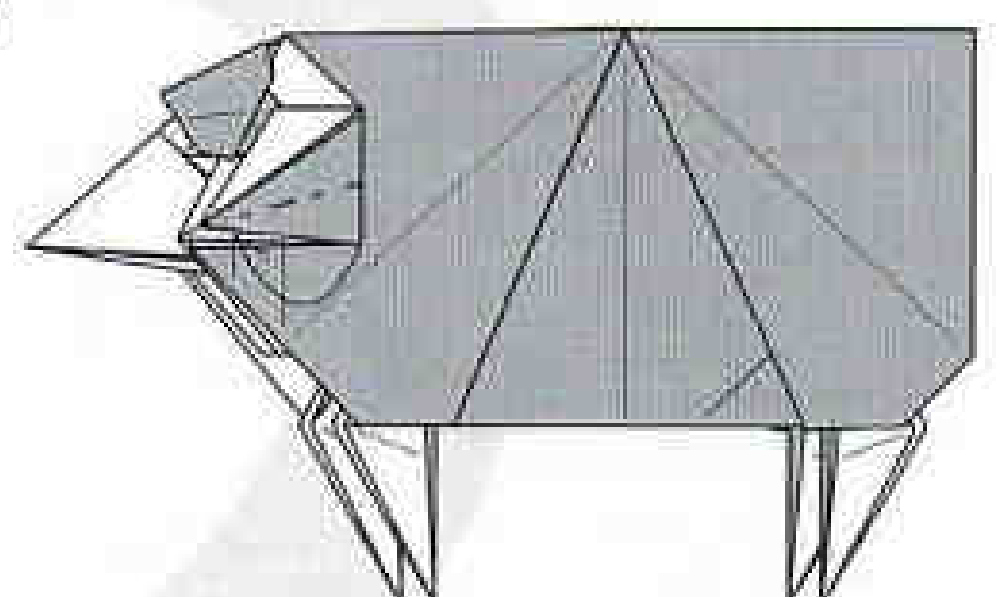

54

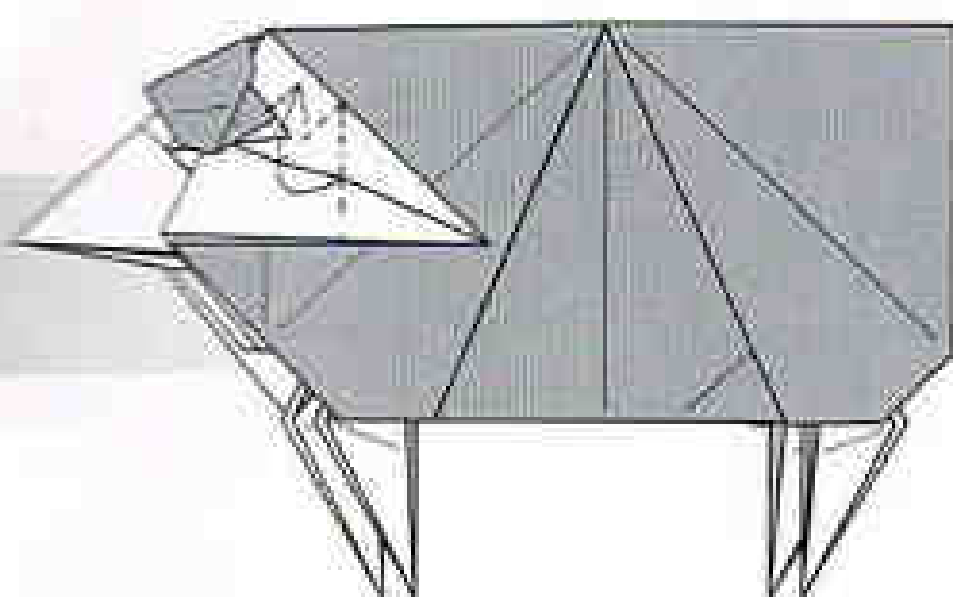

55

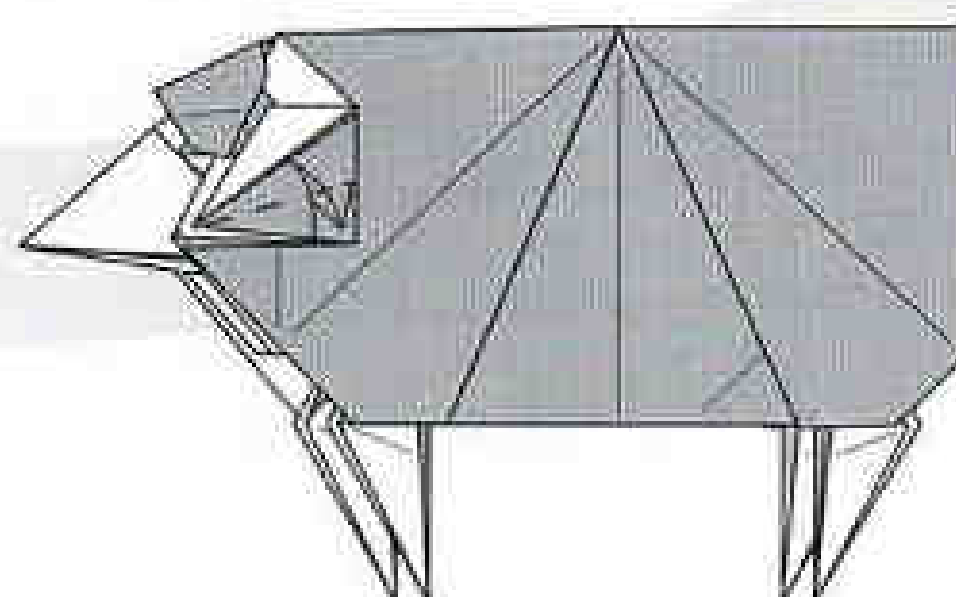

돼지 (Pig)

창작가 : 유태용 (Yoo Tae Yong)

다이어그램 : 유태용 (Yoo Tae Yong)

창작일 : 2015.02.11

종이크기 : 20cm x 20cm

수많은 돼지 작품을 보면 콧구멍이 표현되지 않은 작품이 많이 있습니다. 그렇기 때문에 콧구멍을 표현하면 돼지의 특징이 보다 잘 표현될 것 같아 콧구멍부터 접으며 창작했습니다. 몸통은 생각보다 간단하게 창작이 가능했습니다.

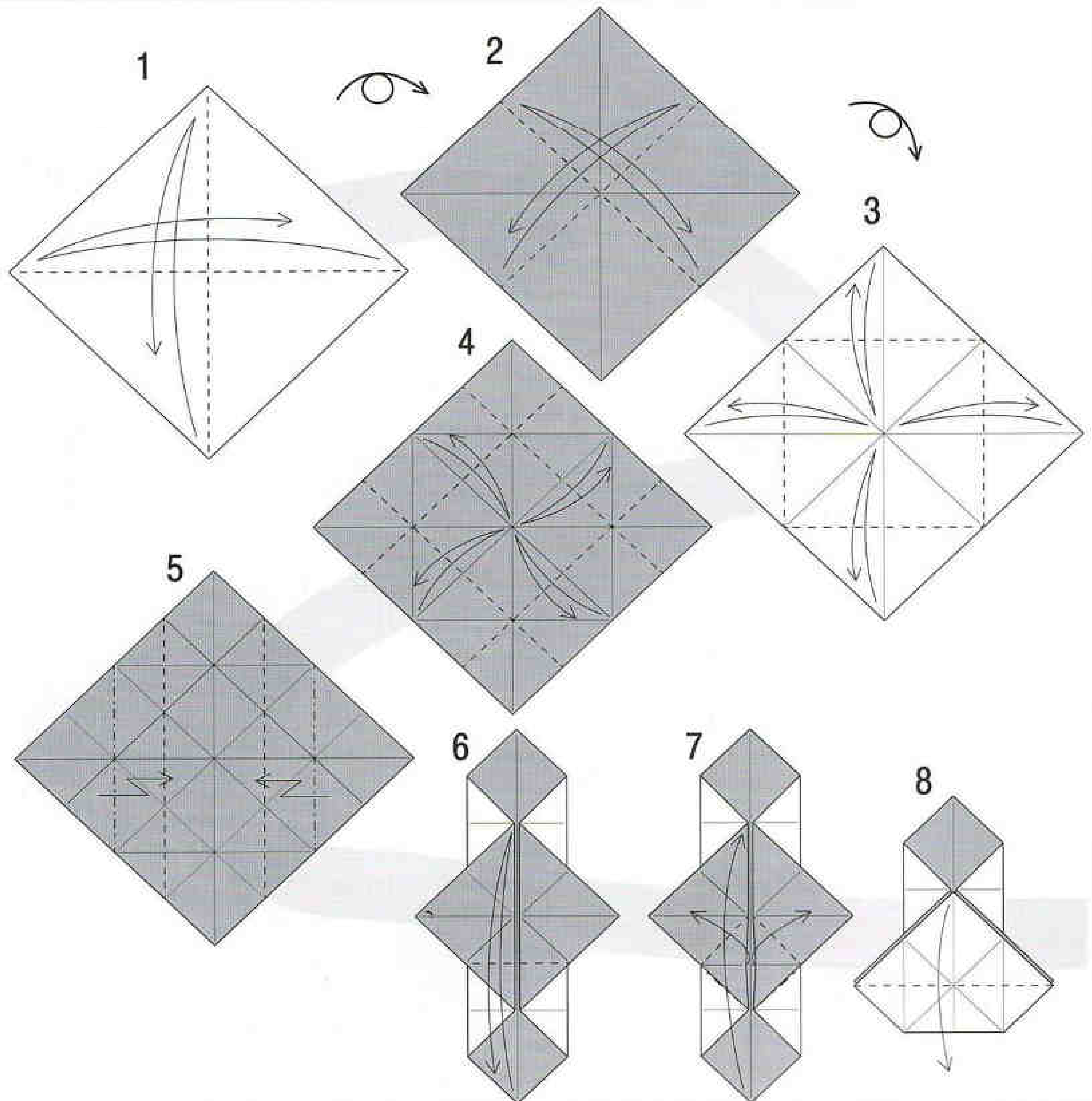
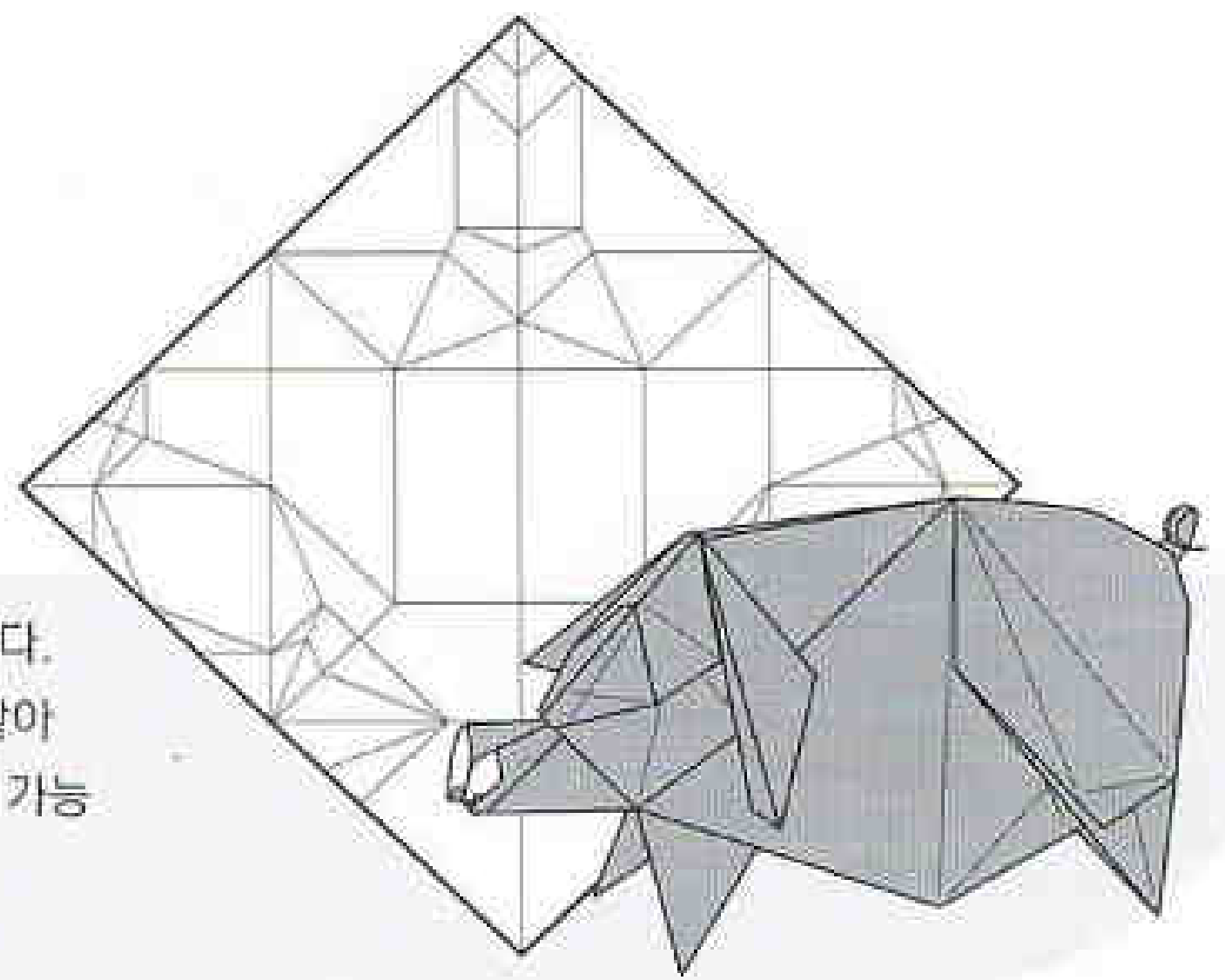

18

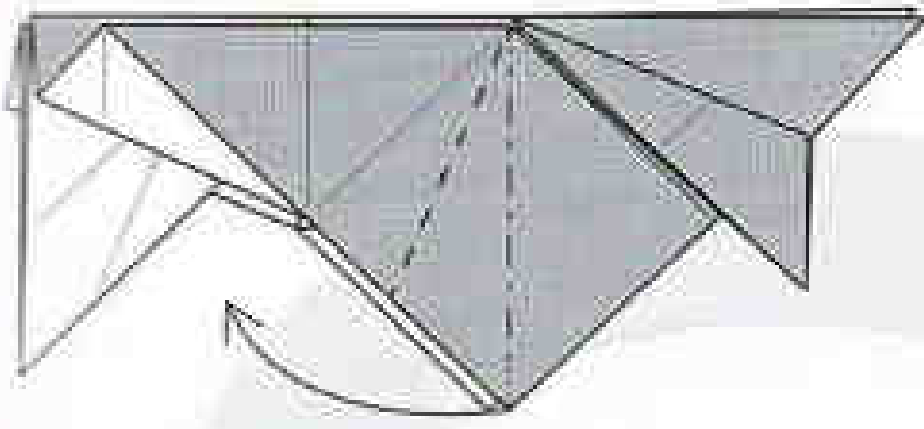

19

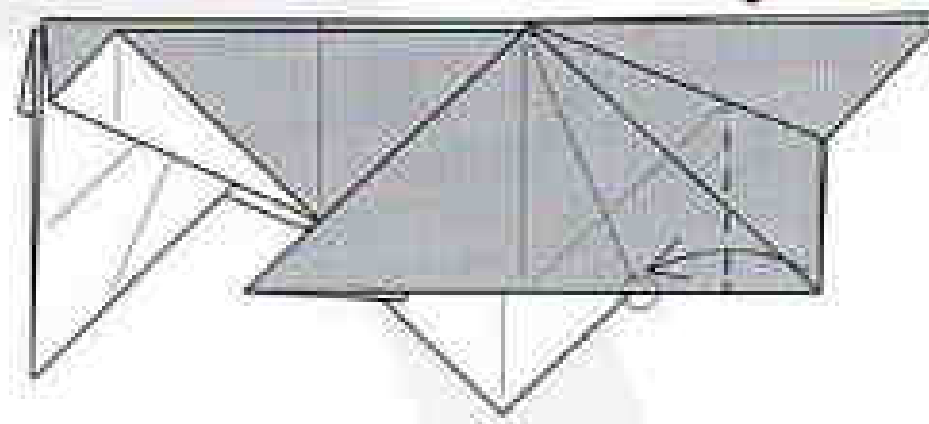

21

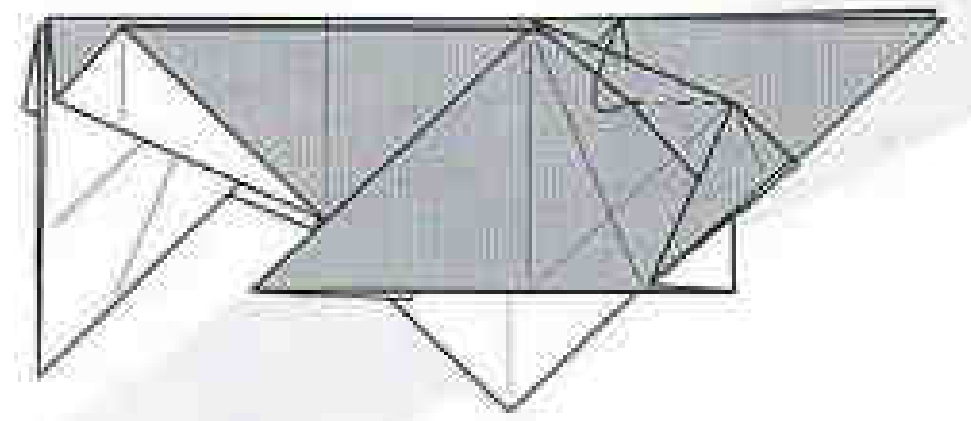

17

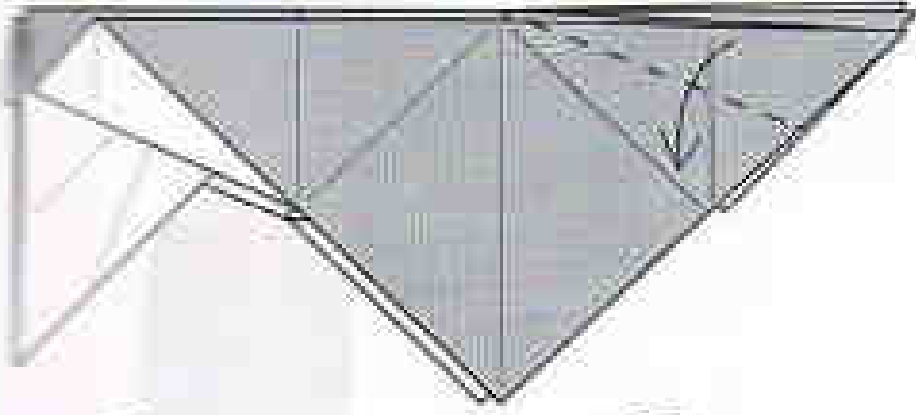

20

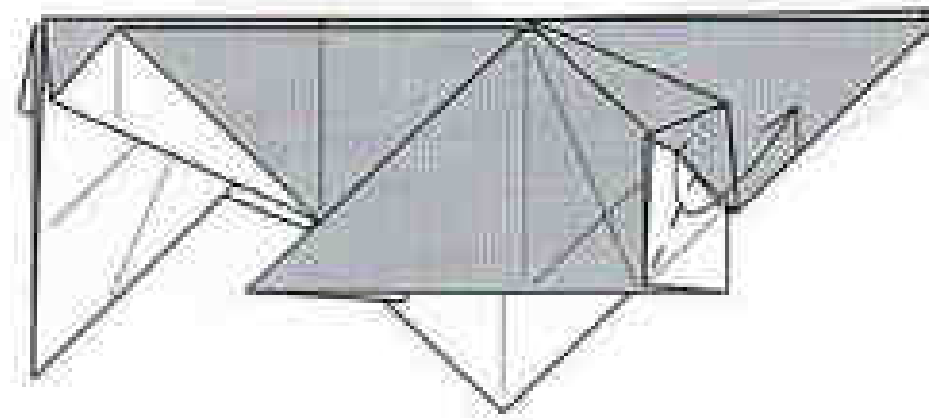

16

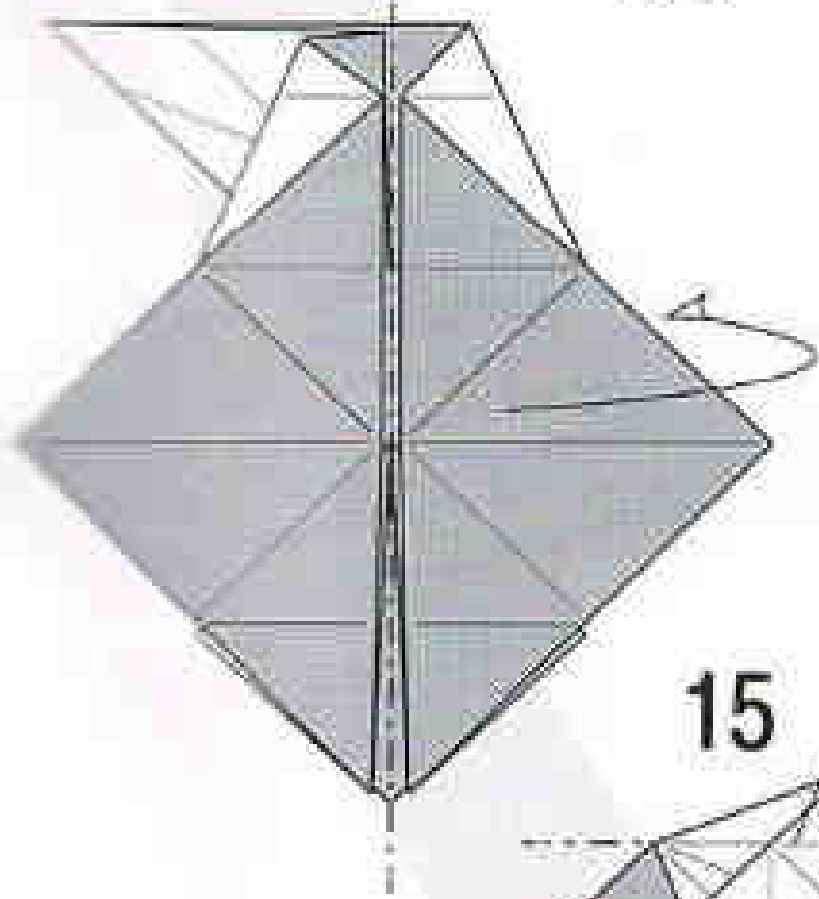

15

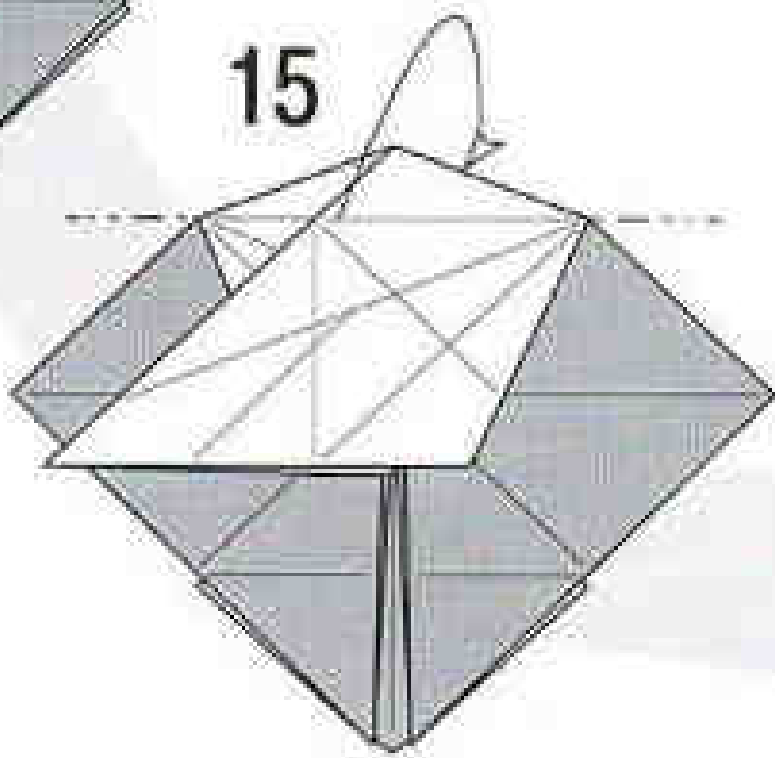

14

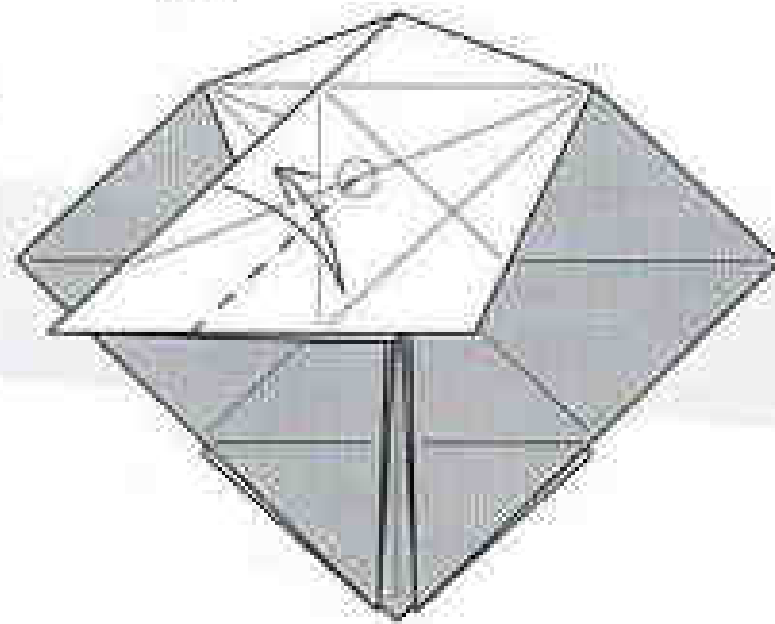

13

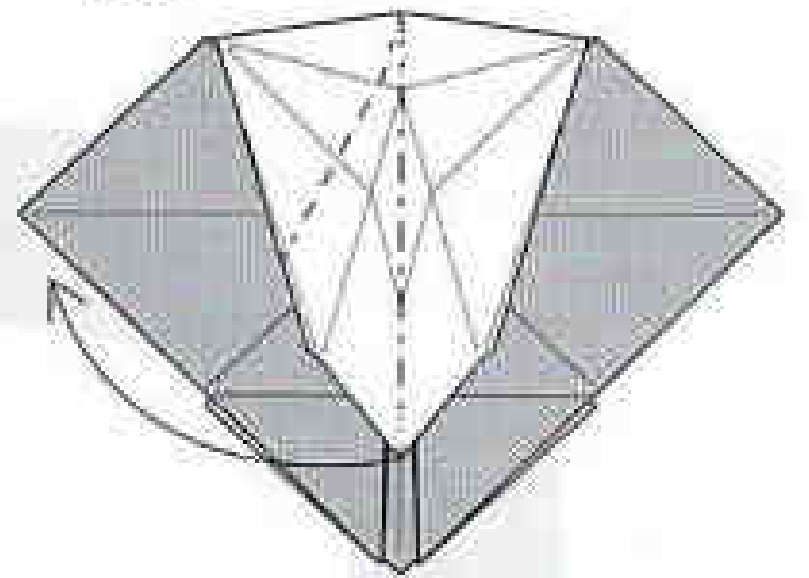

9

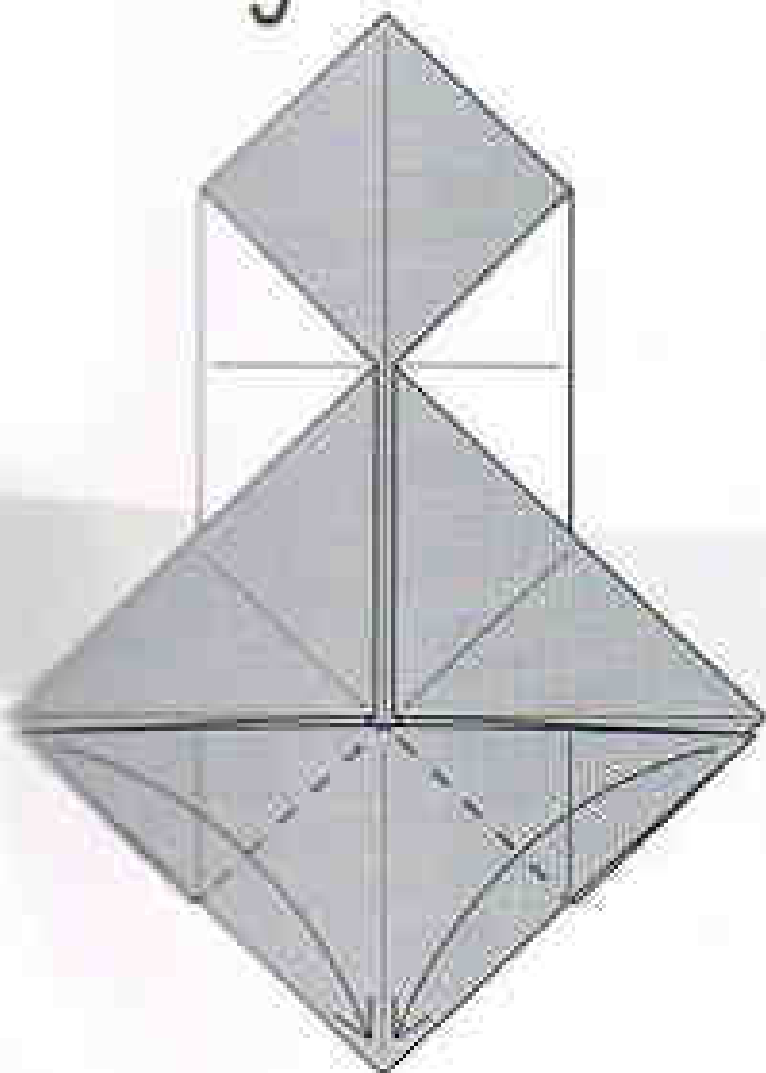

10

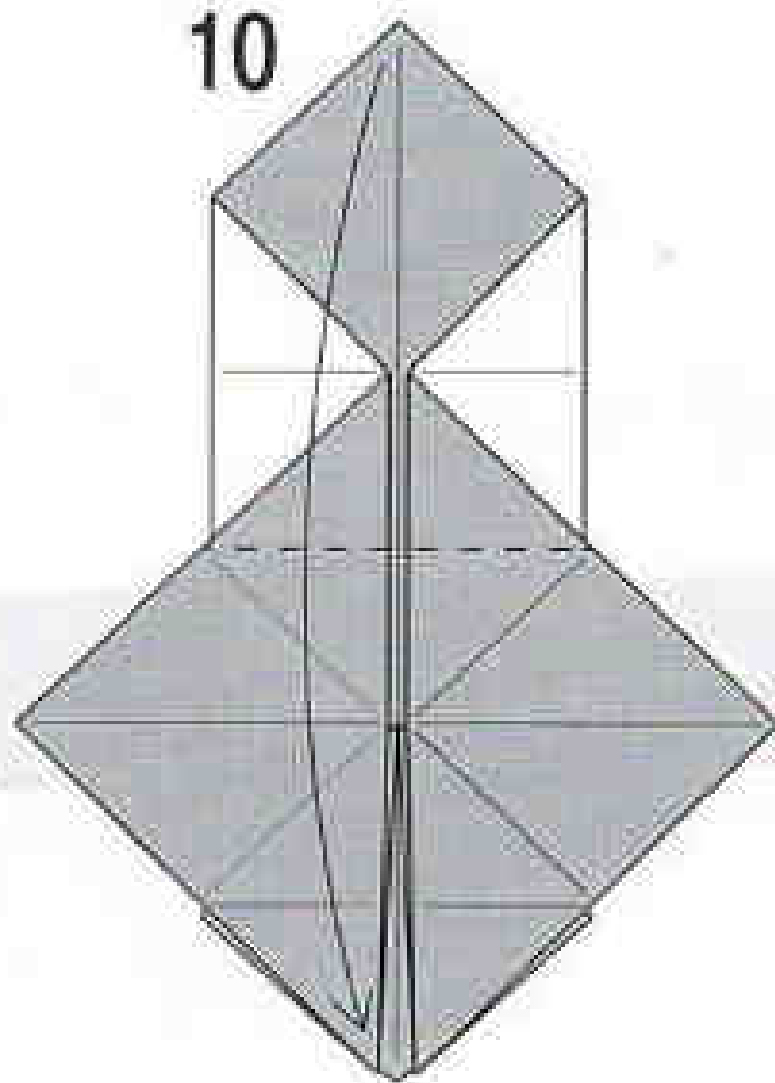

12

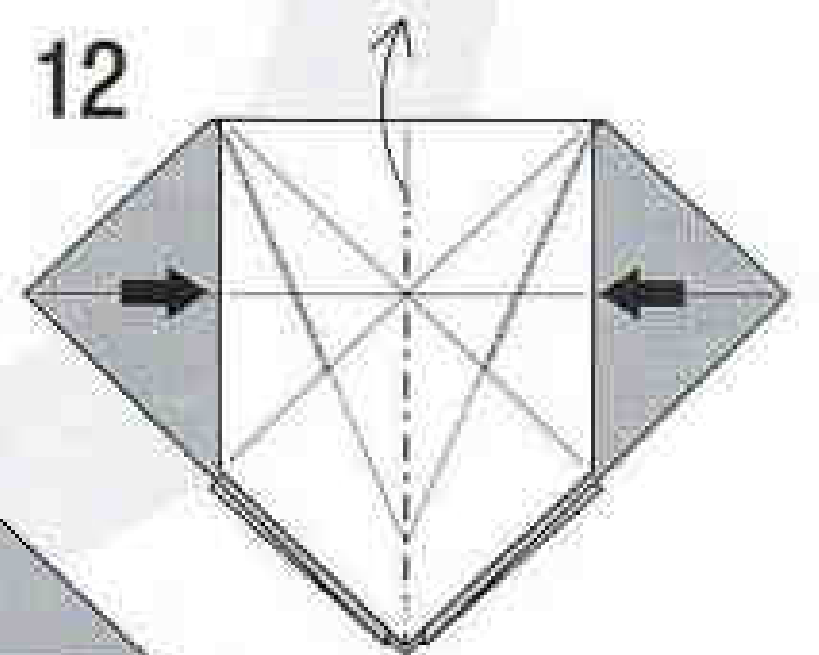

11

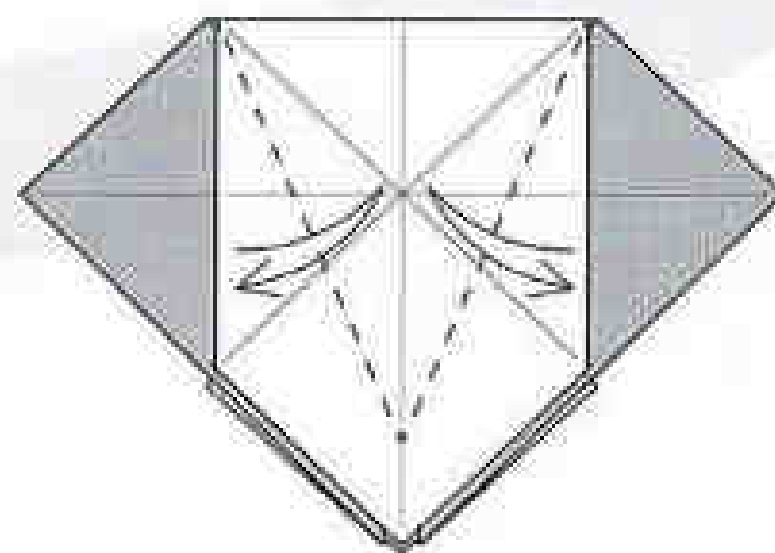

22

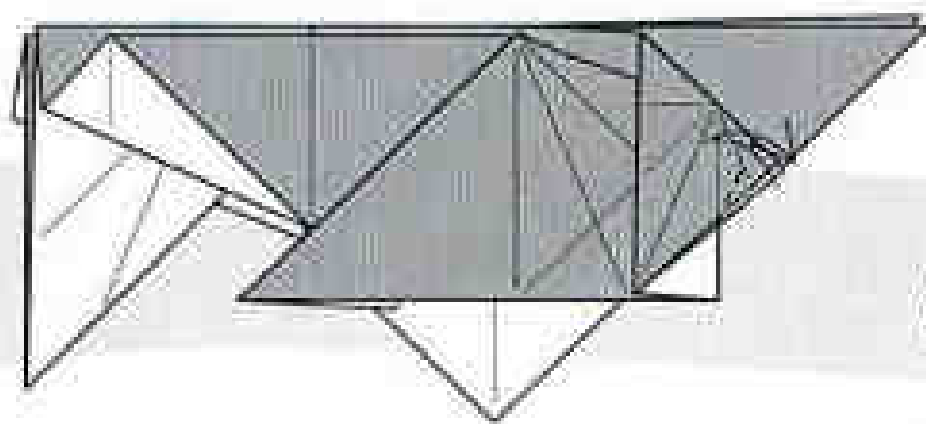

23

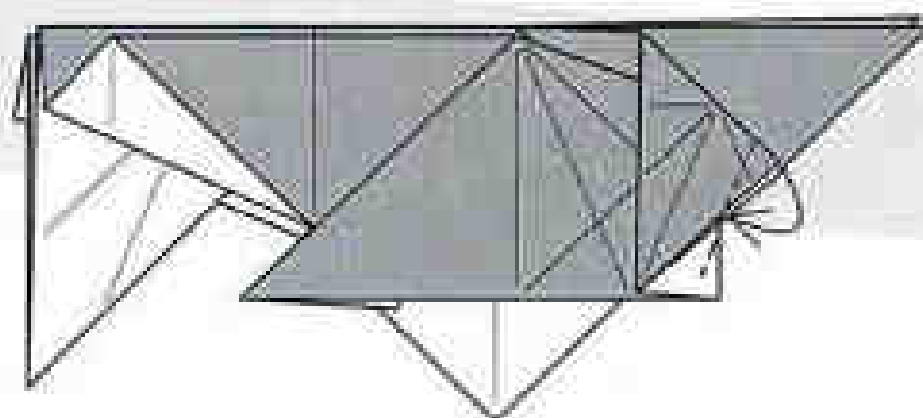

24

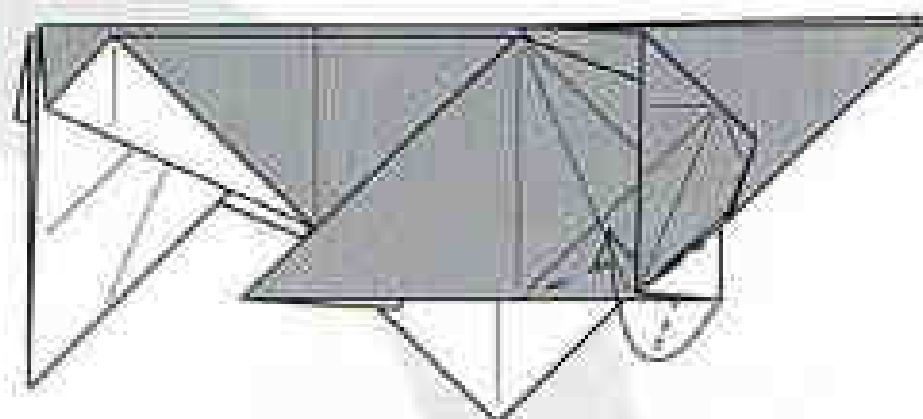

25

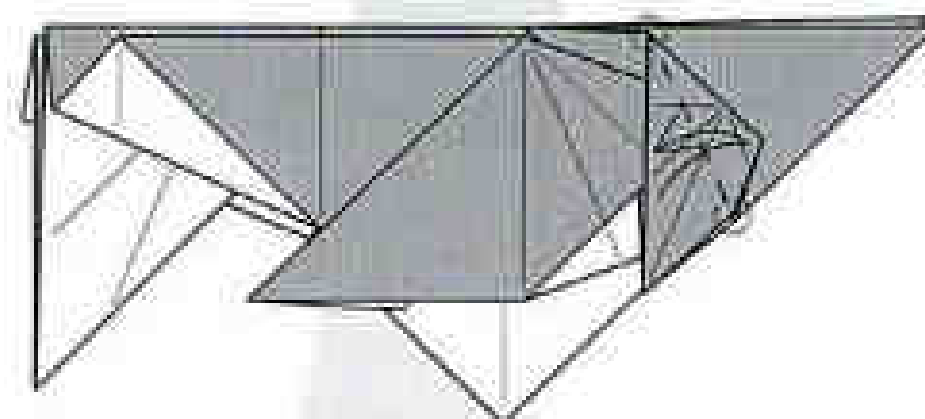

27

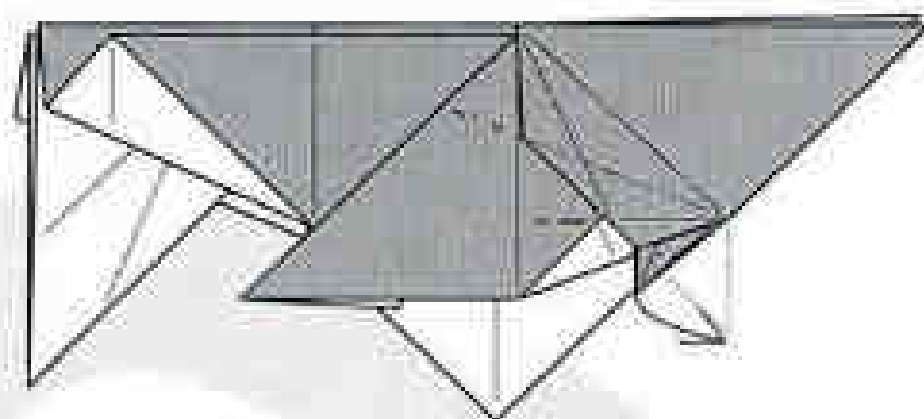

26

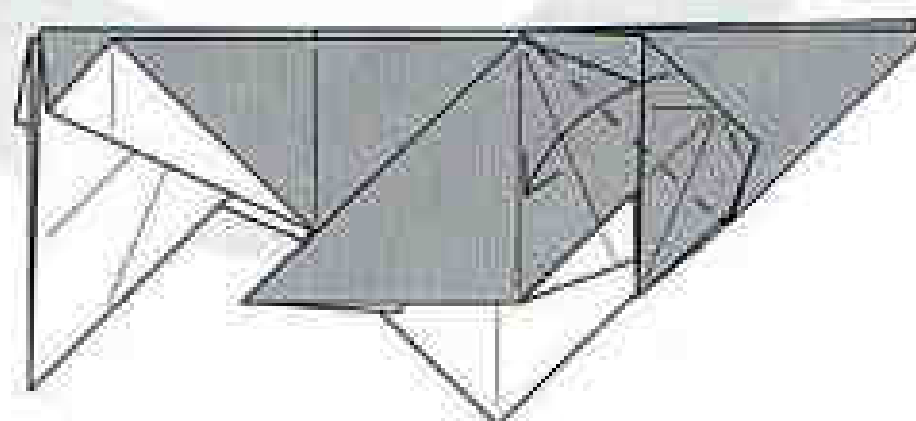

28

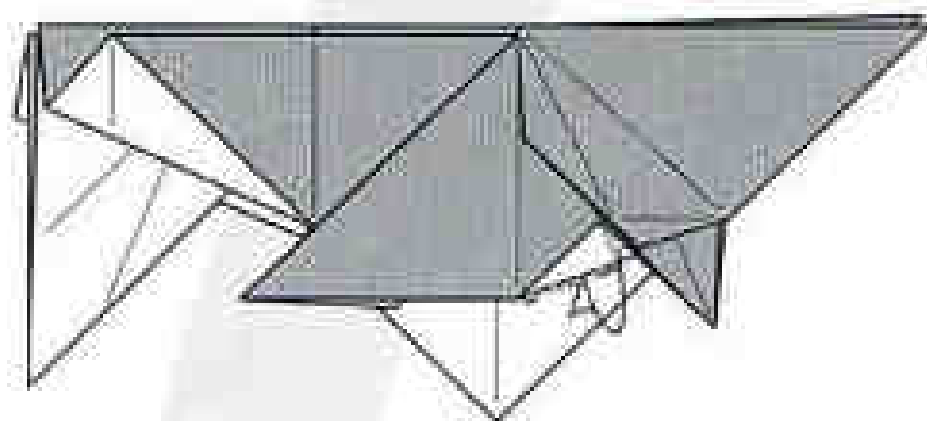

29

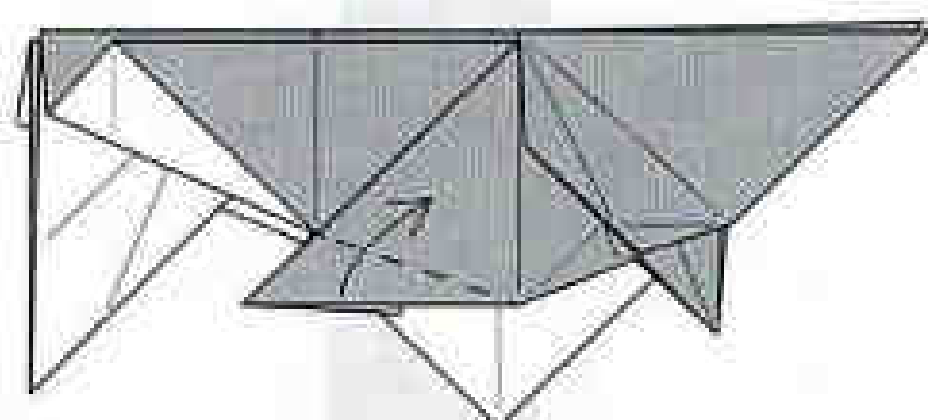

30

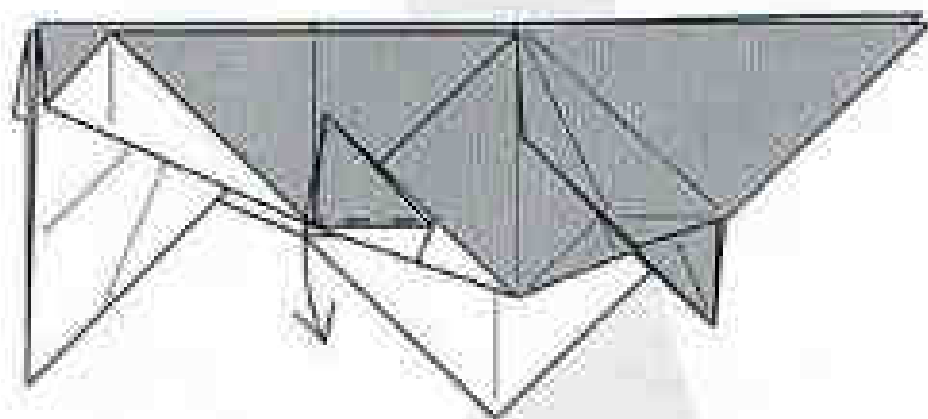

33

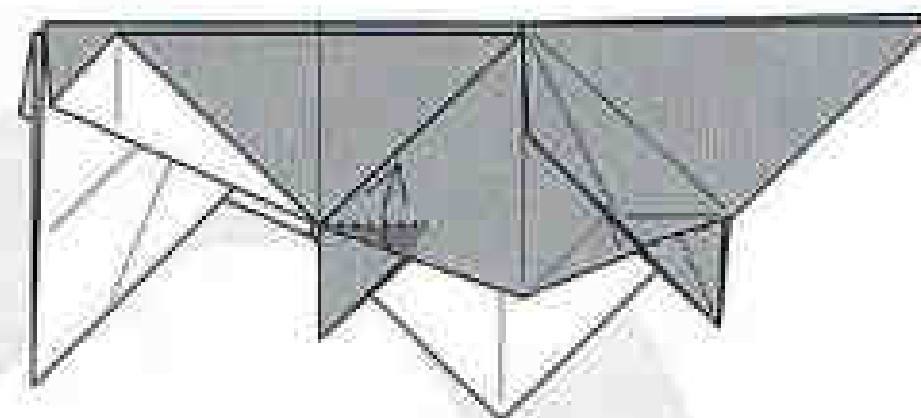

32

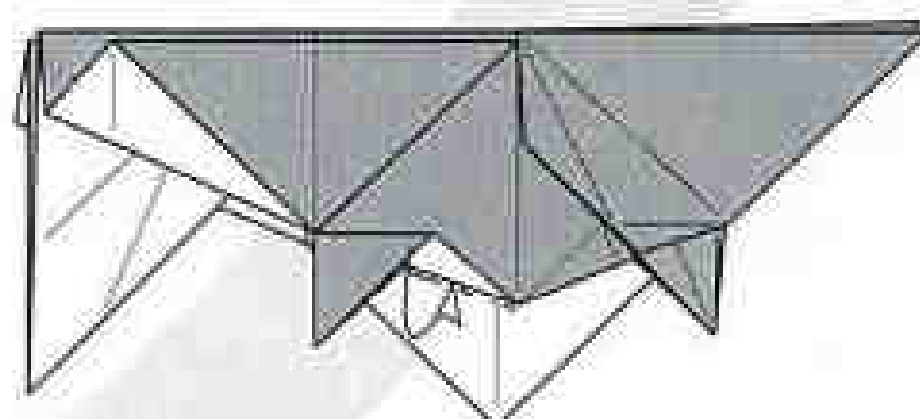

34

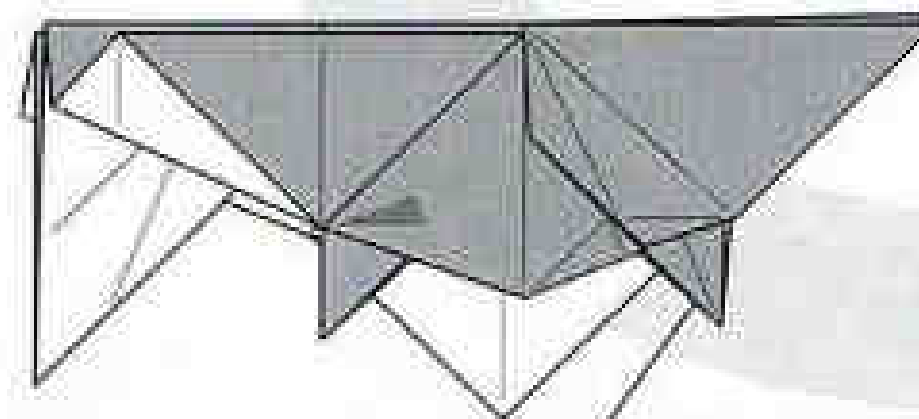

31

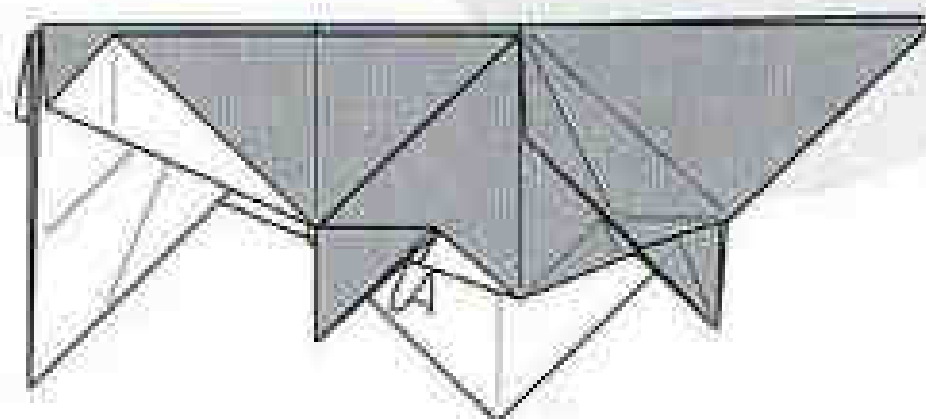

17-33

44

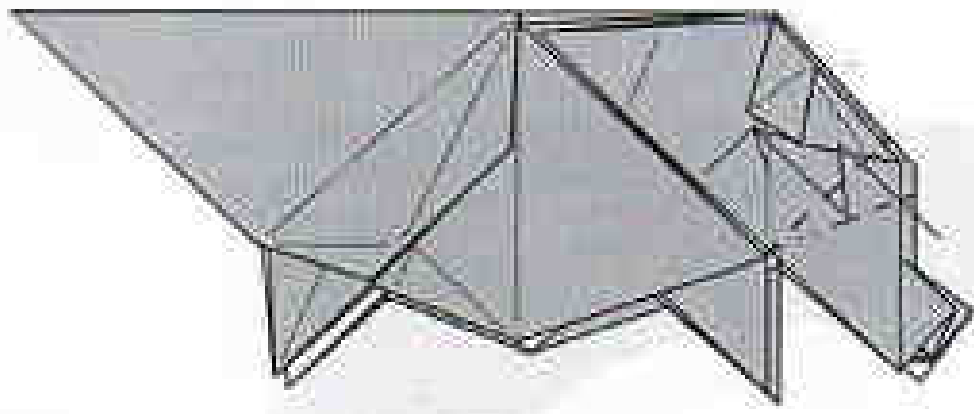

45

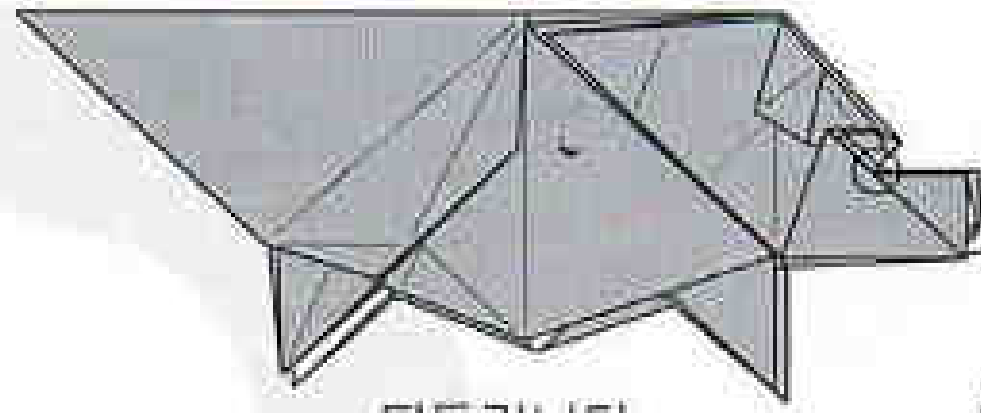

뒤돌립니다.

47

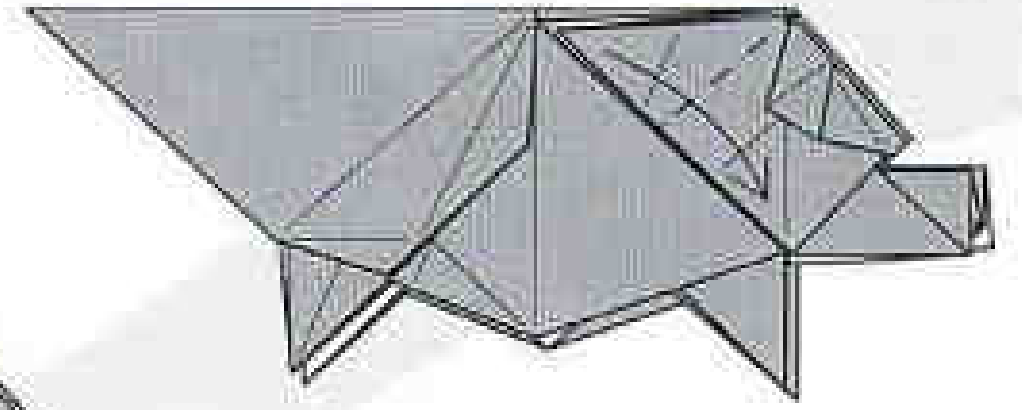

반대쪽도 반복합니다.

43

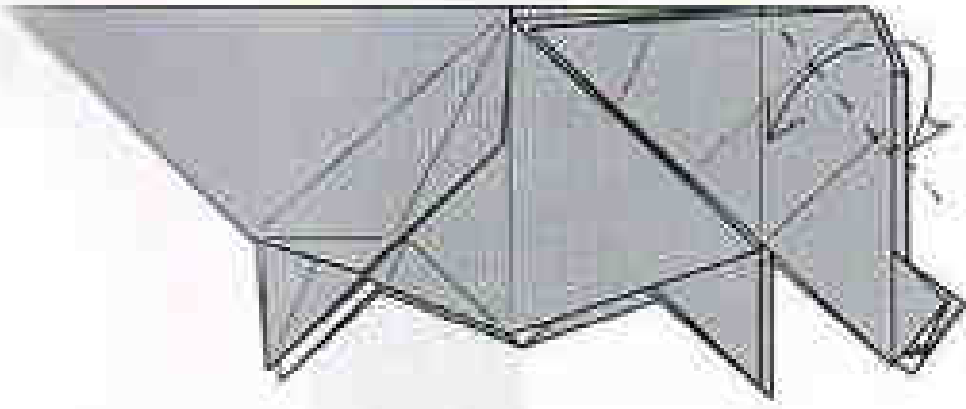

46

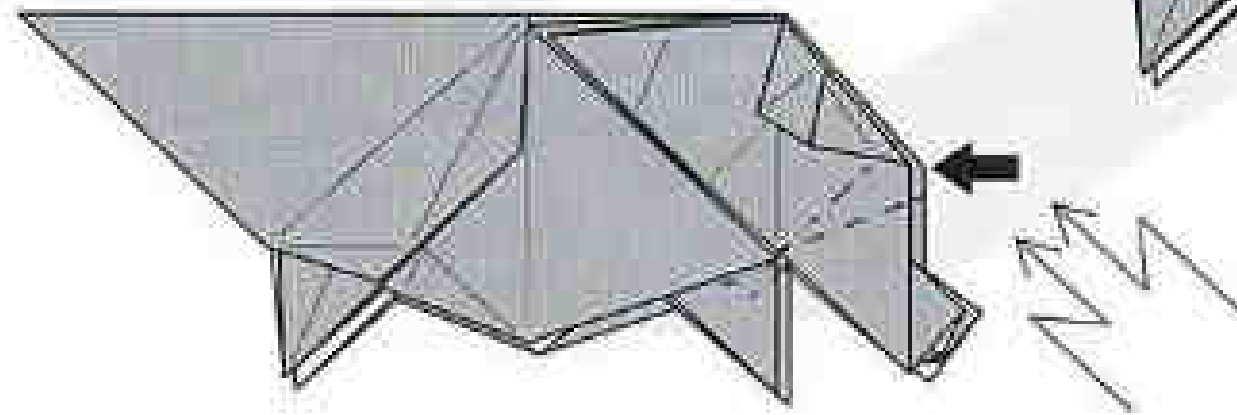

42

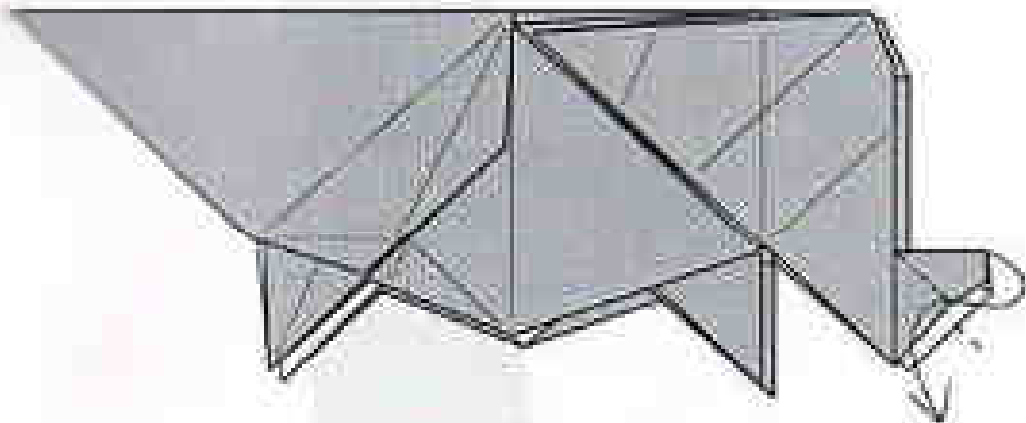

41



39

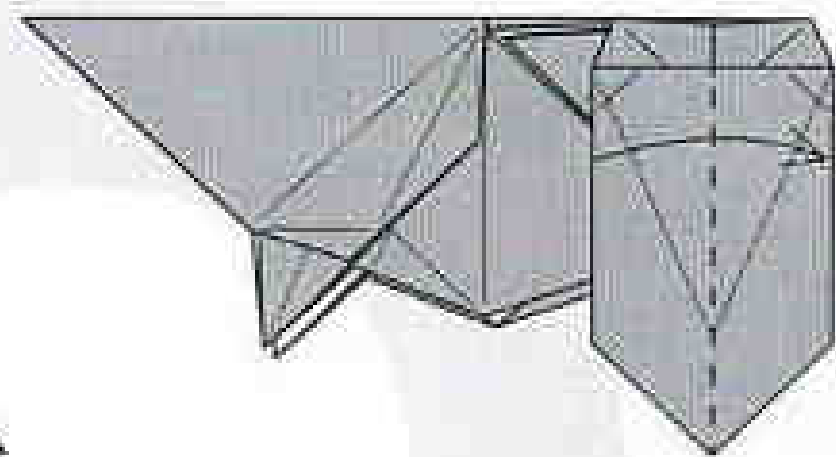

40

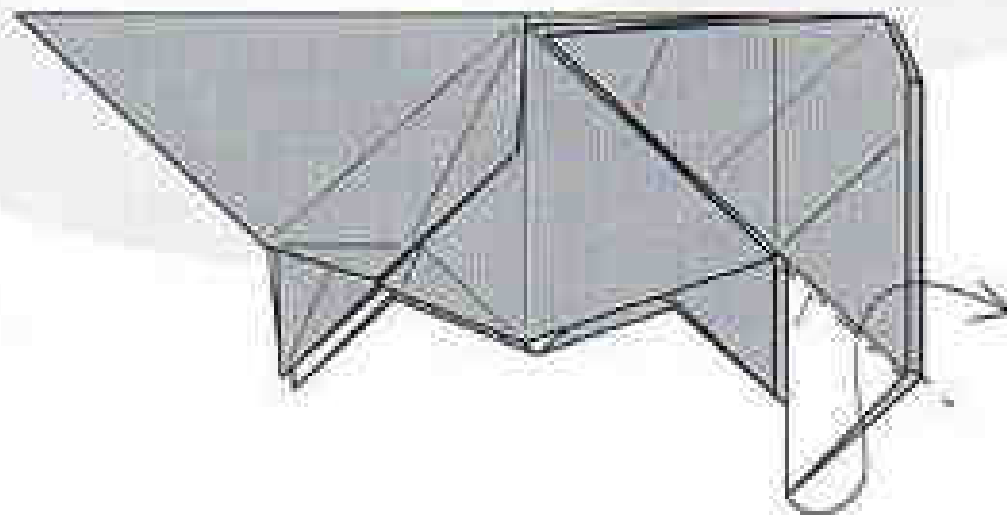

38

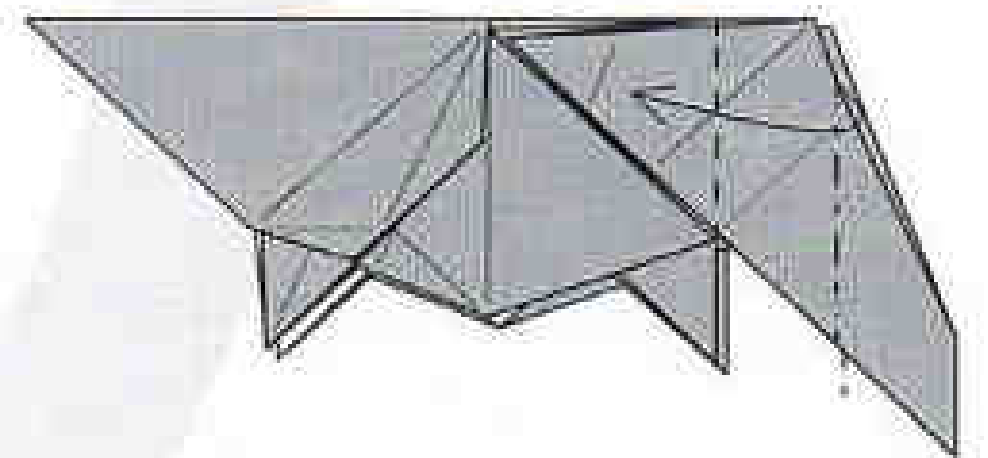

35

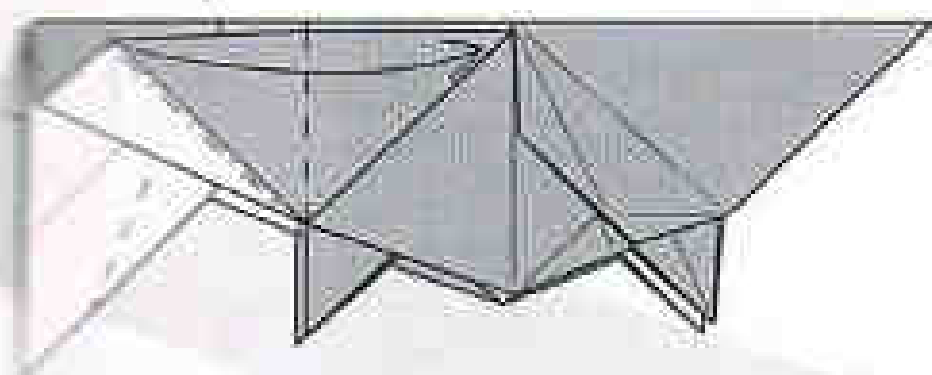

37

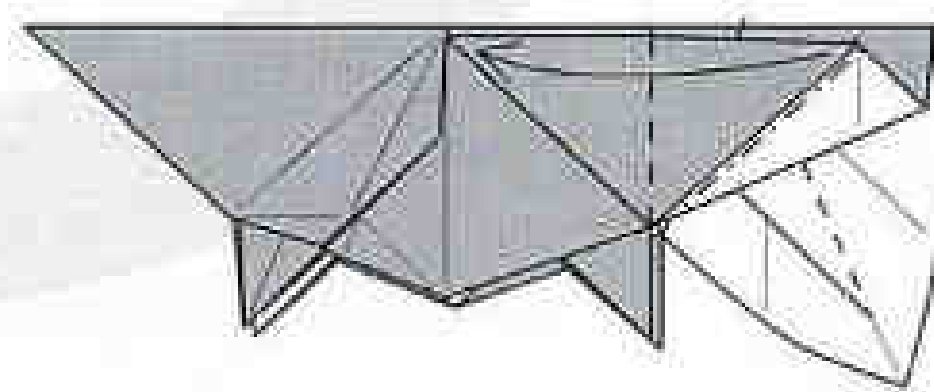

36



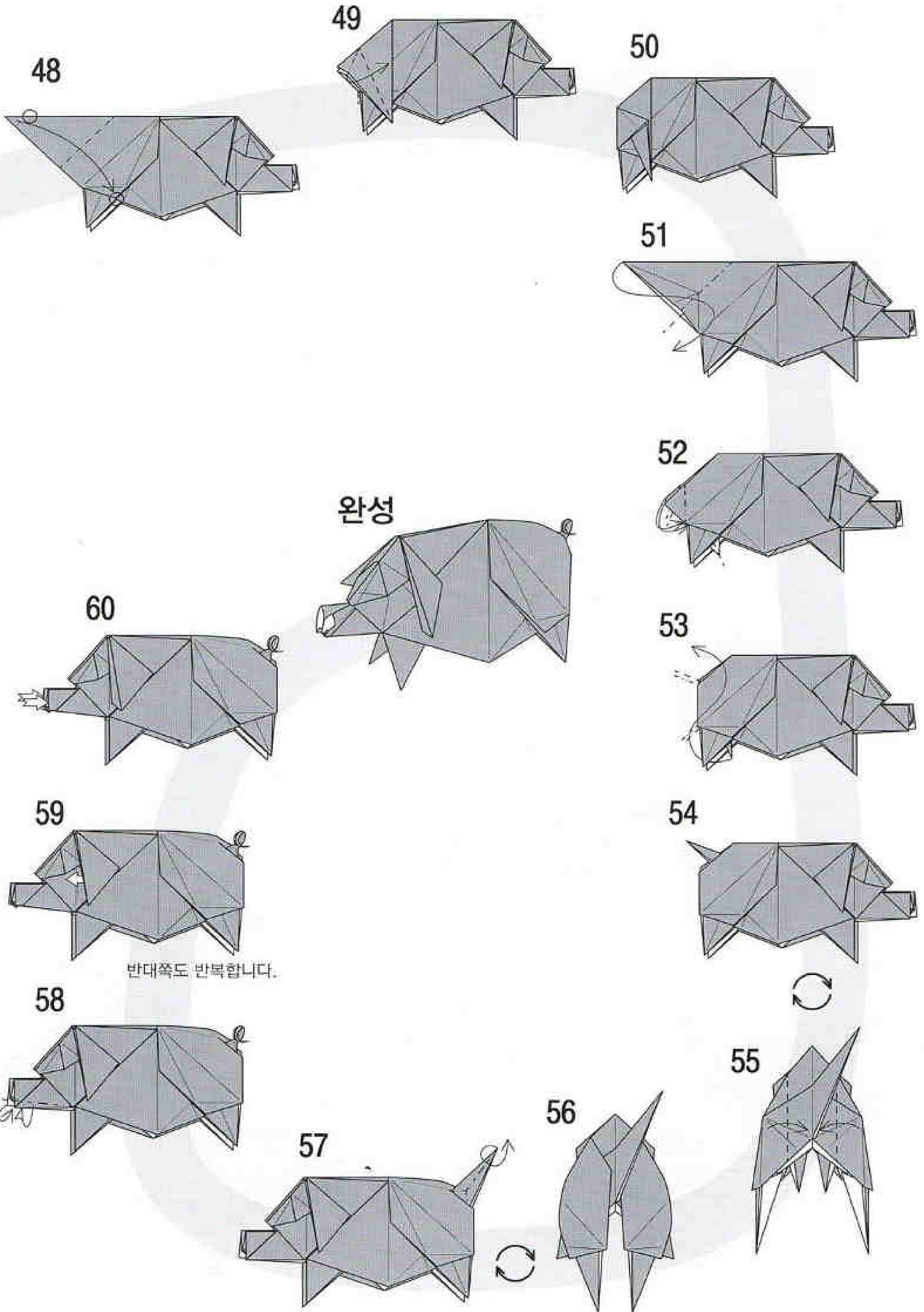

49

50

48

51

완성

52

60

53

59

54

반대쪽도 반복합니다.

58



55

57

56



판다 (Panda)

창작가 : 유태용 (Yoo Tae Yong)

다이어그램 : 유태용 (Yoo Tae Yong)

창작일 : 2015.06.28

종이크기 : 20cm x 20cm

몸통 부분은 쉽게 창작이 가능했지만, 얼굴에서 많은 고민을 하였습니다.
 얼굴 부분이 갈라지는 것과 얼굴의 형태가 판다같지 않았기 때문에 나름대로 자연스럽게 마무리하려 노력했지만 접는 이에 따라 형태가 부자연스러울 수 있는 부분이 아쉽습니다.

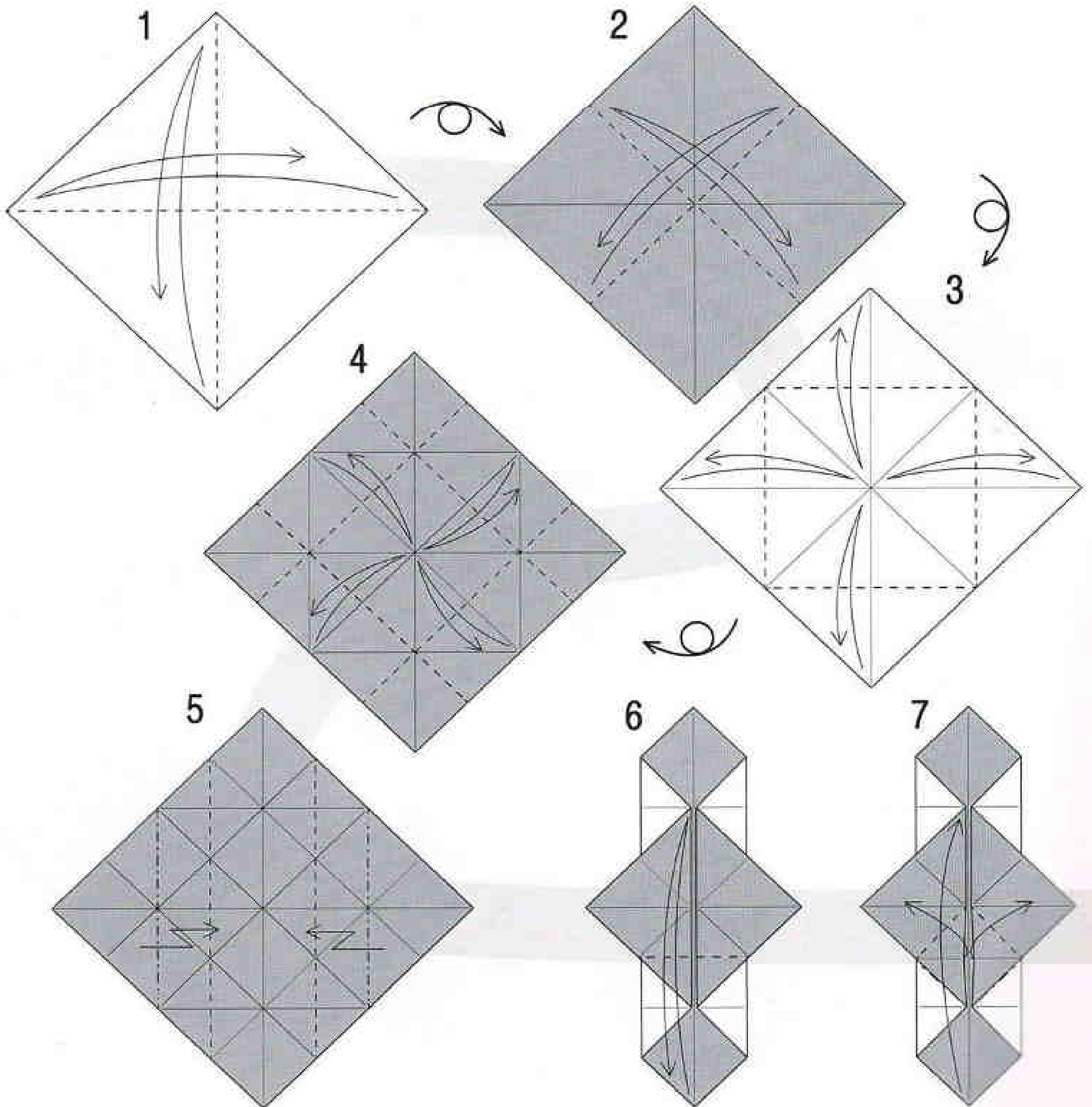
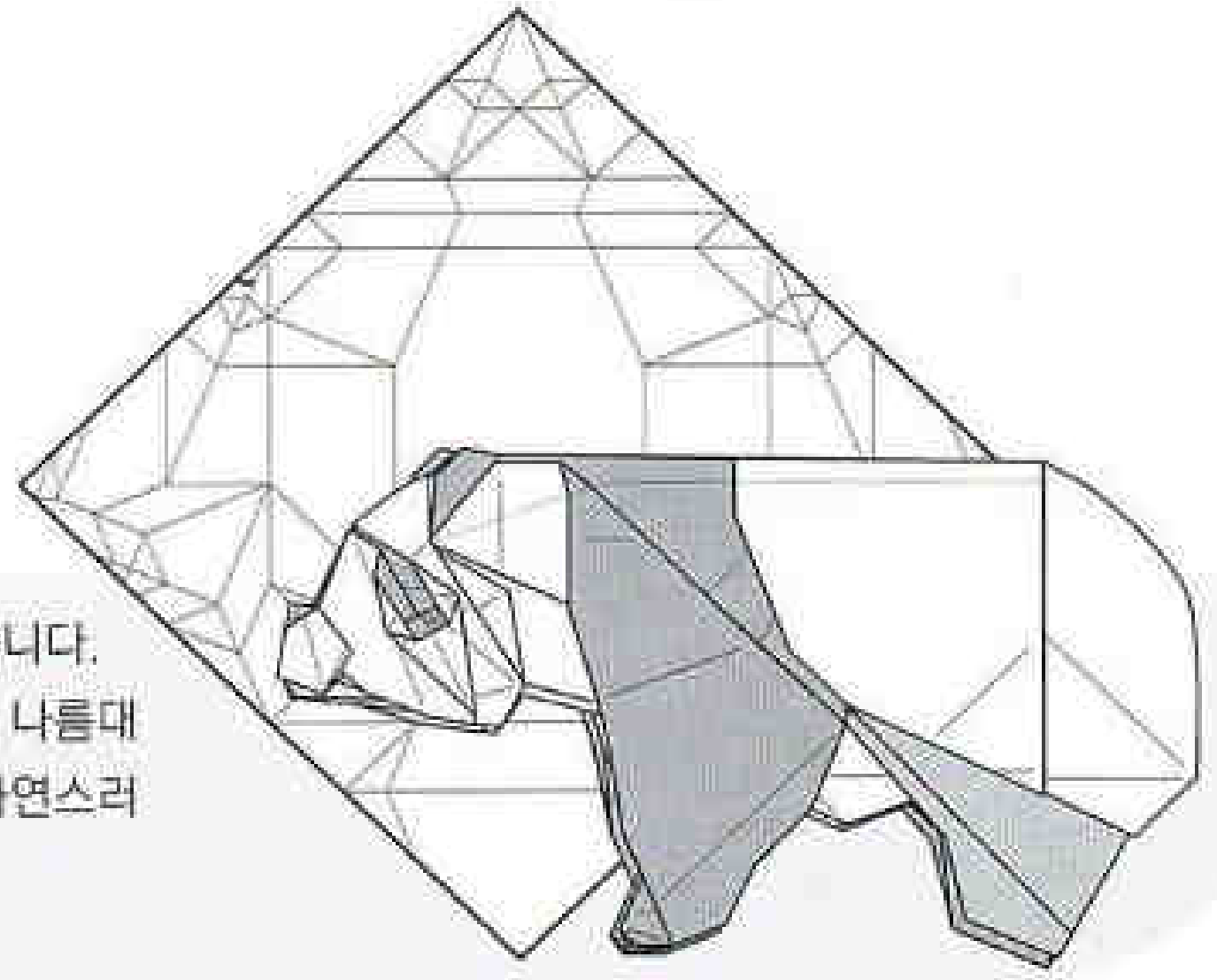

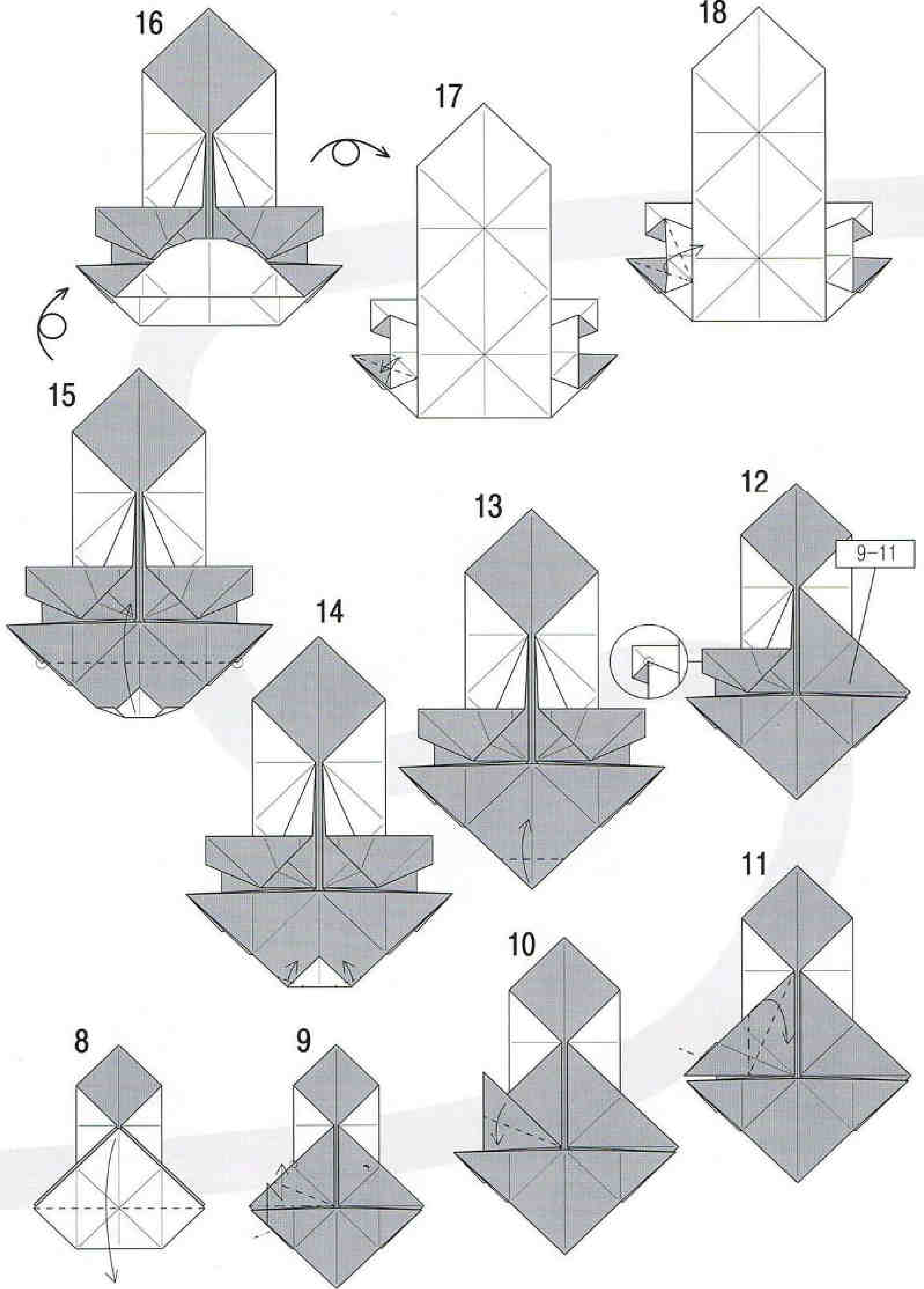

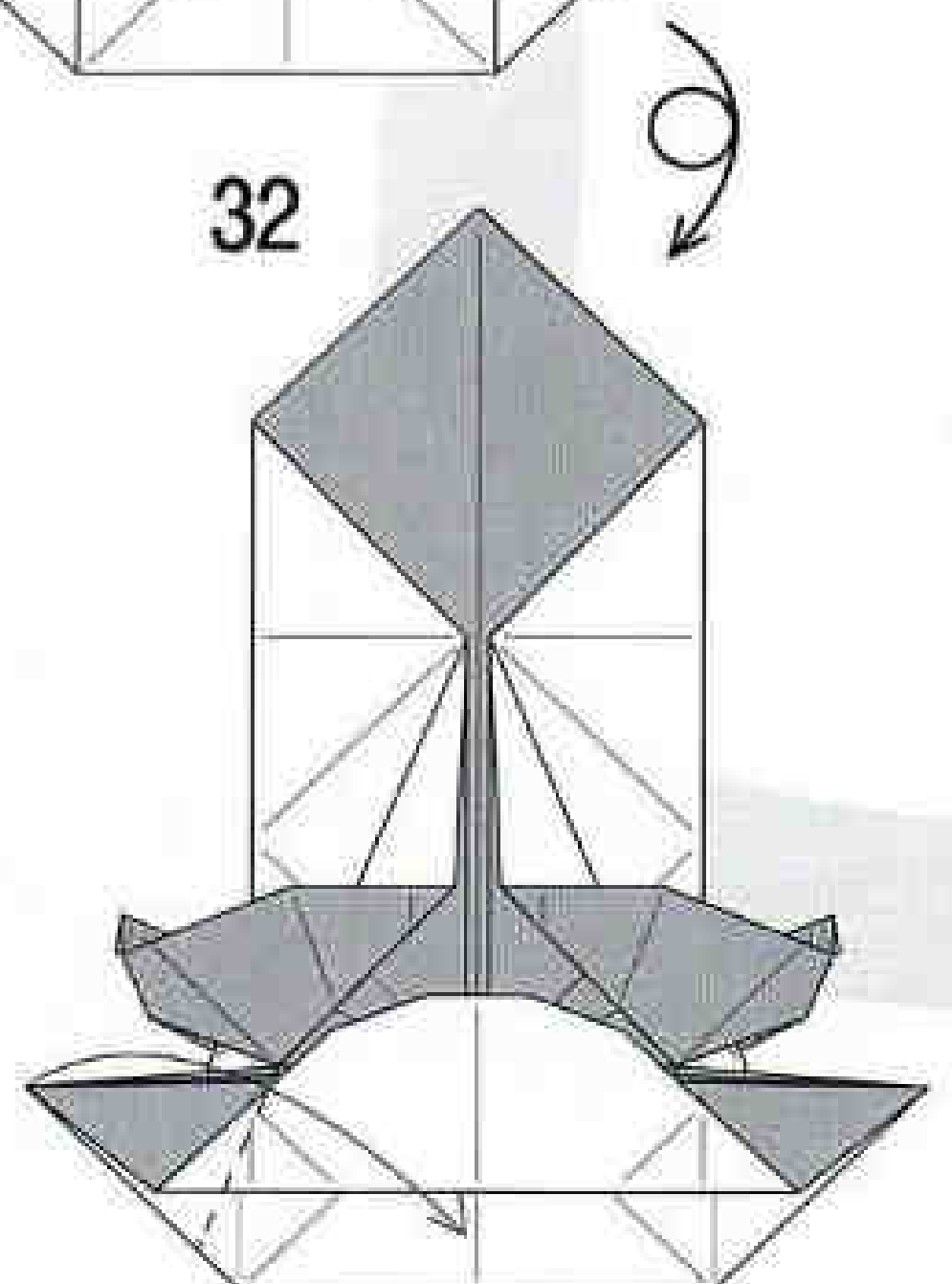
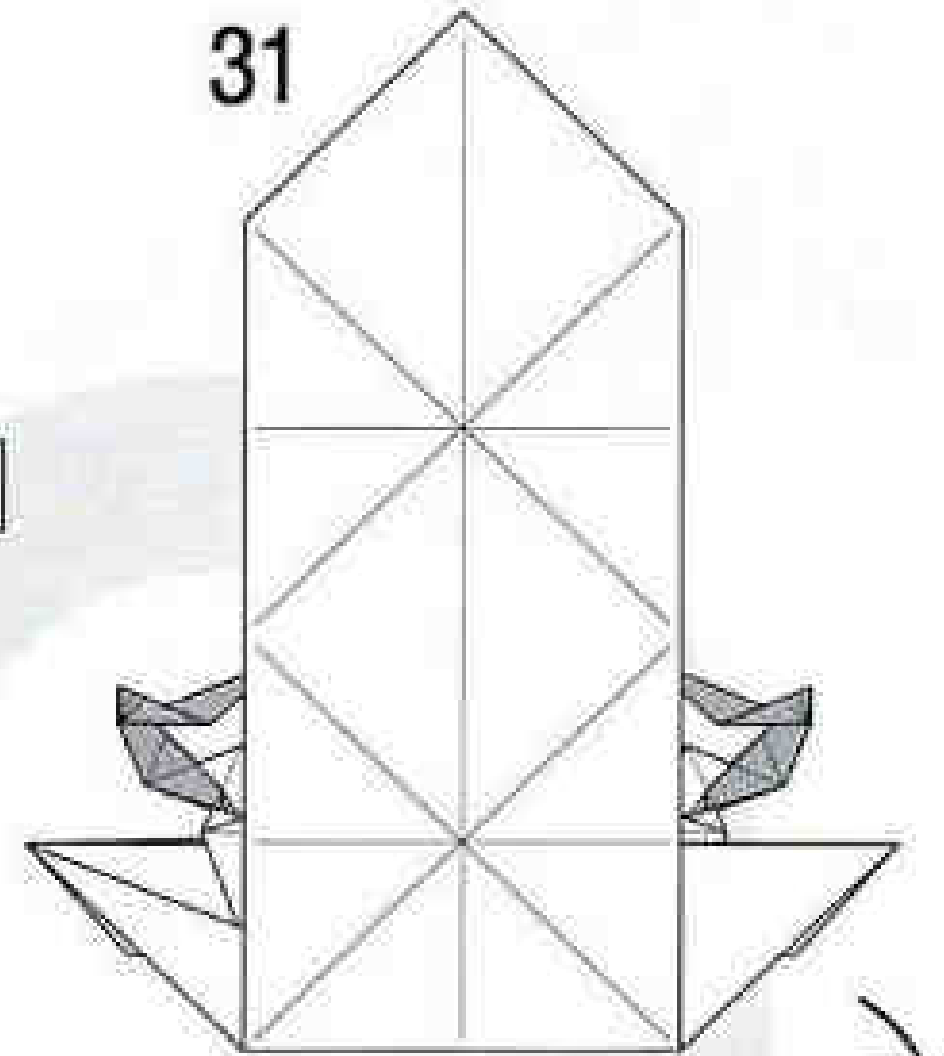
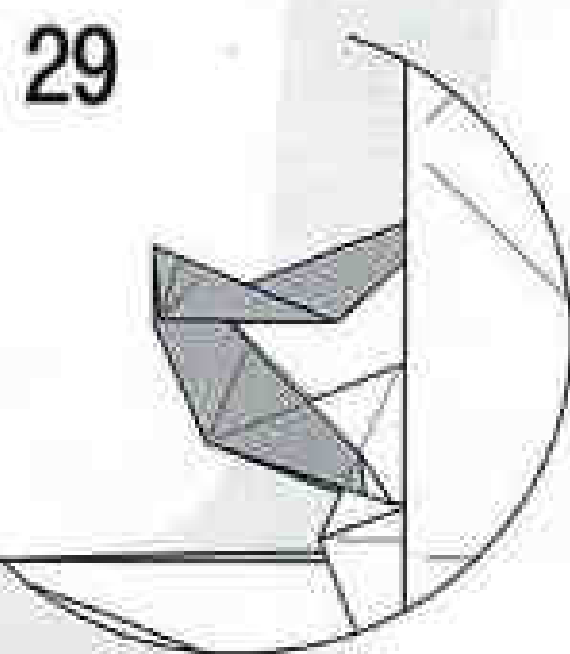
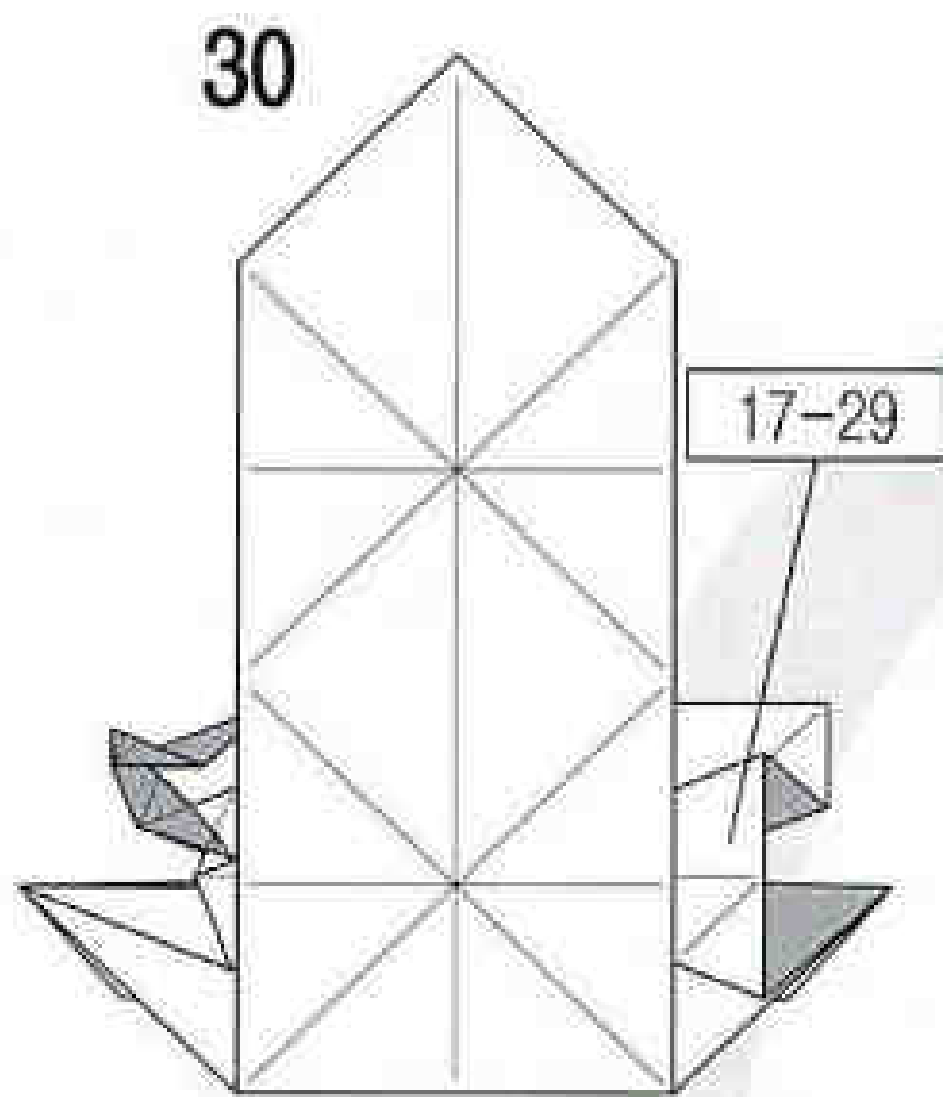
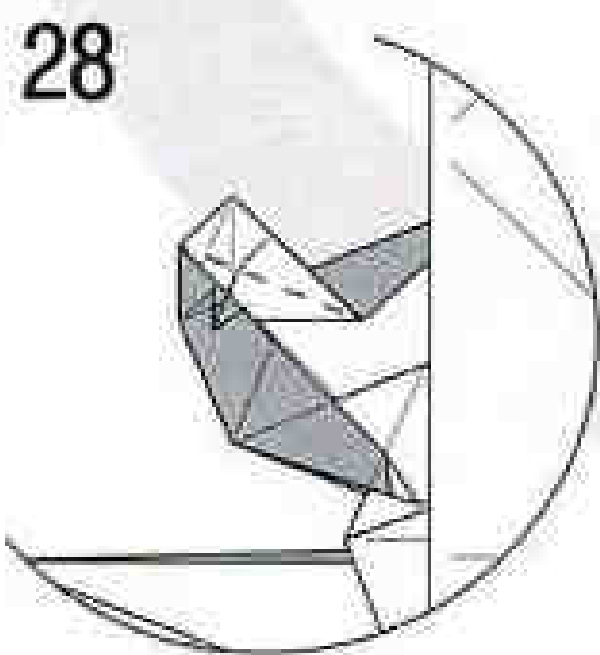
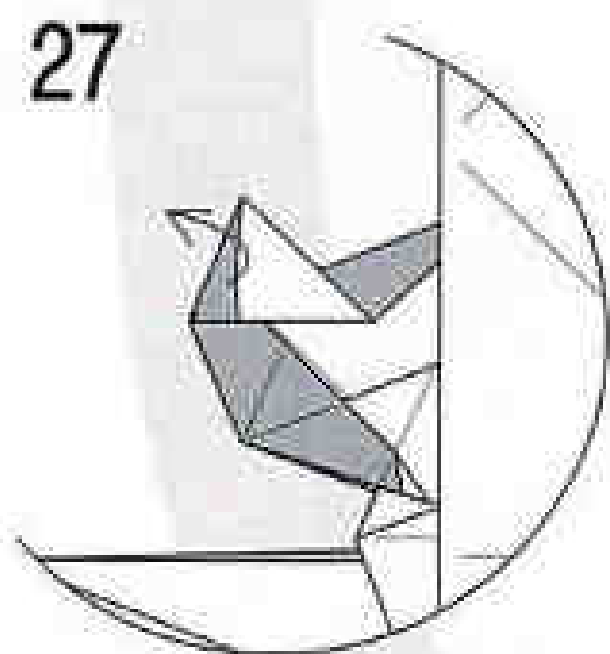
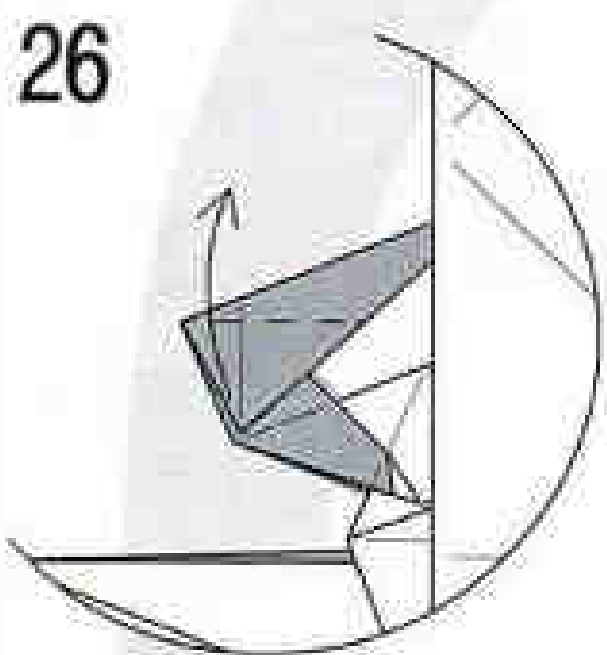
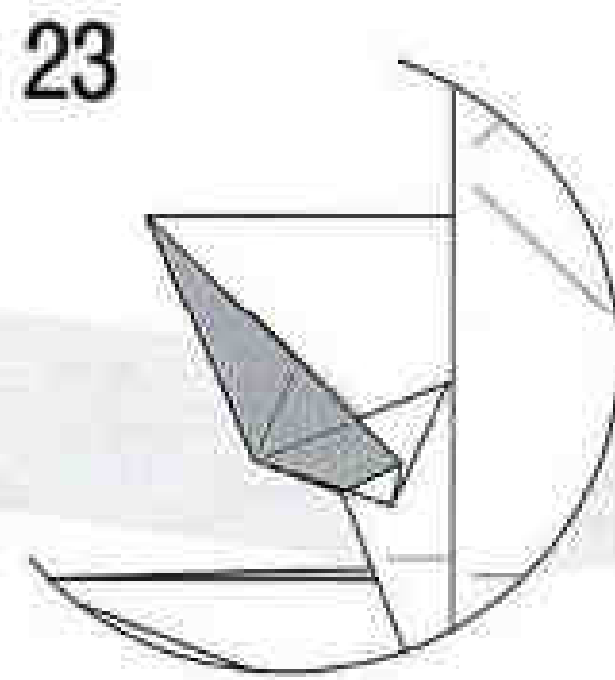
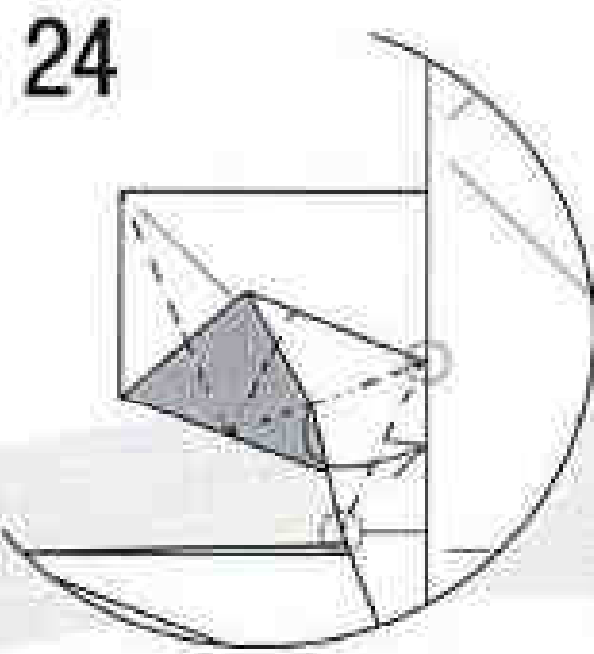
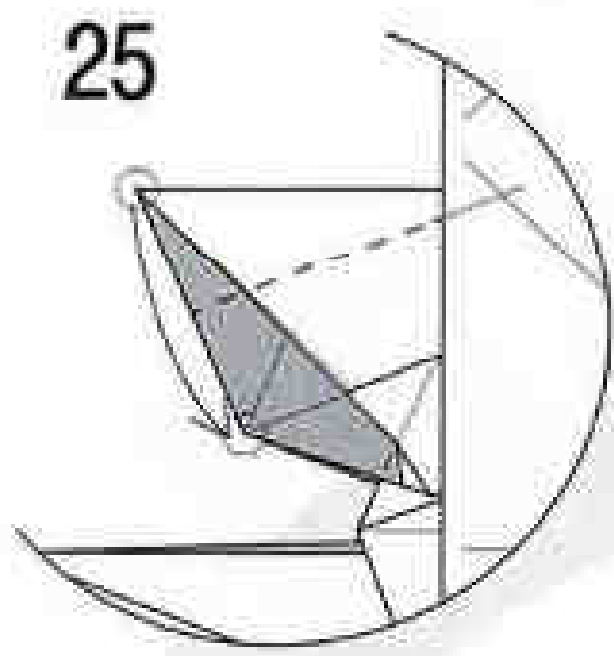
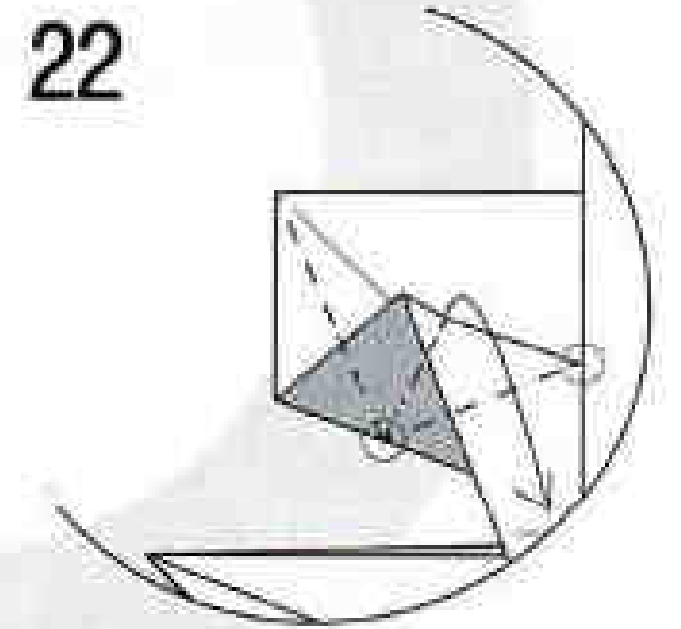
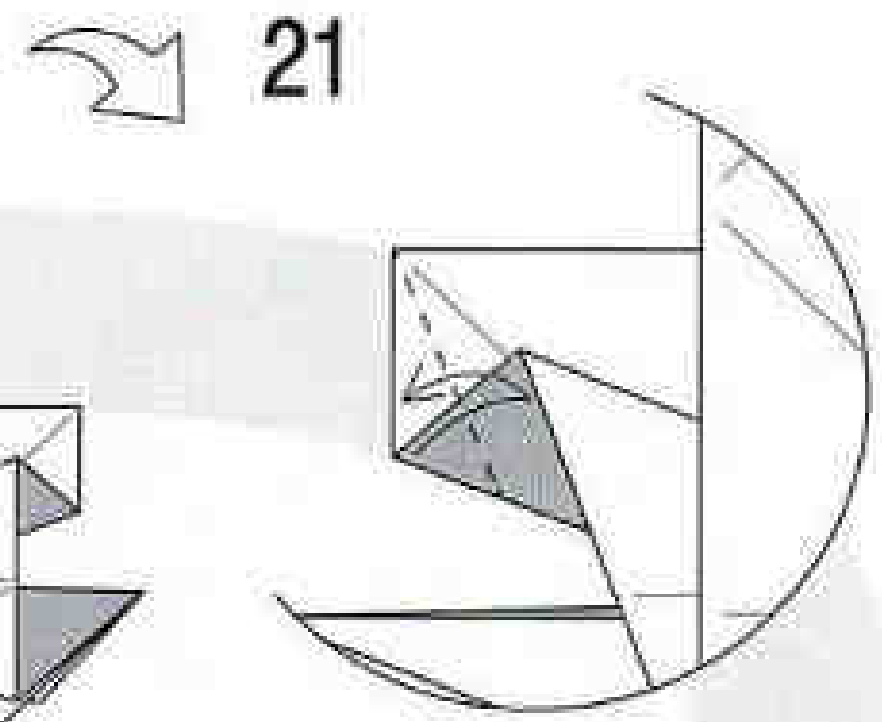
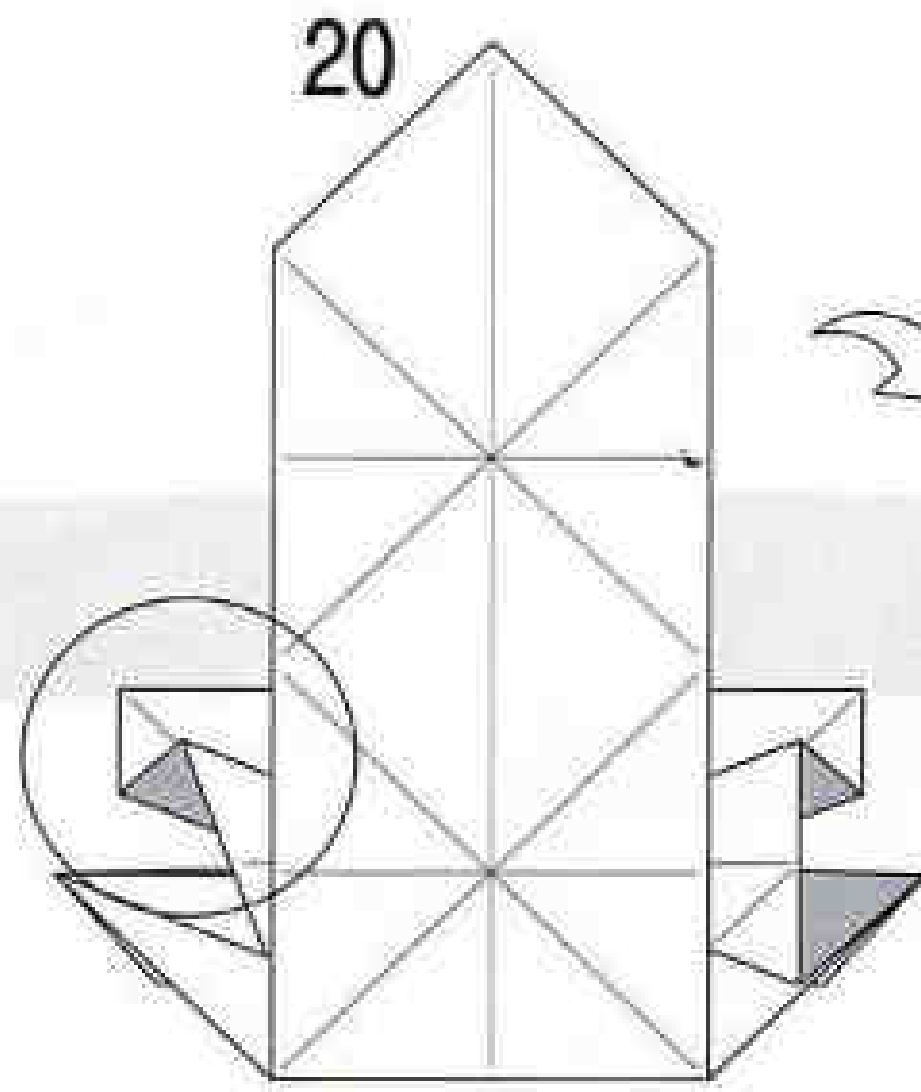
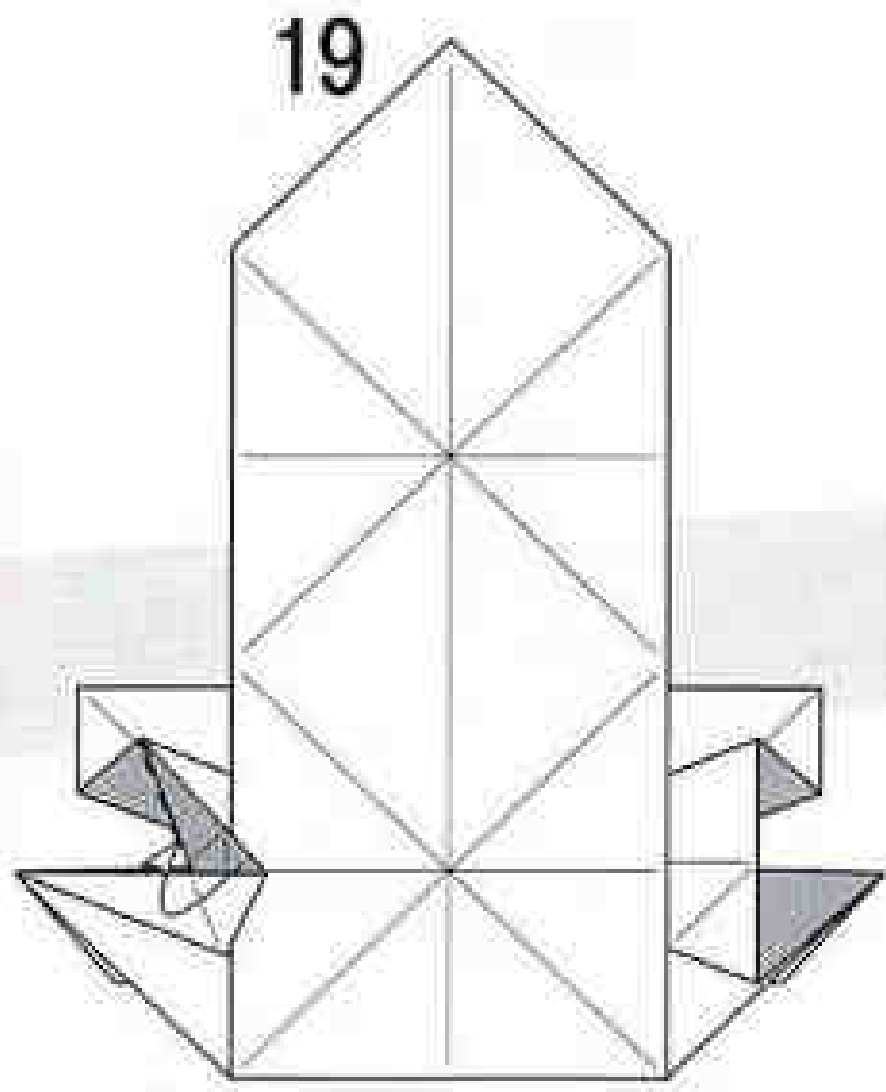

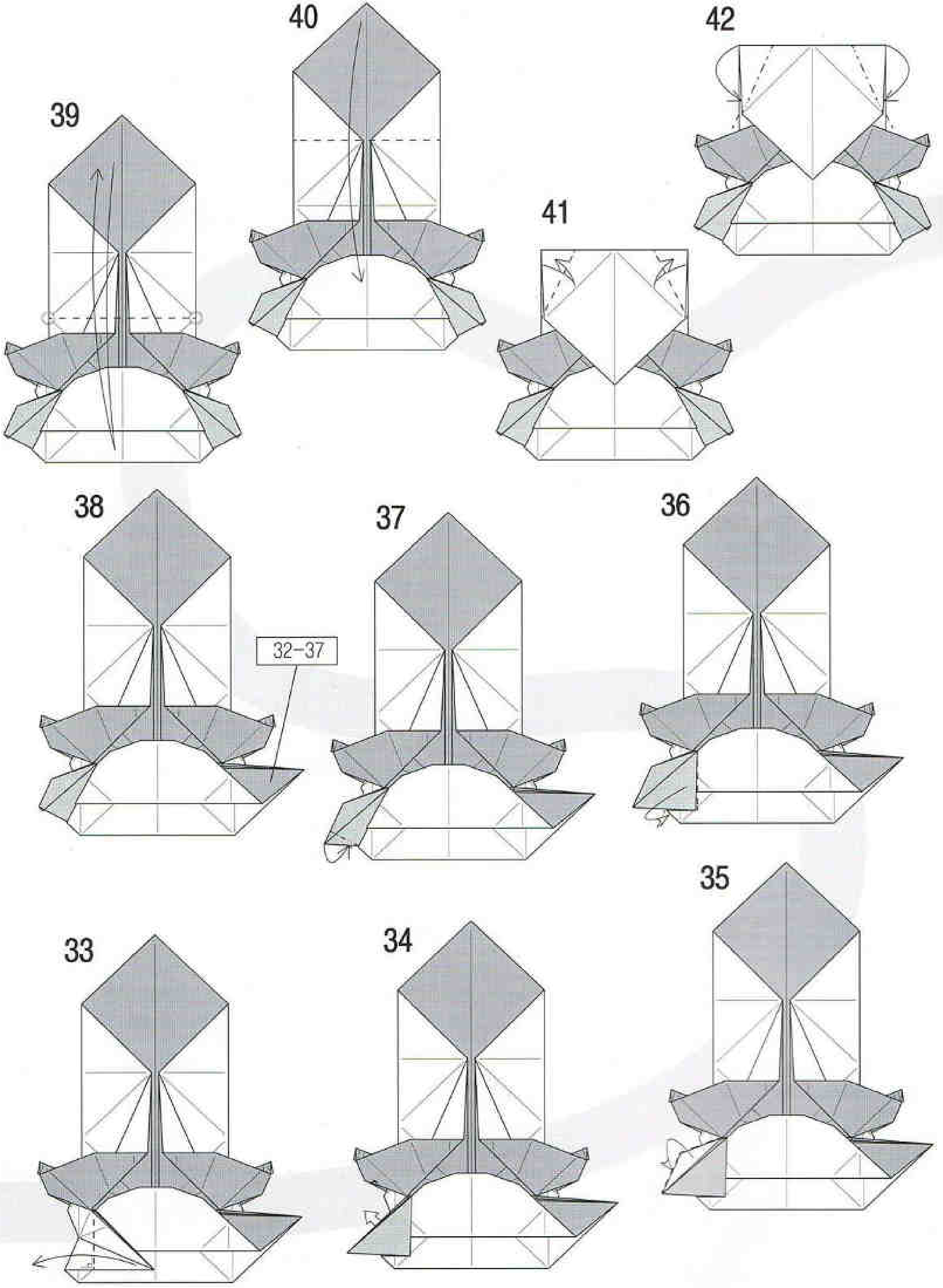

40

42

39

41

38

37

36

32-37

33

34

35

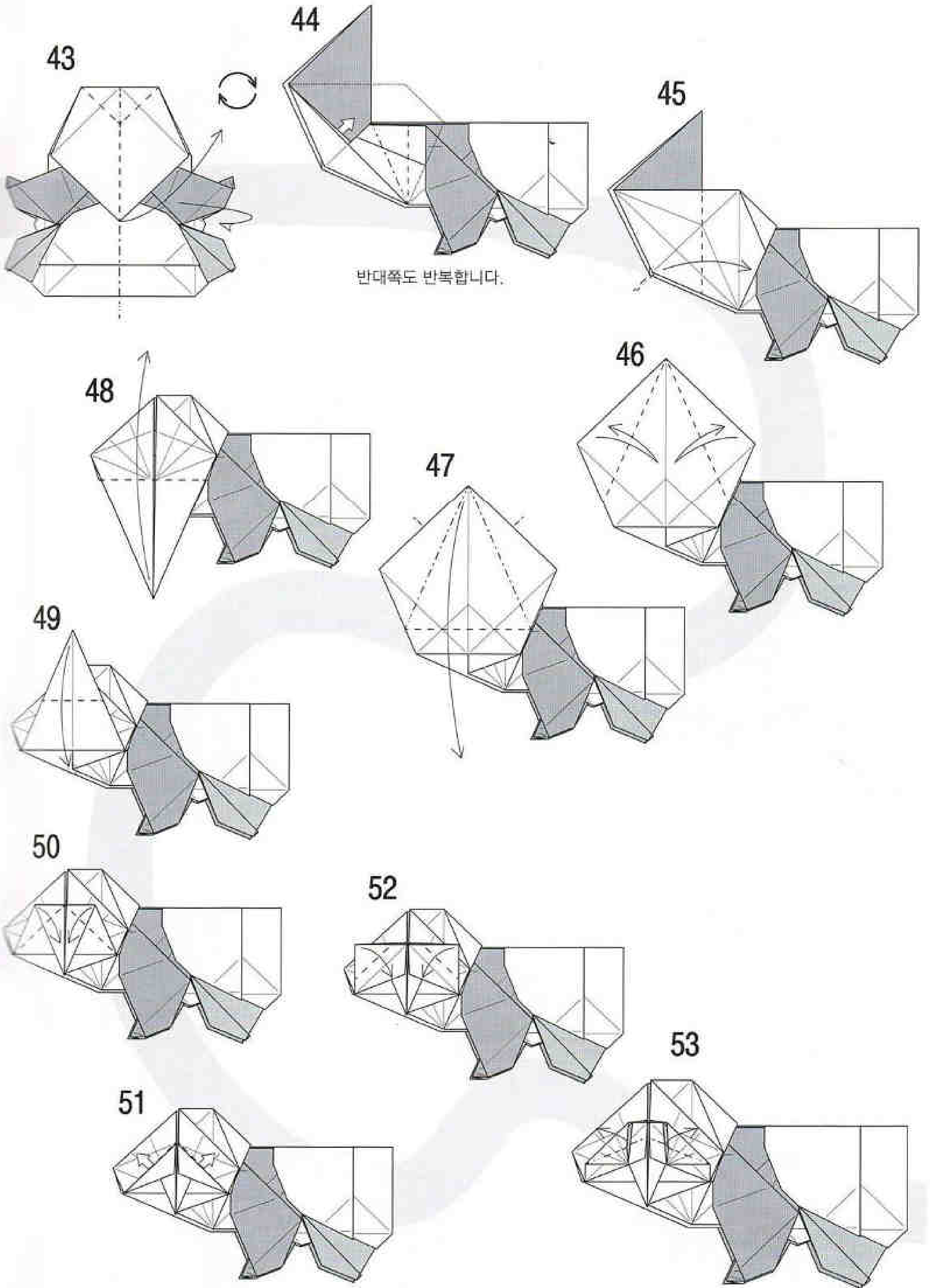

반대쪽도 반복합니다.

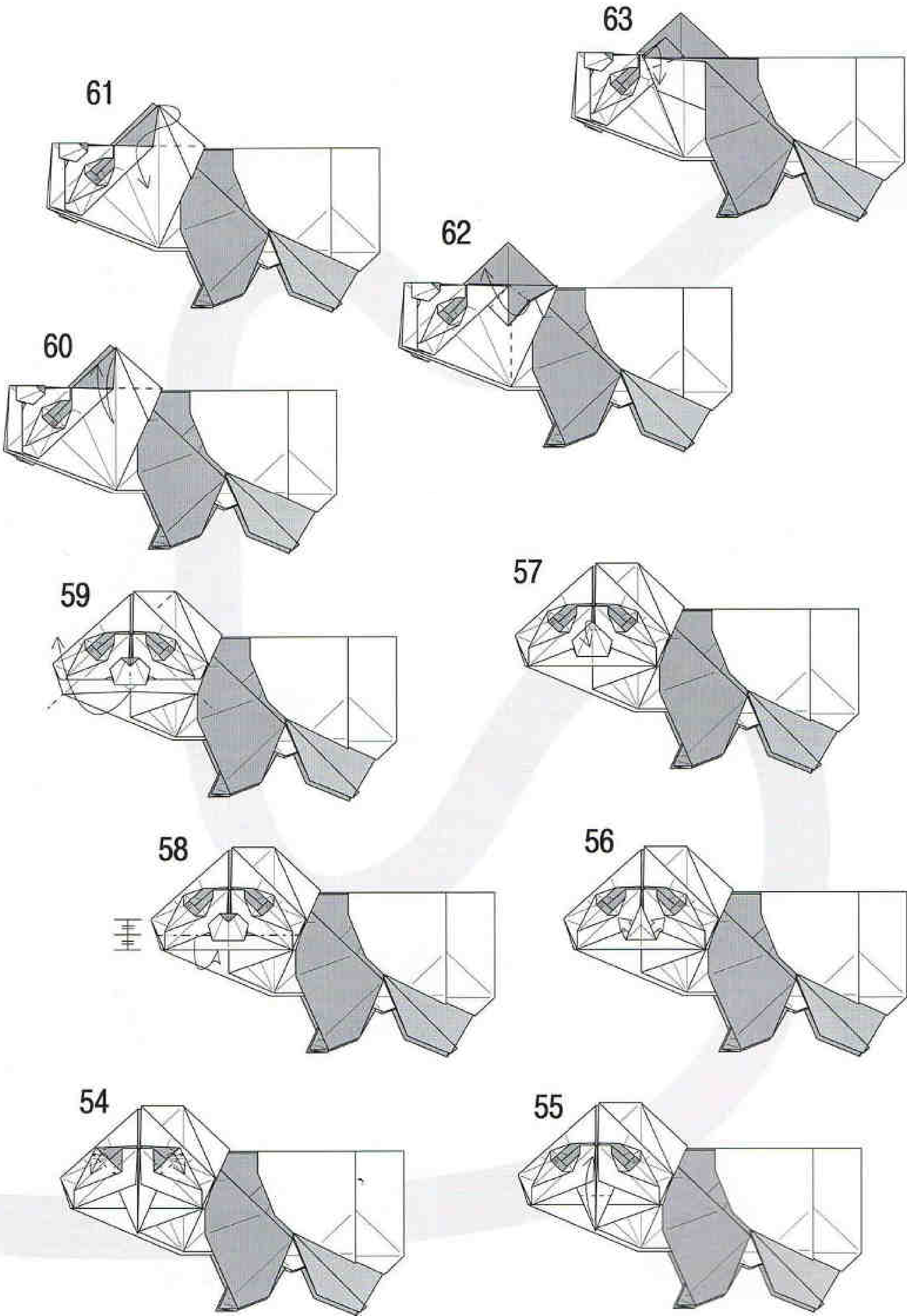

64

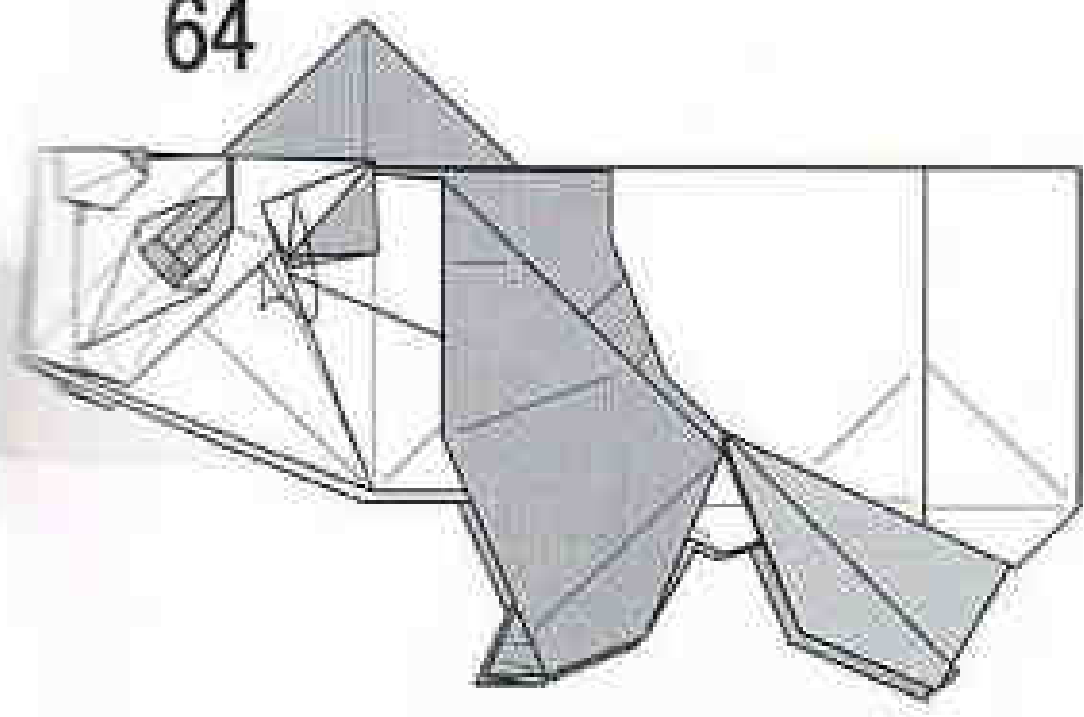

65

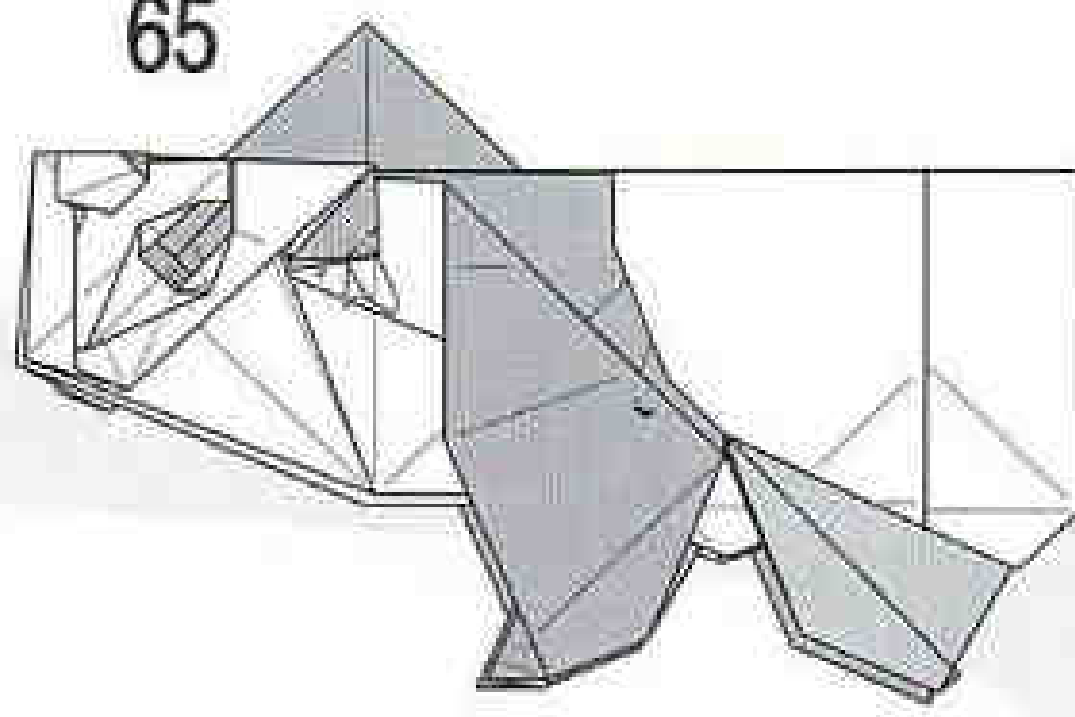

60-65

66

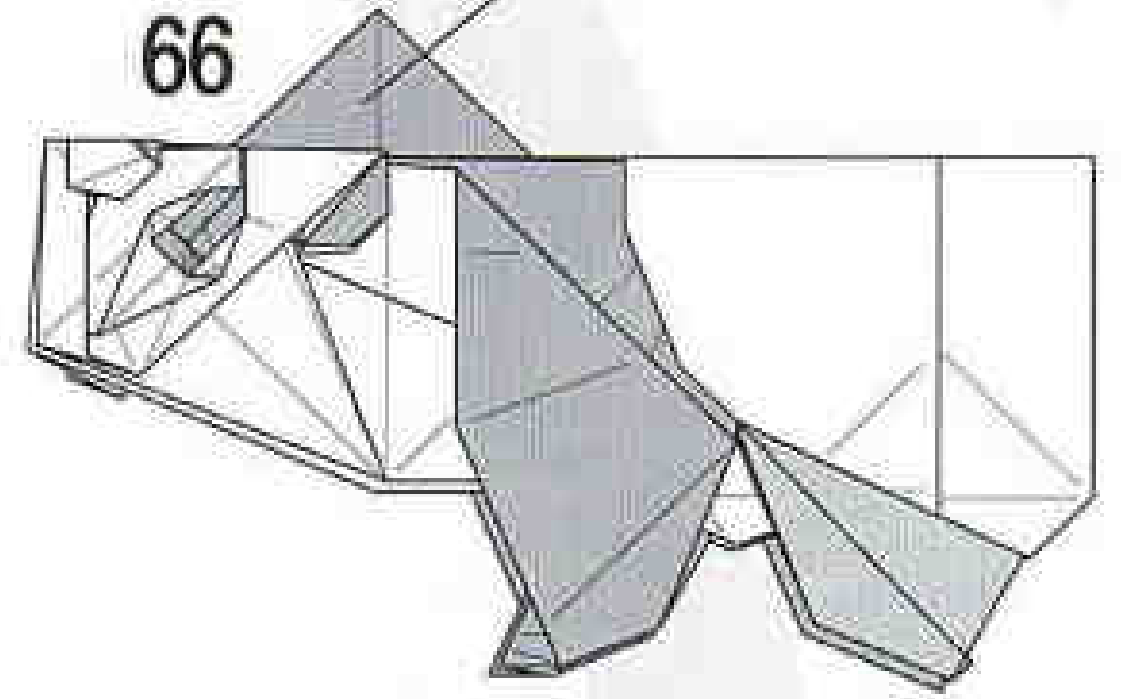

완성

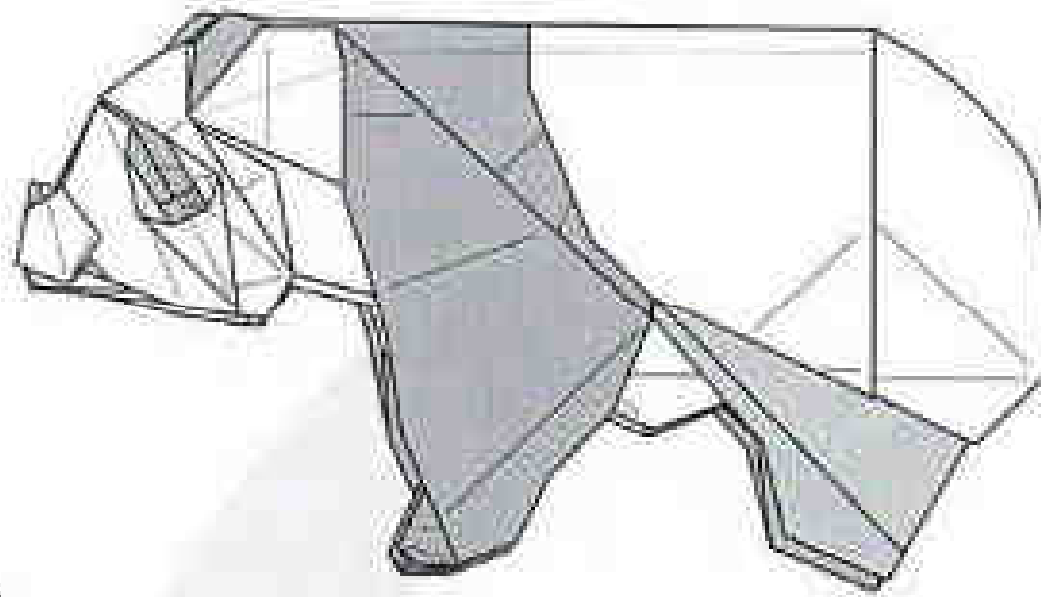

67

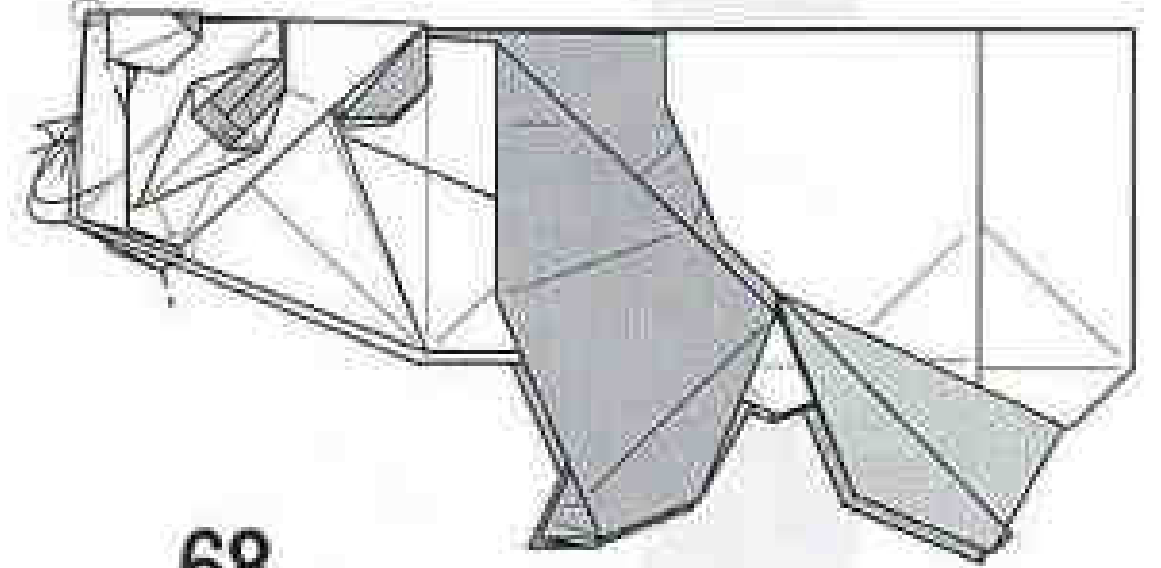

74

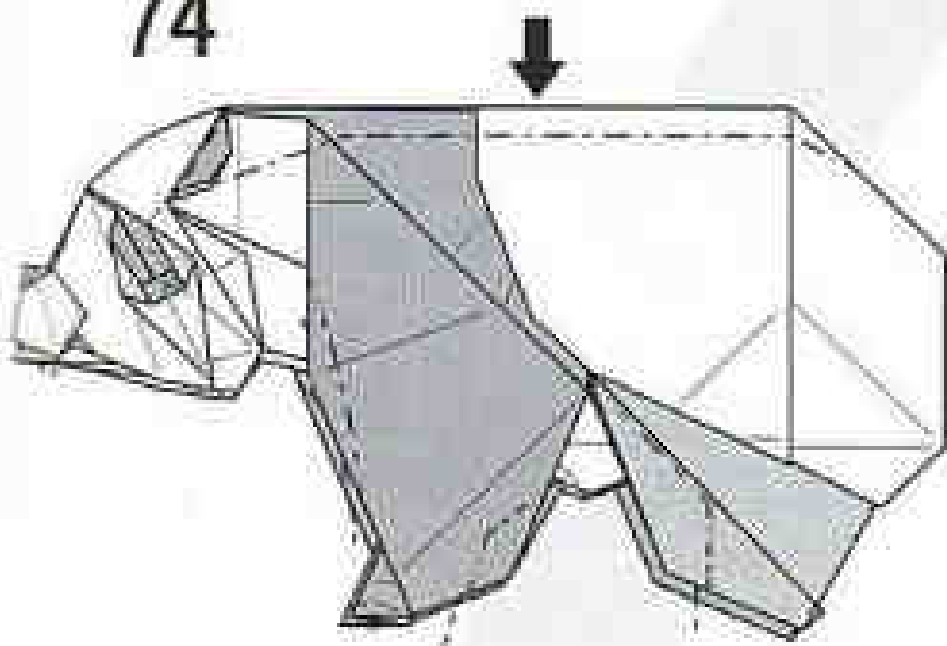

68

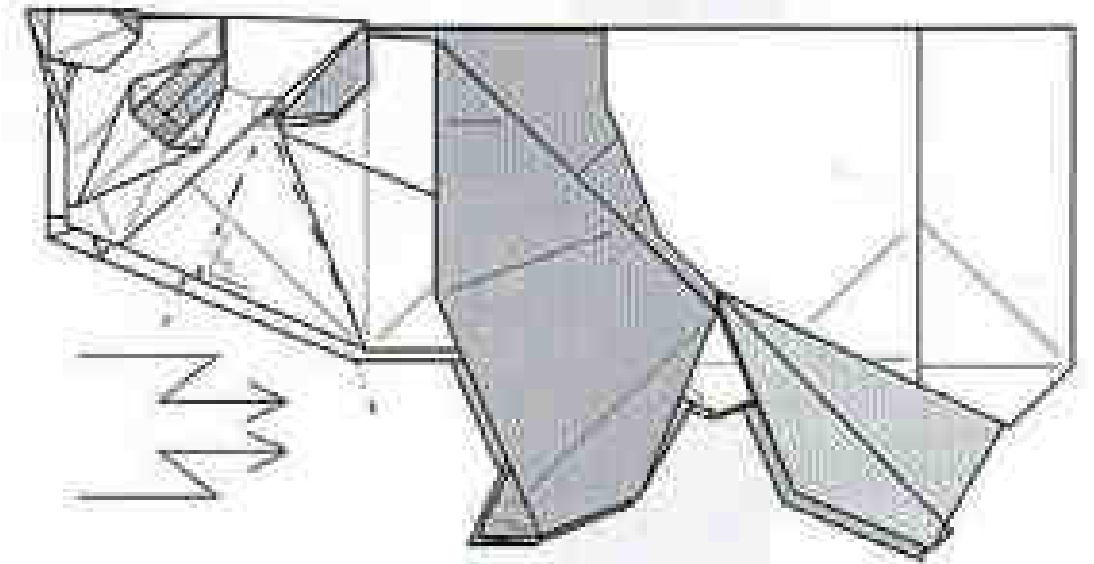

73

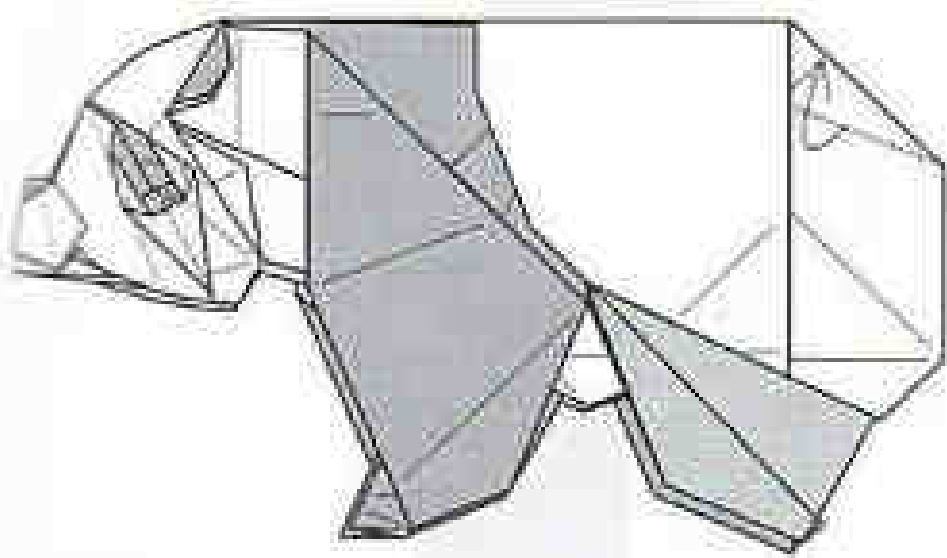

69

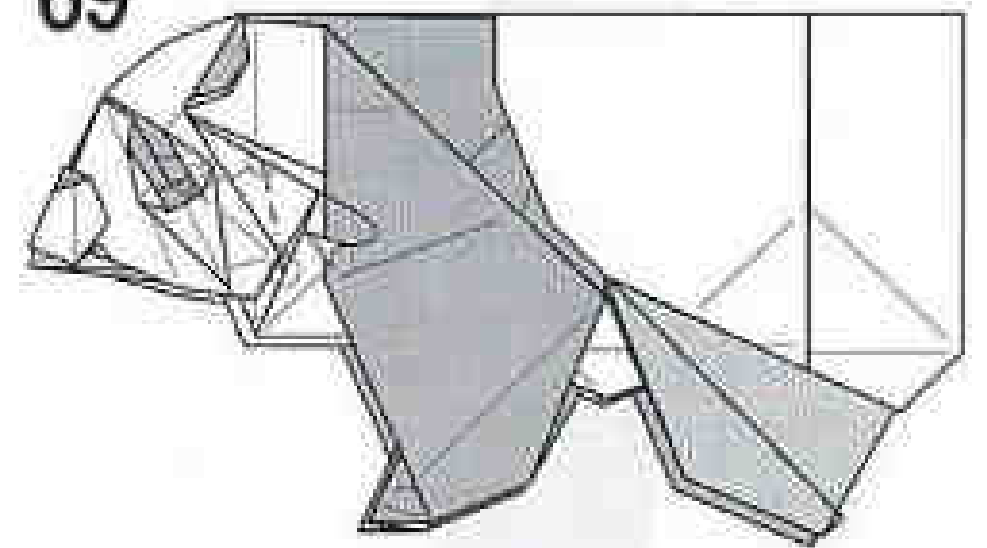

72

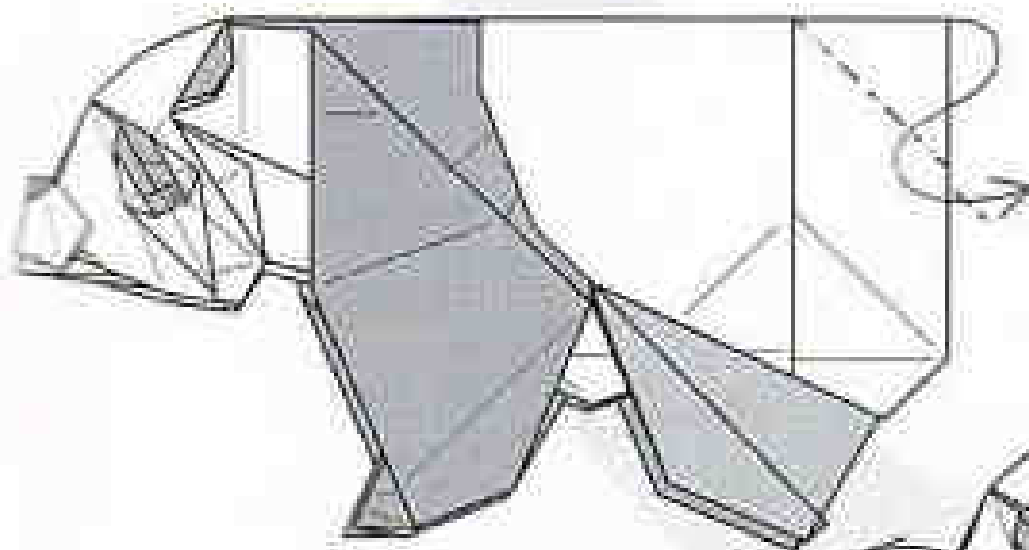

반대쪽도 반복합니다.

70

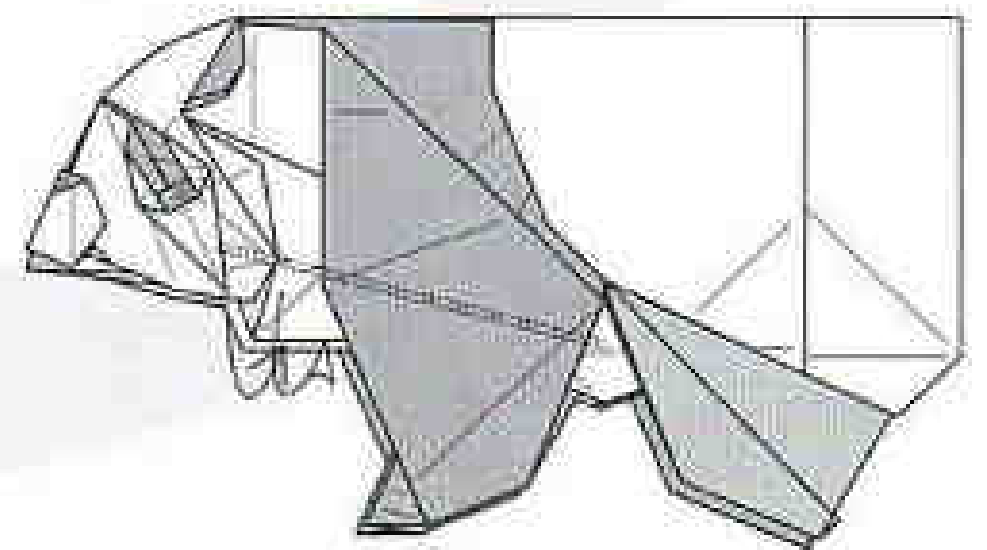

71

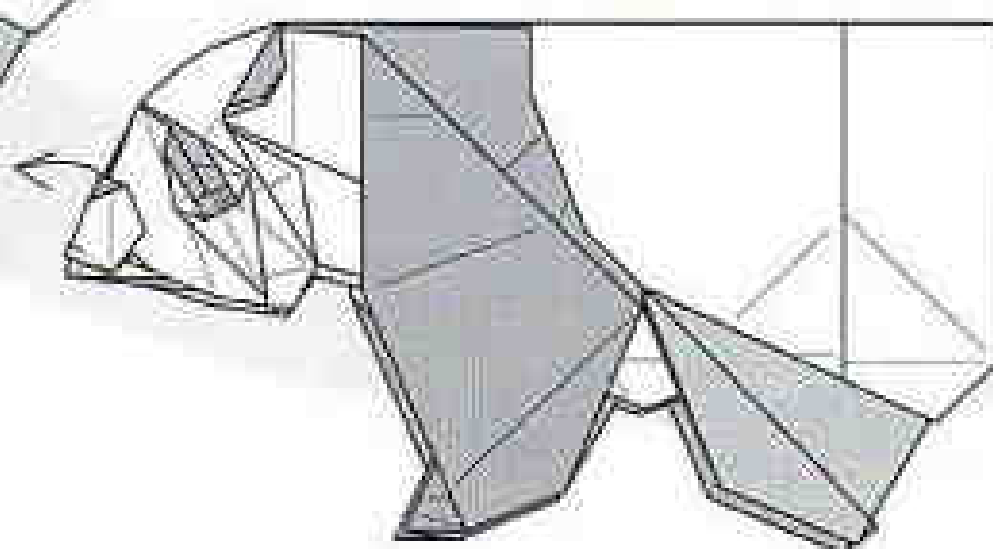

돌고래 (Dolphin)

창작가 : 유태용 (Yoo Tae Yong)

다이어그램 : 유태용 (Yoo Tae Yong)

창작일 : 2015.06.30

종이크기 : 40cm x 40cm

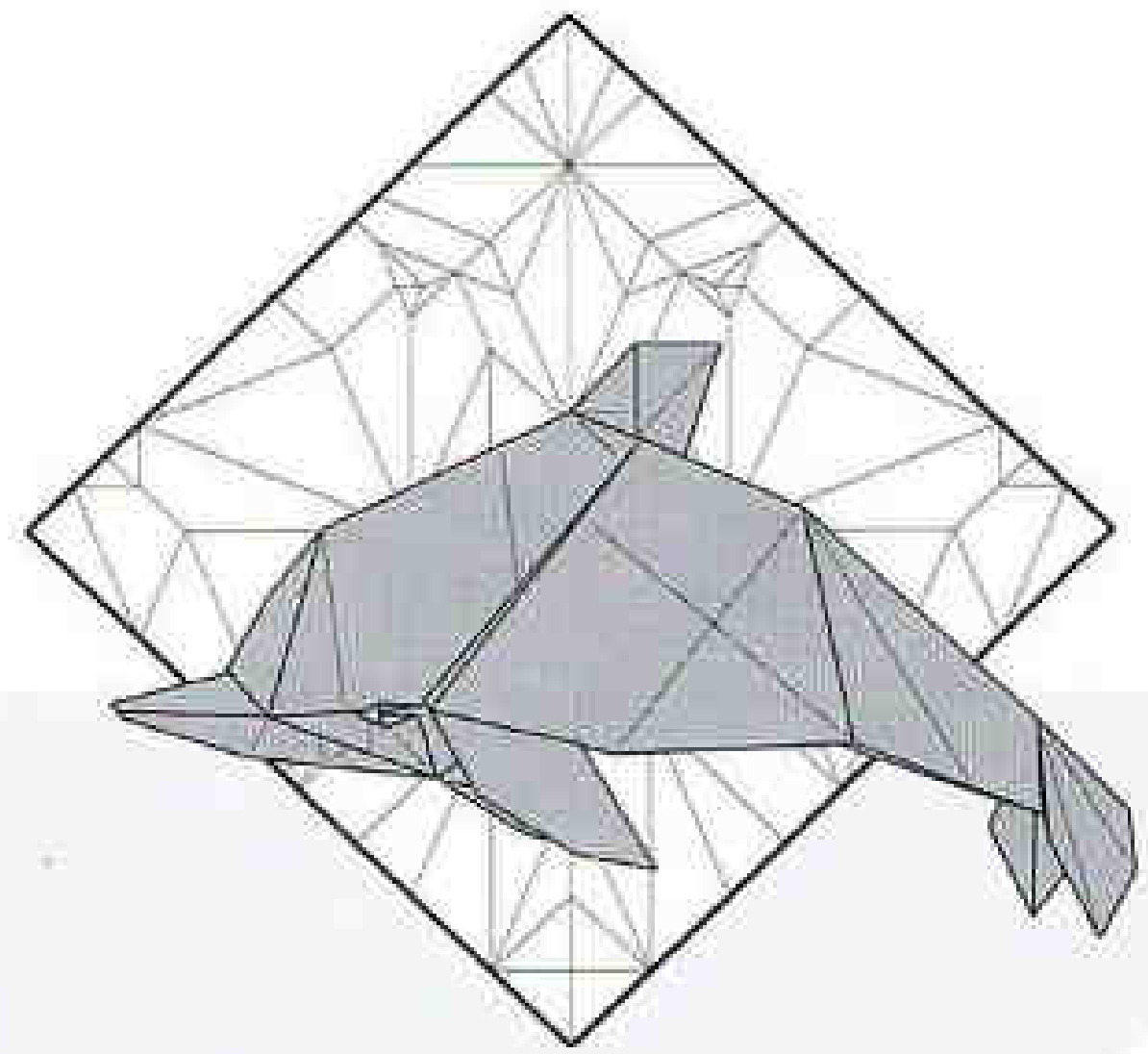

디자인이 가장 어려웠던 작품입니다. 얼굴 부분이 많은 시간을 필요 했고 등지느러미 부분에서도 문제가 있었지만 구조의 특이함 덕분이었는지 생각보다 간단하게 마무리할 수 있었습니다. 하지만 여분이 많이 남은 부분이 있어 해결을 해야 했지만 벌어지는 부분을 고정하는 방법으로 마무리하니 여분이 남아서 오히려 다행이라고 생각합니다.

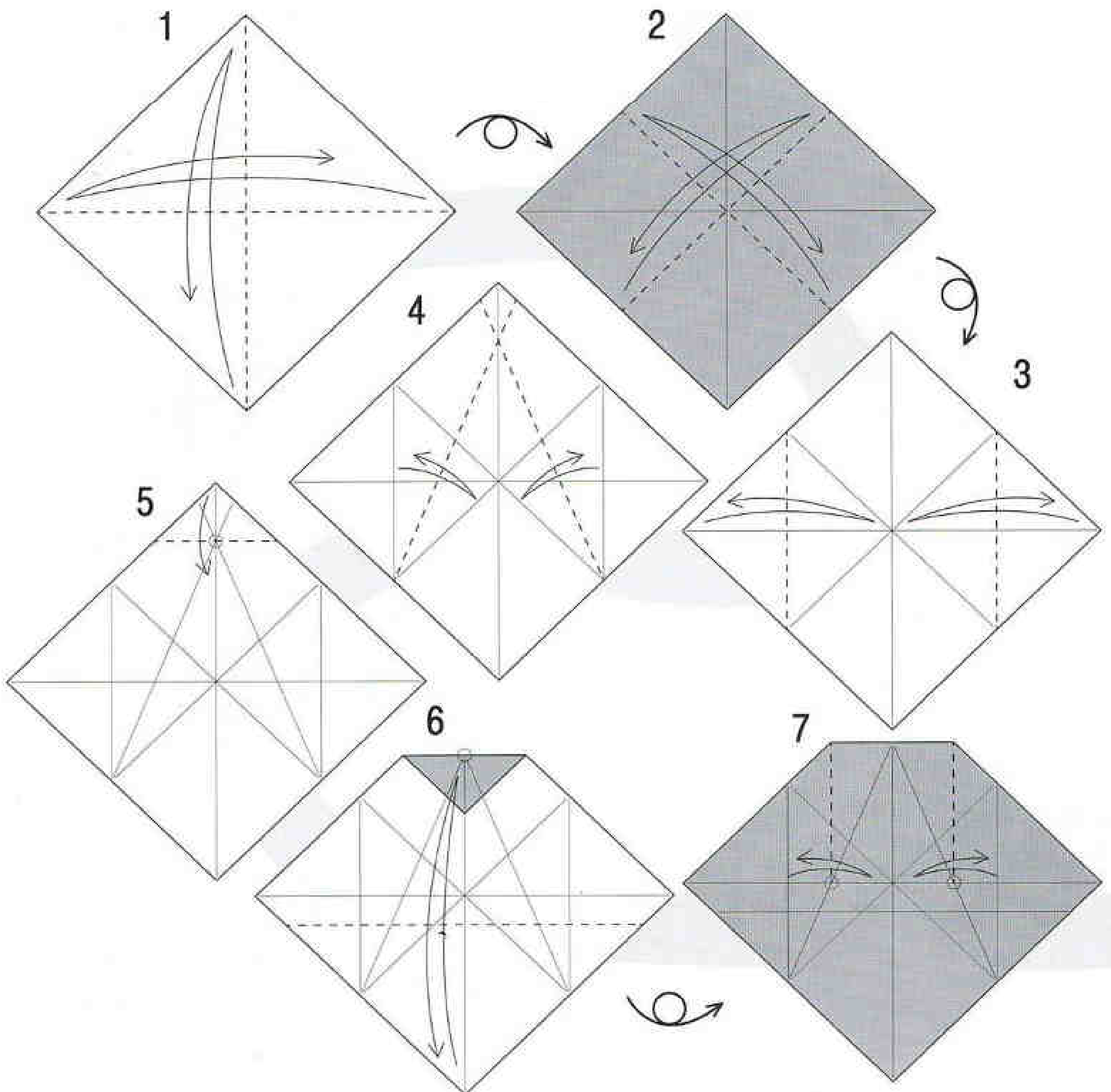

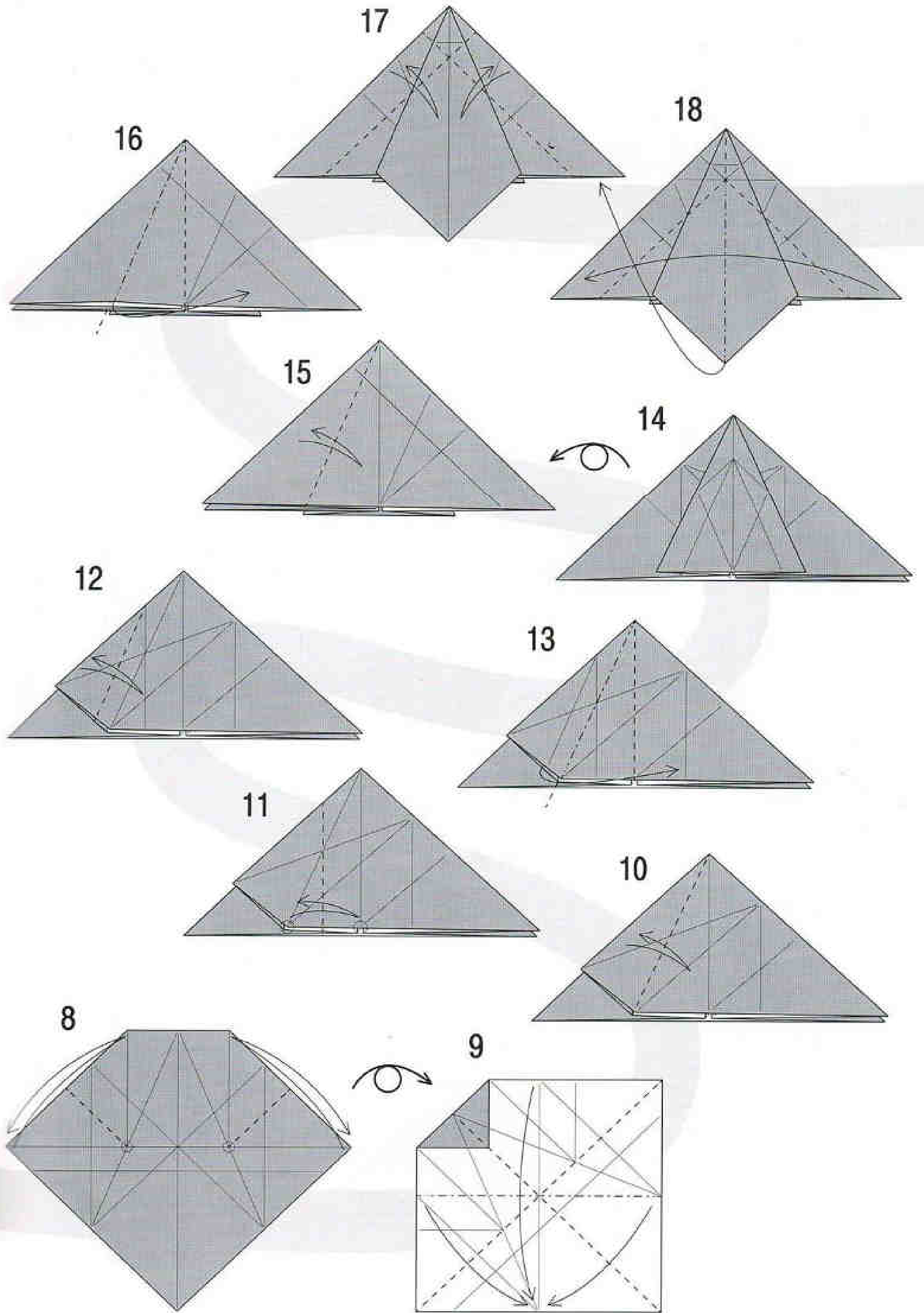

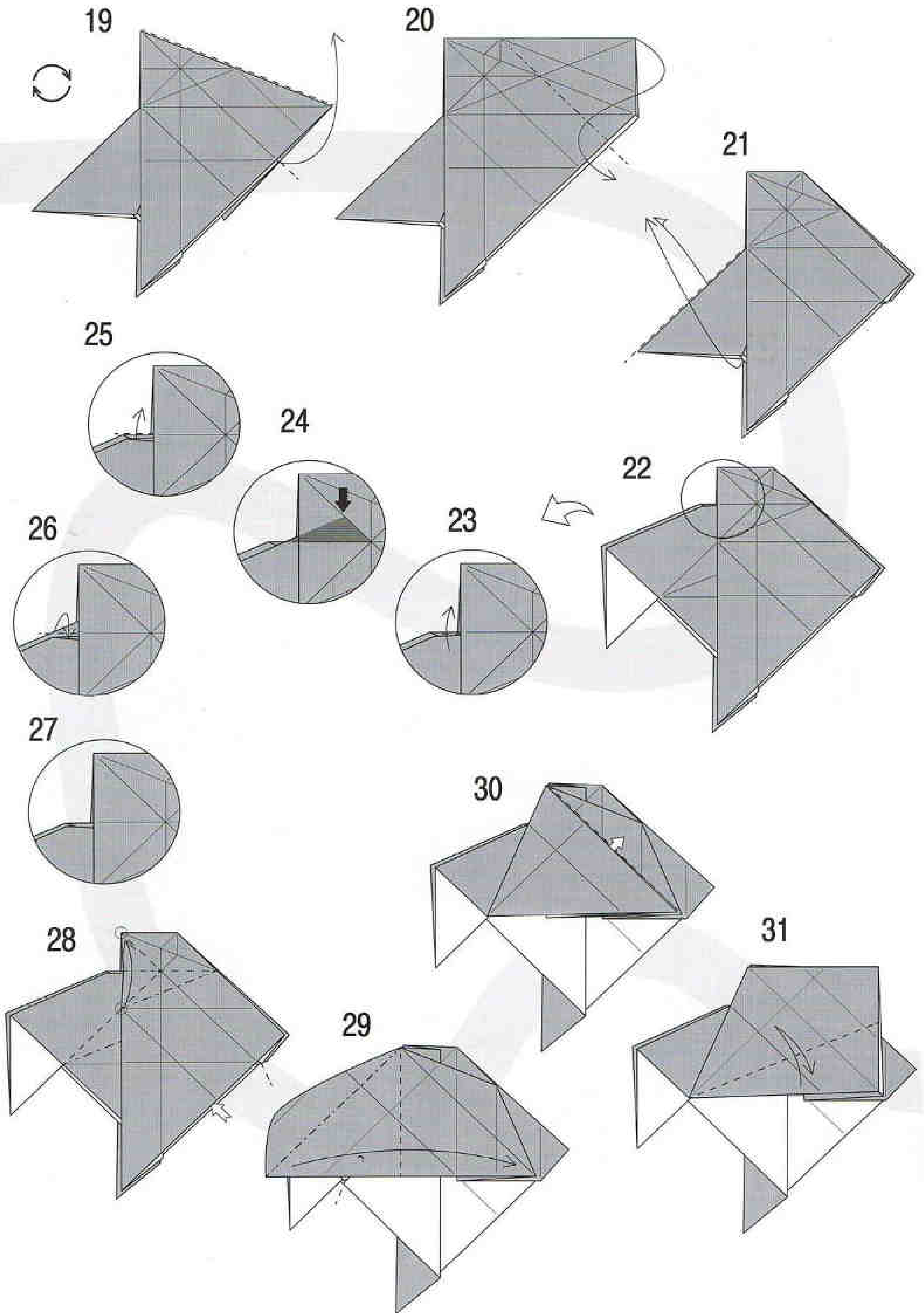

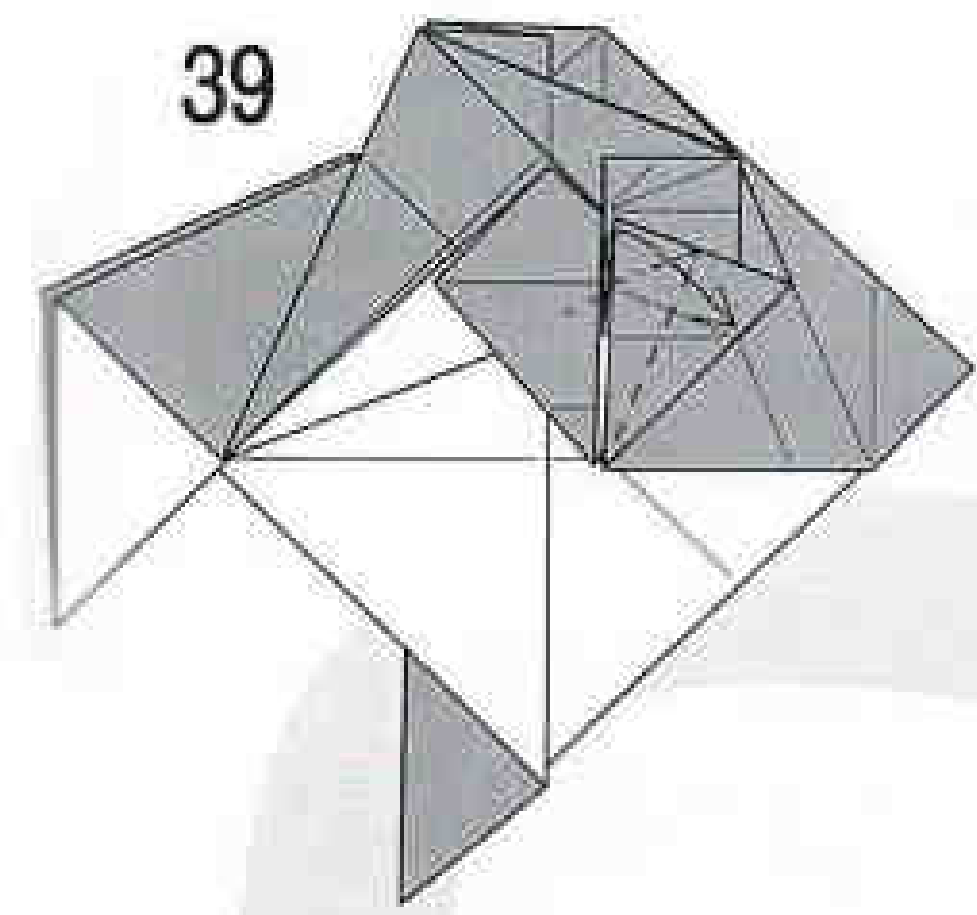

39

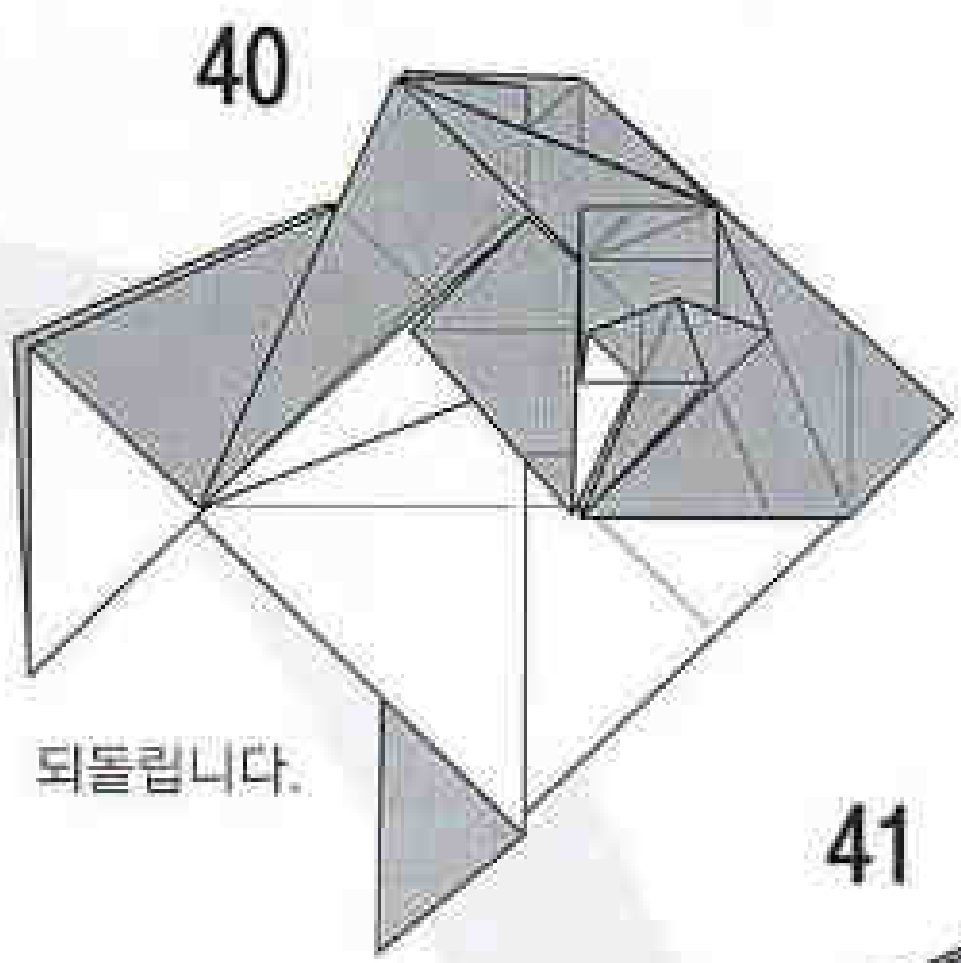

40

뒤돌립니다.

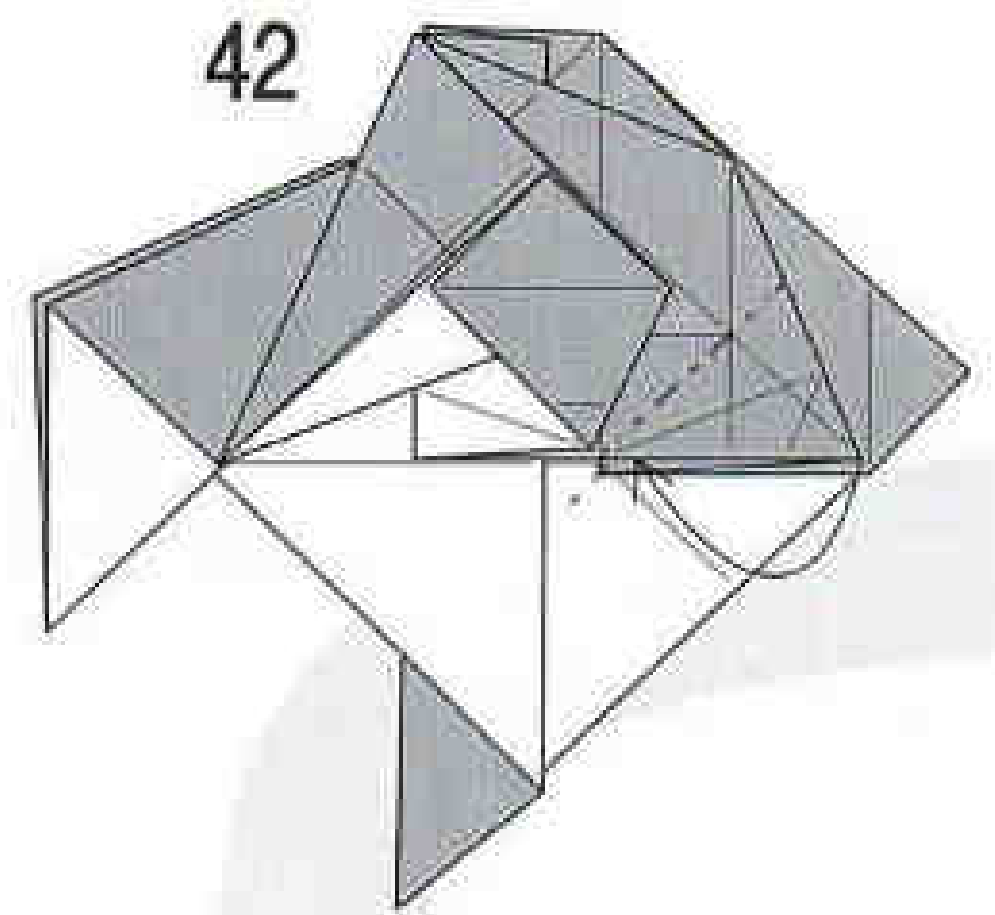

42

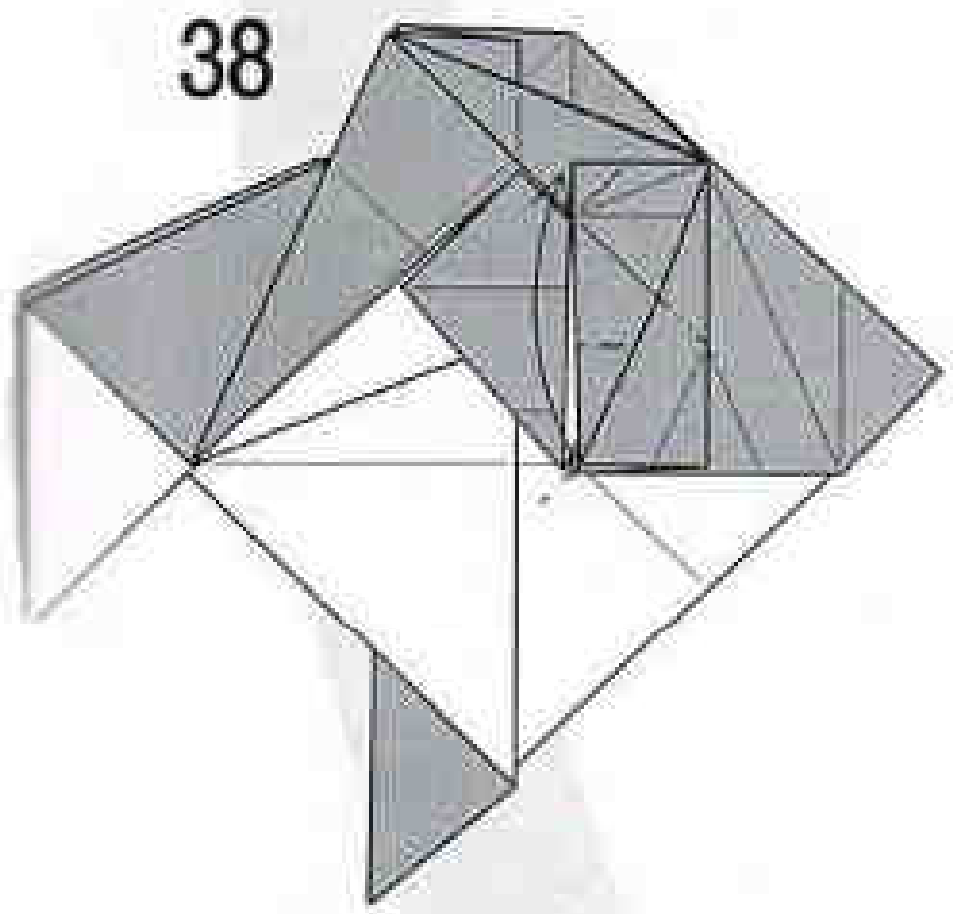

38

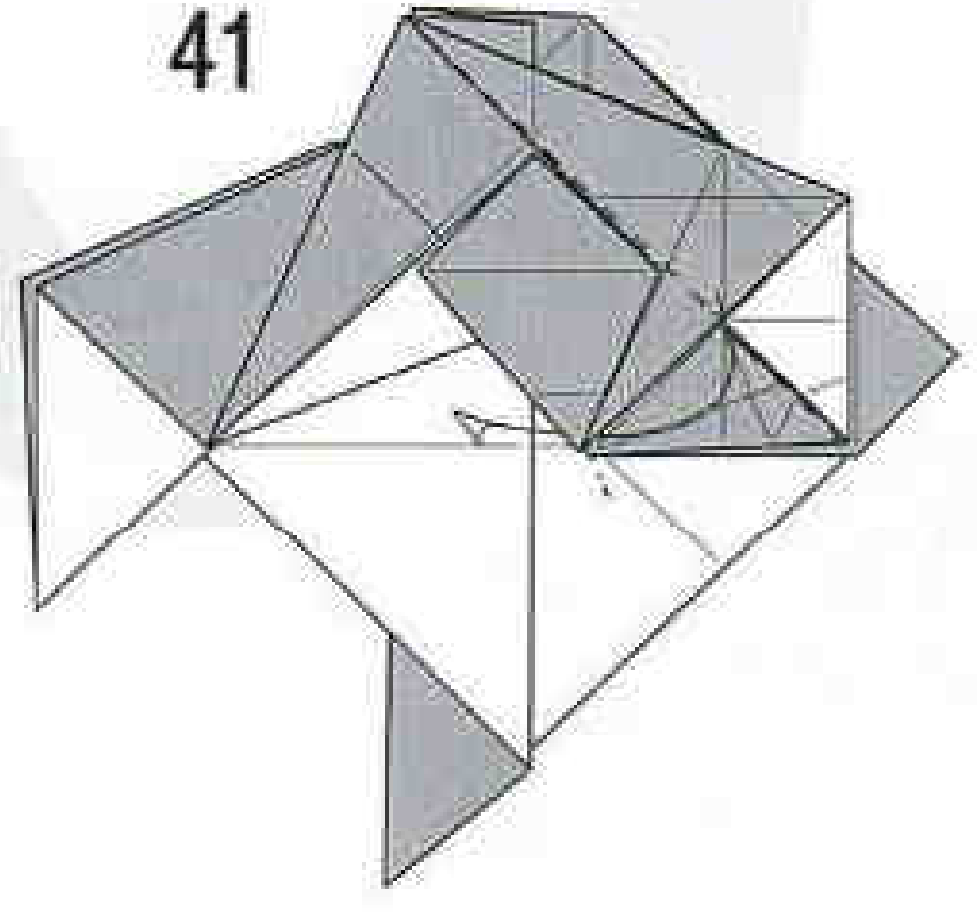

41

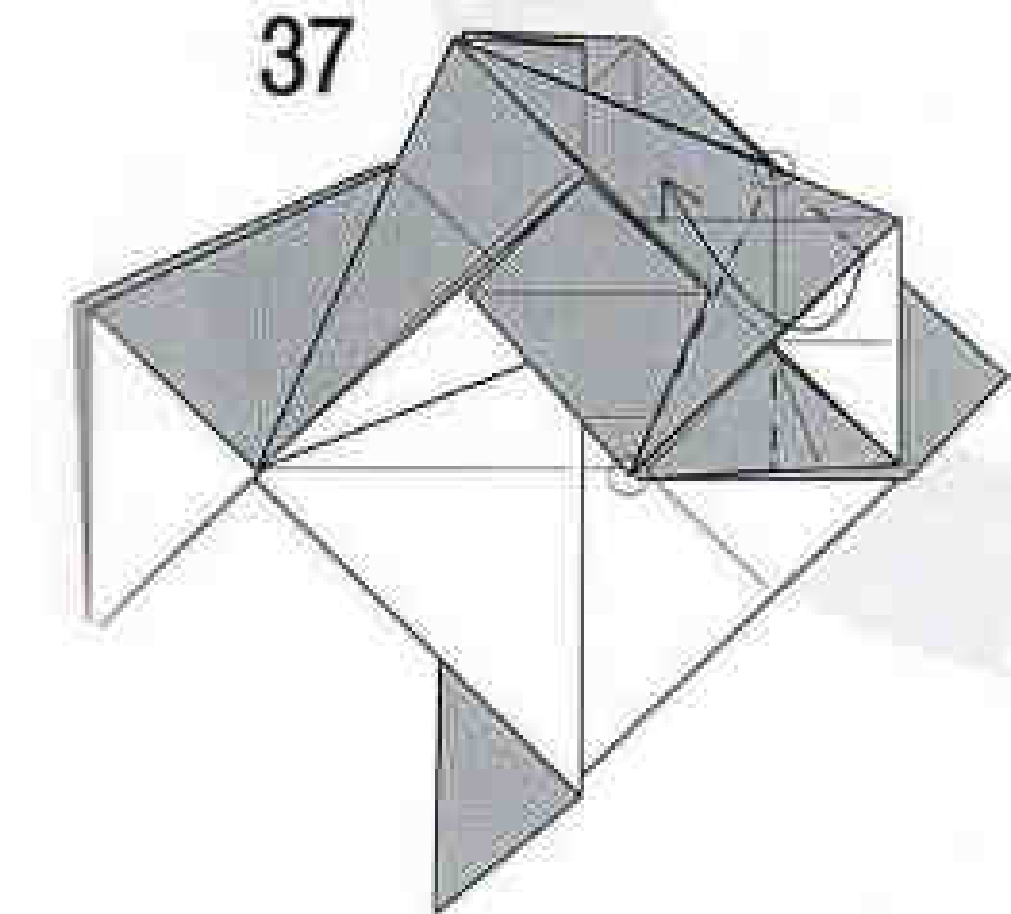

37

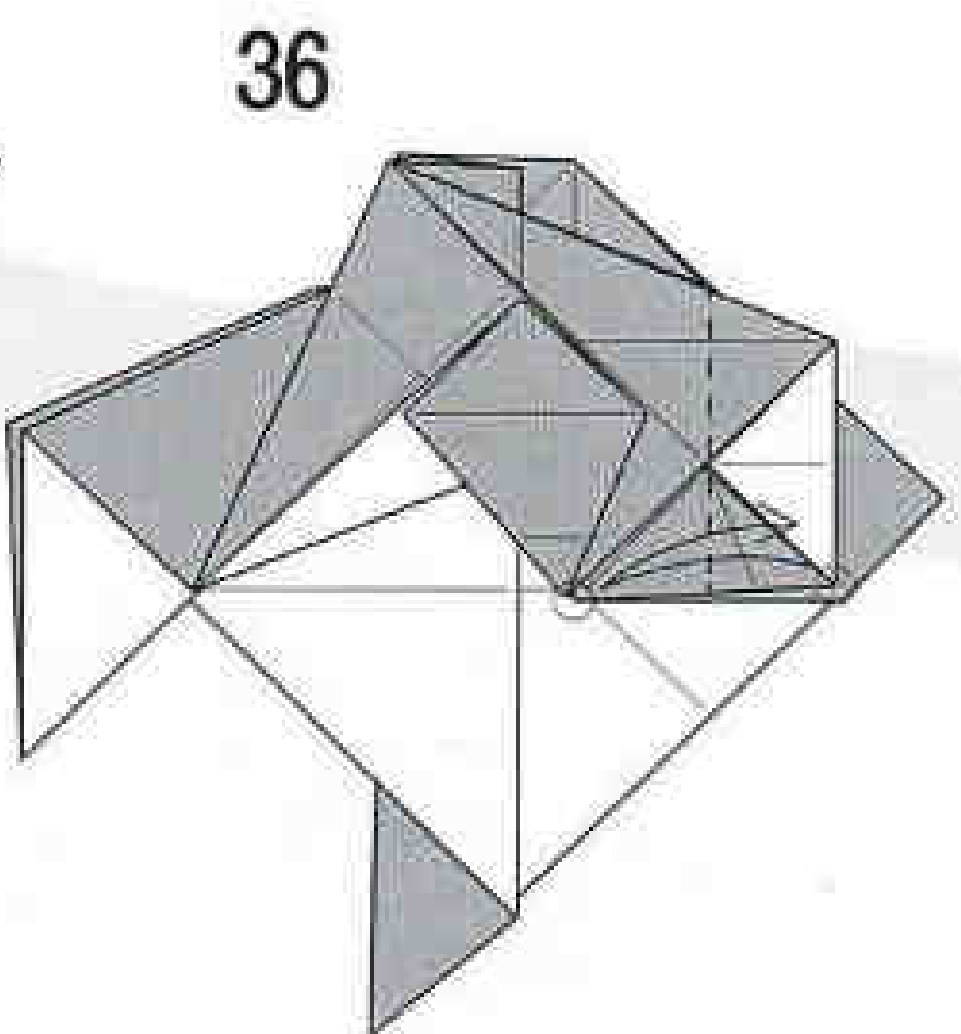

36

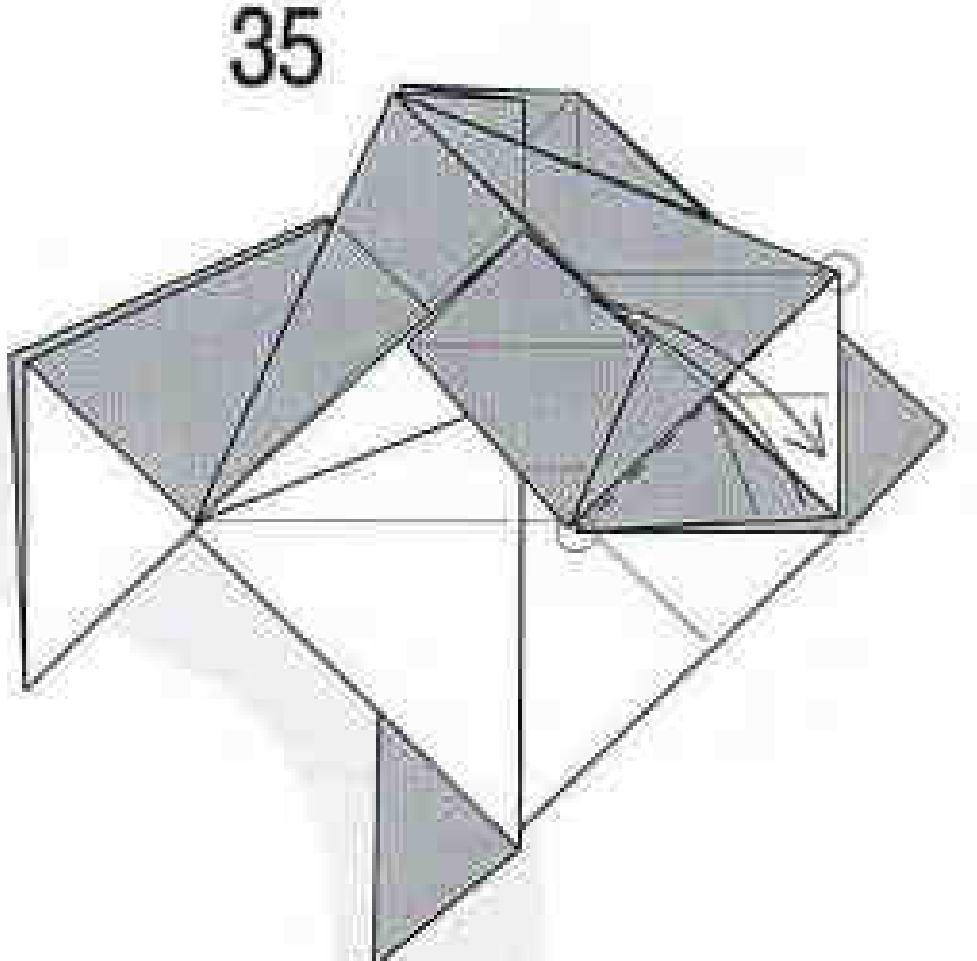

35

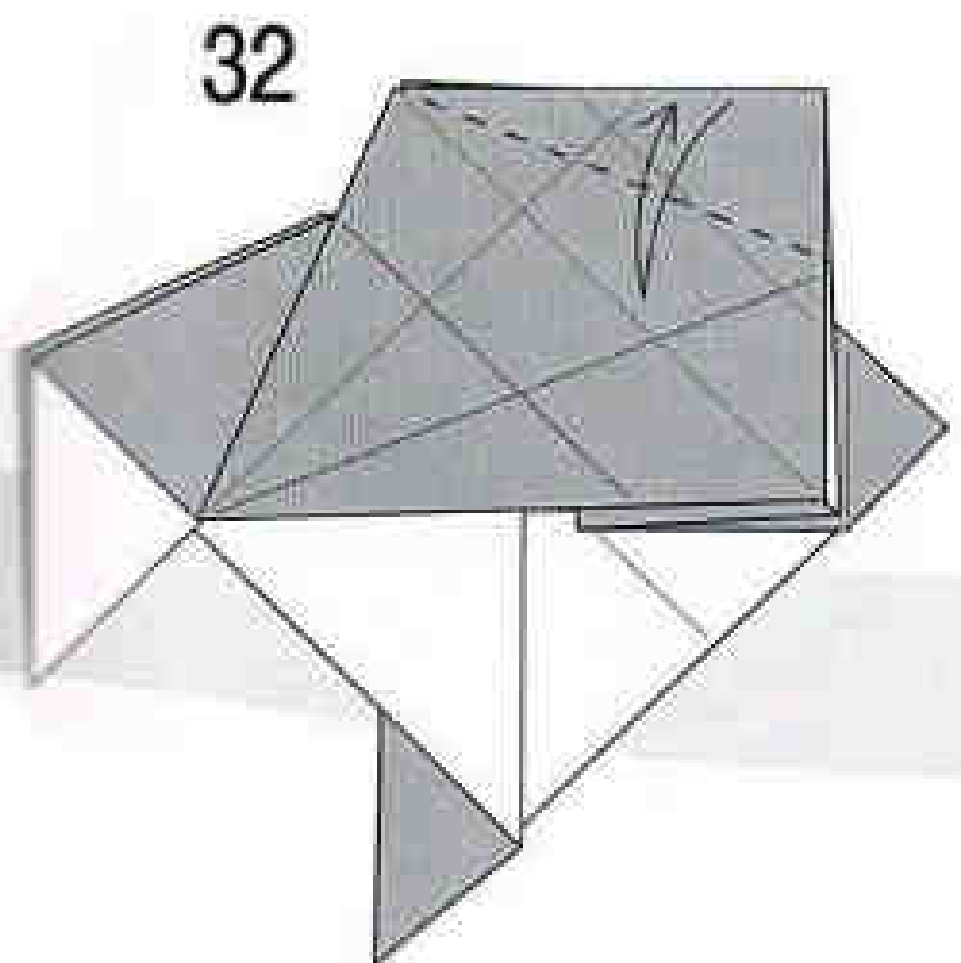

32

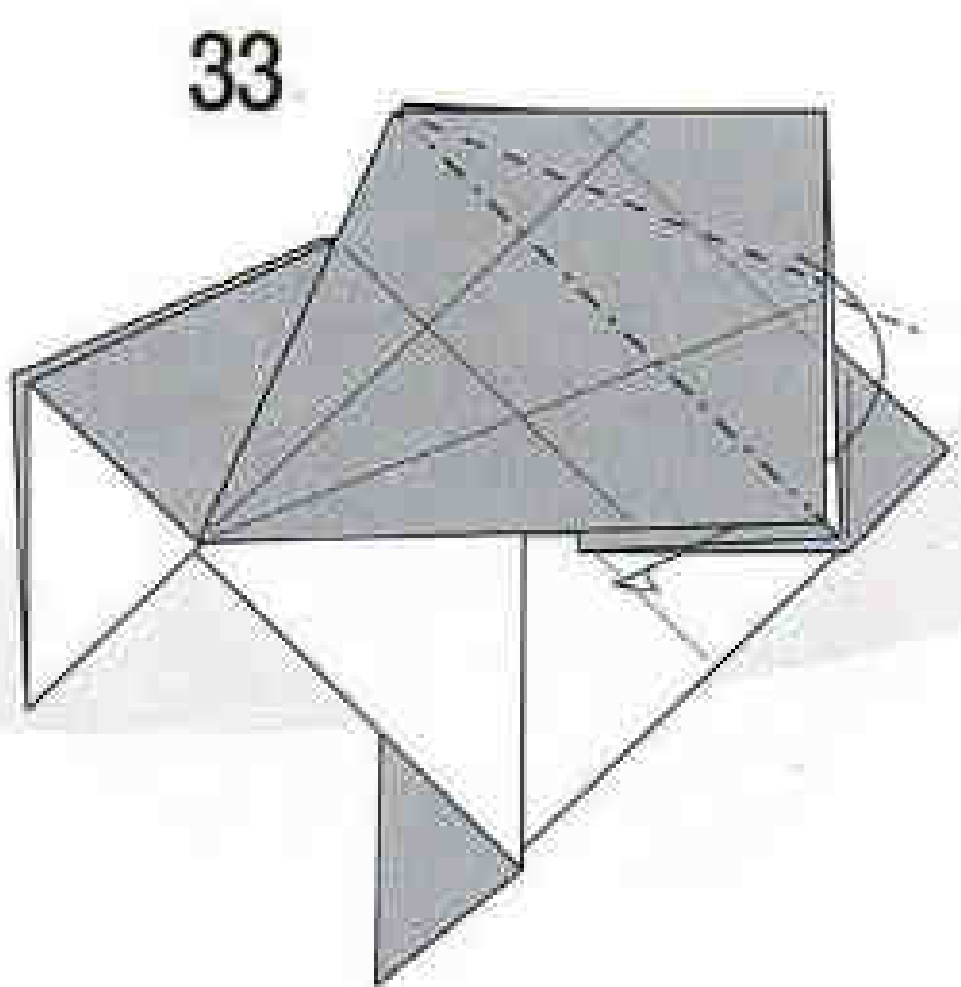

33

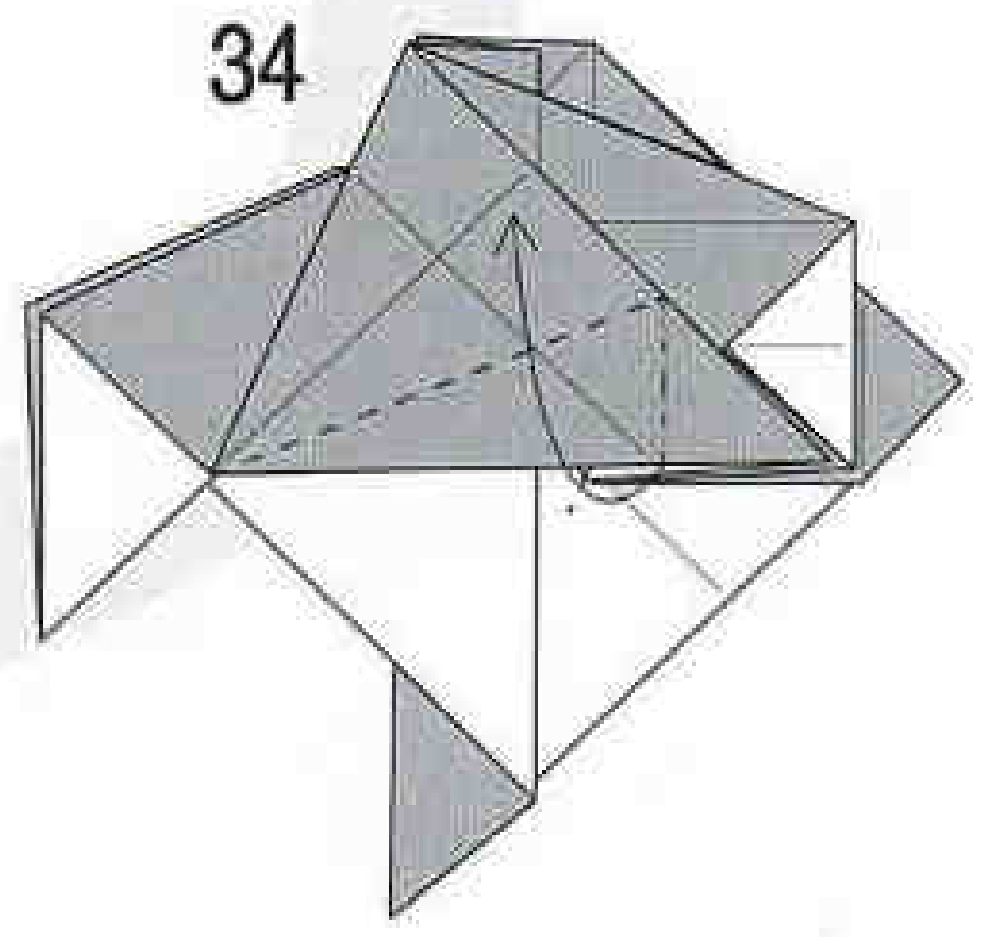

34

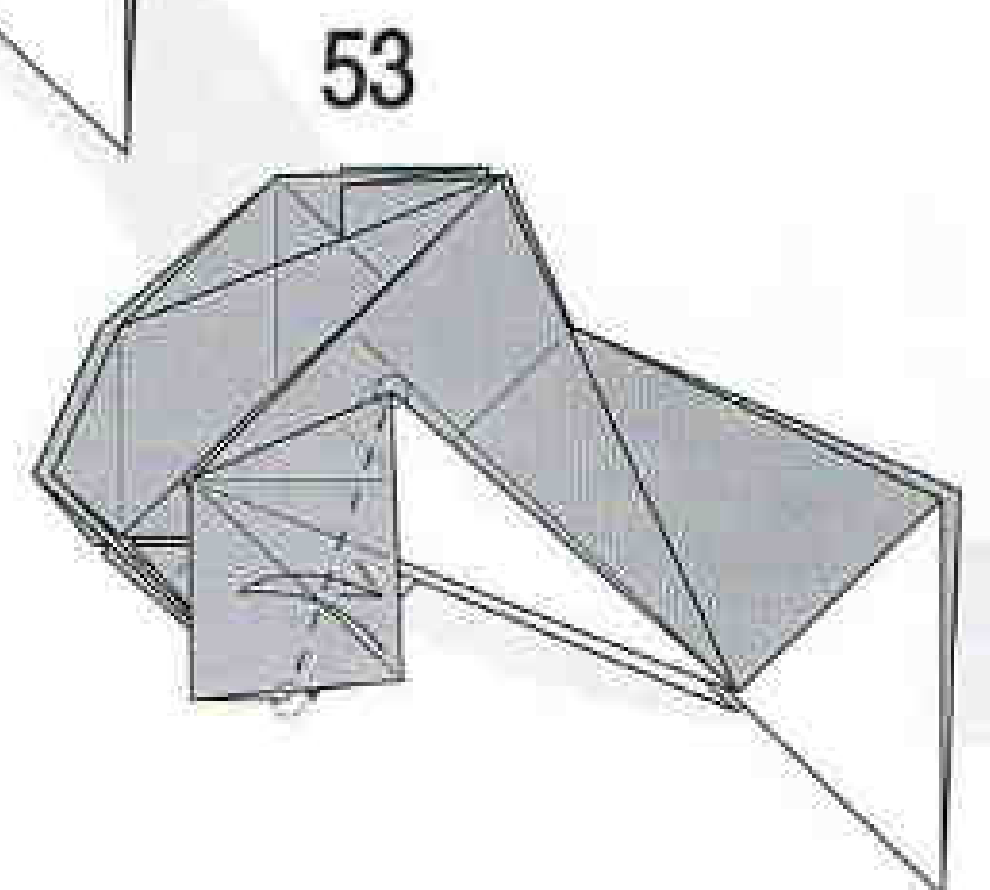
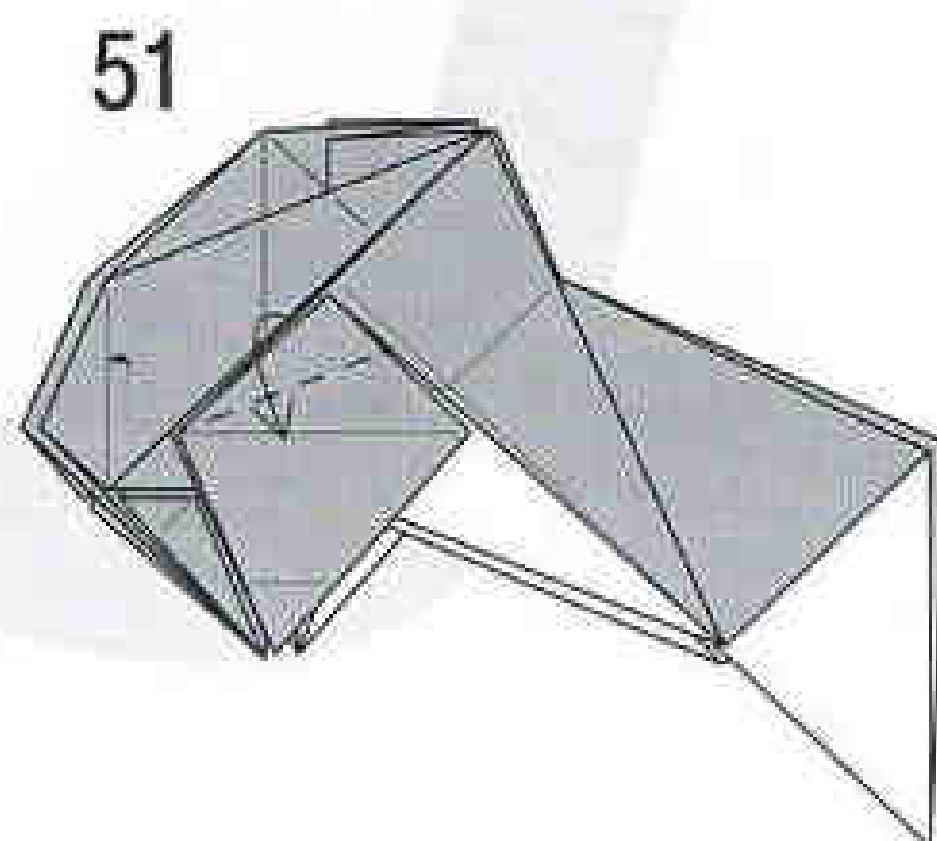
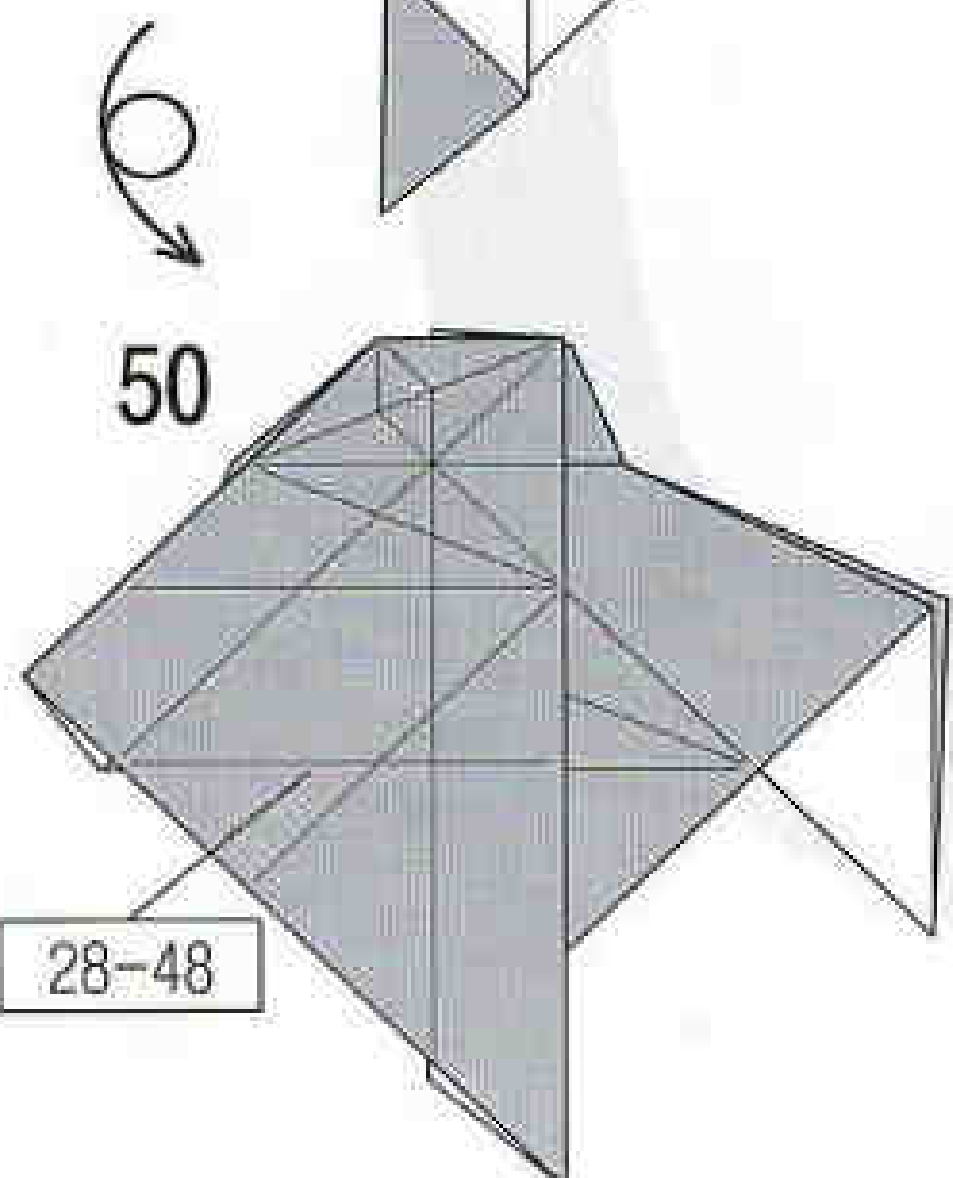
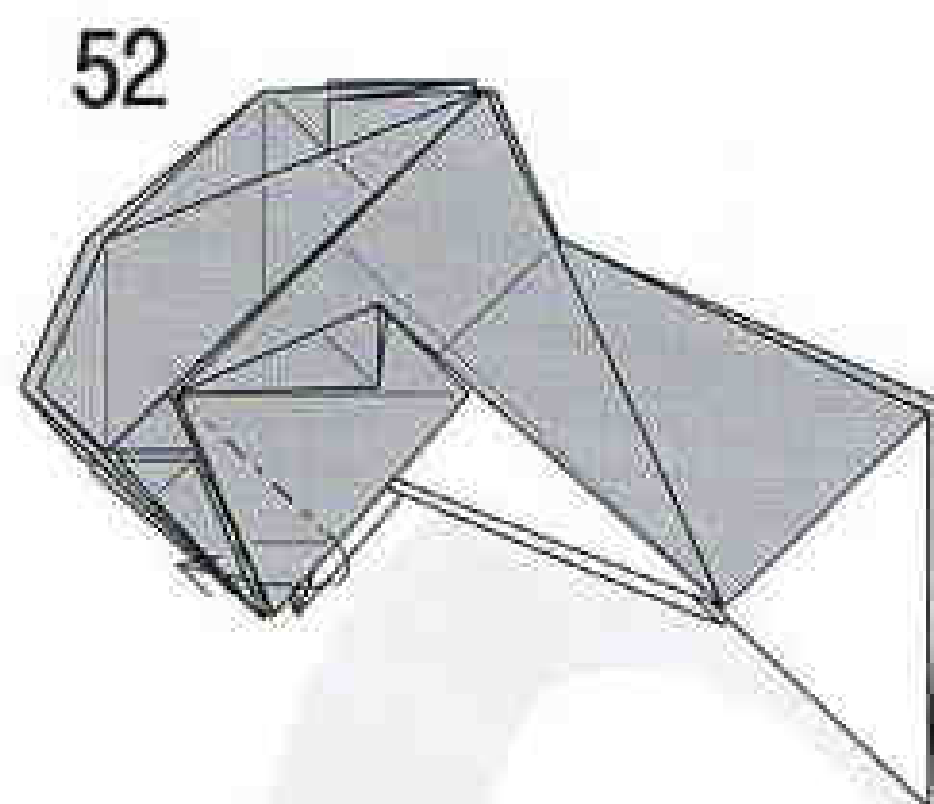
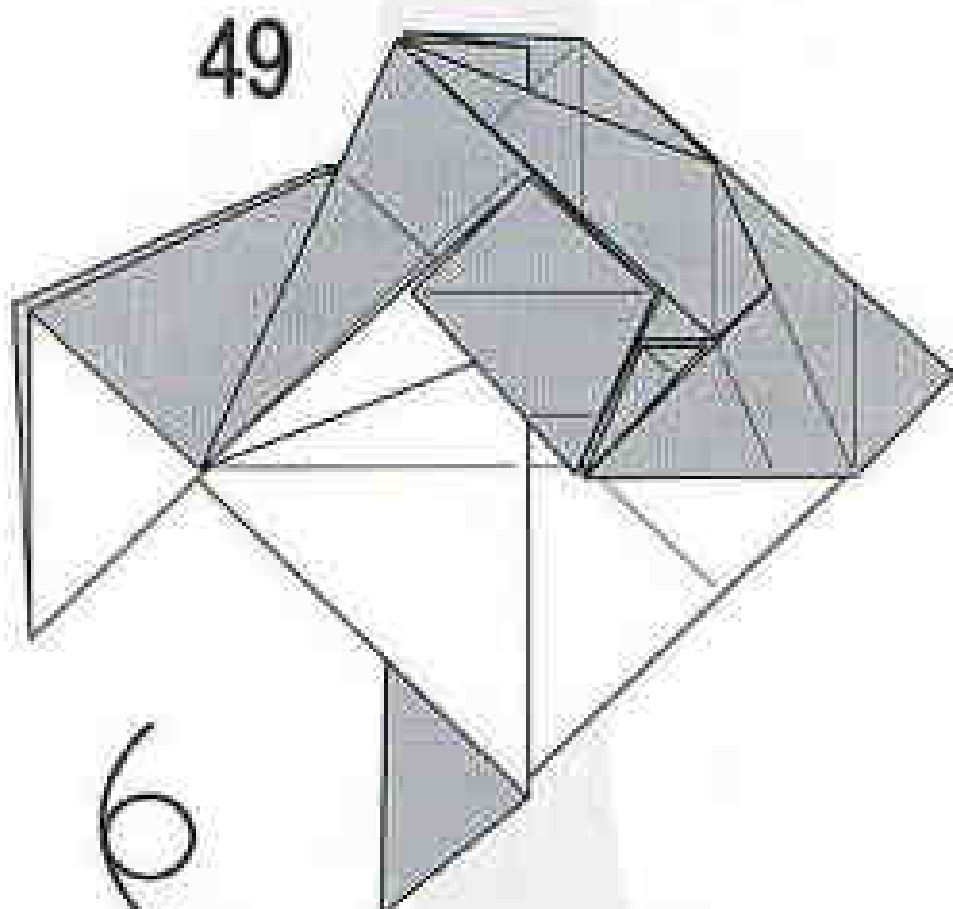
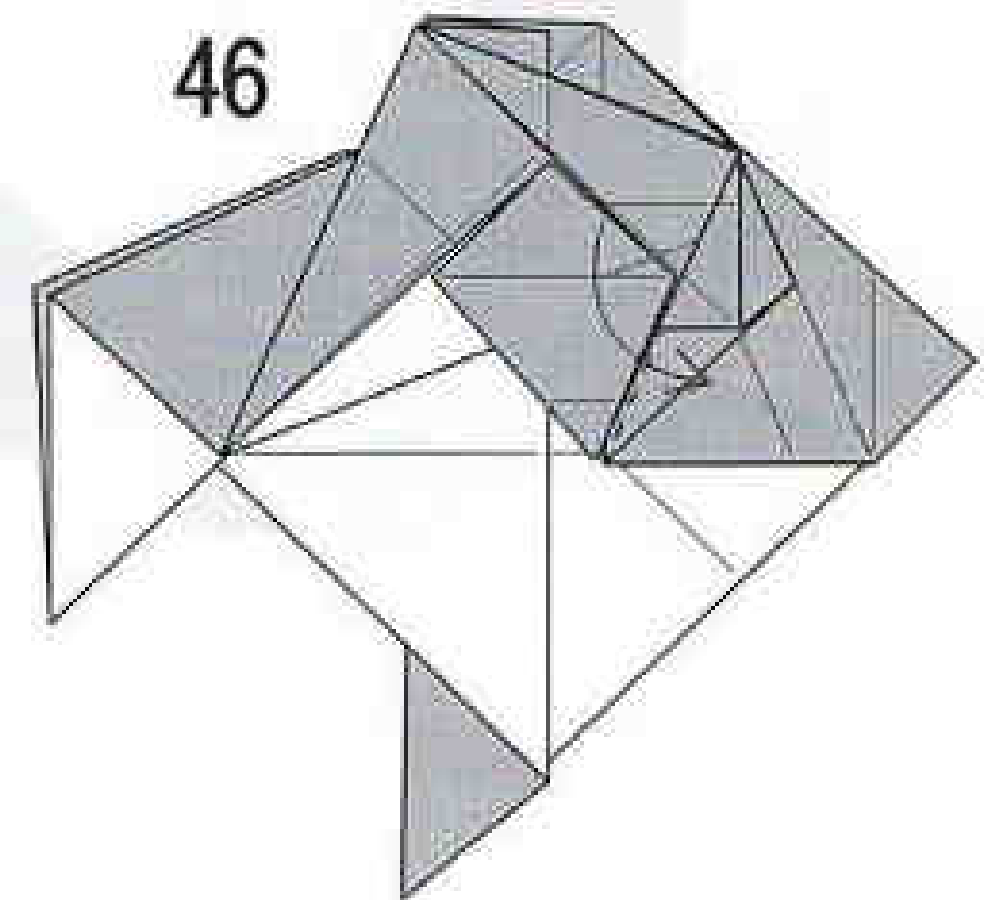
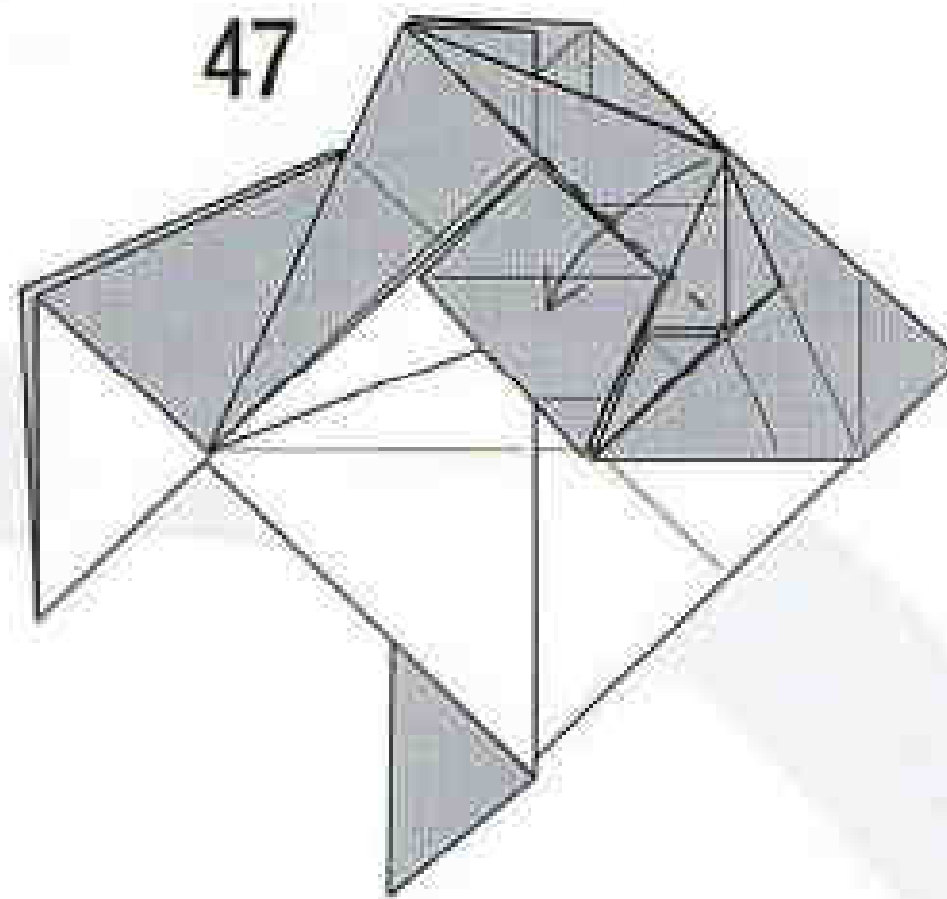
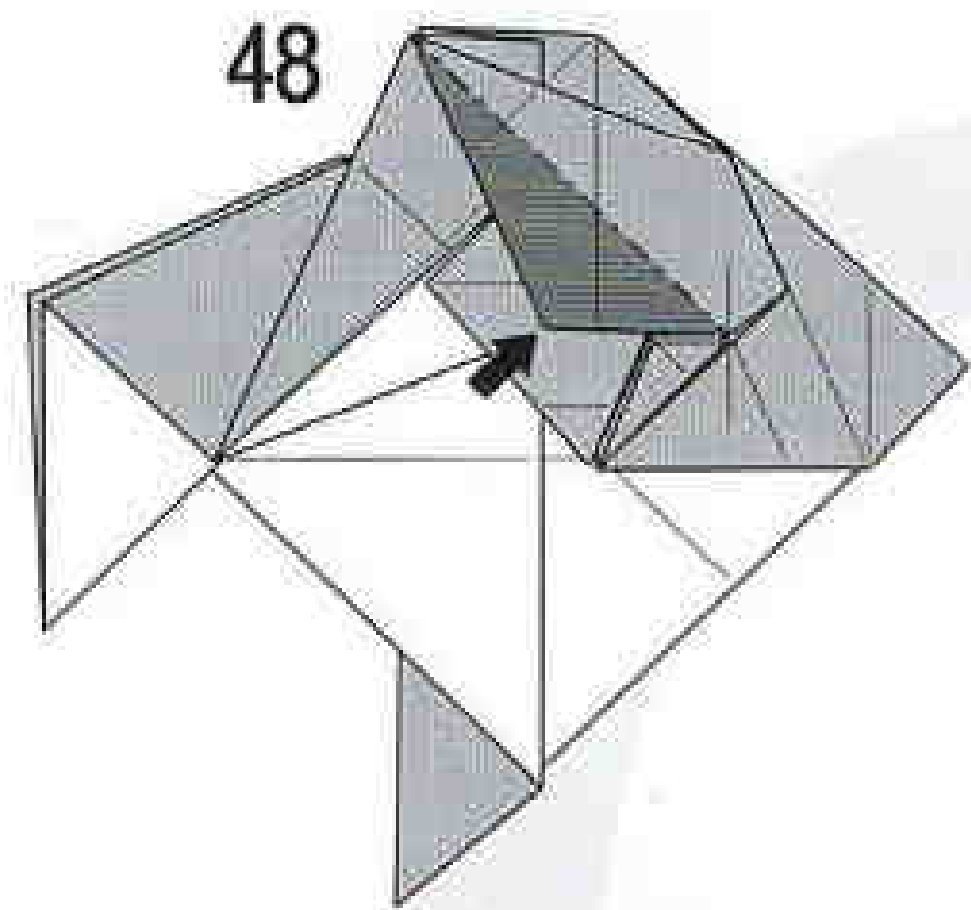
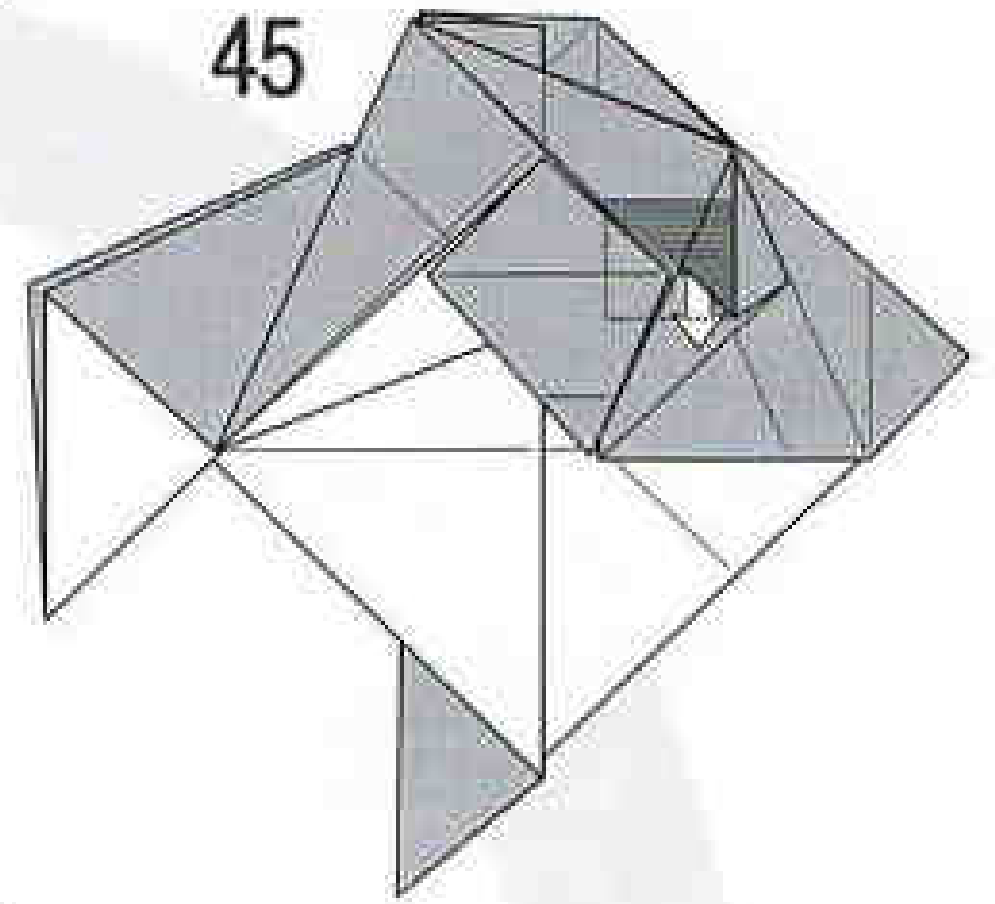
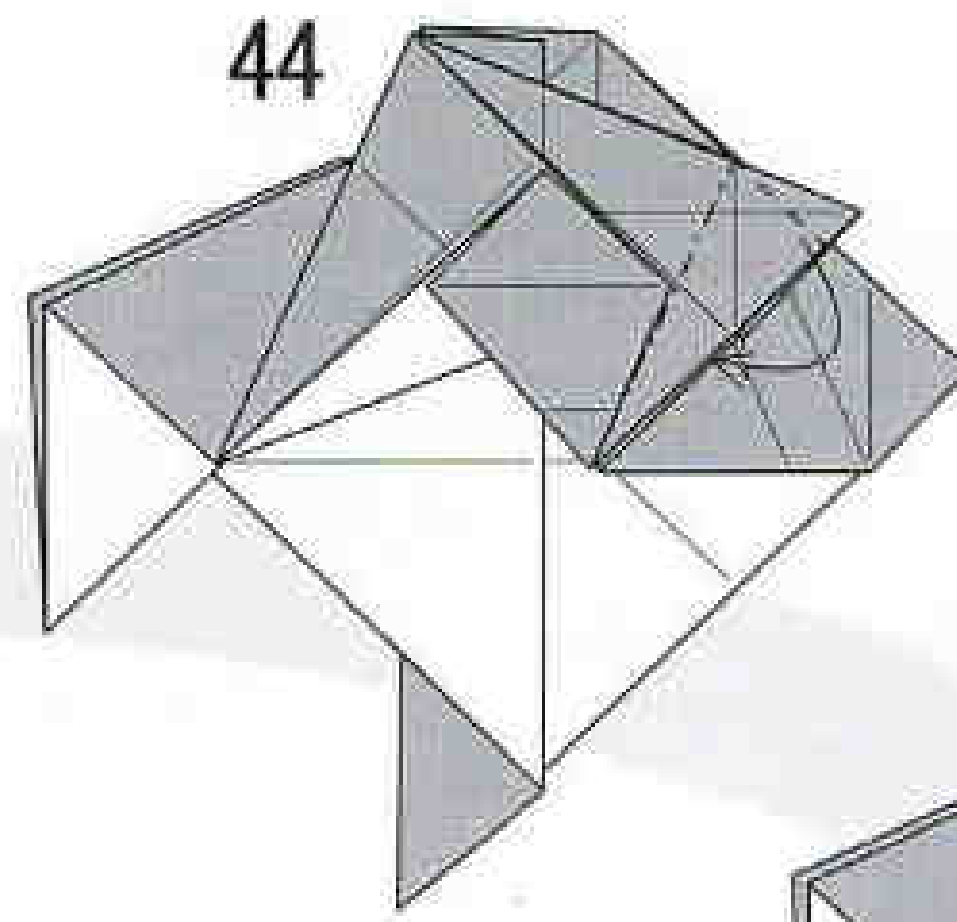
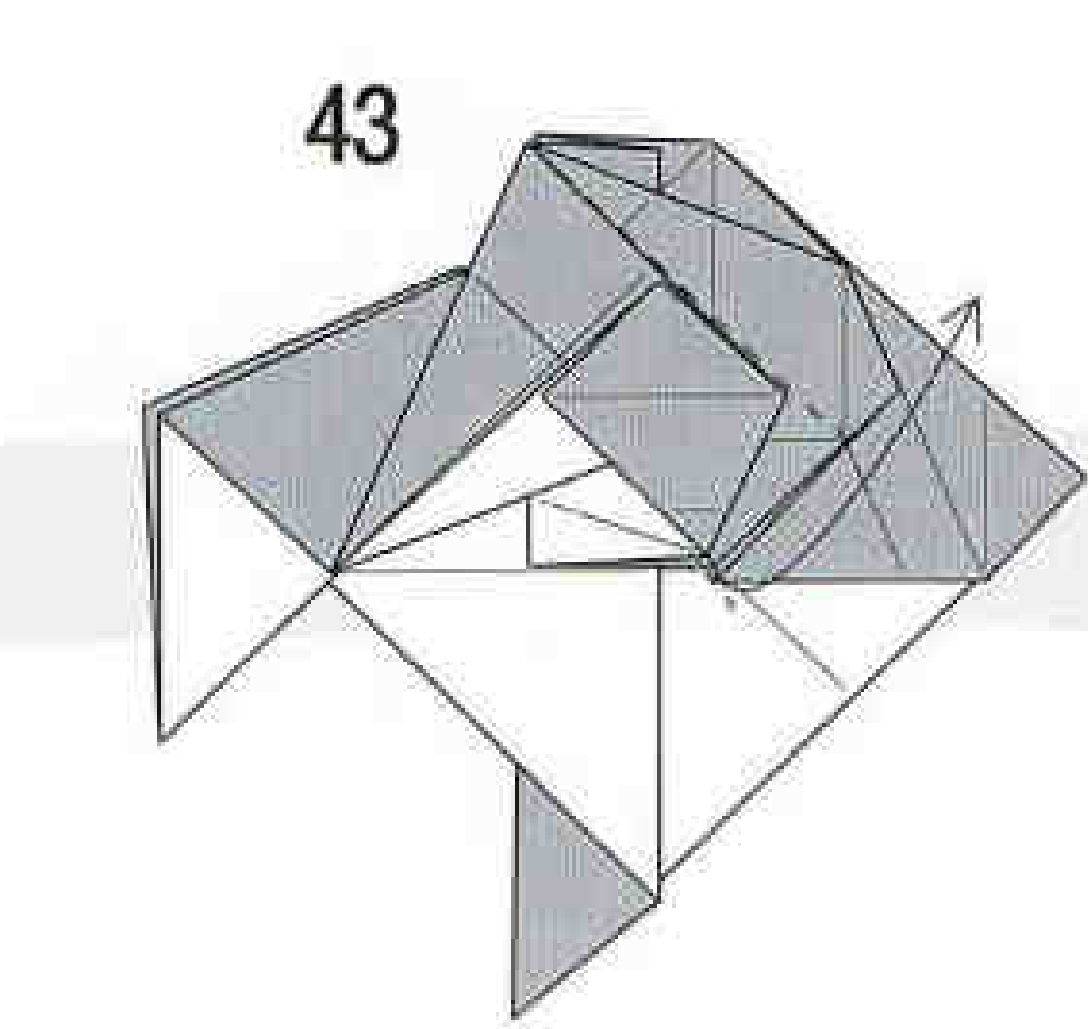

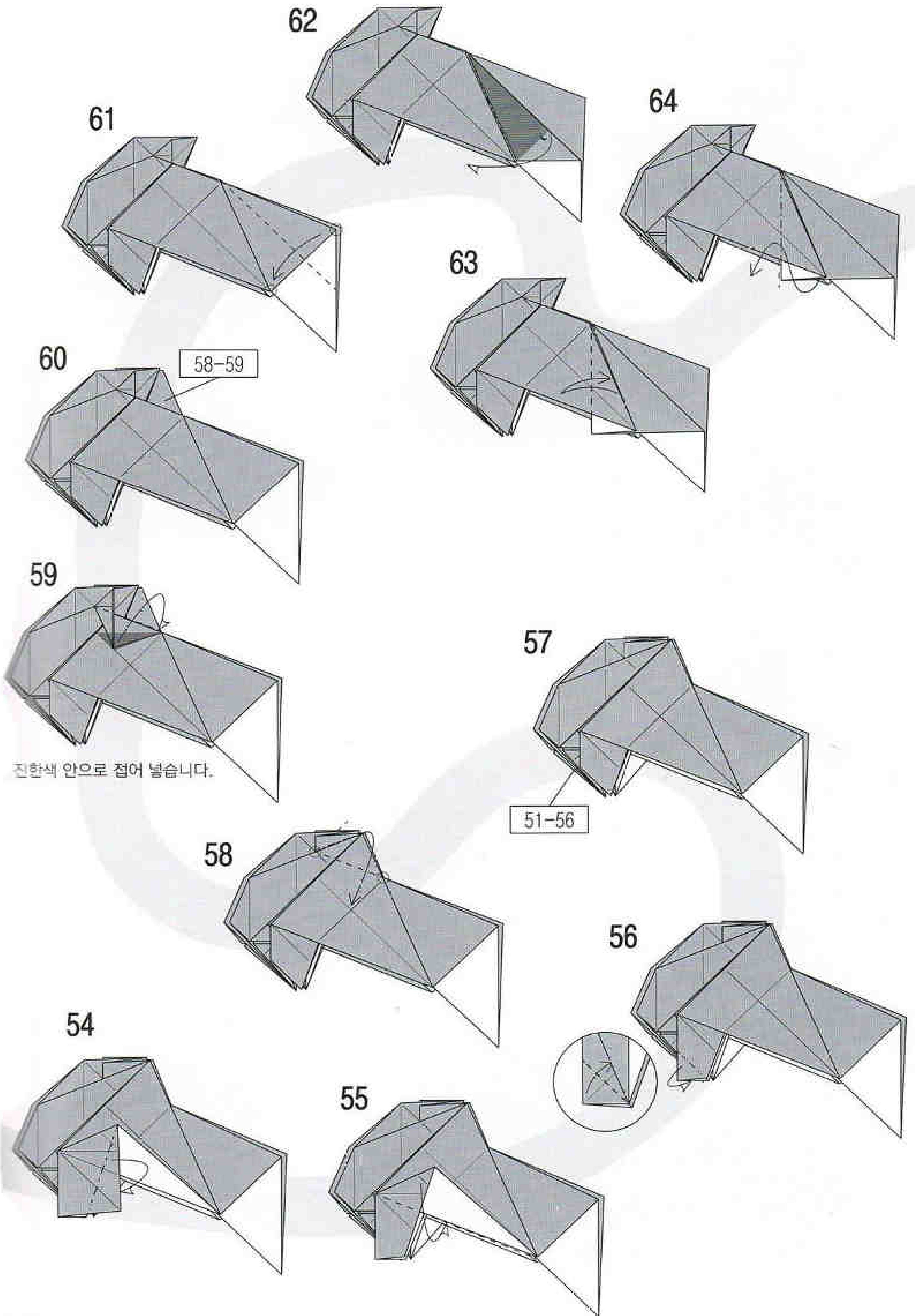

58-59

51-56

진한색 안으로 접어 넣습니다.

65

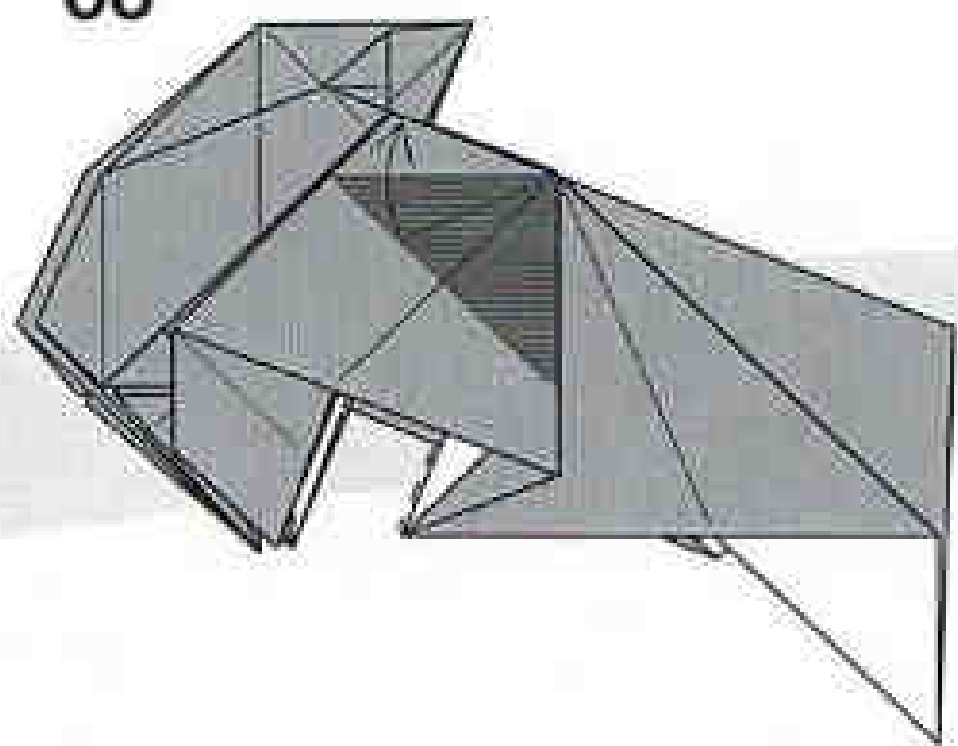

66

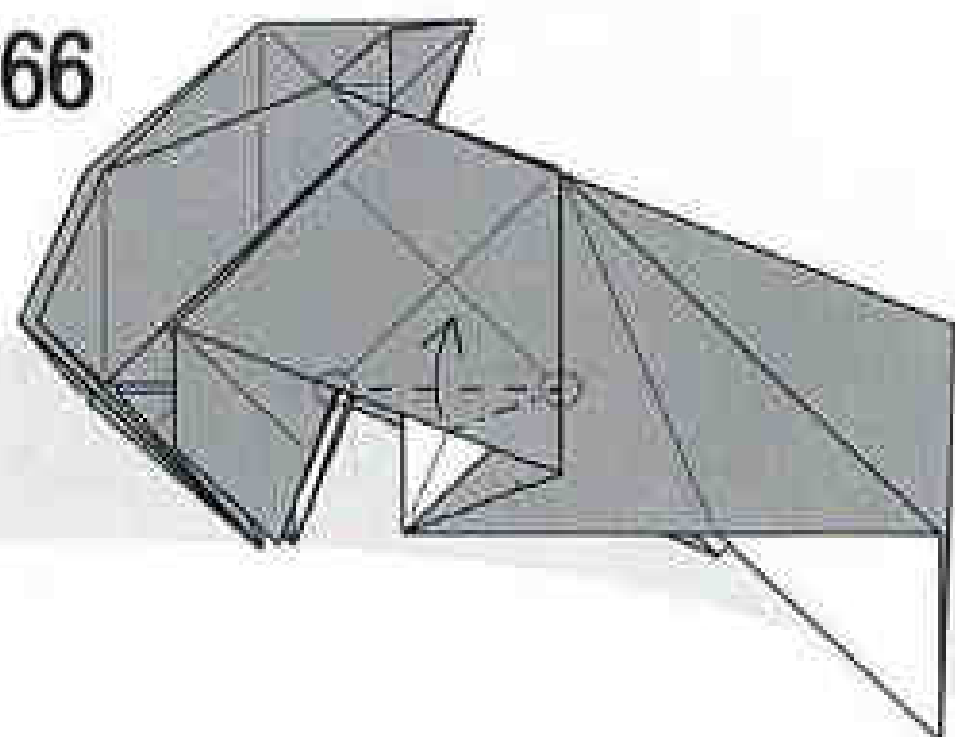

67

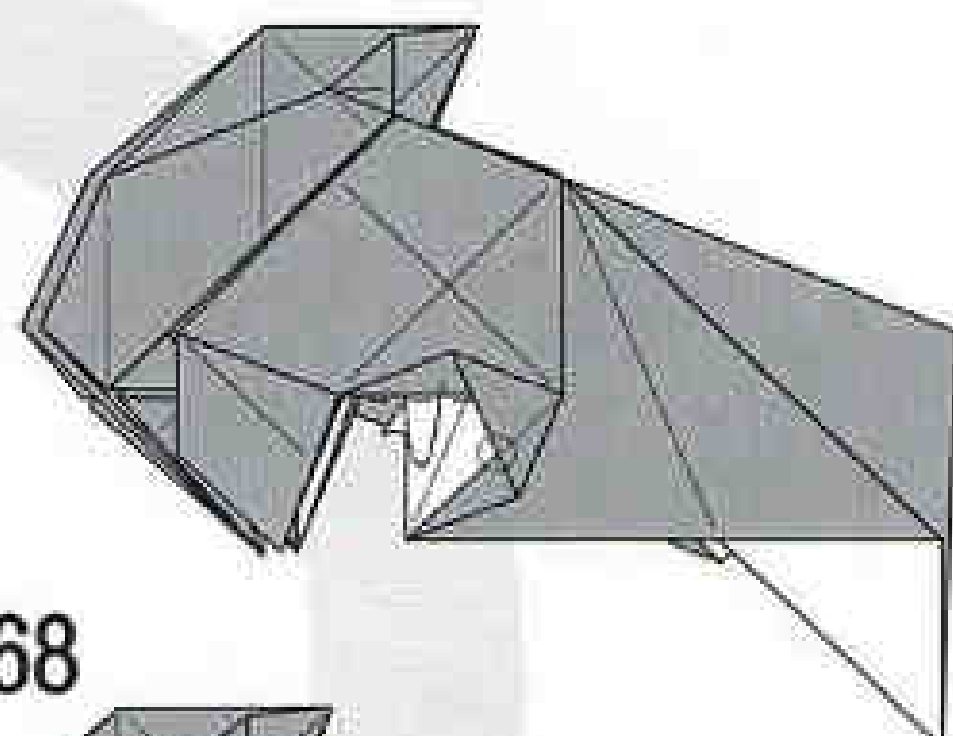

69

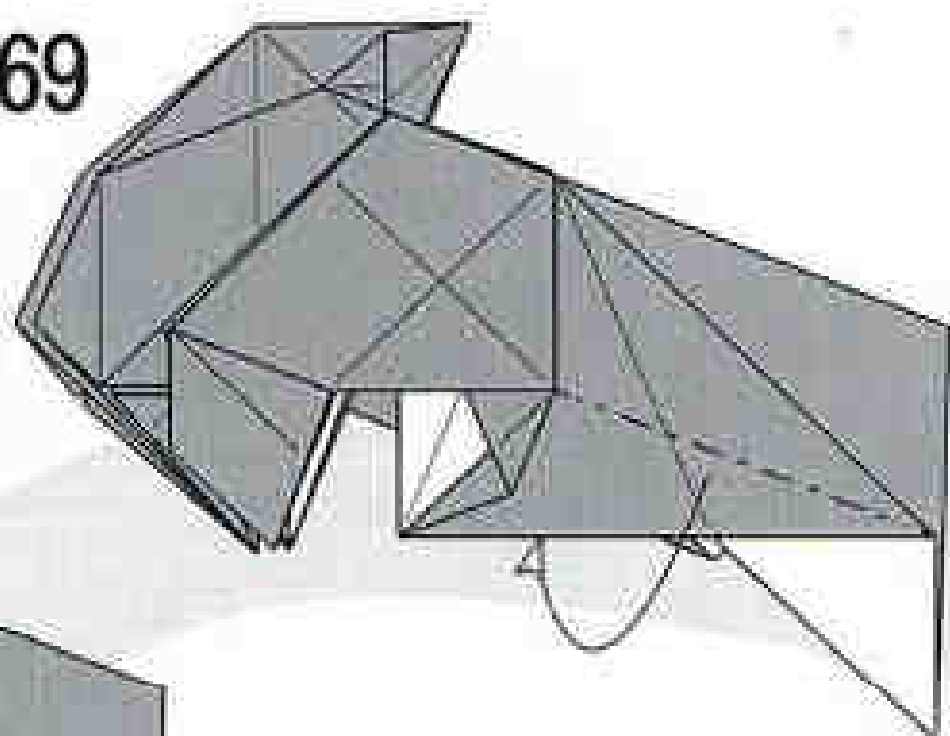

68

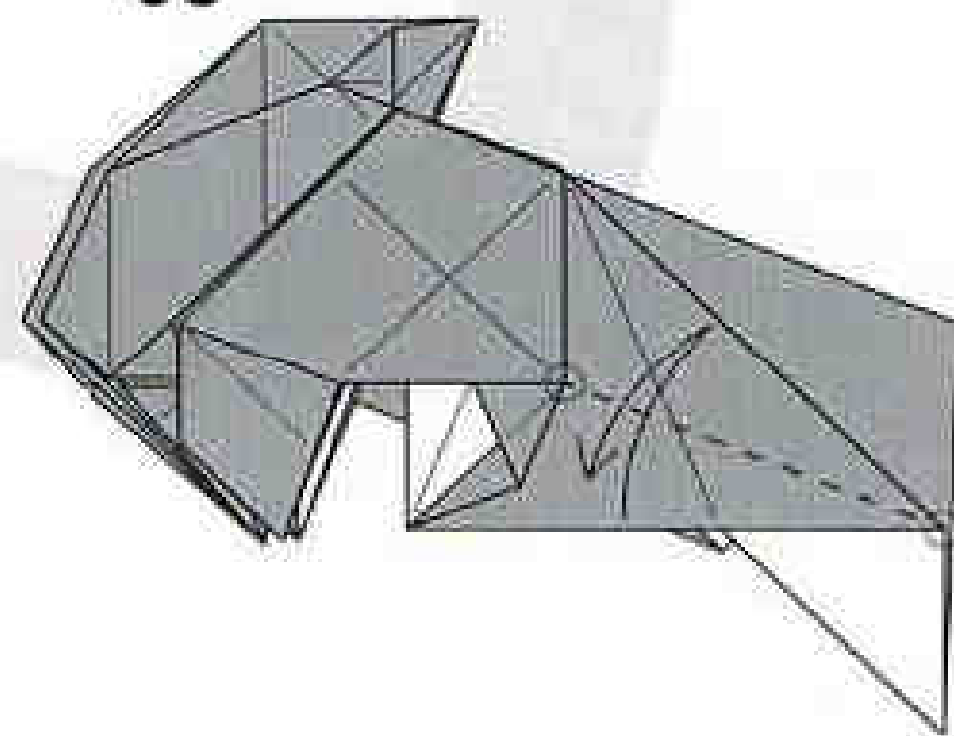

70

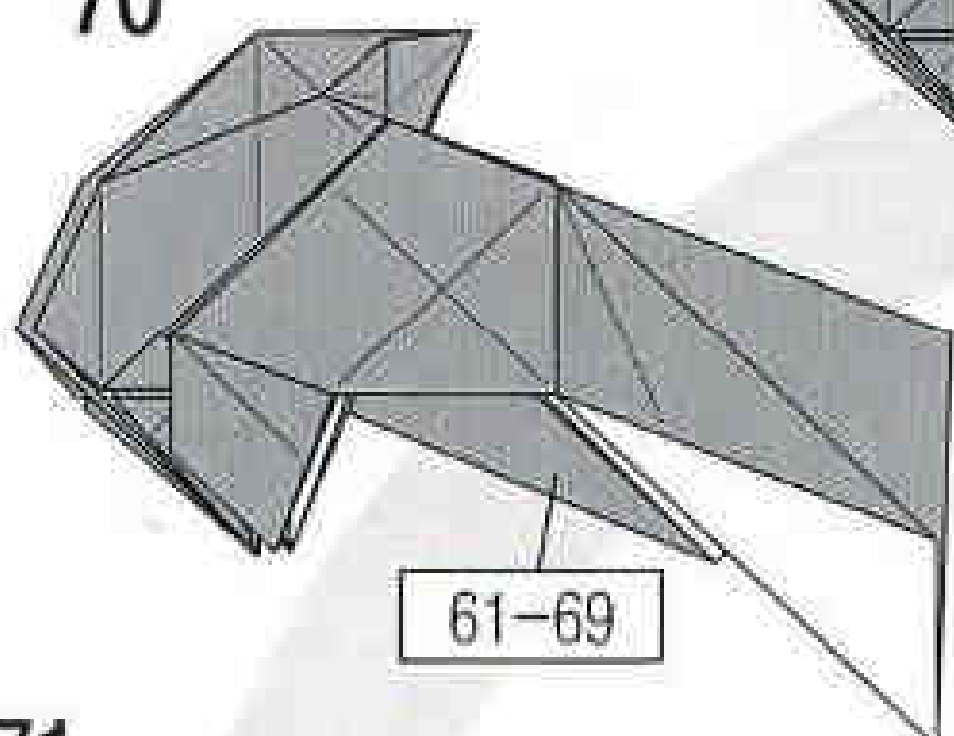

61-69

71

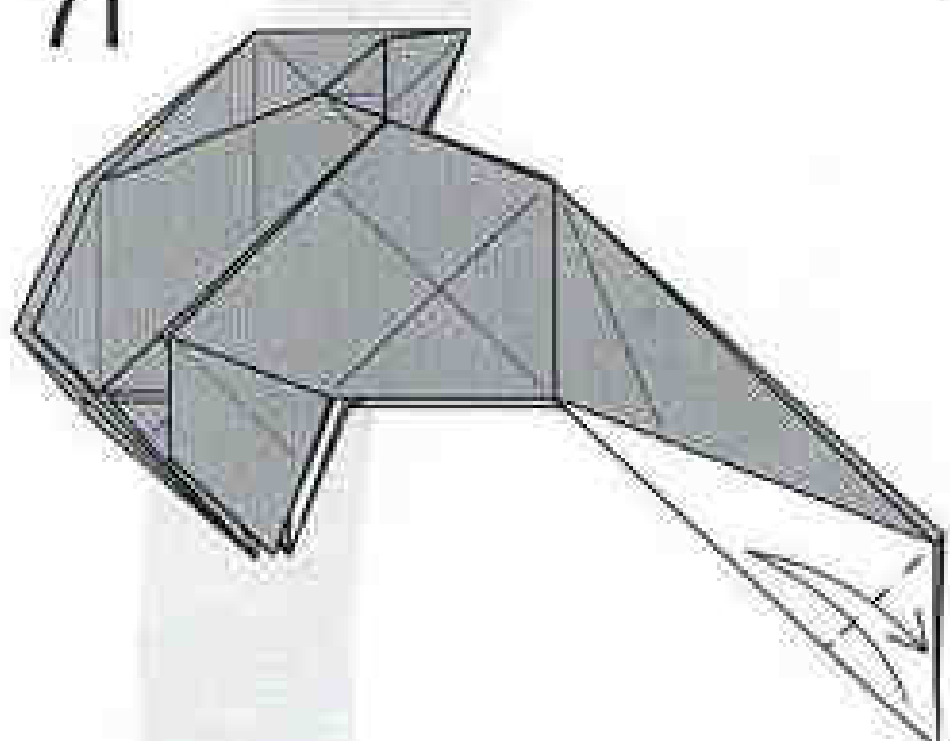

75

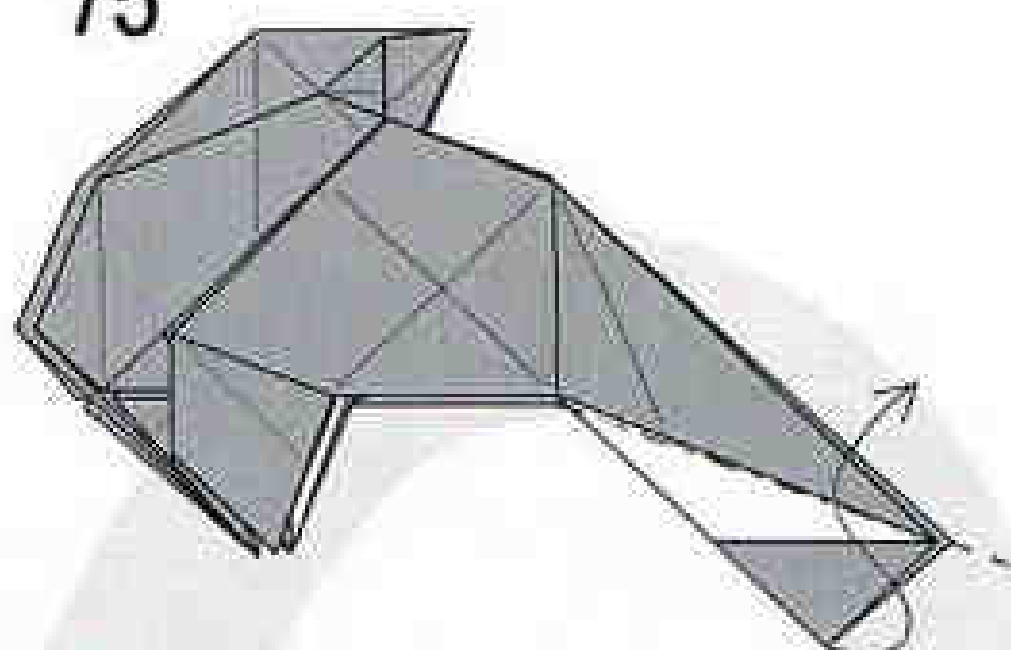

72

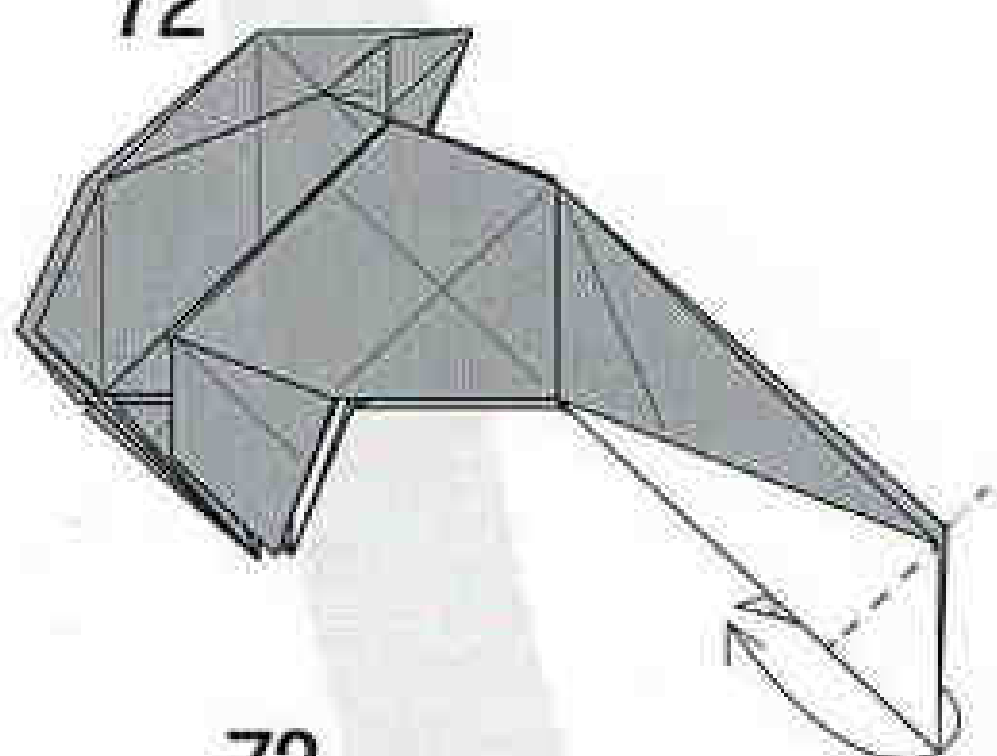

74

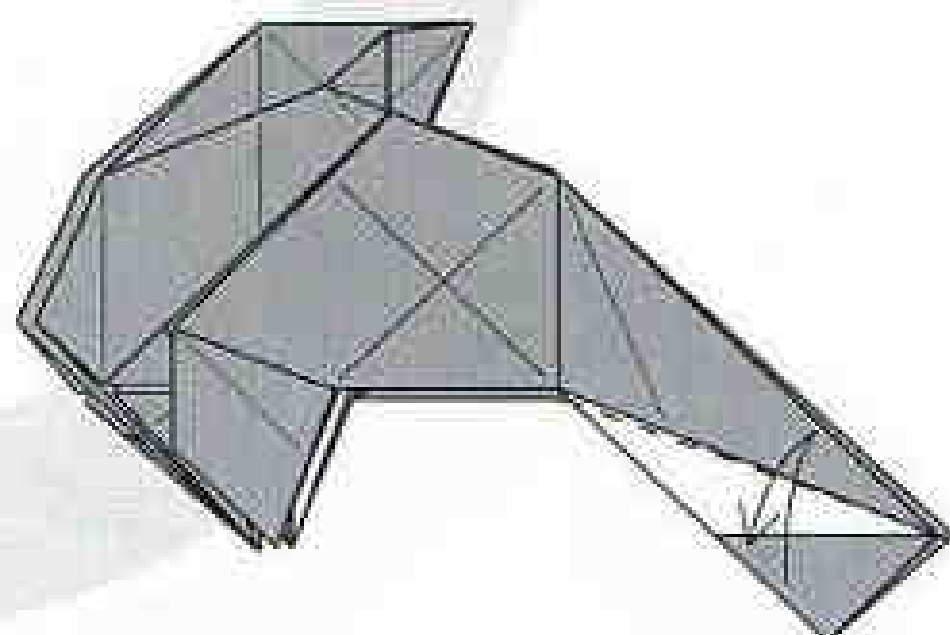

76

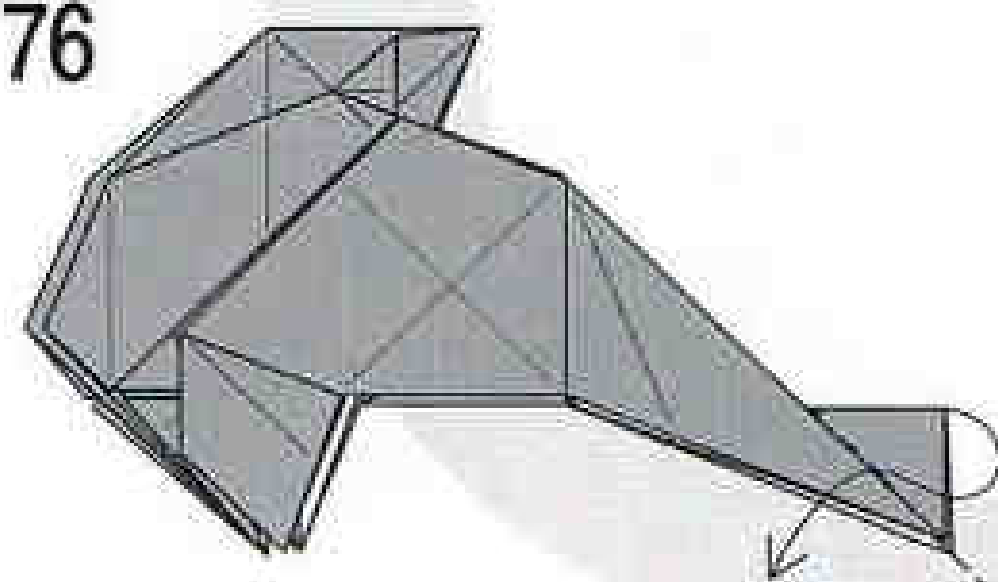

73

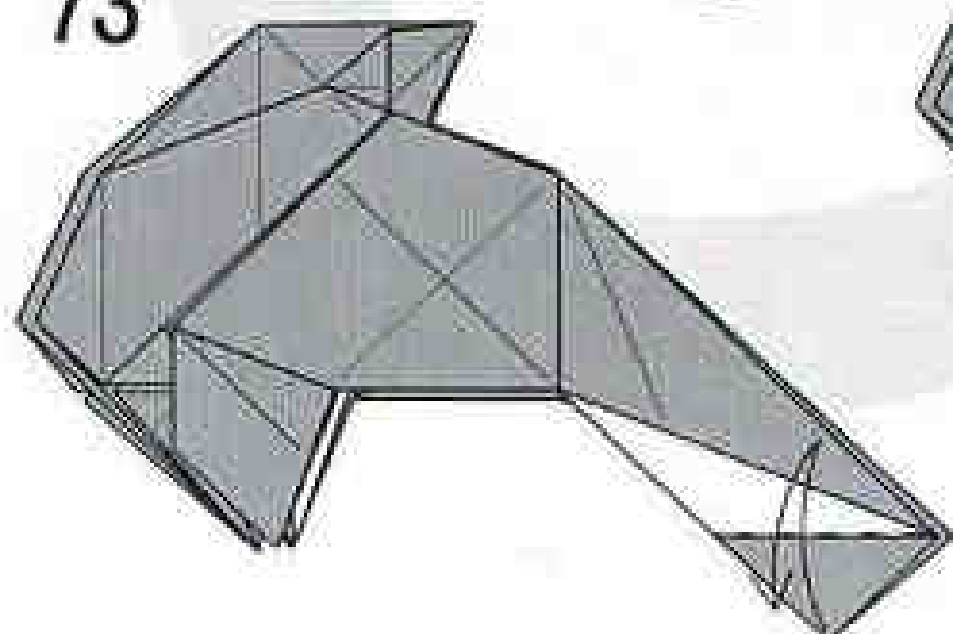

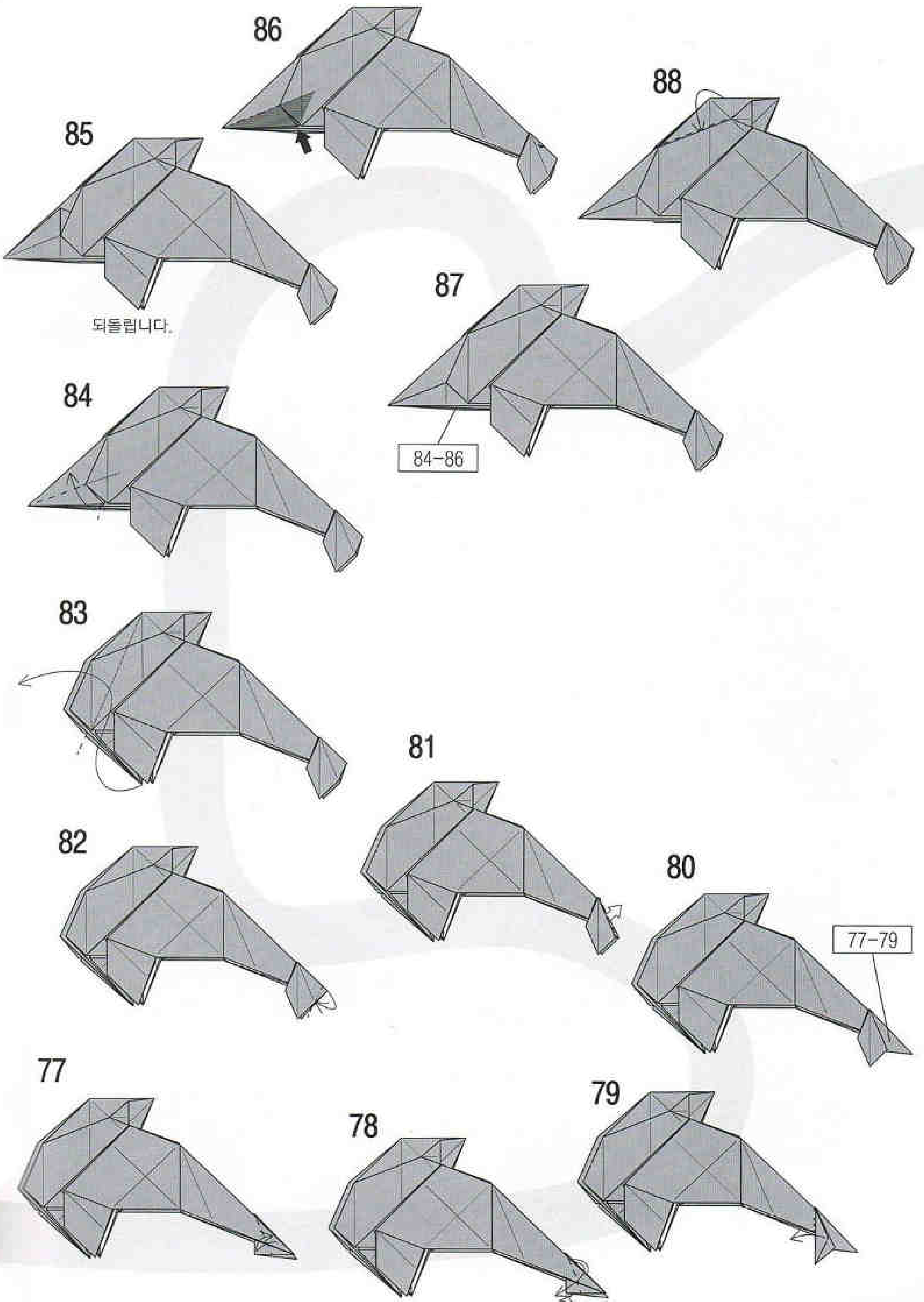

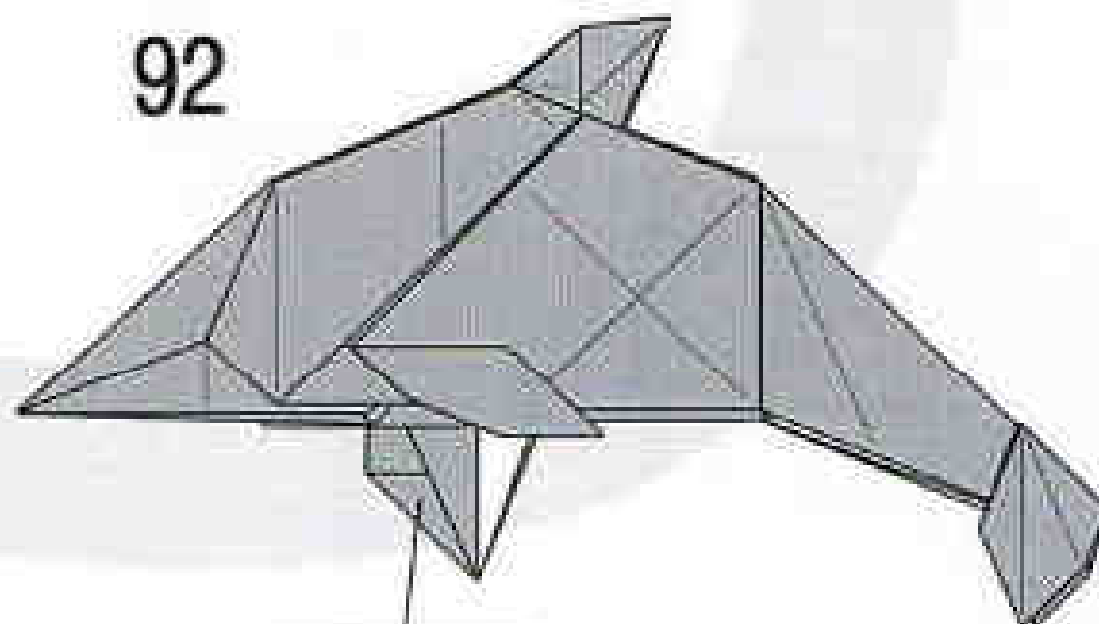
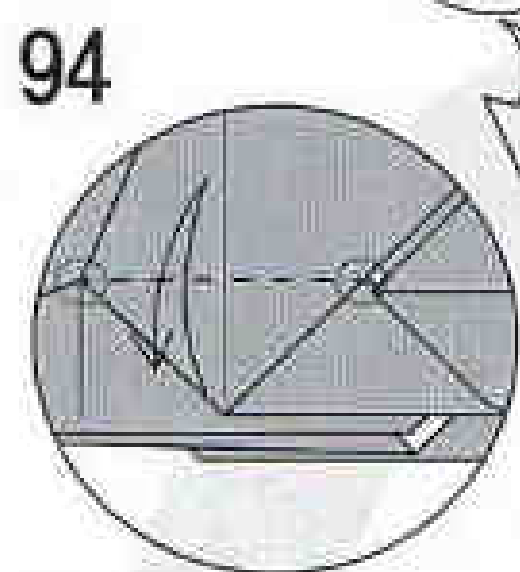
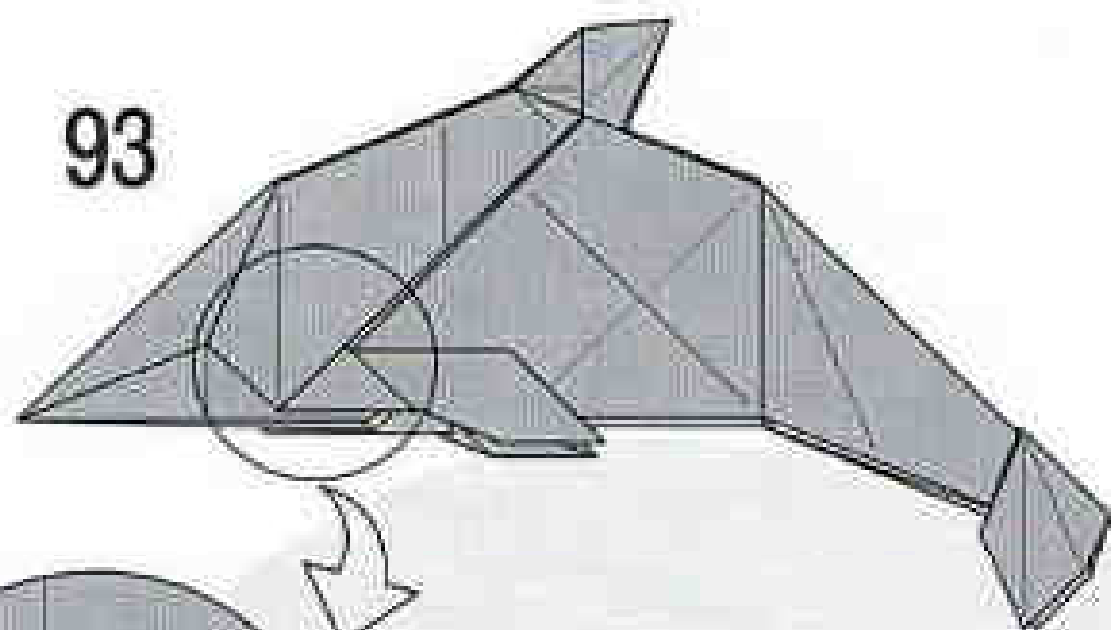
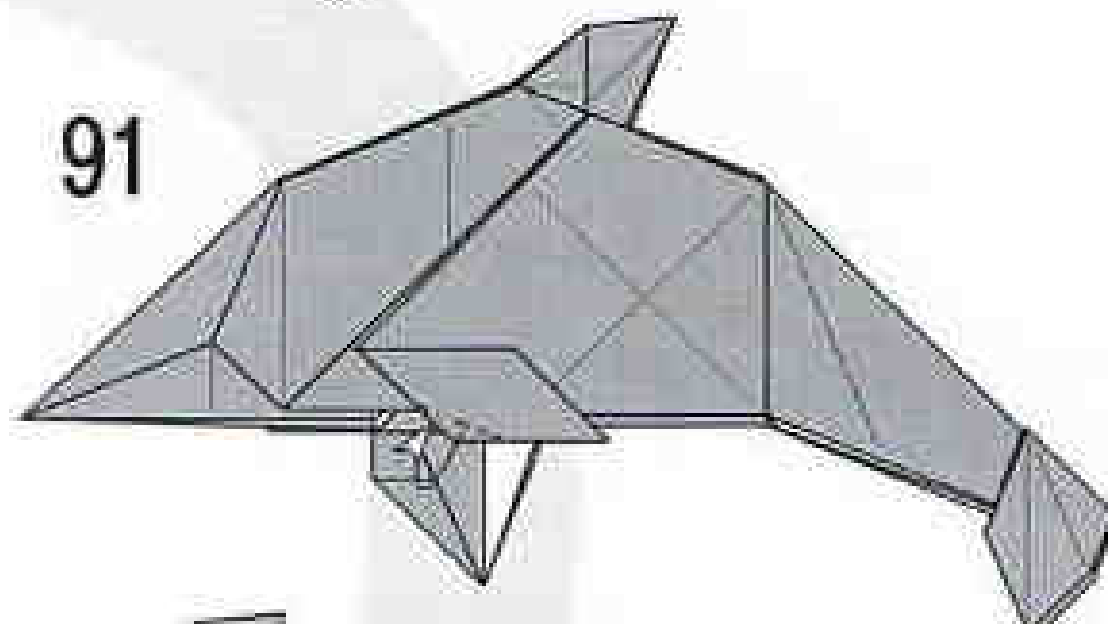
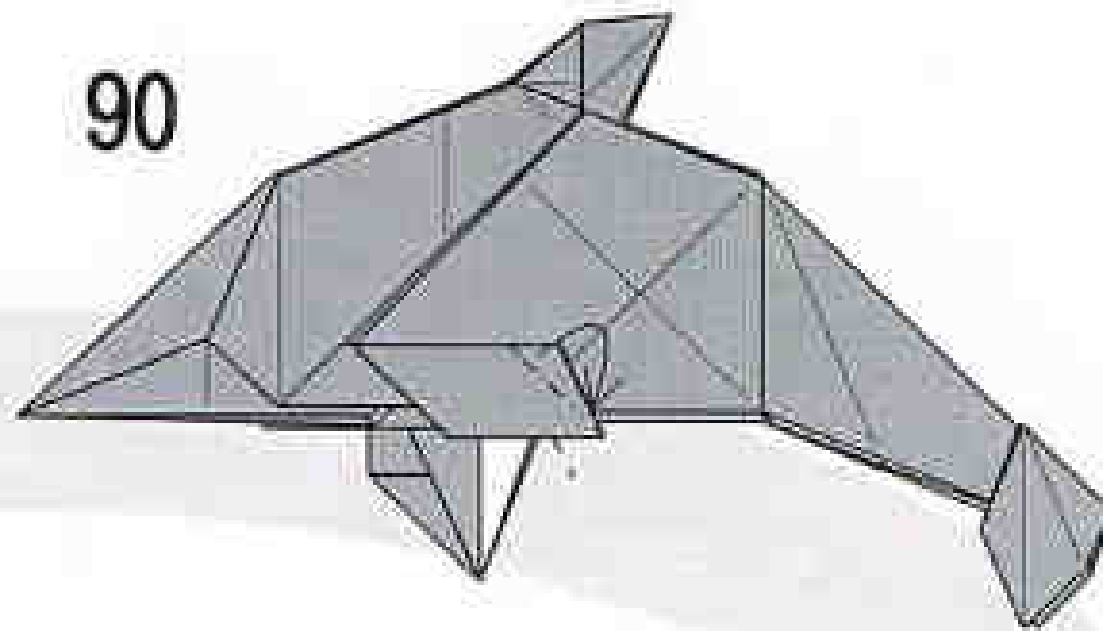
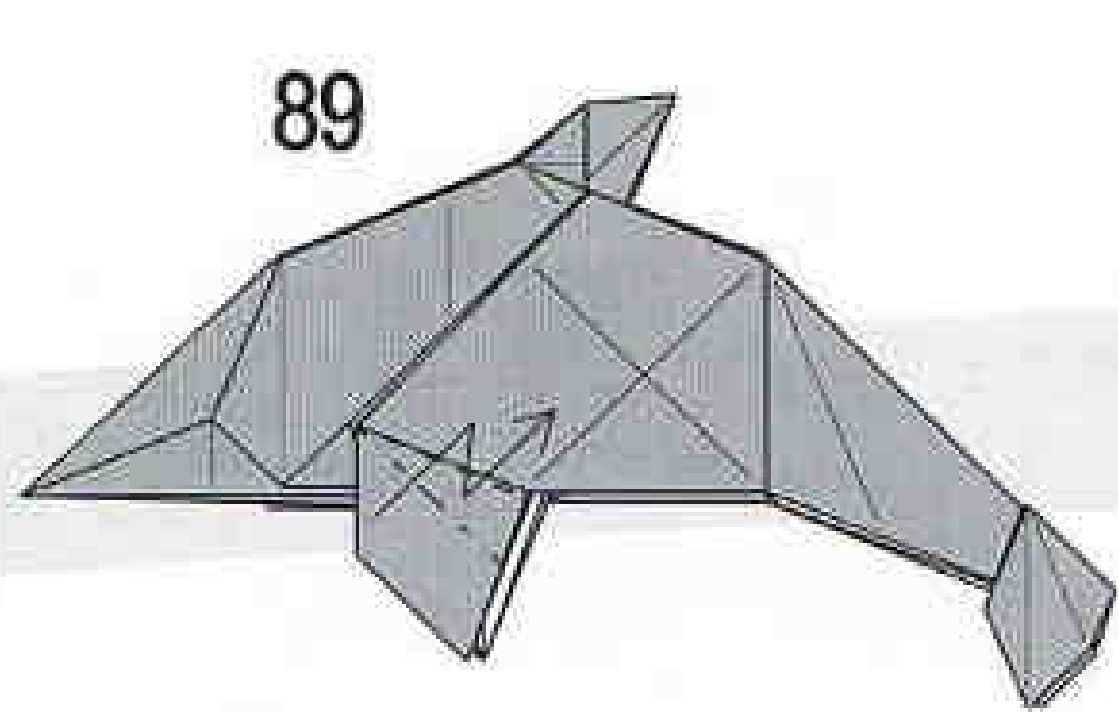

89-91

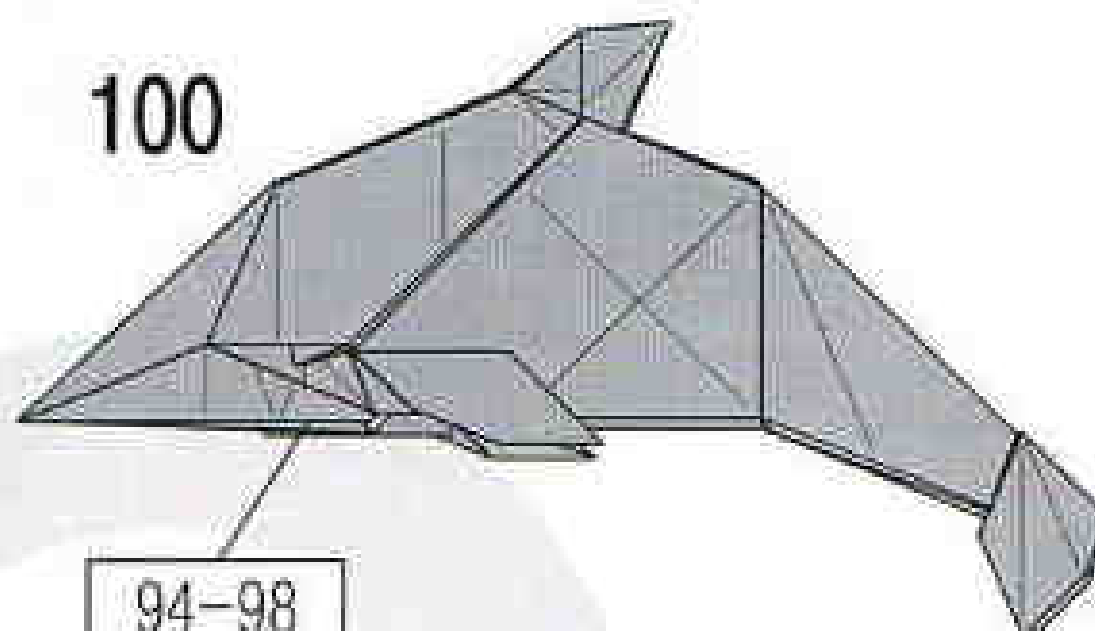
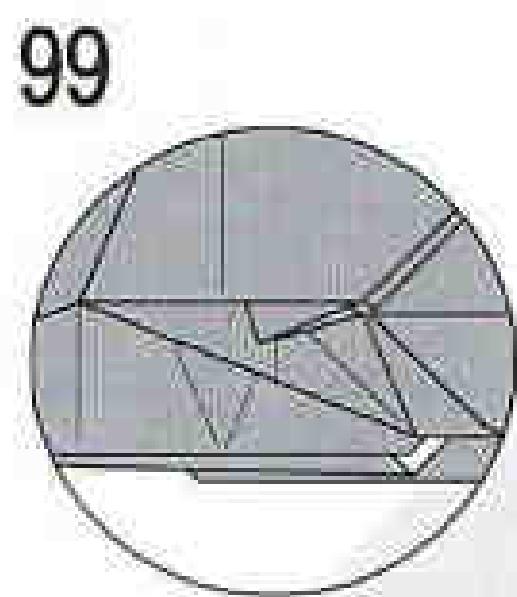
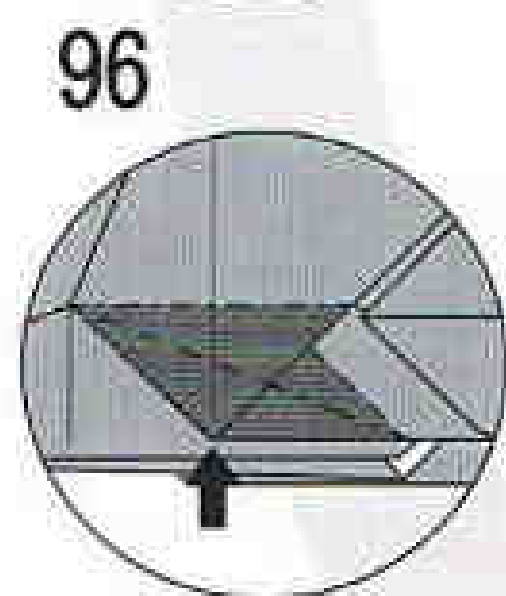
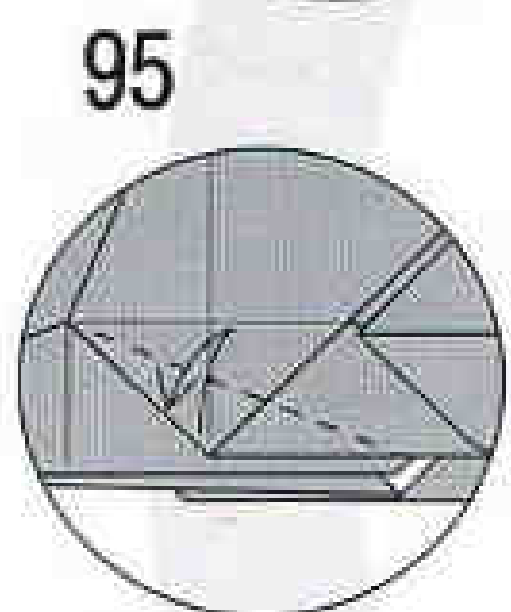

94-98

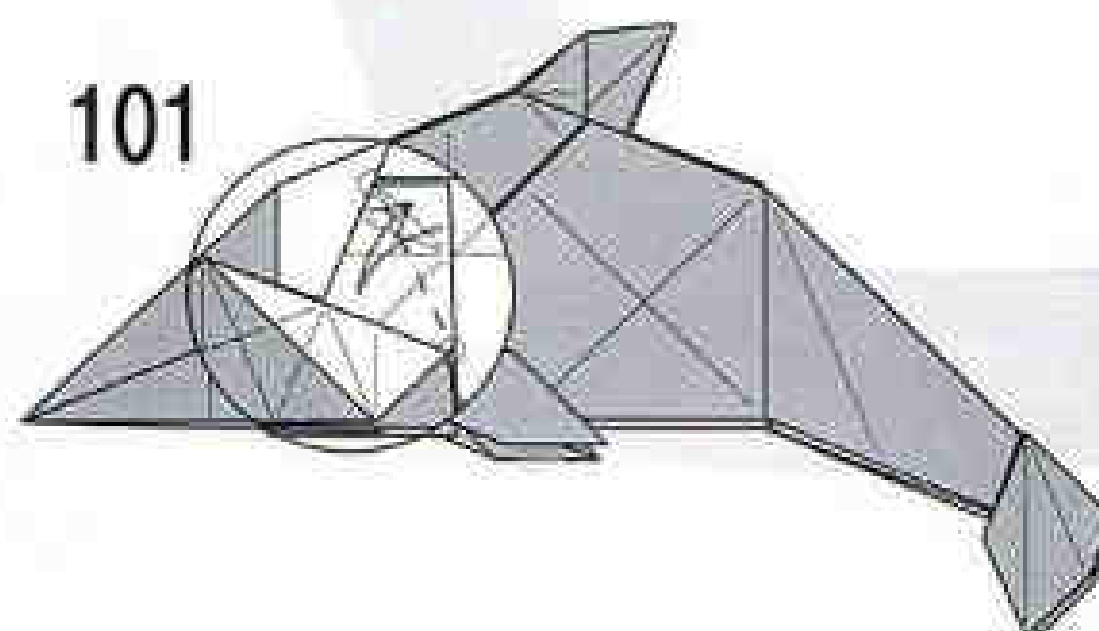
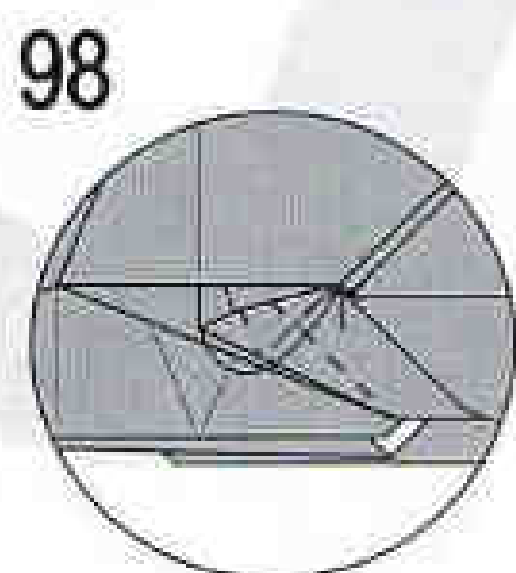
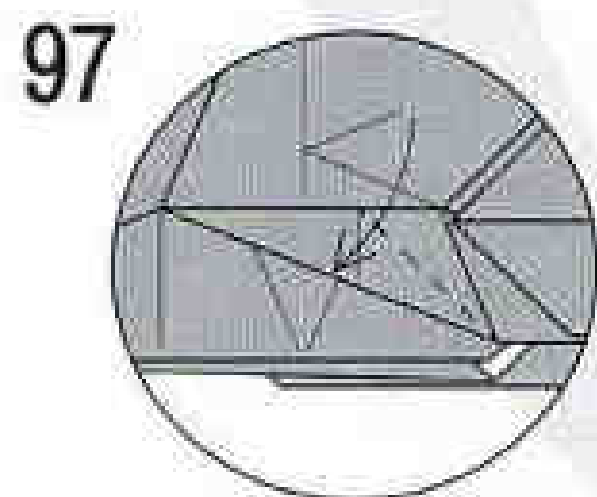

109

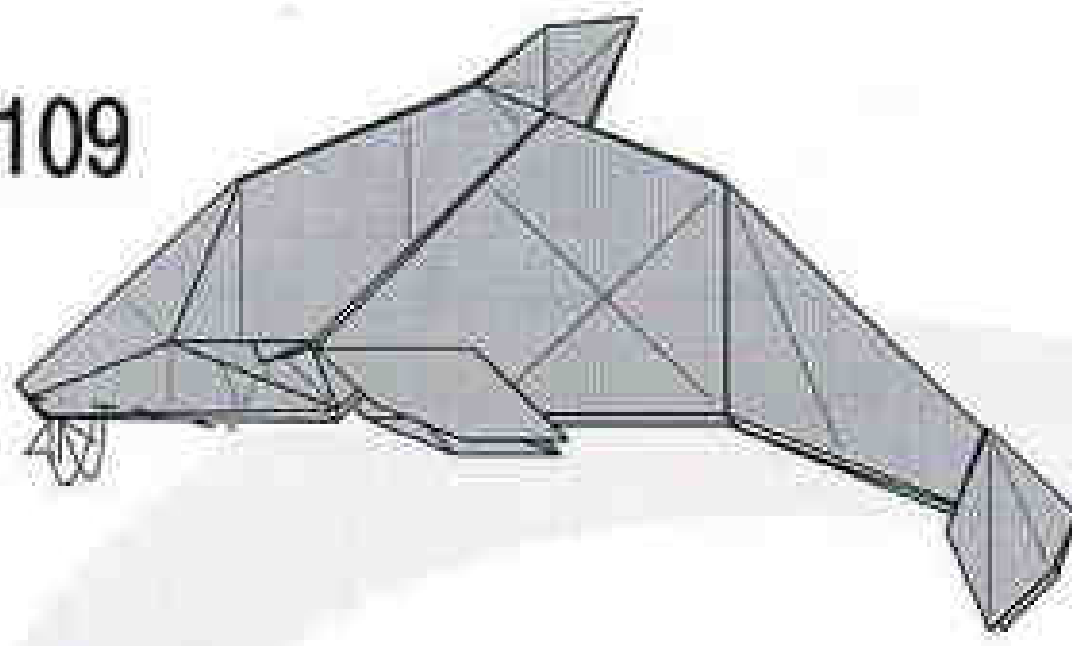

108

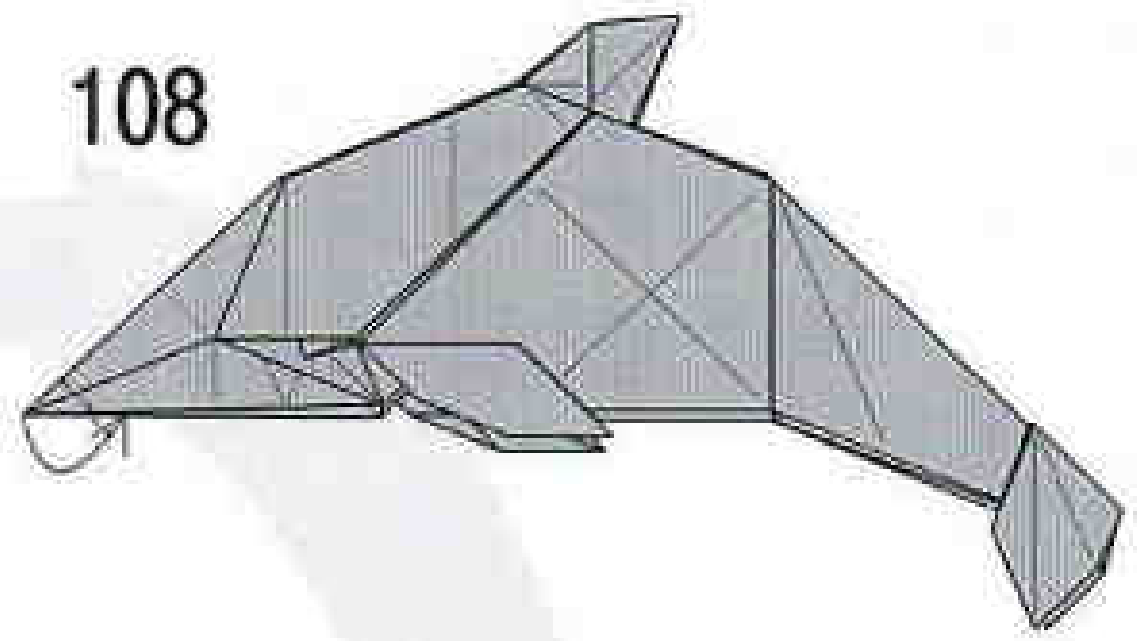

110

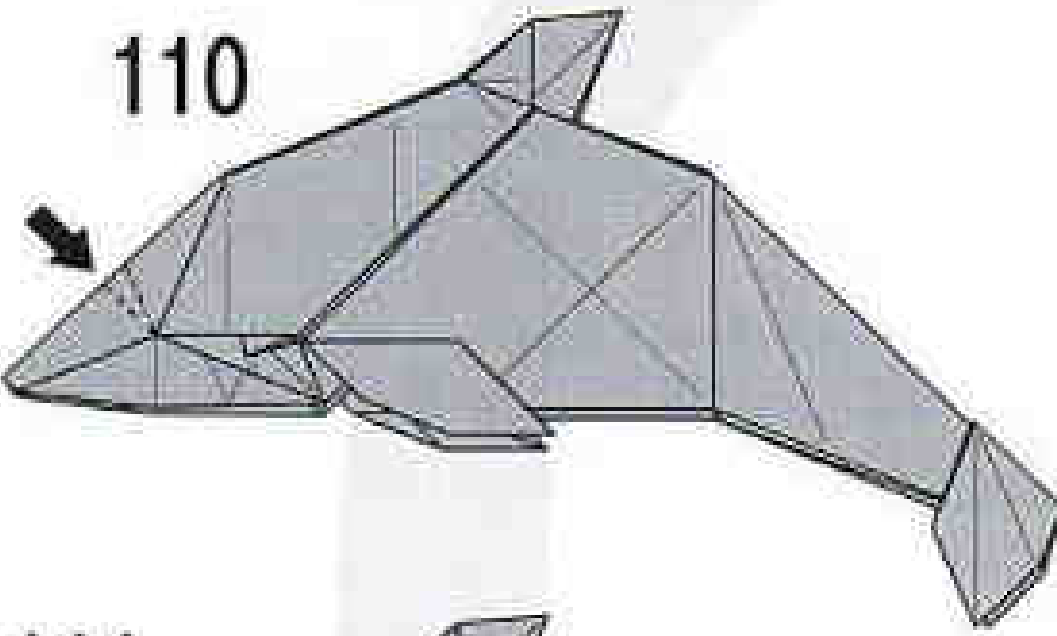

107

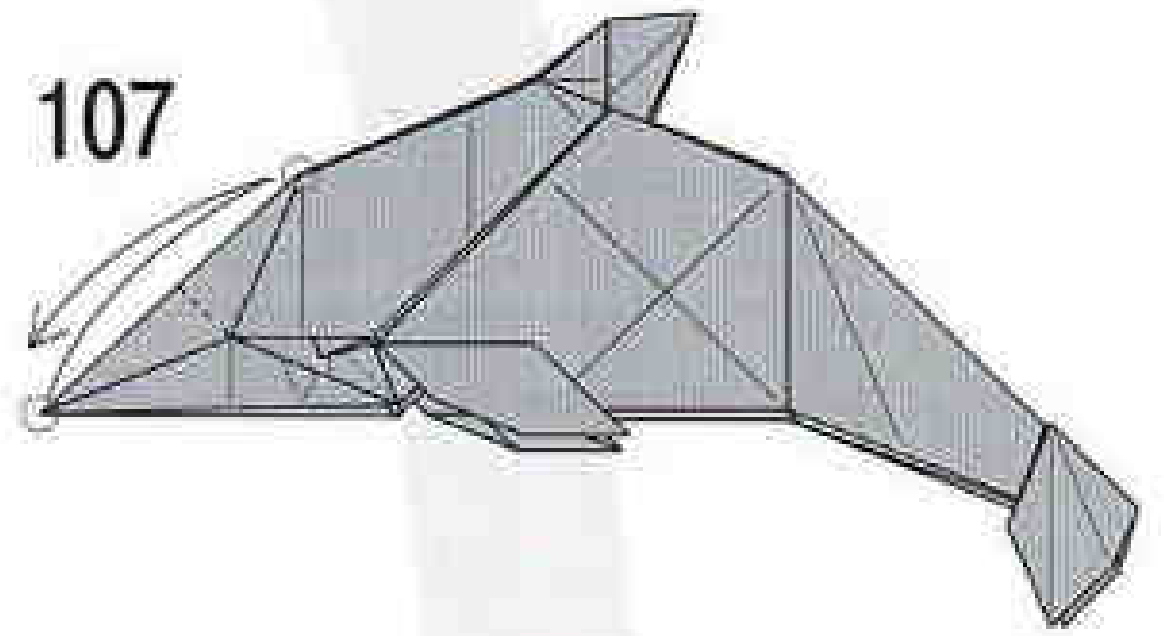

111

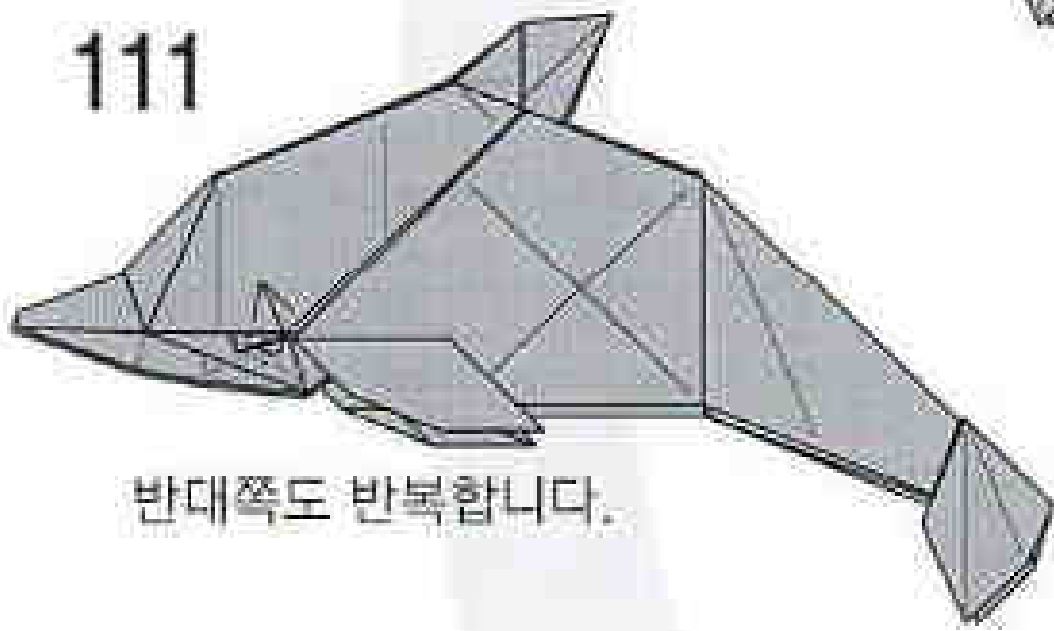

반대쪽도 반복합니다.

106

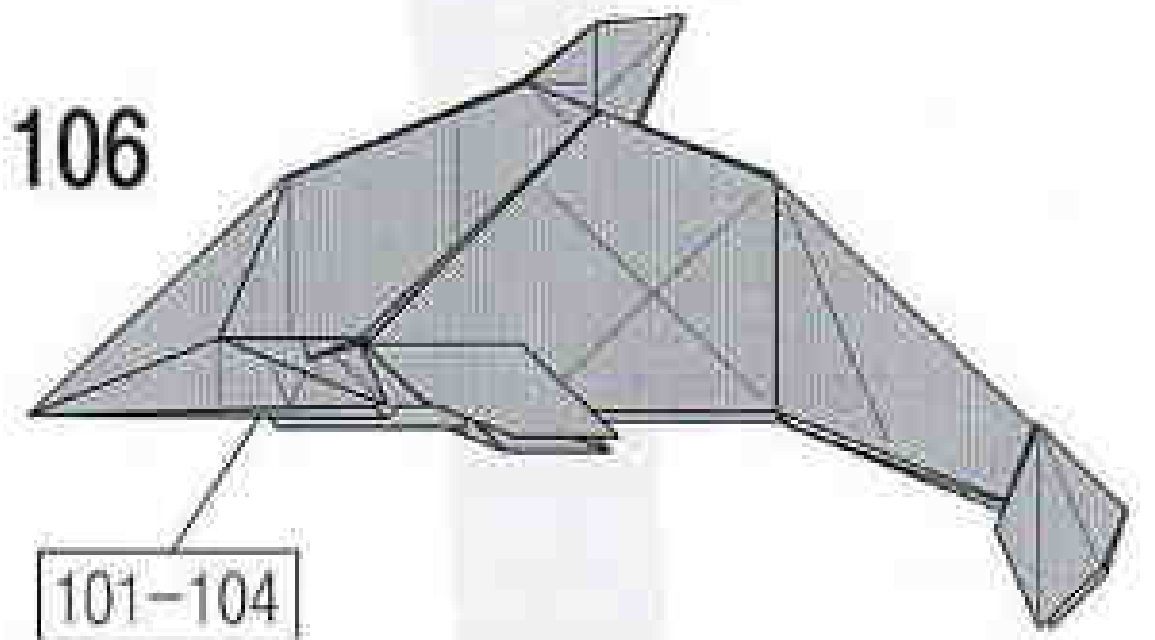

완성

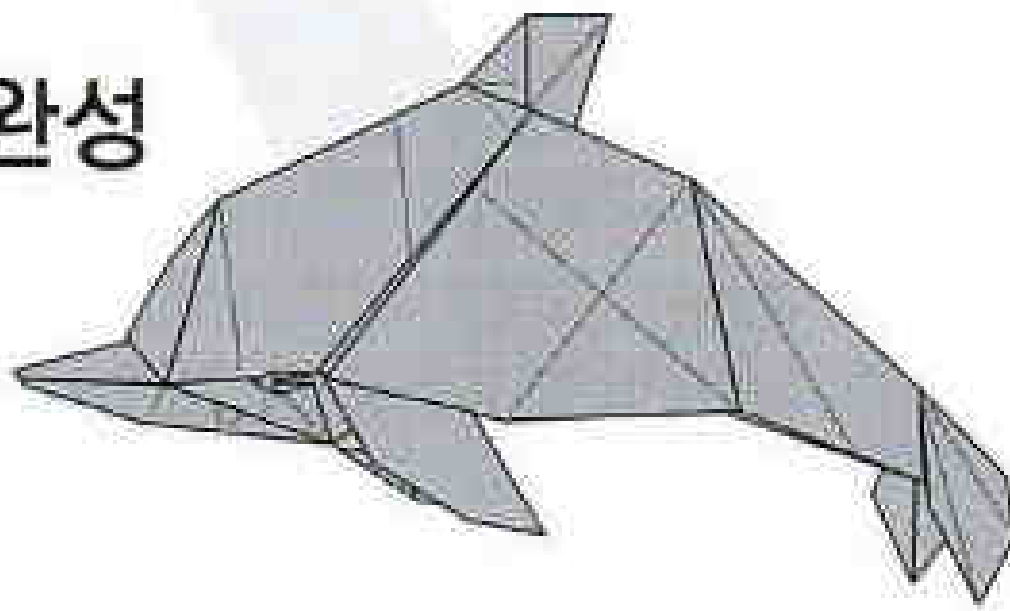

105

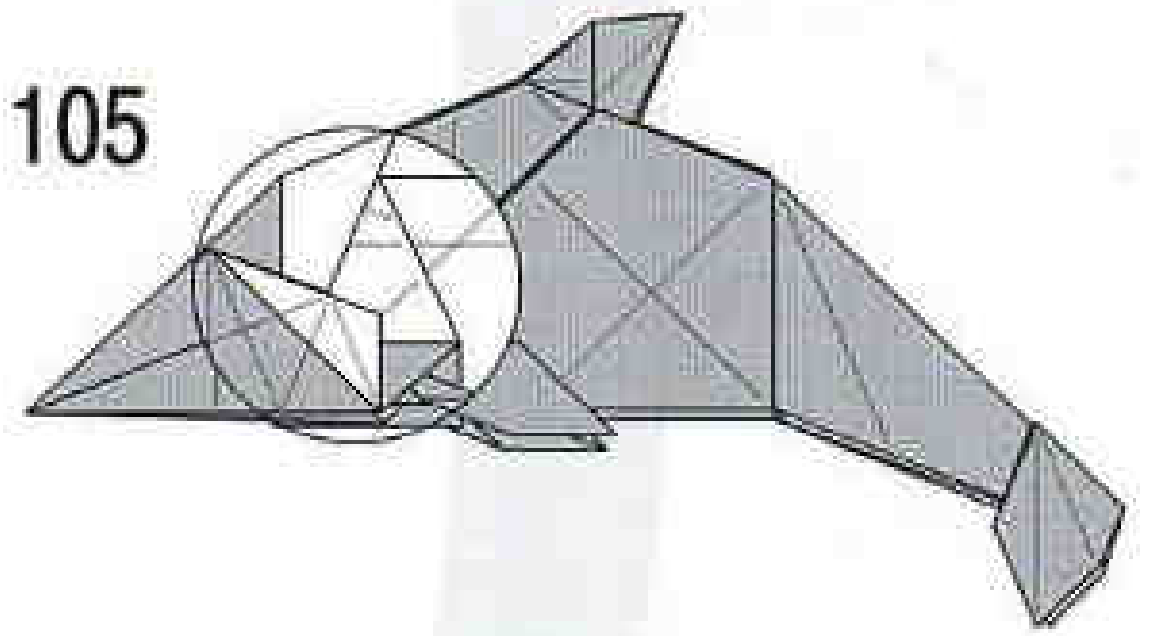

104

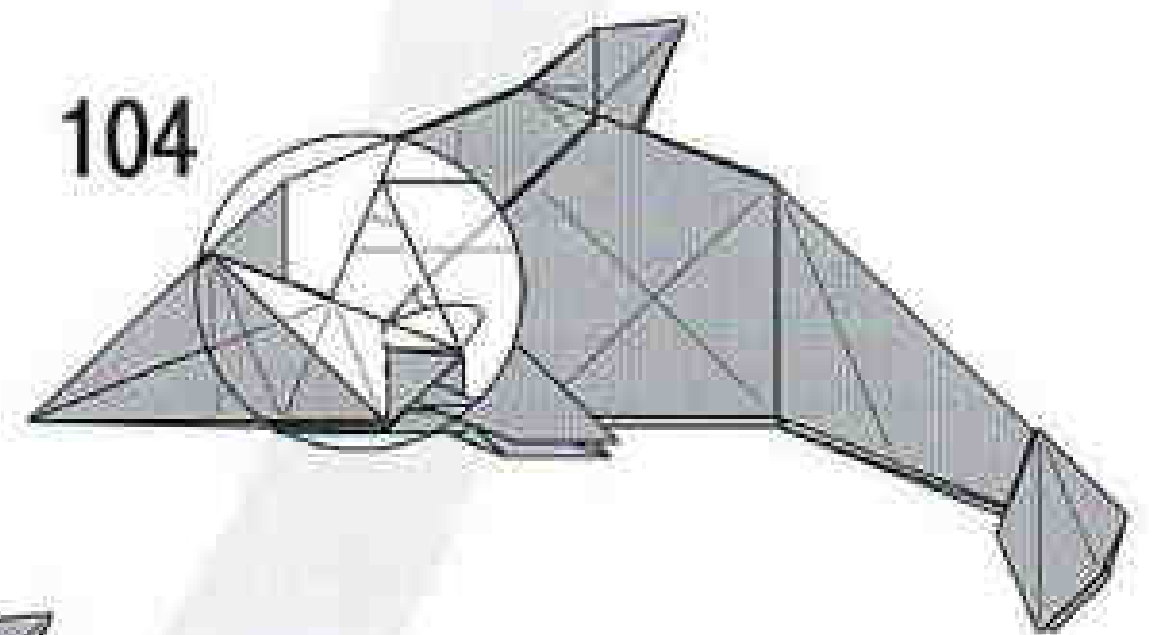

102

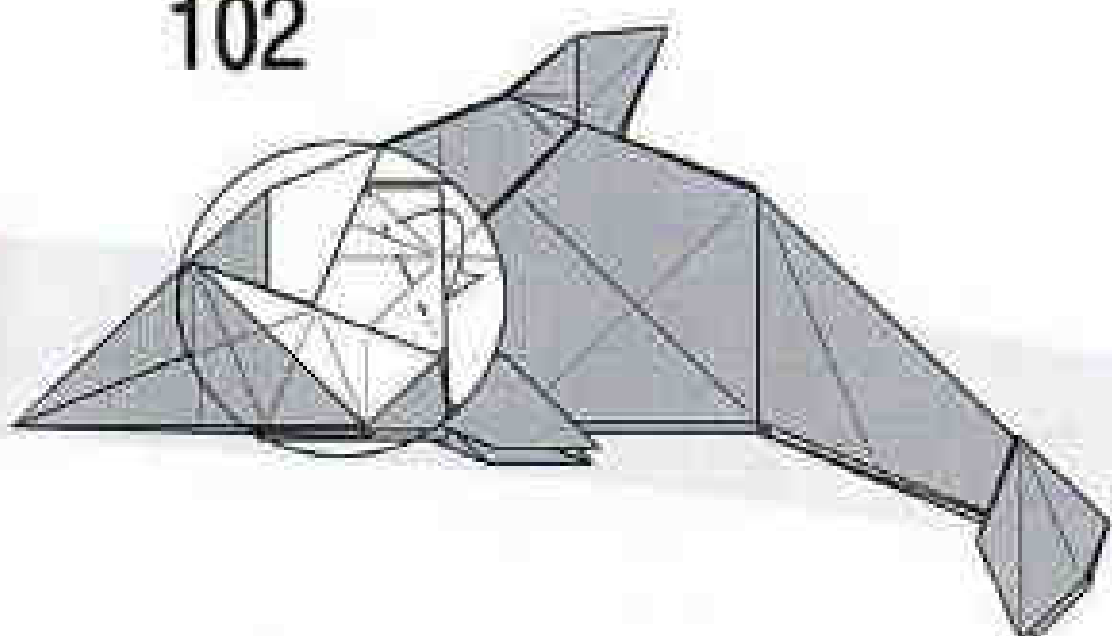

103

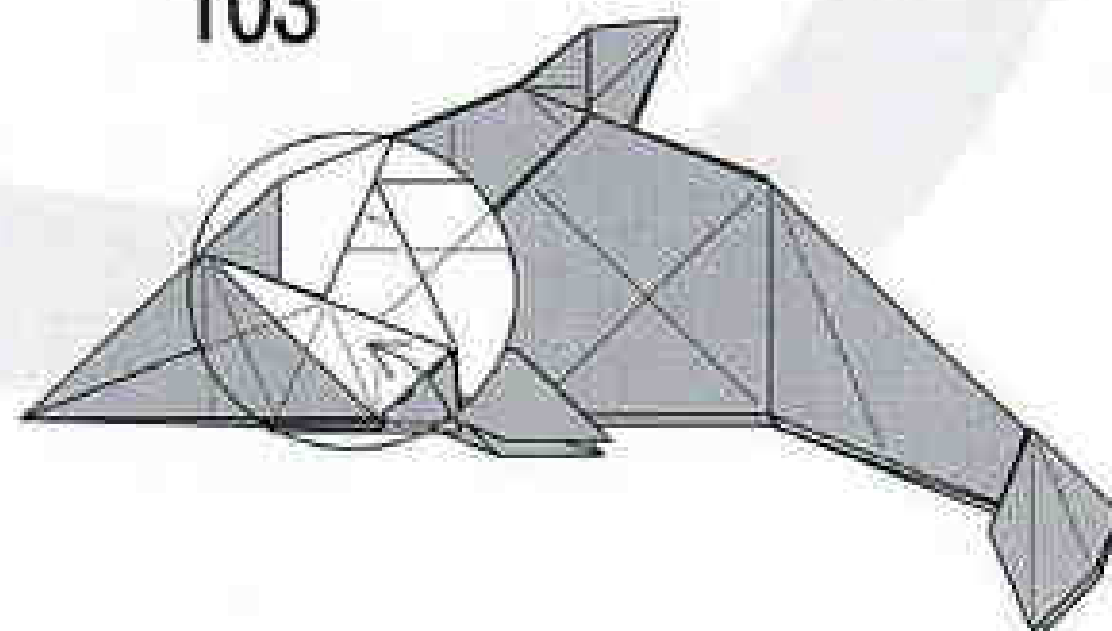

물개 (Fur Seal)

창작가 : 이인섭 (Lee In Seop)

다이어그램 : 유태용 (Yoo Tae Yong)

창작일 : 2015.06.30

종이크기 : 40cm x 40cm

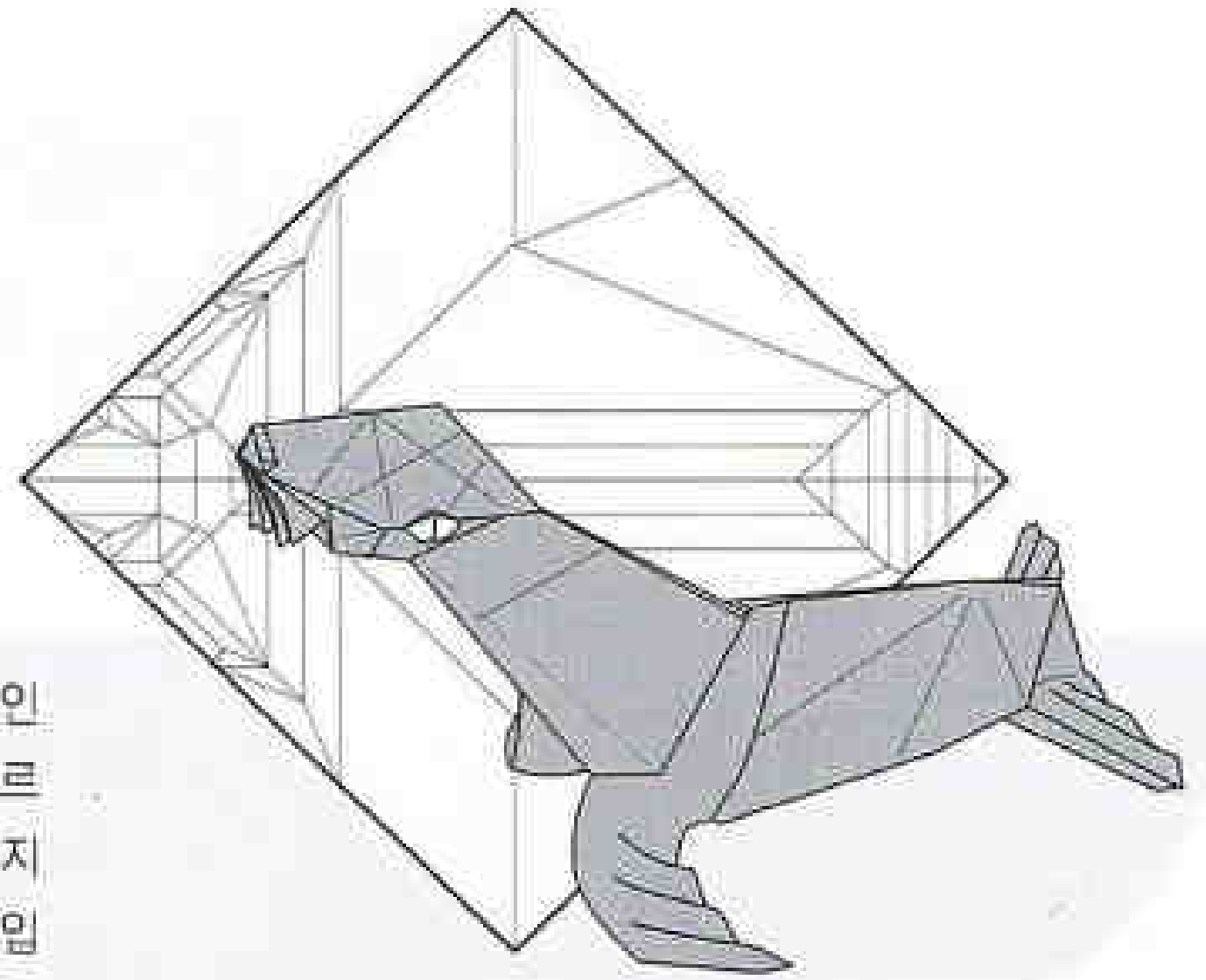

물개의 사진을 봤을때 가장 먼저 눈에 들어온 것은 수영이었습니다. 눈은 인사이드 아웃으로 표현하고 수영에 표현을 집중하여 종이 가운데를 가로지르는 여분을 얼굴에 투자하였습니다. 결과적으로 조금 아쉬운 얼굴이 되었지만 몸통에서 예상외의 관참은 조형감이 나와서 다행인 작품입니다. 목이 입체지만 살짝 꺾어 자연스럽게 표현하는 것도 관참은 마무리 방법입니다.

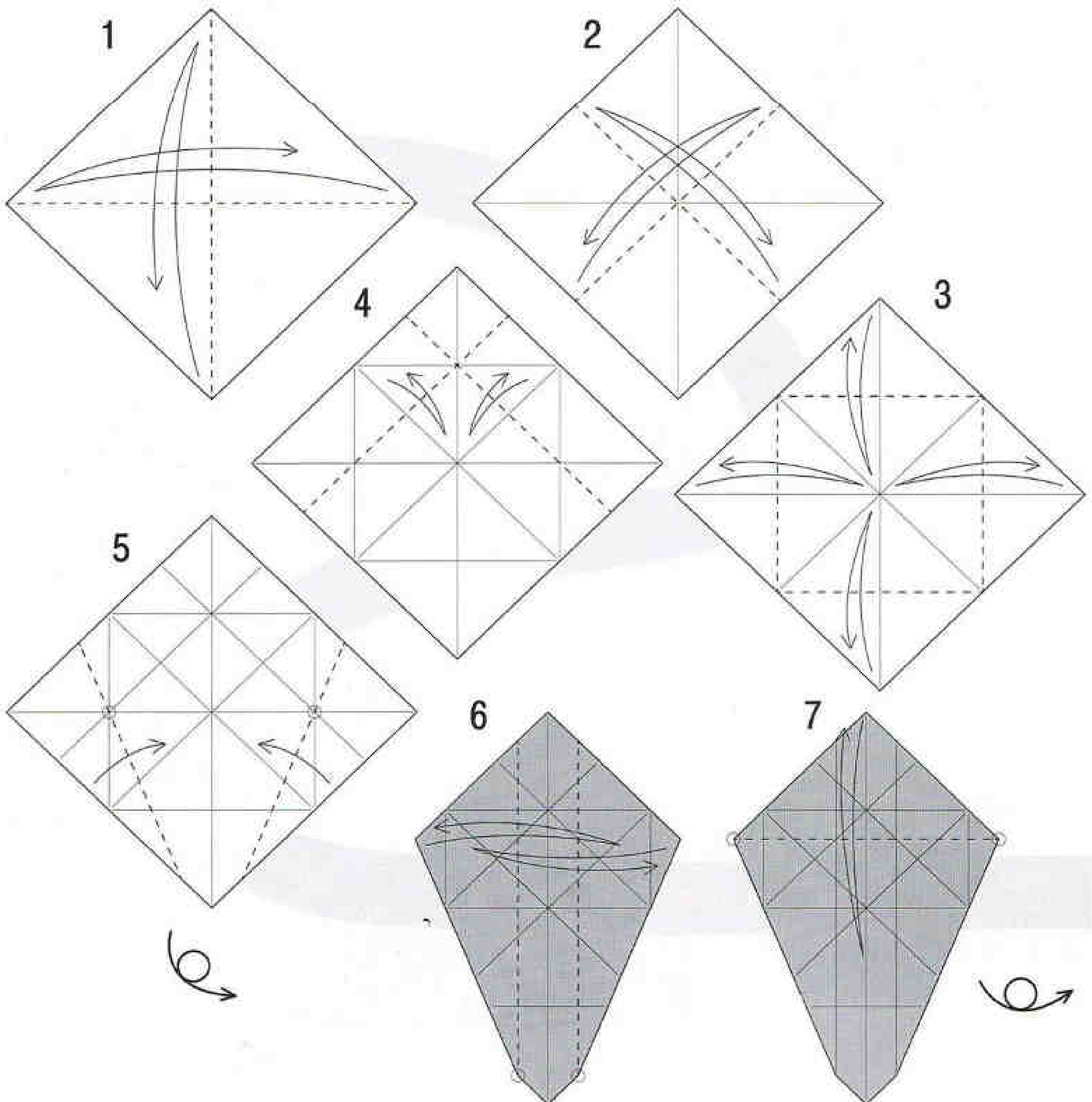

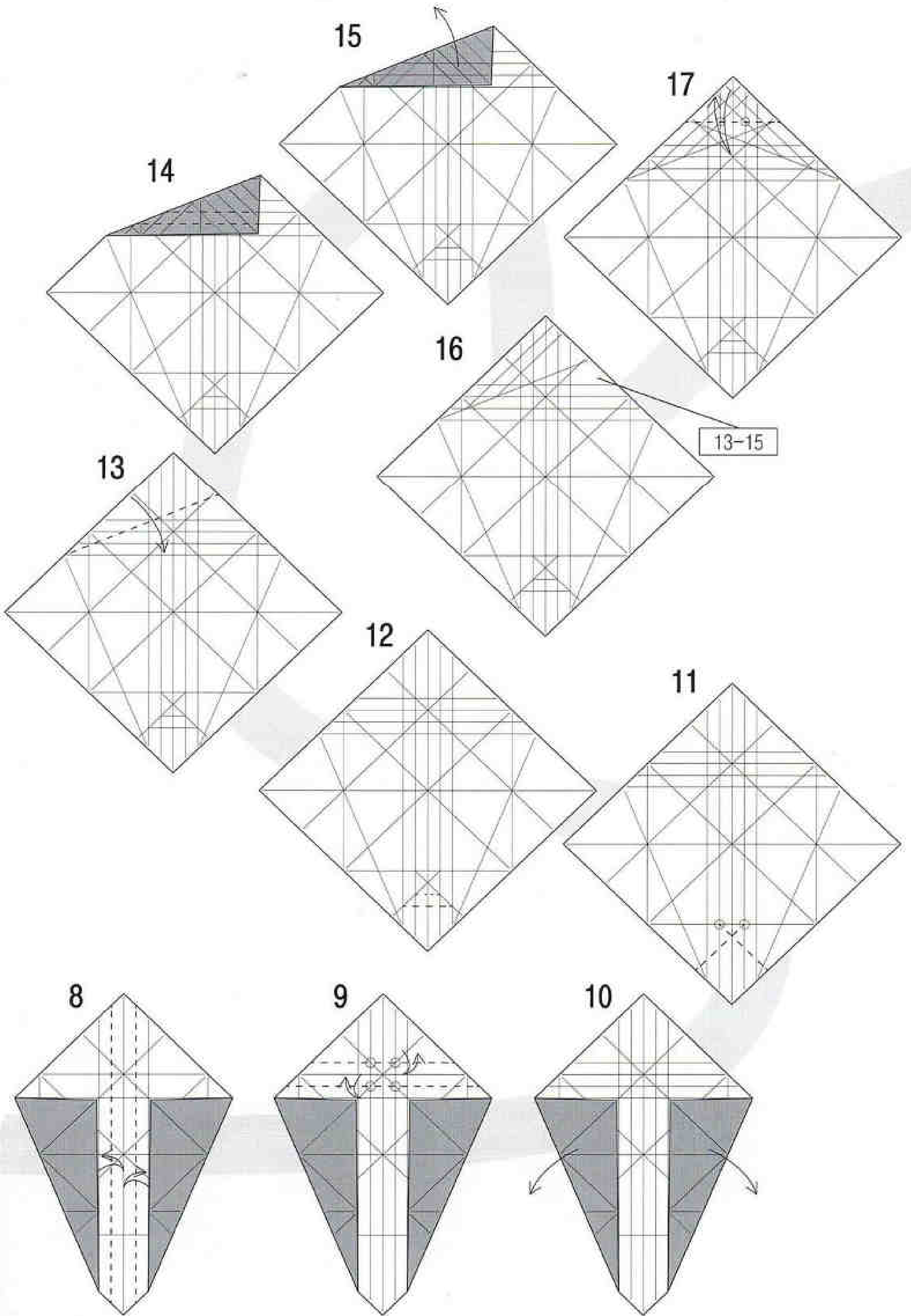

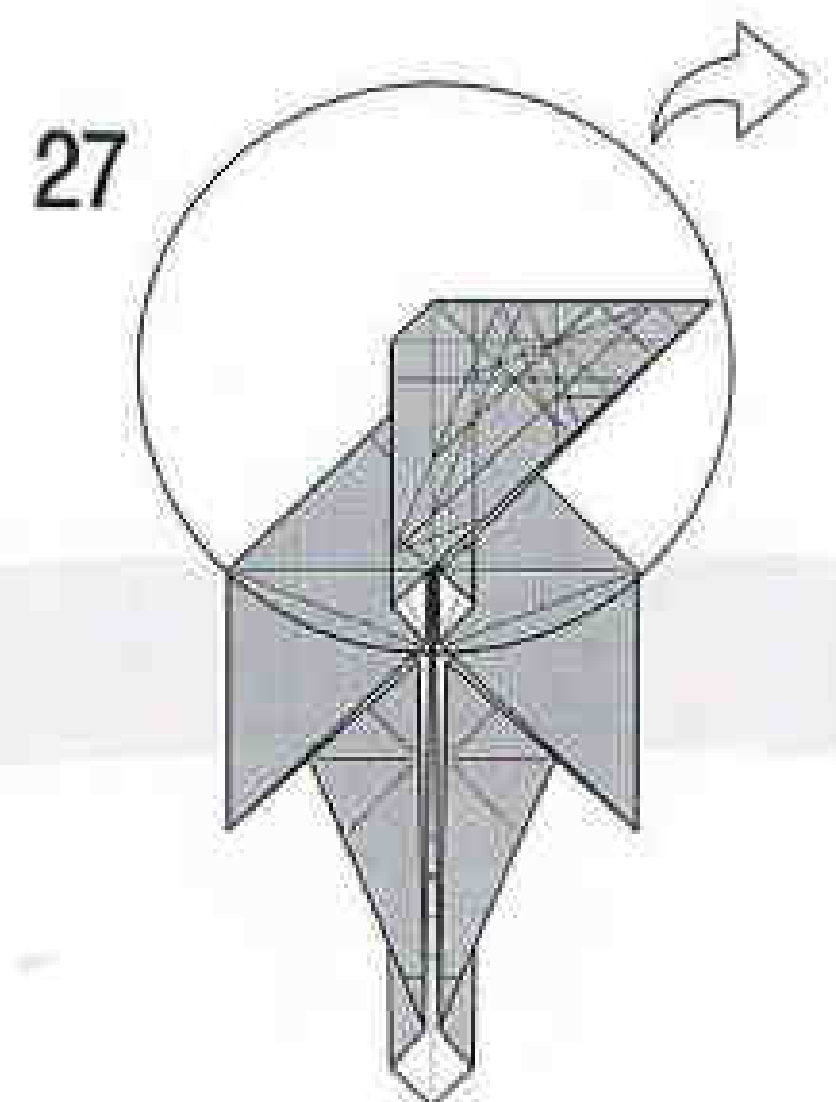
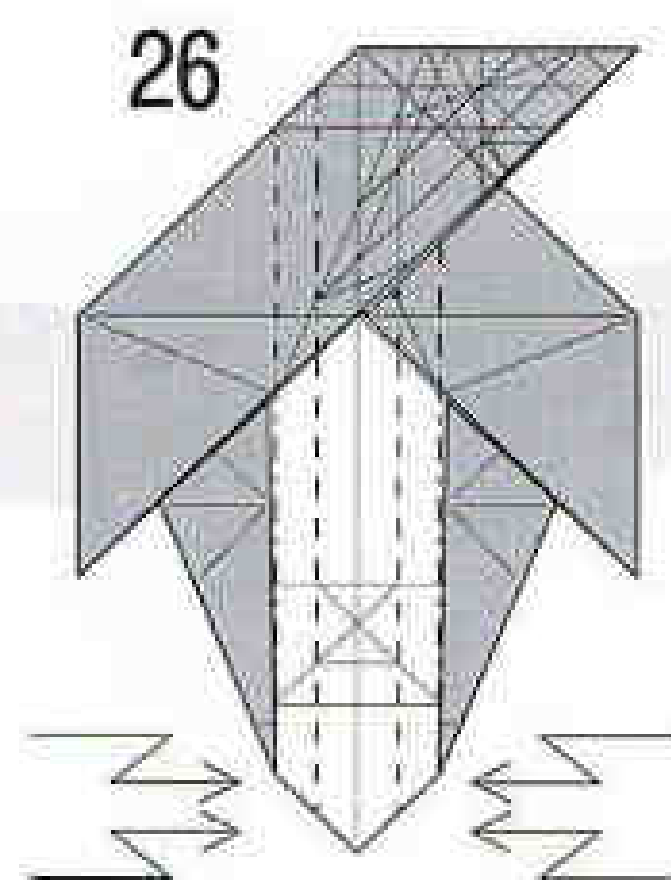
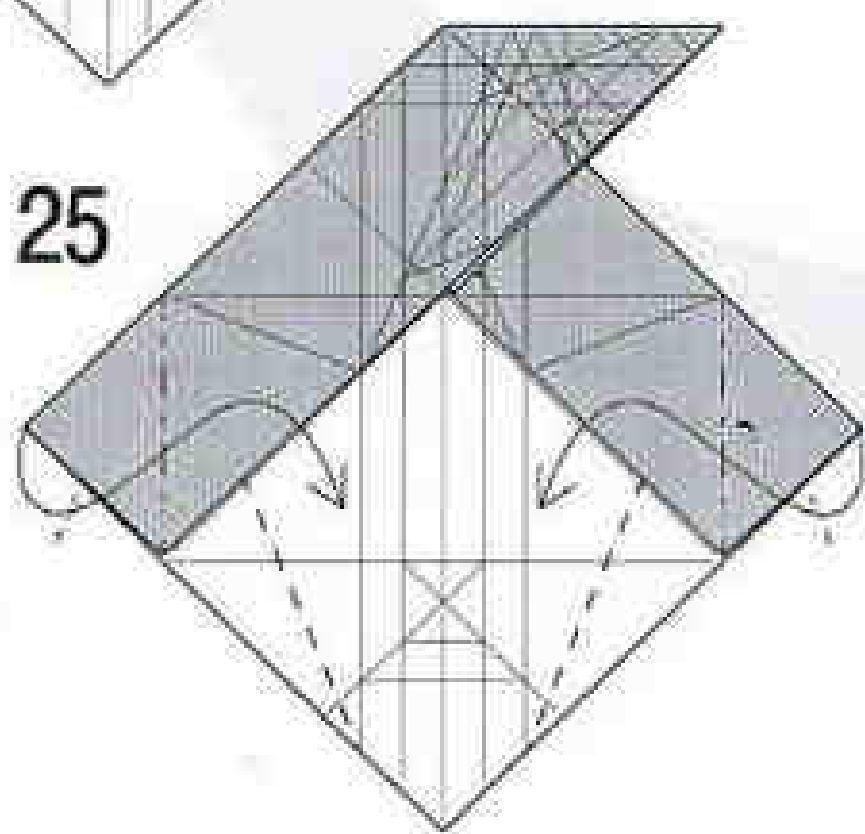
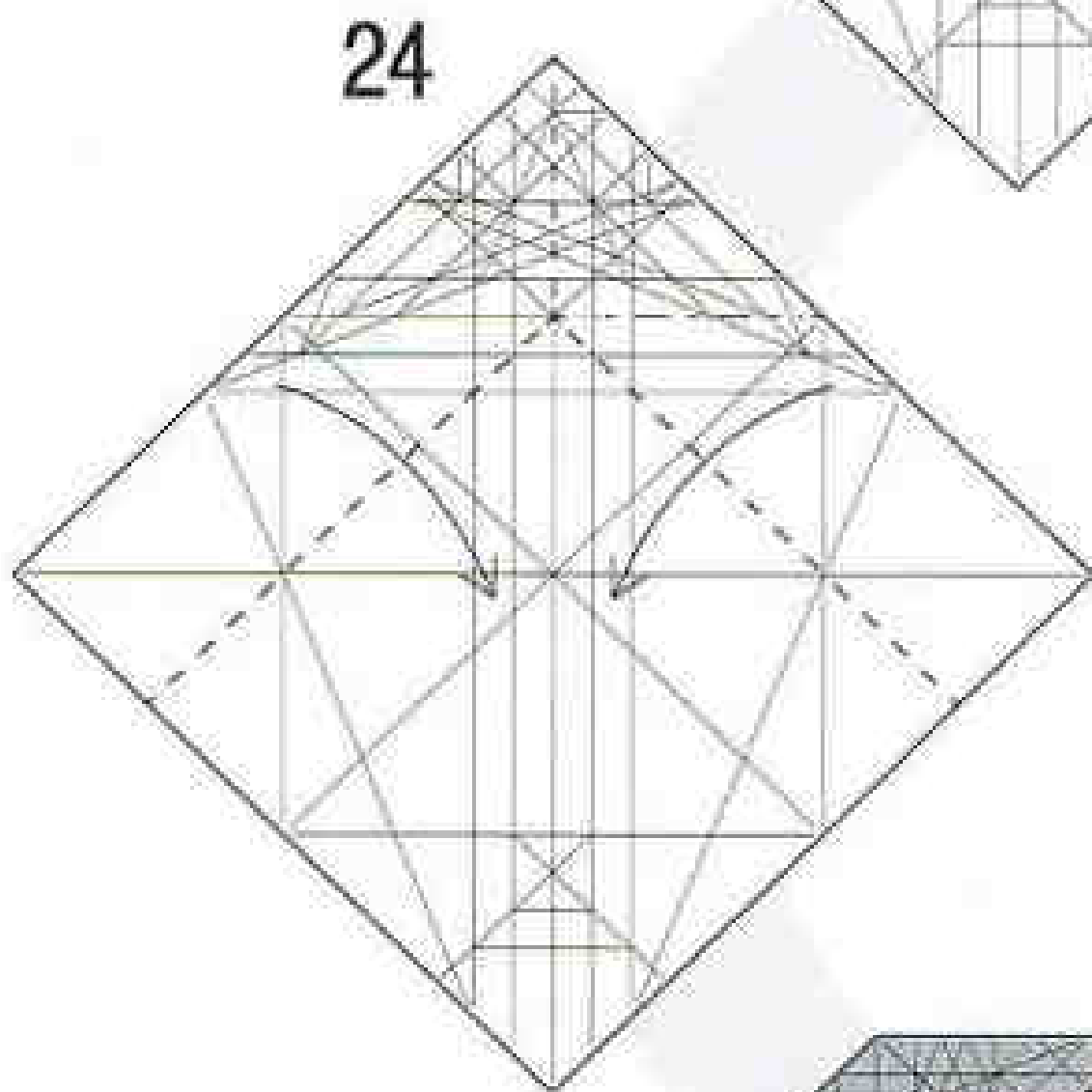
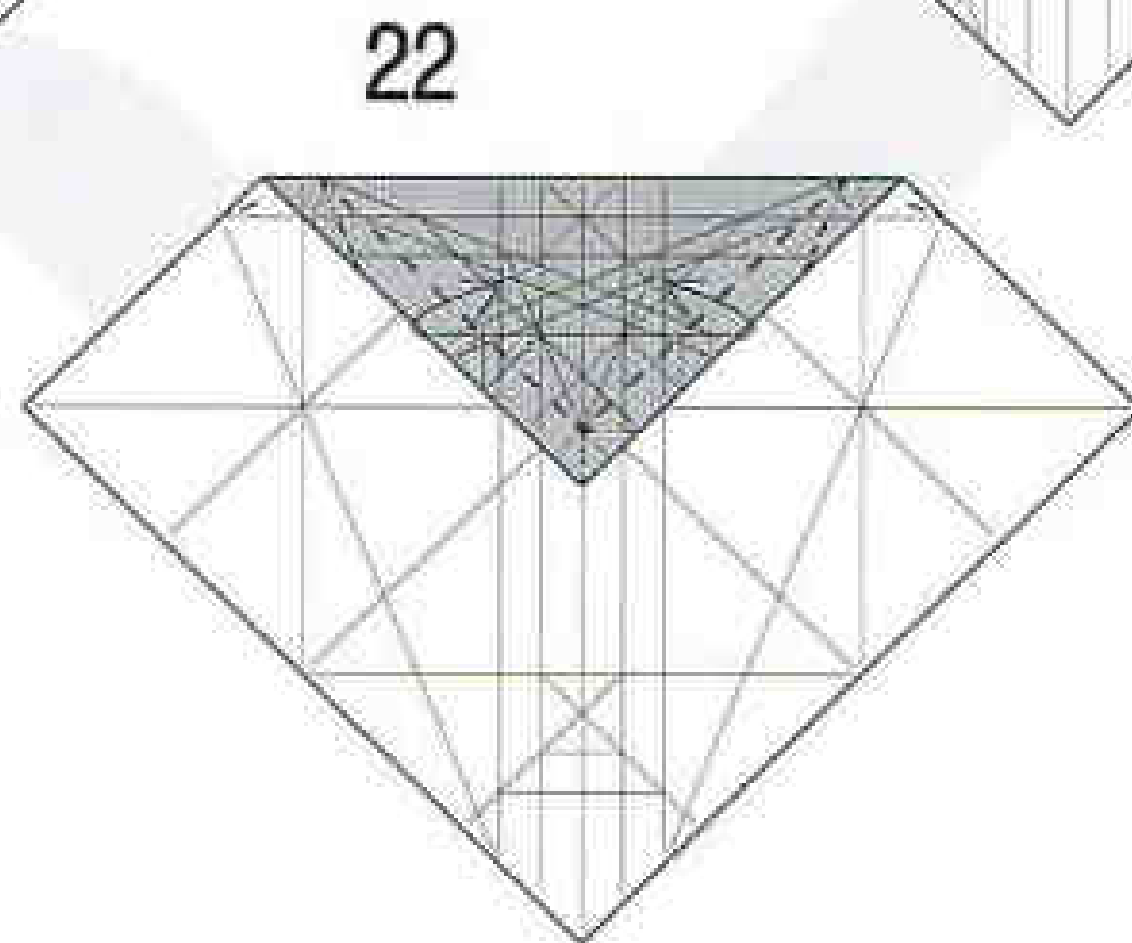
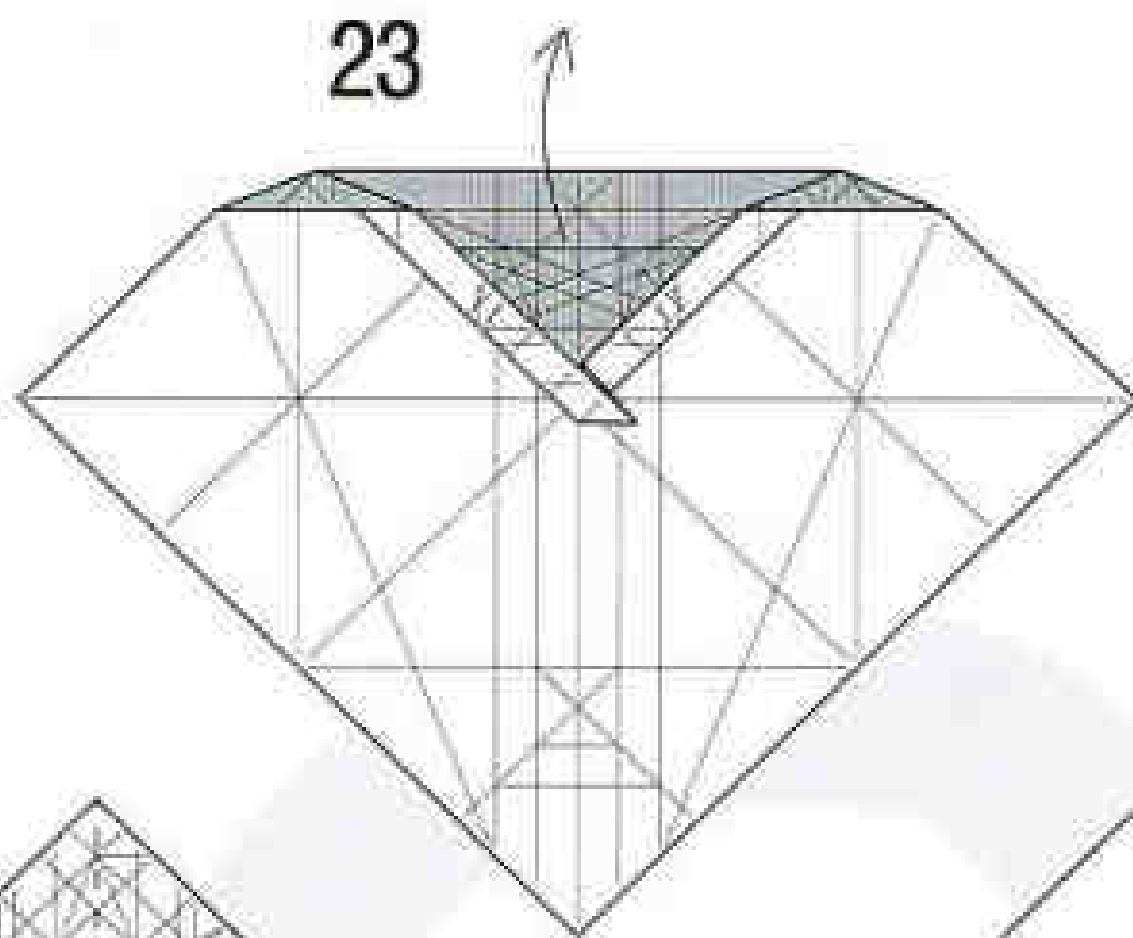
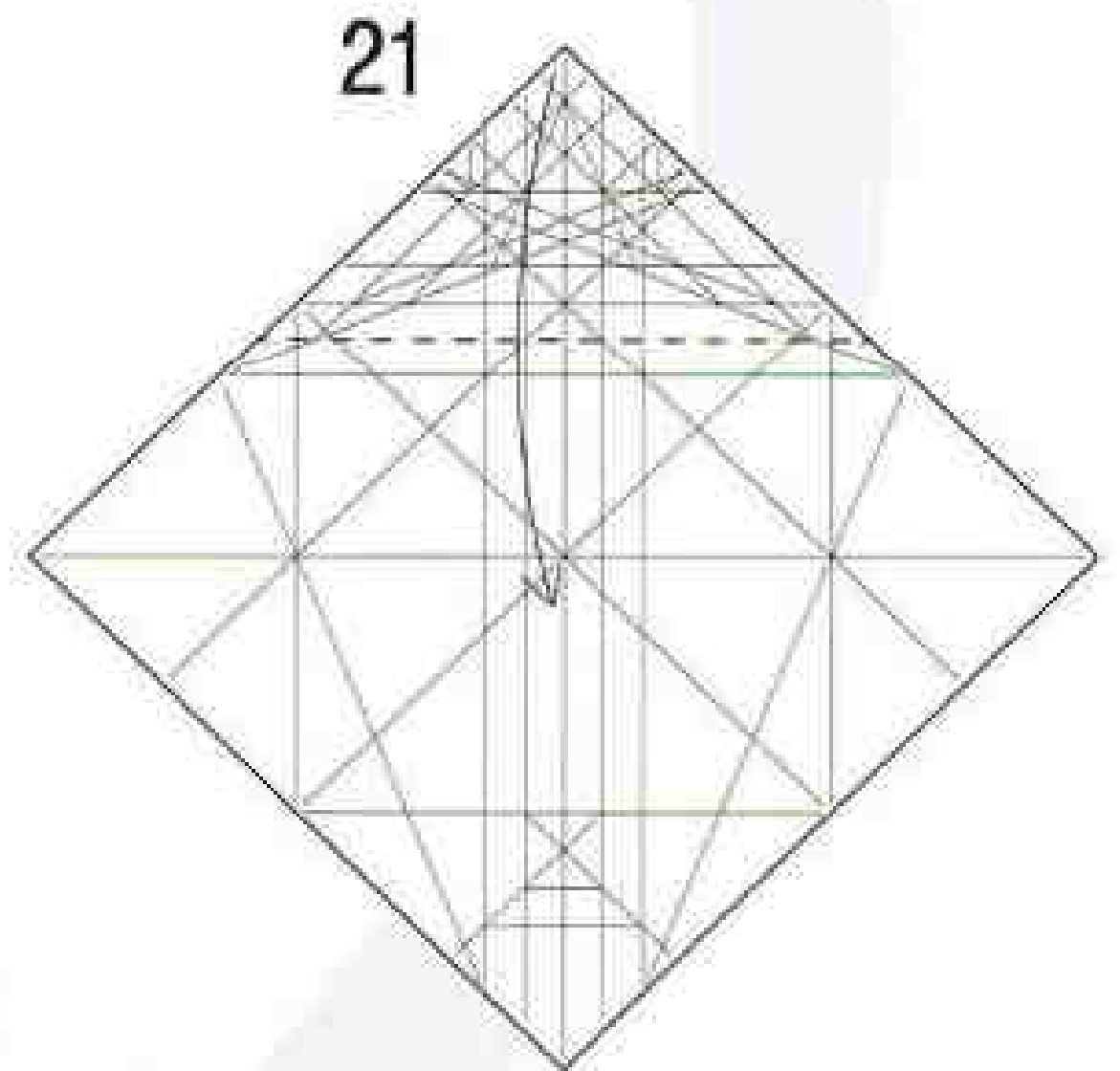
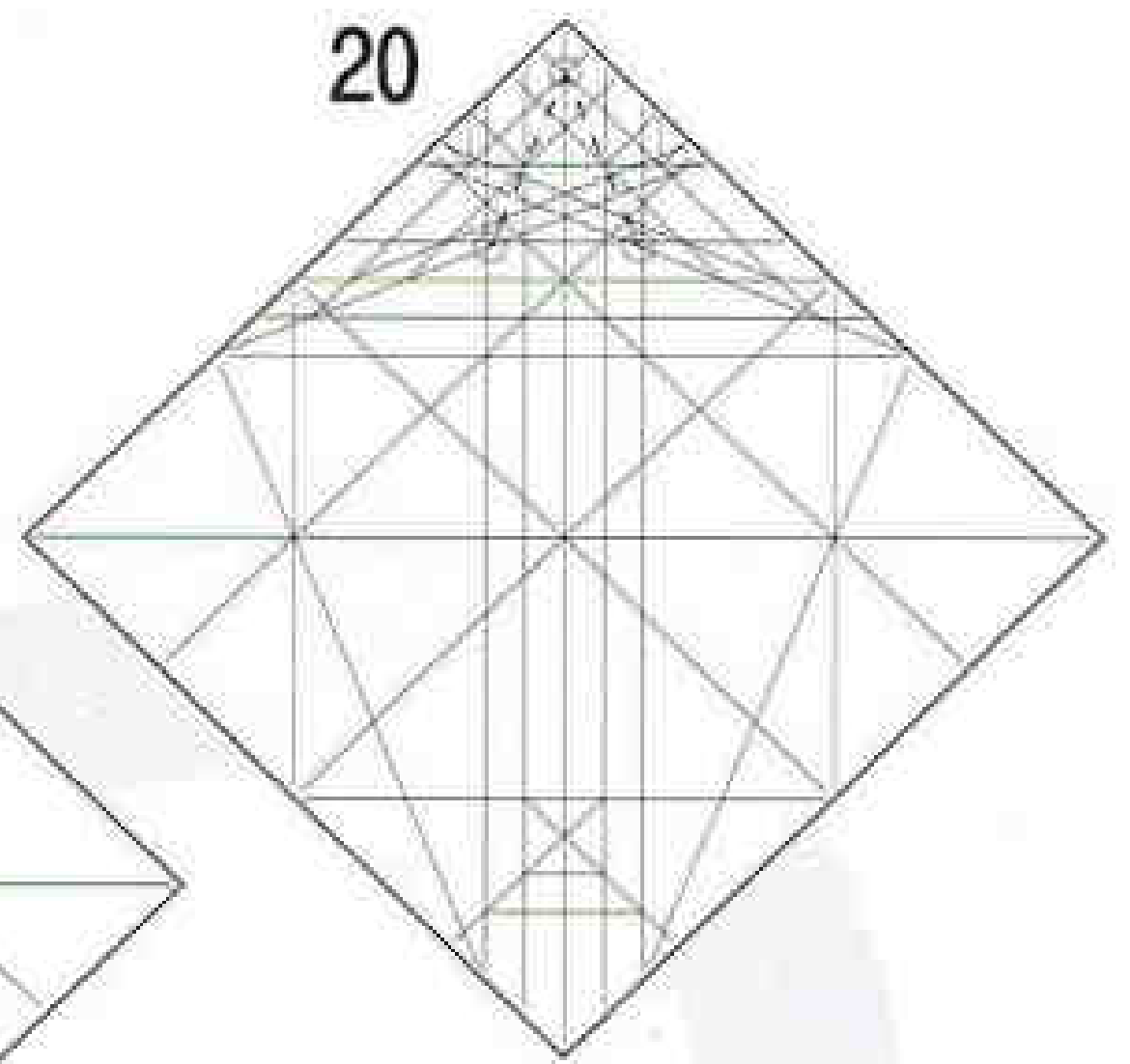
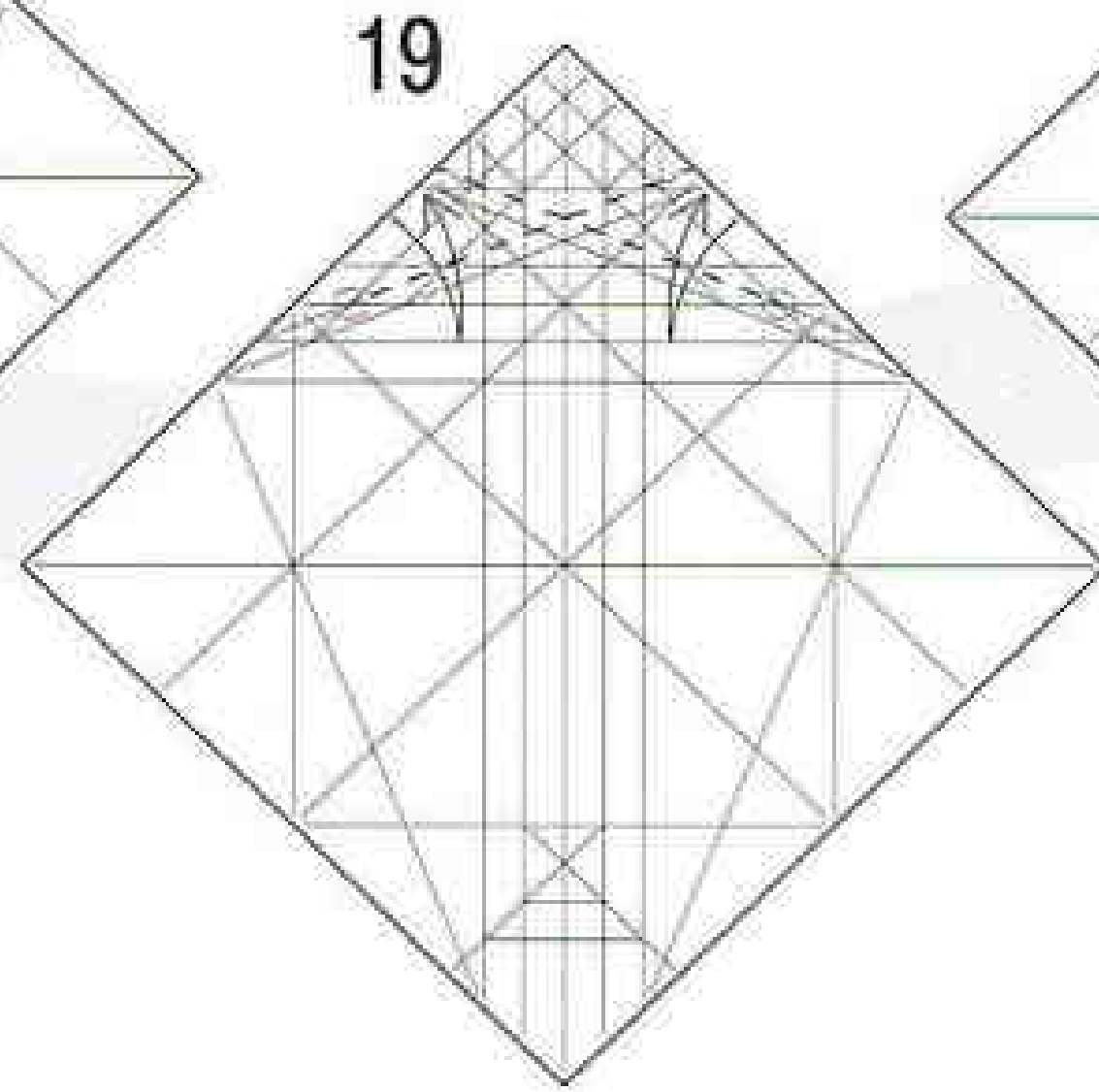
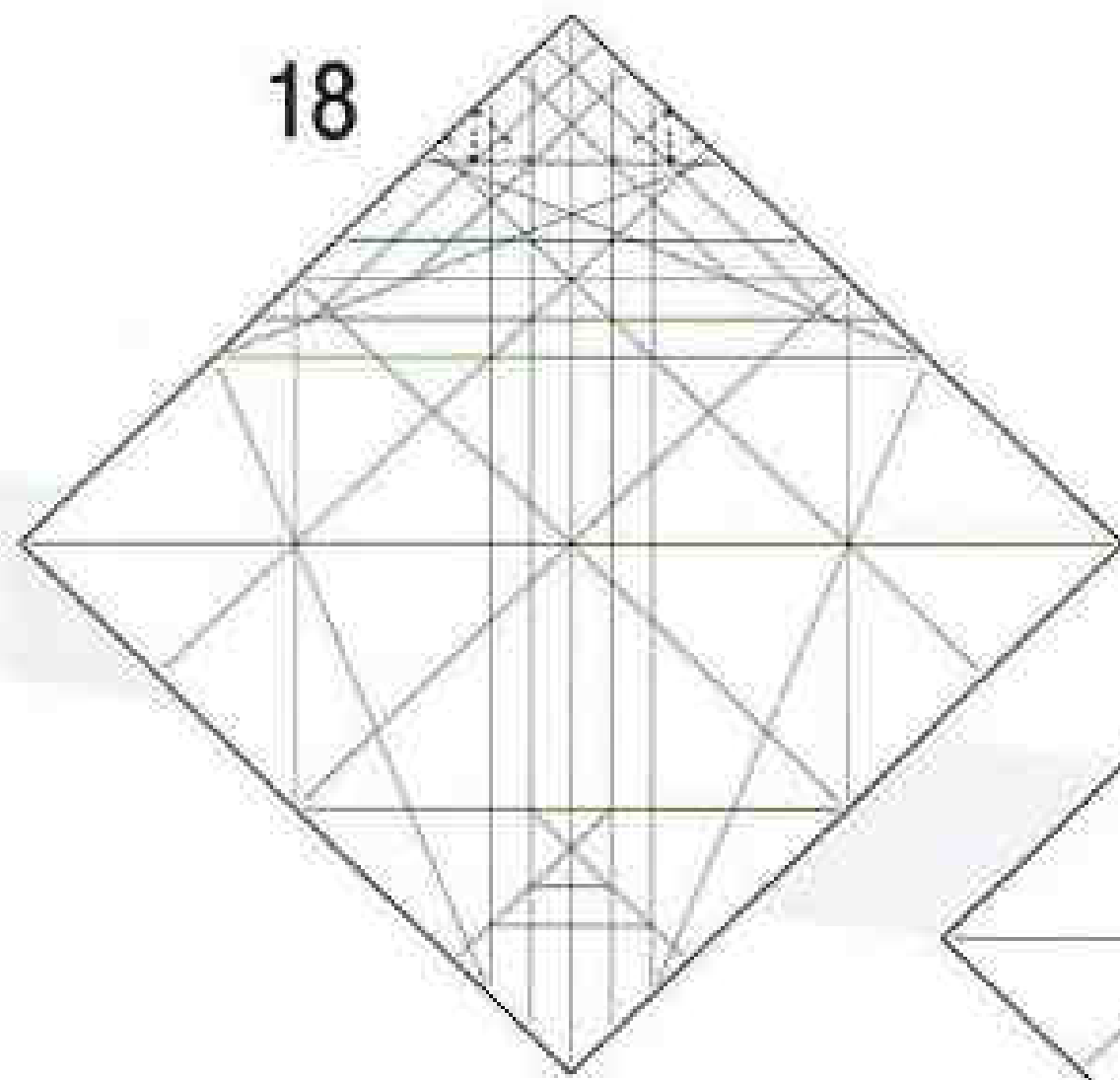

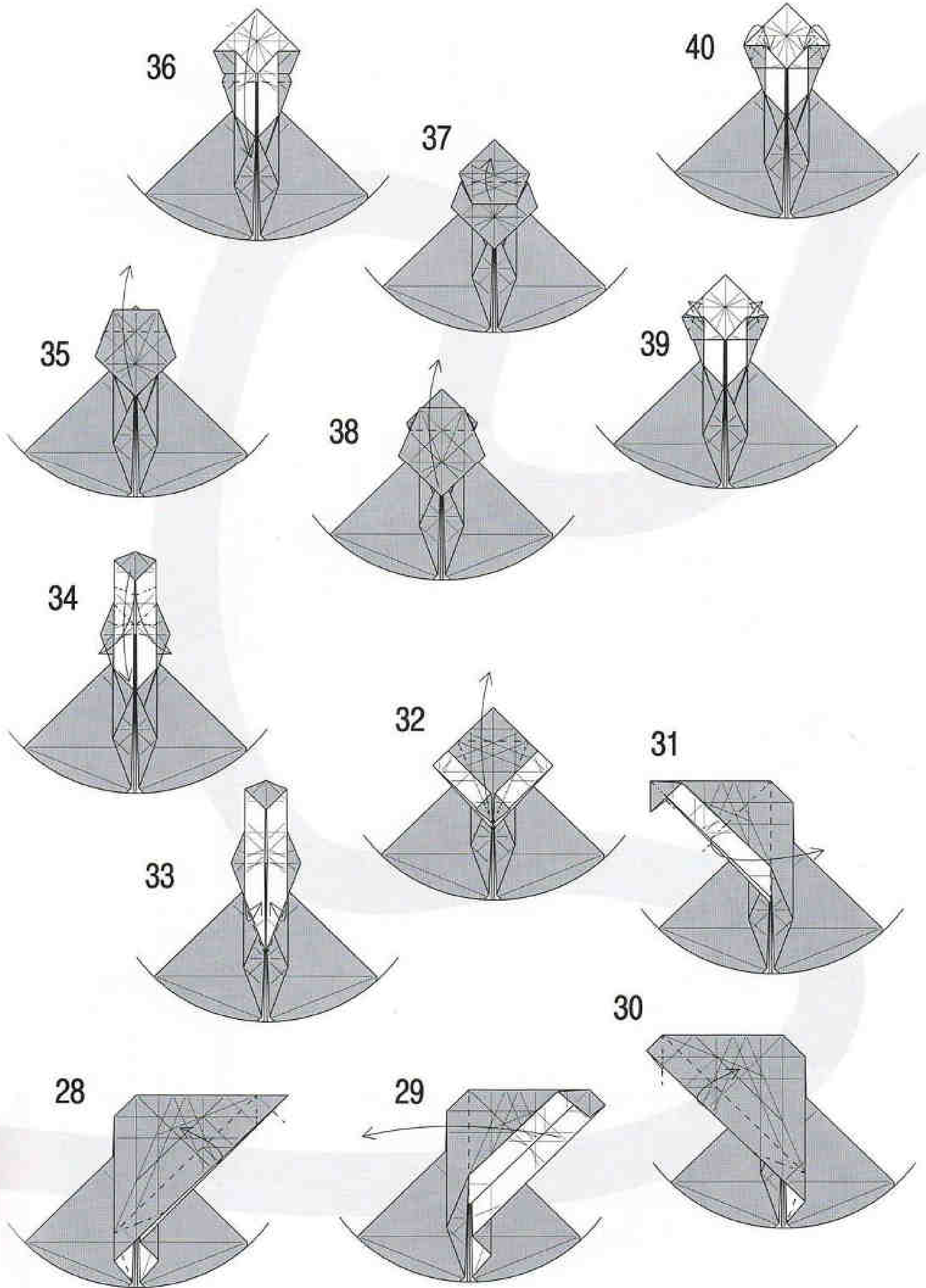

41

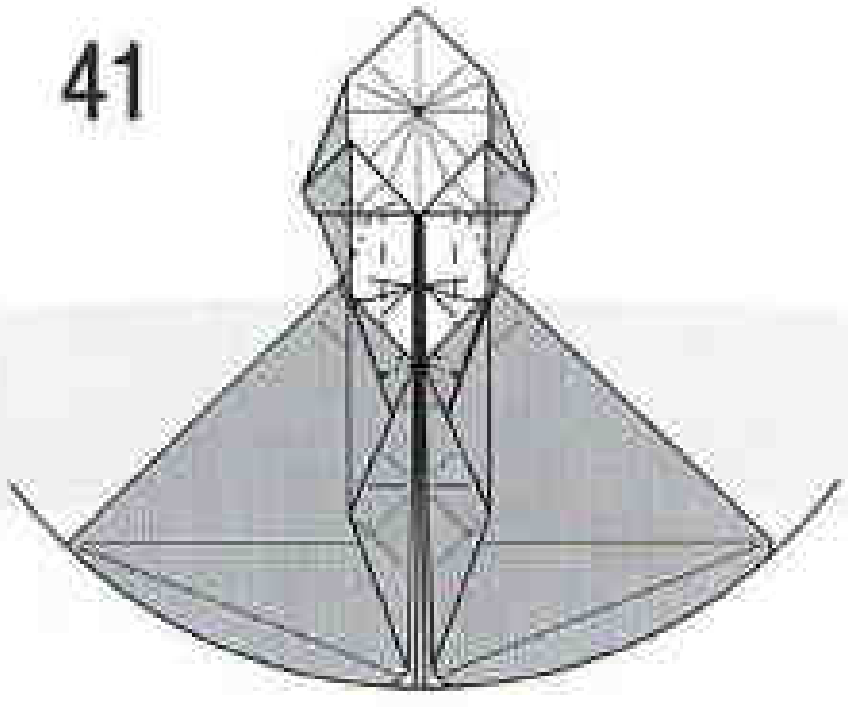

42

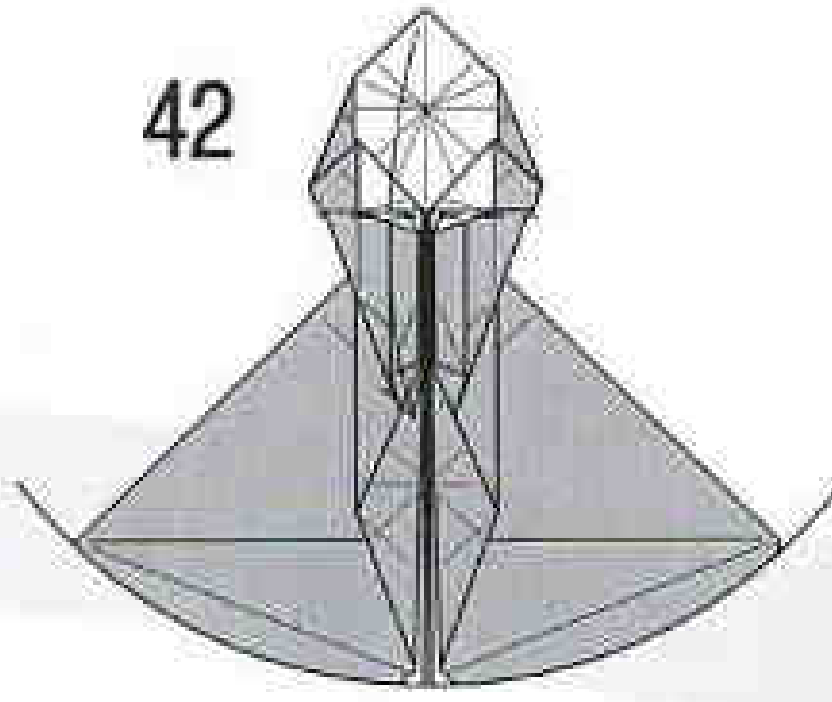

43

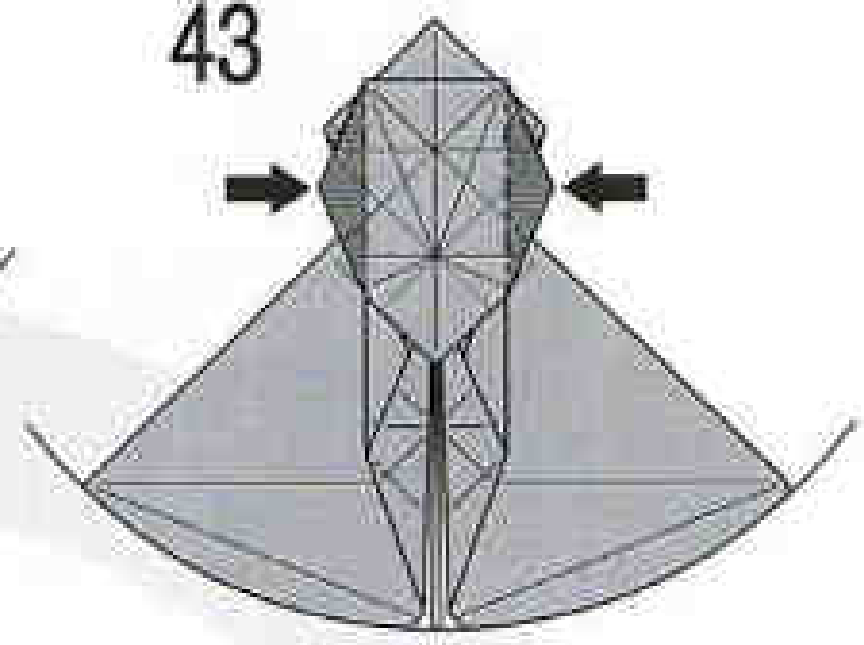

44

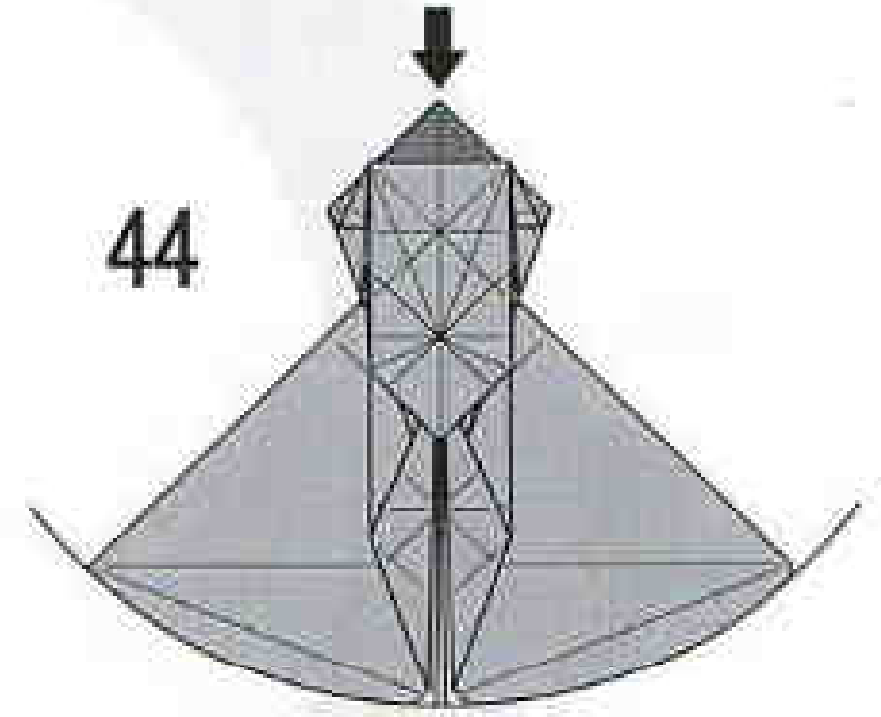

46

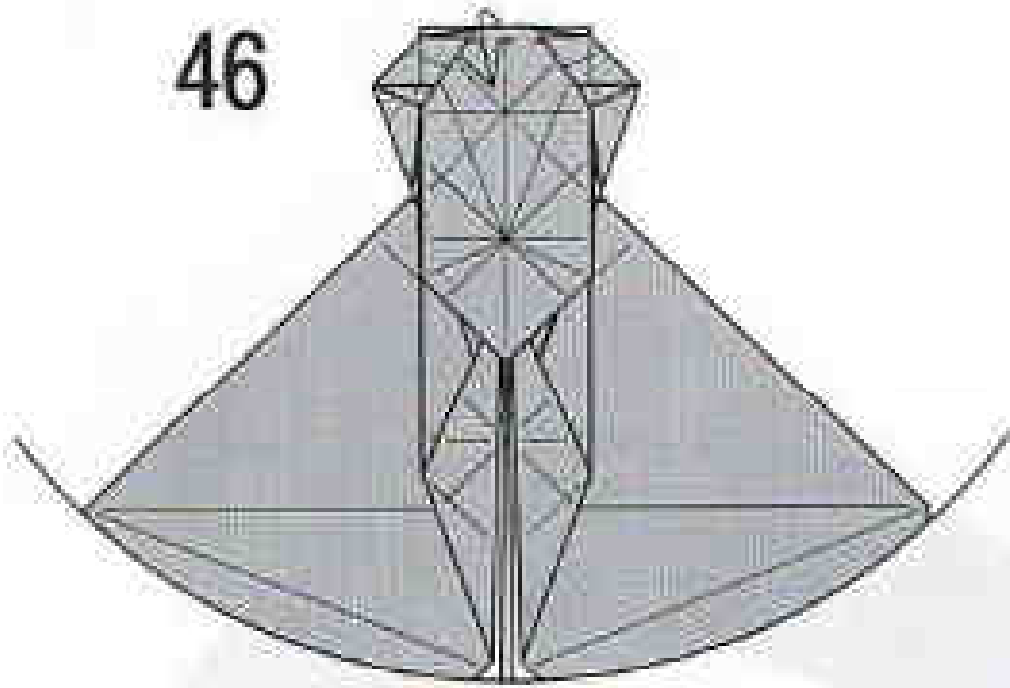

45

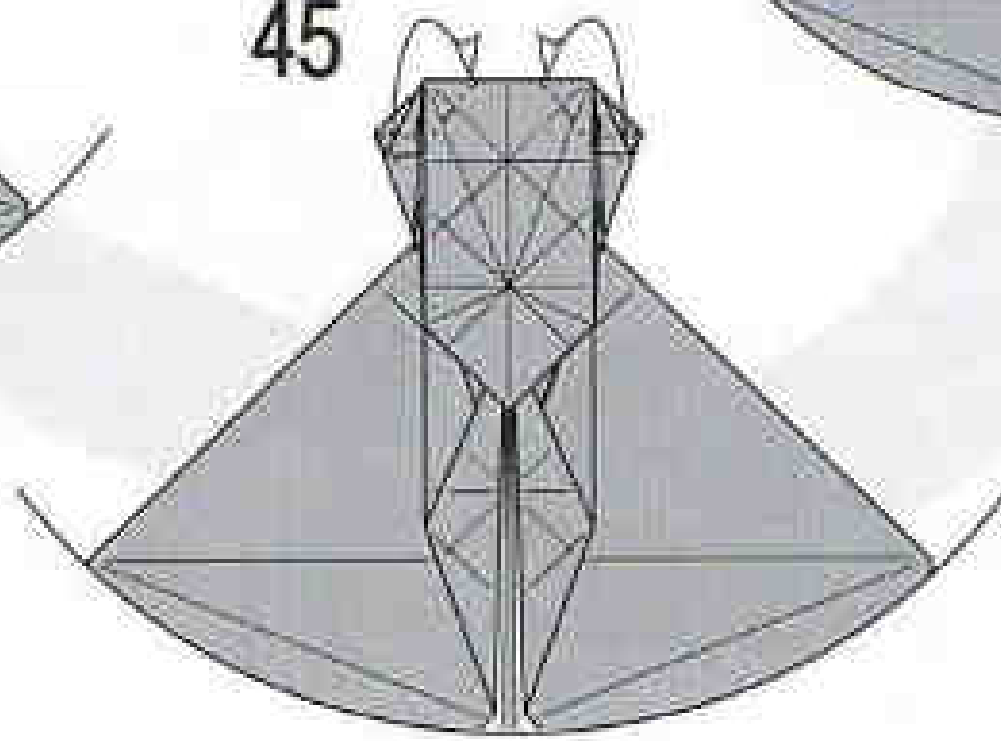

47

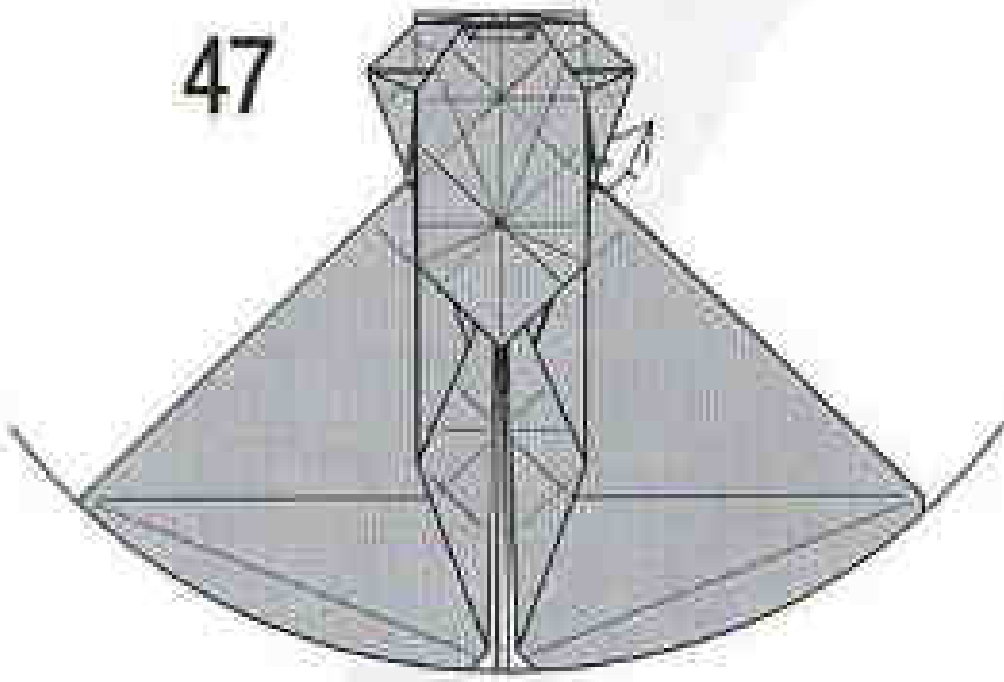

50

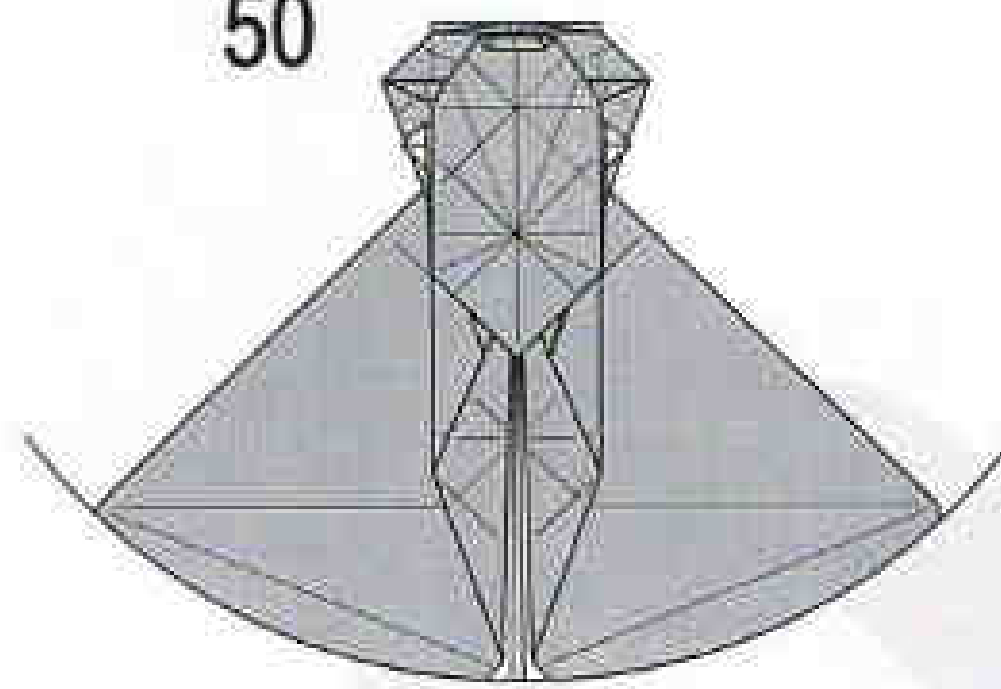

48

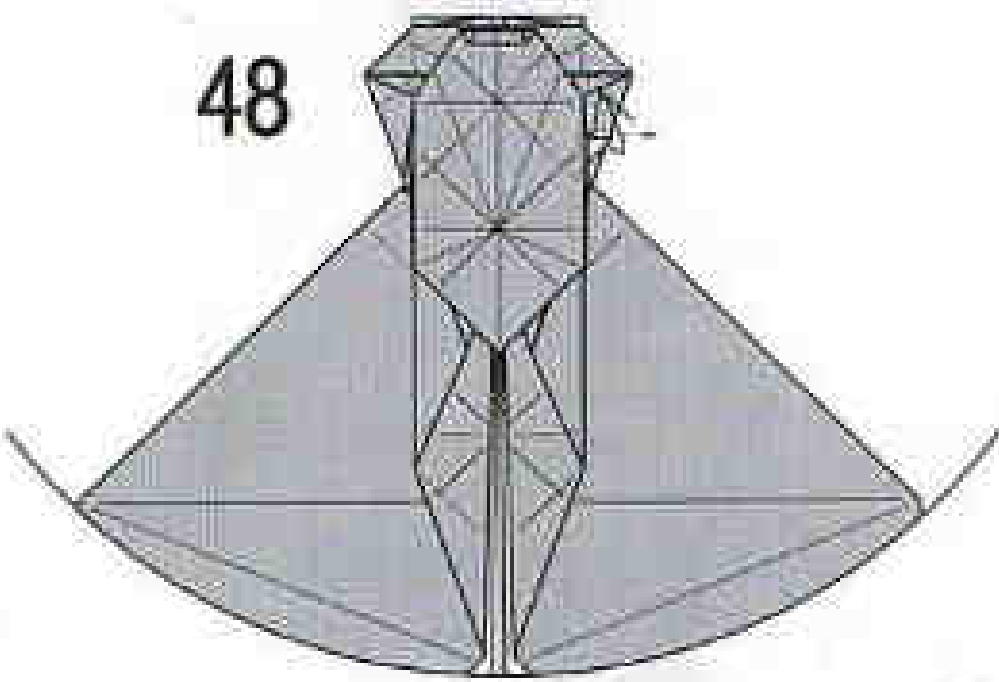

51

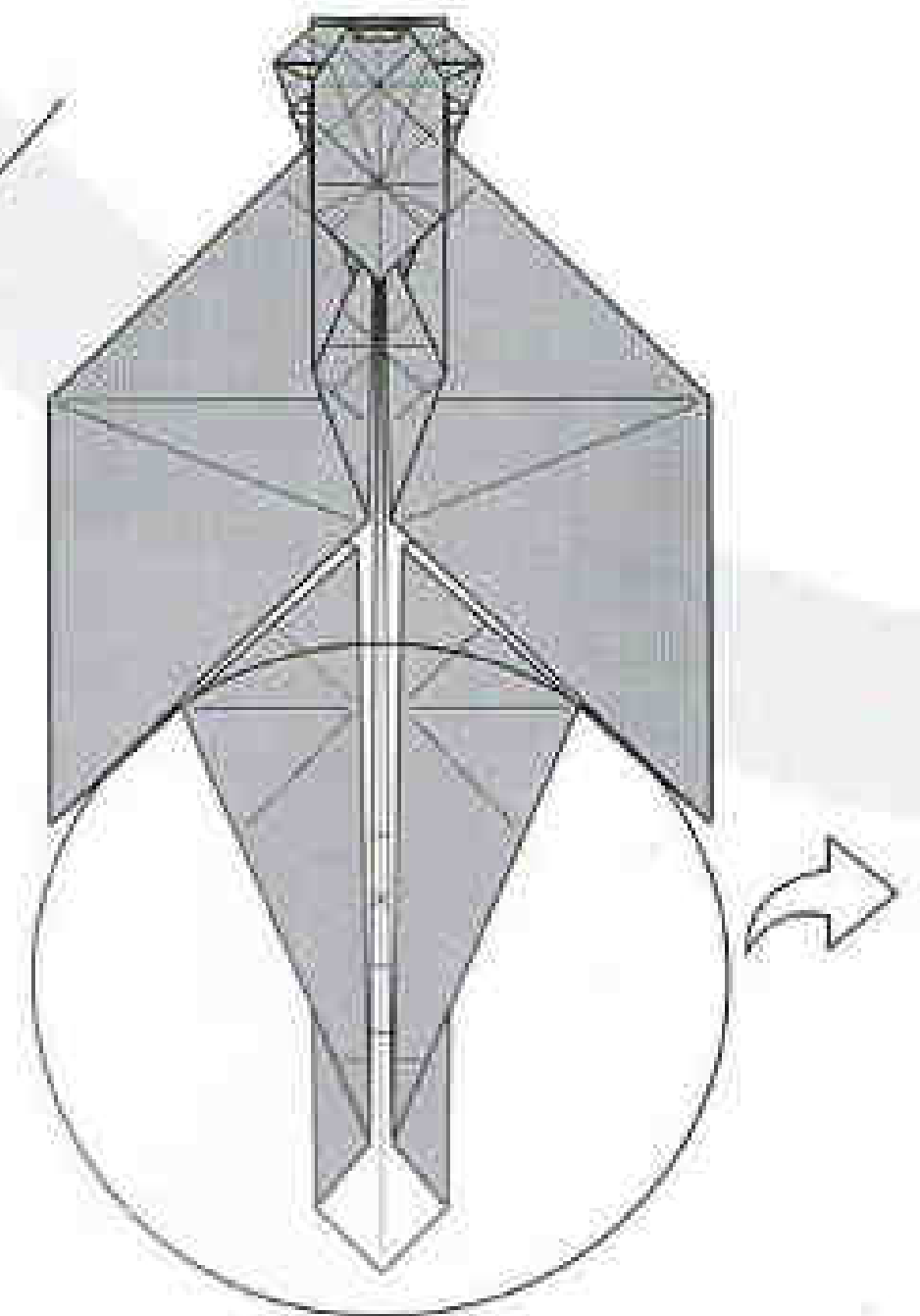

49

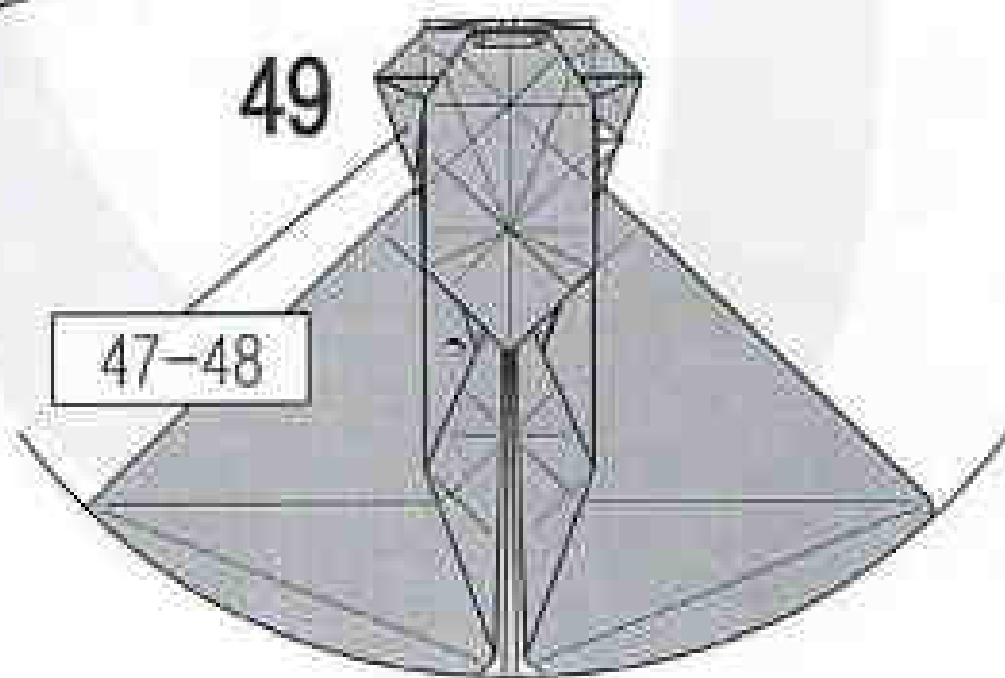

47-48

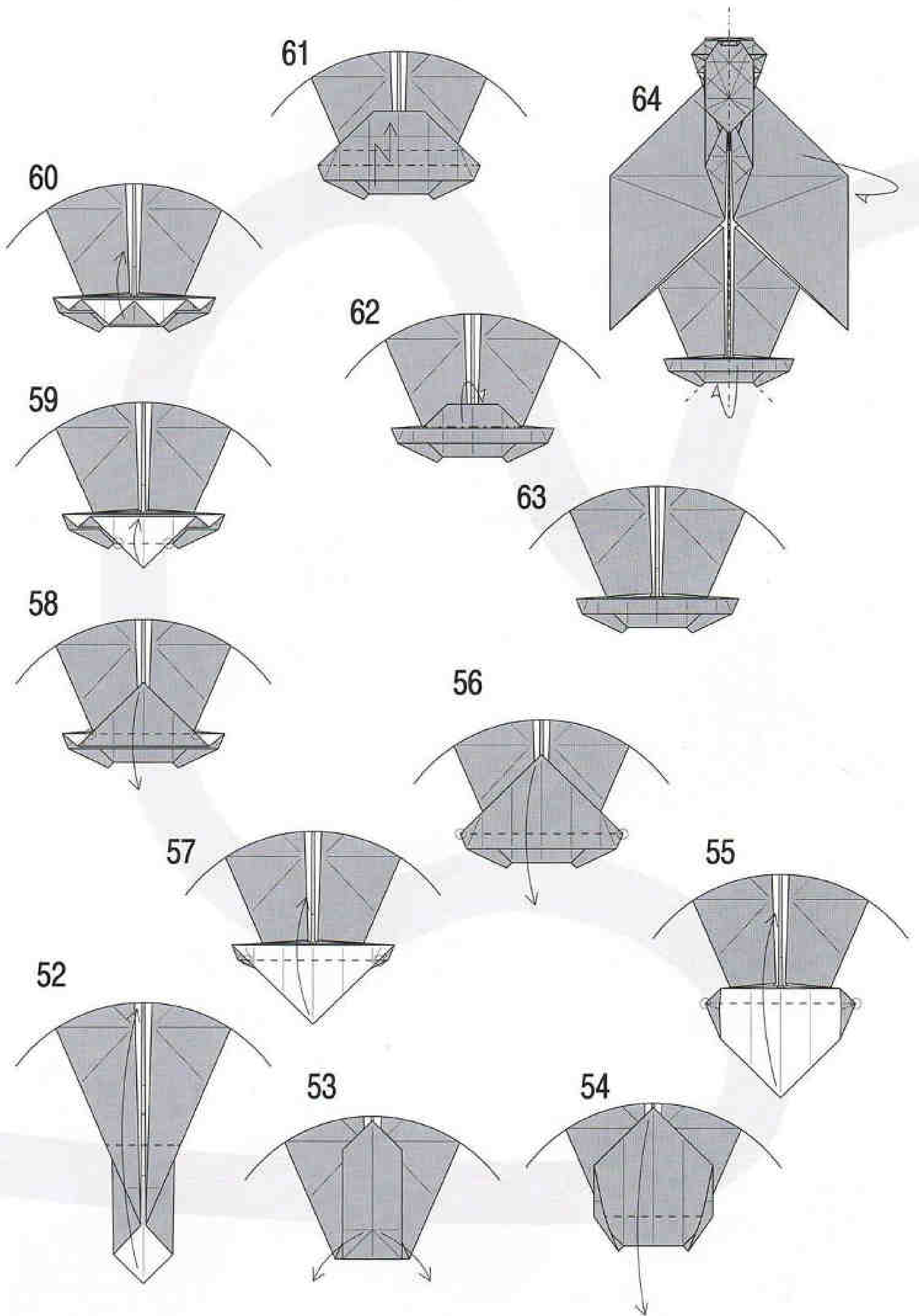

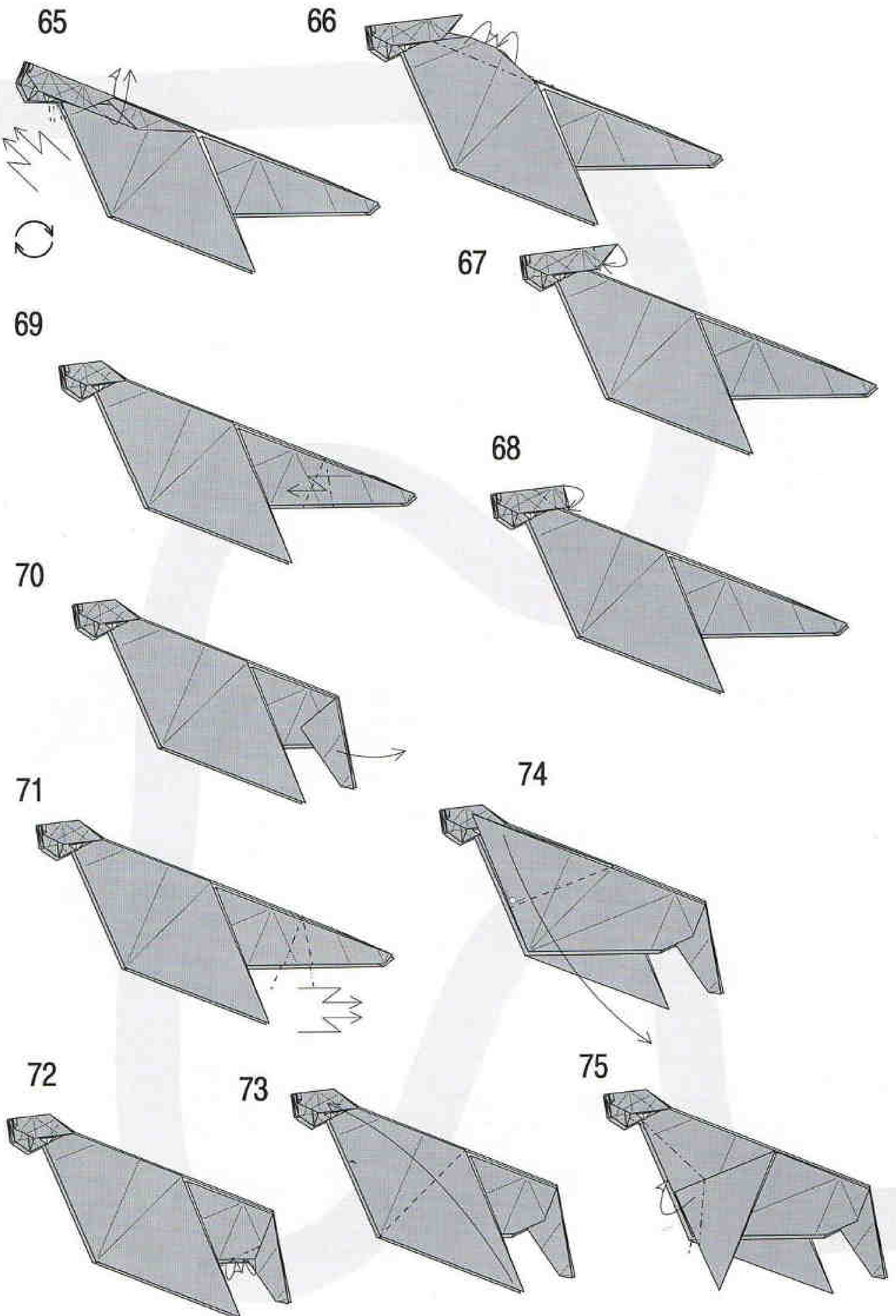

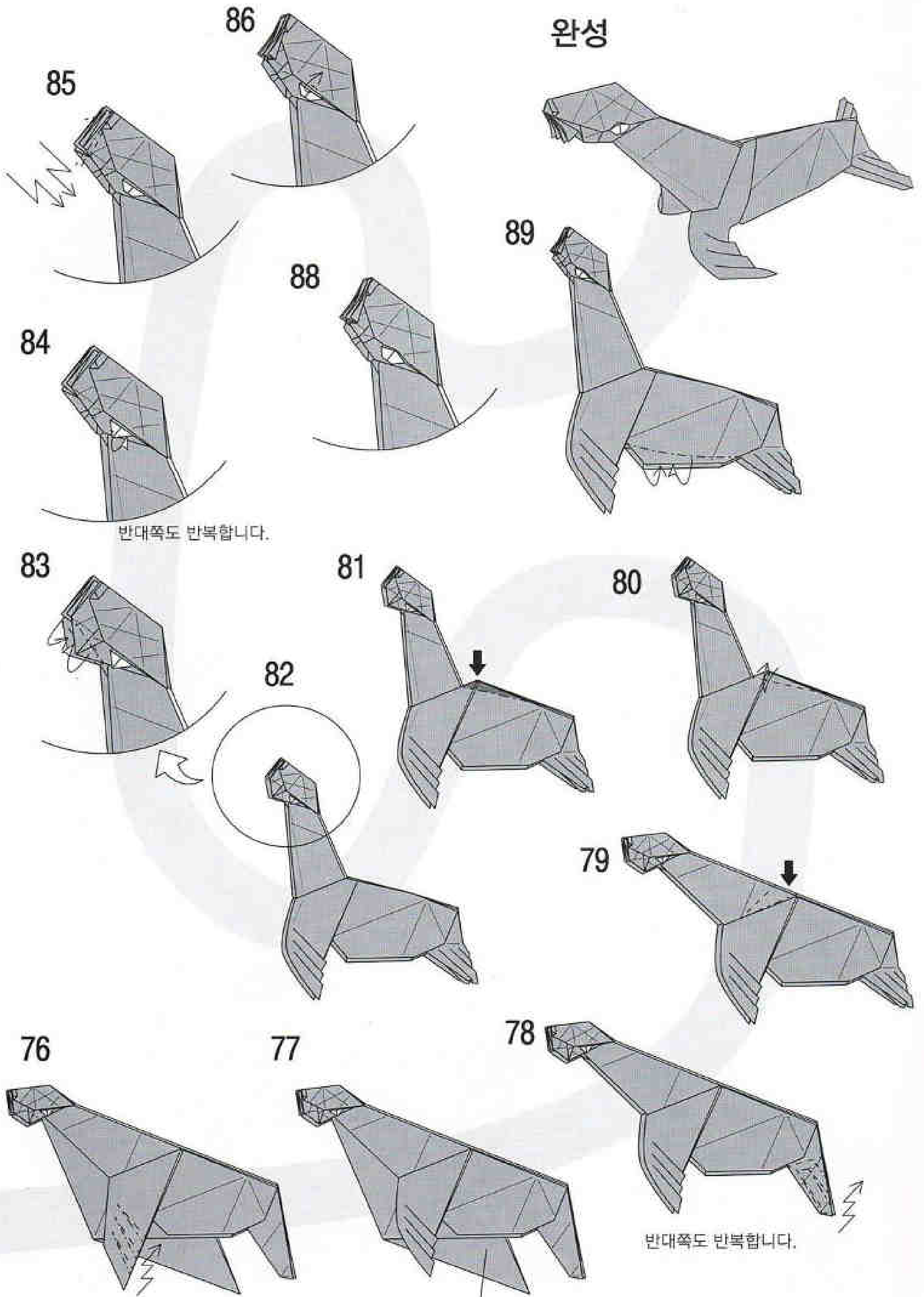

85

86

완성

84

88

89

반대쪽도 반복합니다.

83

81

80

82

79

76

77

78

반대쪽도 반복합니다.

73-76

멧돼지 (Wild Boar)

창작가 : 장용익 (Jang Yong Ik)

다이어그램 : 장용익 (Jang Yong Ik)

창작일 : 2015.06.29

종이크기 : 55cm x 55cm

멧돼지의 갈기 표현을 목표로 창작하였습니다. 동물작품은 무엇보다 머리 부분의 조형이 중요하다고 생각하고 있기 때문에 다른 작가들과 차별을 주기 위해 많은 노력을 기울여 그 결과 저만의 디자인이 담긴 멧돼지를 만들 수 있었습니다. 심플하게 빠지는 다리가 빈약하다는 의견이 있었지만 마음에 들어서 다리의 디테일한 표현은 다음에 도전해 보려 합니다.

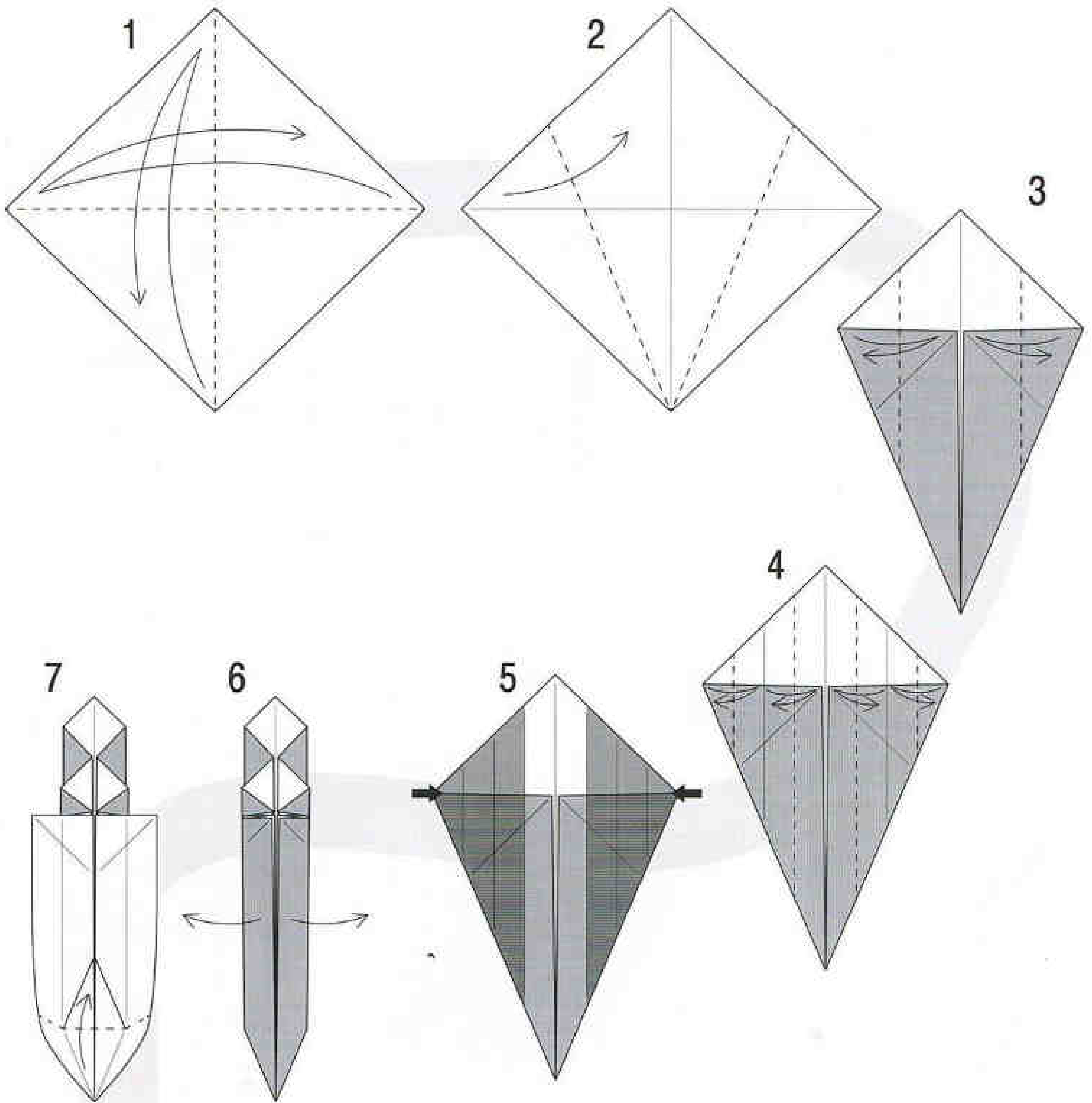
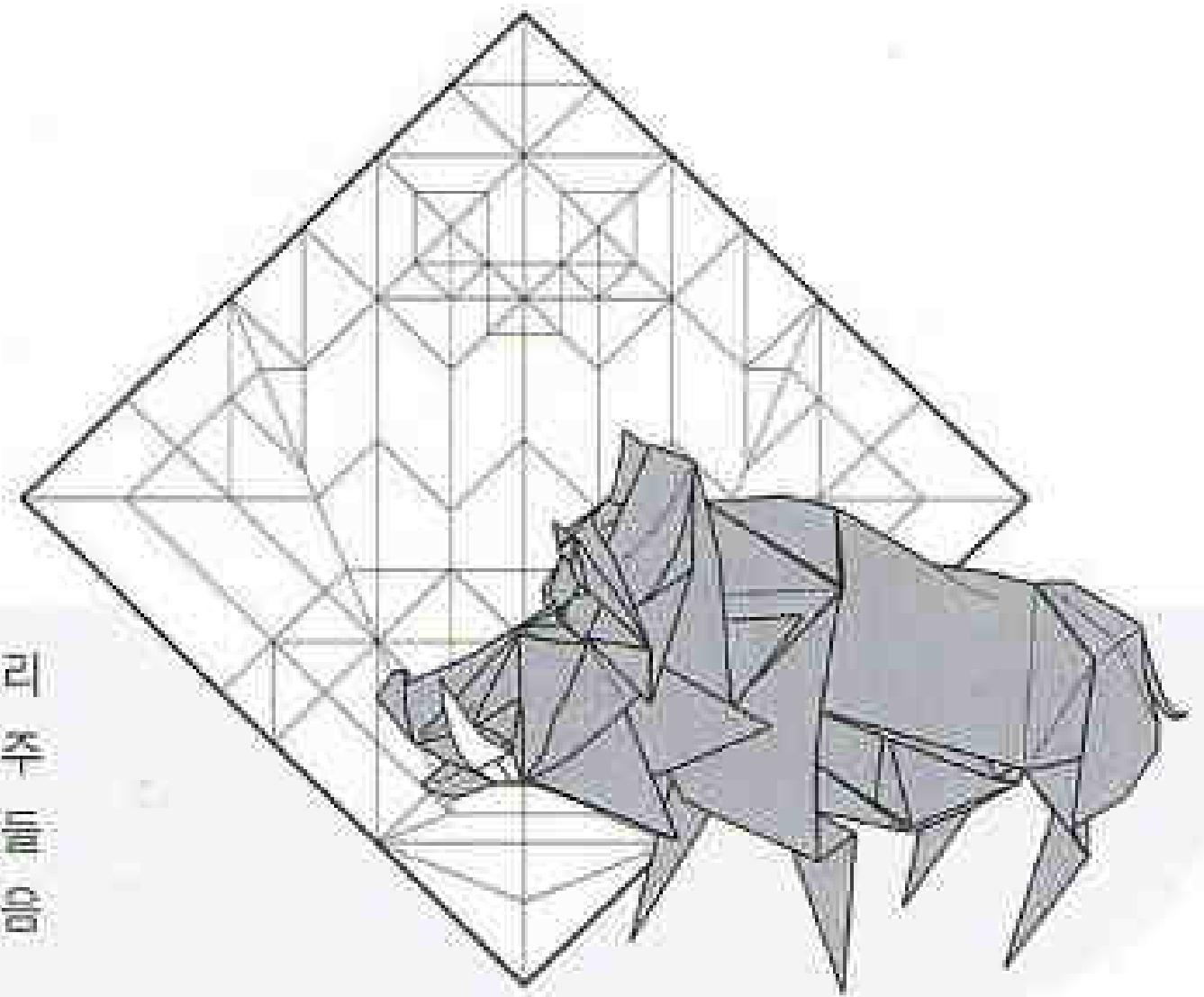

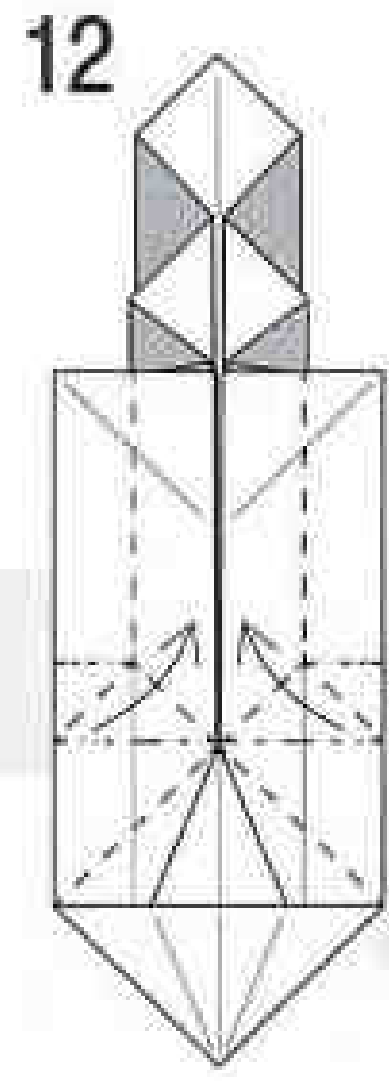
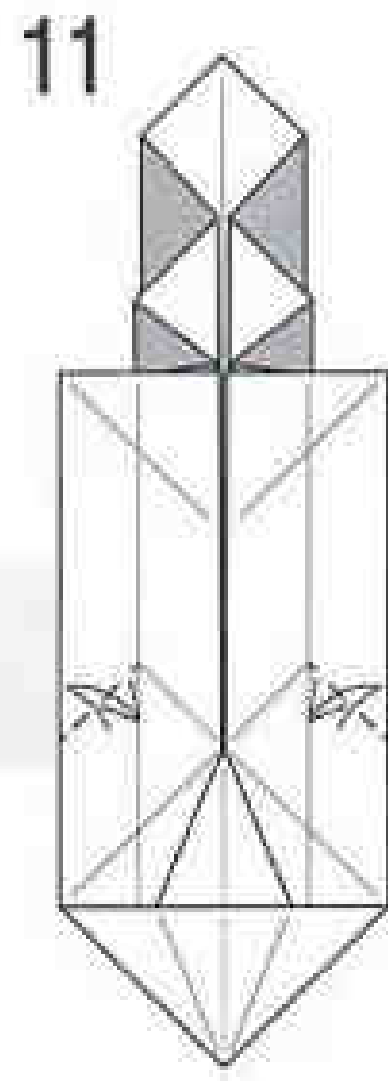
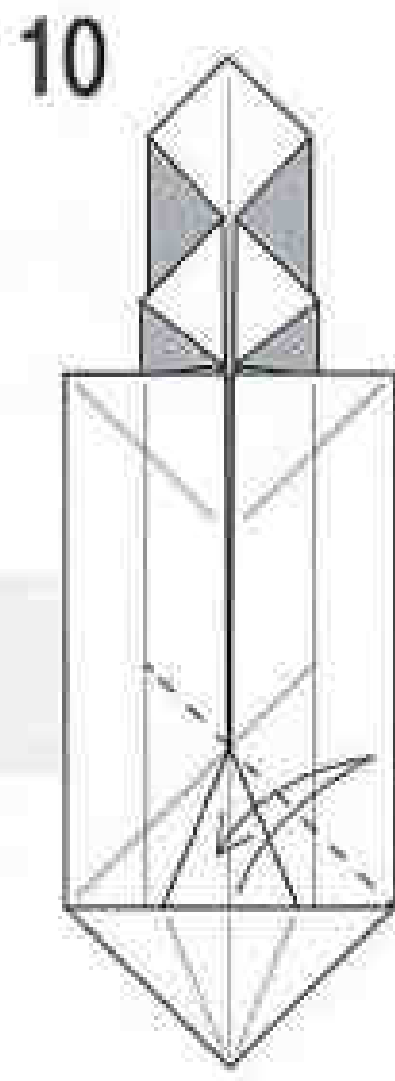
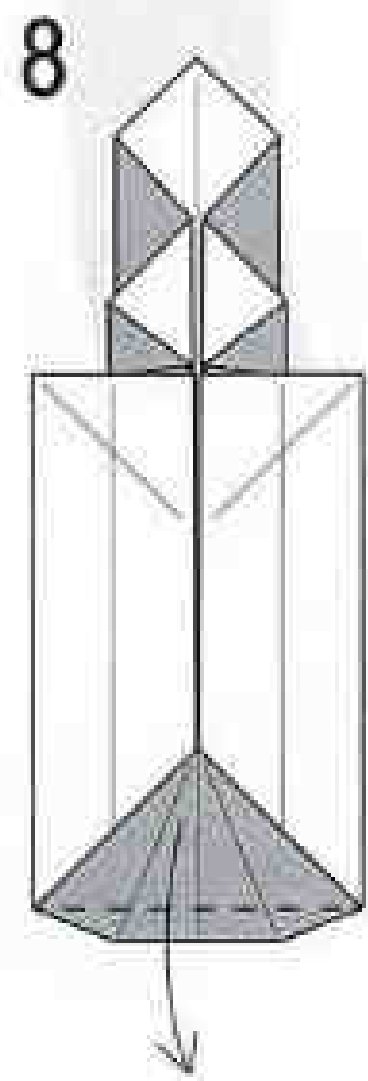

13

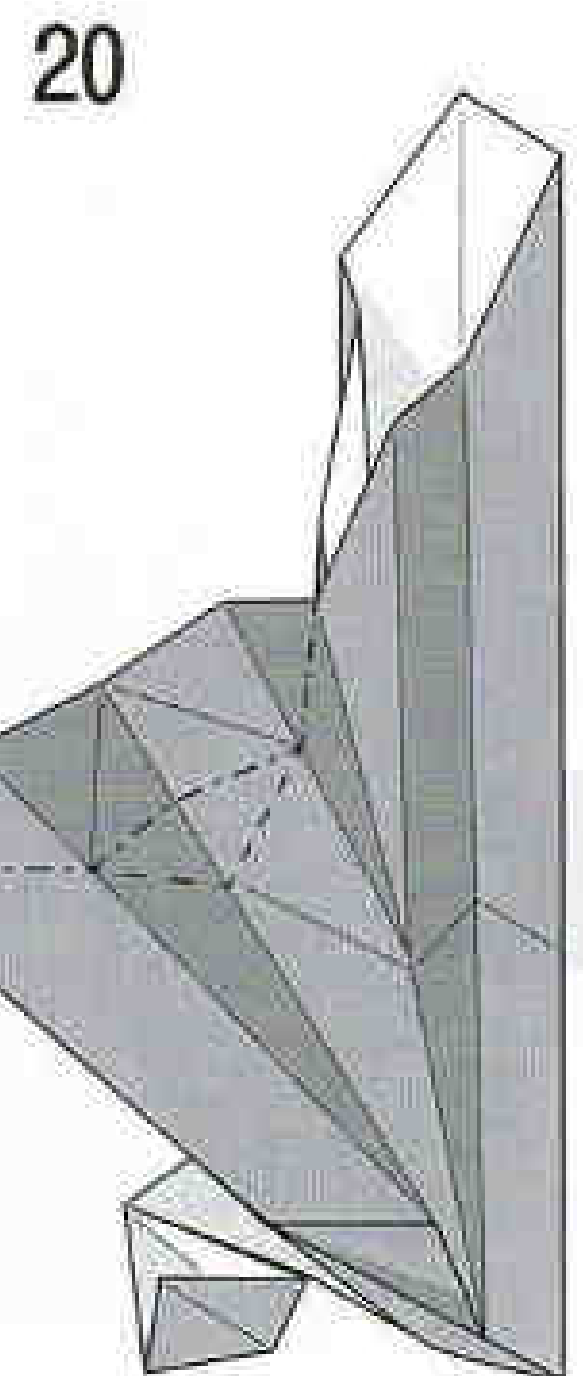
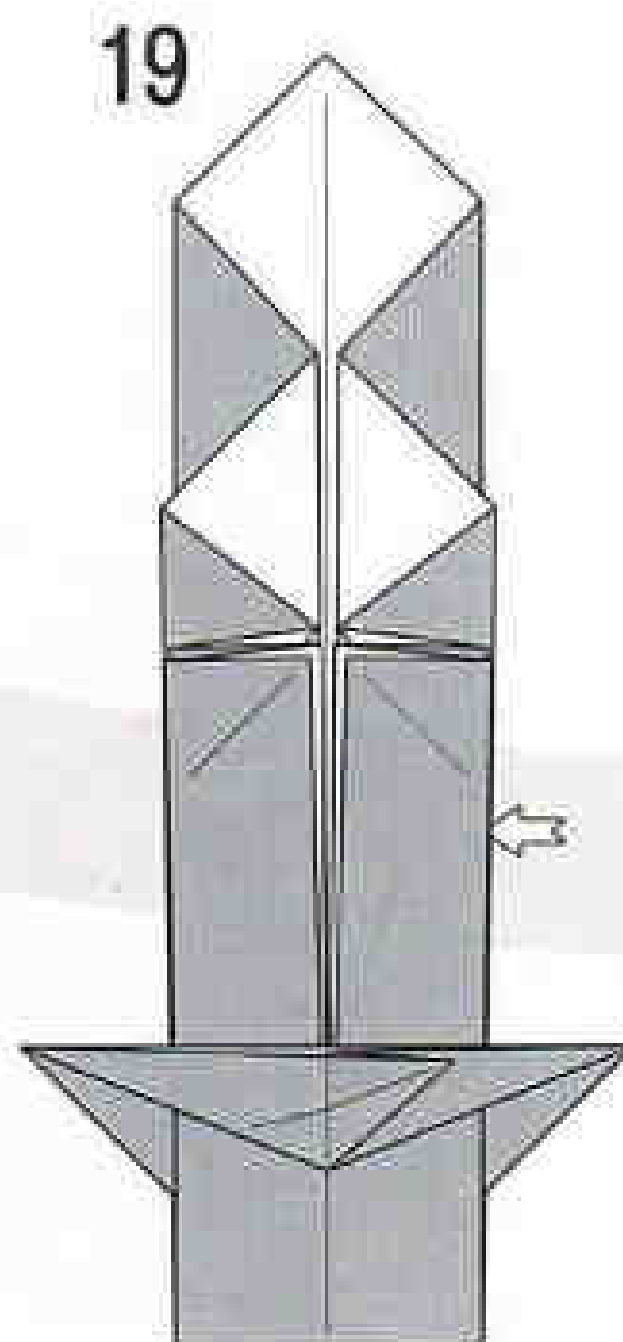
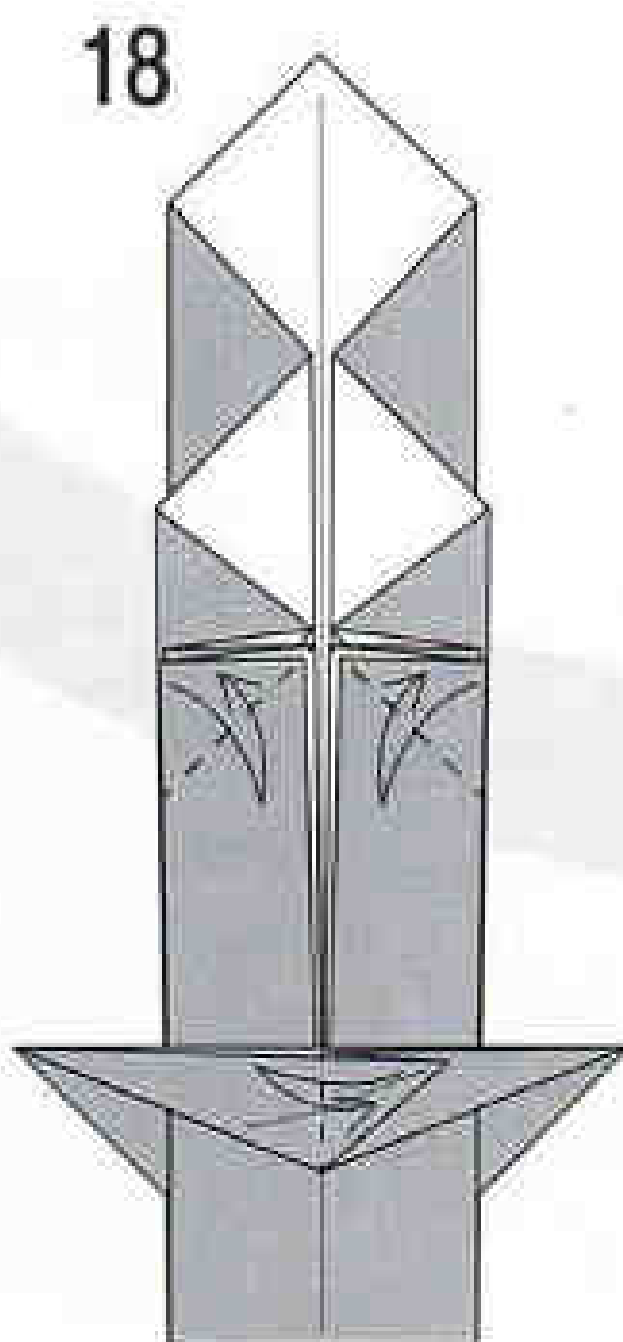
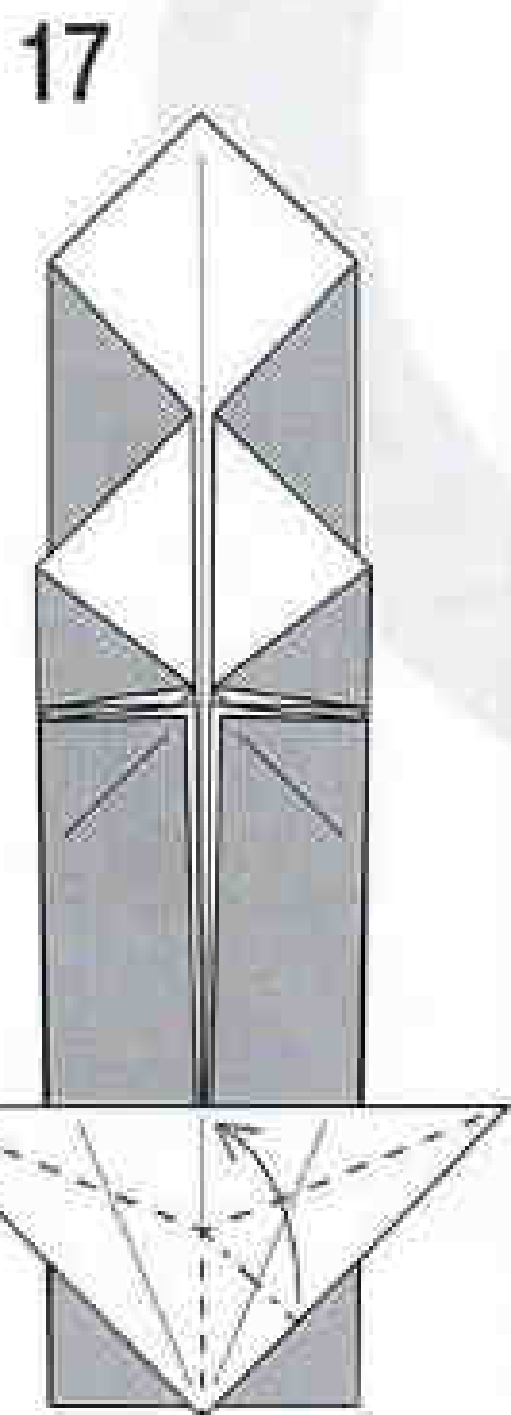
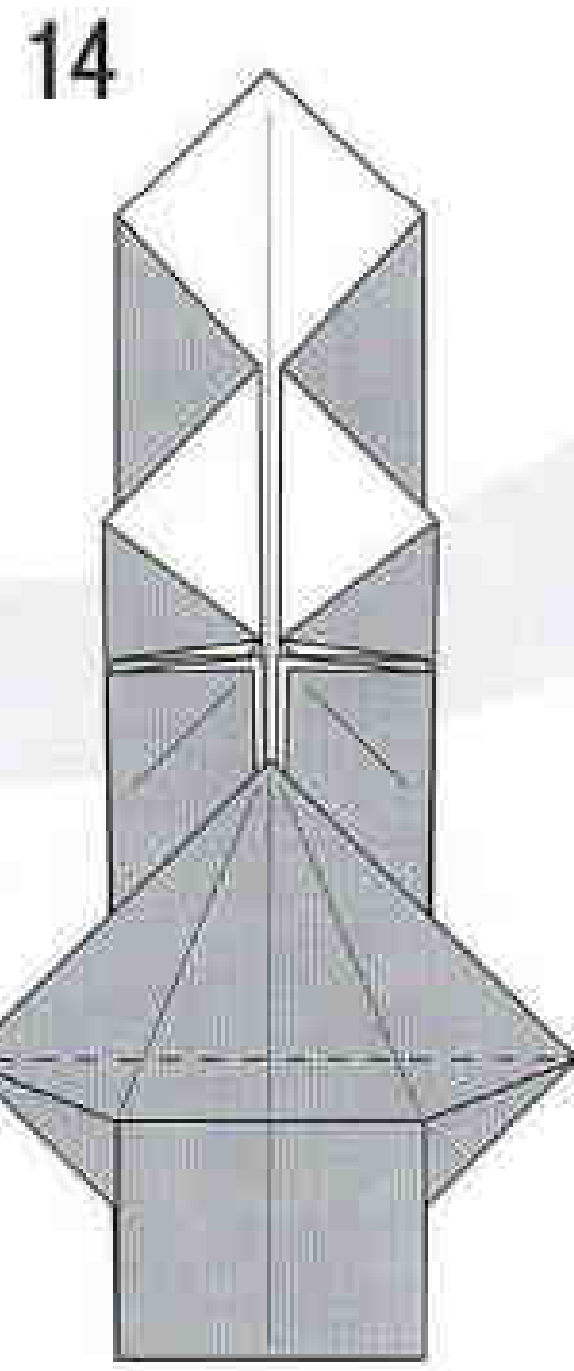
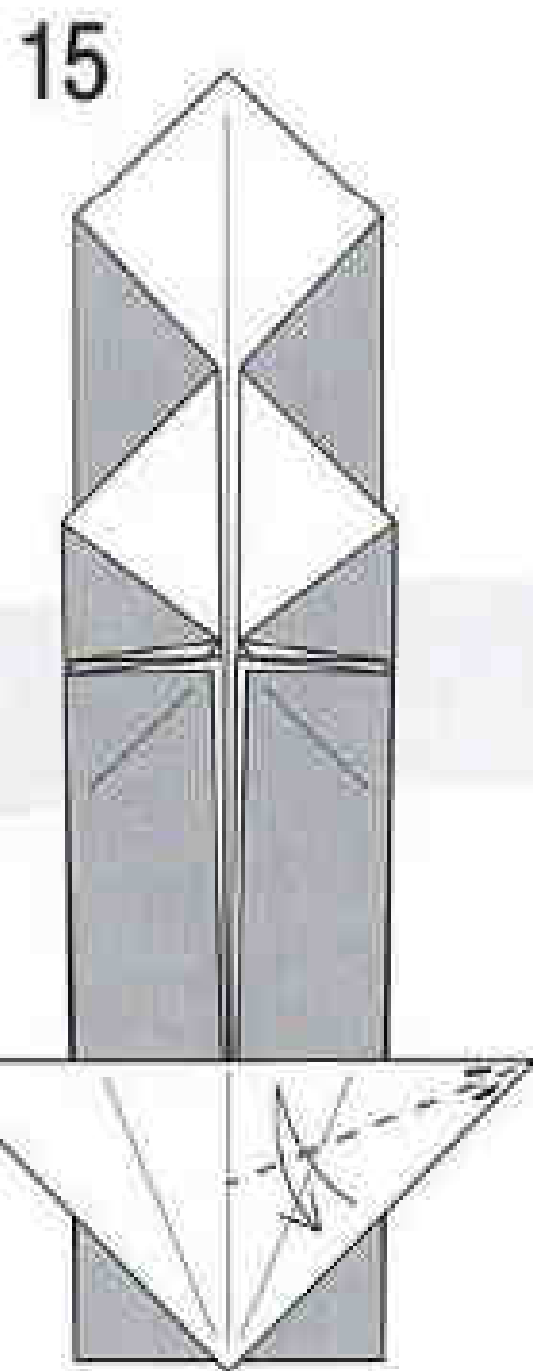
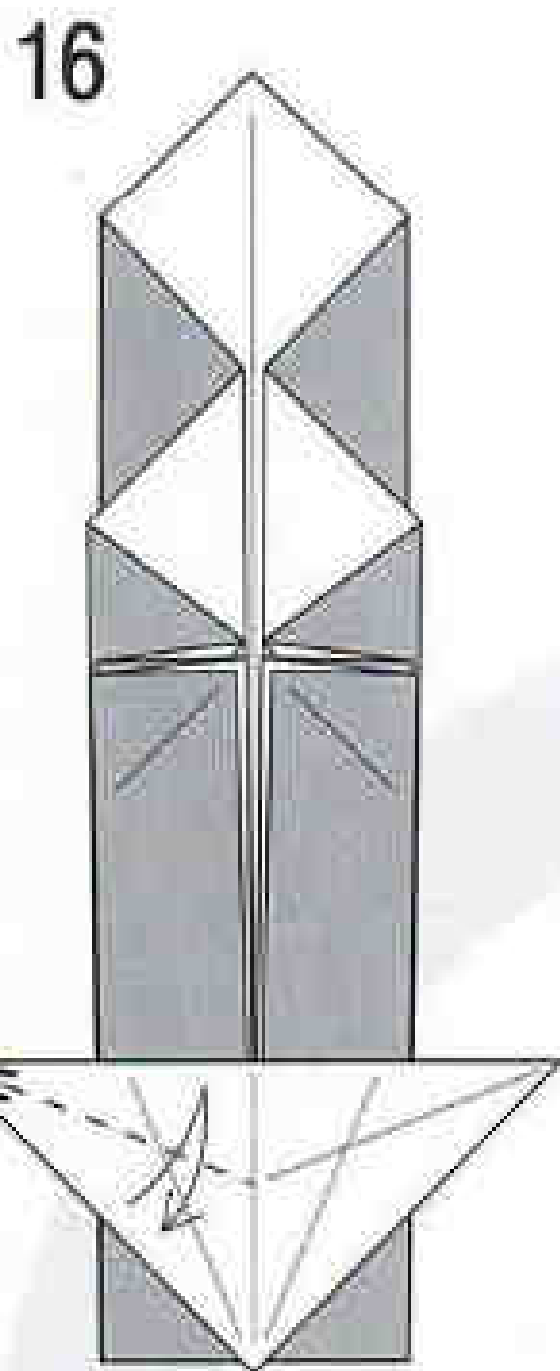
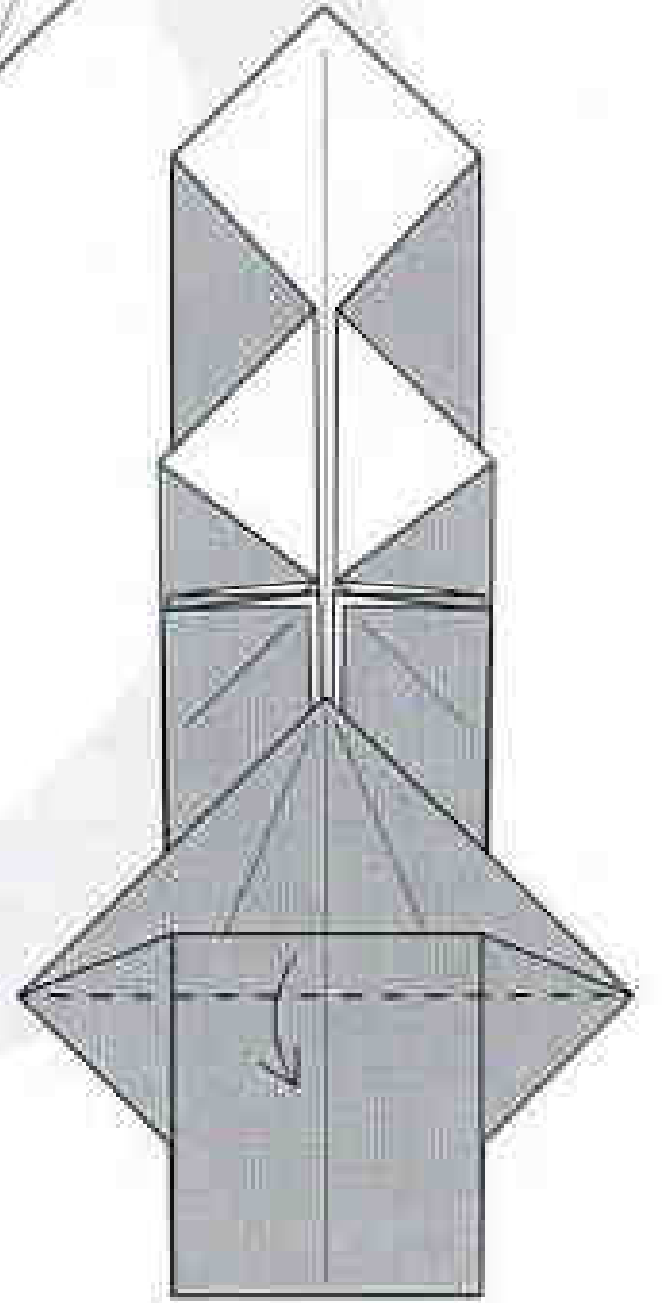

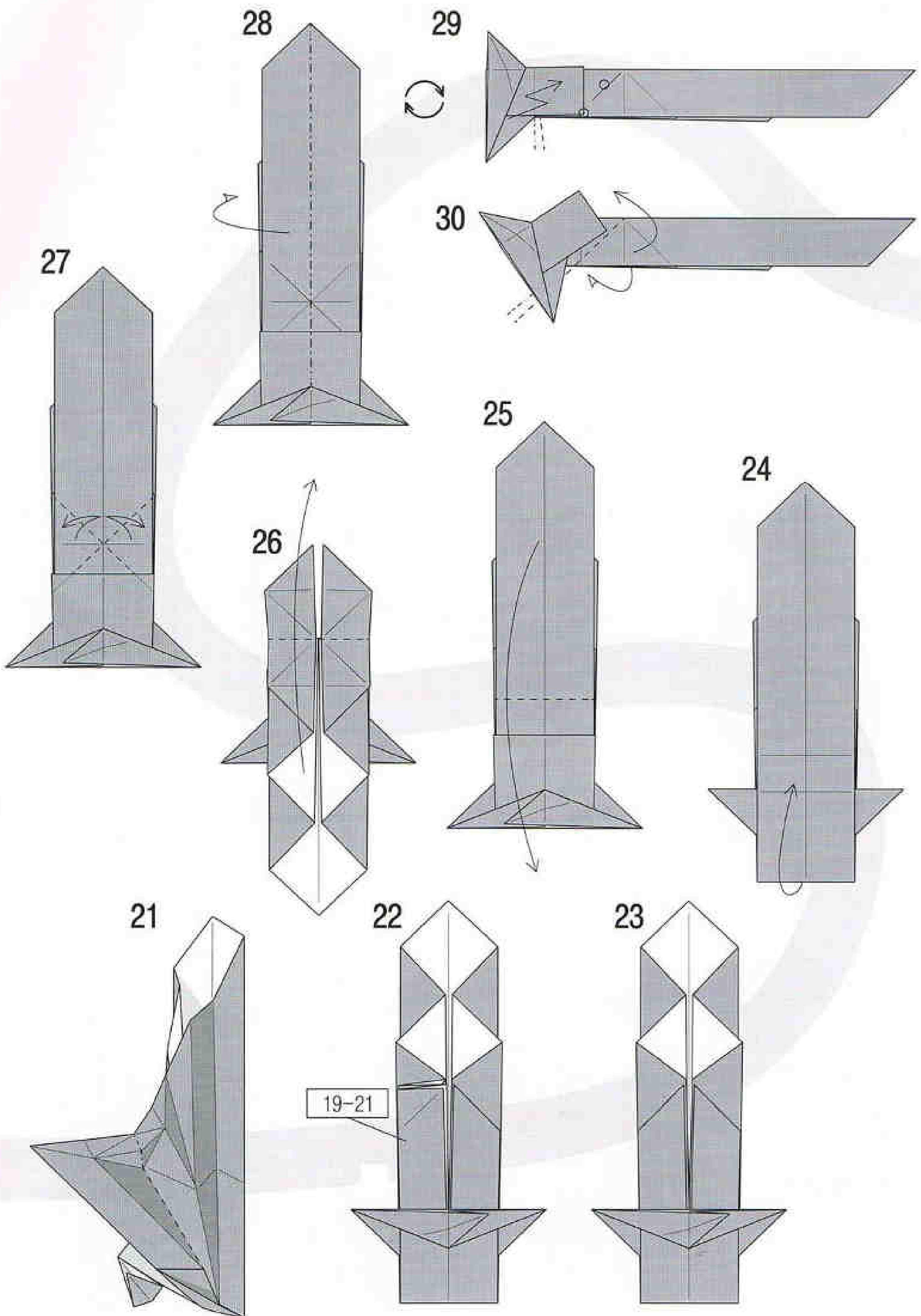

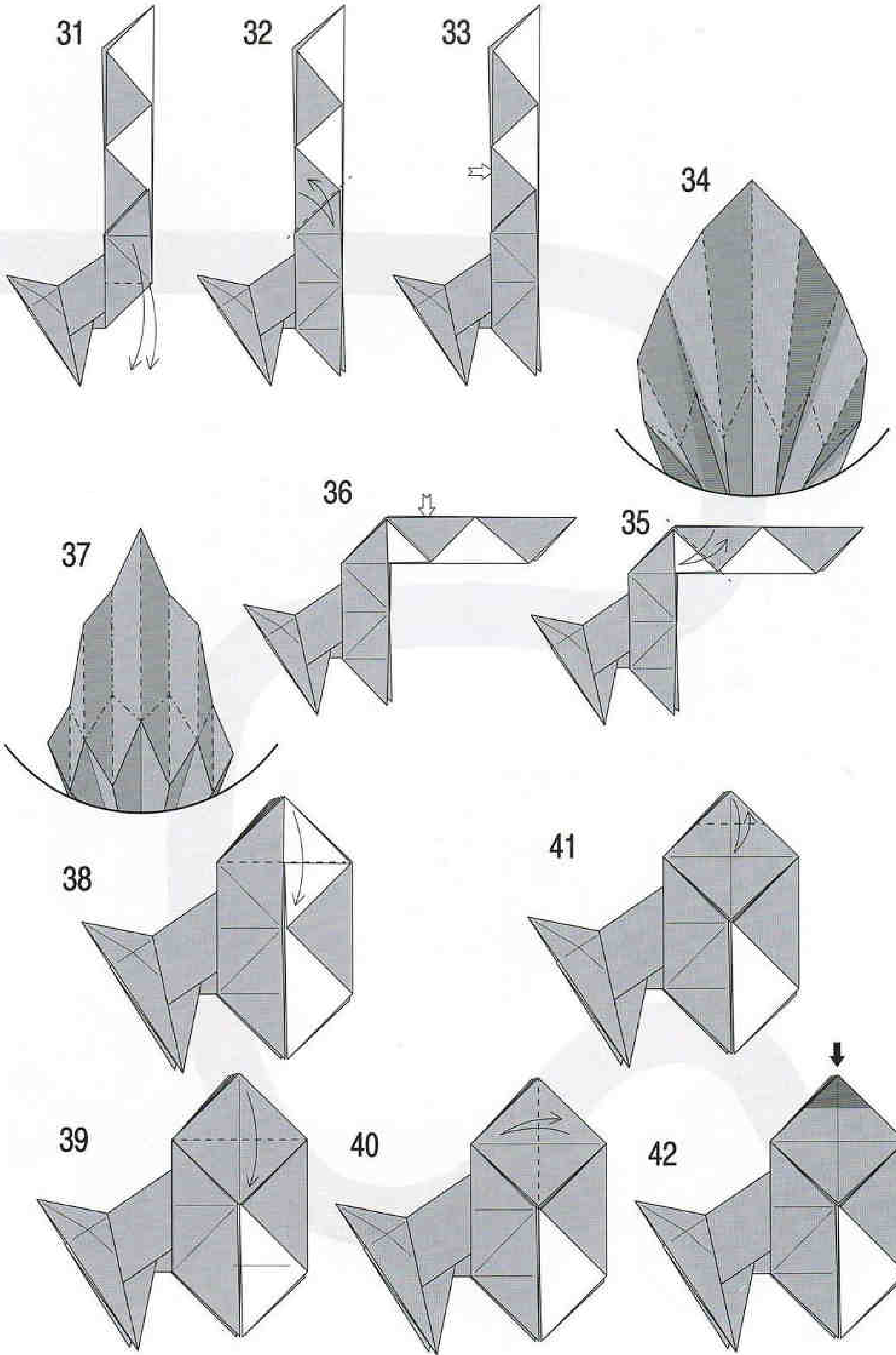

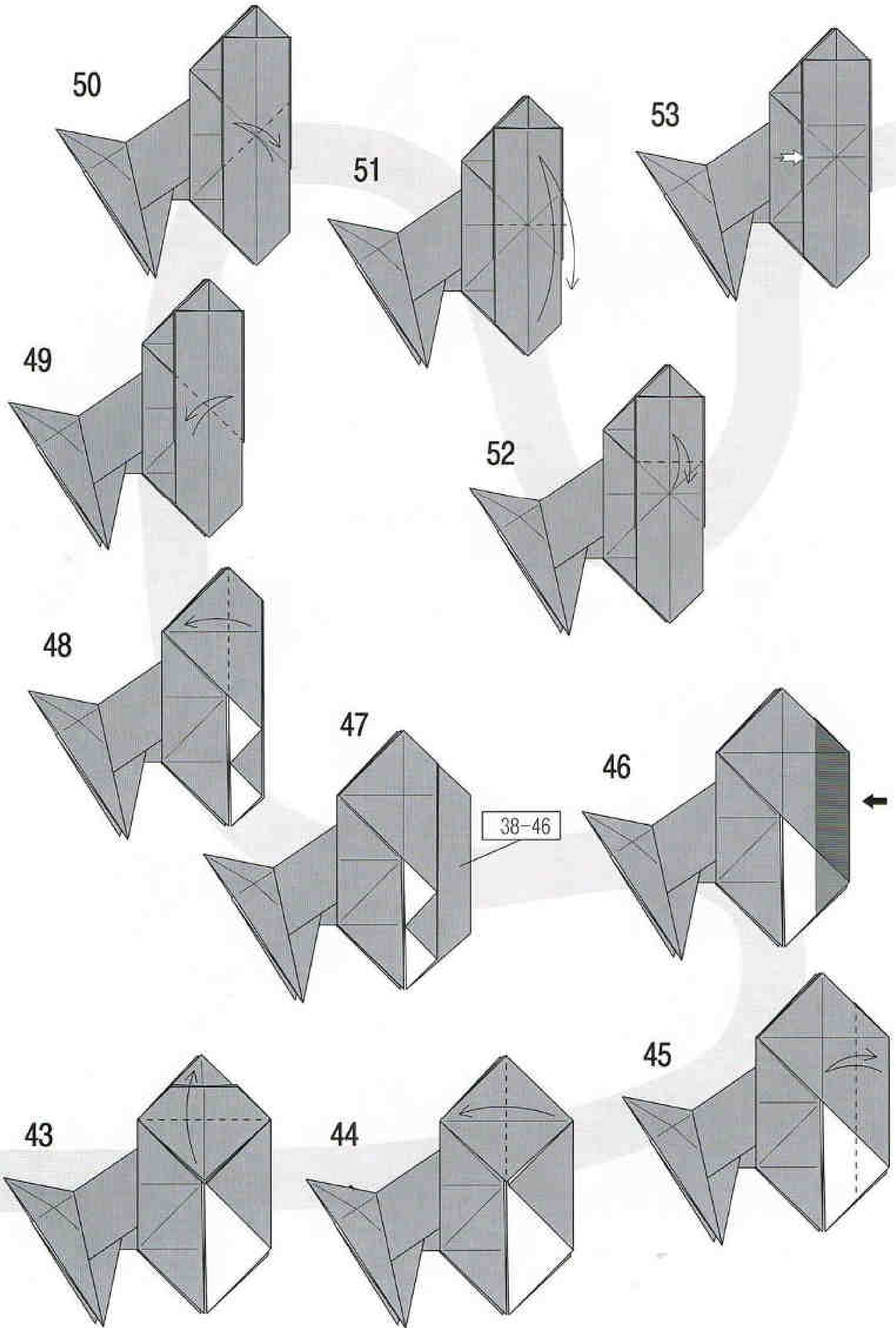

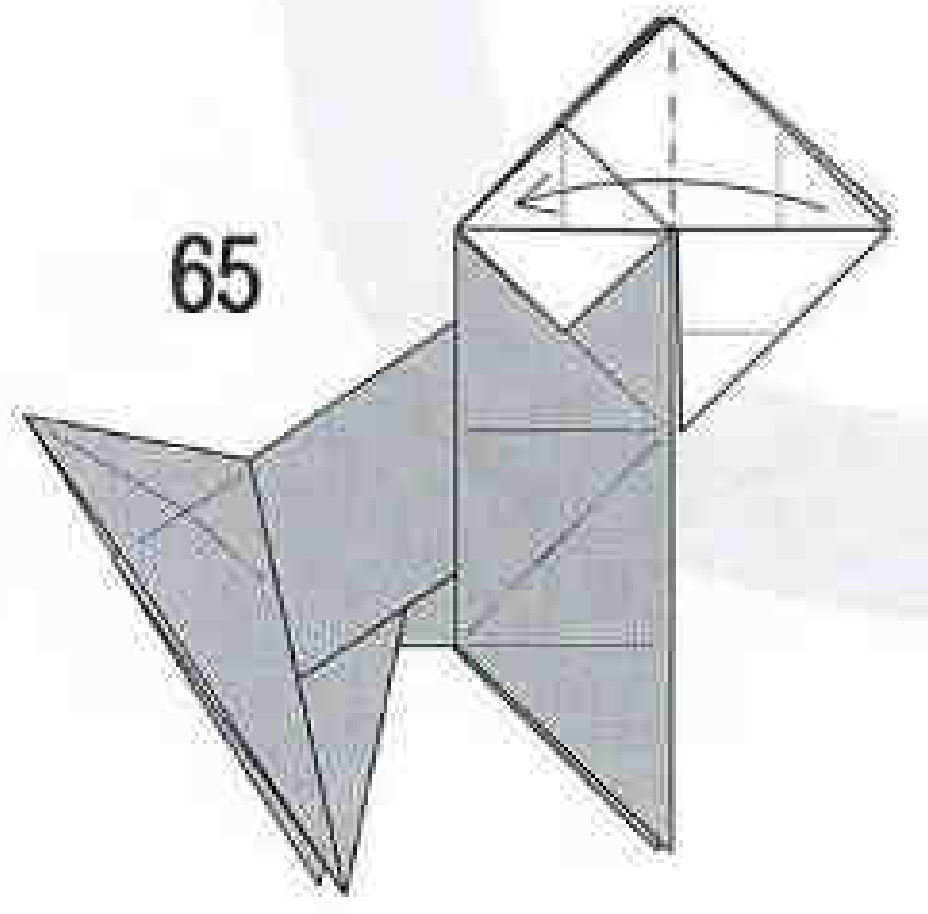
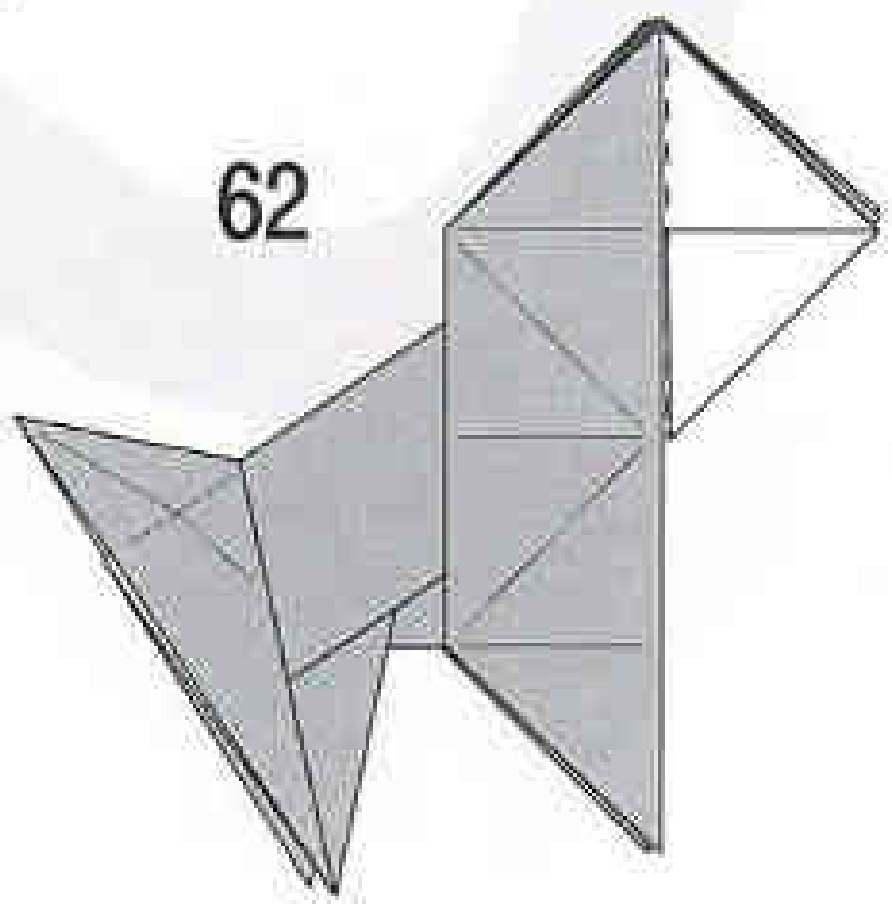
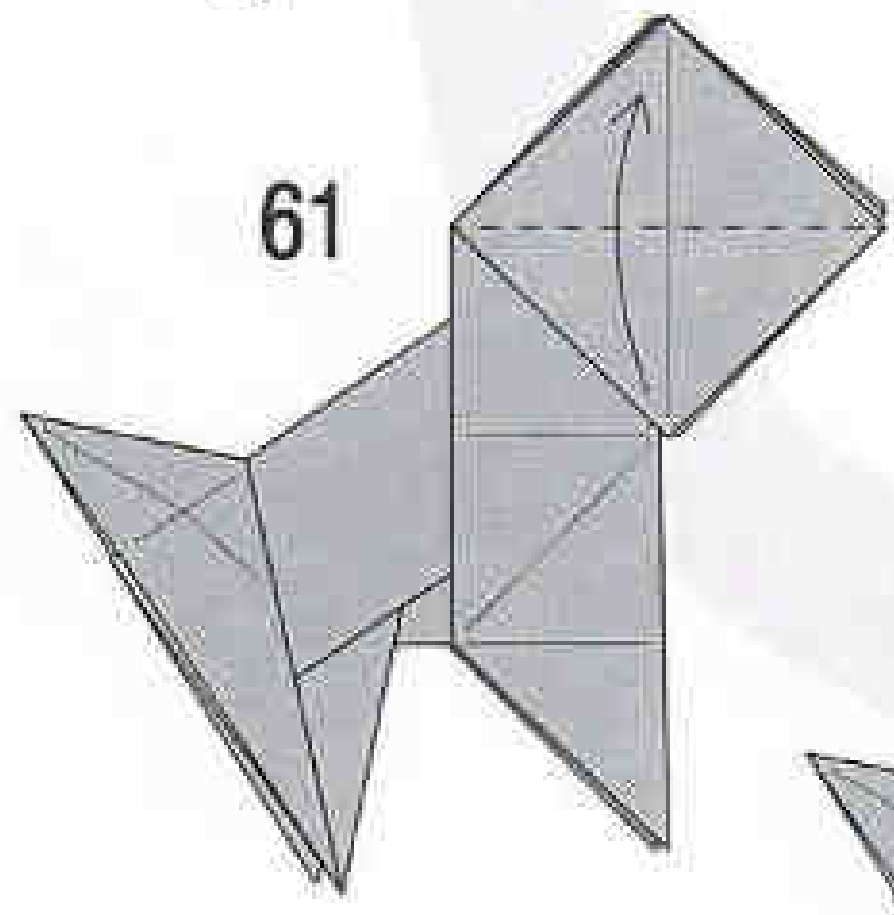
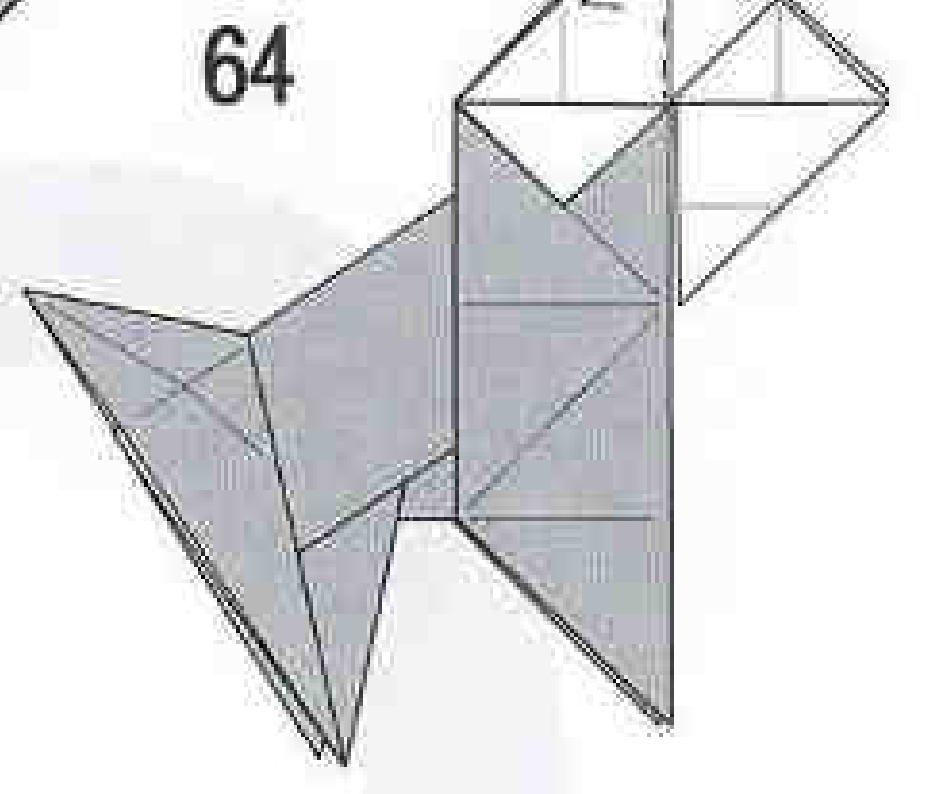
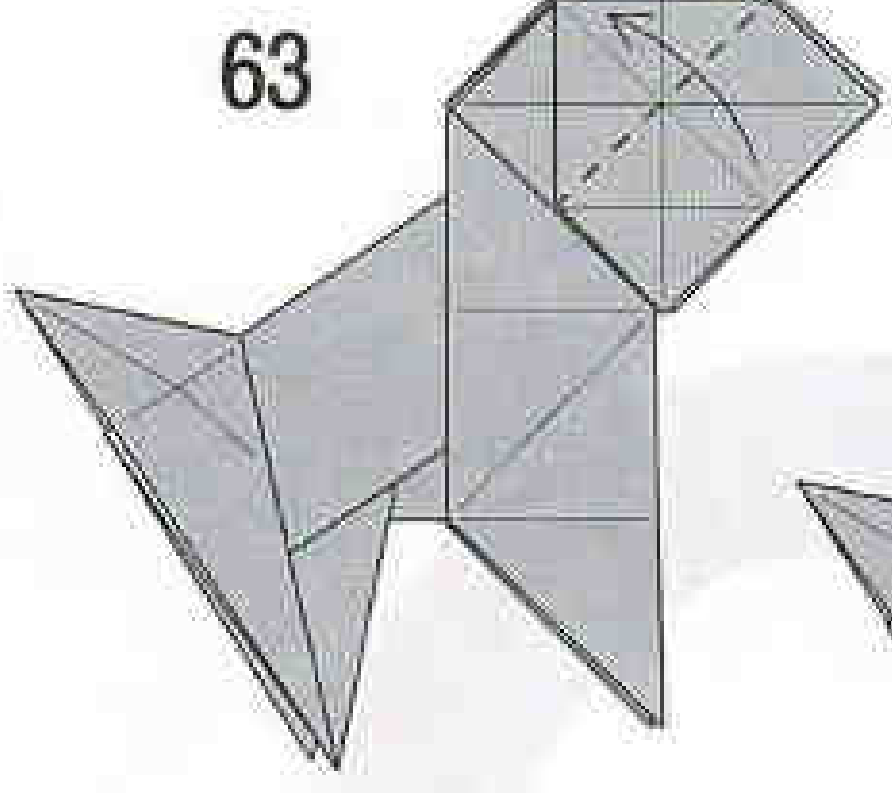
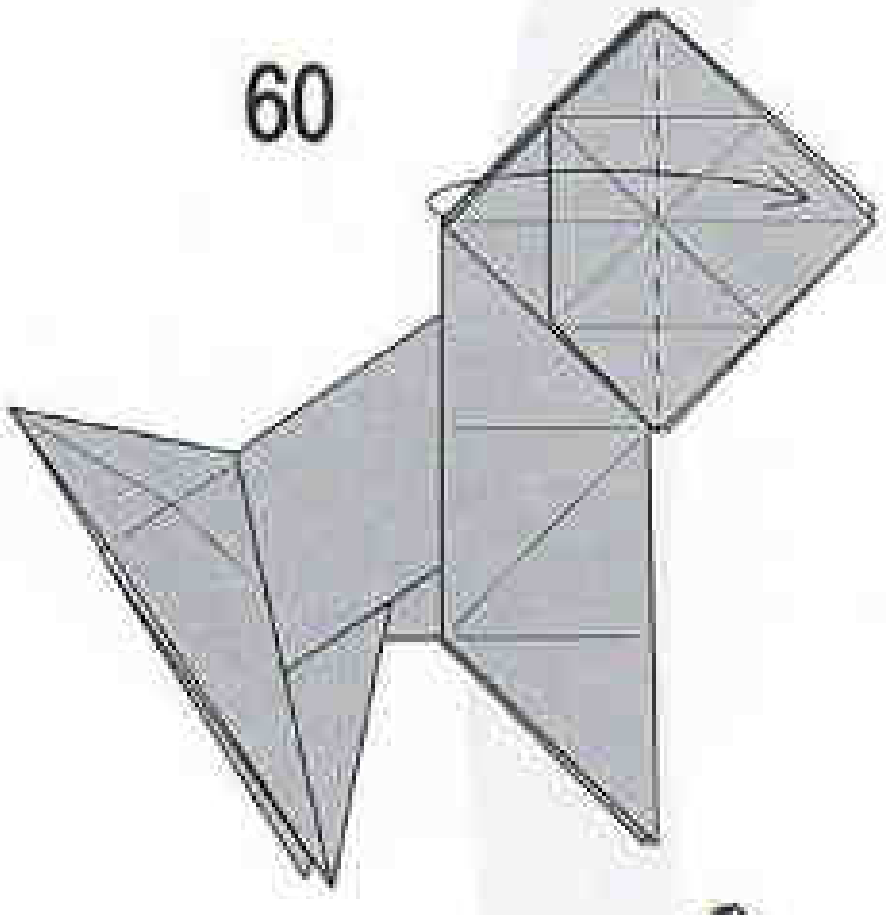
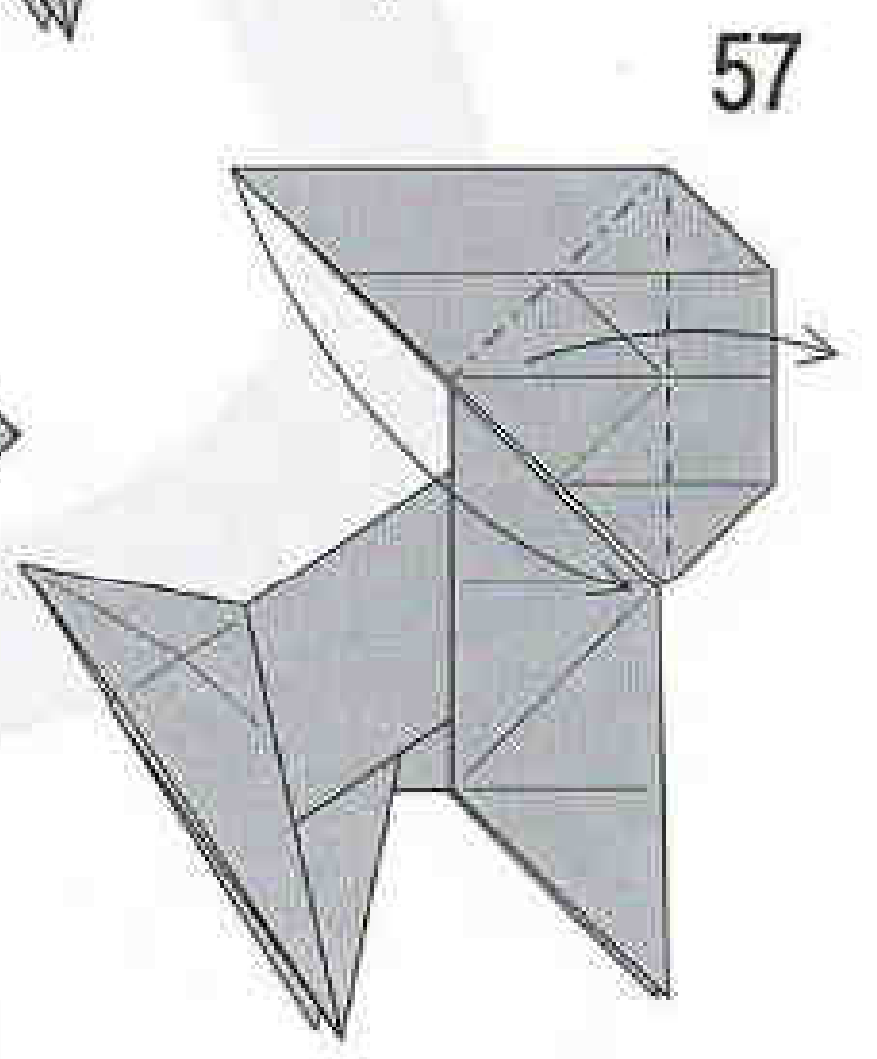
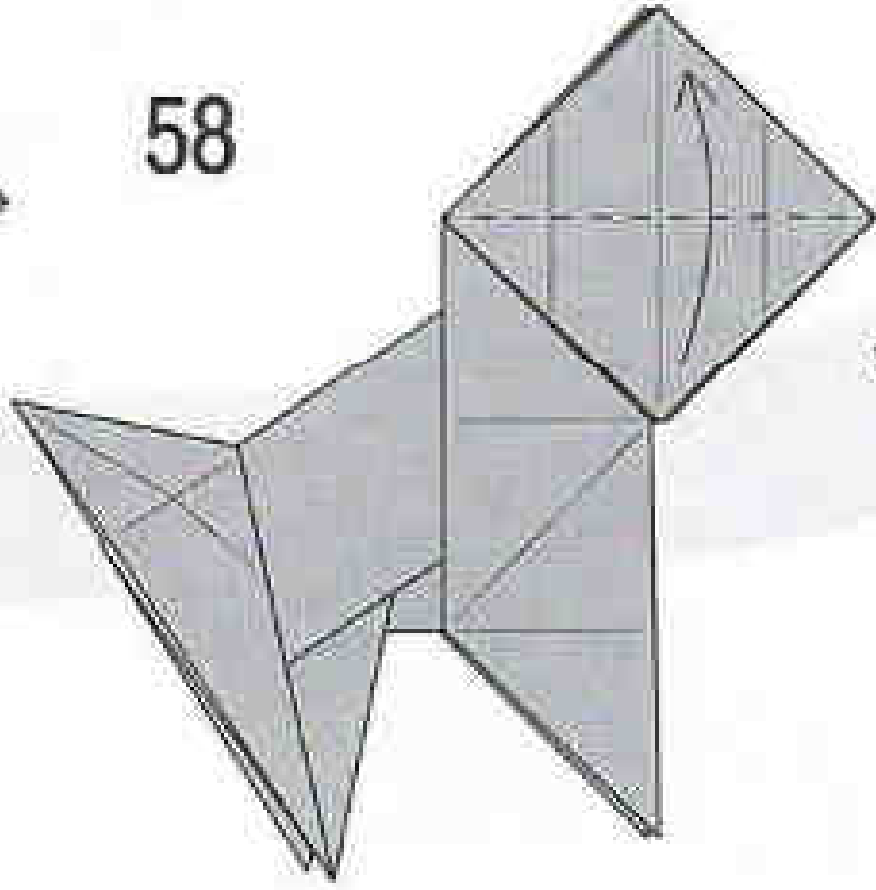
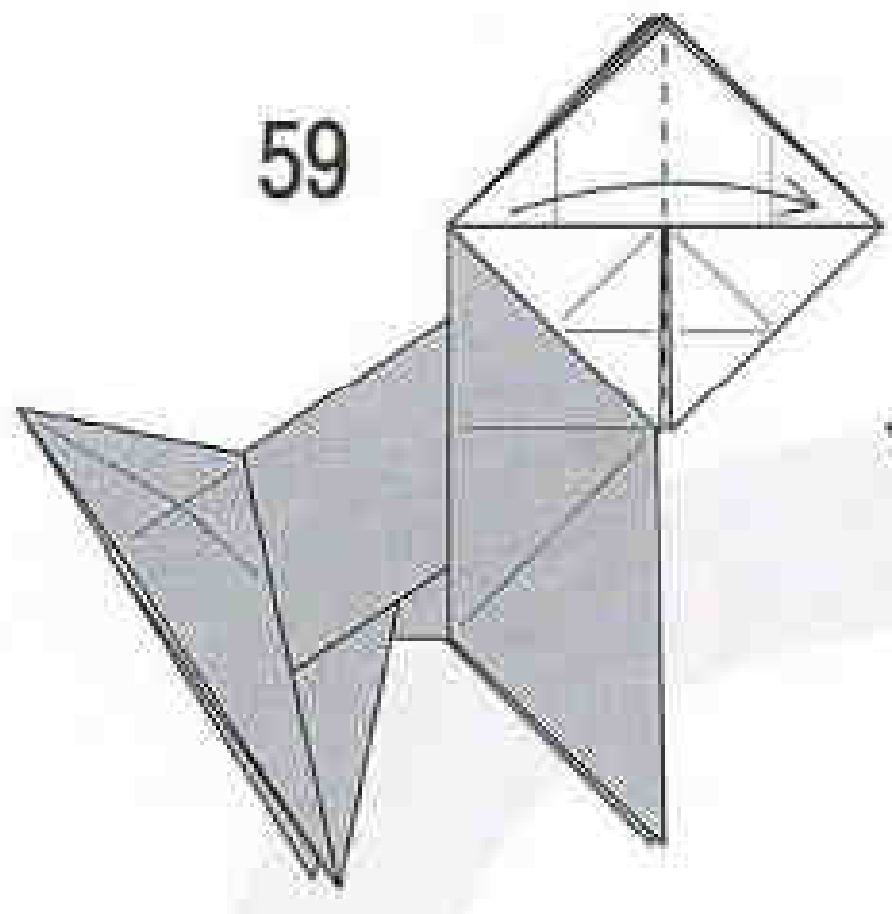
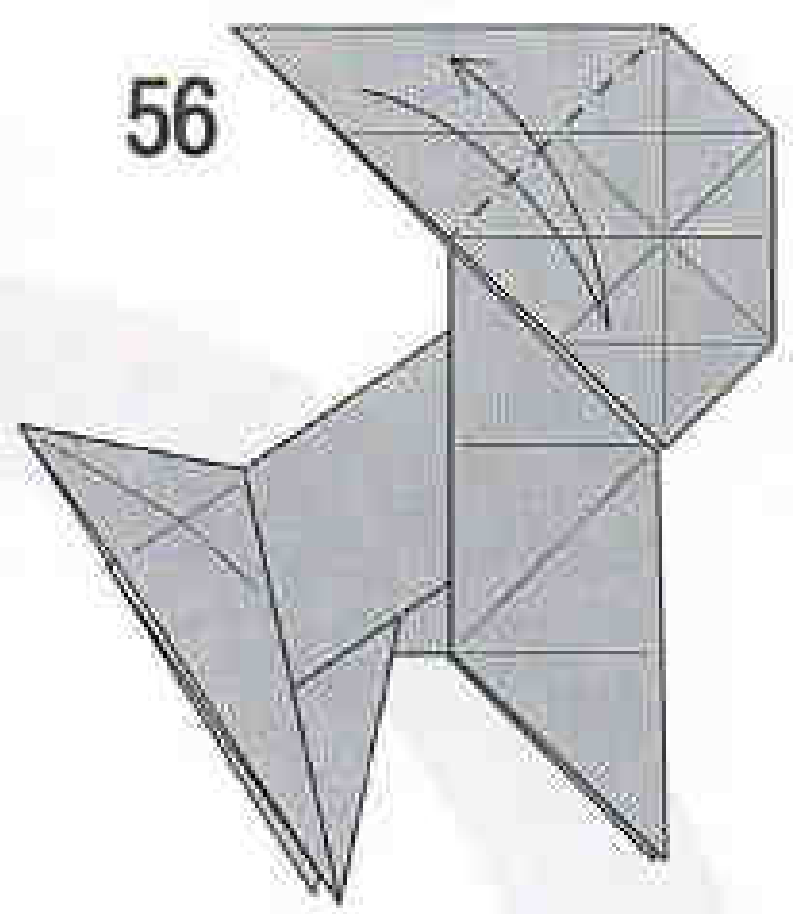
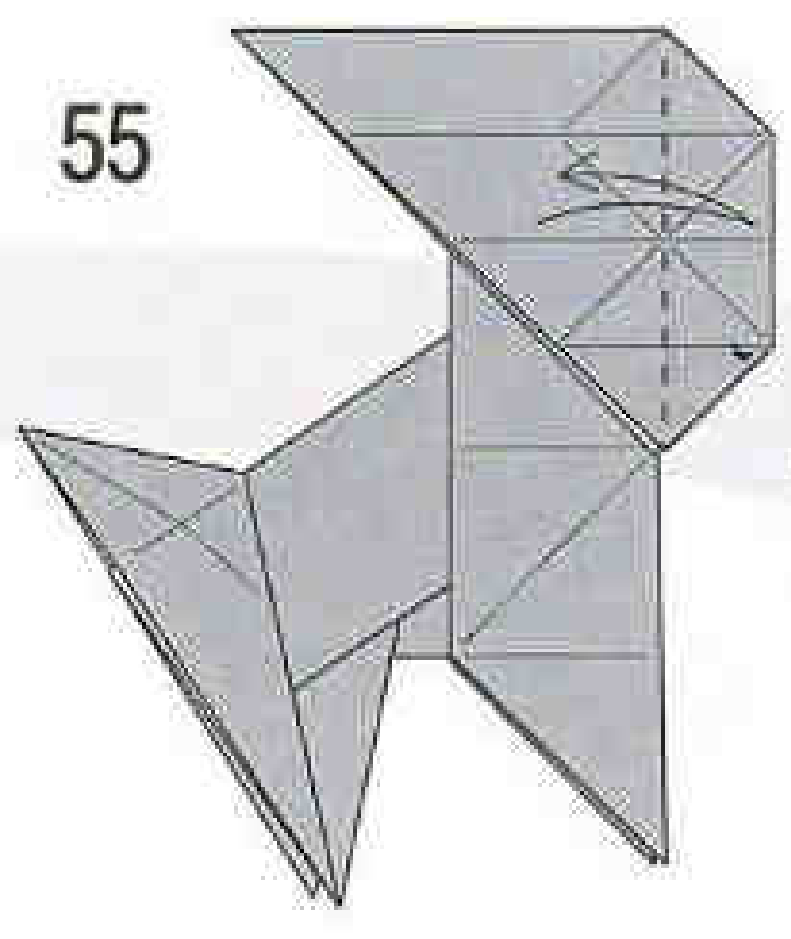
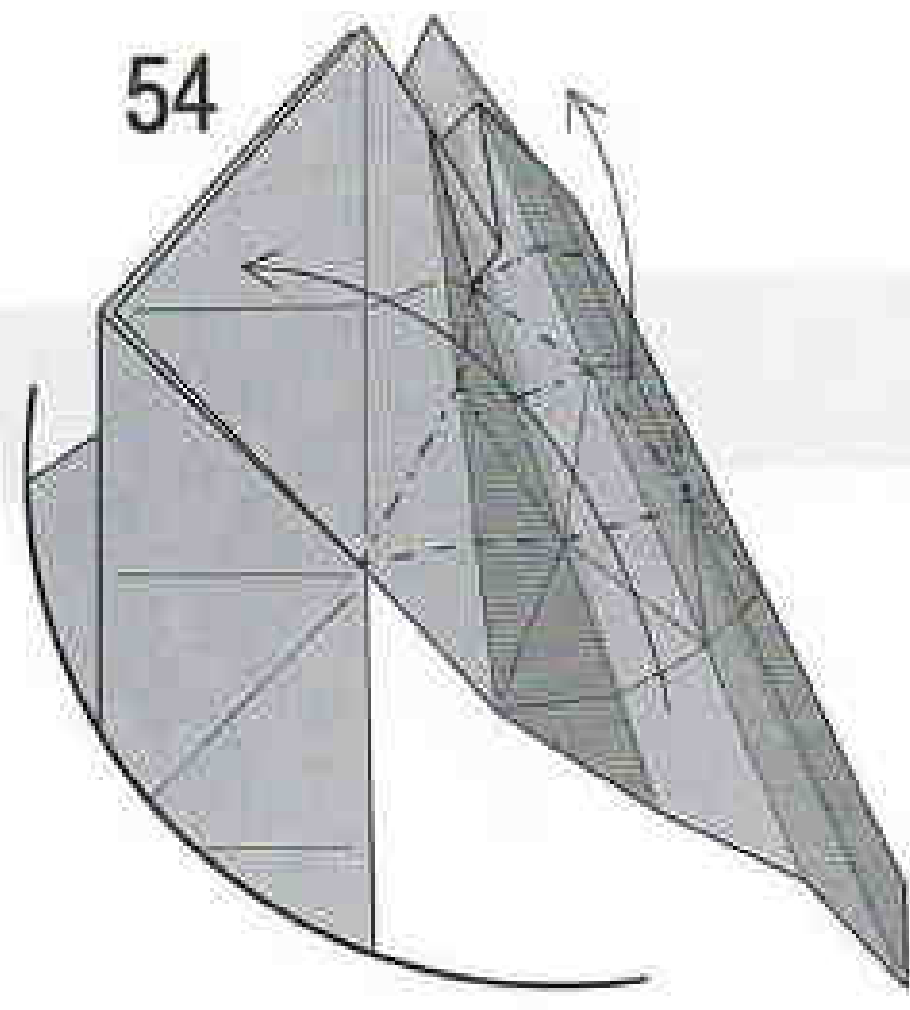

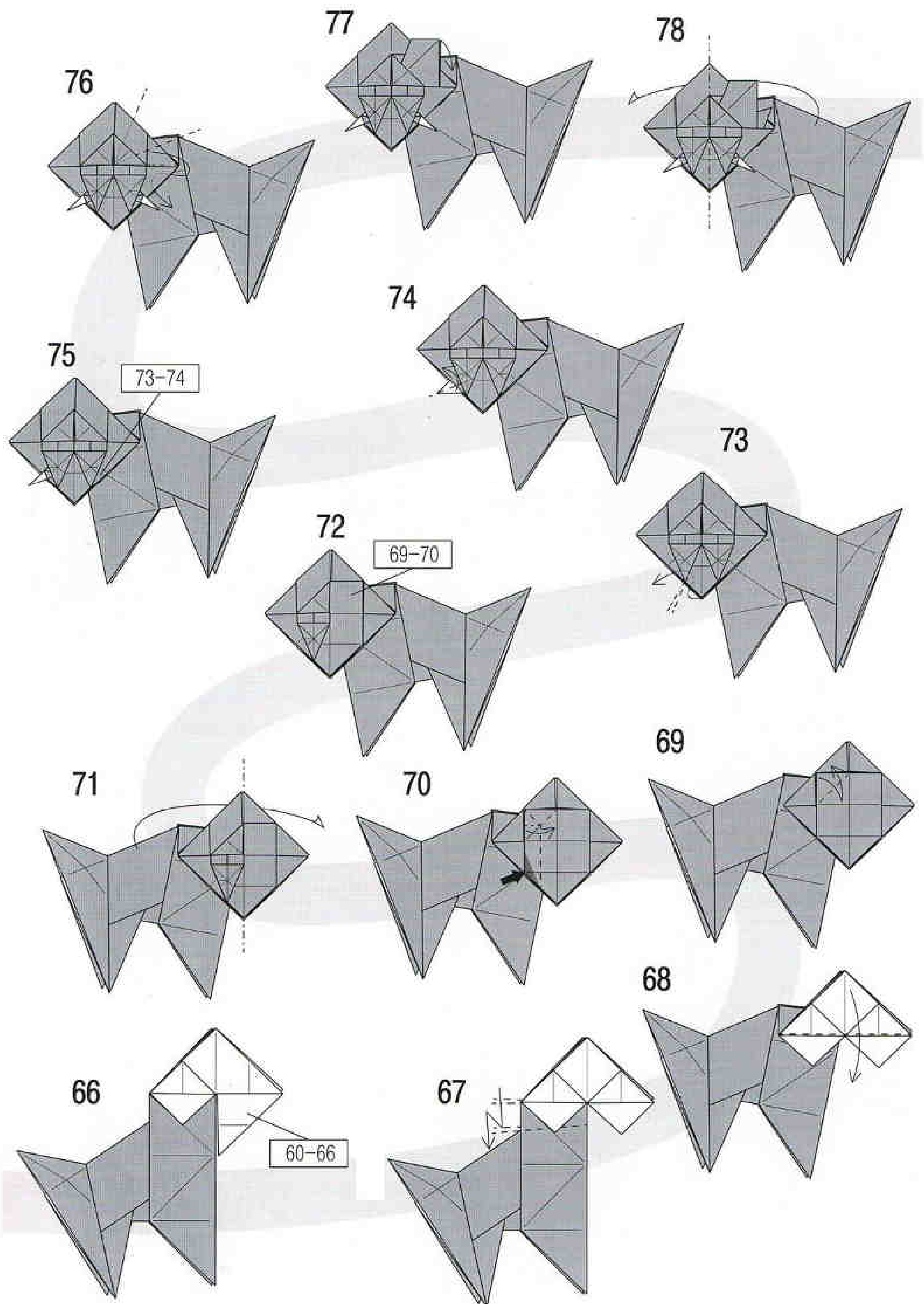

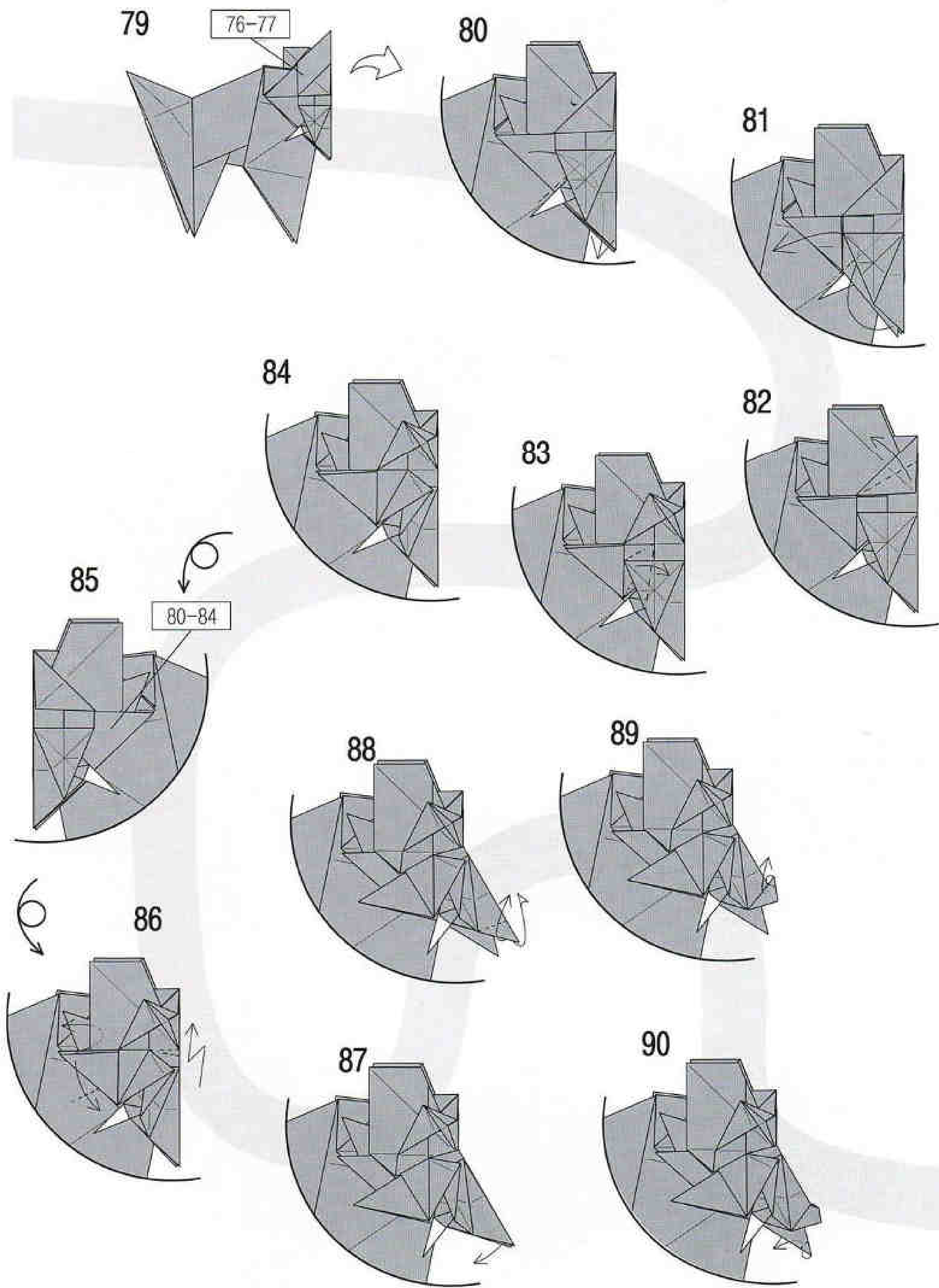

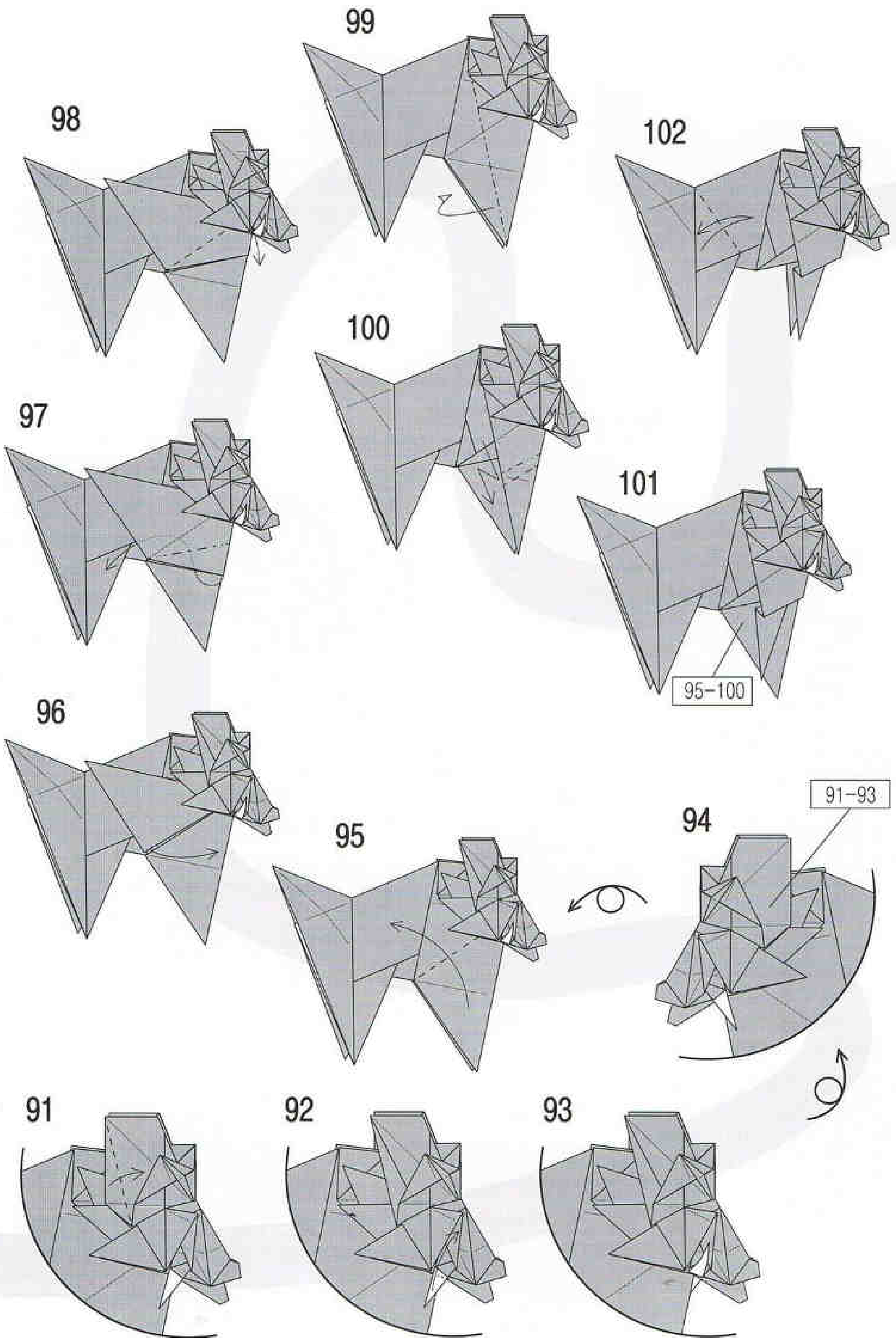

103

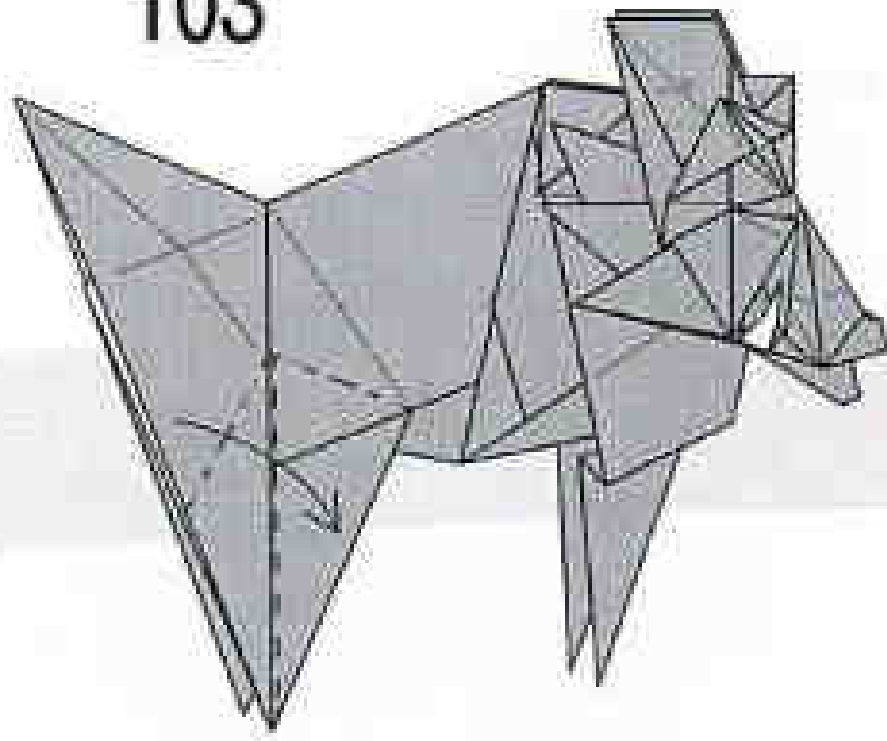

104

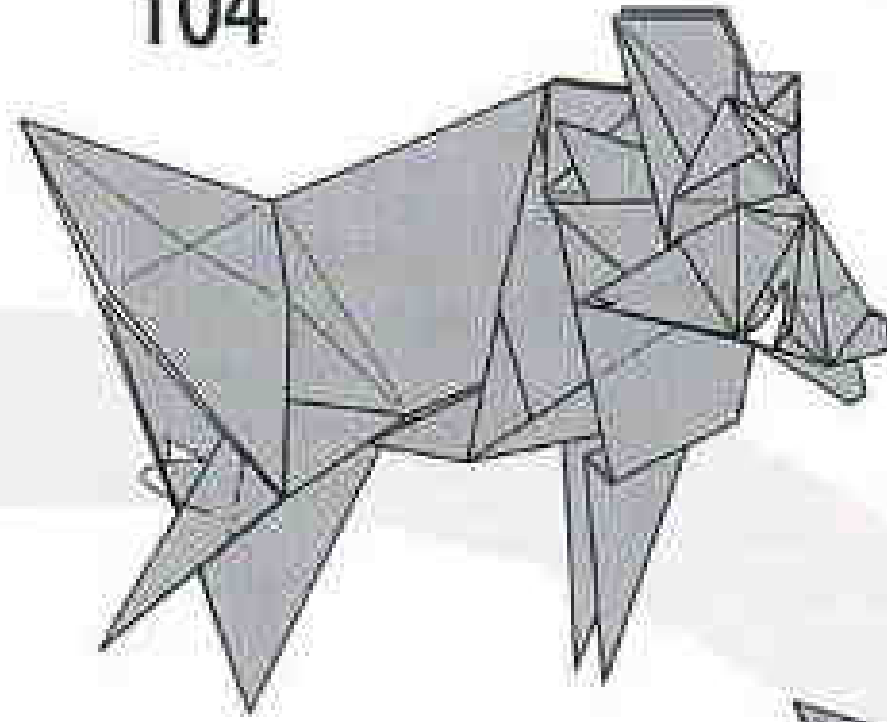

105

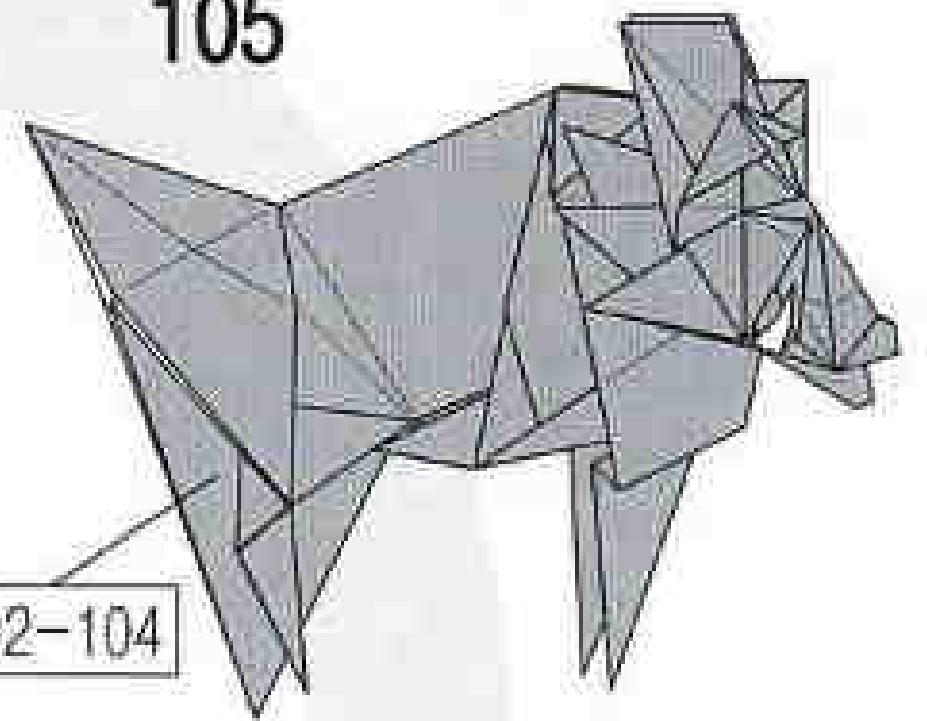

107

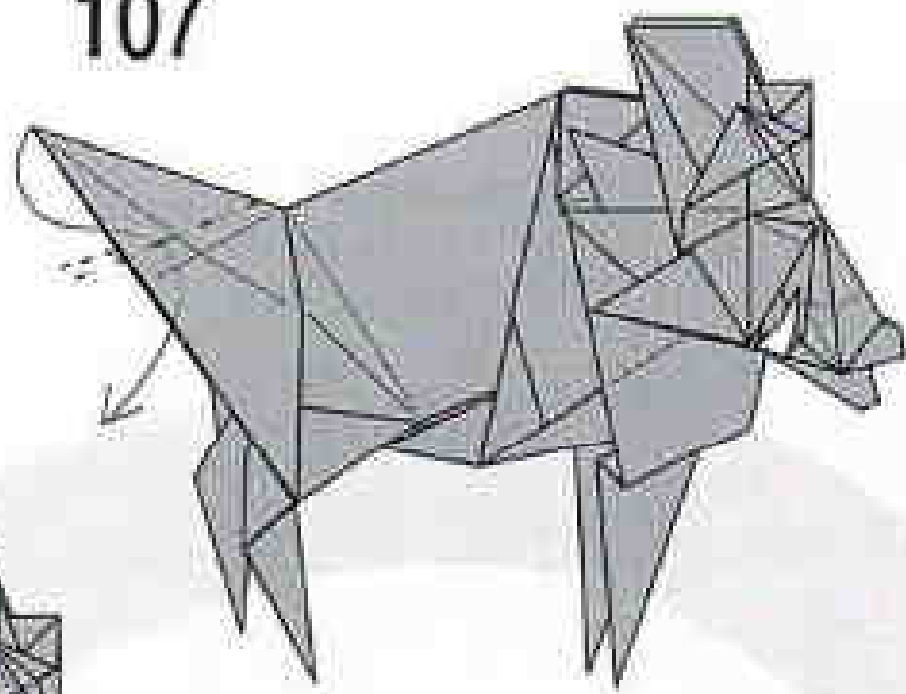

106

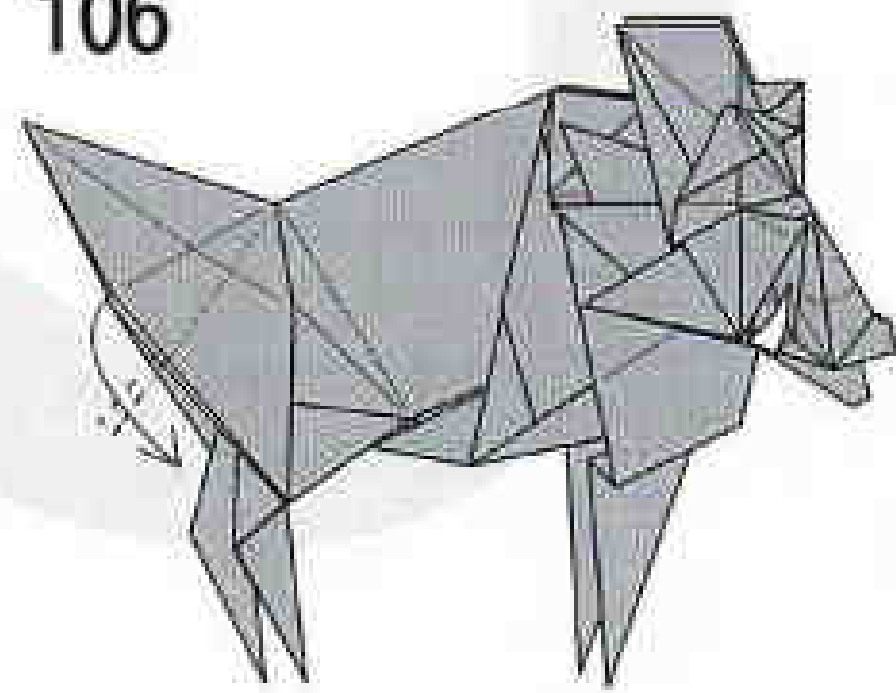

108

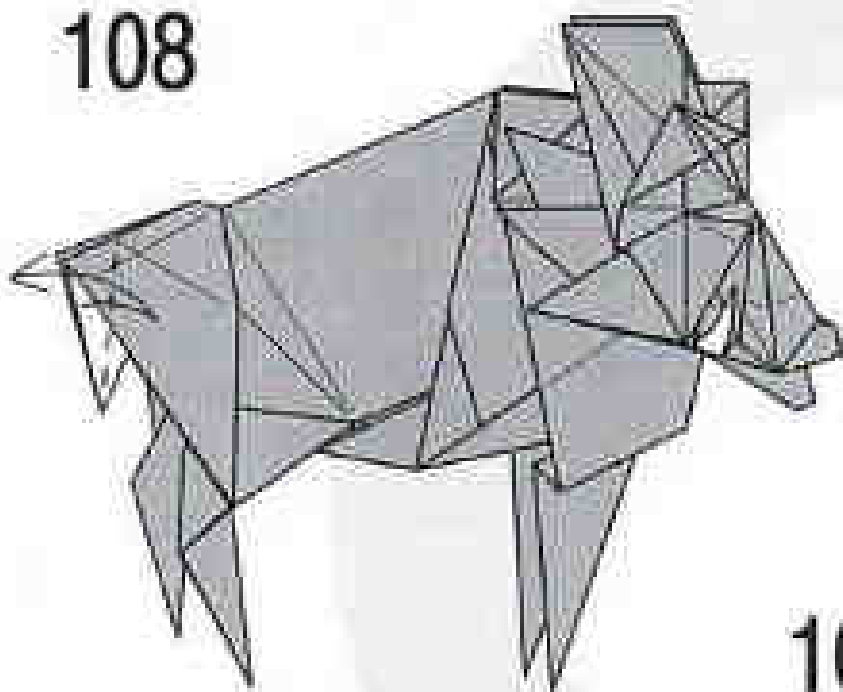

109

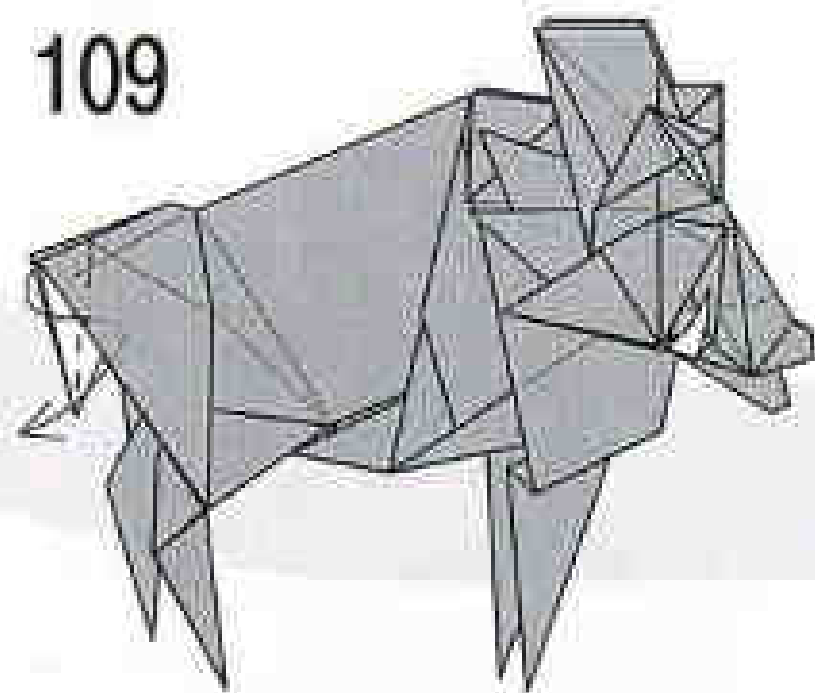

110

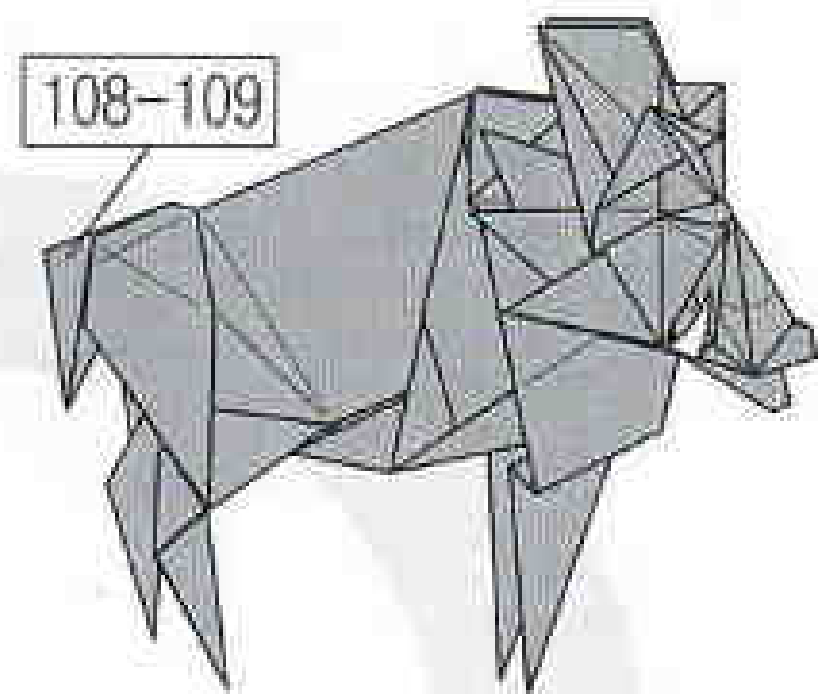

완성

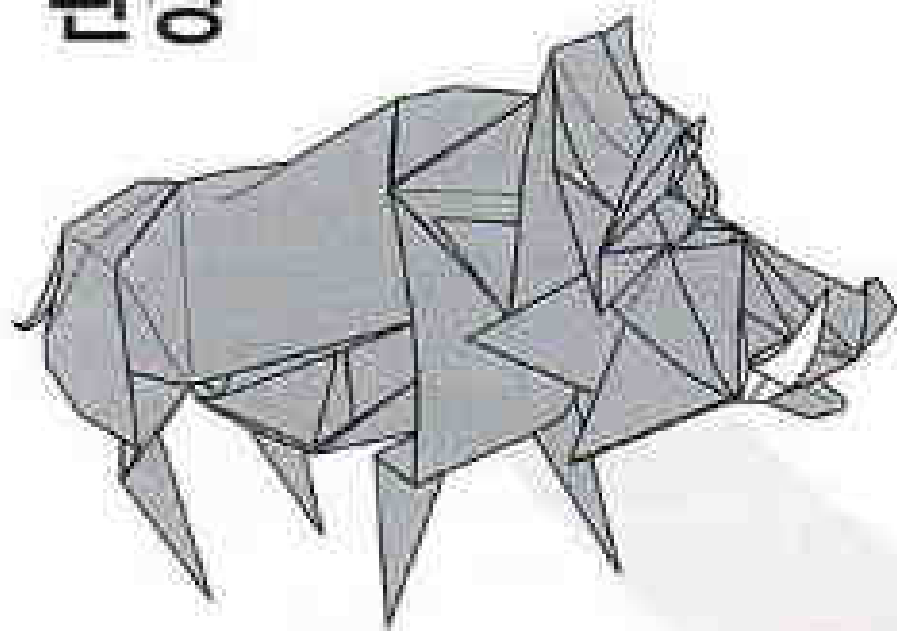

112

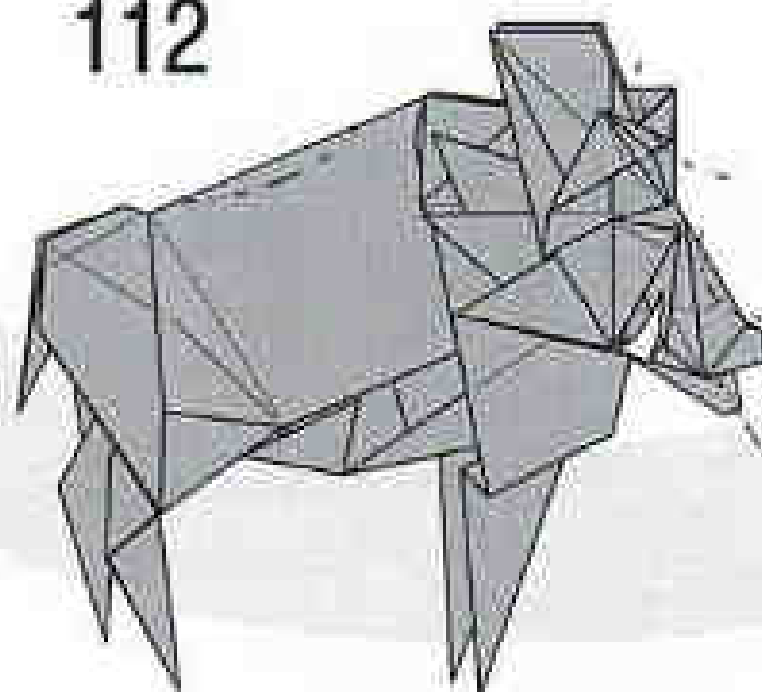

111

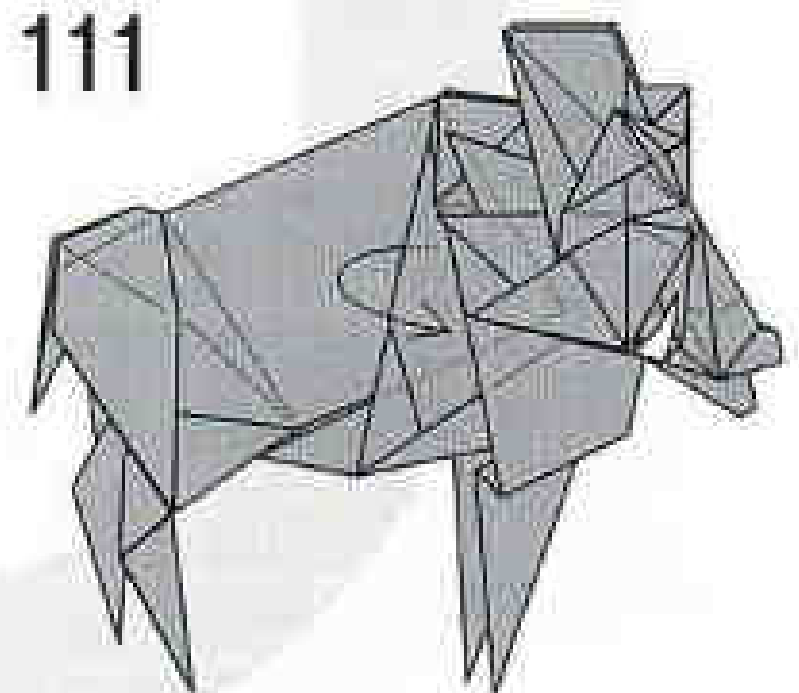

바깥으로 빼내어 끼워넣습니다.

먹이사슬 (Food Chain)

창작가 : 장용익 (Jang Yong Ik)

다이어그램 : 장용익 (Jang Yong Ik)

창작일 : 2015.06.20

종이크기 : 140cm x 140cm

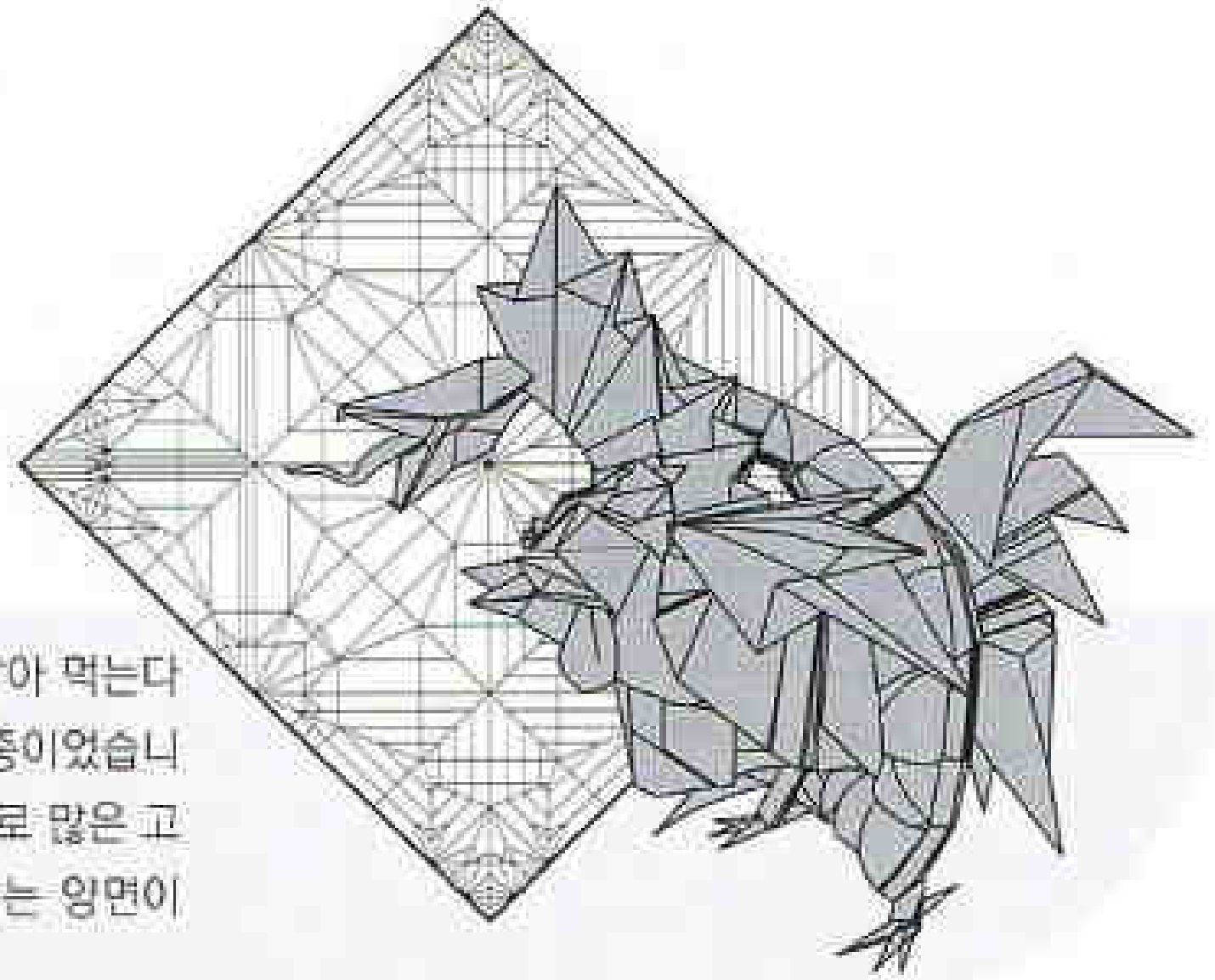

최근까지 시골에 거주중이었습니다. 그곳에서 어릴적부터 닭이 뱀을 잡아 먹는다 는 이야기를 많이 들어왔는데 언젠가 꼭 접어볼 주제로 오랫동안 생각중이었습니다. 뱀과 닭을 한꺼번에 접기 위한 자연스러운 설계를 위해서 구조적으로 많은 고민을 했습니다. 결과적으로 성공했지만 실제로 접어 완성하기 위해서는 양면이 같은 색인 큰 종이가 필요합니다.

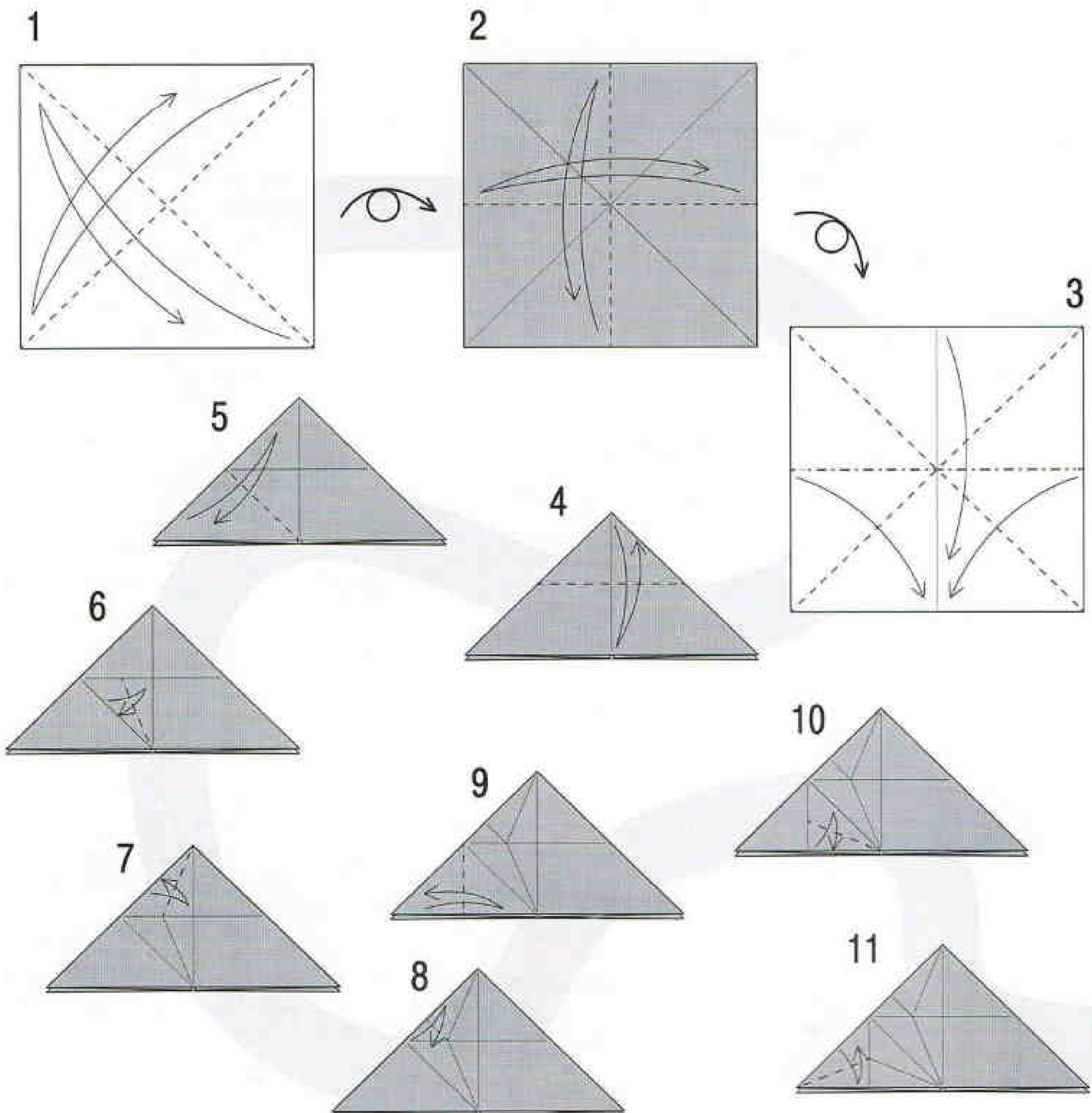

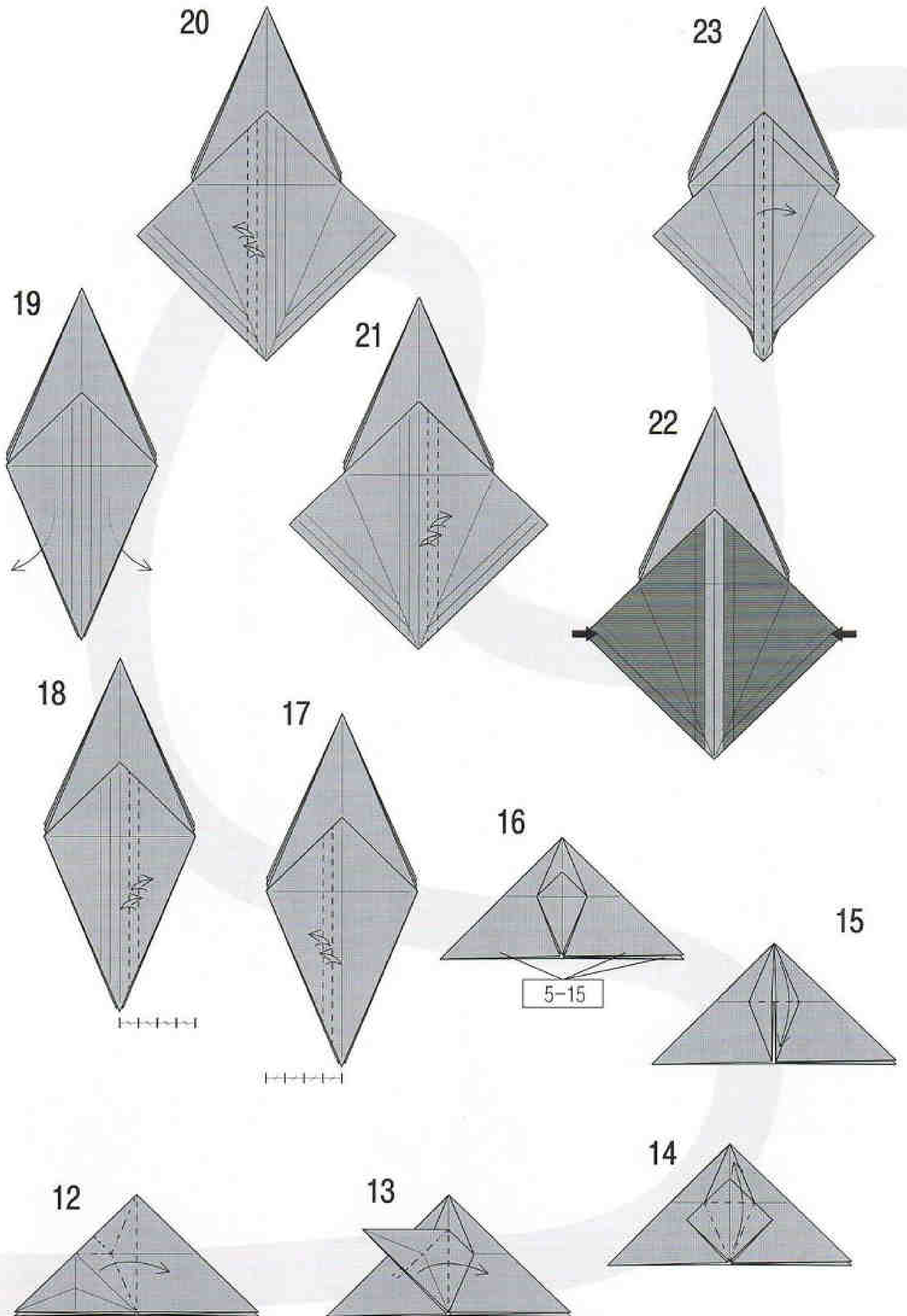

24

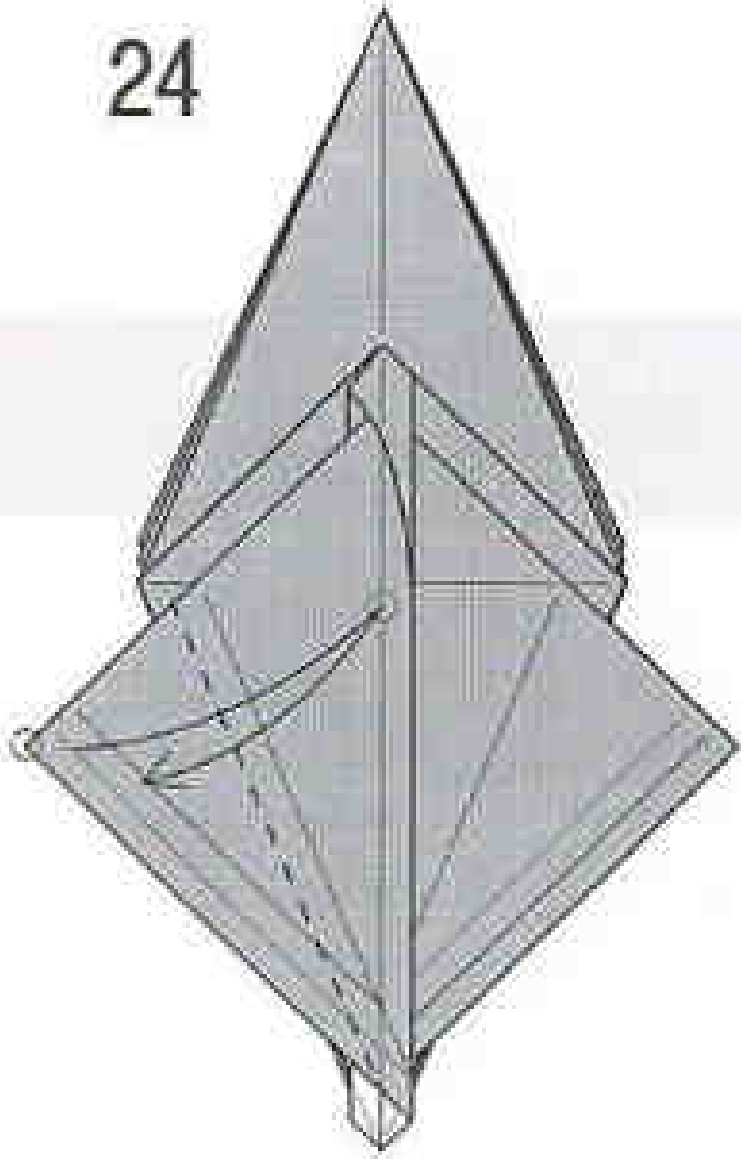

25

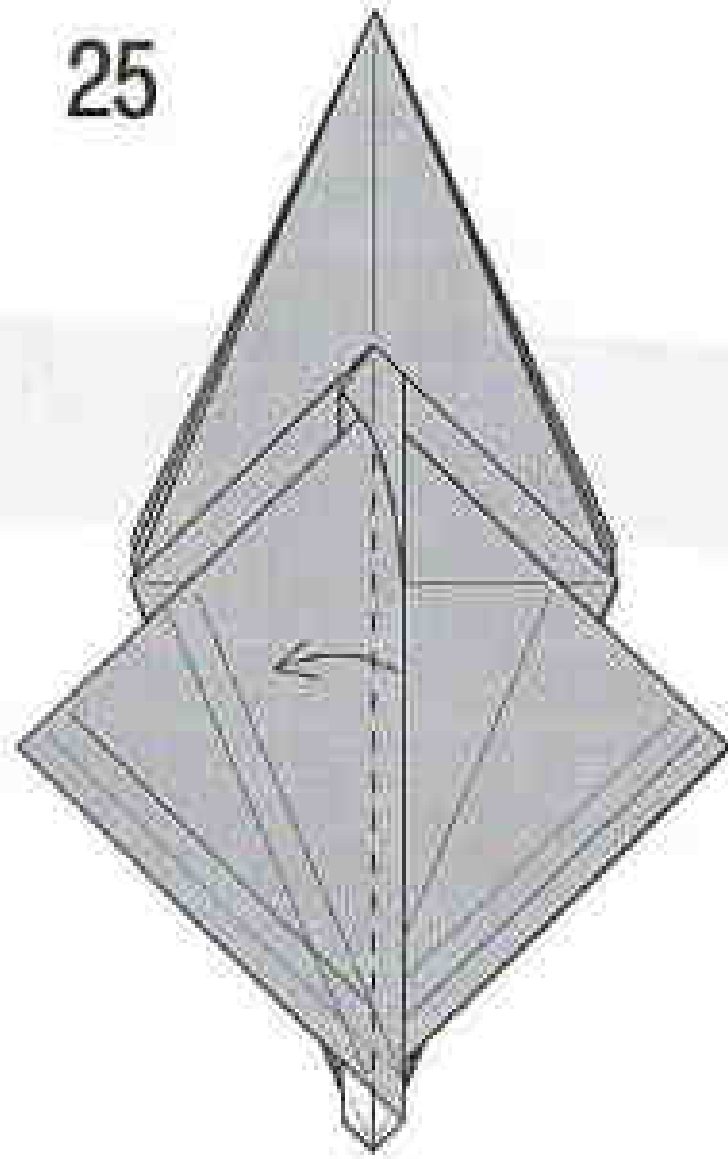

26

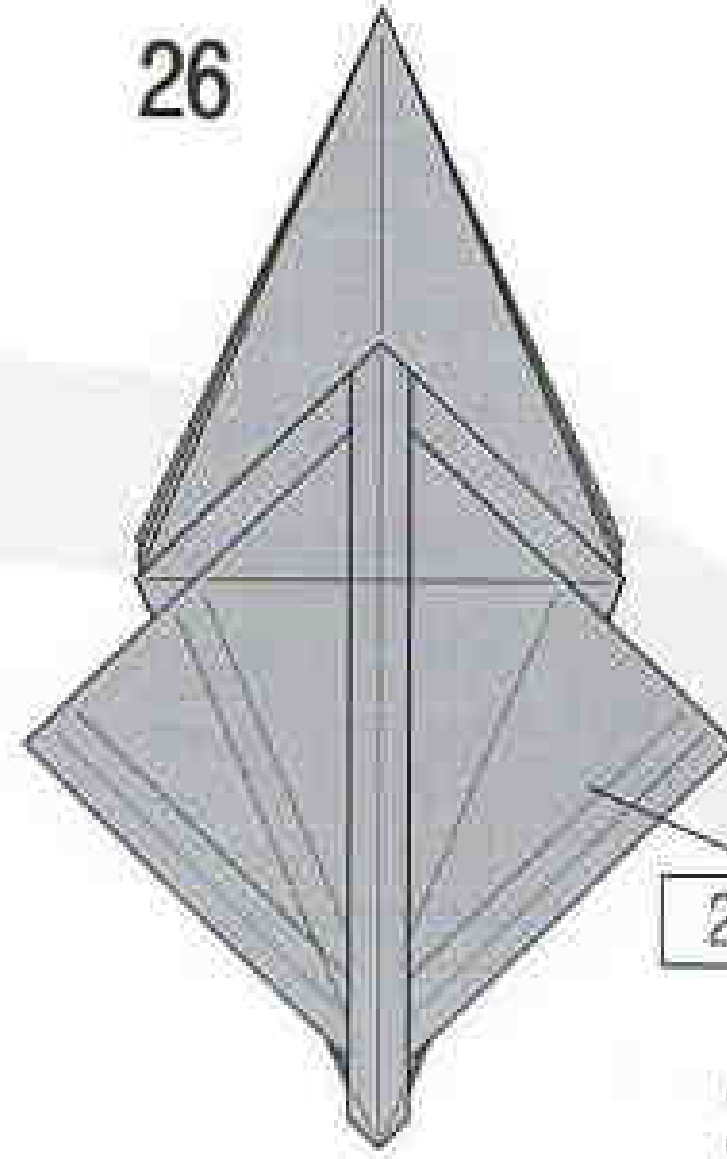

23-25

27

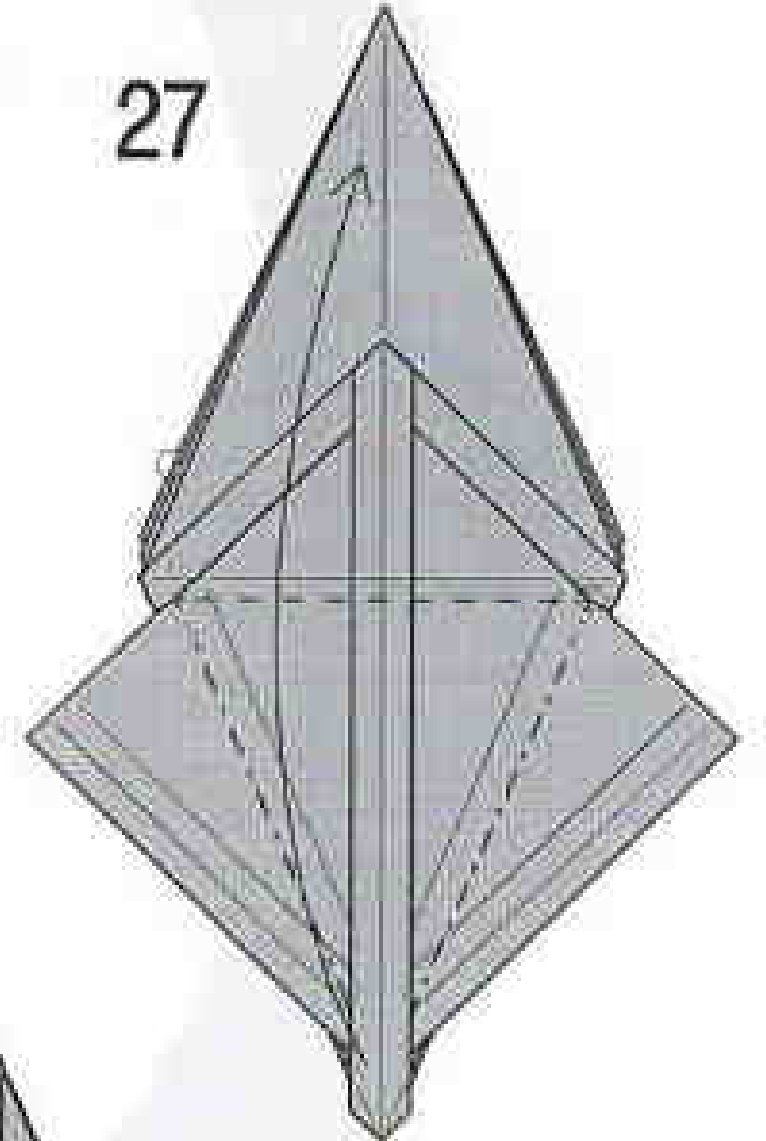

29

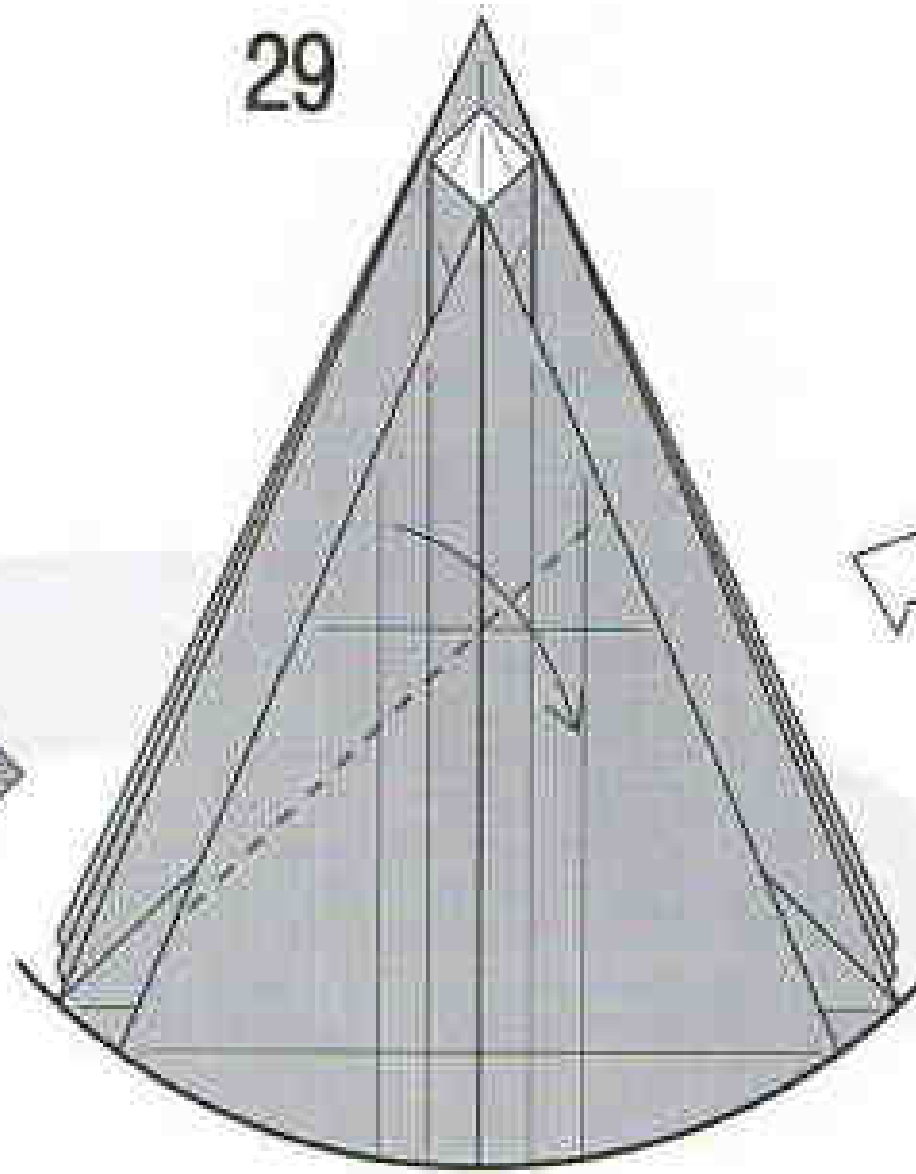

28

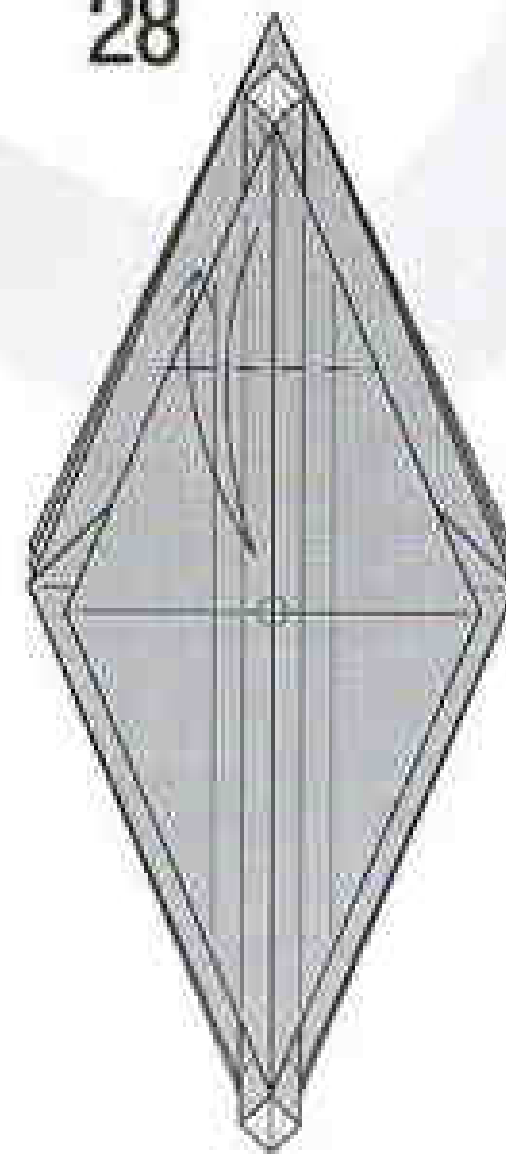

30

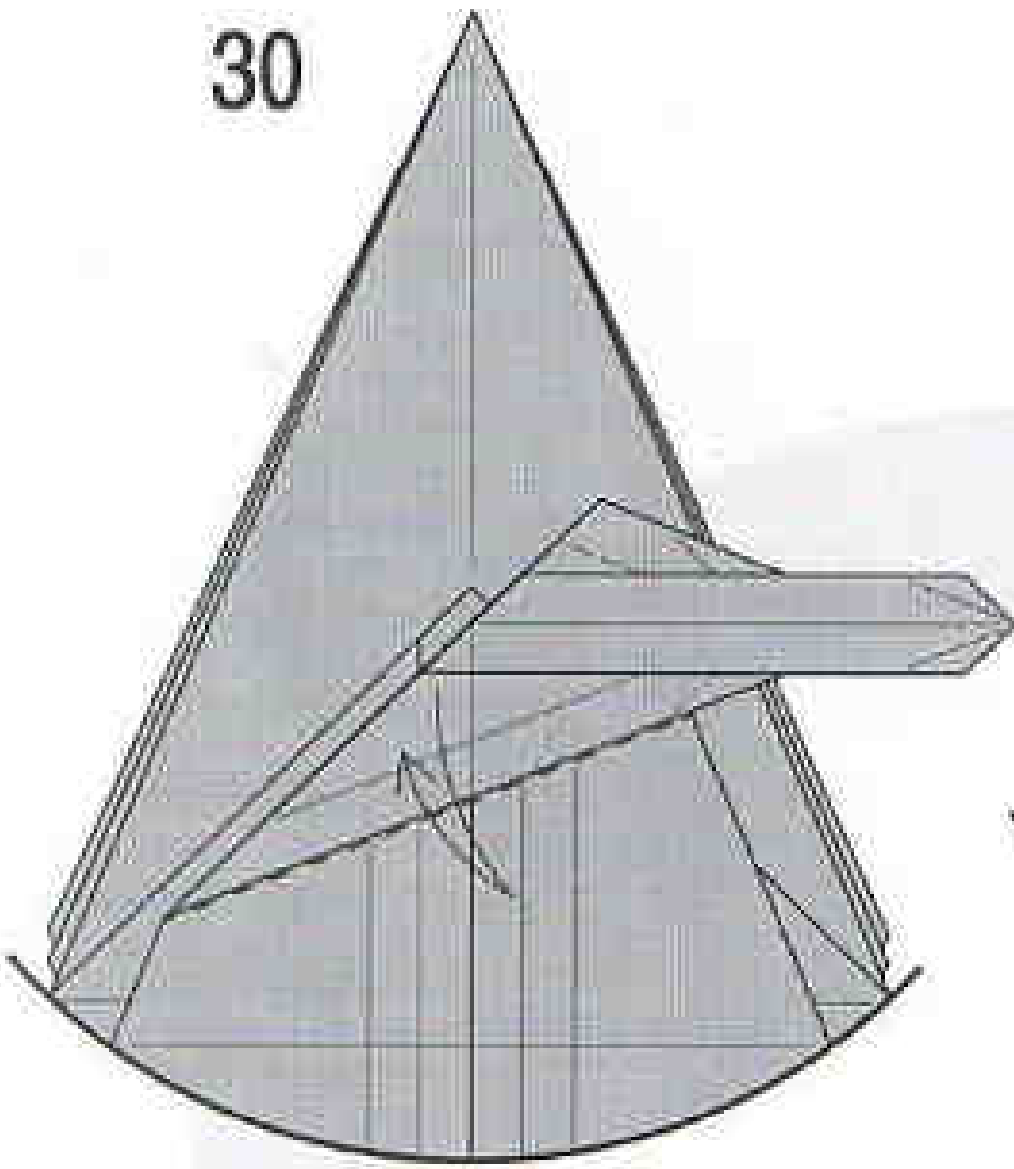

31

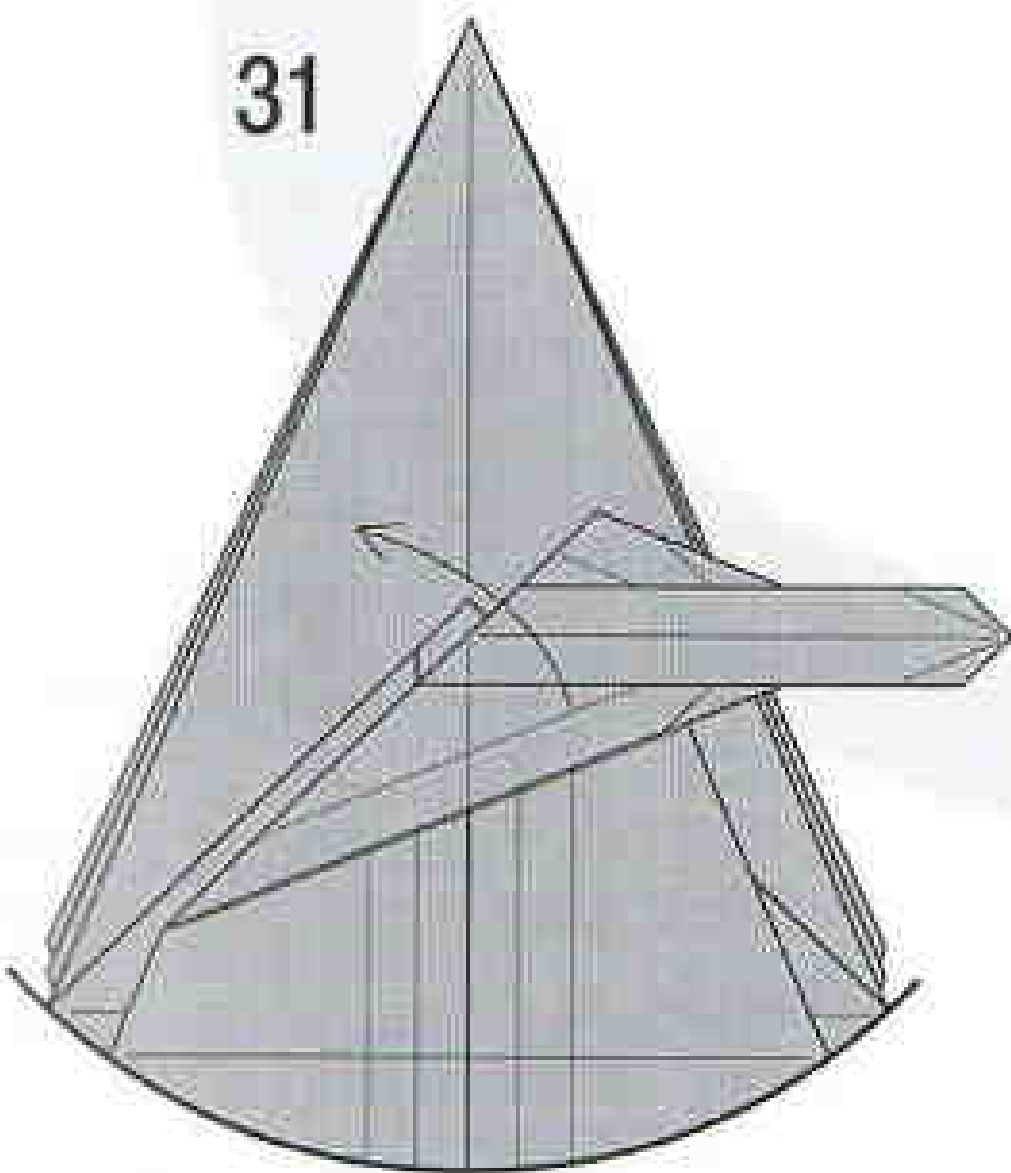

32

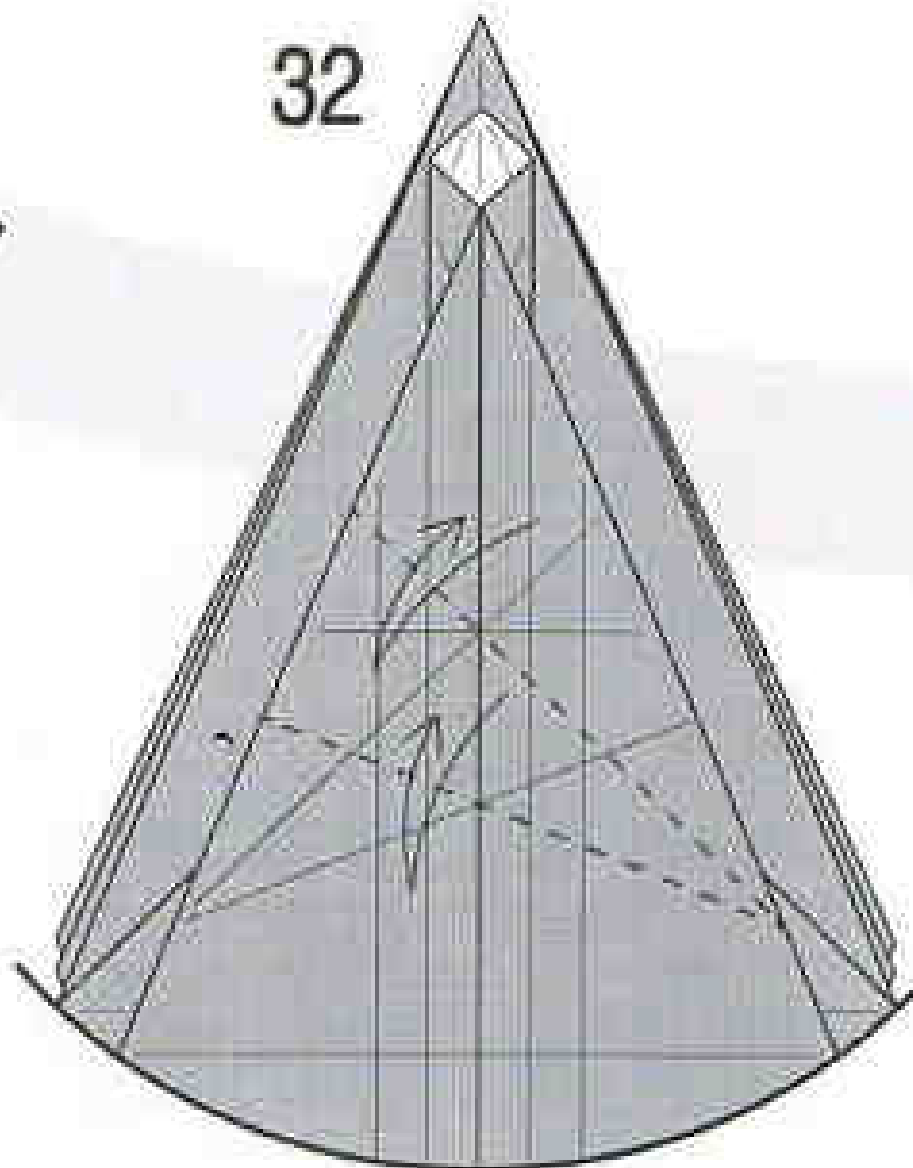

33

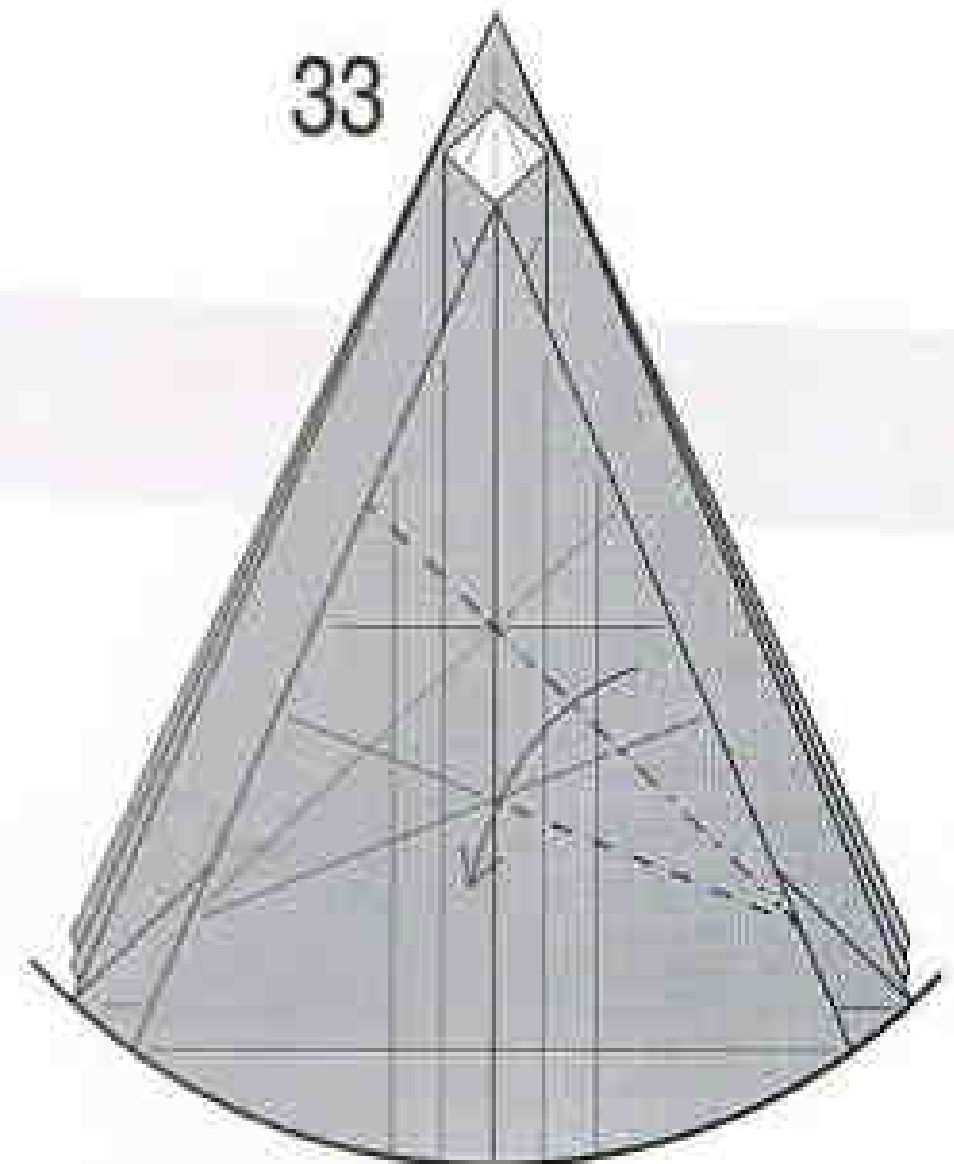

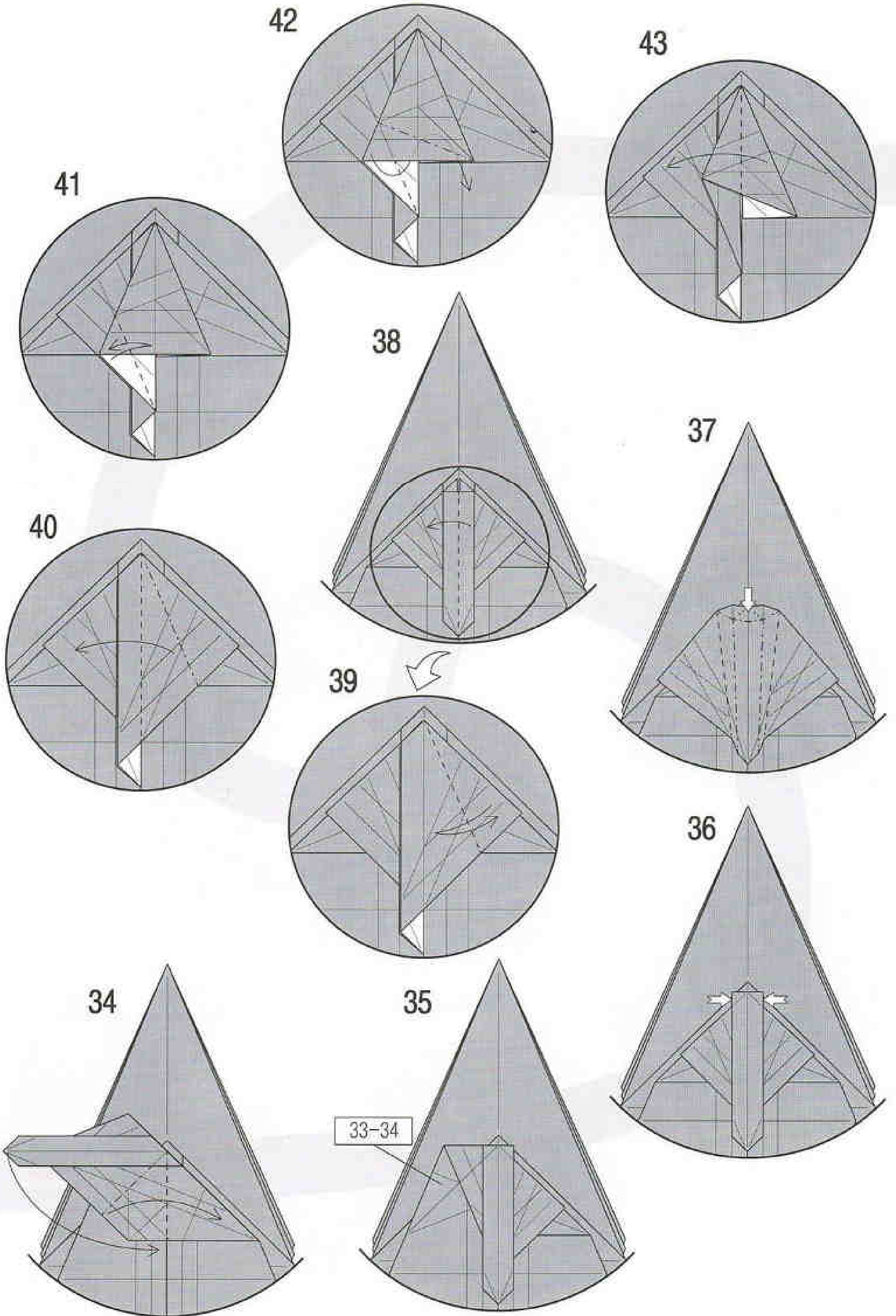

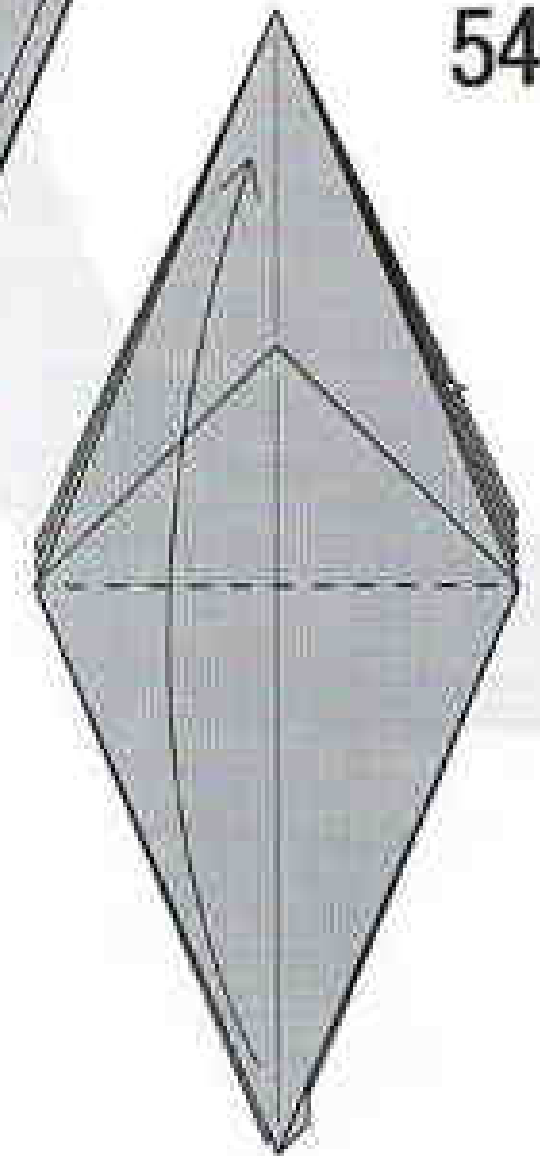
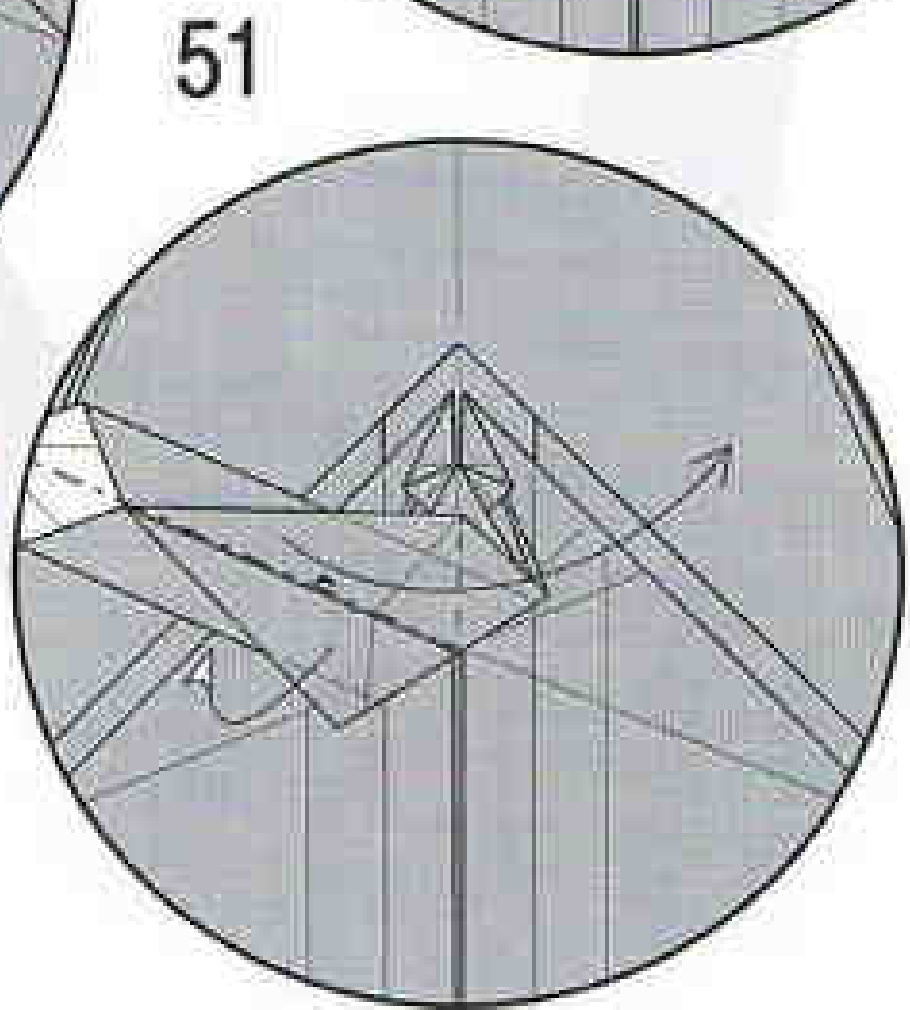
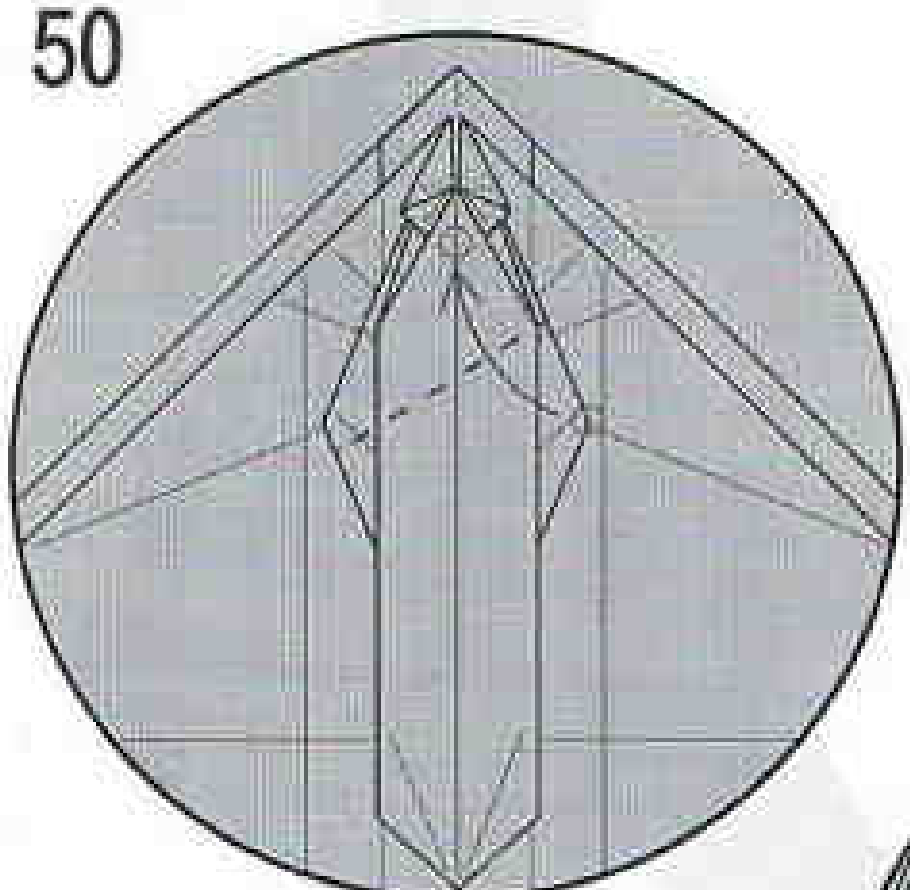
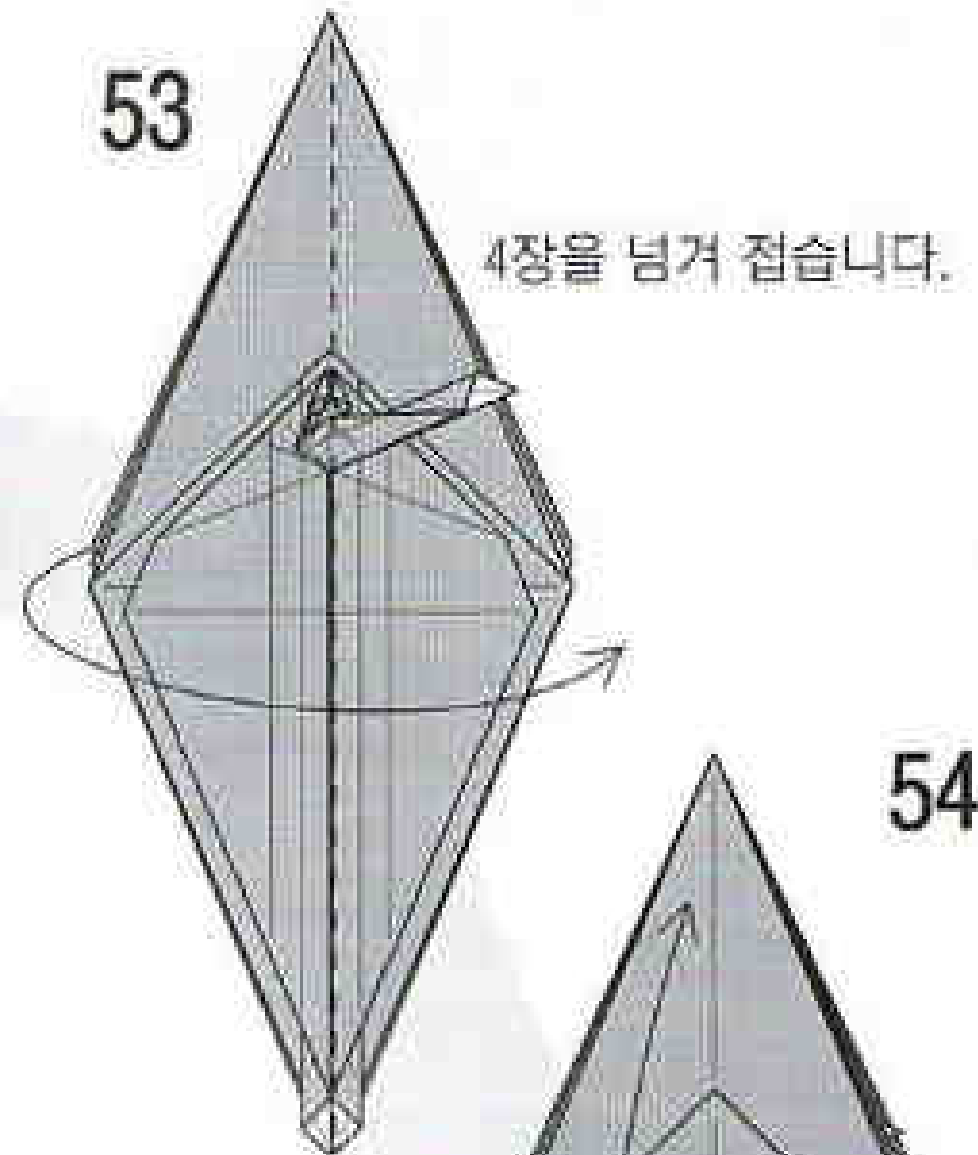
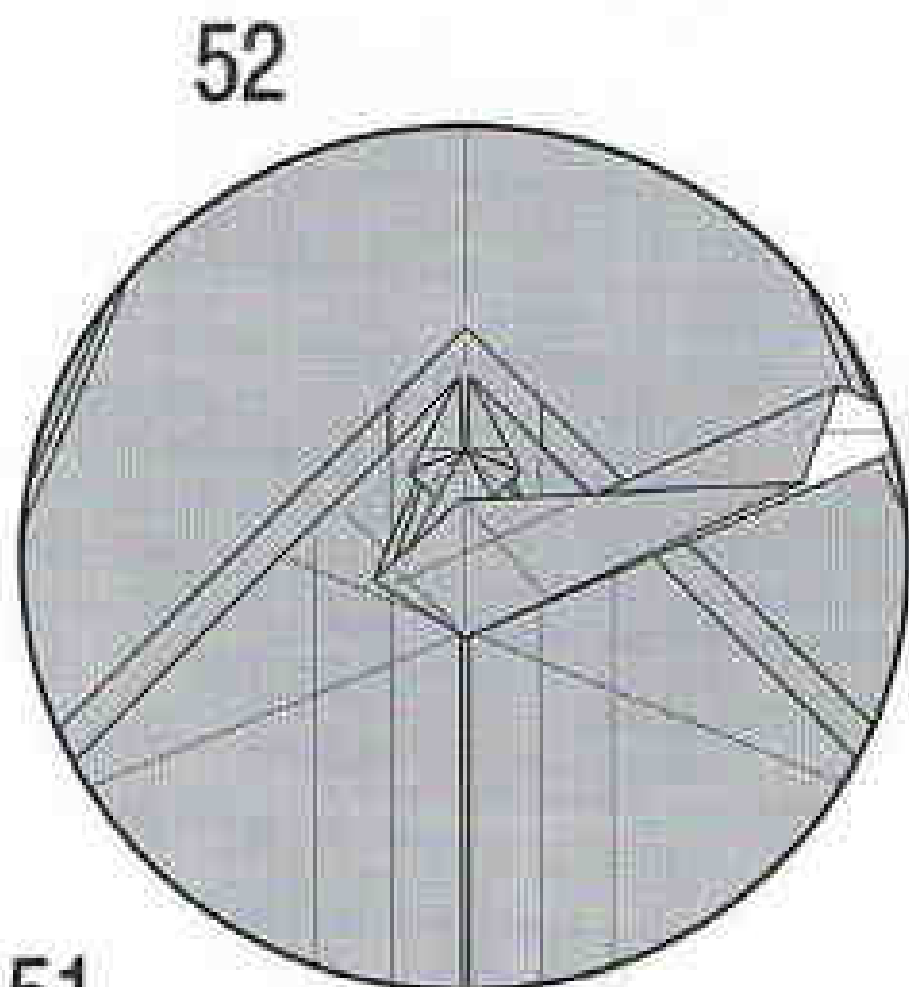
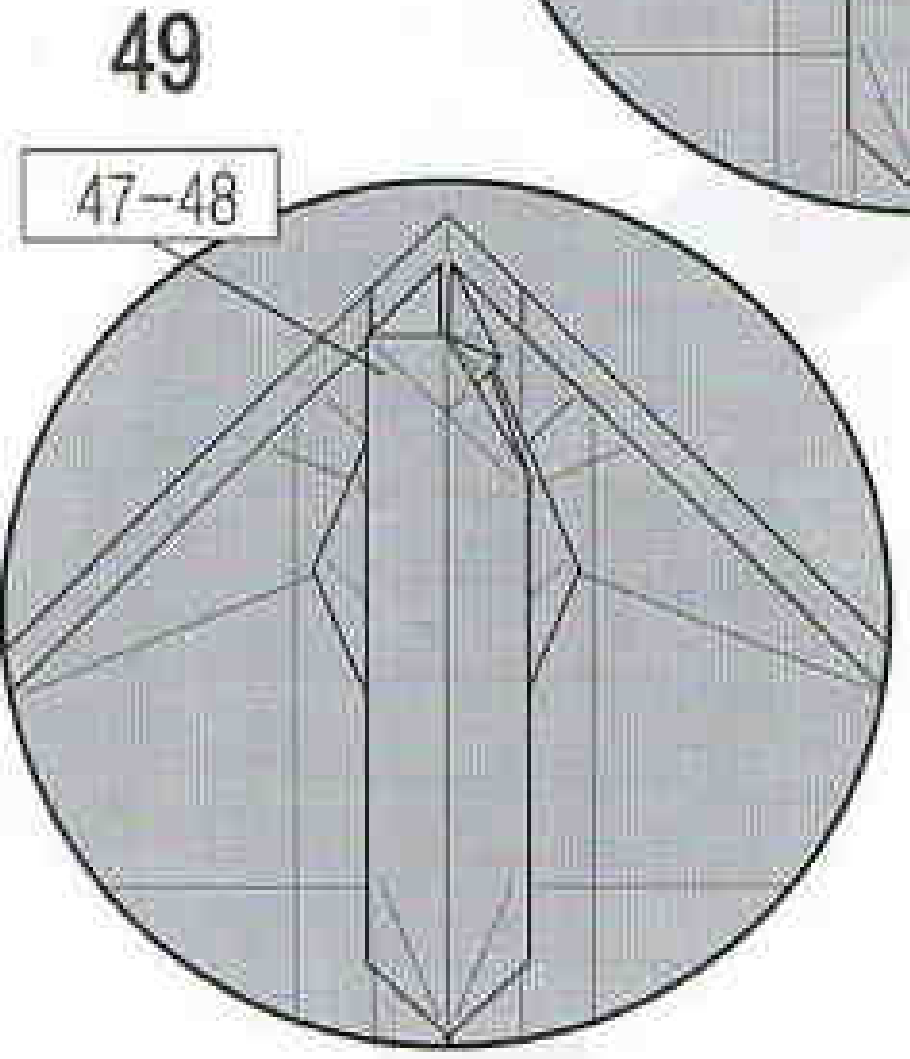
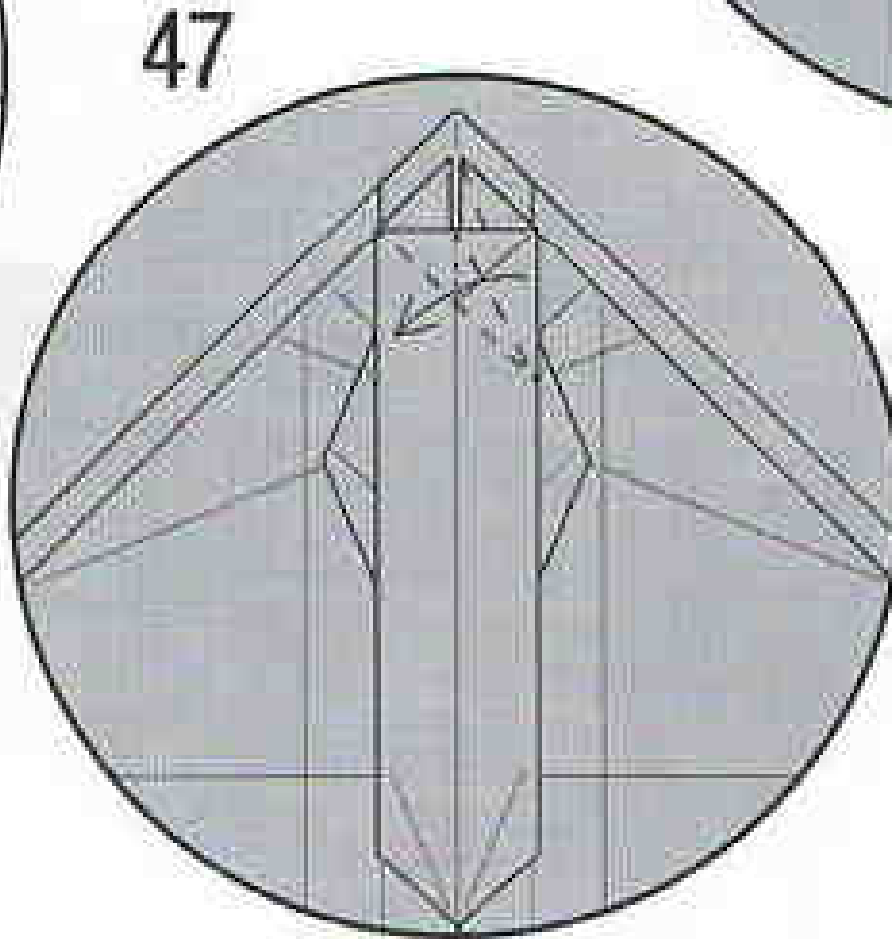
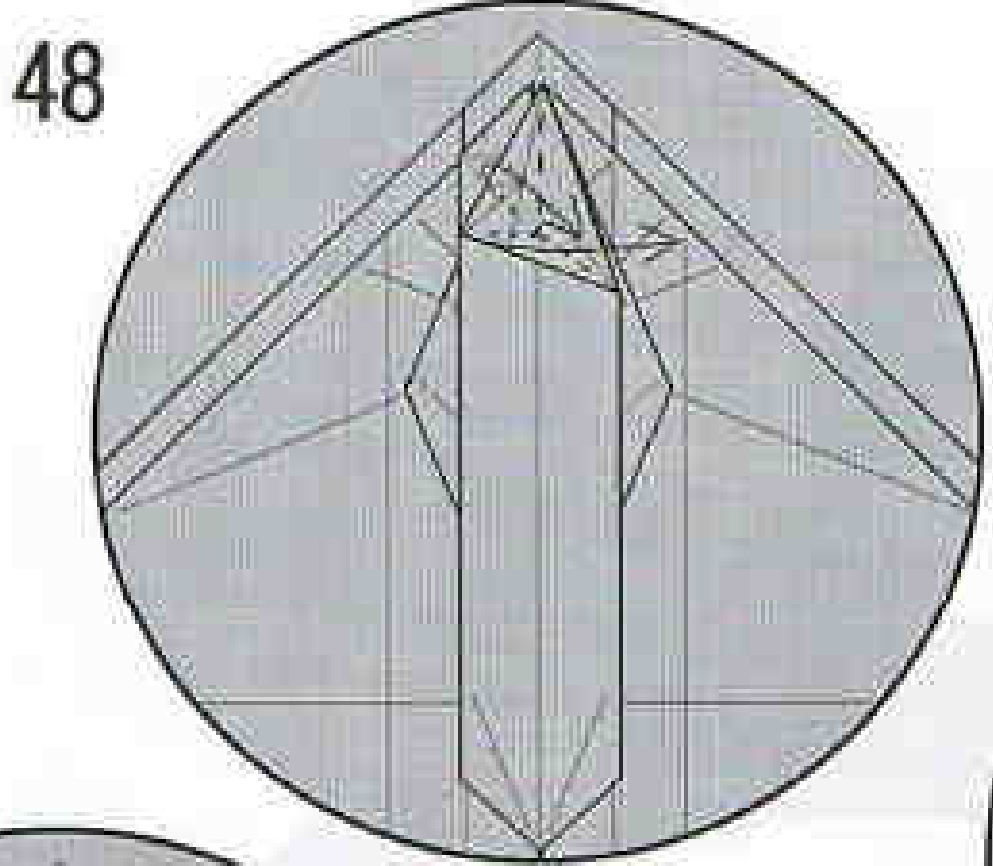
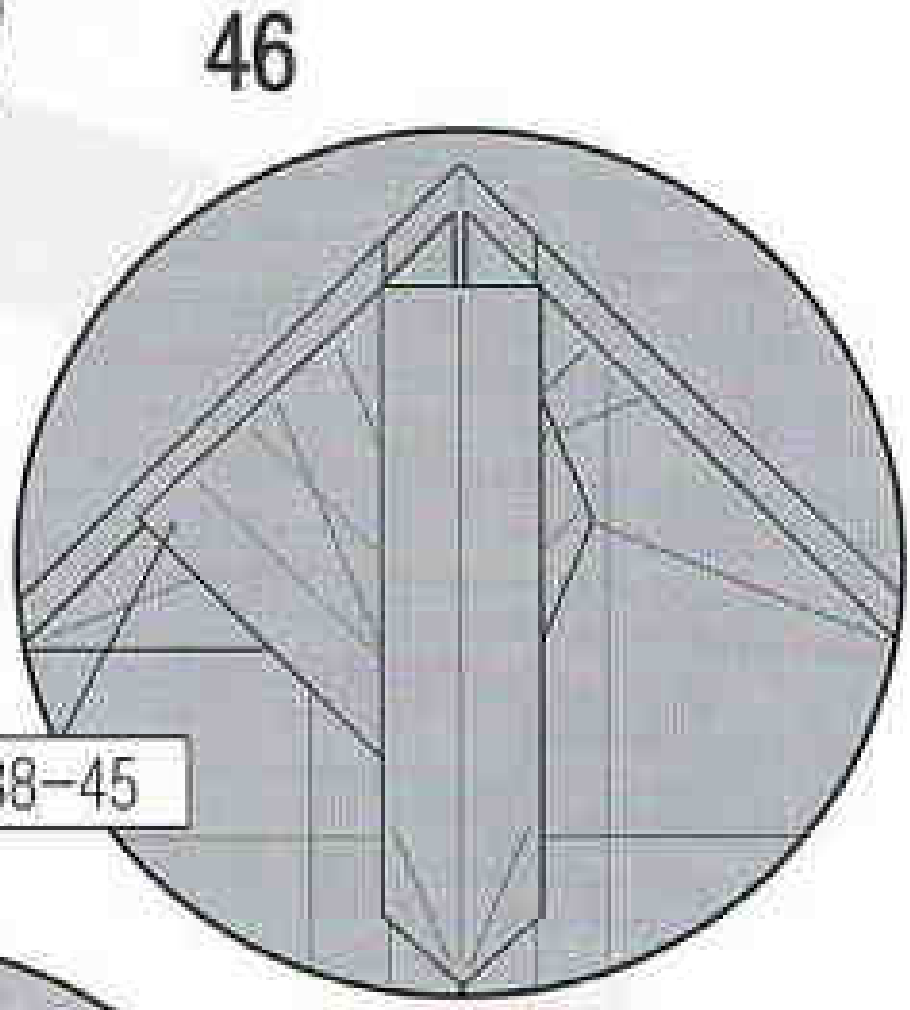
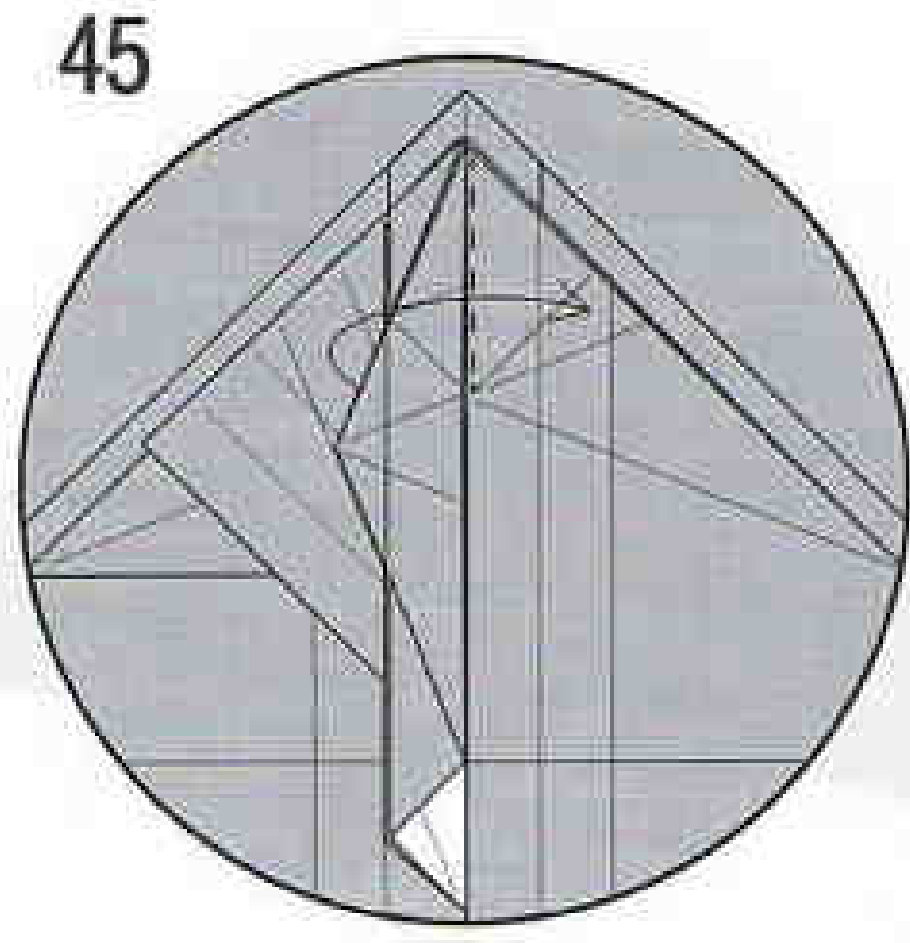
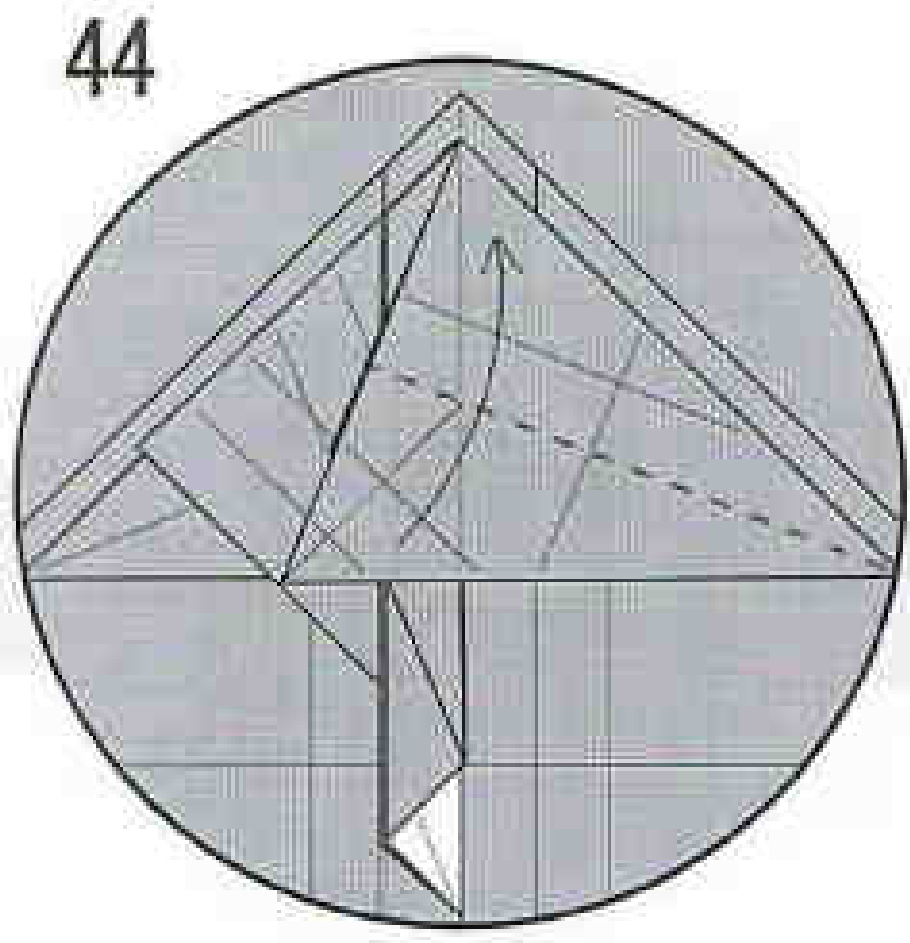

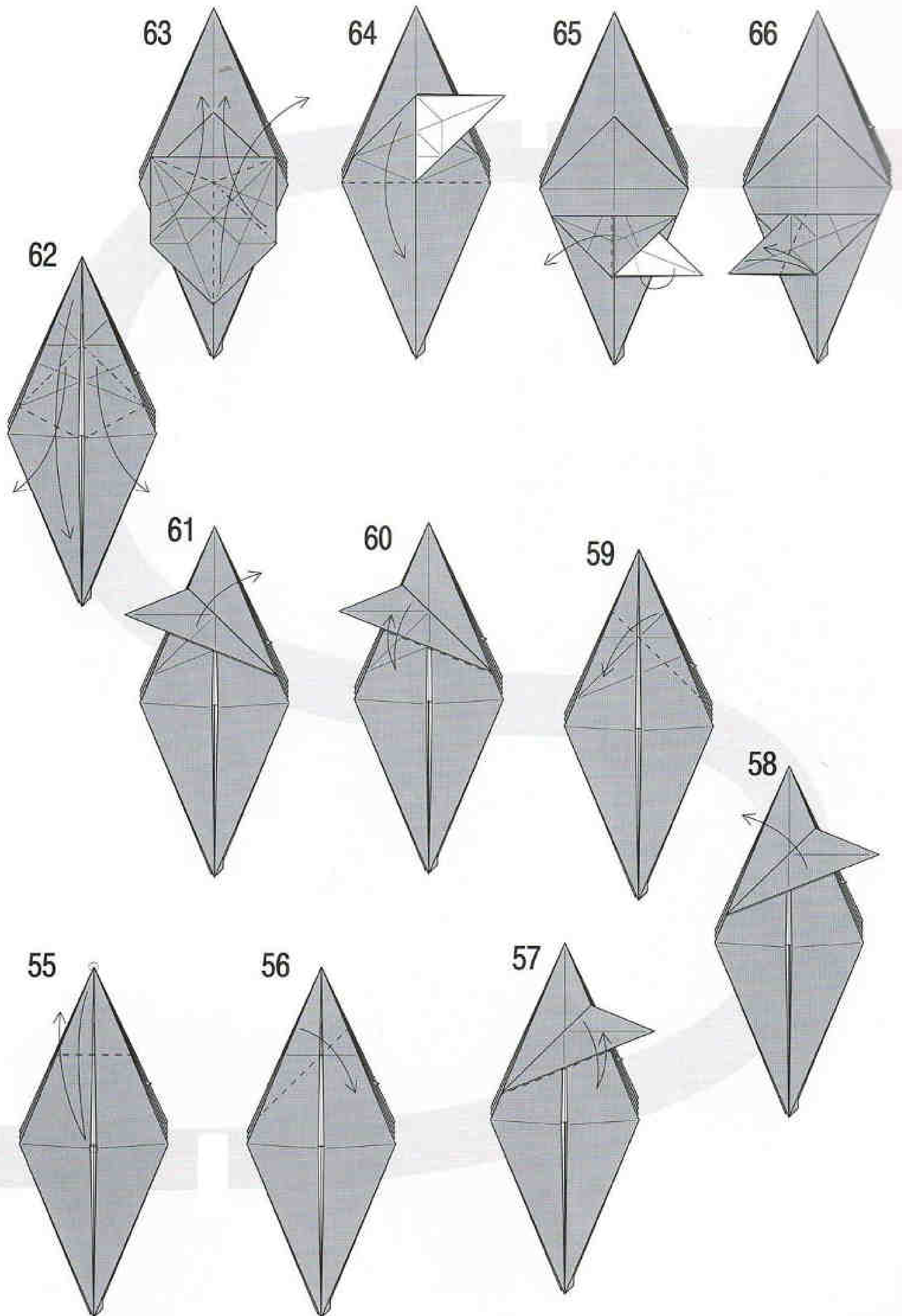

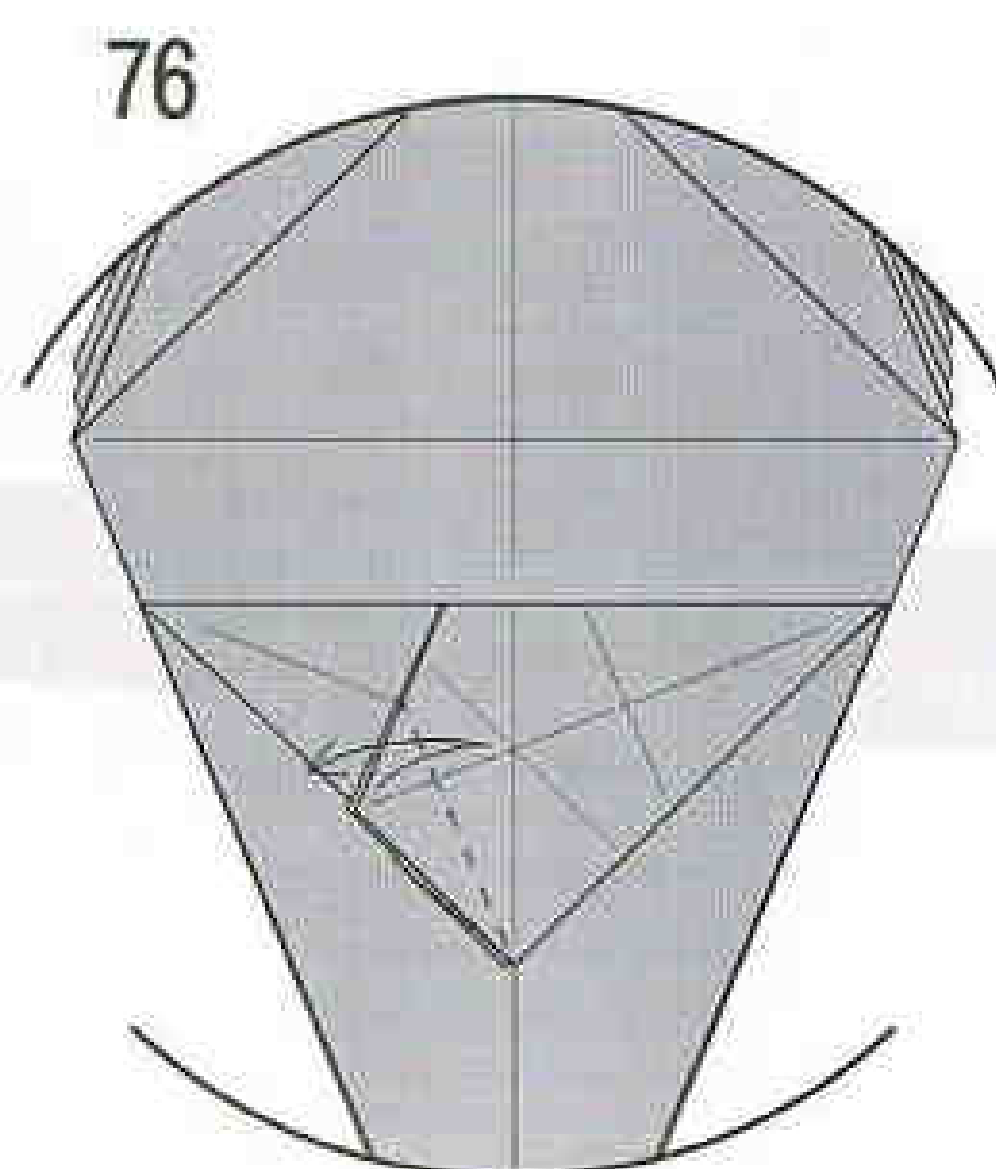
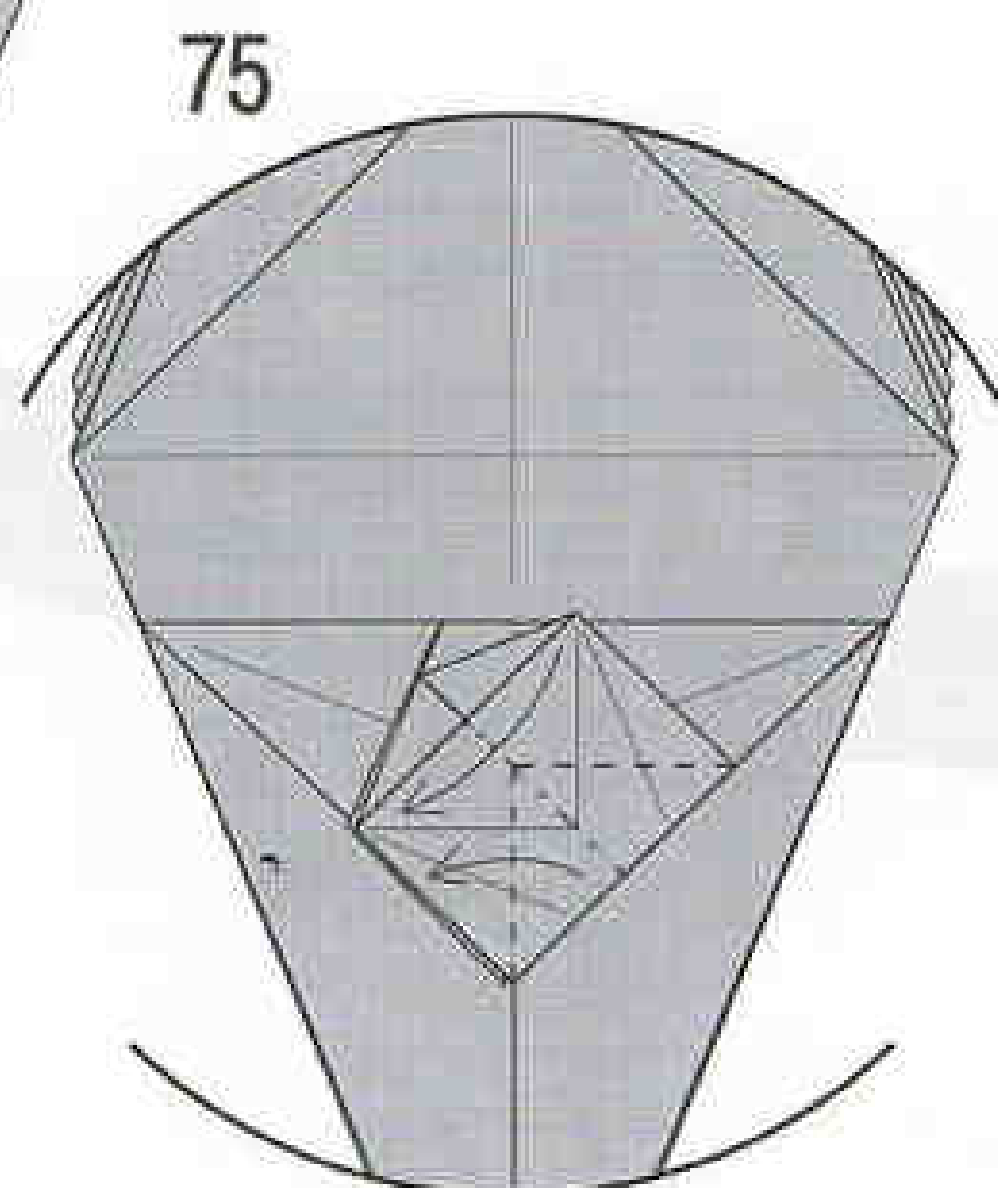
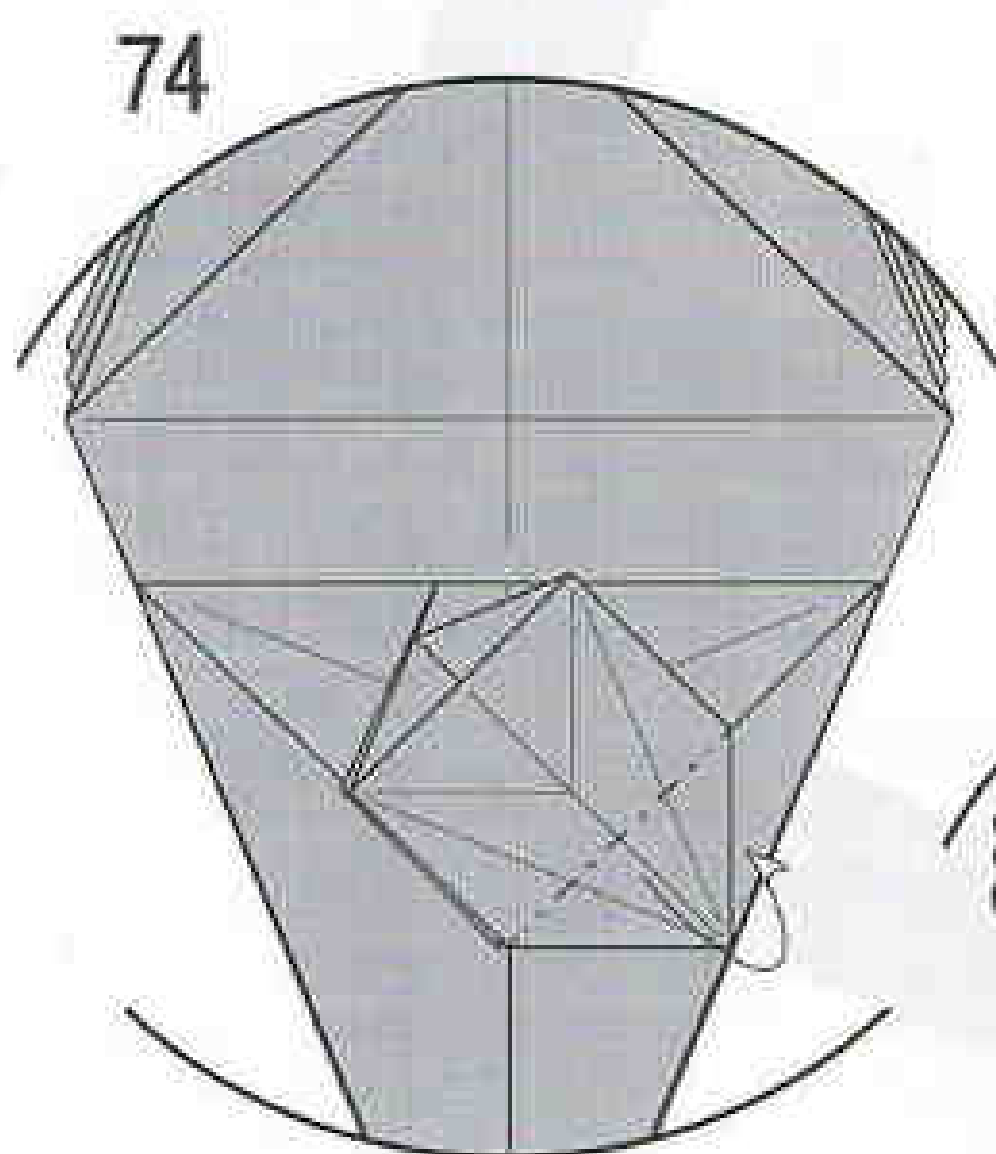
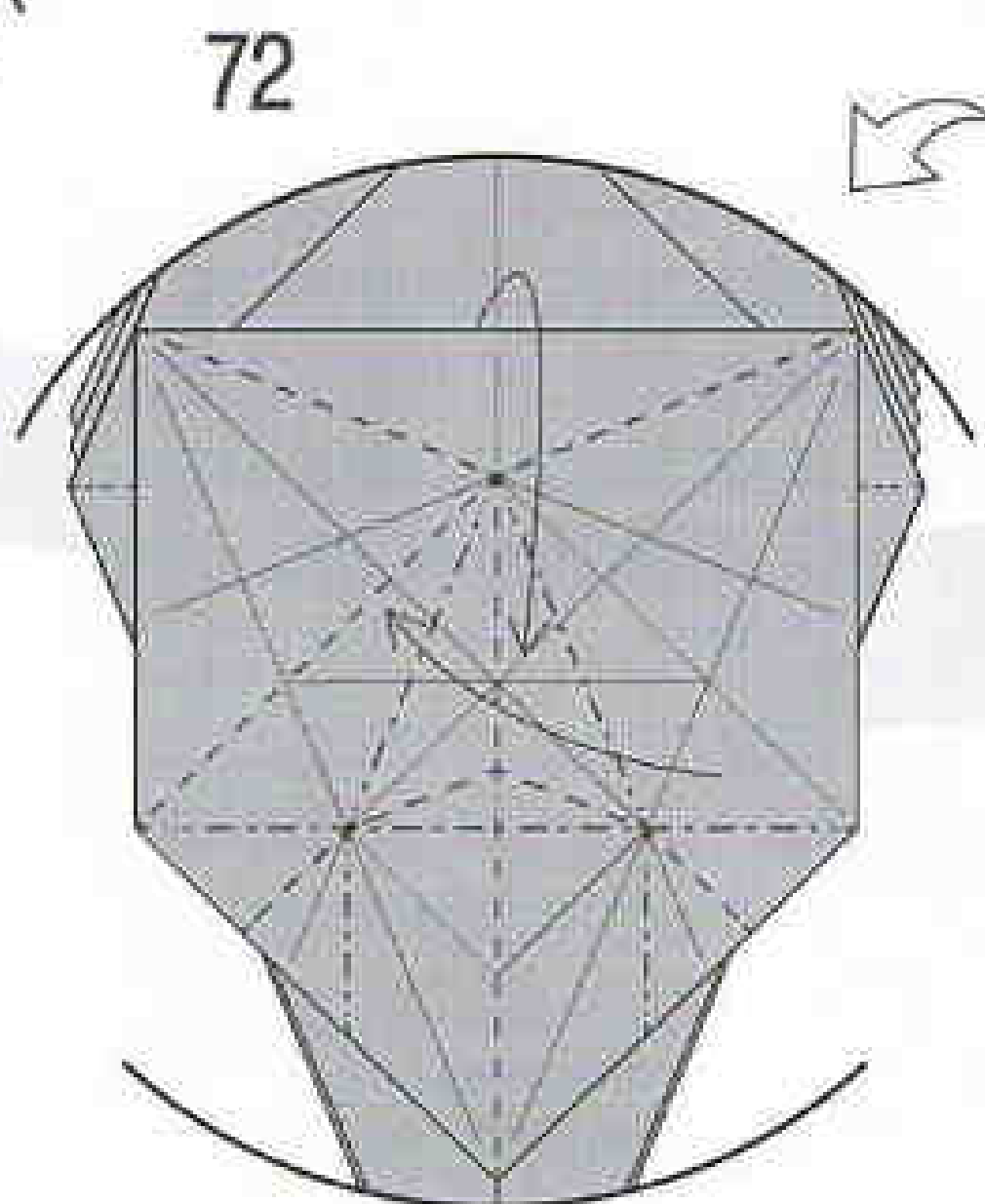
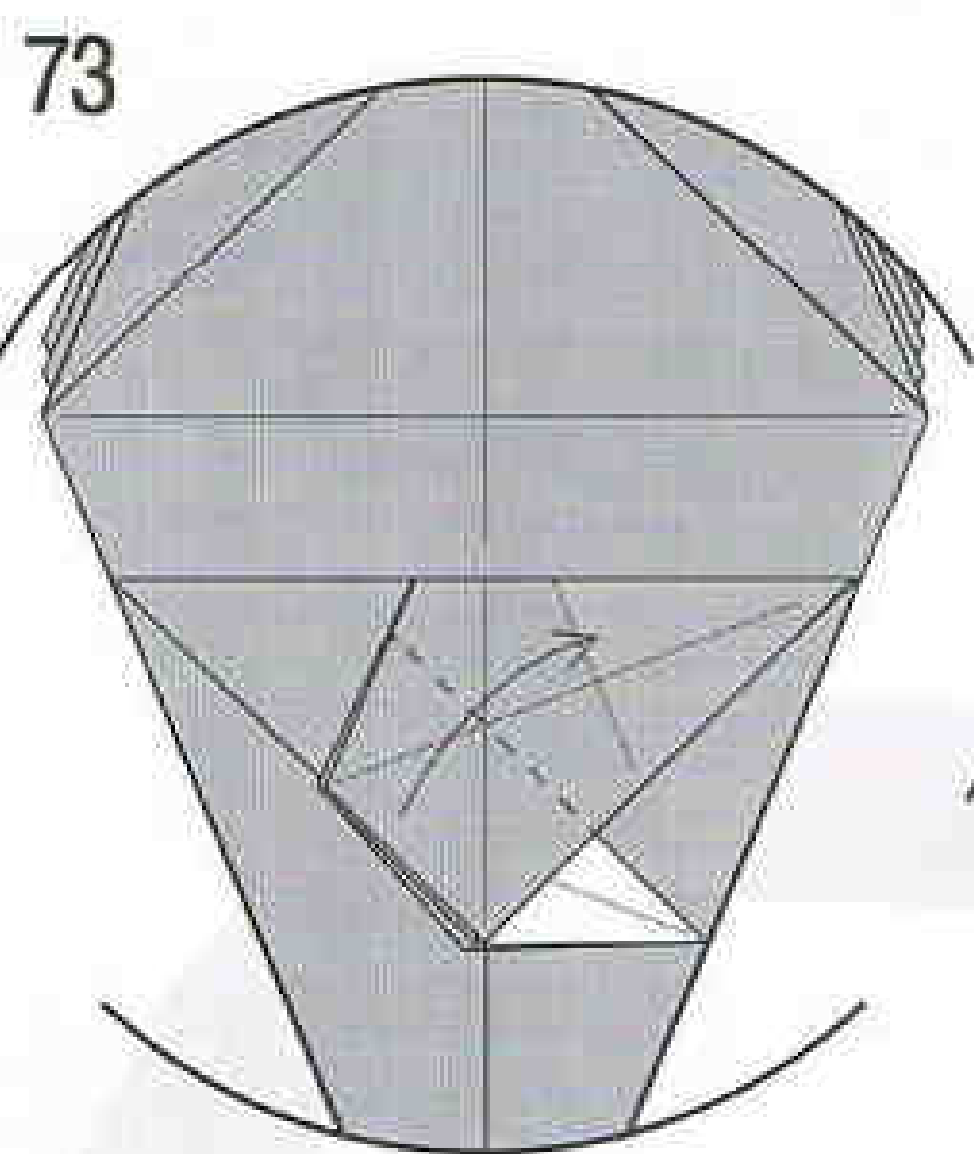
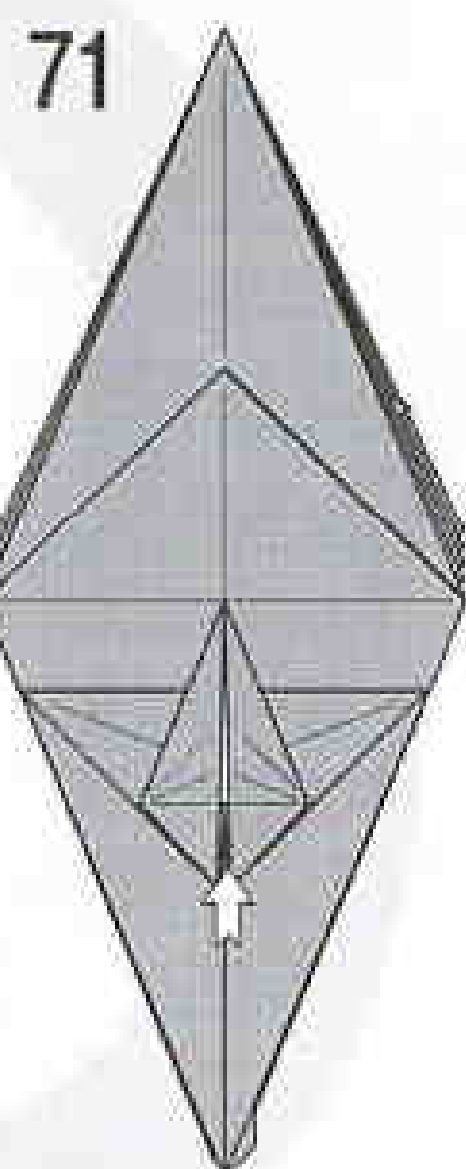
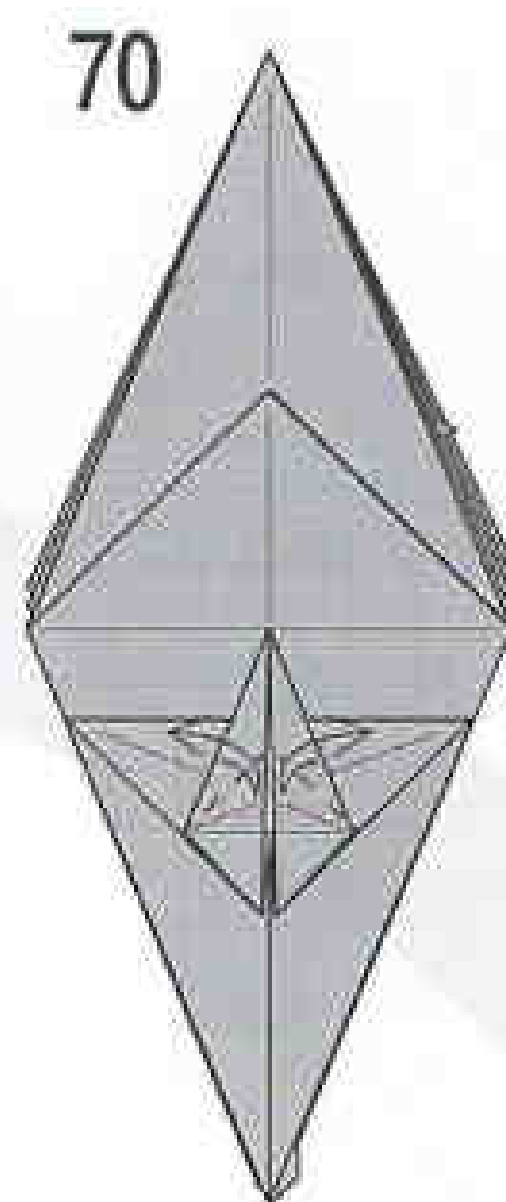
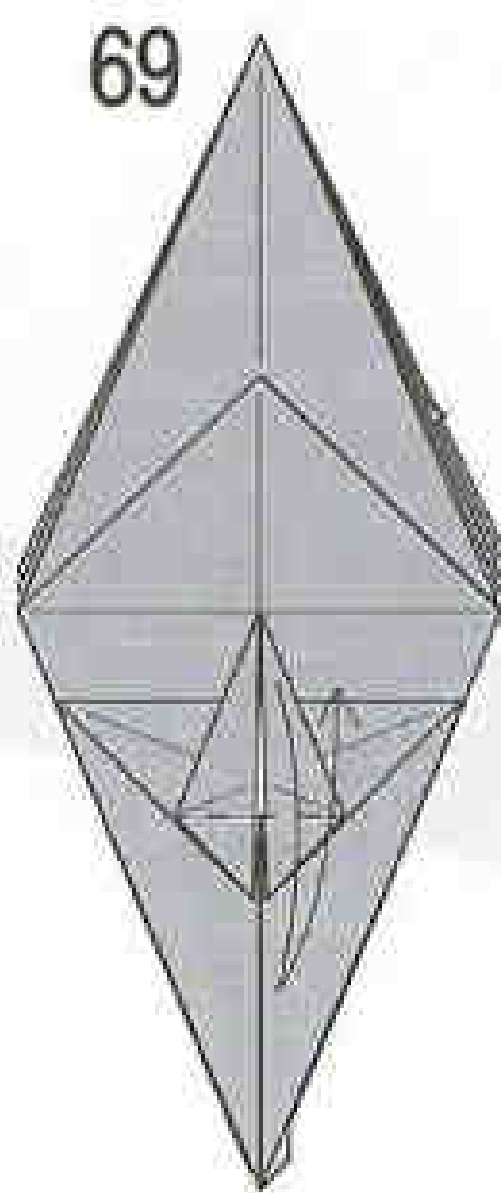
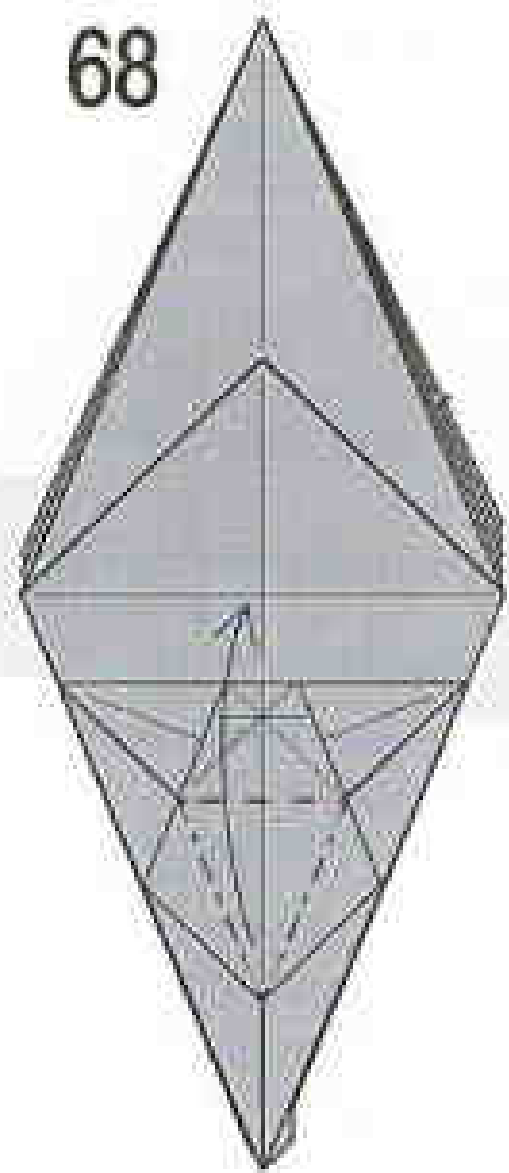
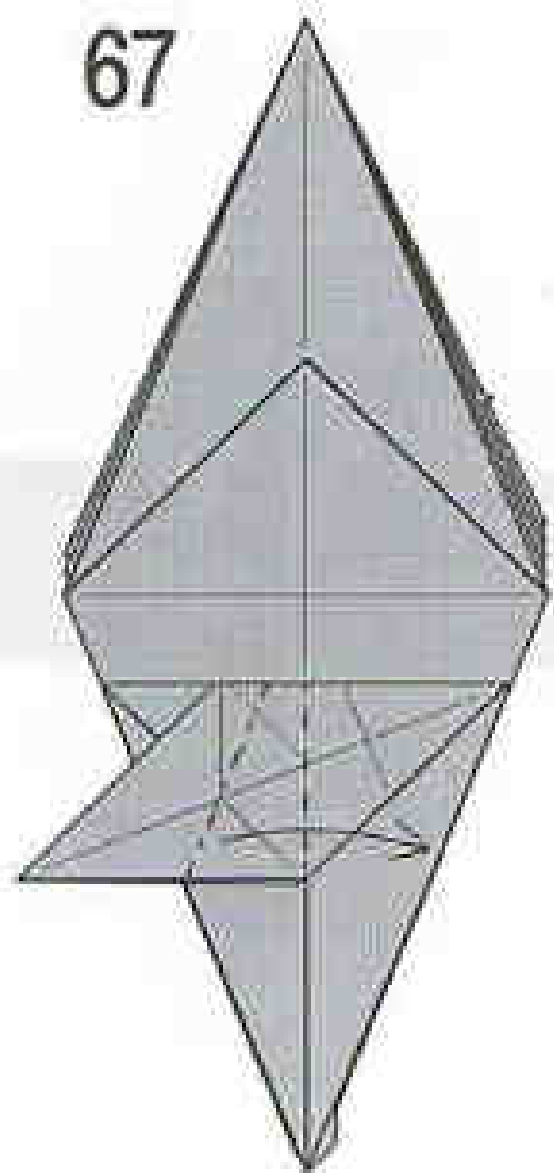

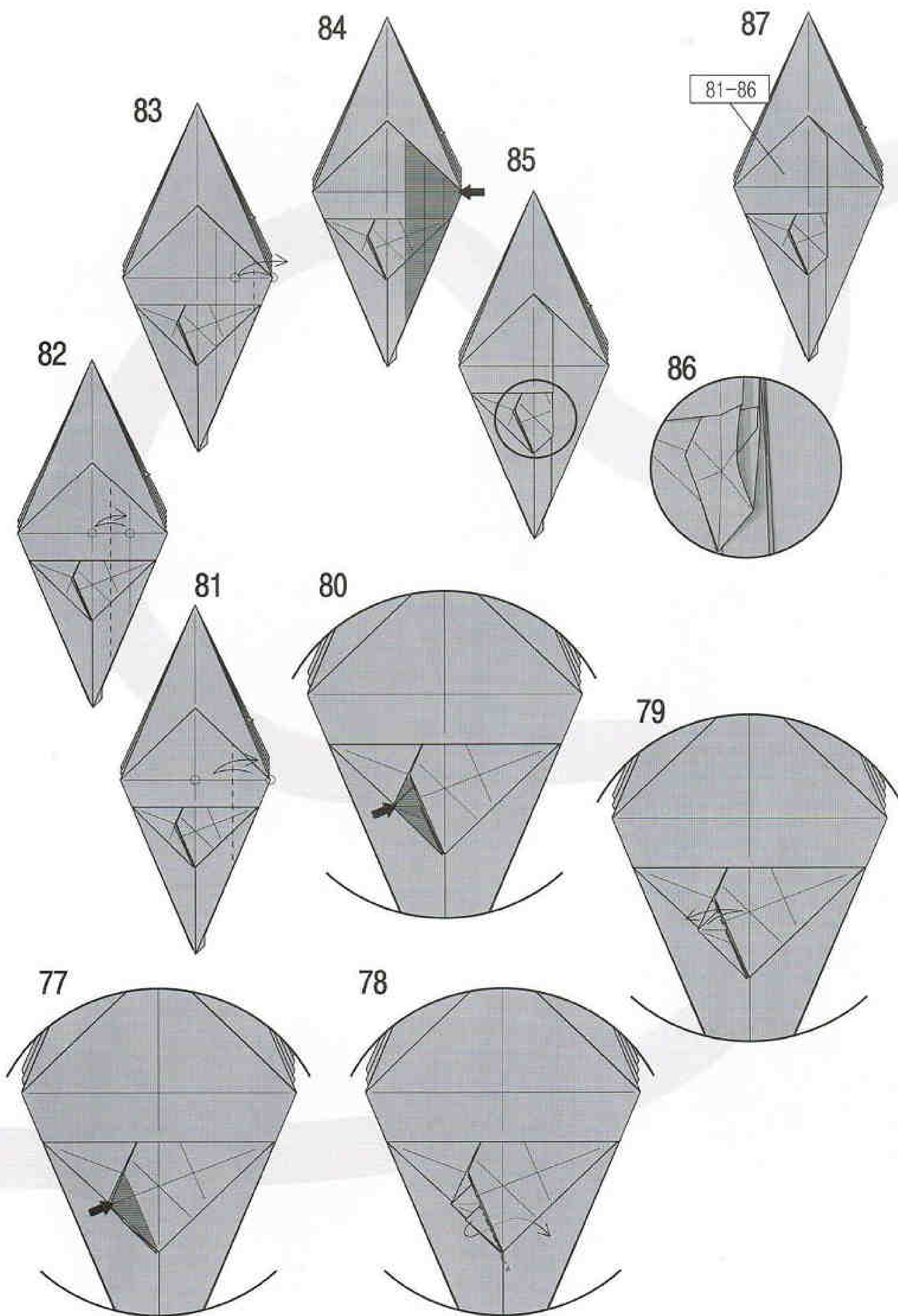

88

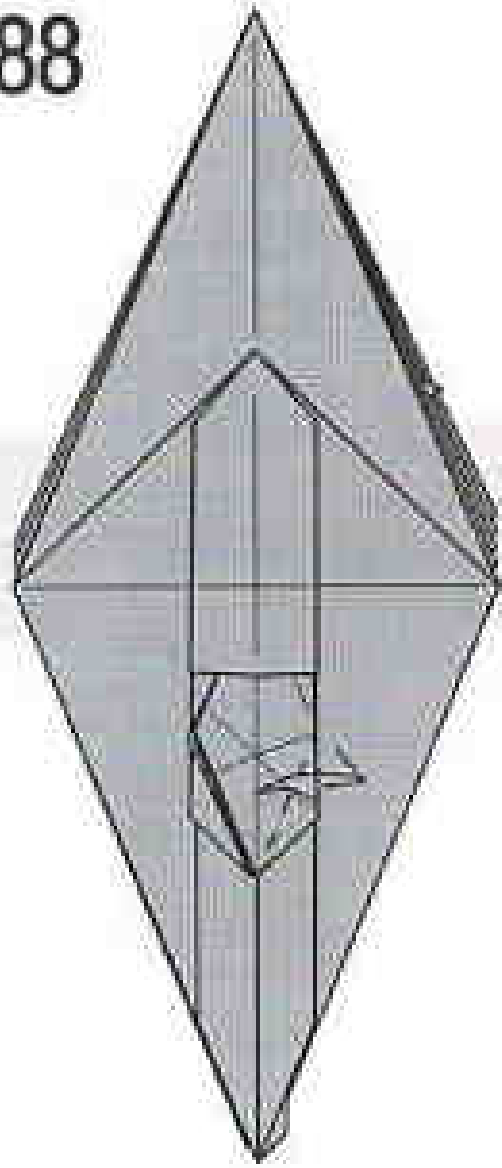

89

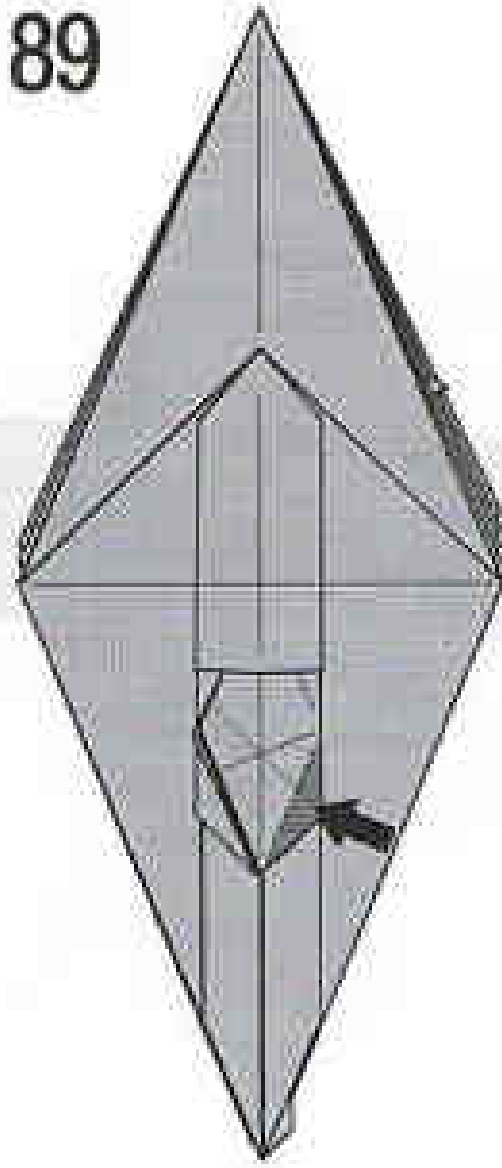

90

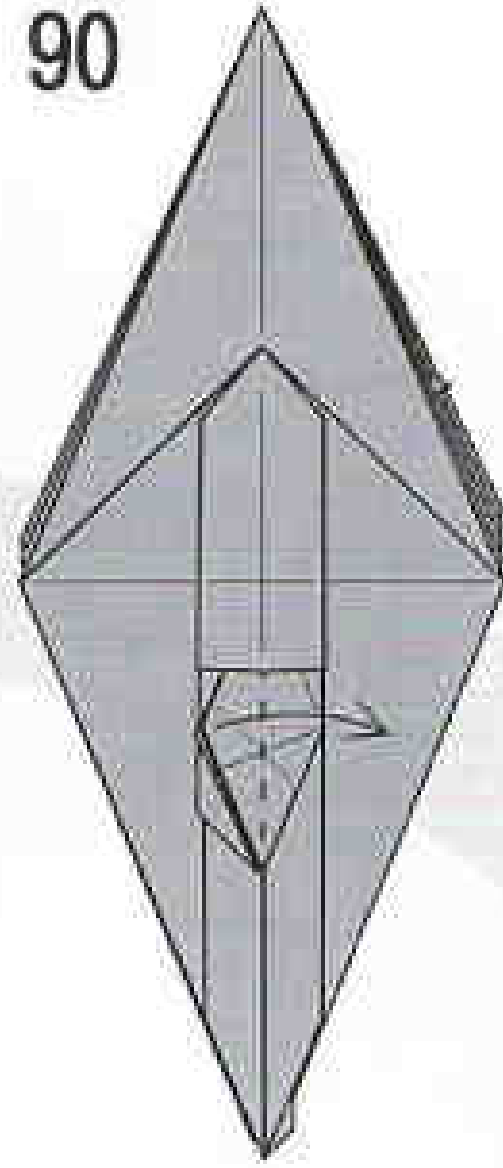

91

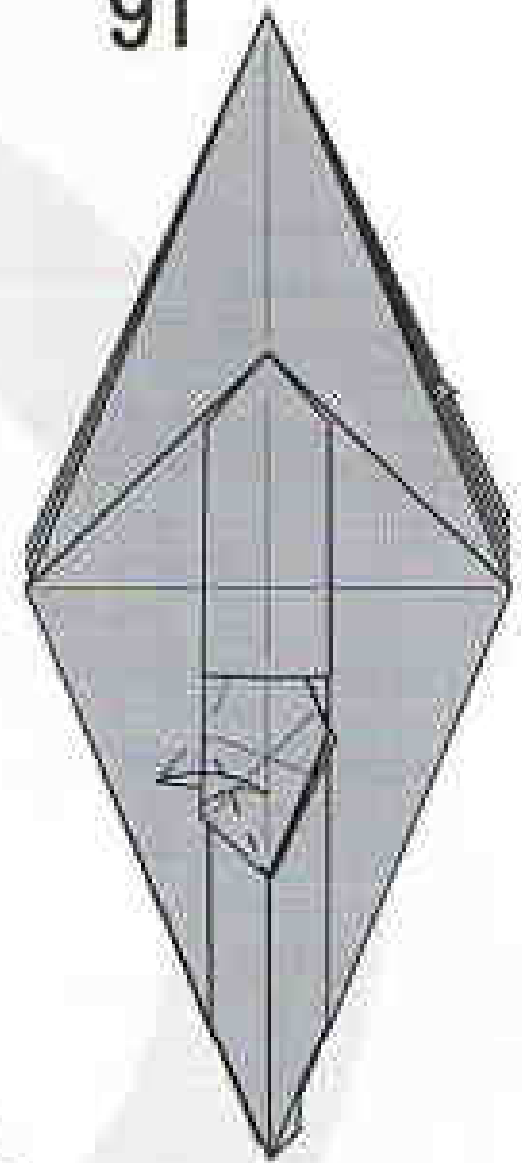

93

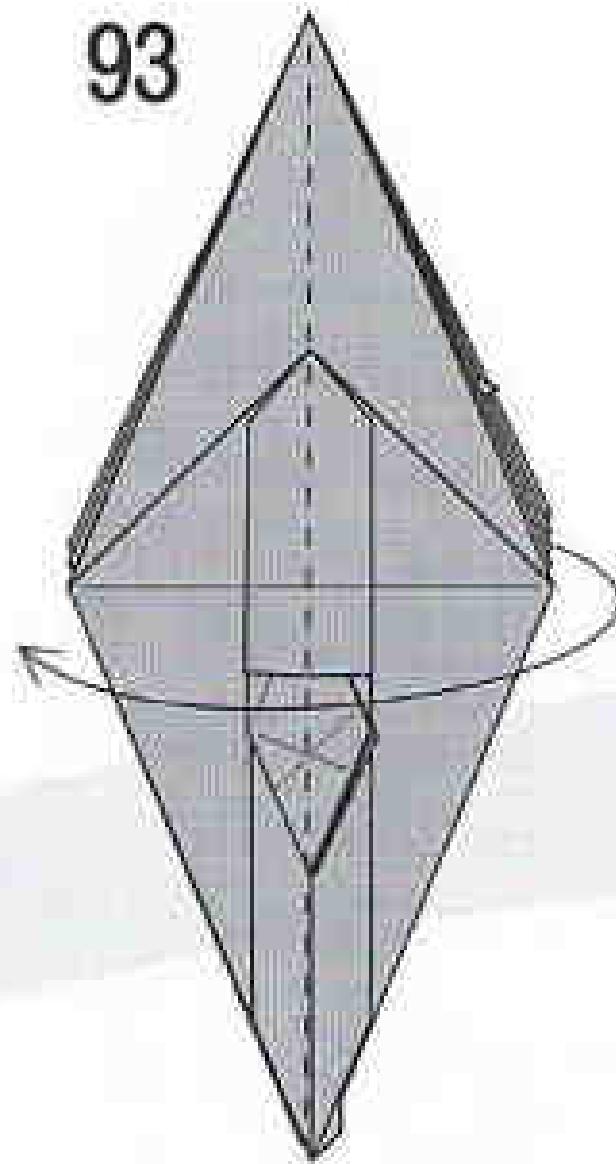

92

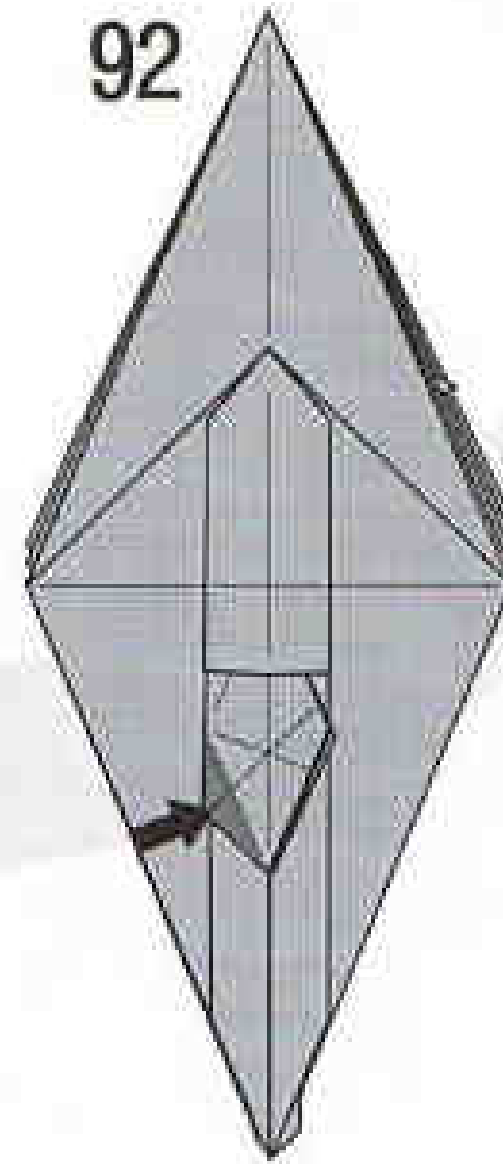

94

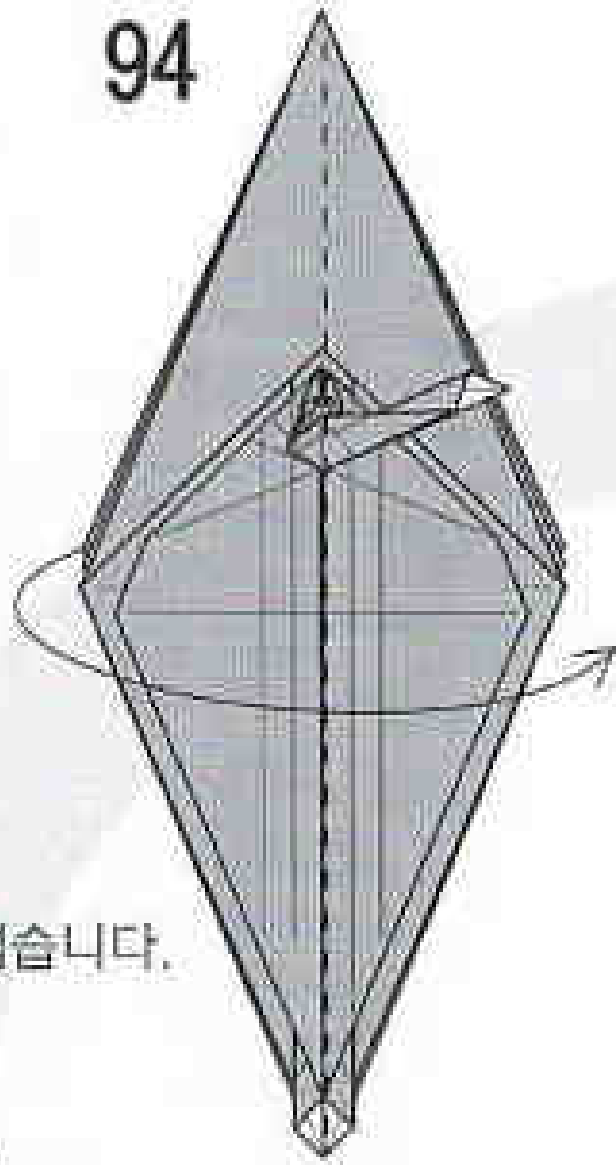

4장을 넘겨 접습니다.

4장을 넘겨 접습니다.

95

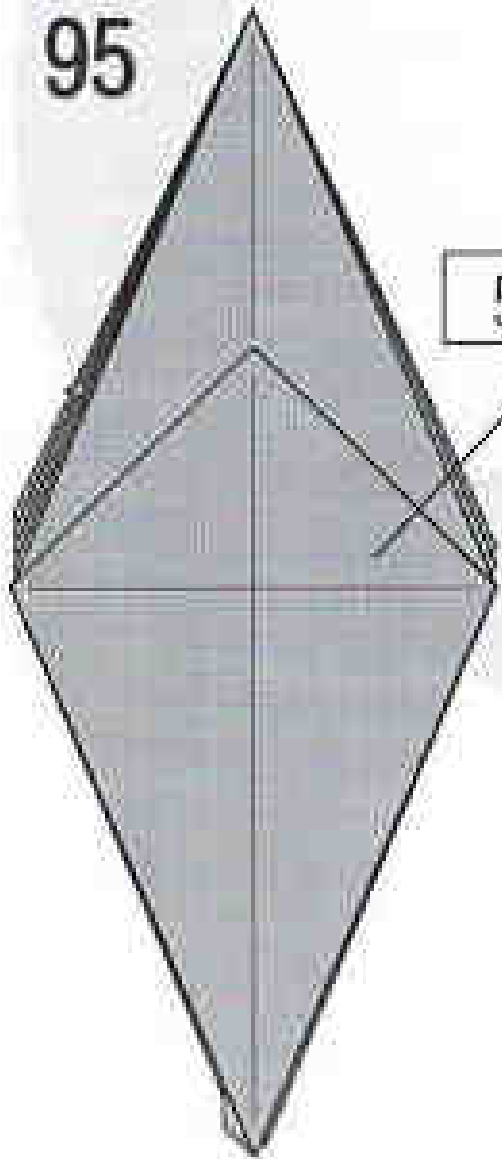

54-95

96

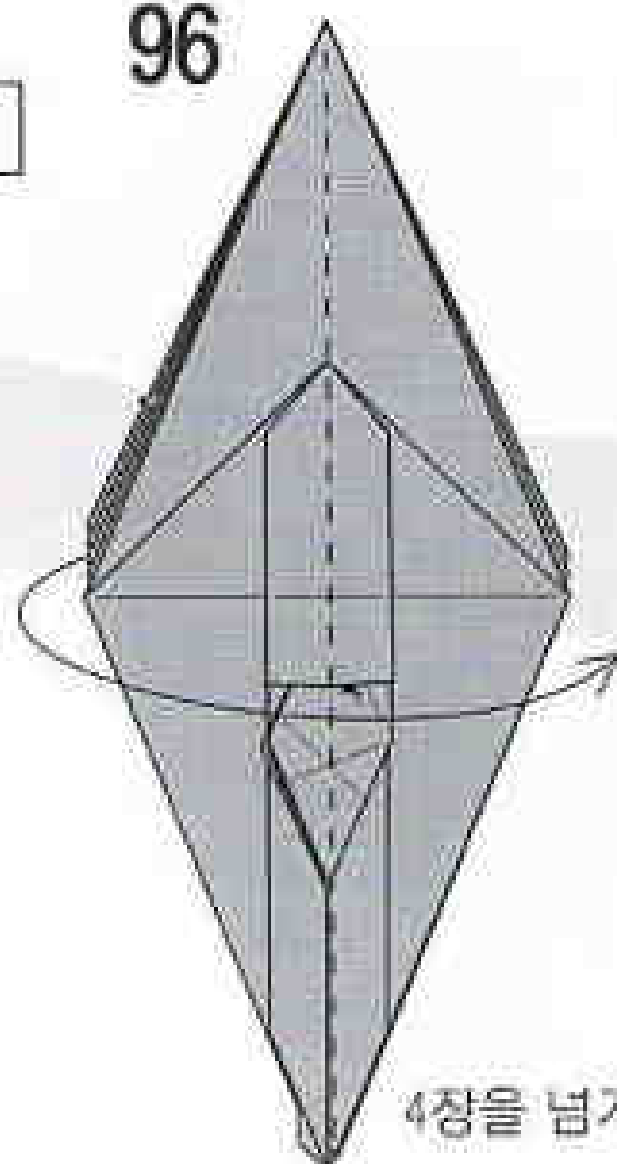

4장을 넘겨 접습니다.

97

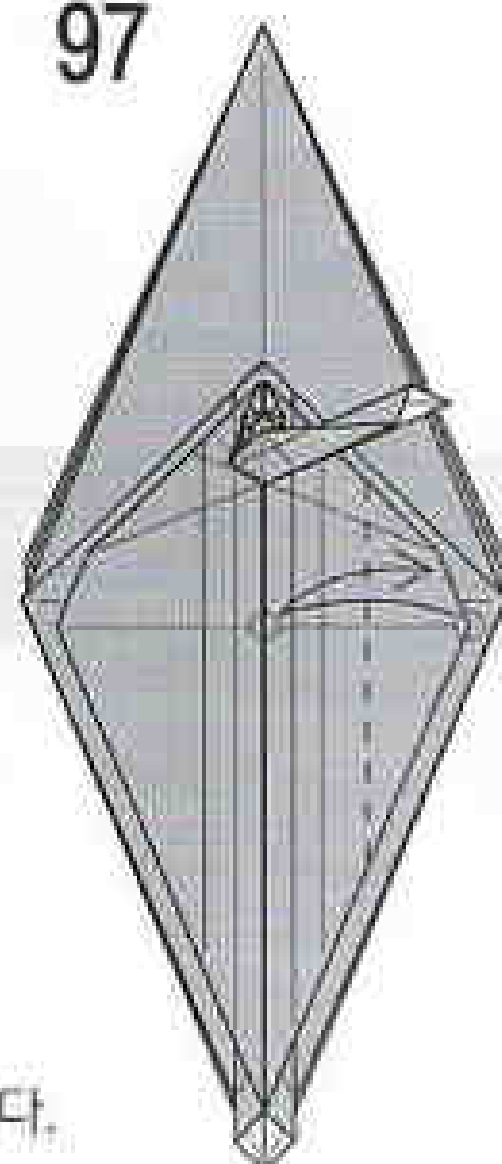

98

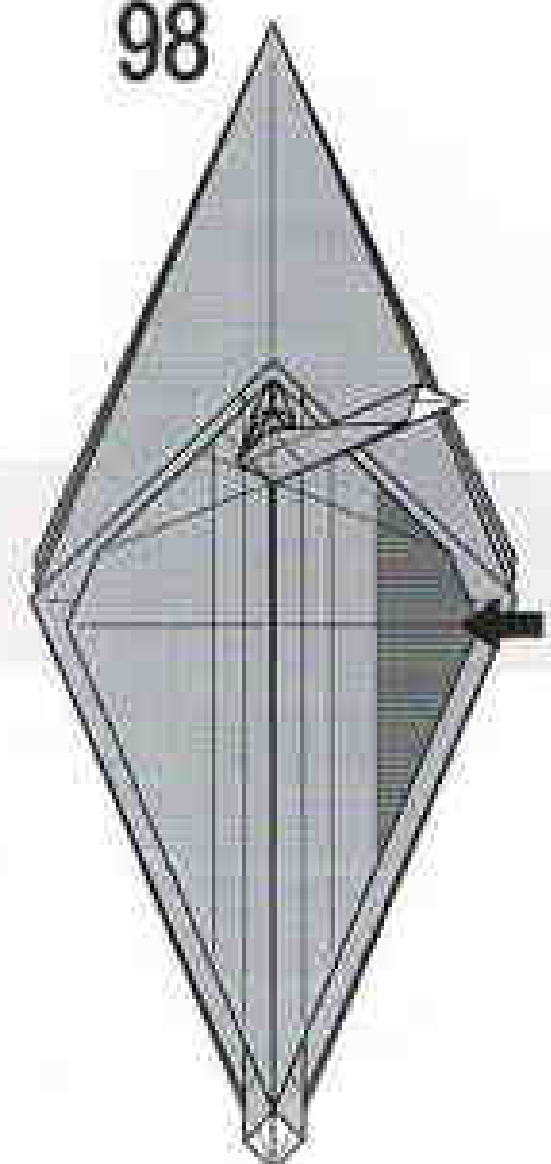

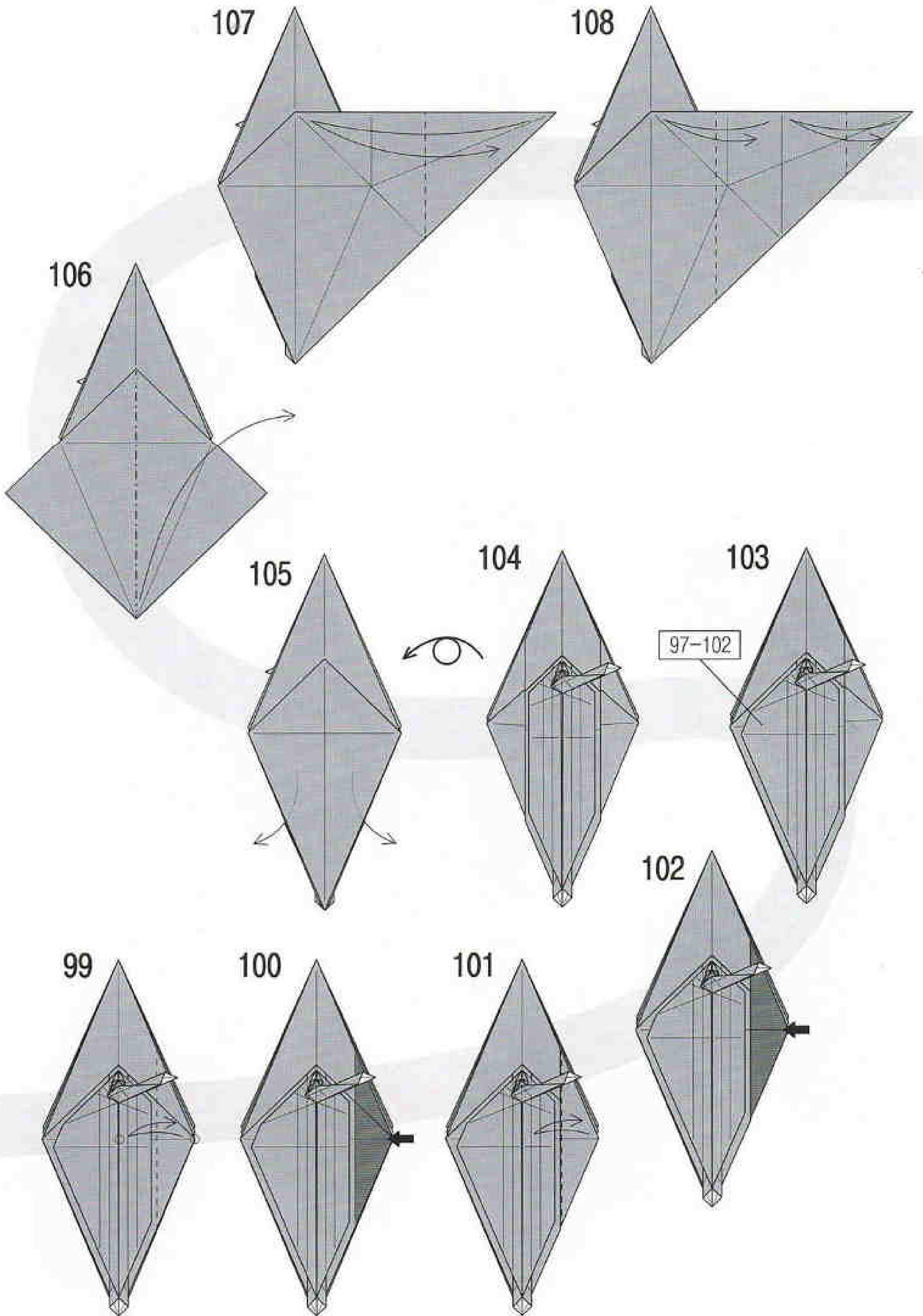

109

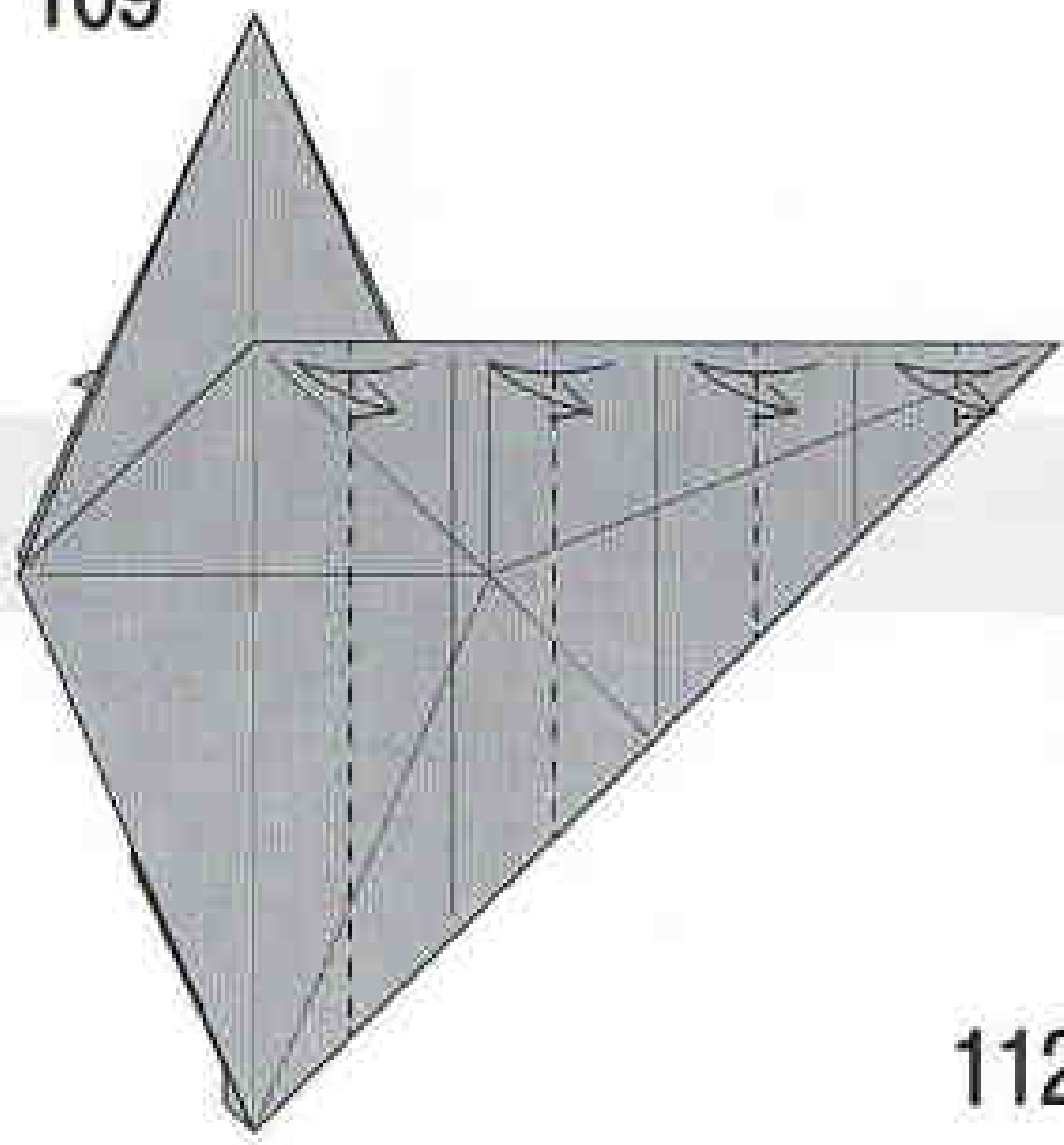

110

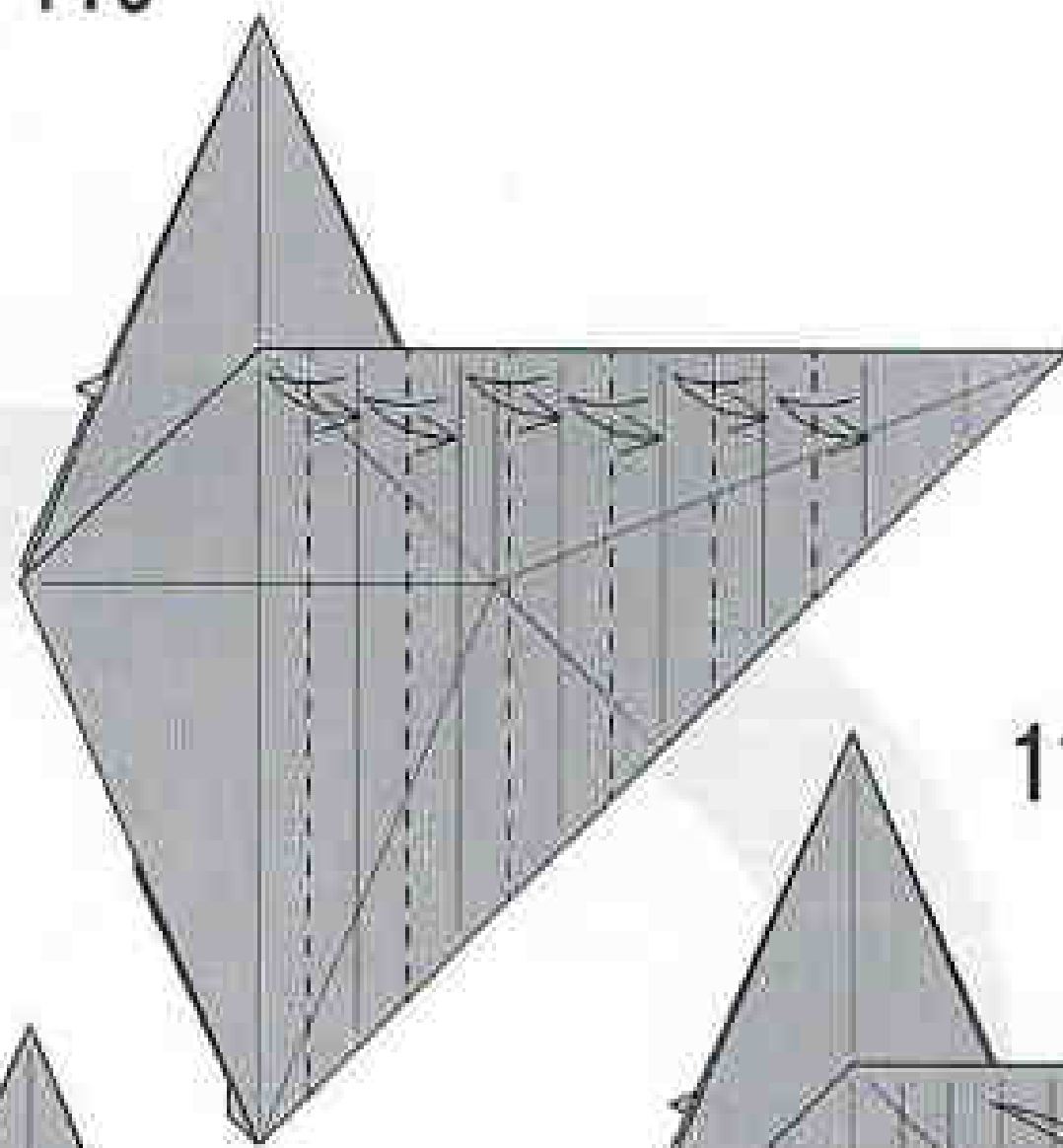

111

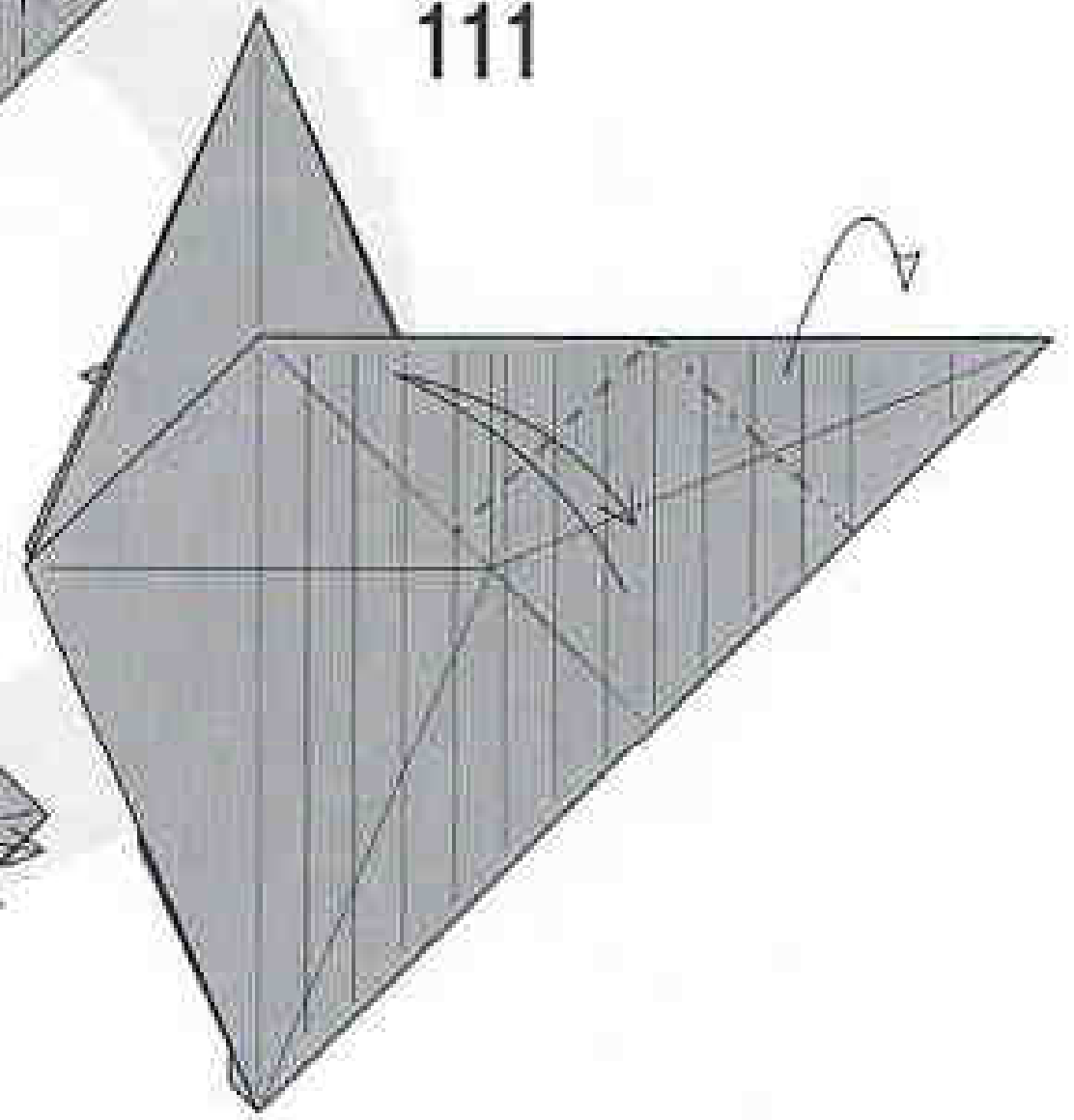

112

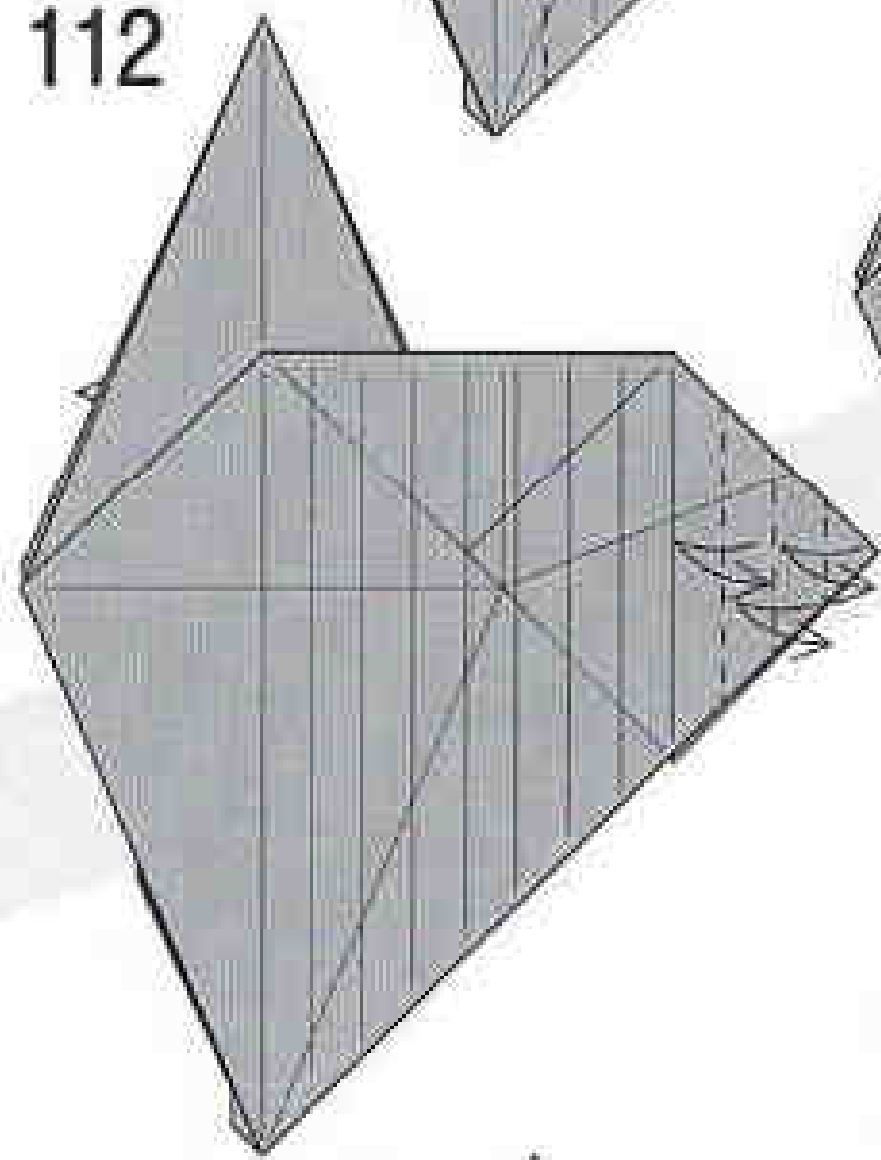

113

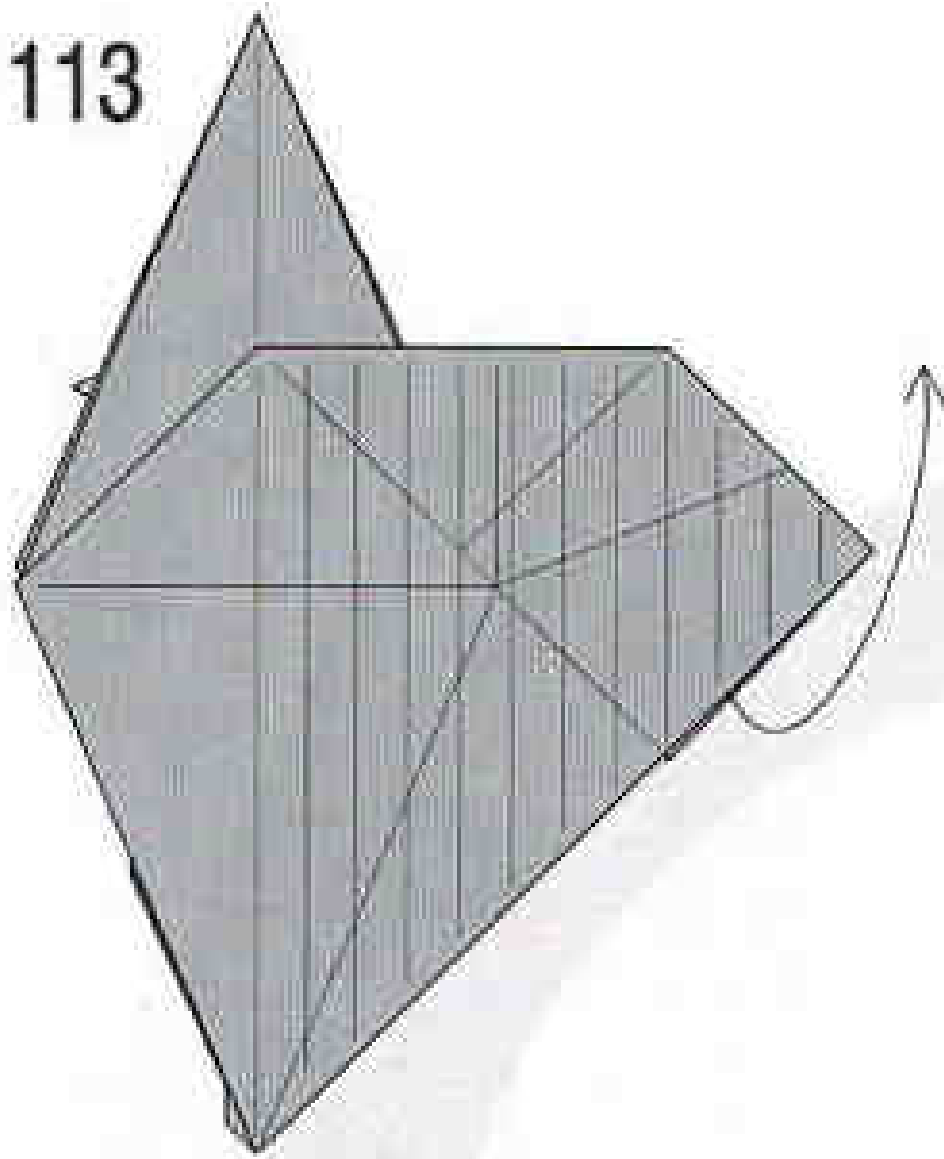

117

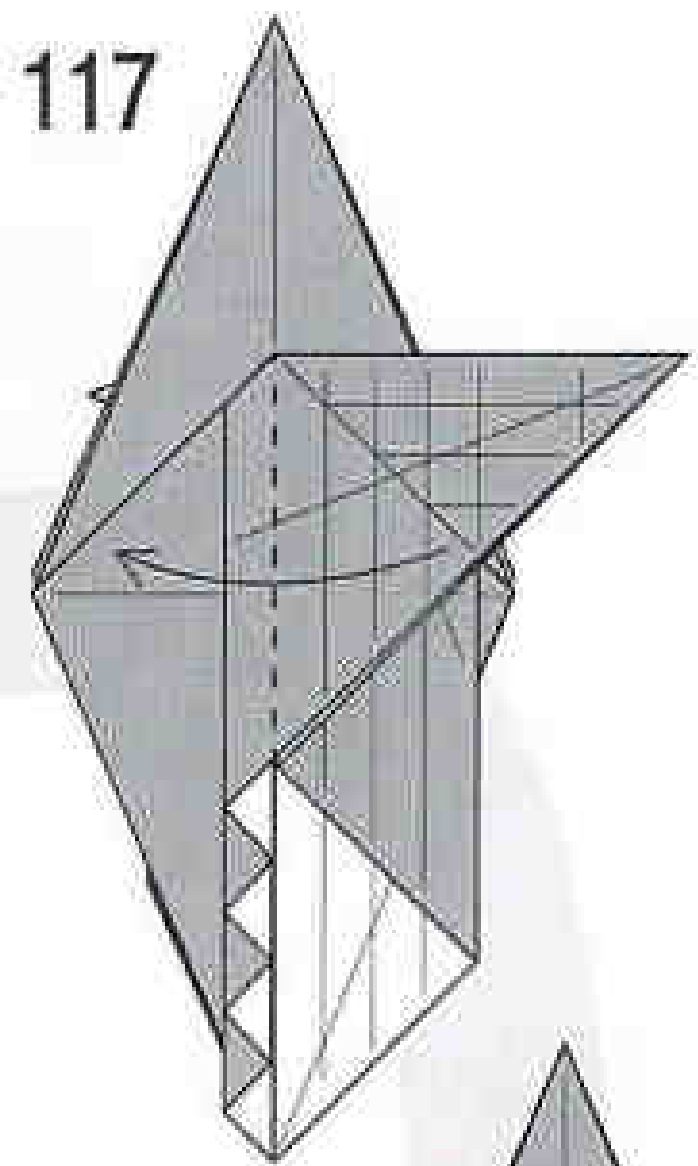

116

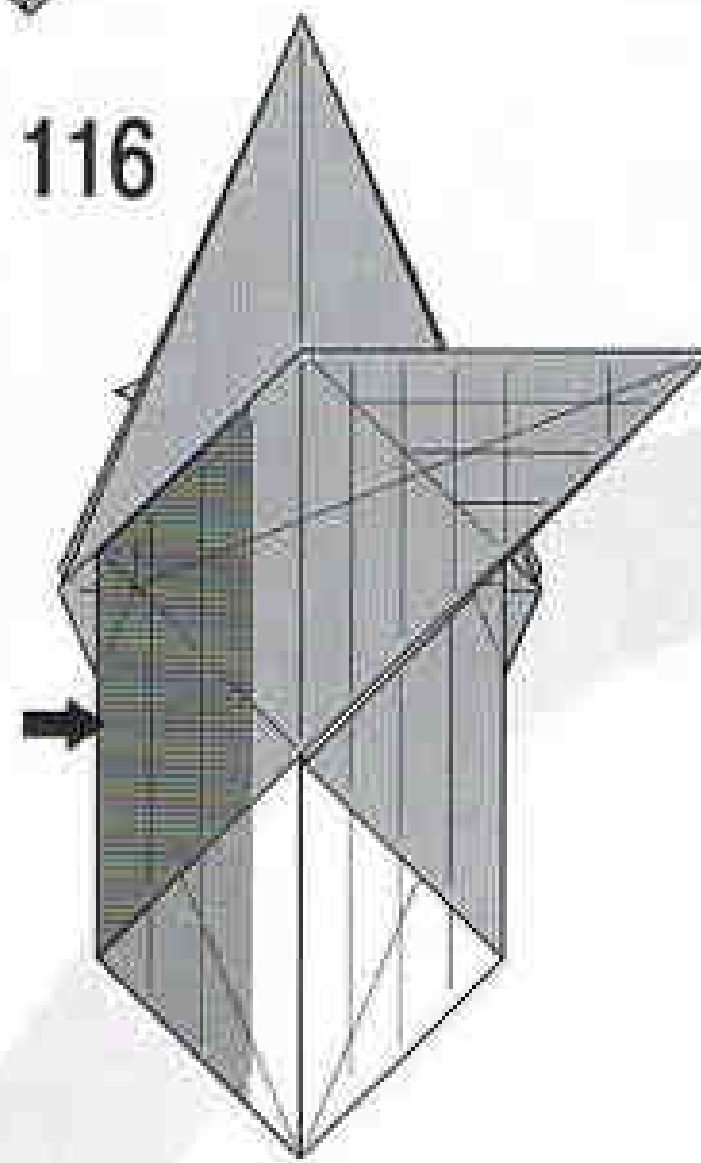

114

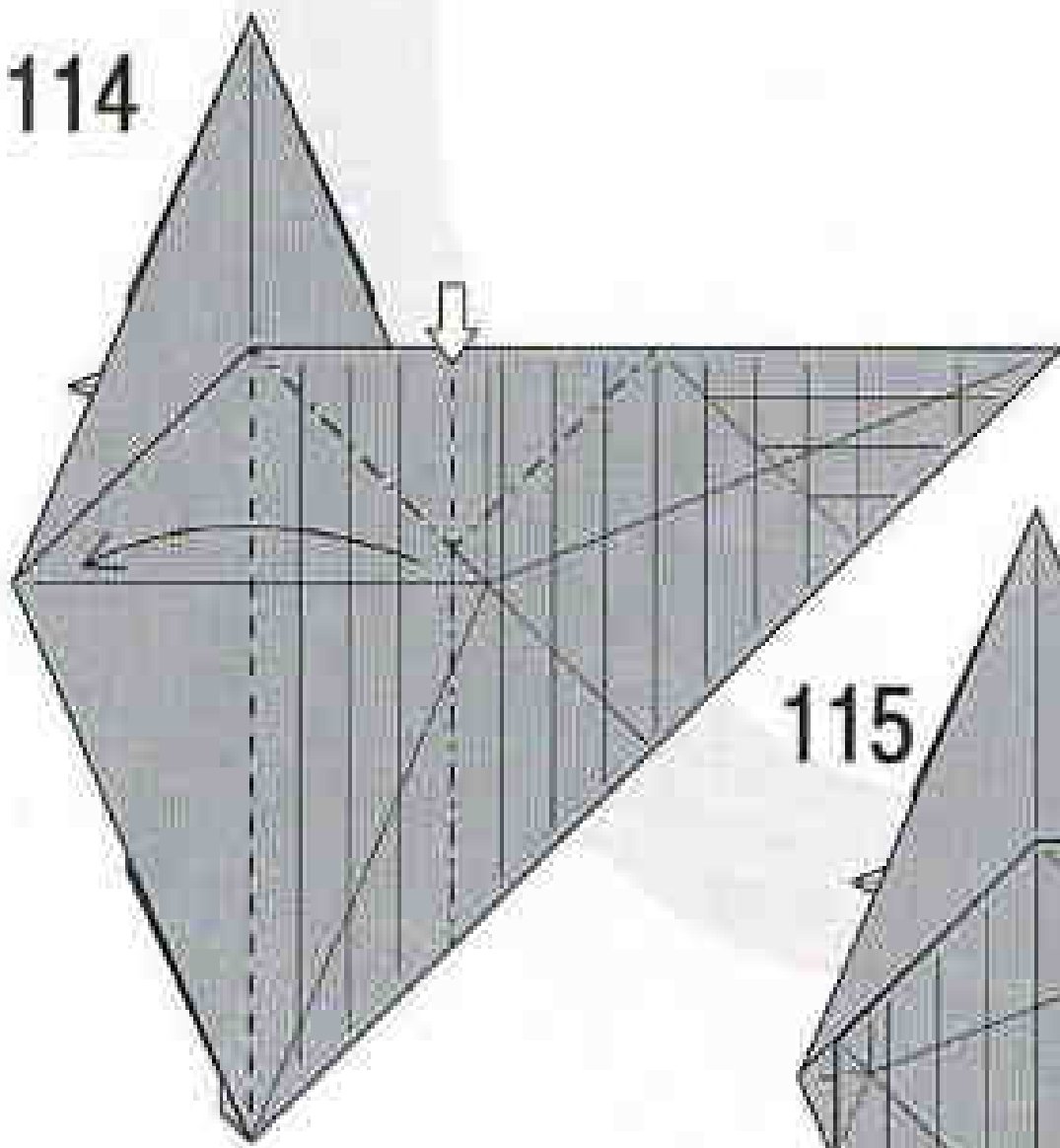

118

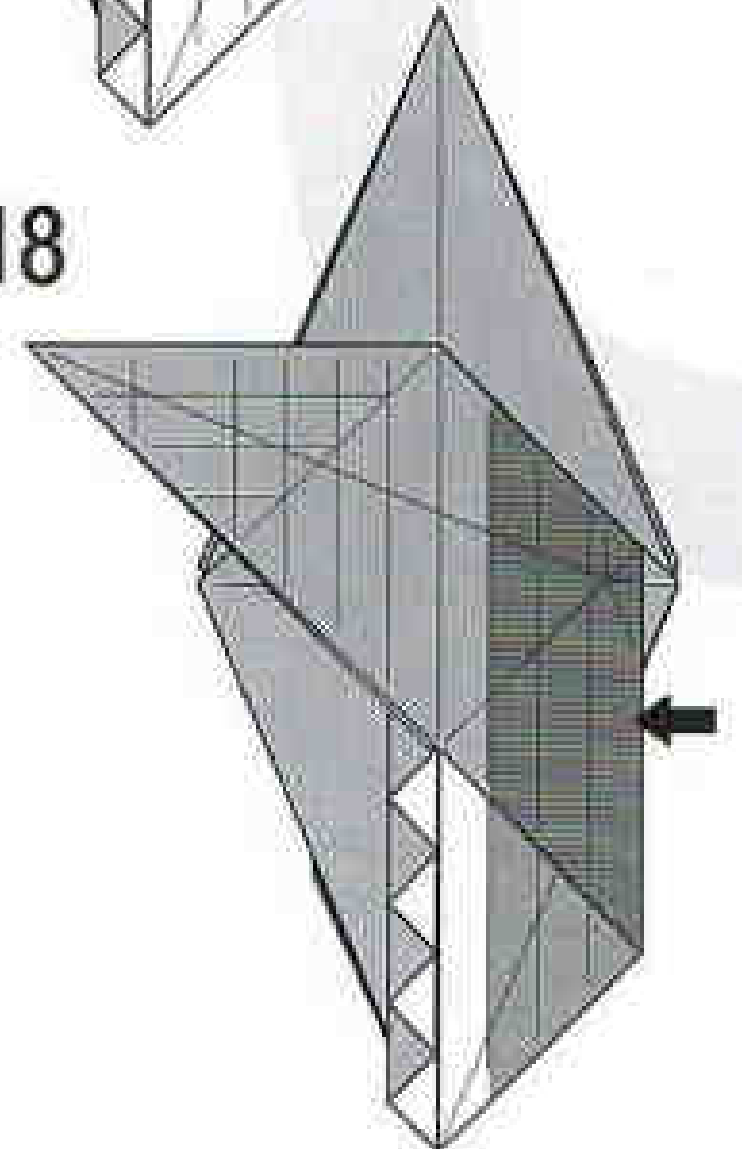

115

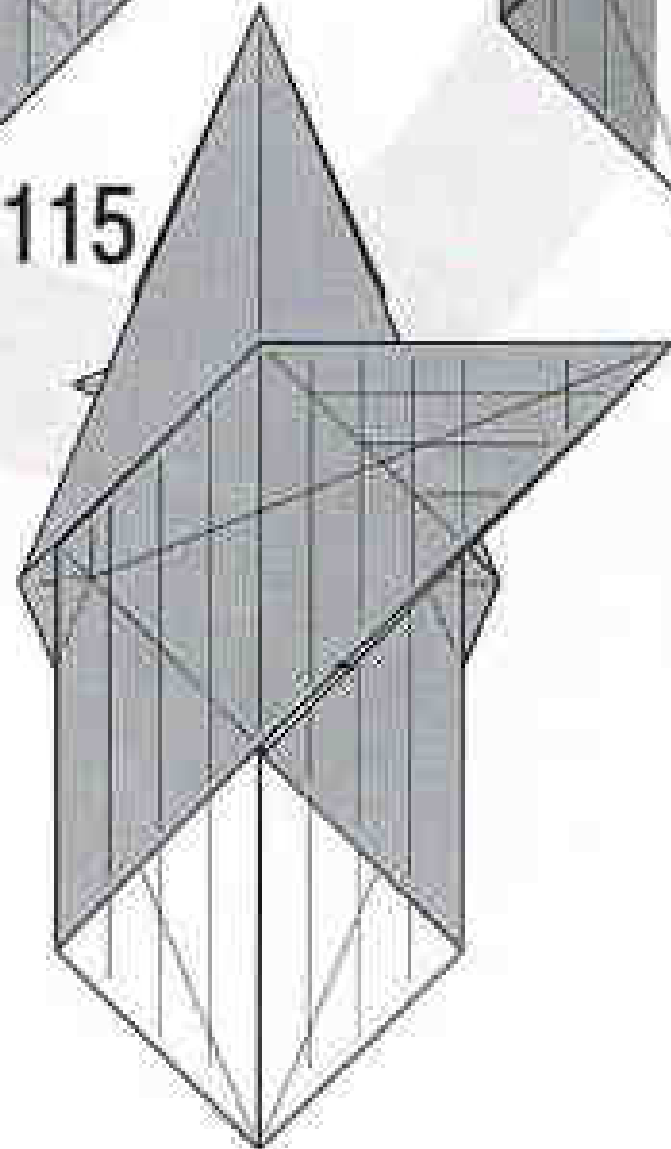

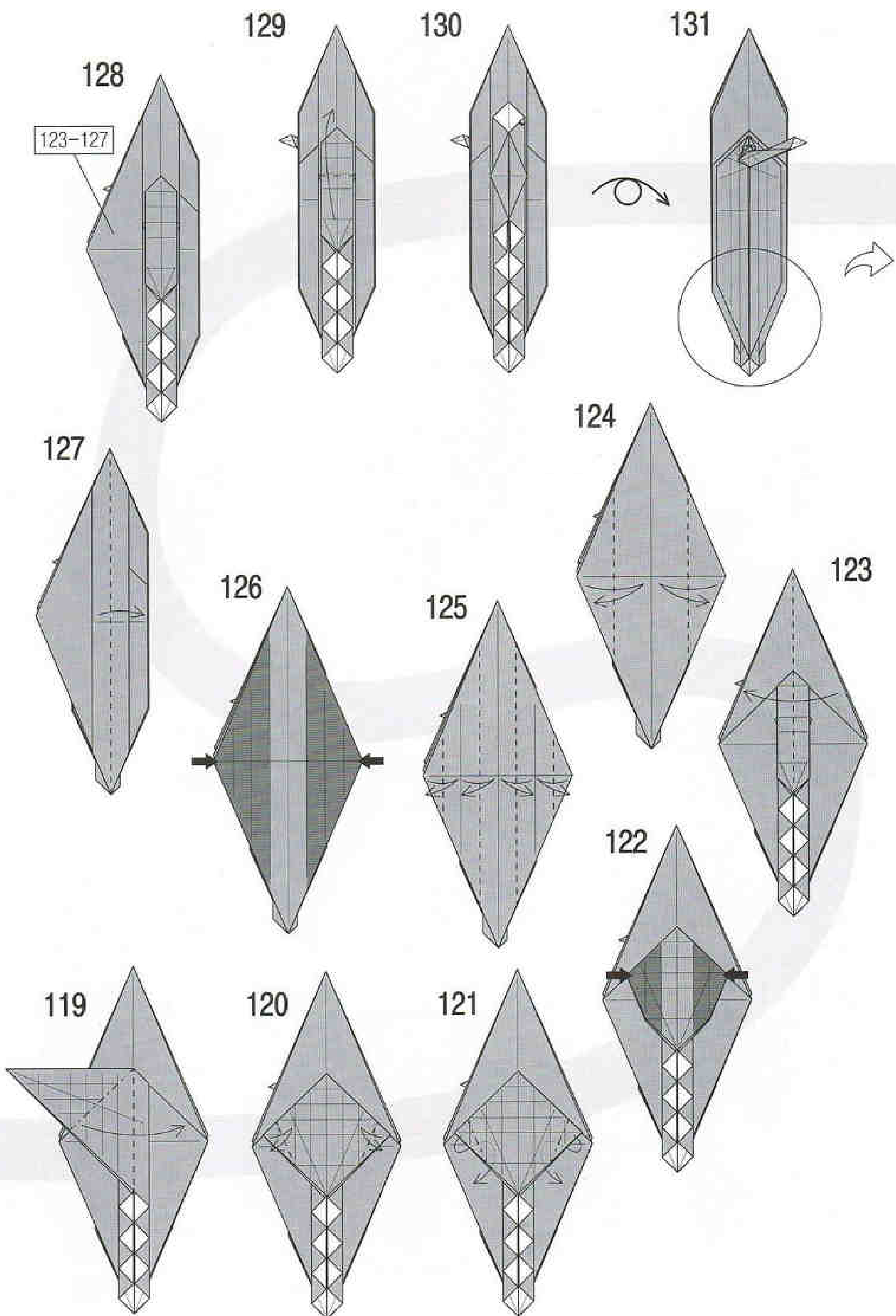

132

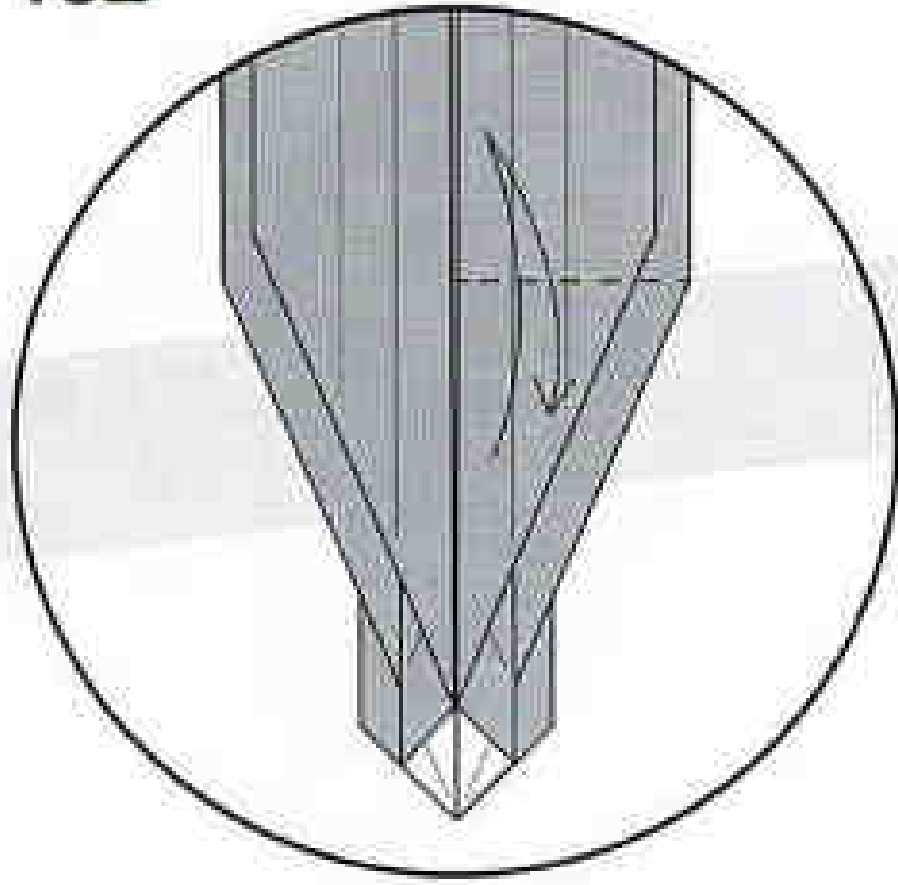

133

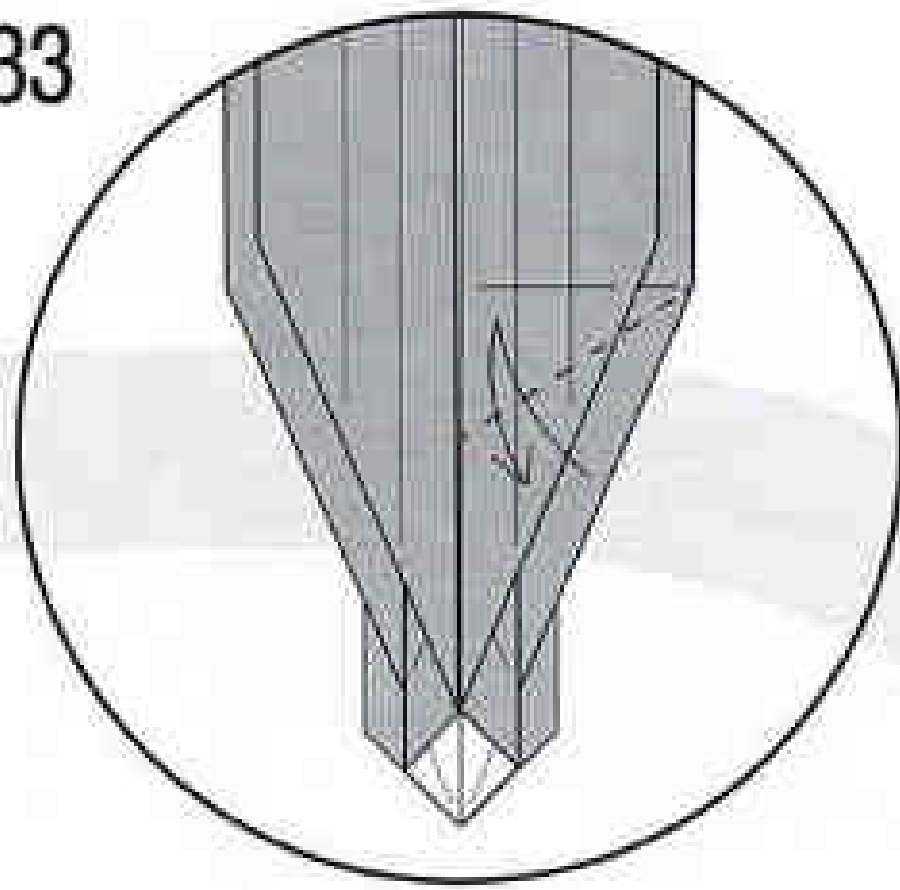

134

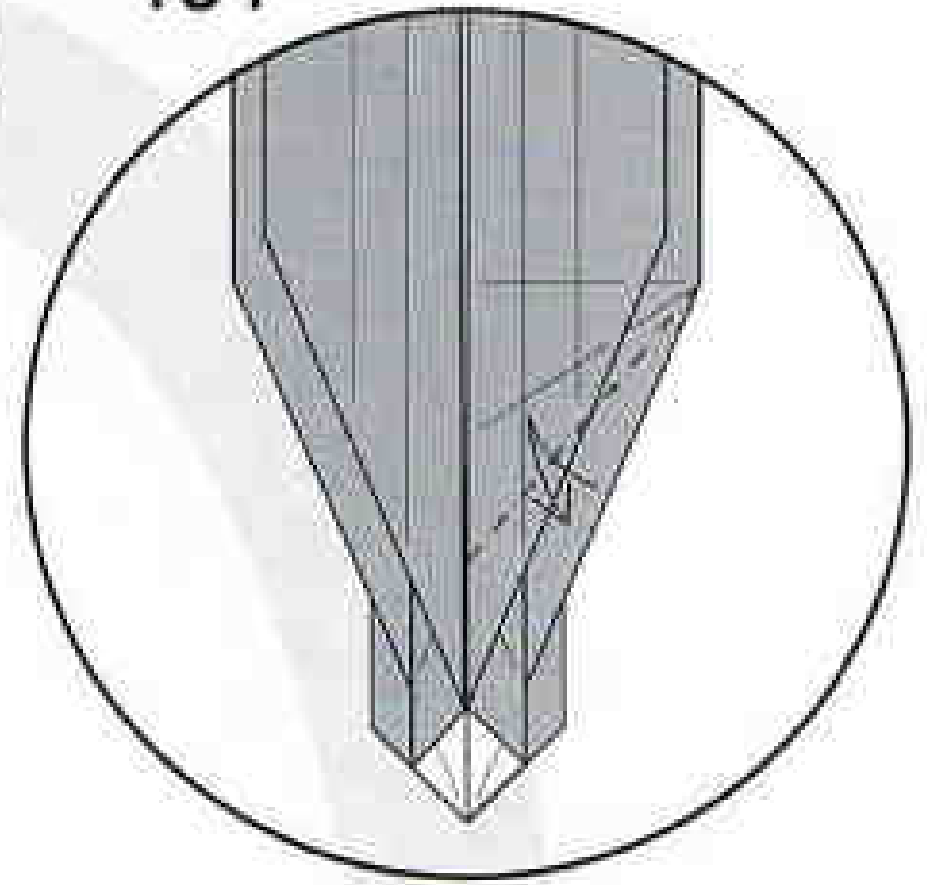

137

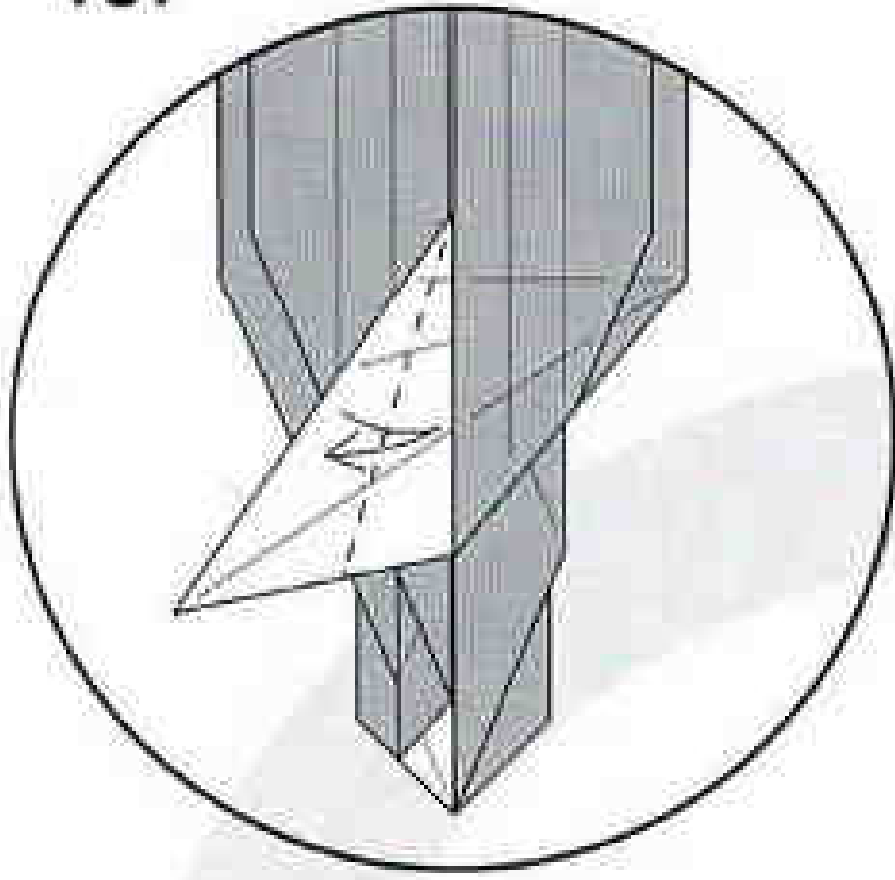

136

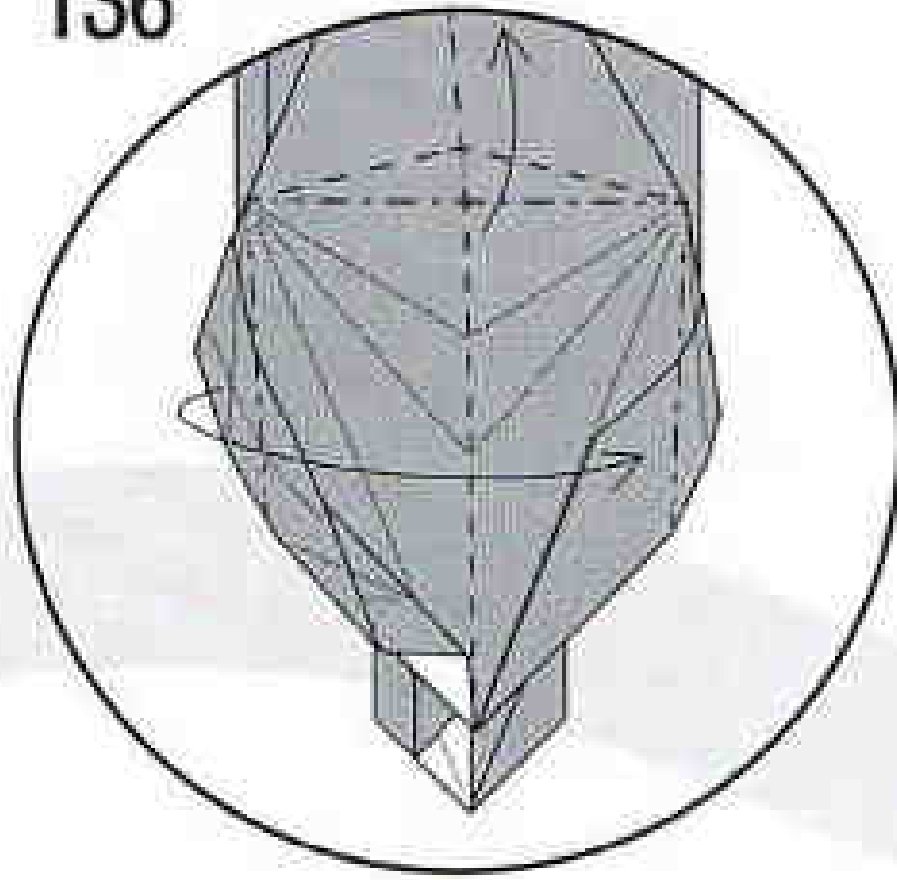

135

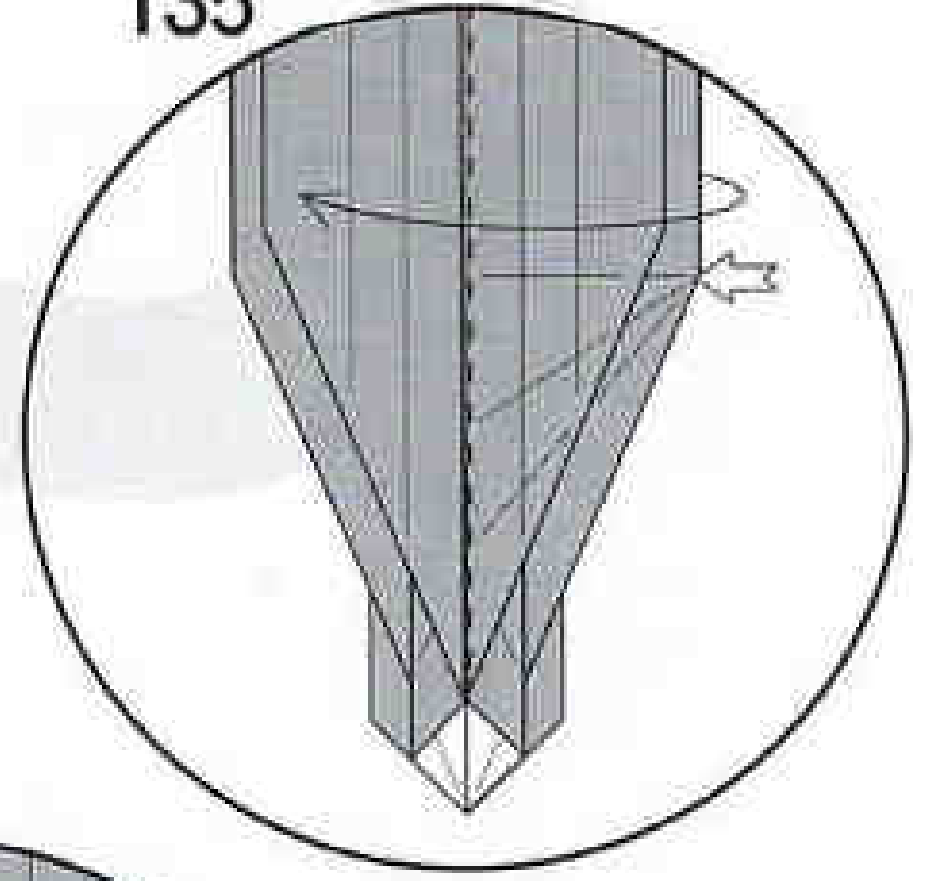

138

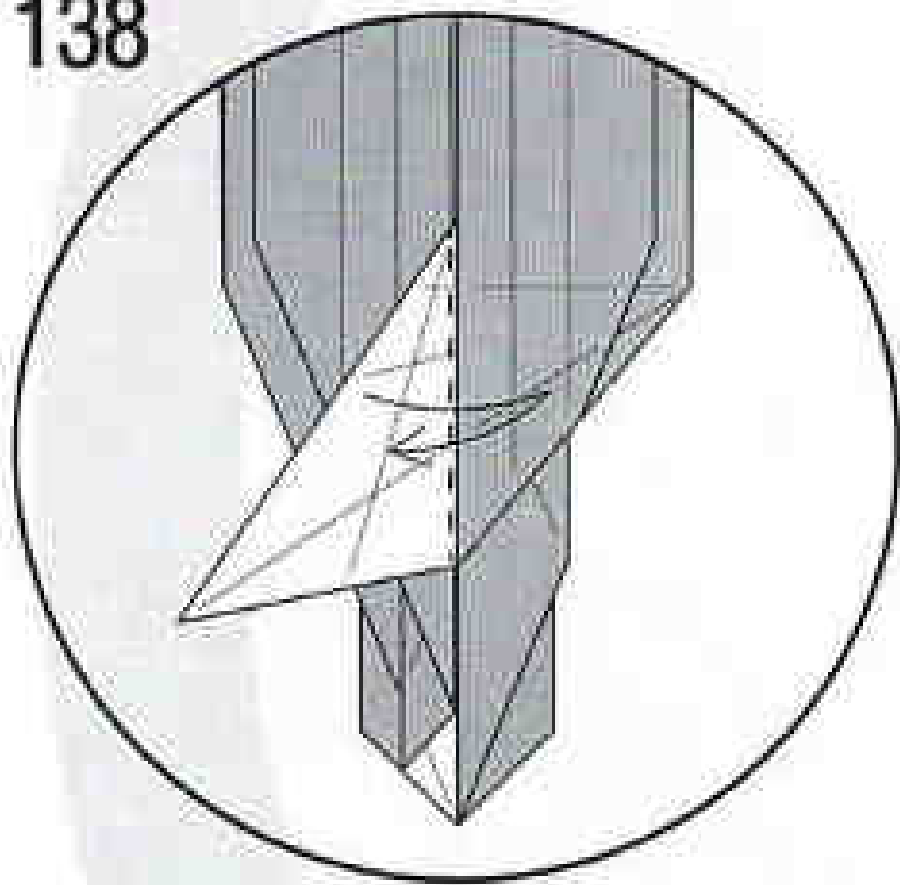

141

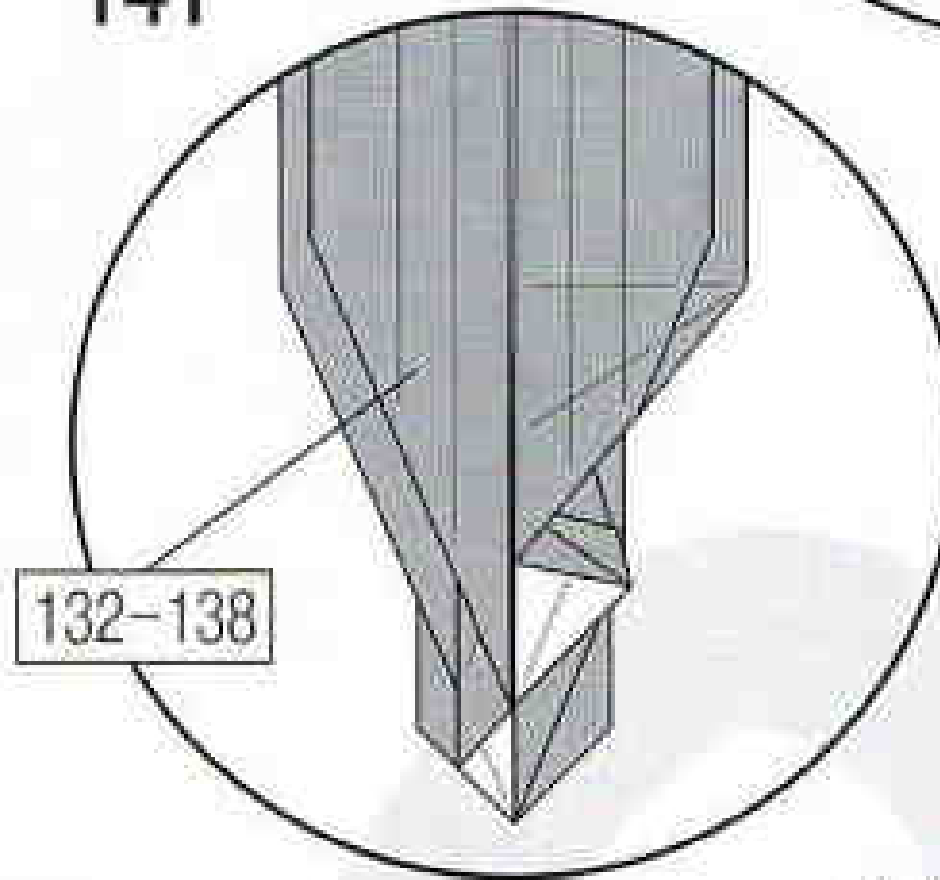

139

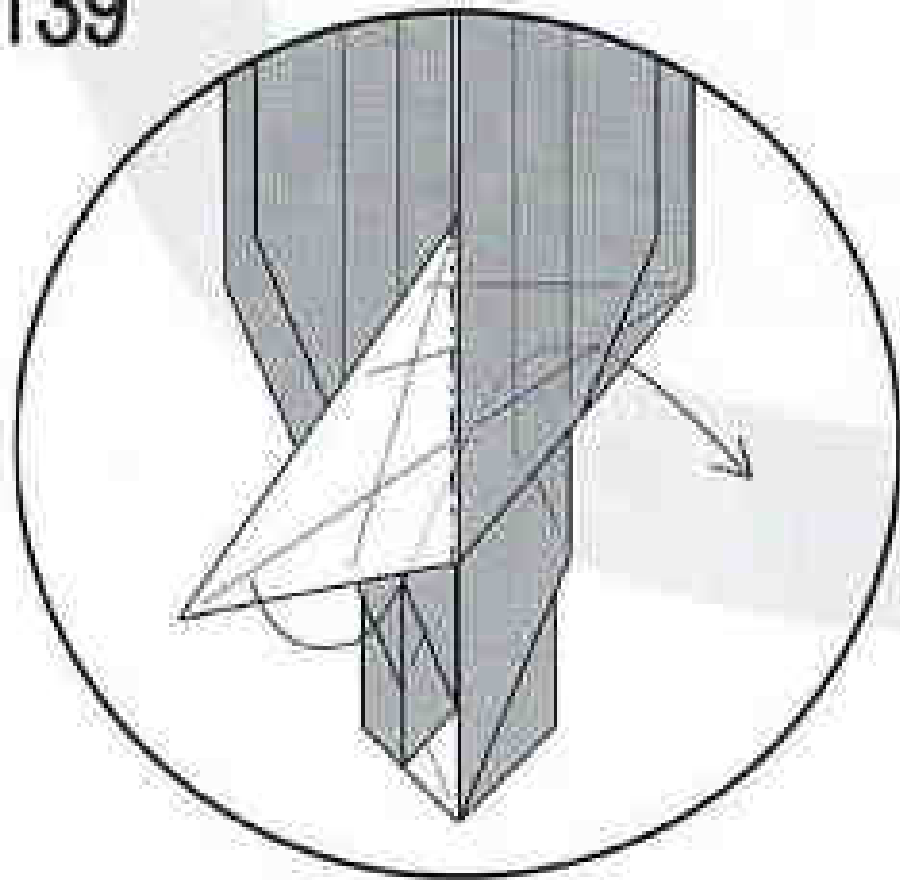

140

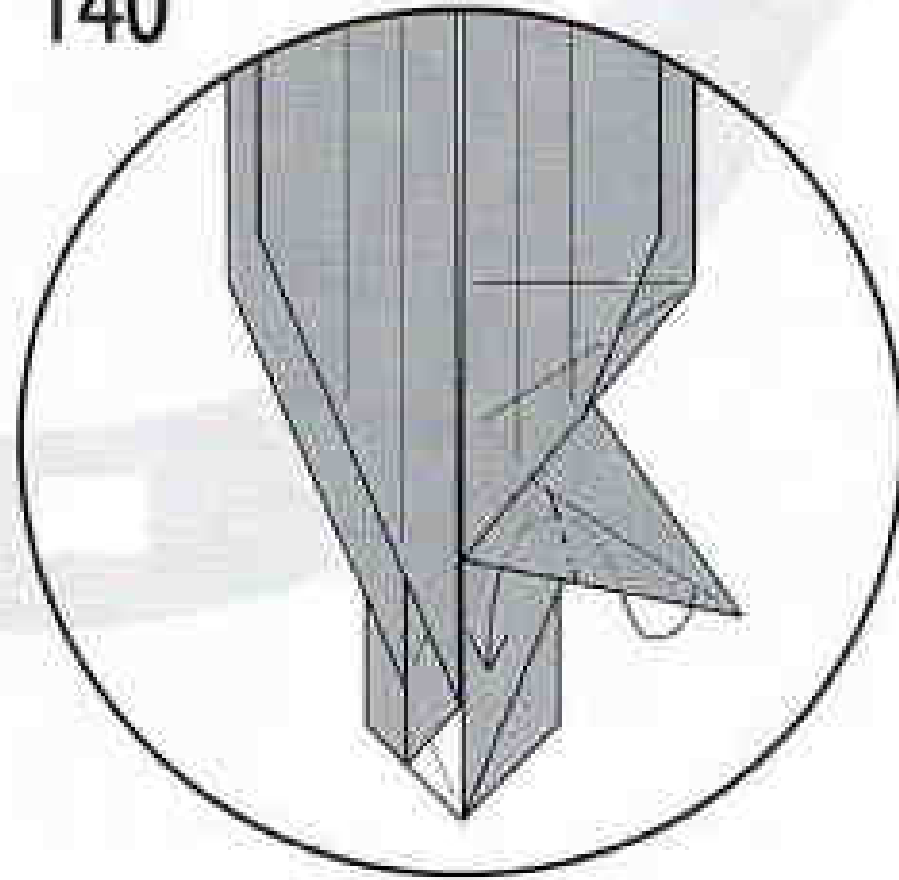

142

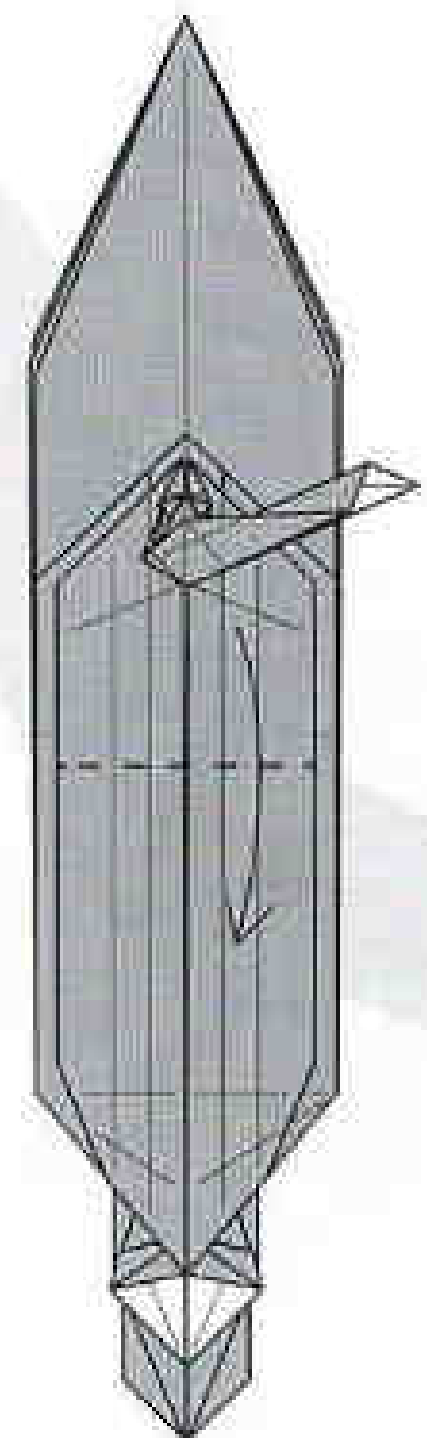

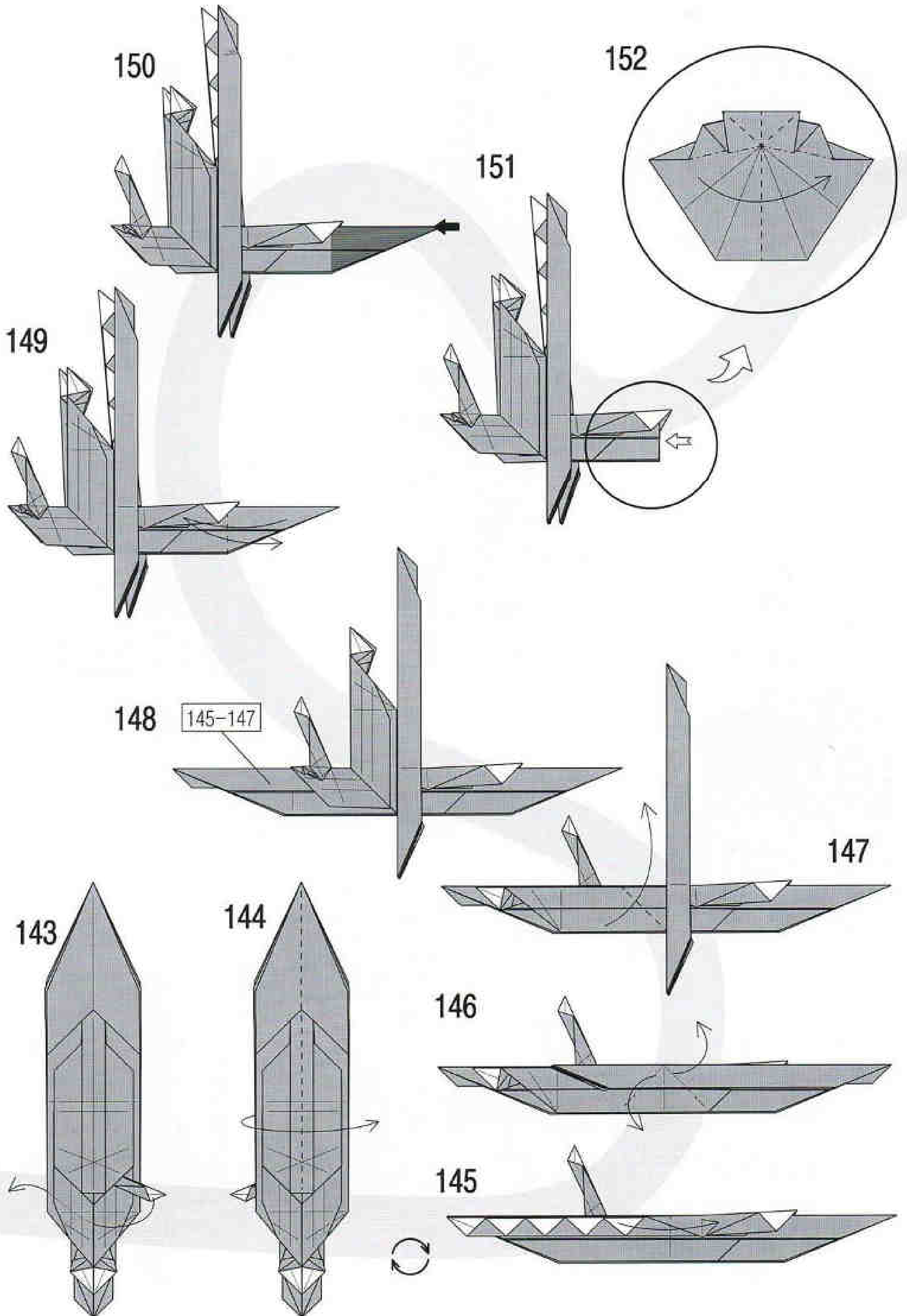

153

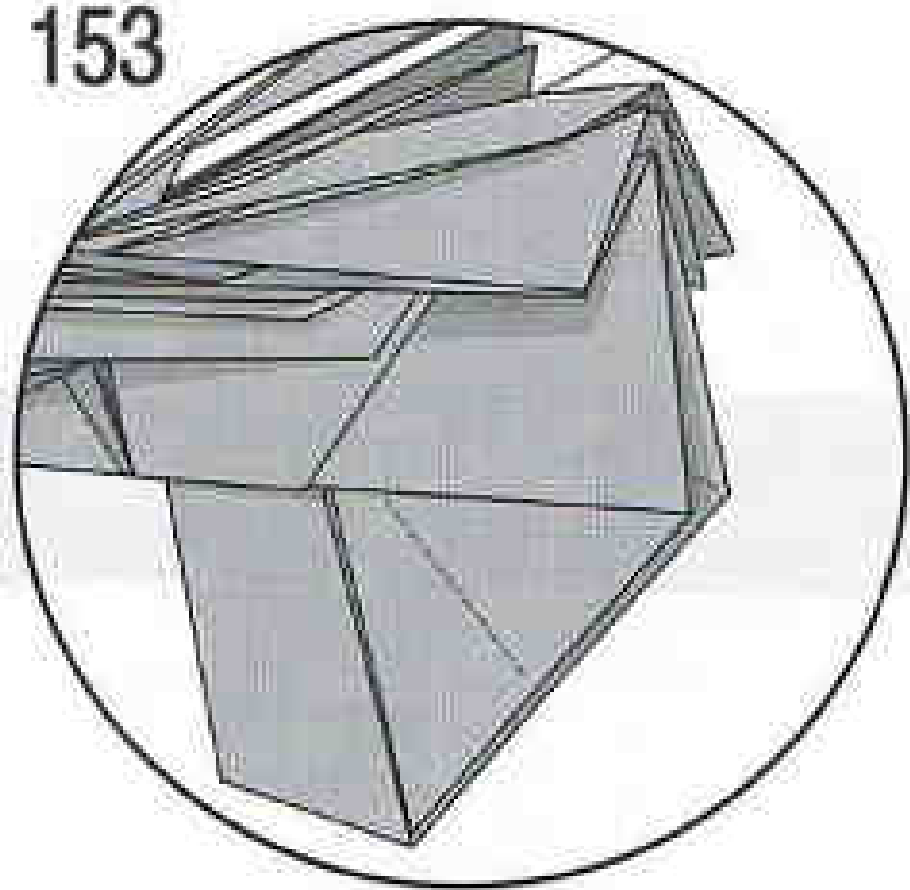

154

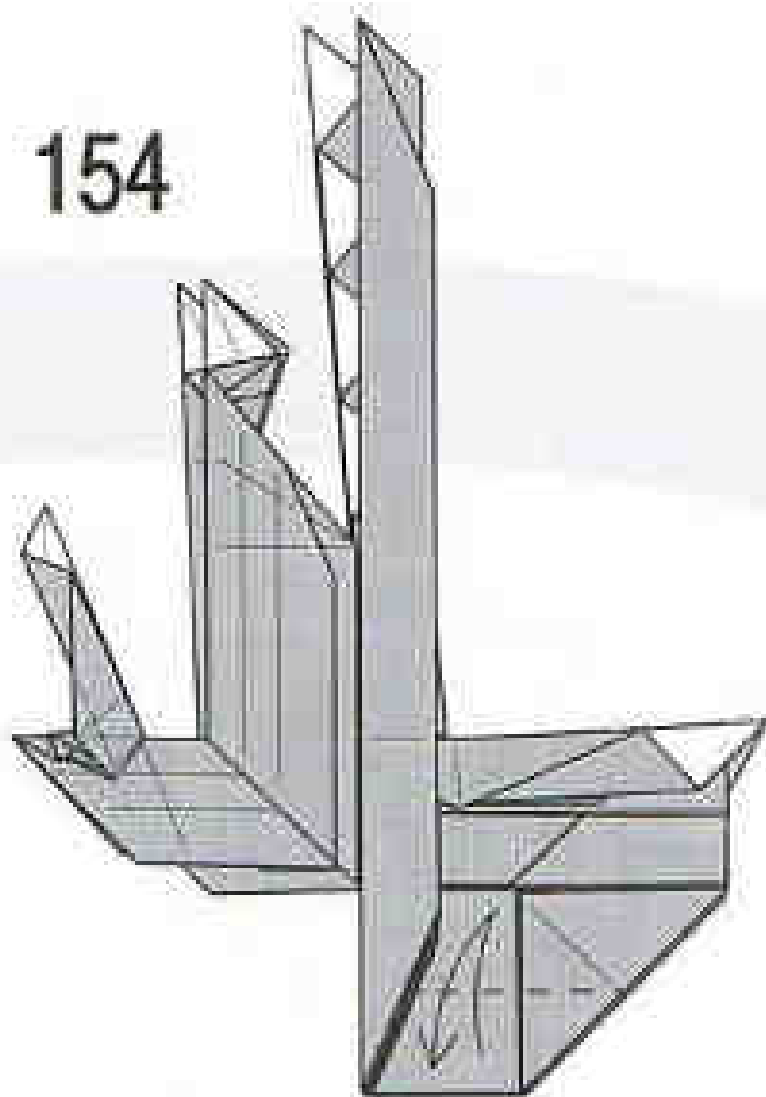

155

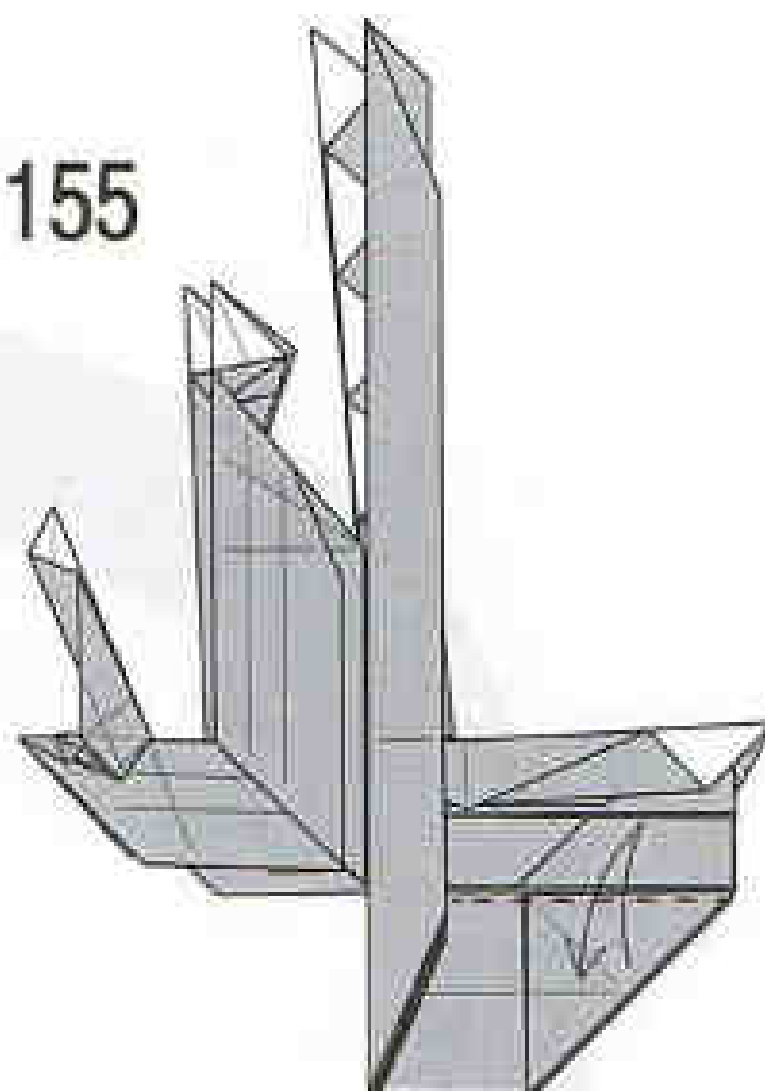

157

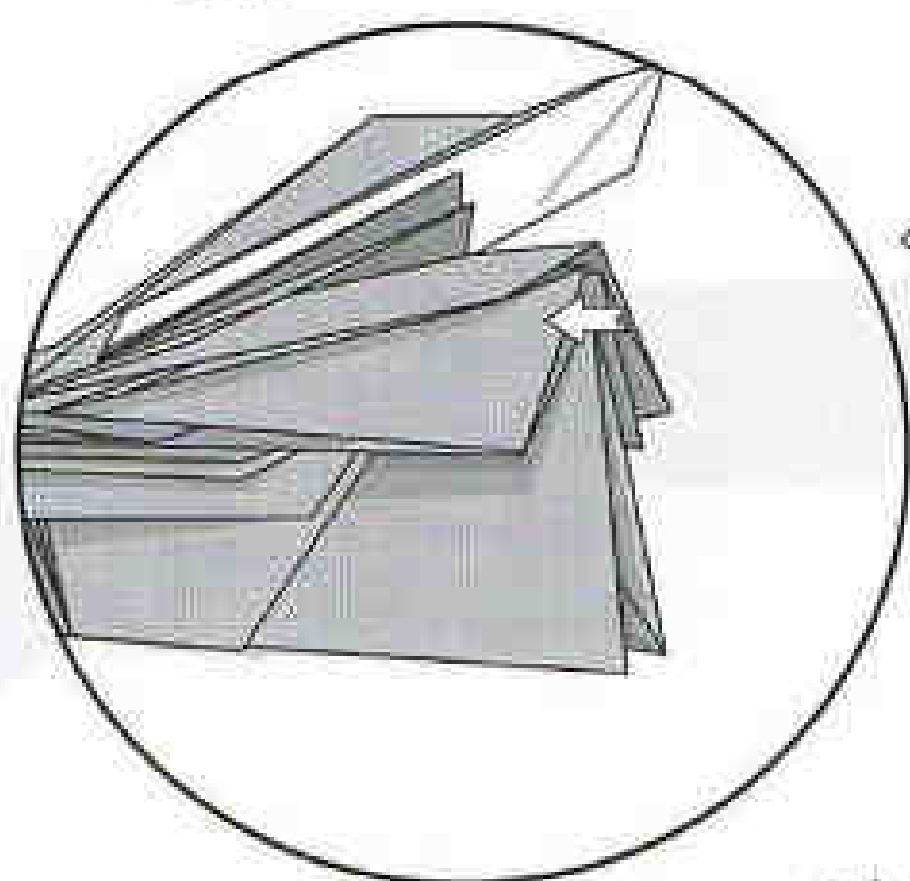

156

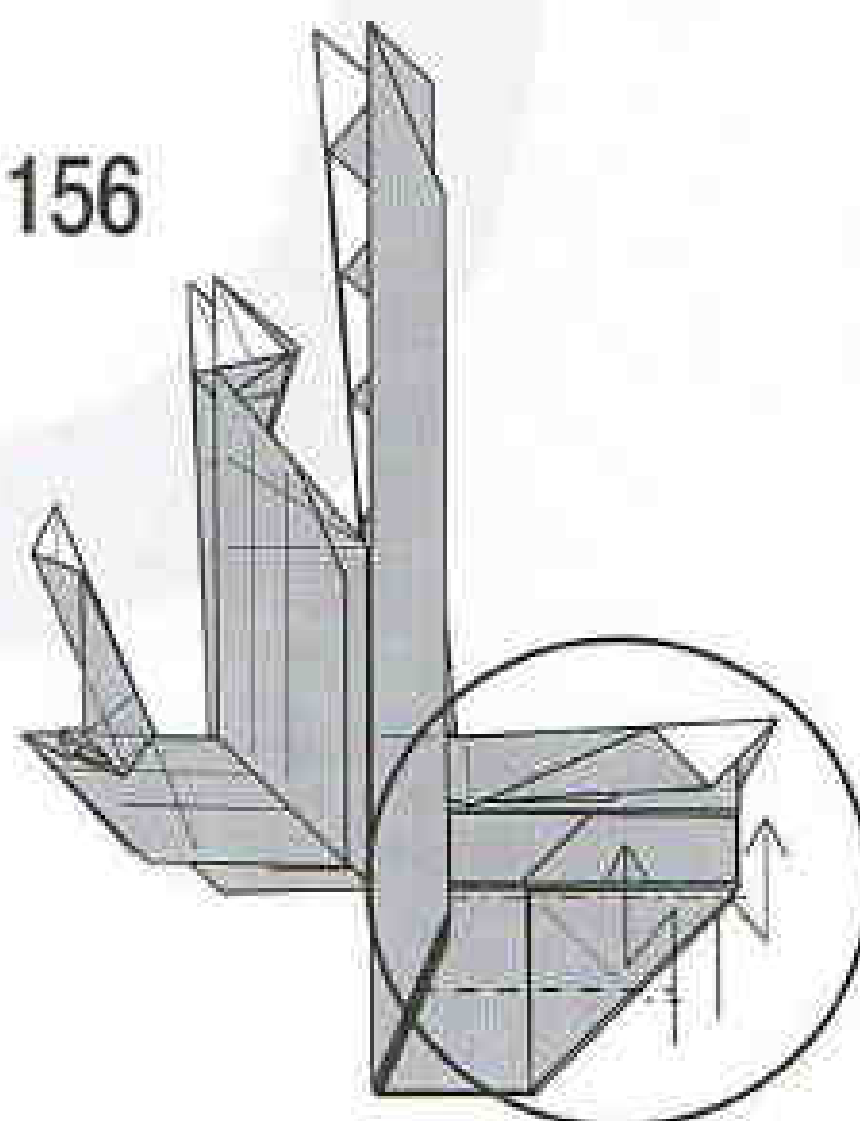

158

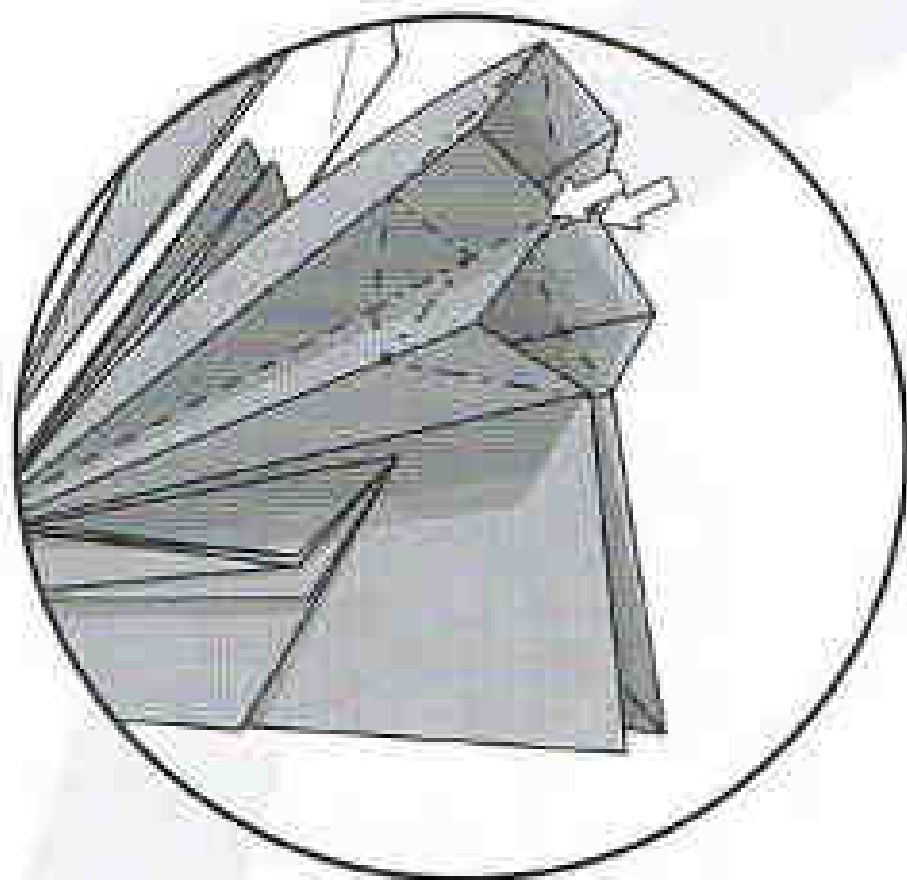

161

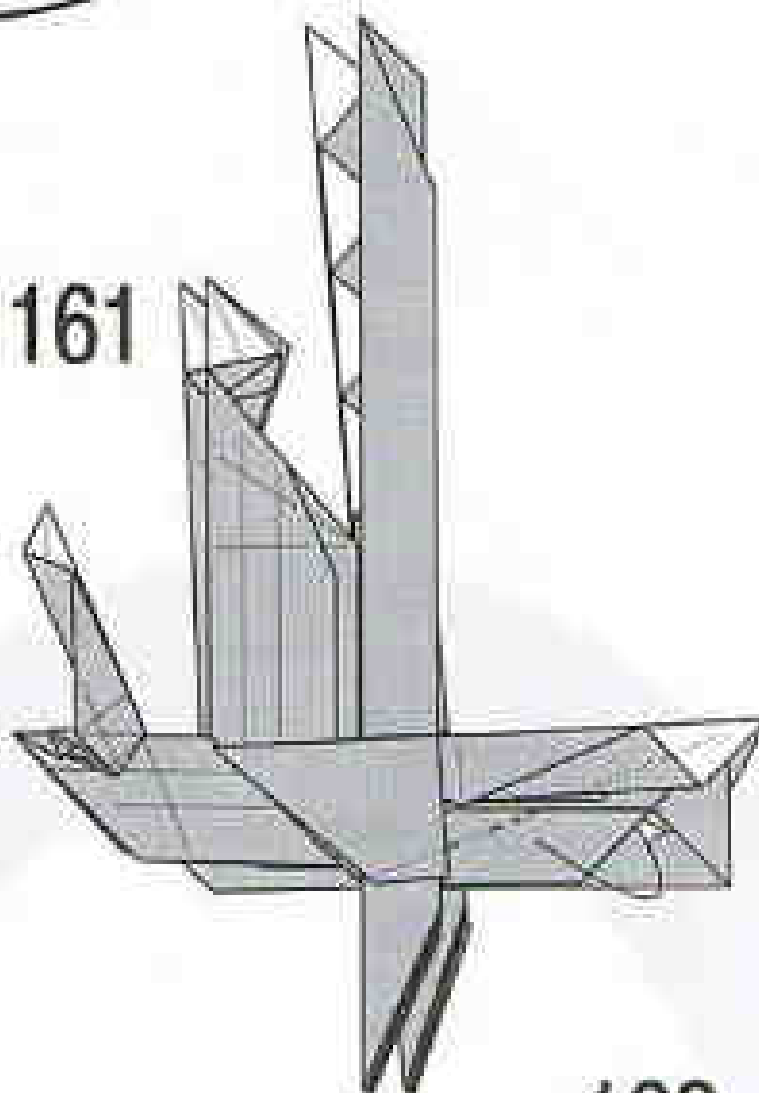

160

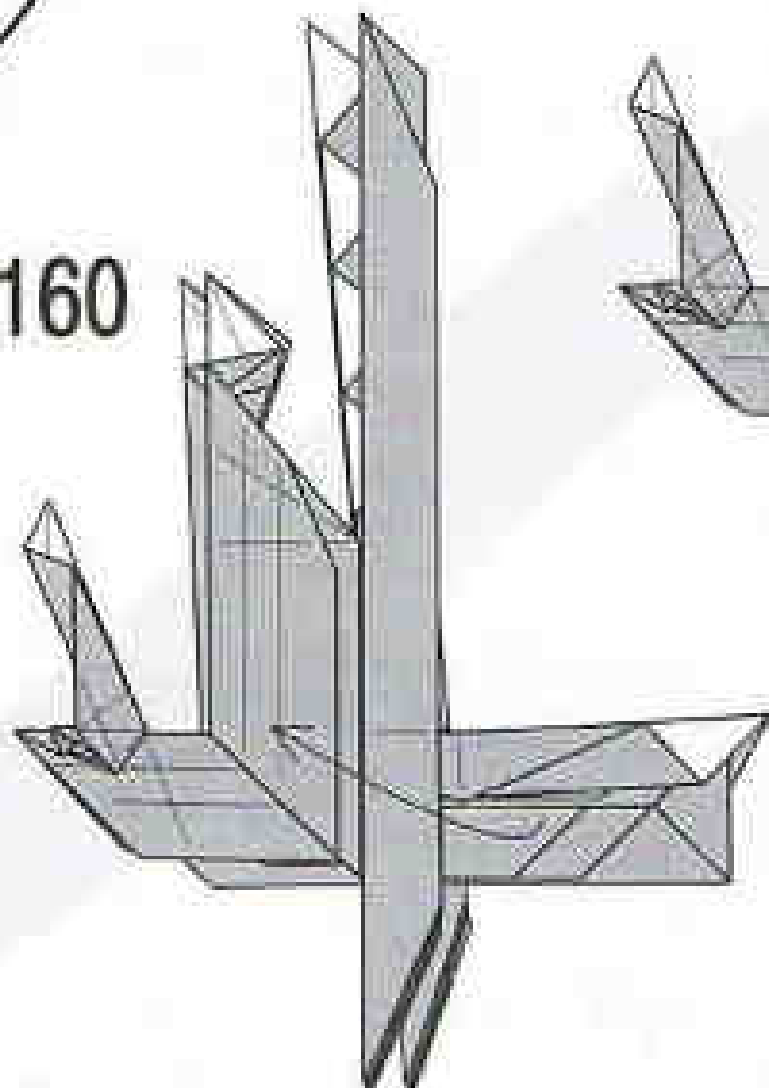

159

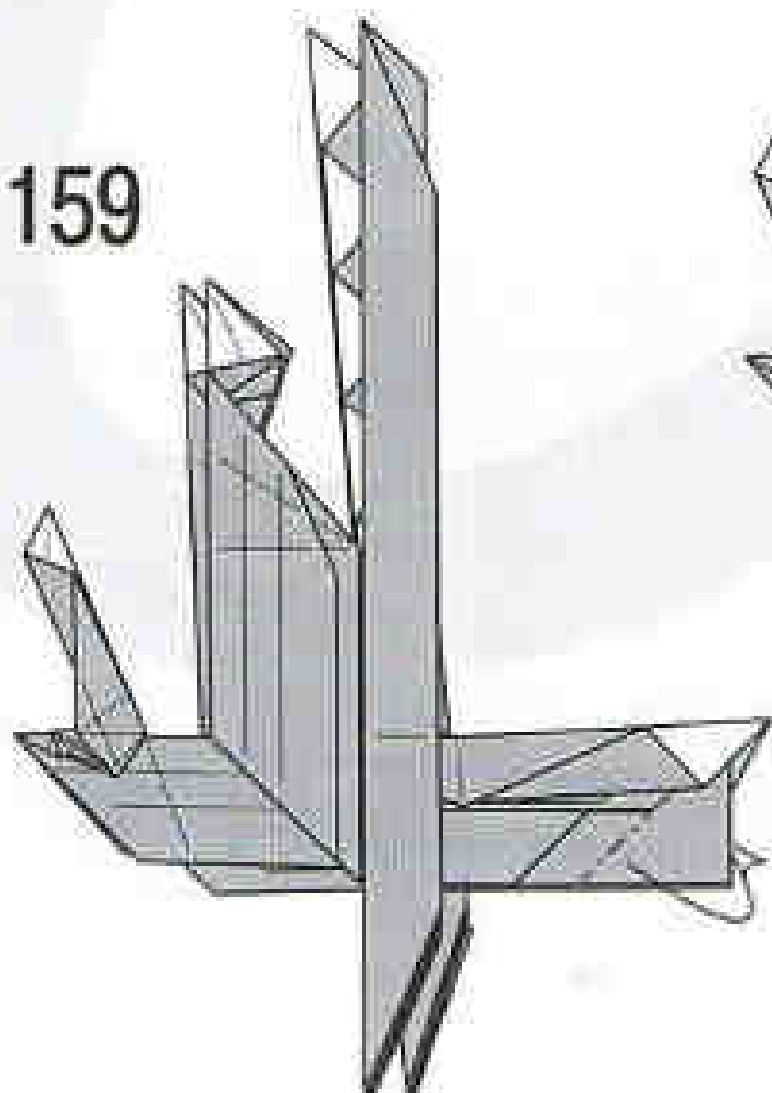

162

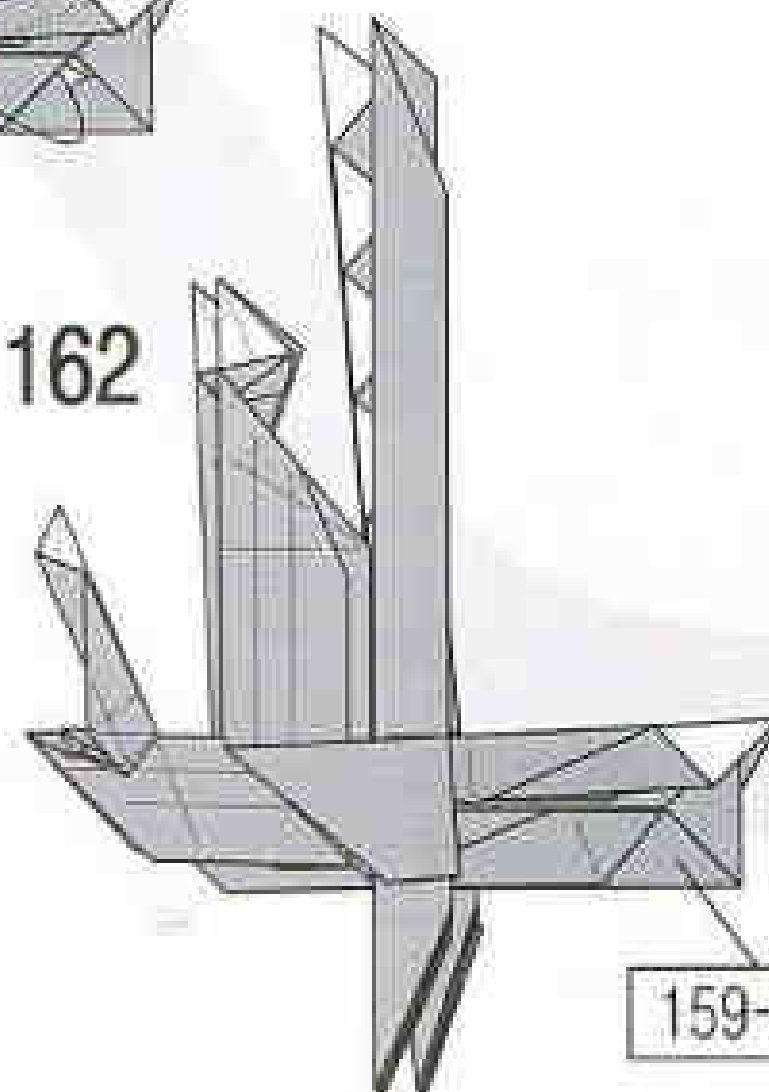

159-161

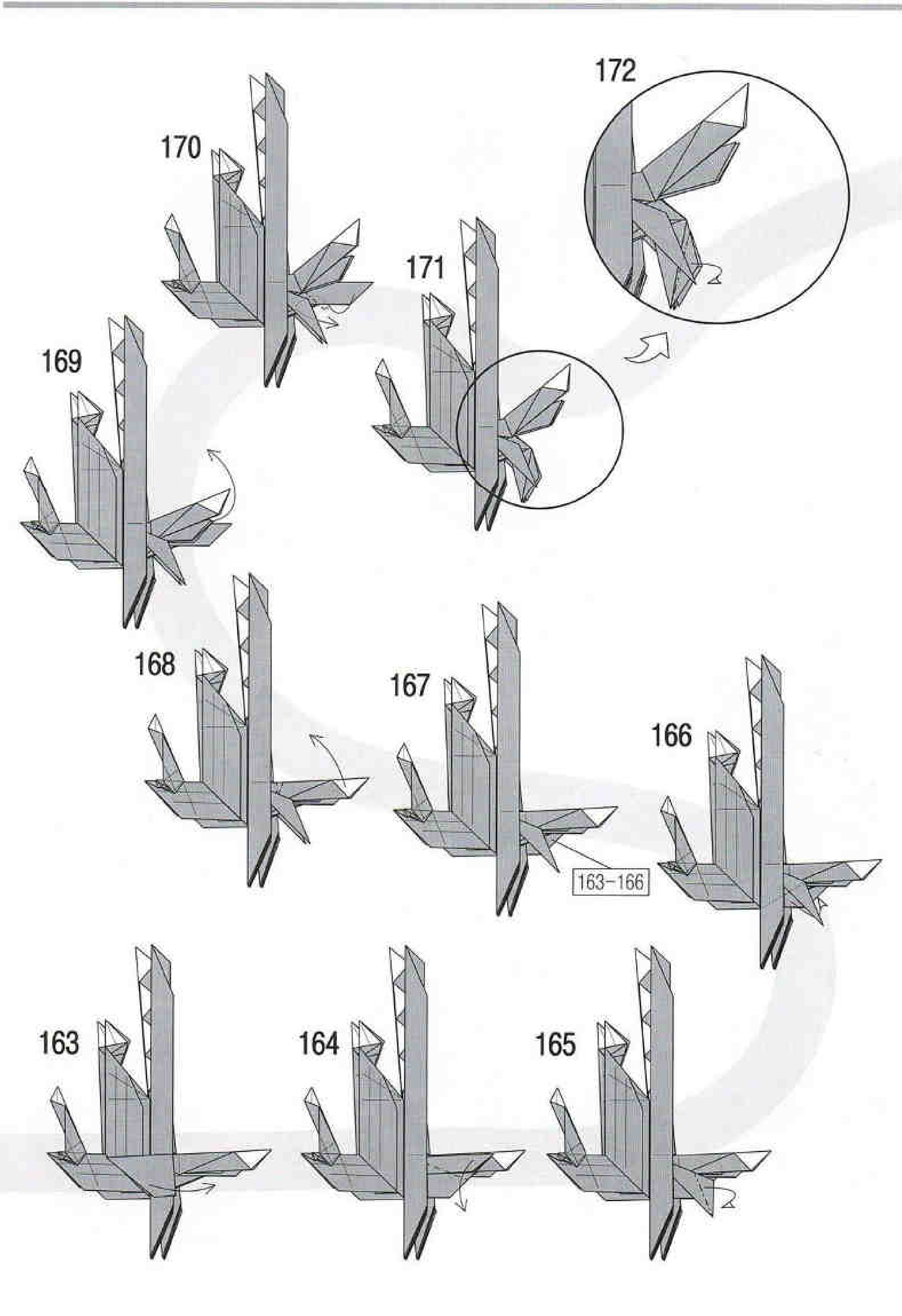

170

172

171

169

168

167

166

163-166

163

164

165

173

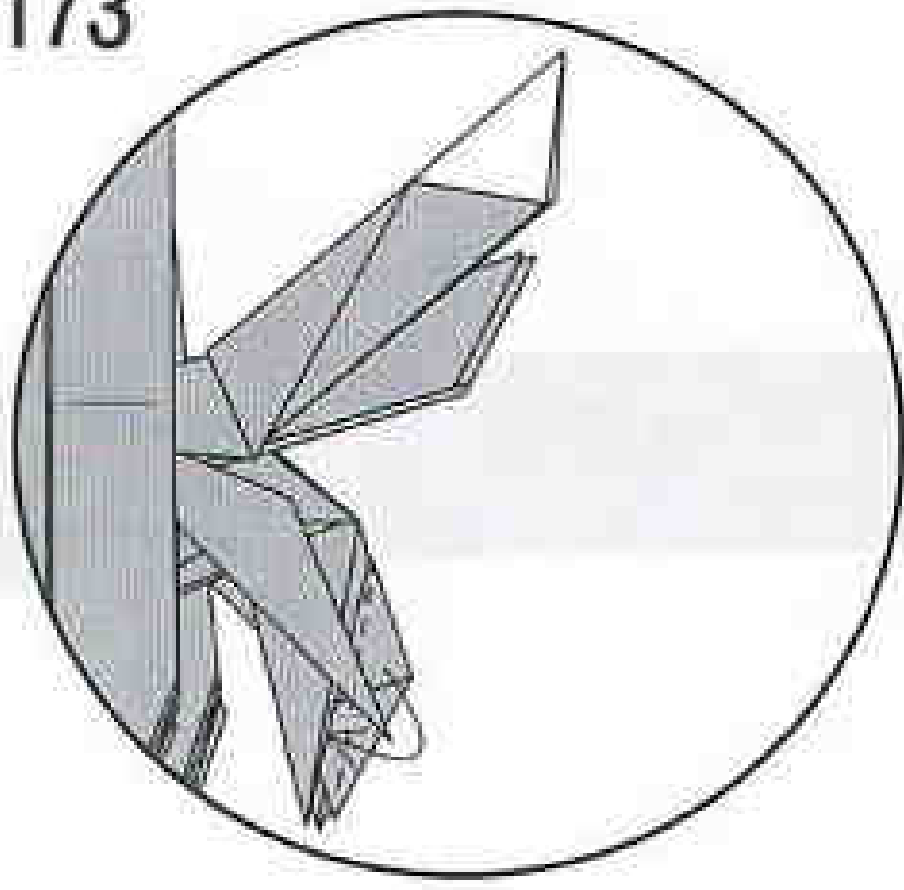

174

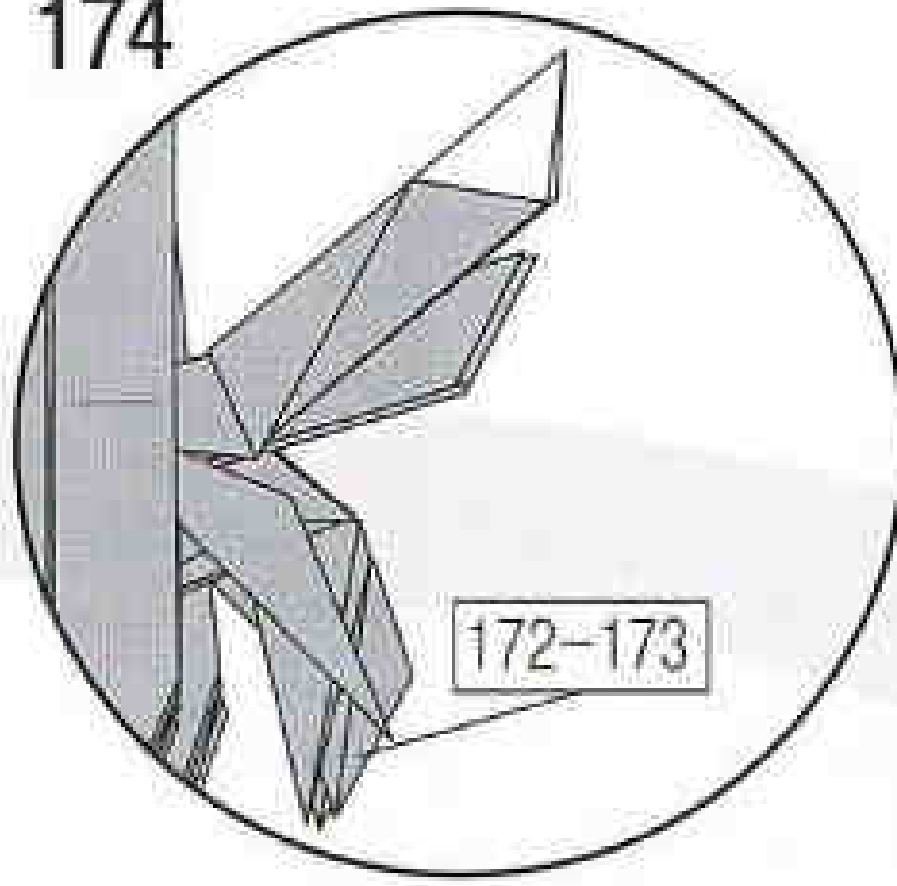

175

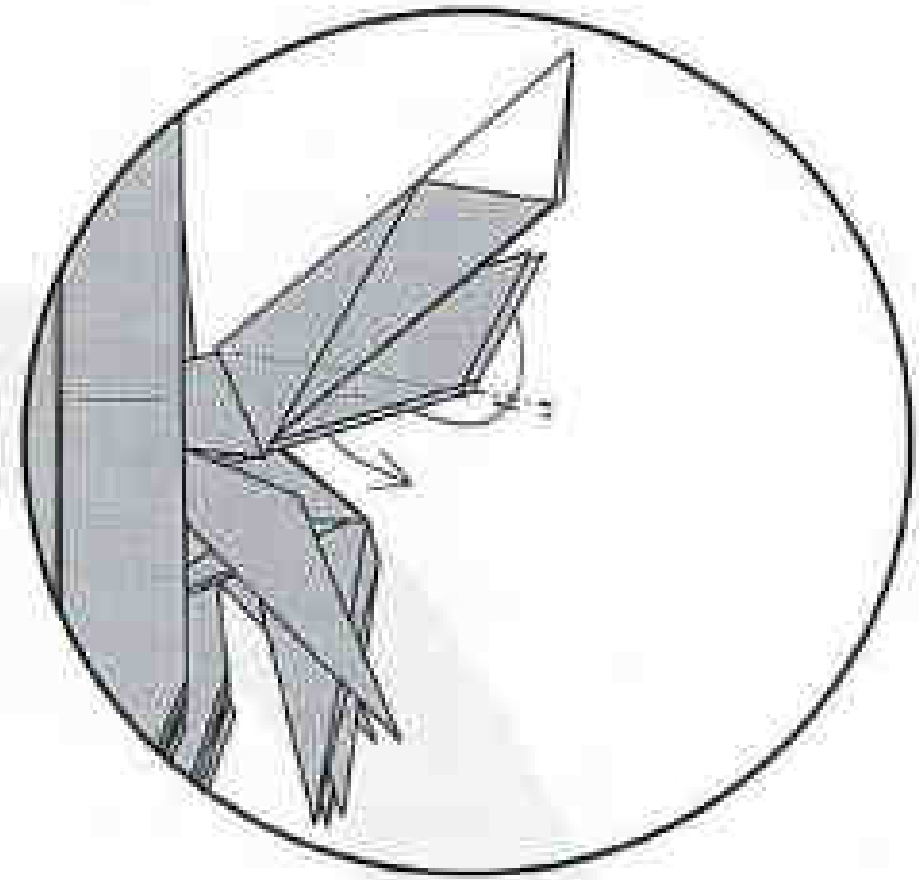

177

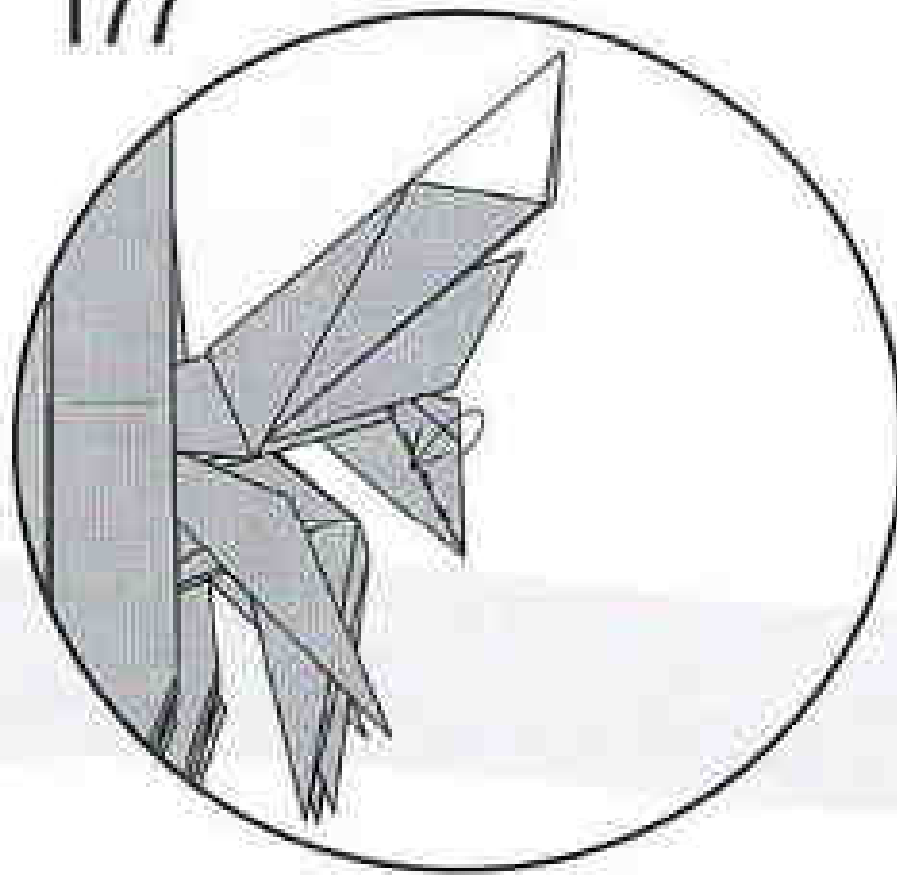

176

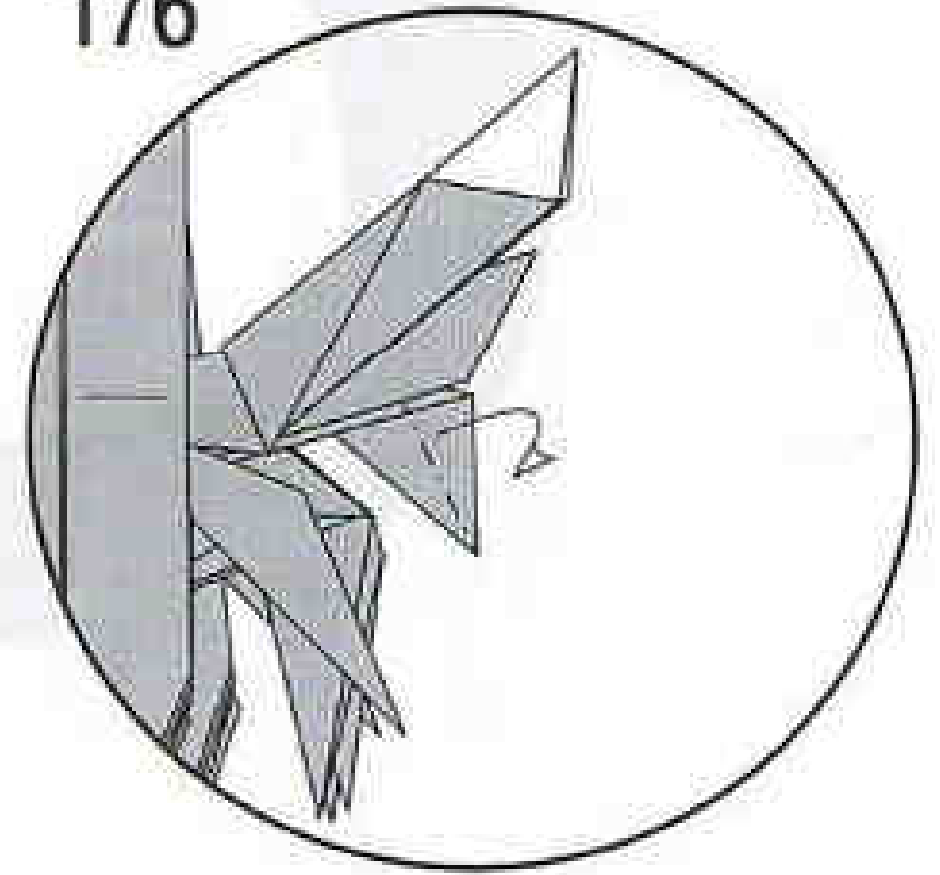

178

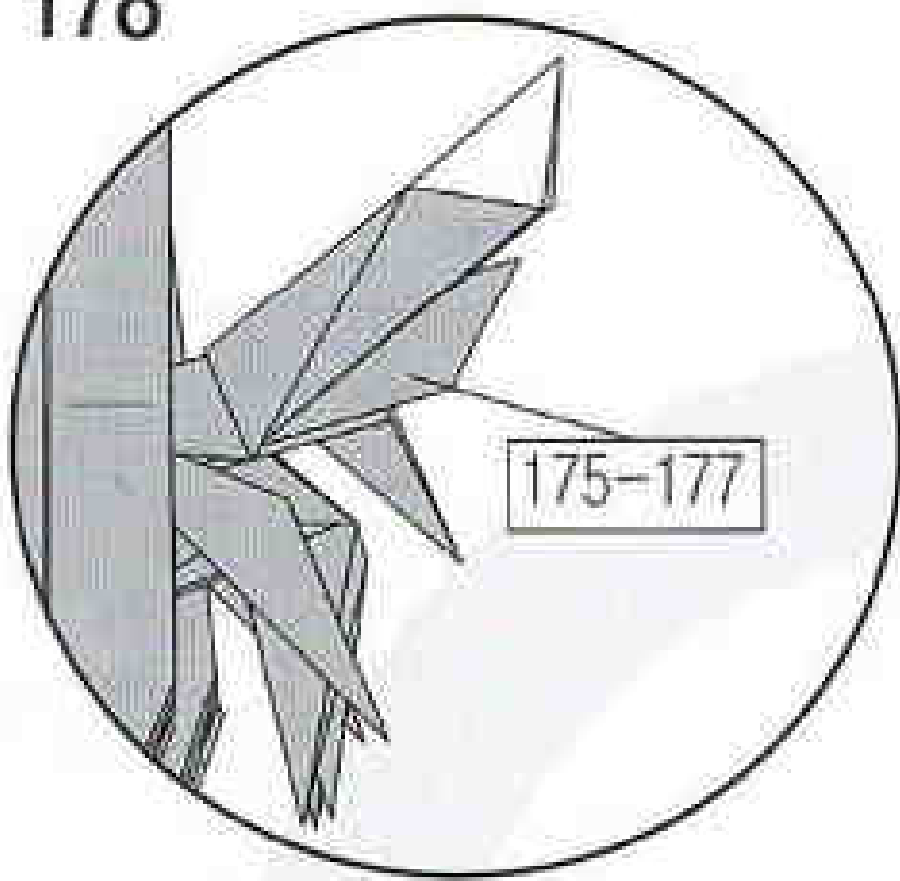

179

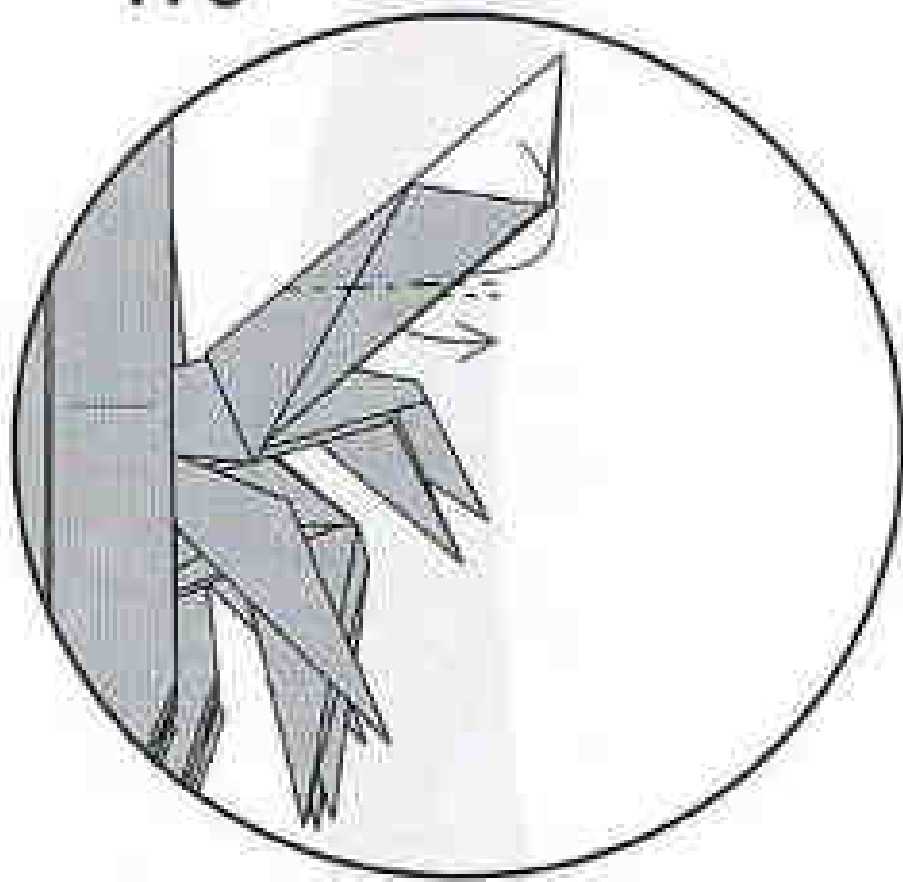

182

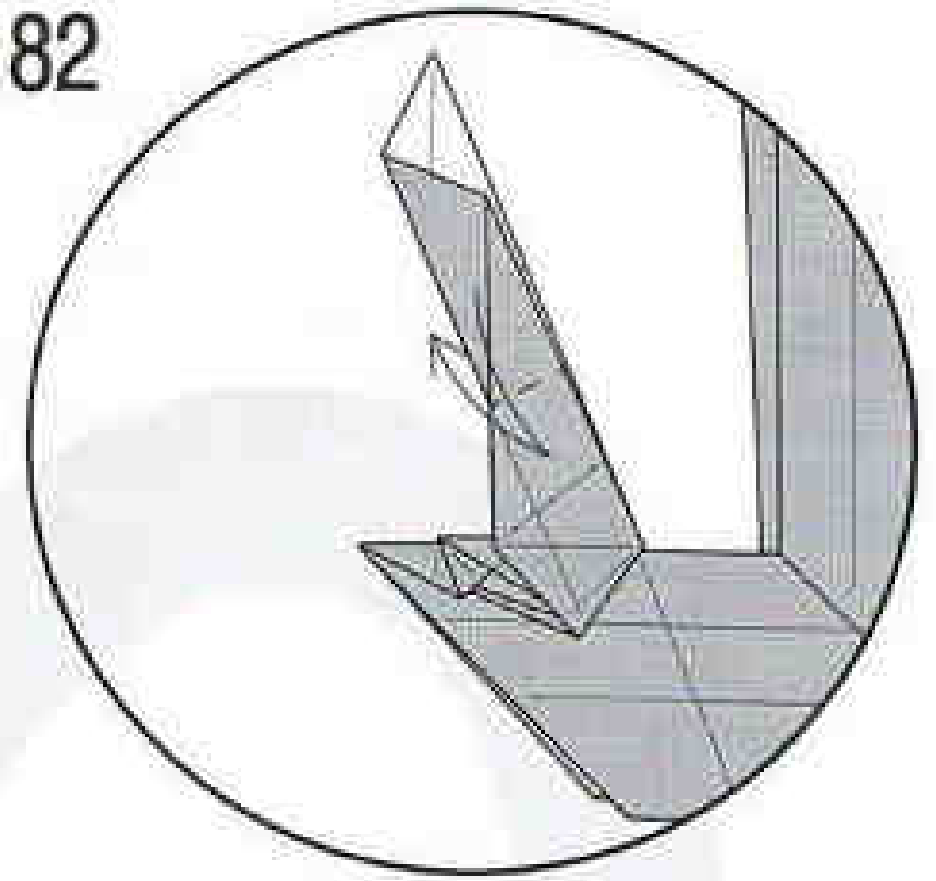

180

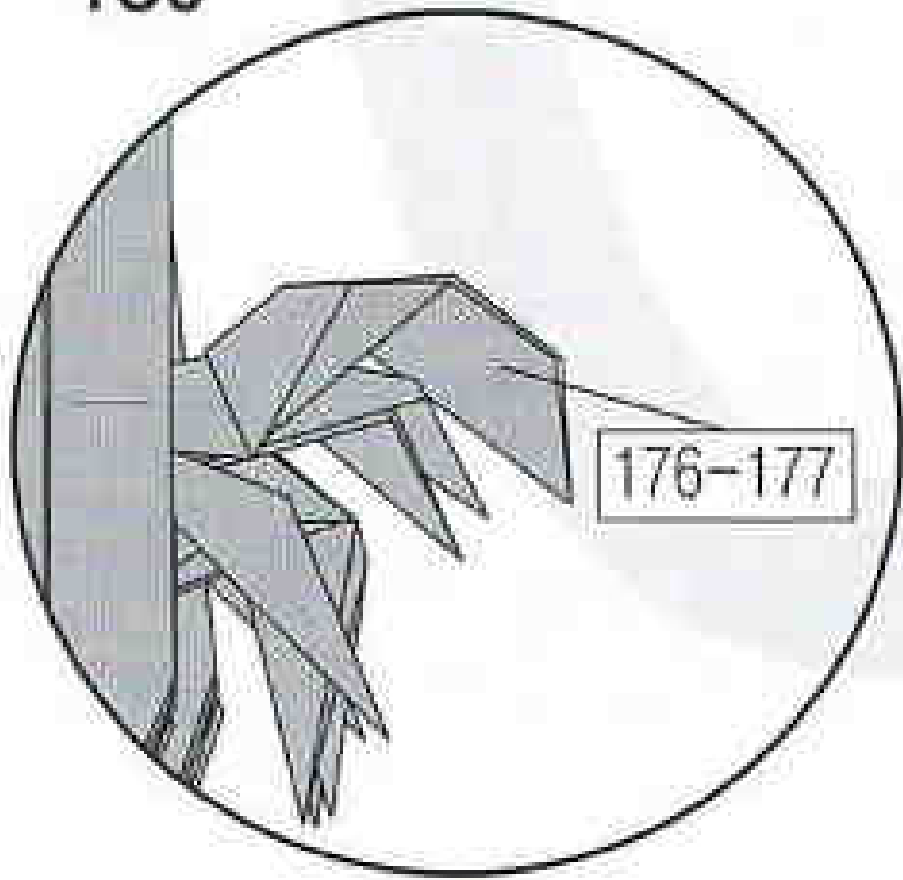

181

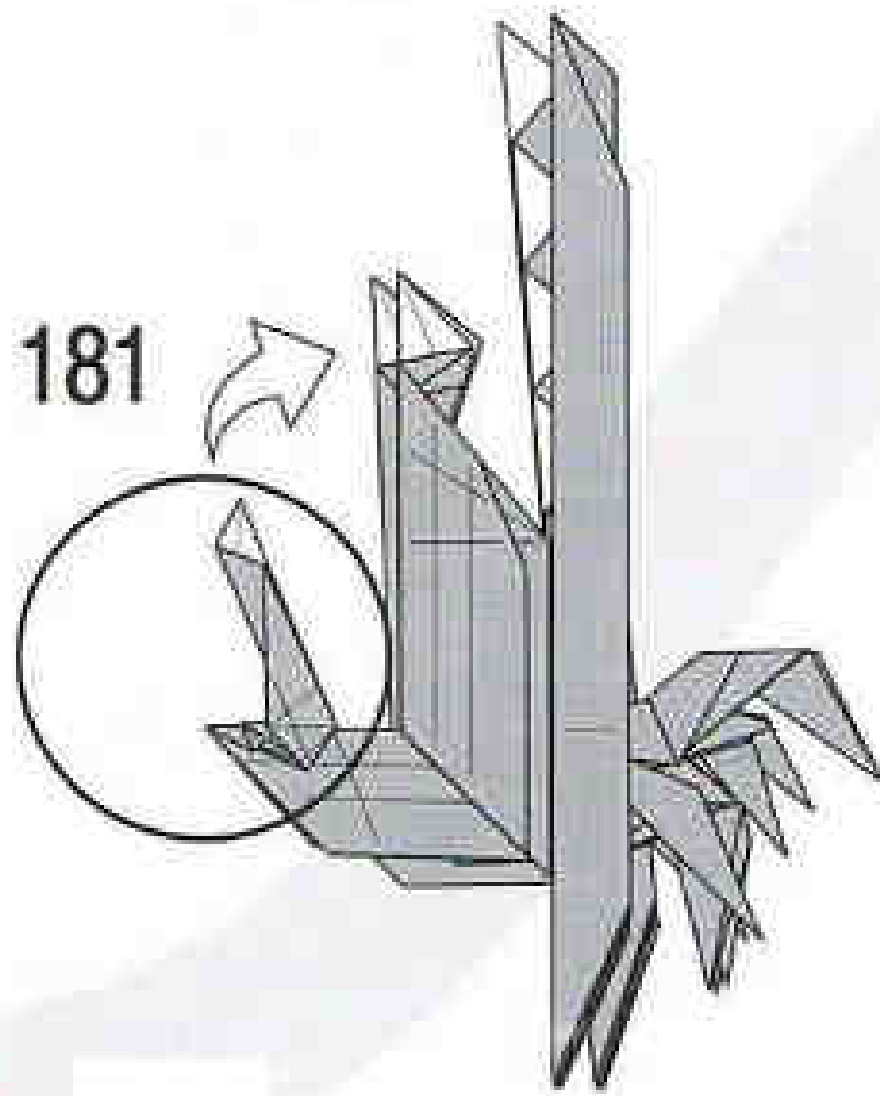

183

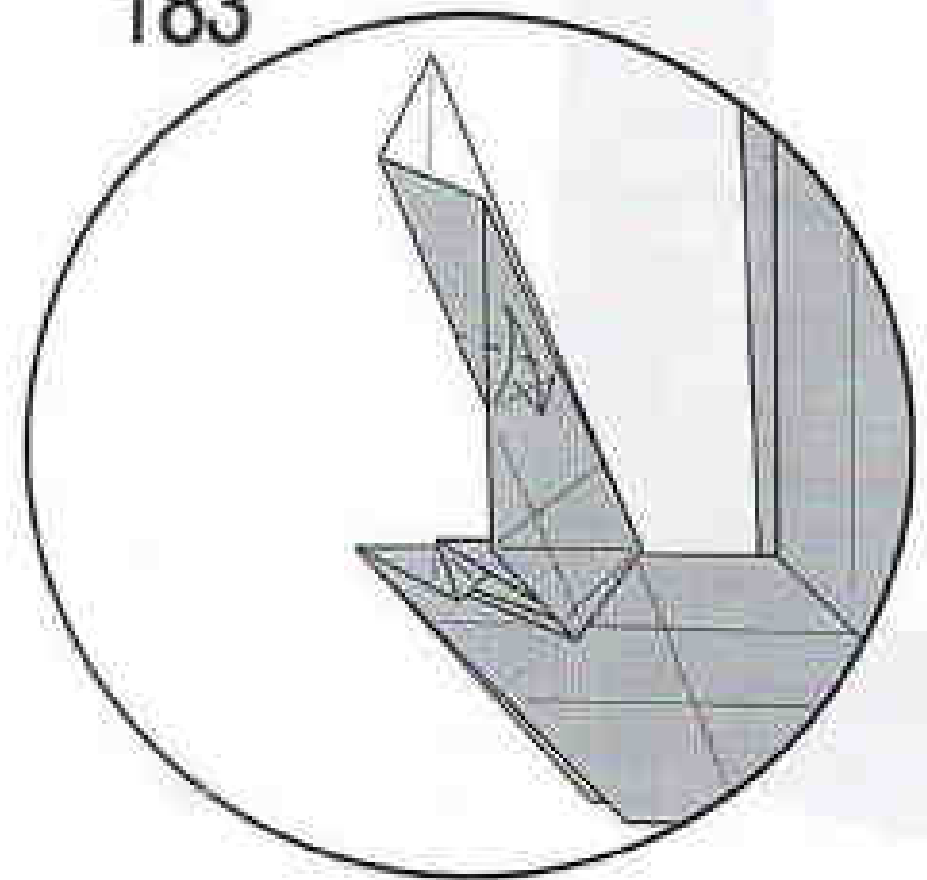

190

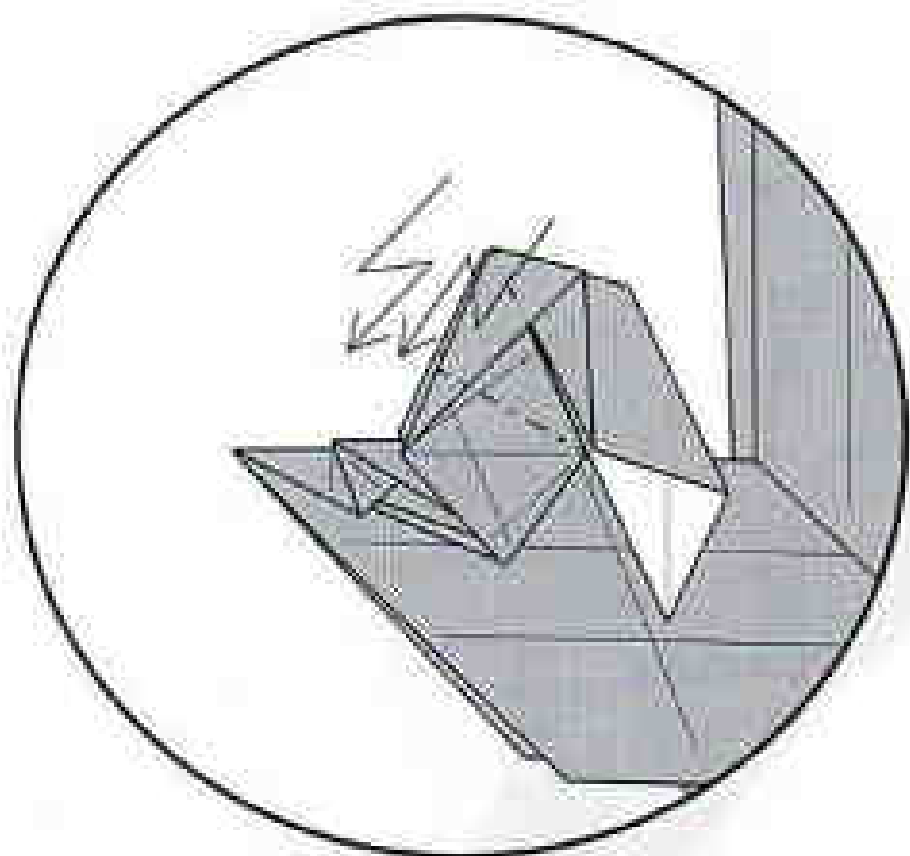

191

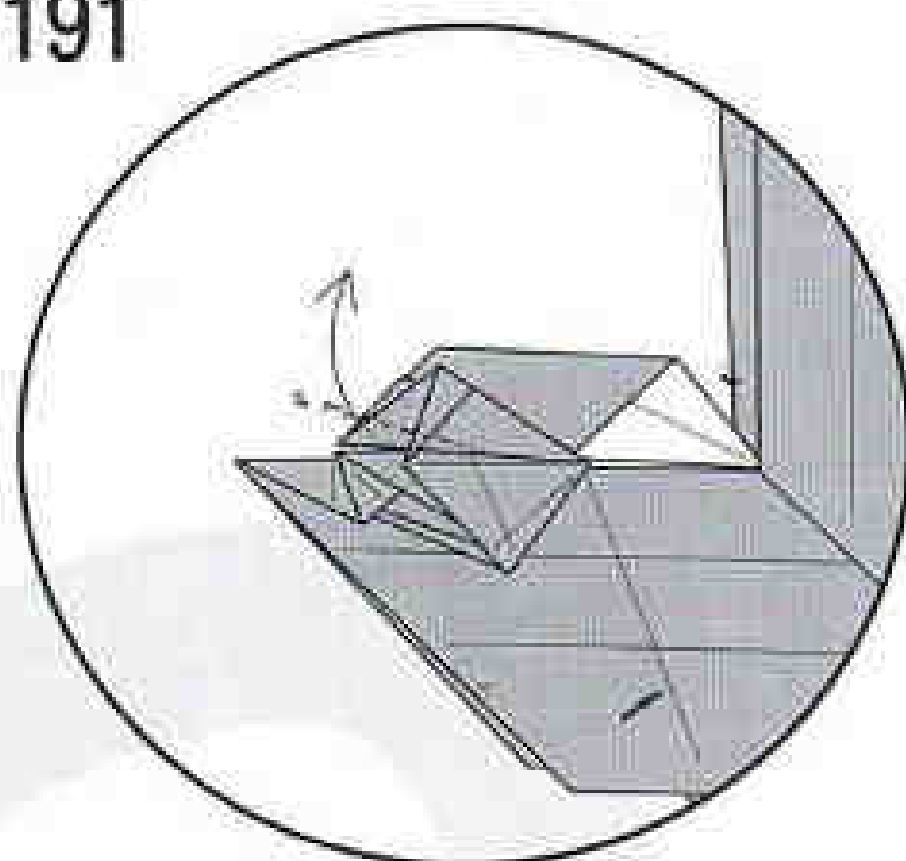

194

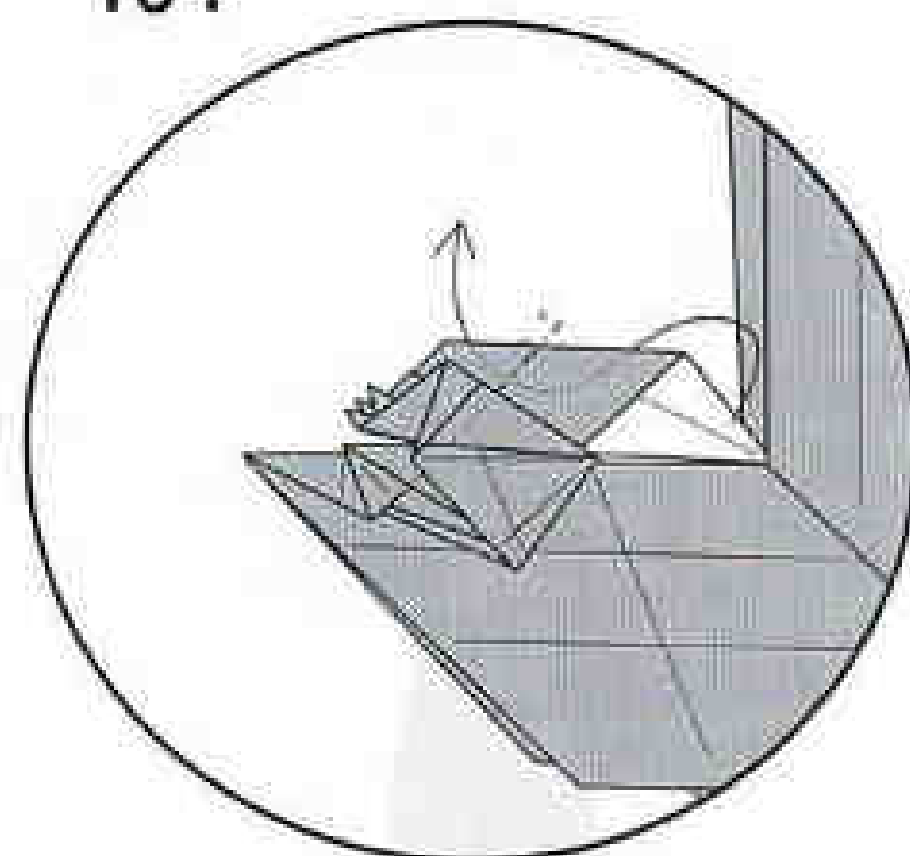

189

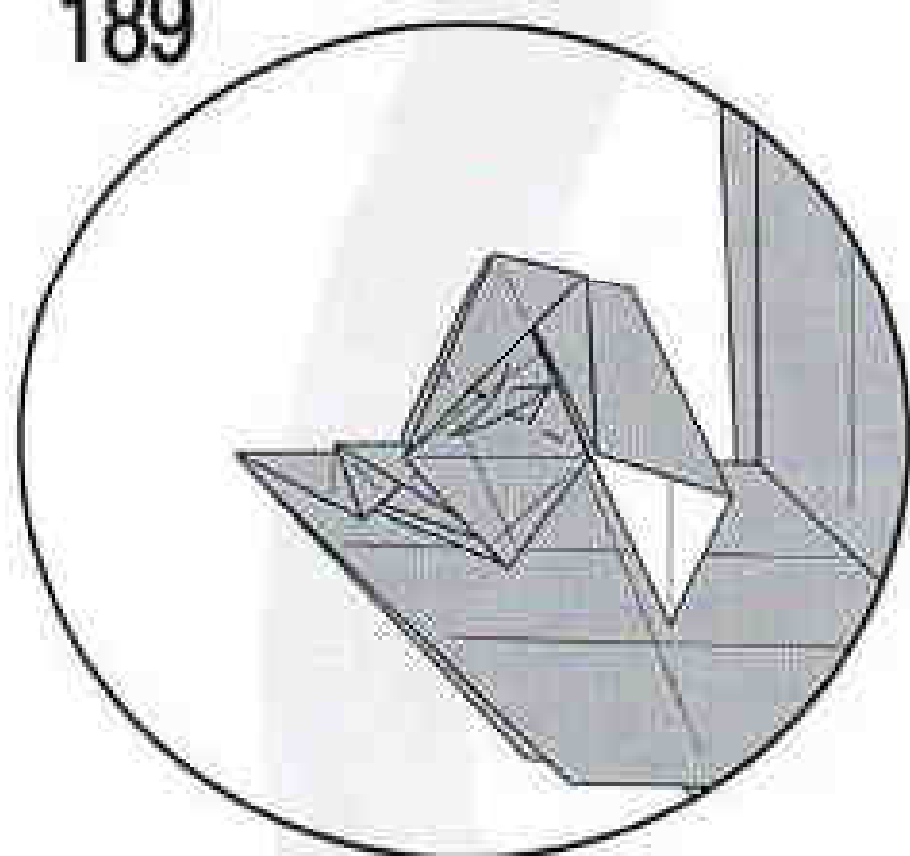

192

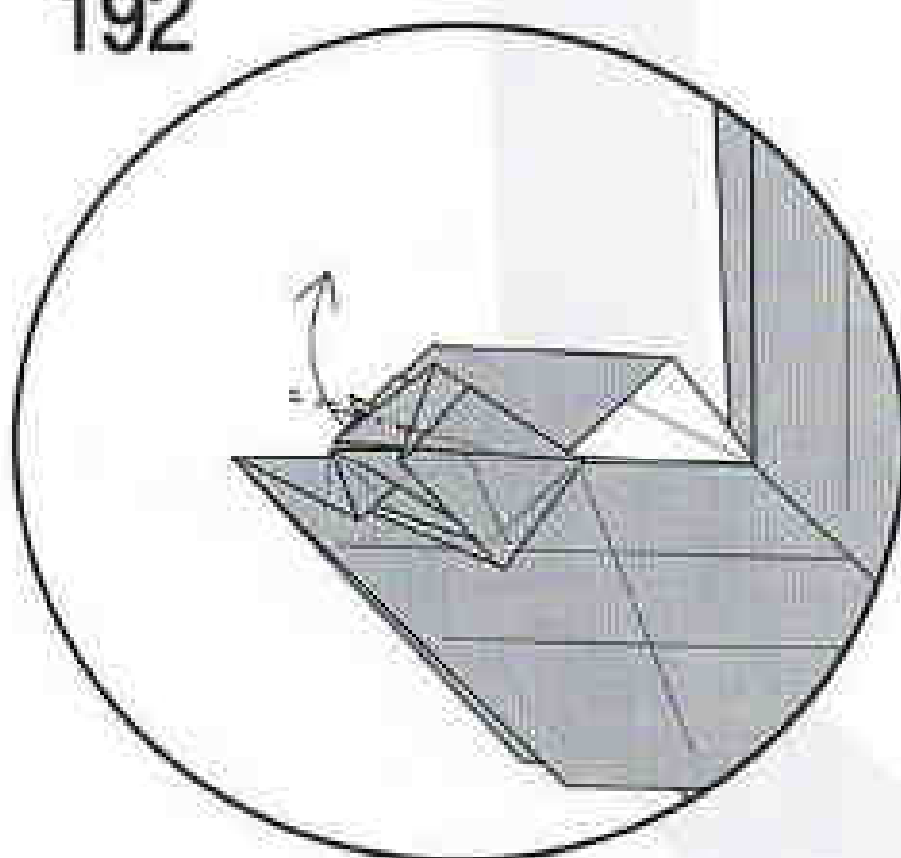

193

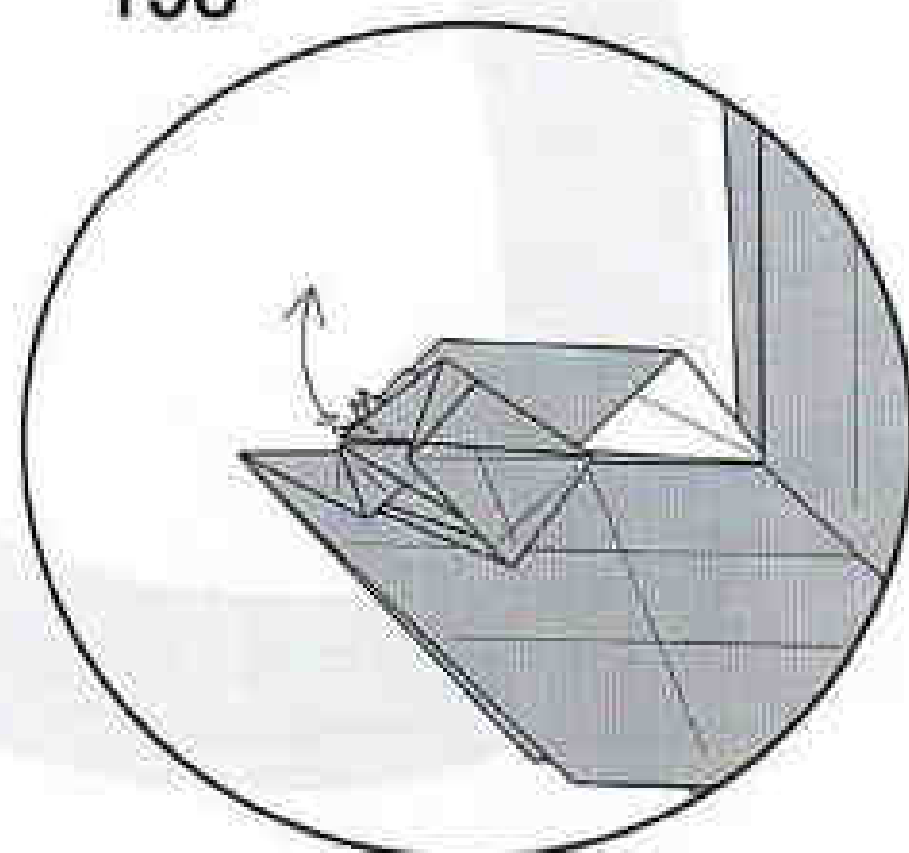

188

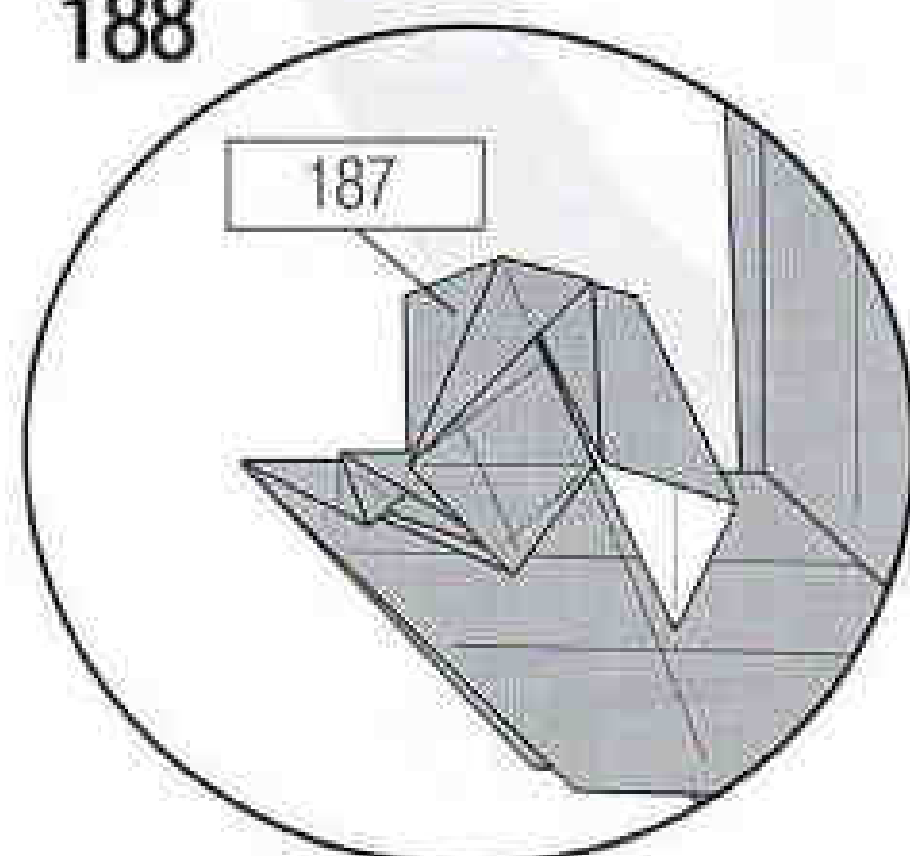

187

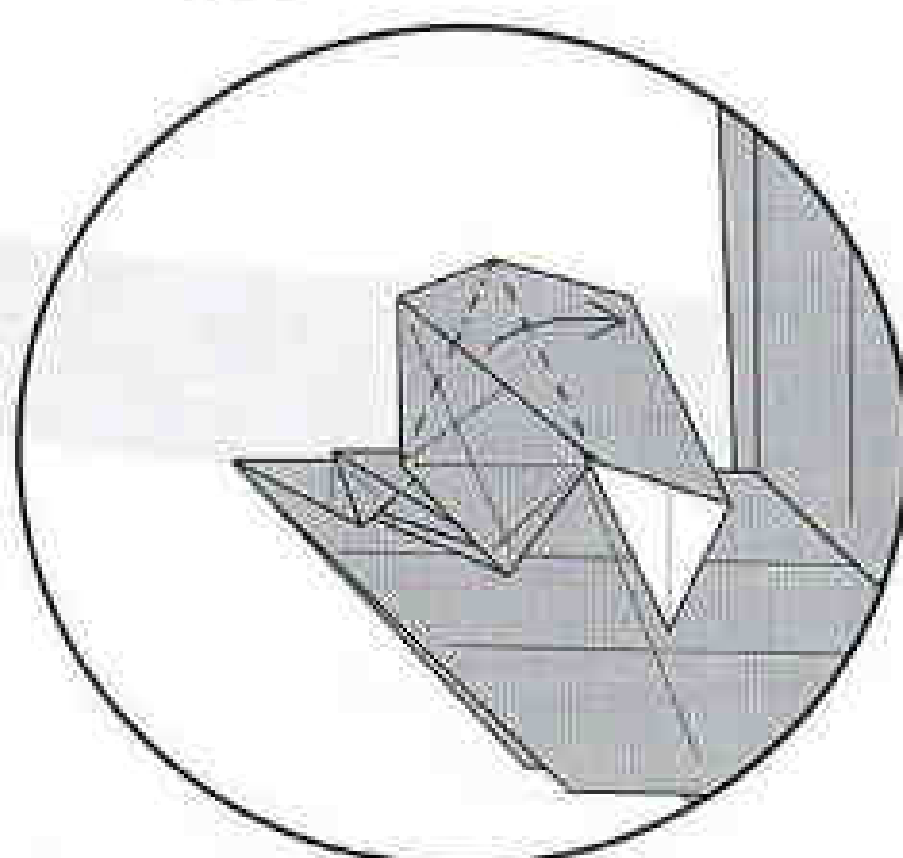

186

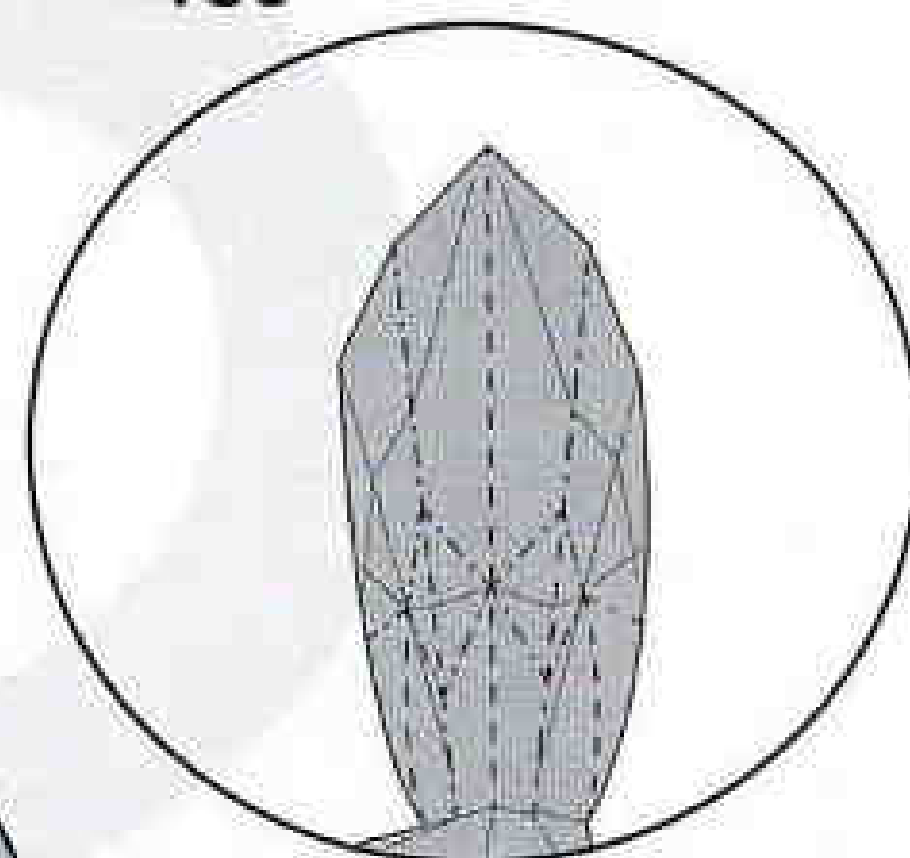

184

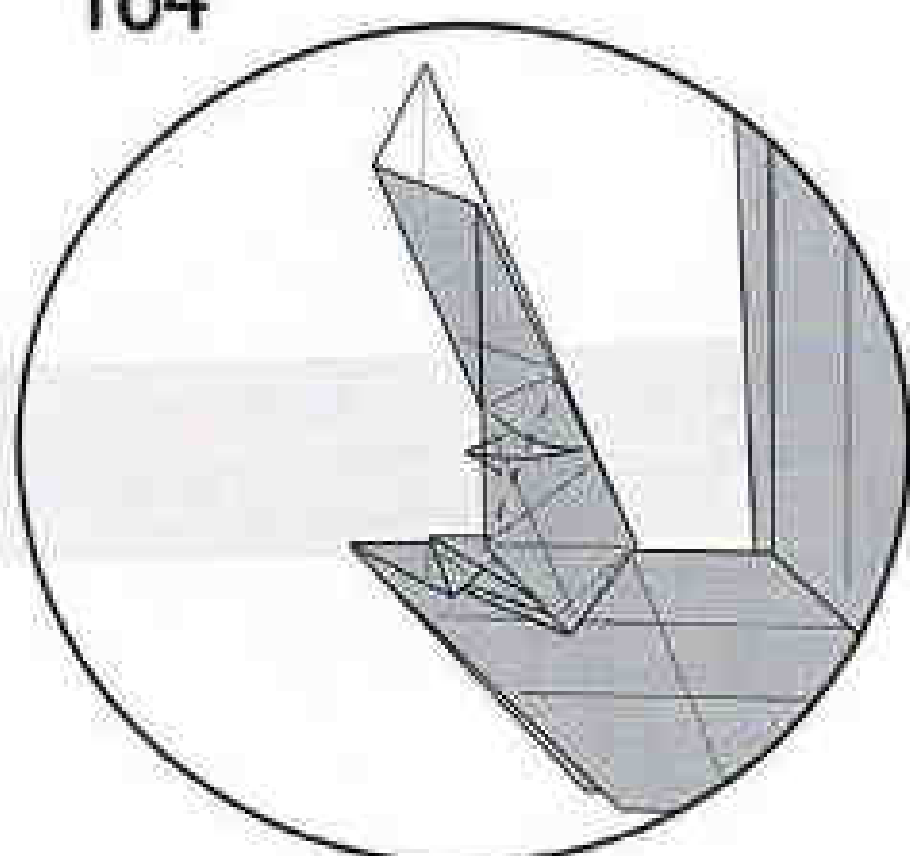

185

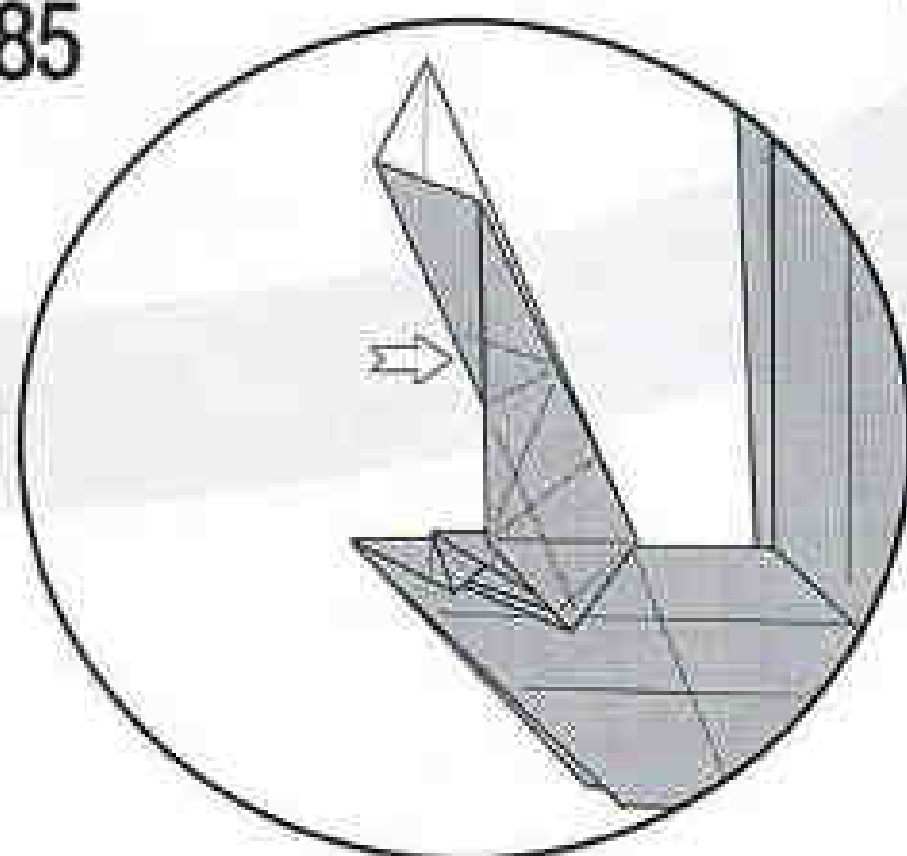

195

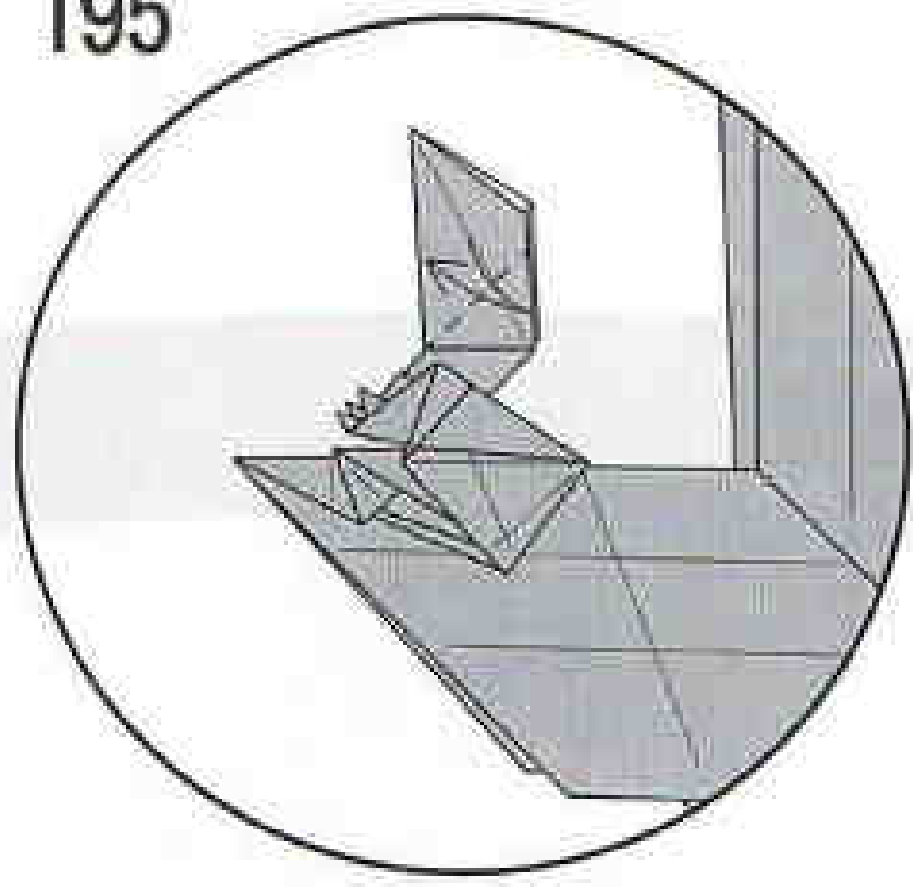

196

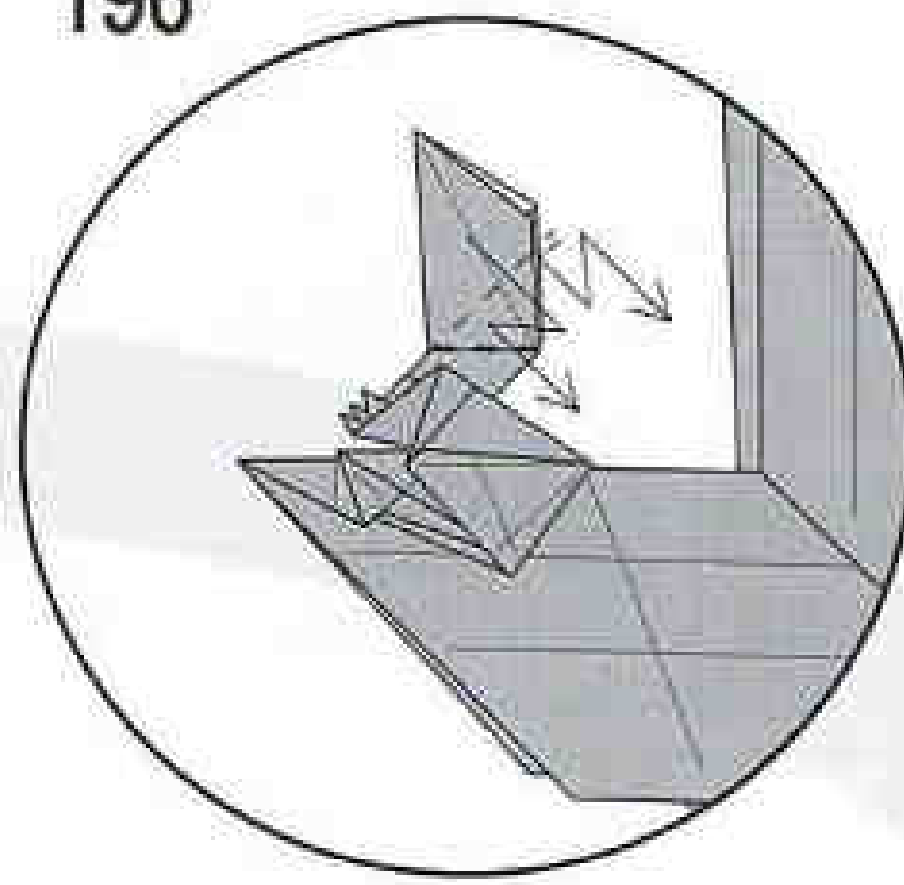

197

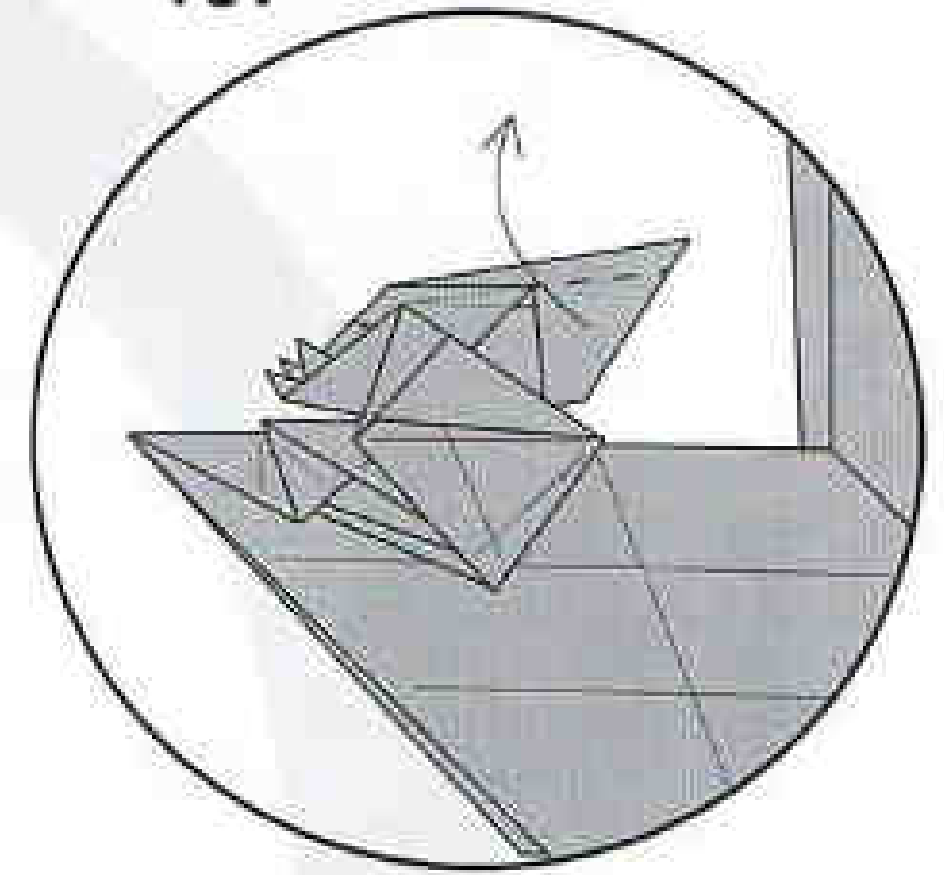

200

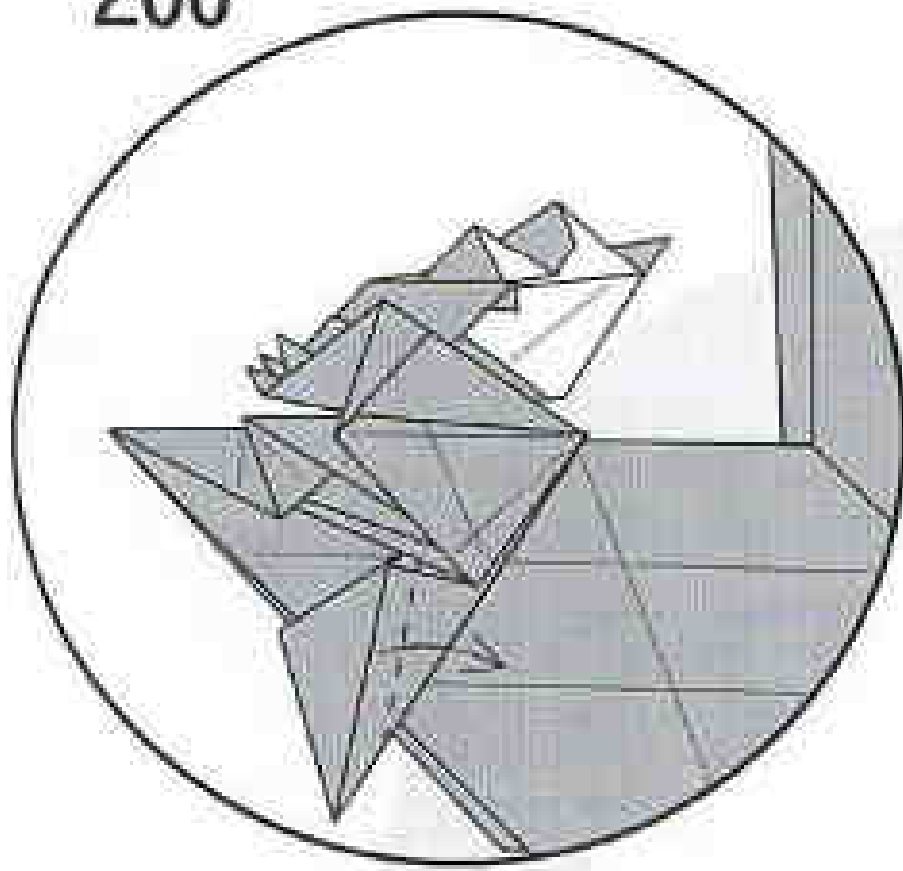

199

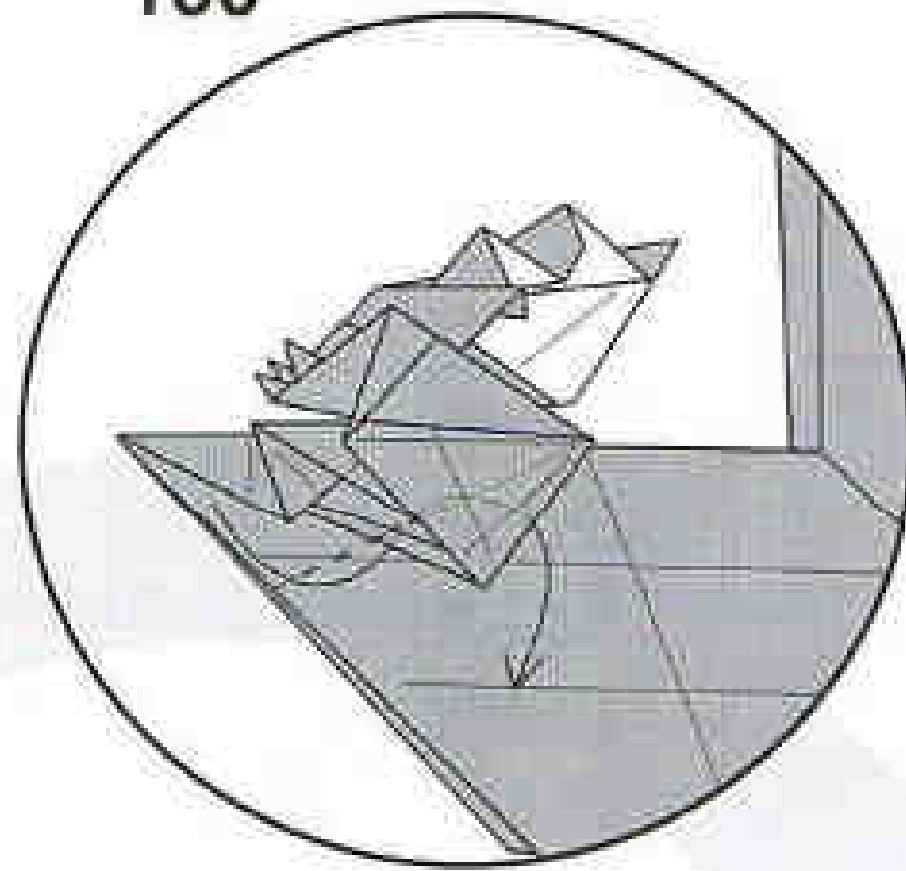

198

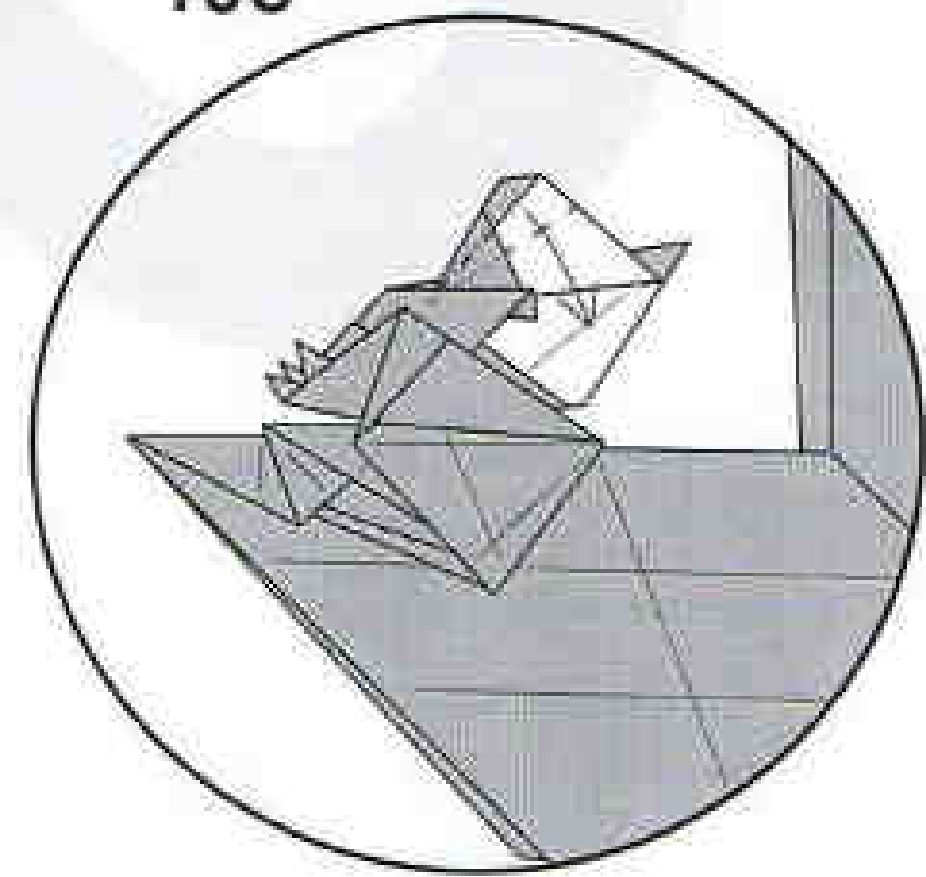

201

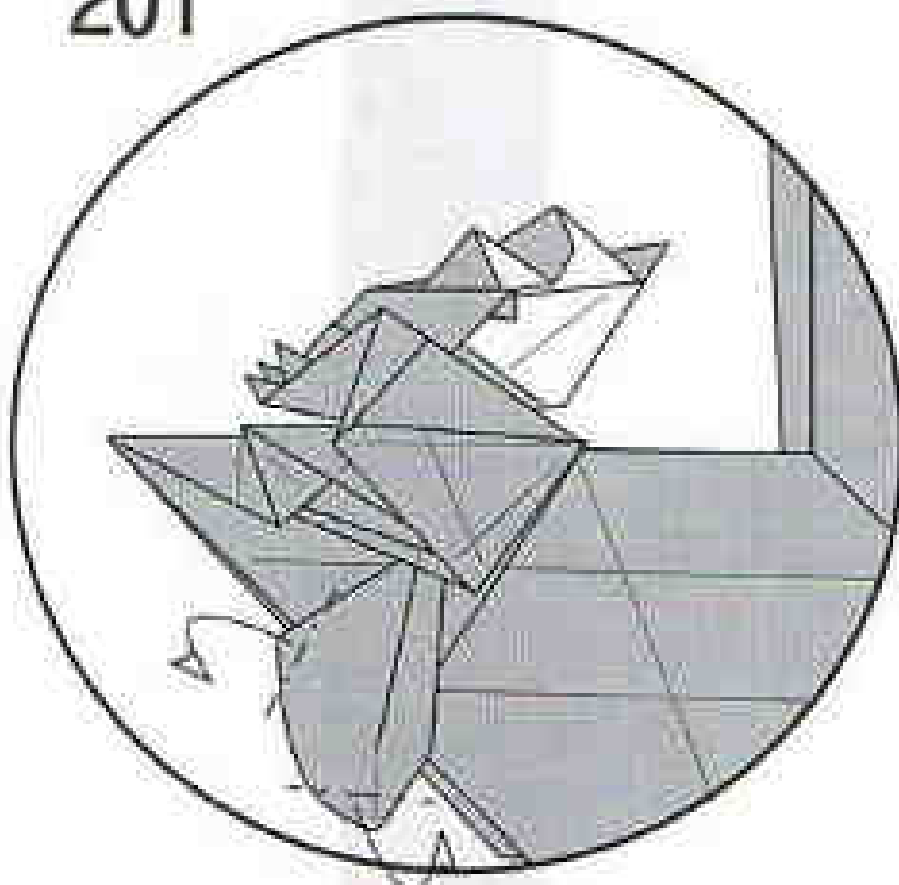

203

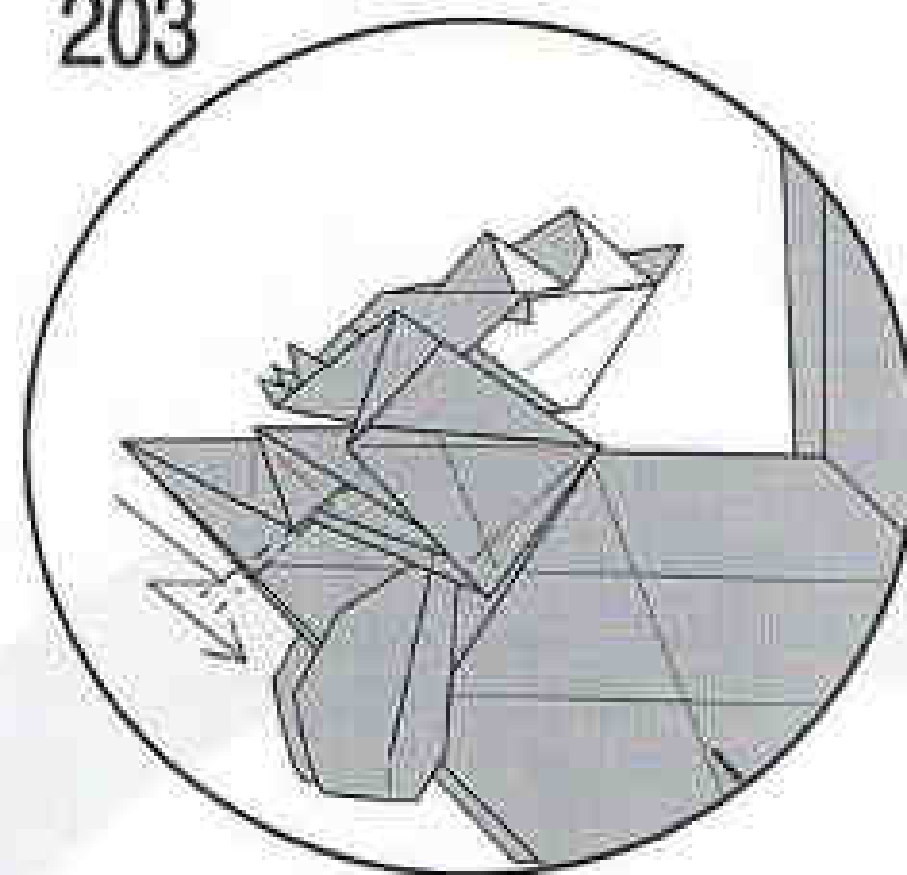

204

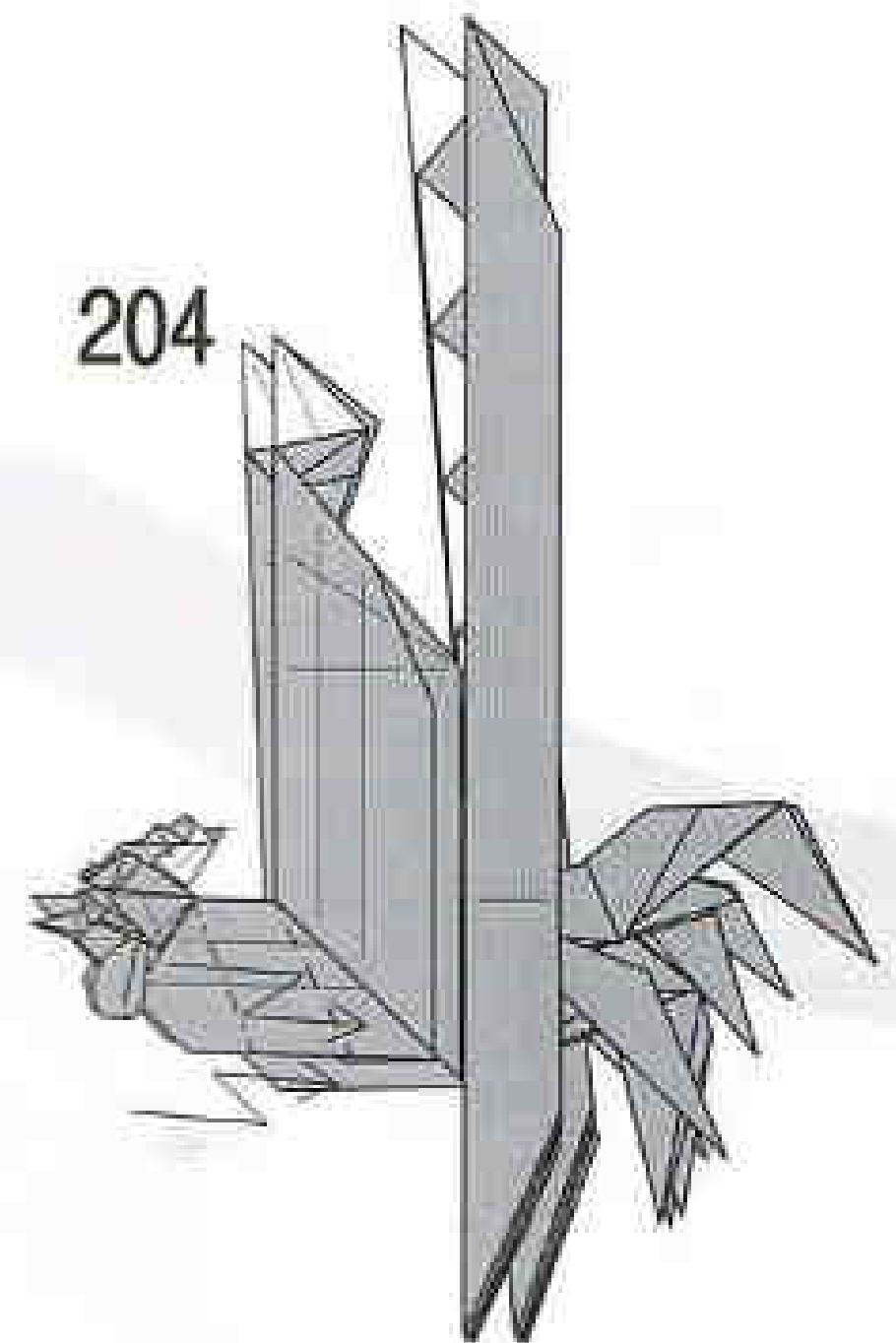

202

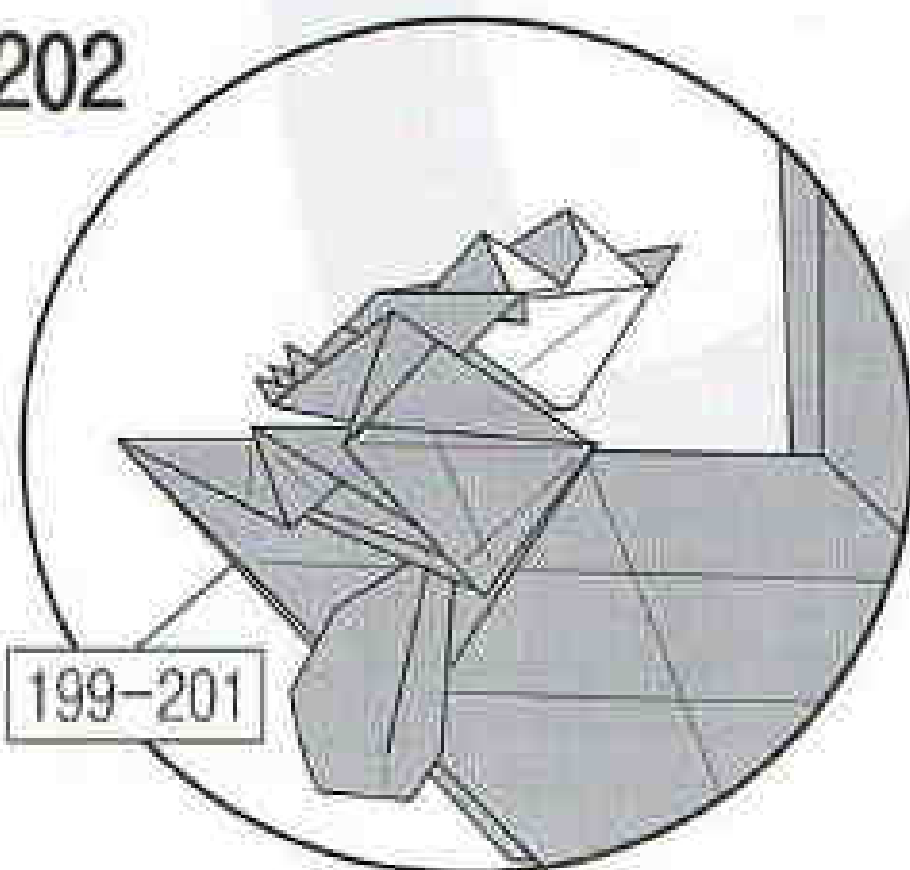

199-201

211

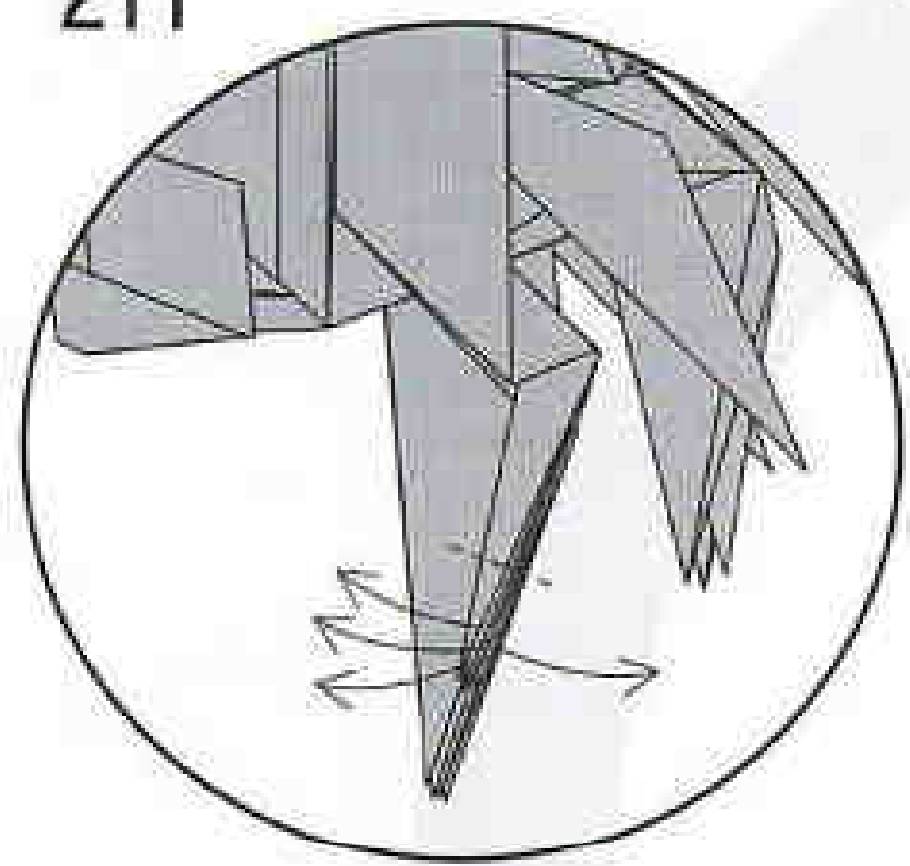

212

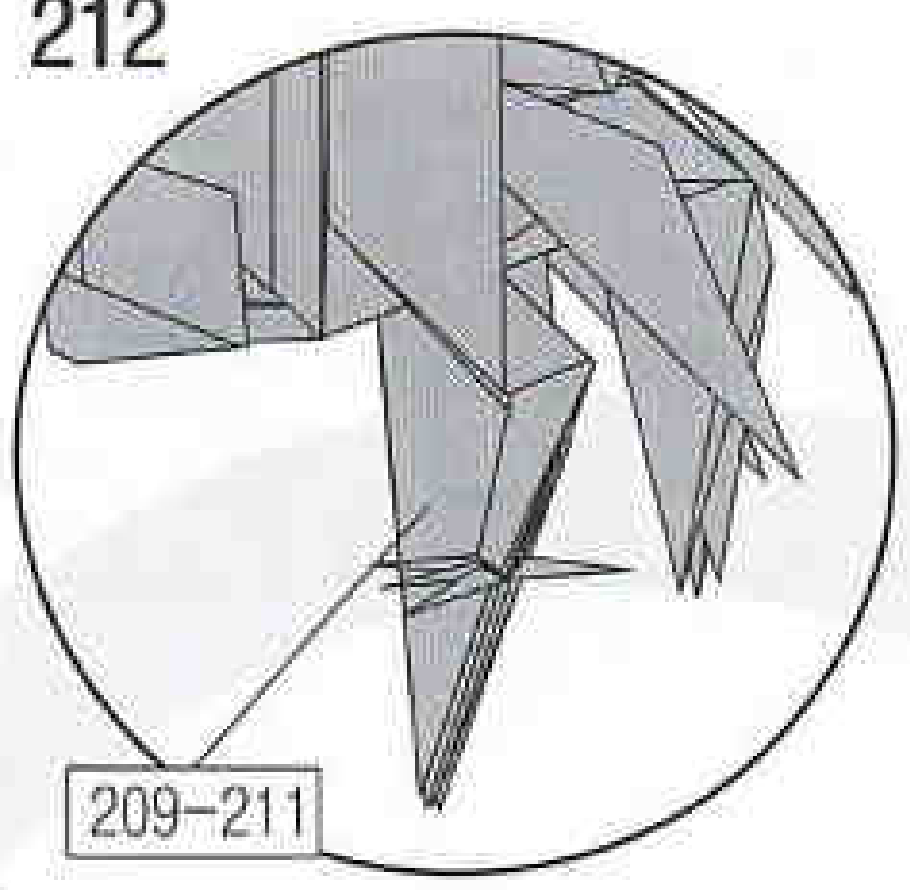

213

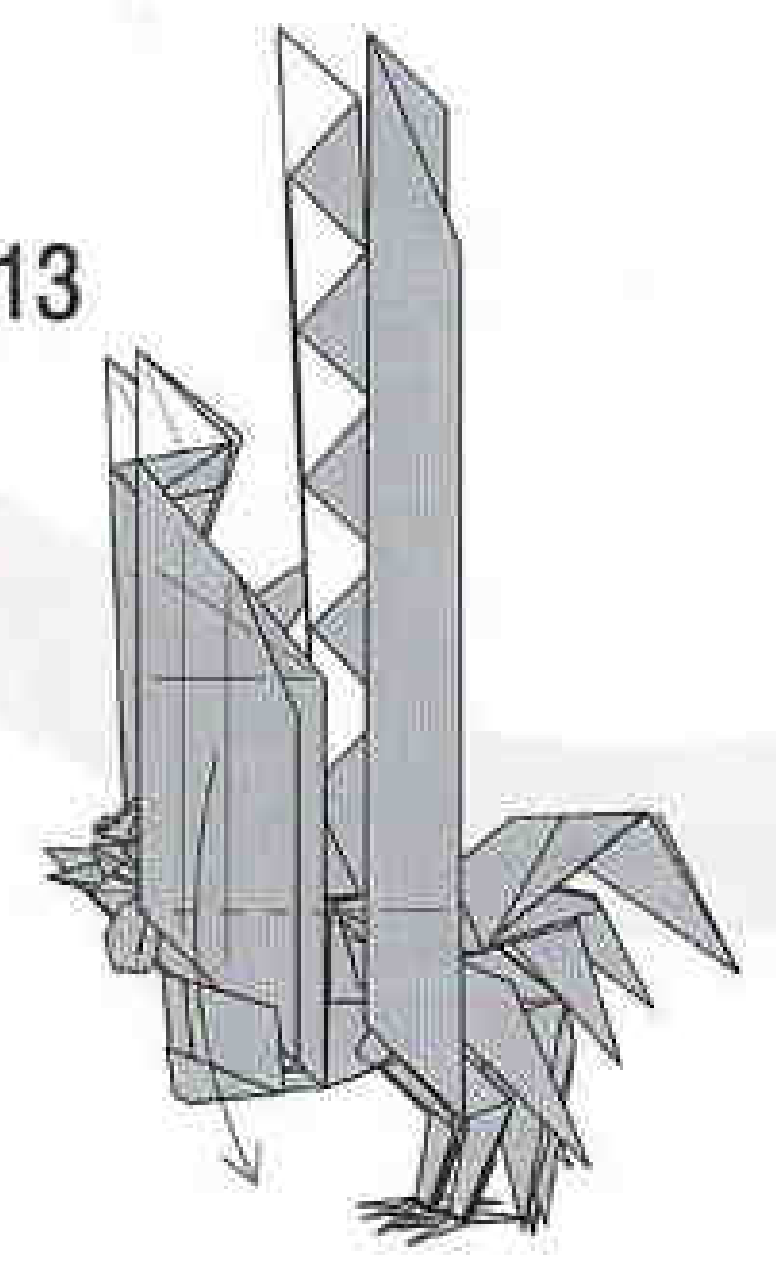

210

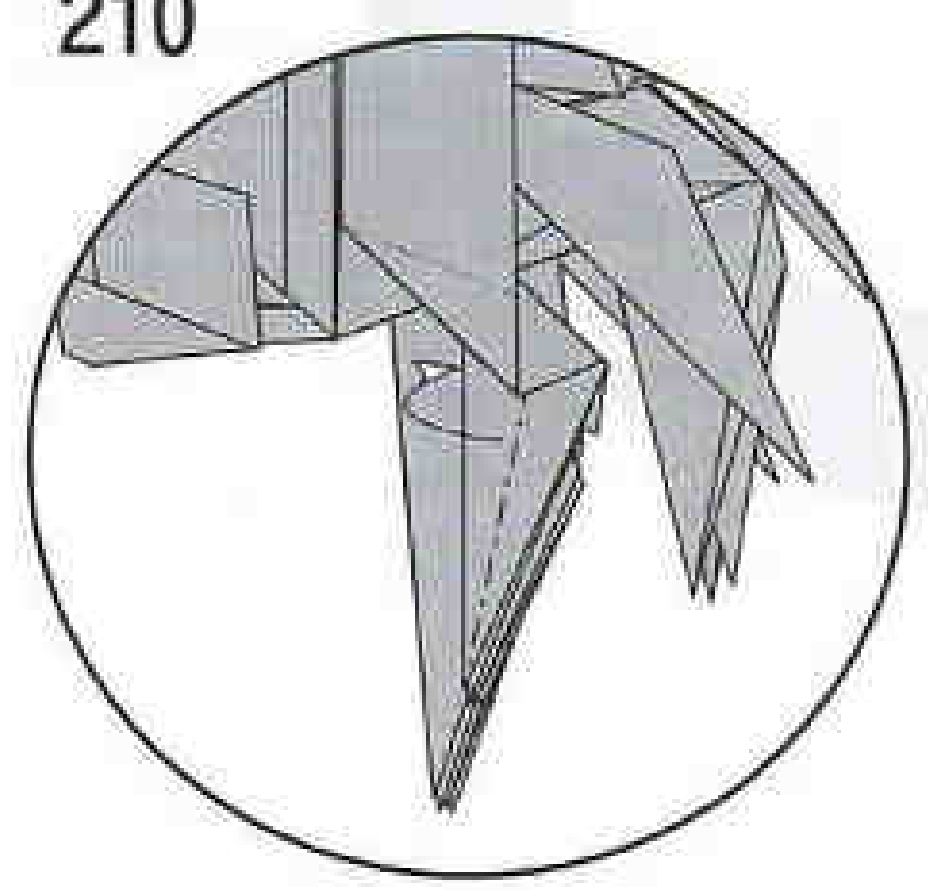

209

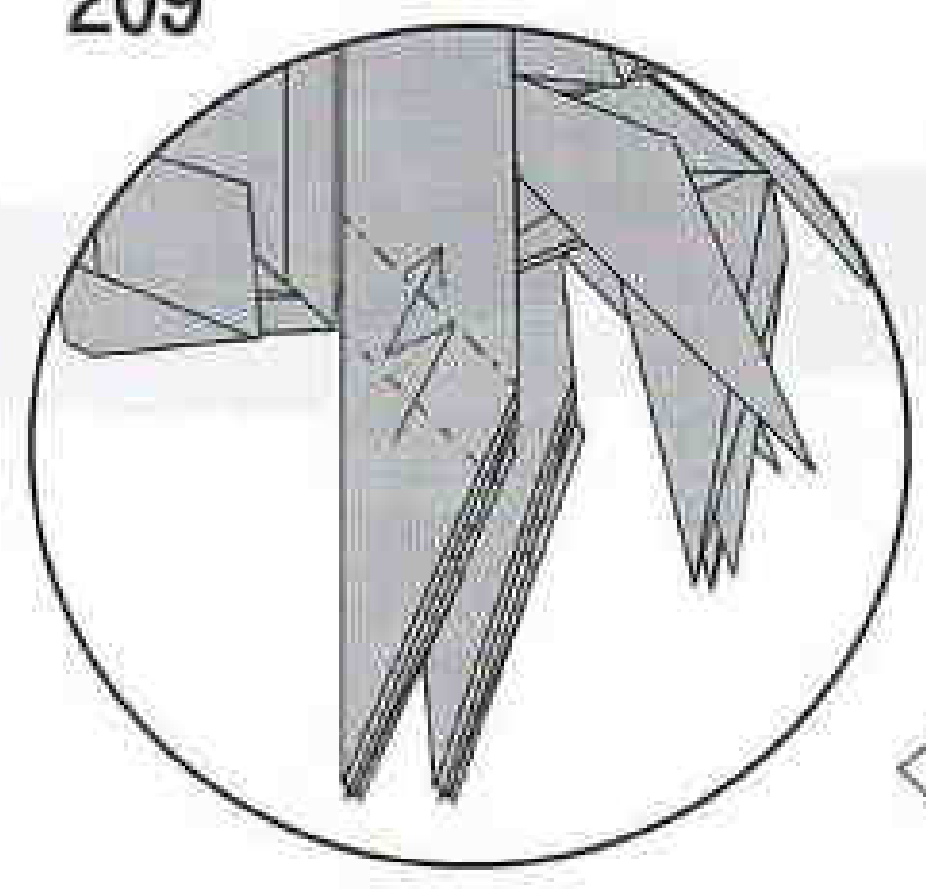

208

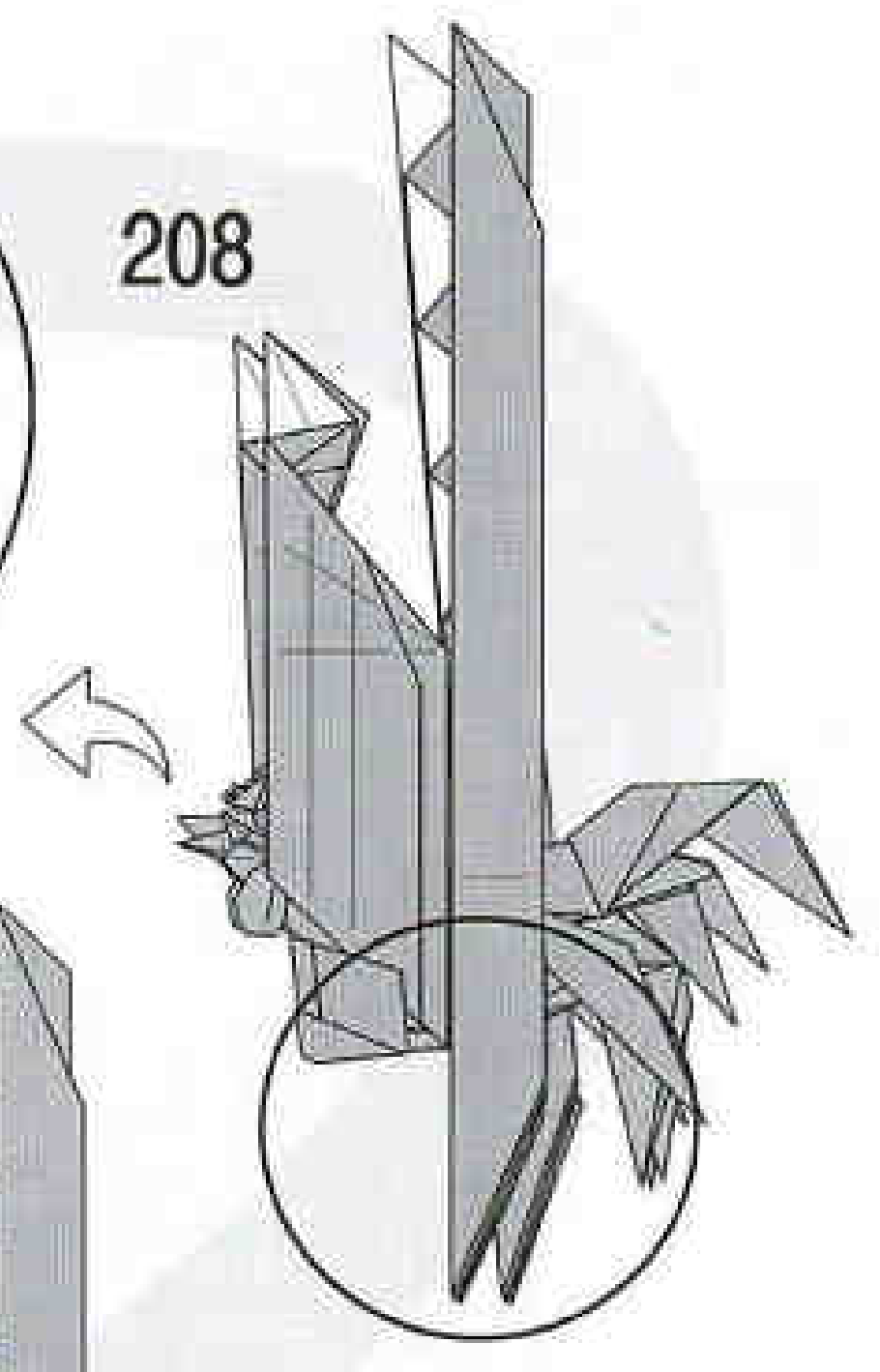

205

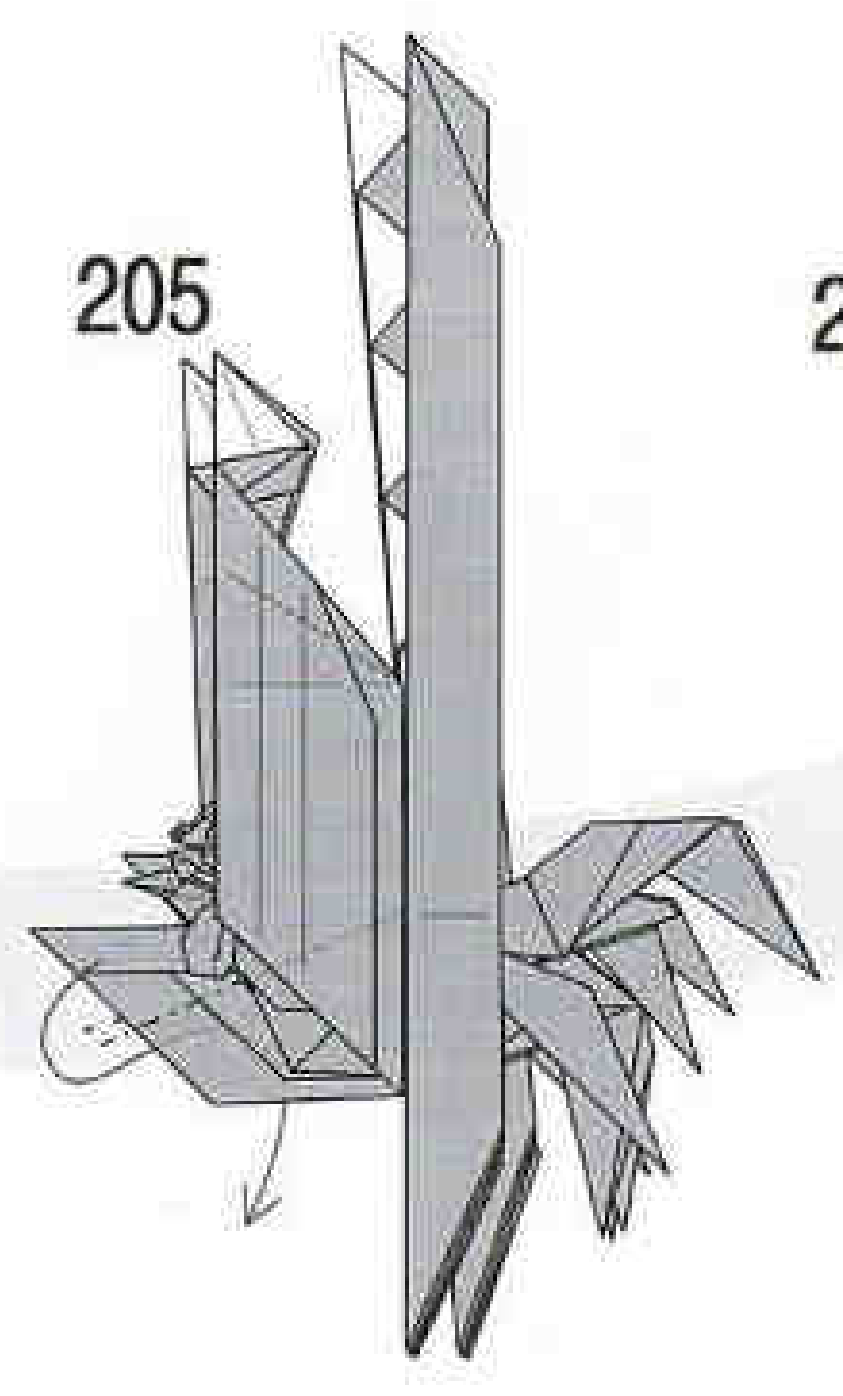

206

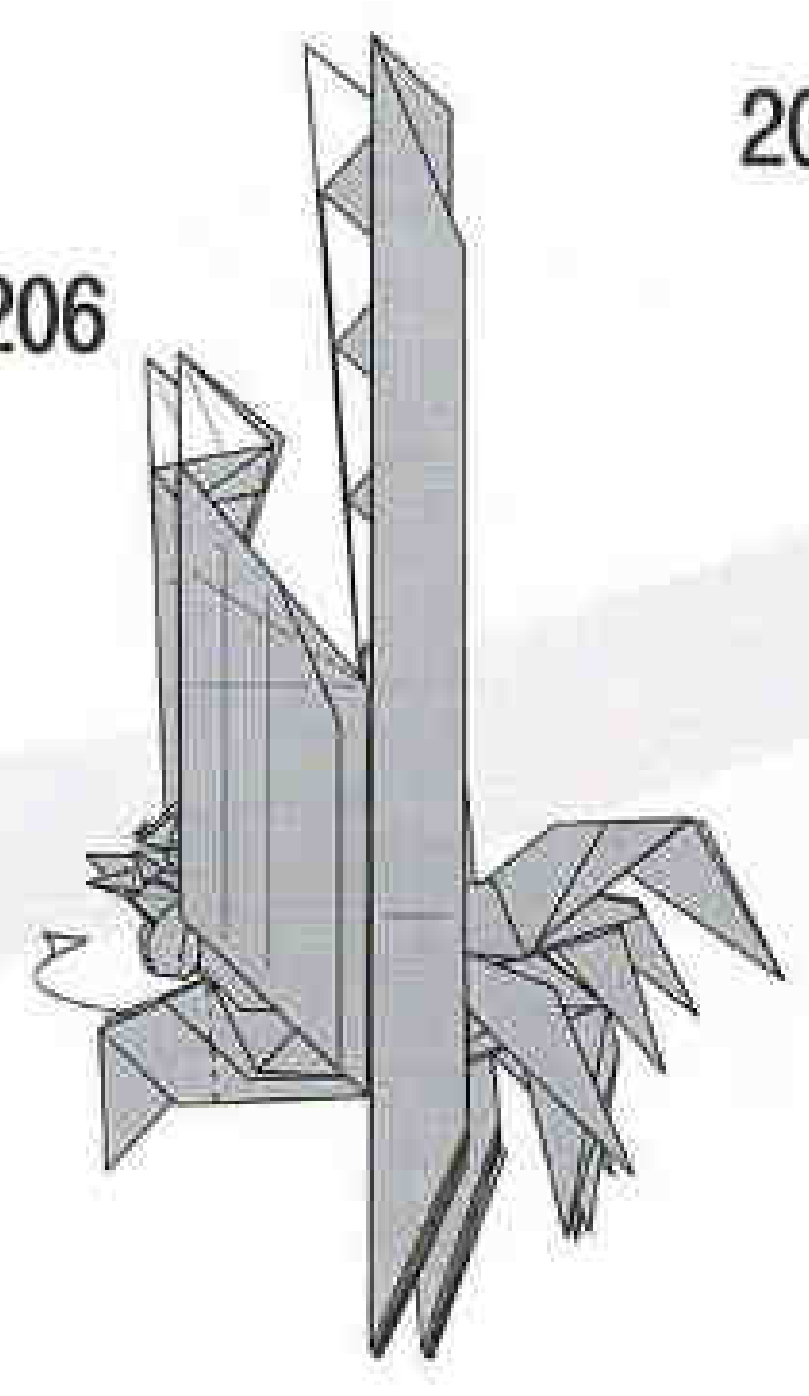

207

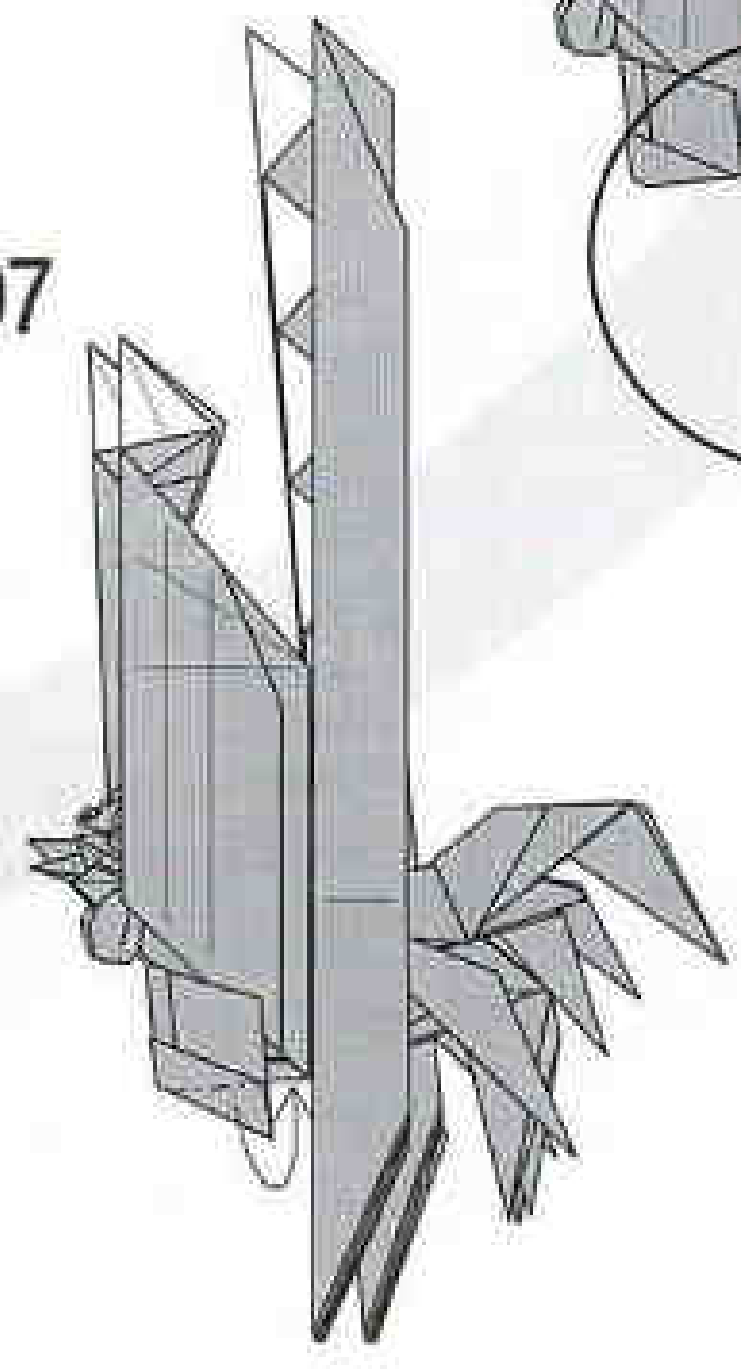

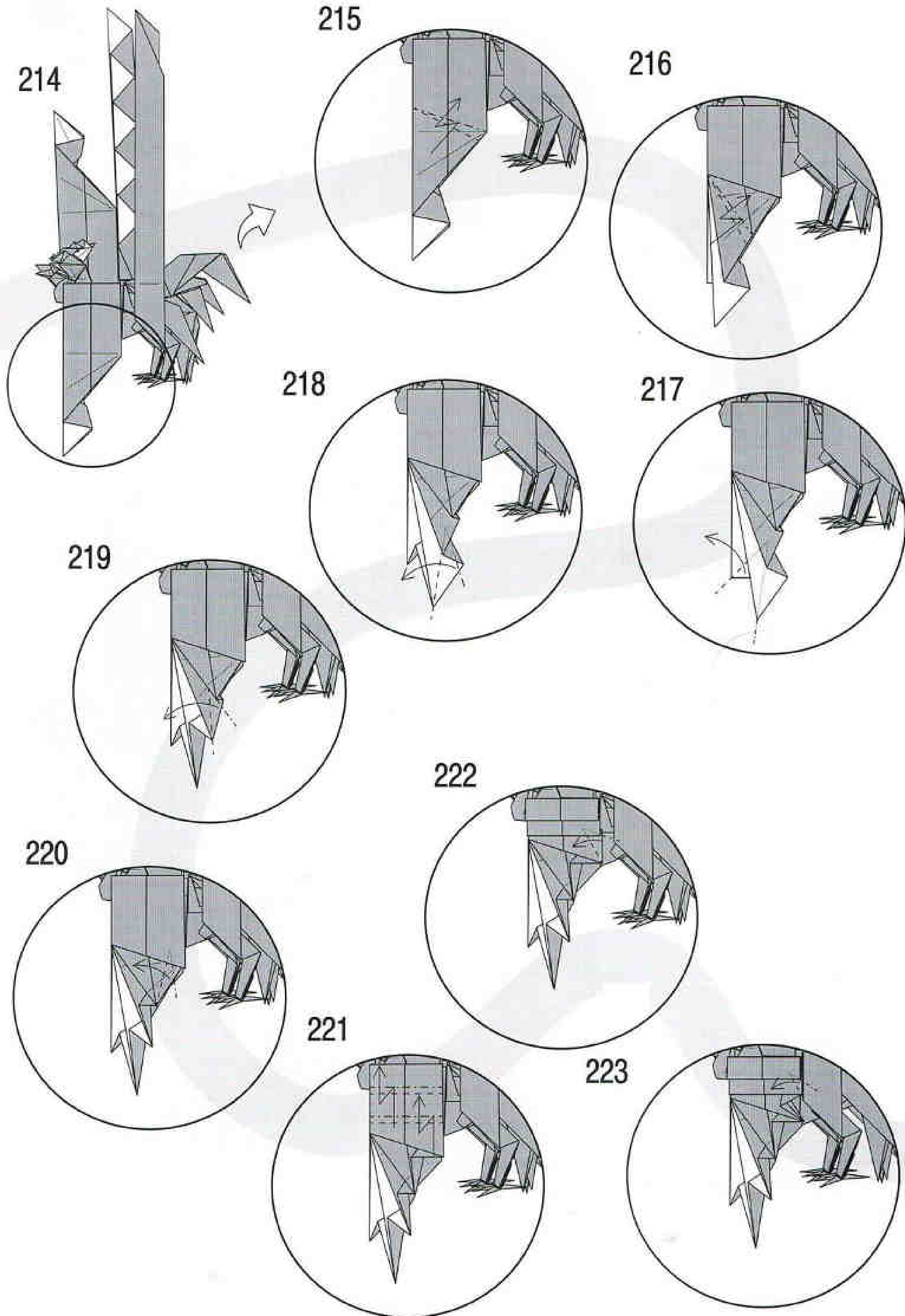

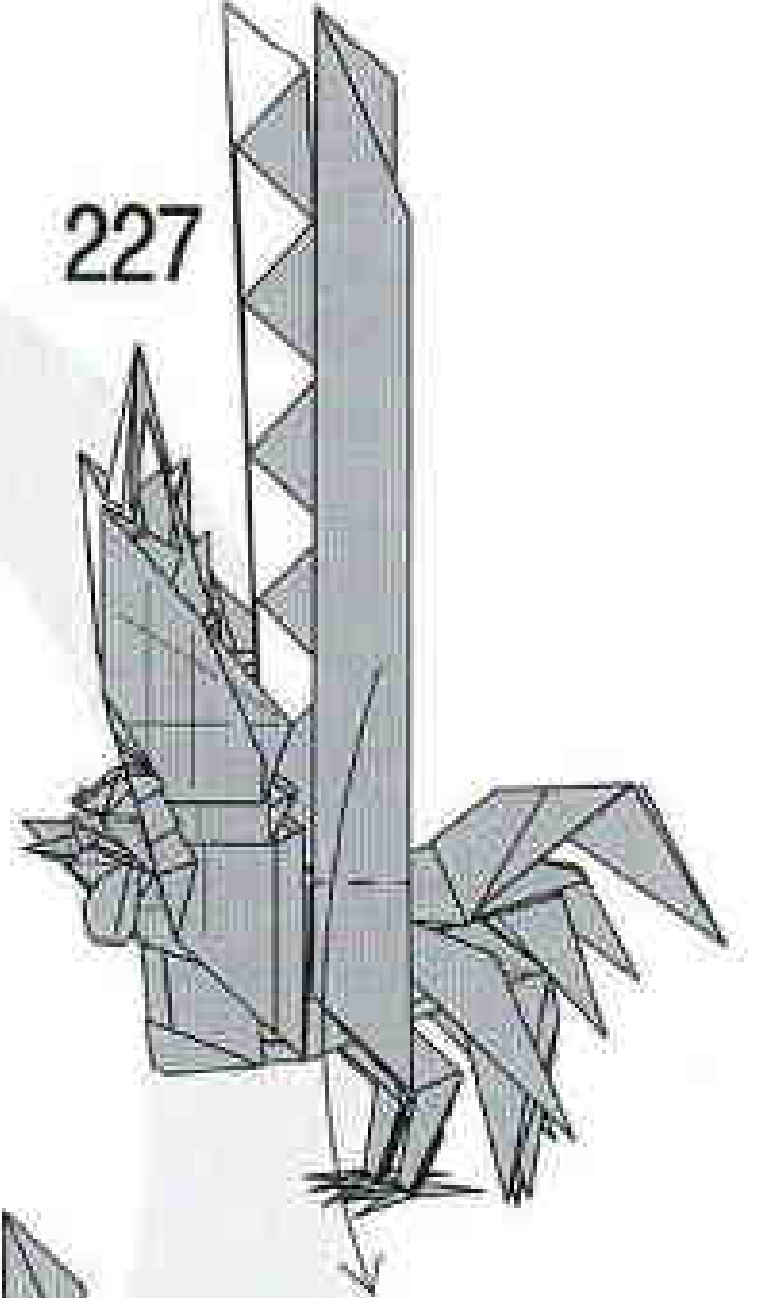
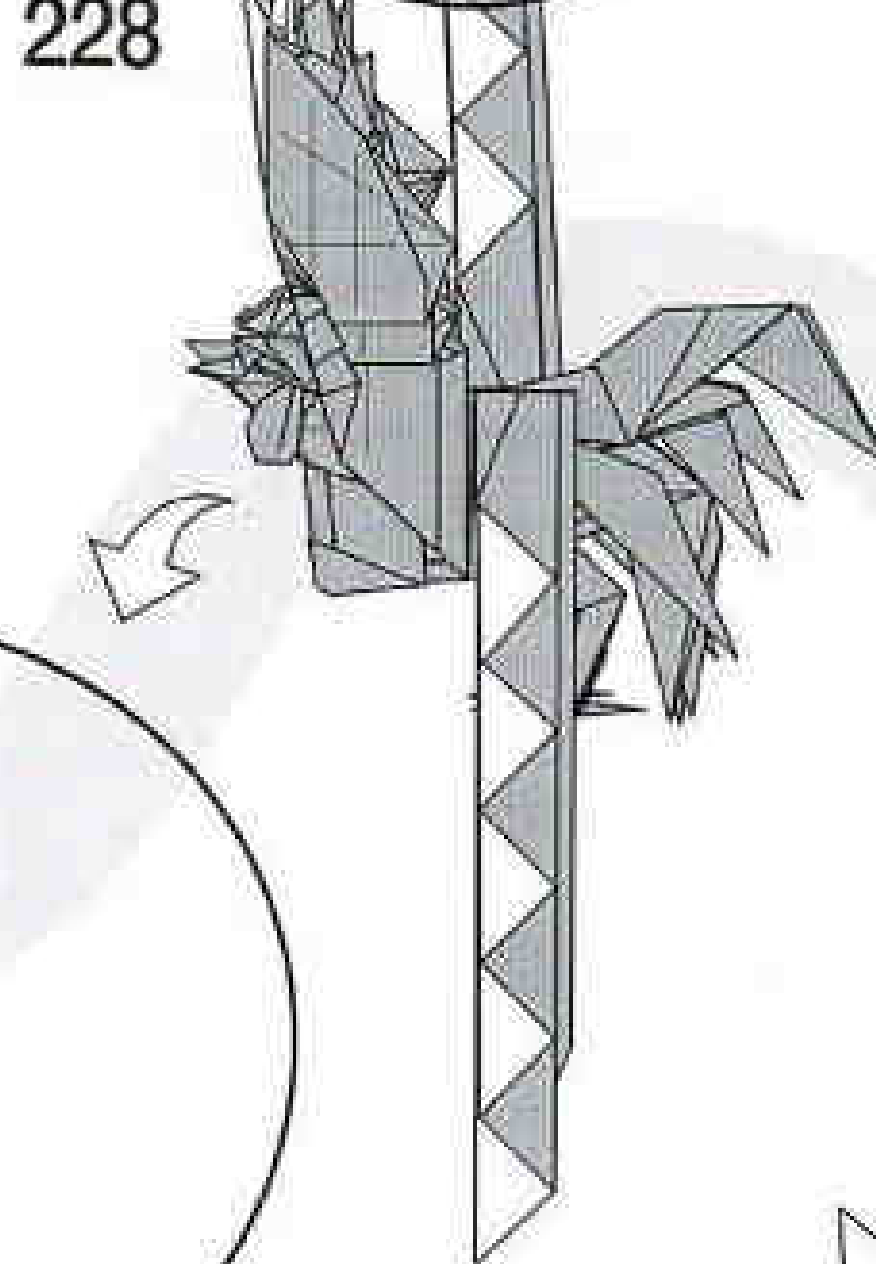
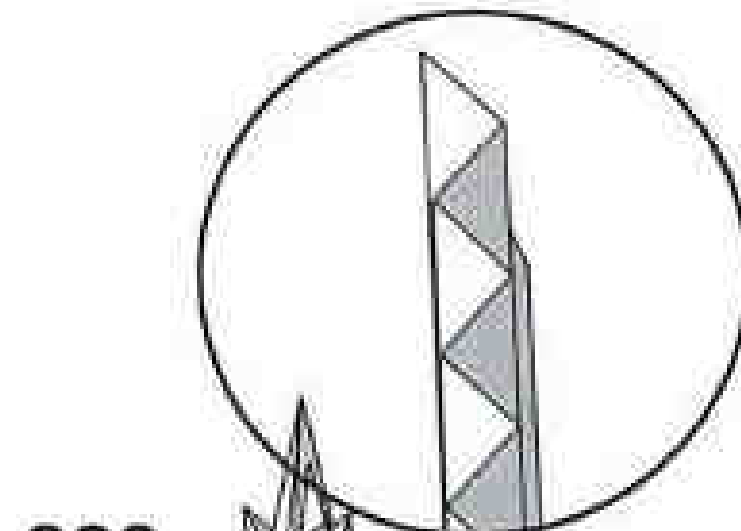
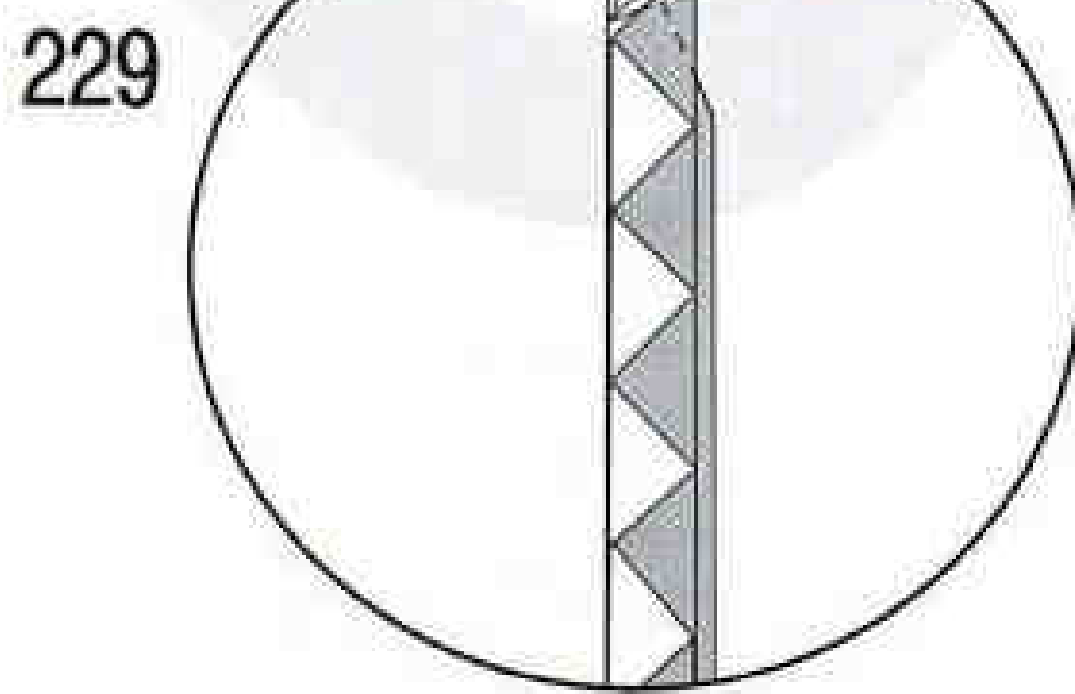
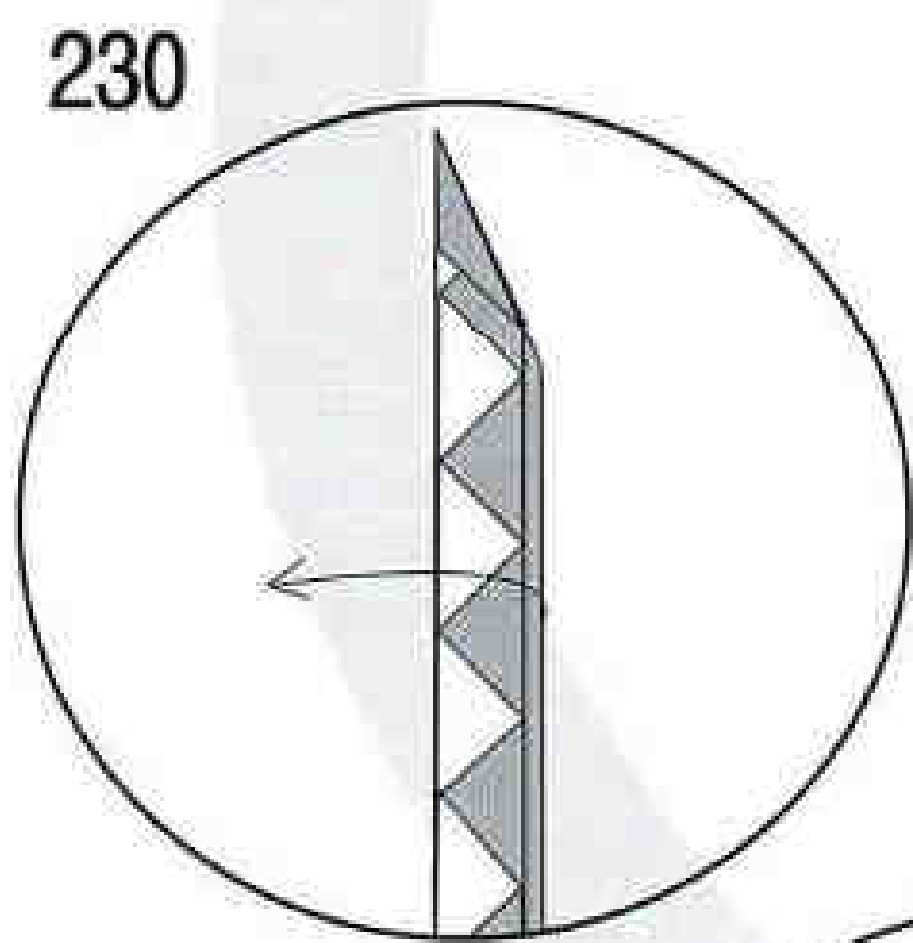
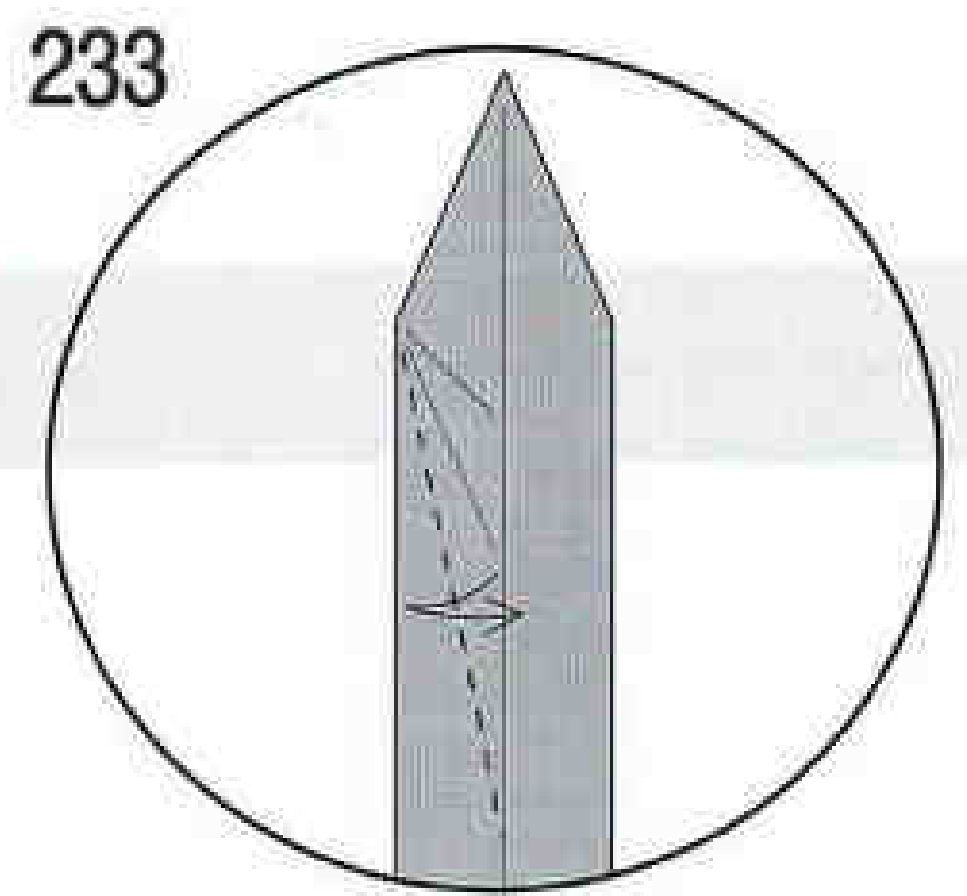
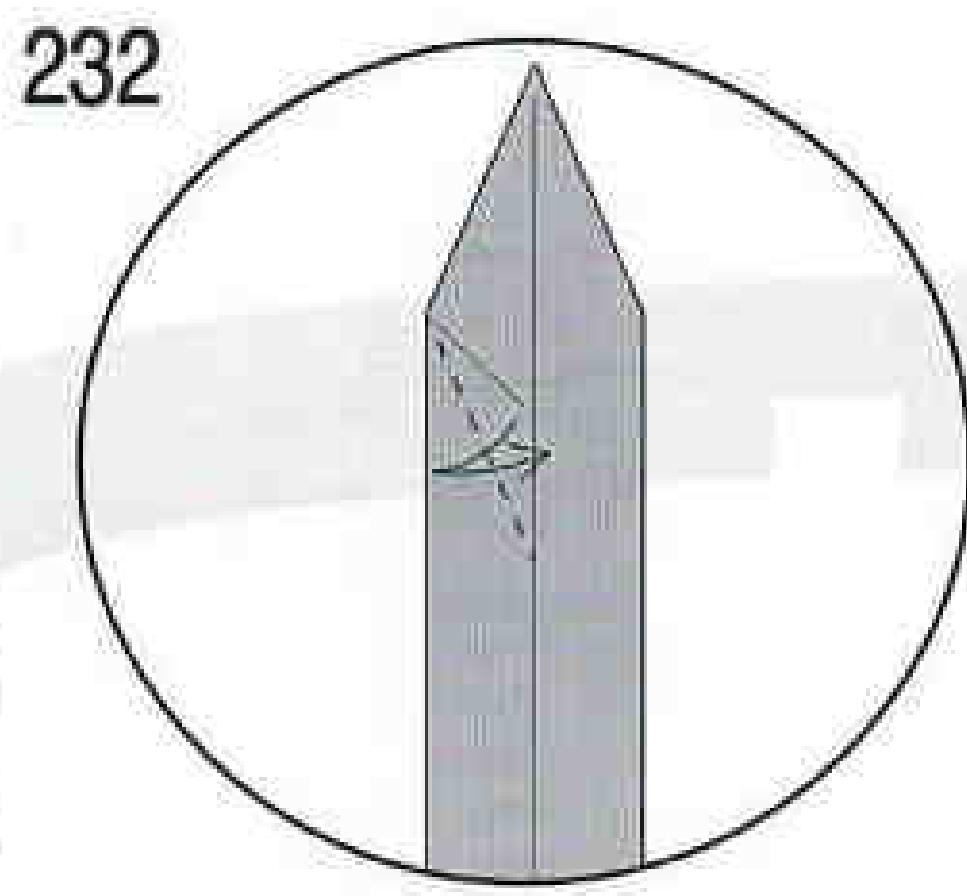
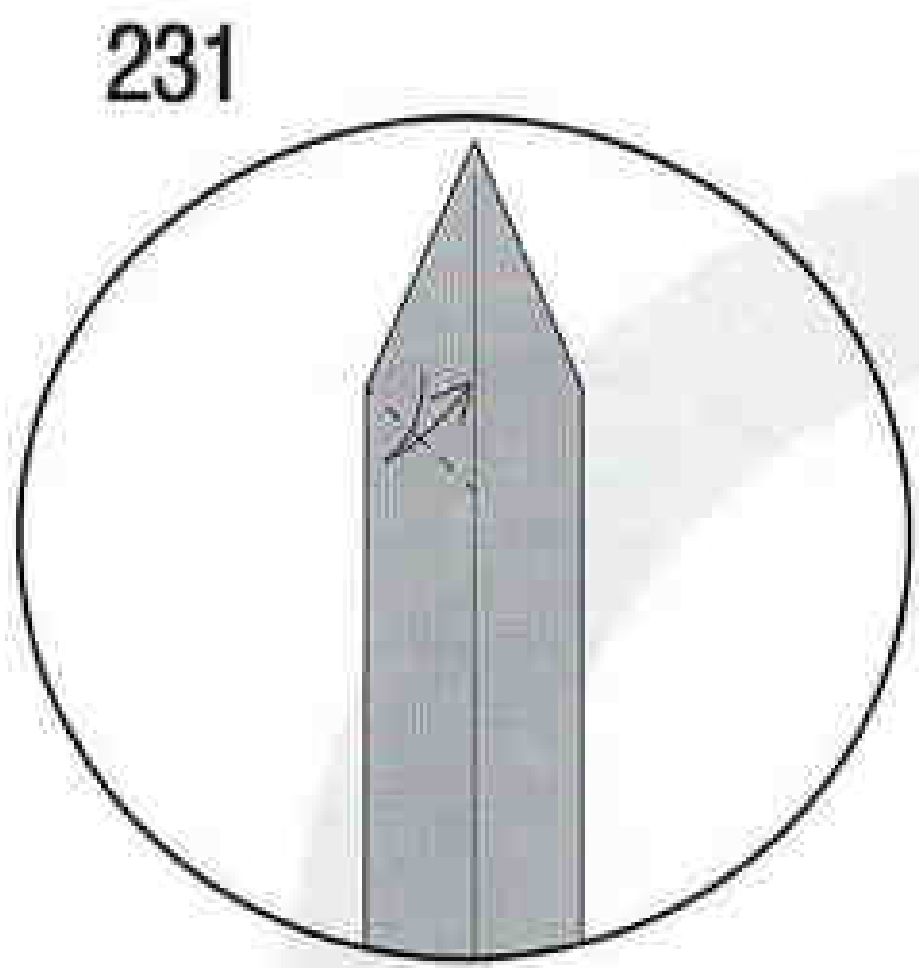

213-225

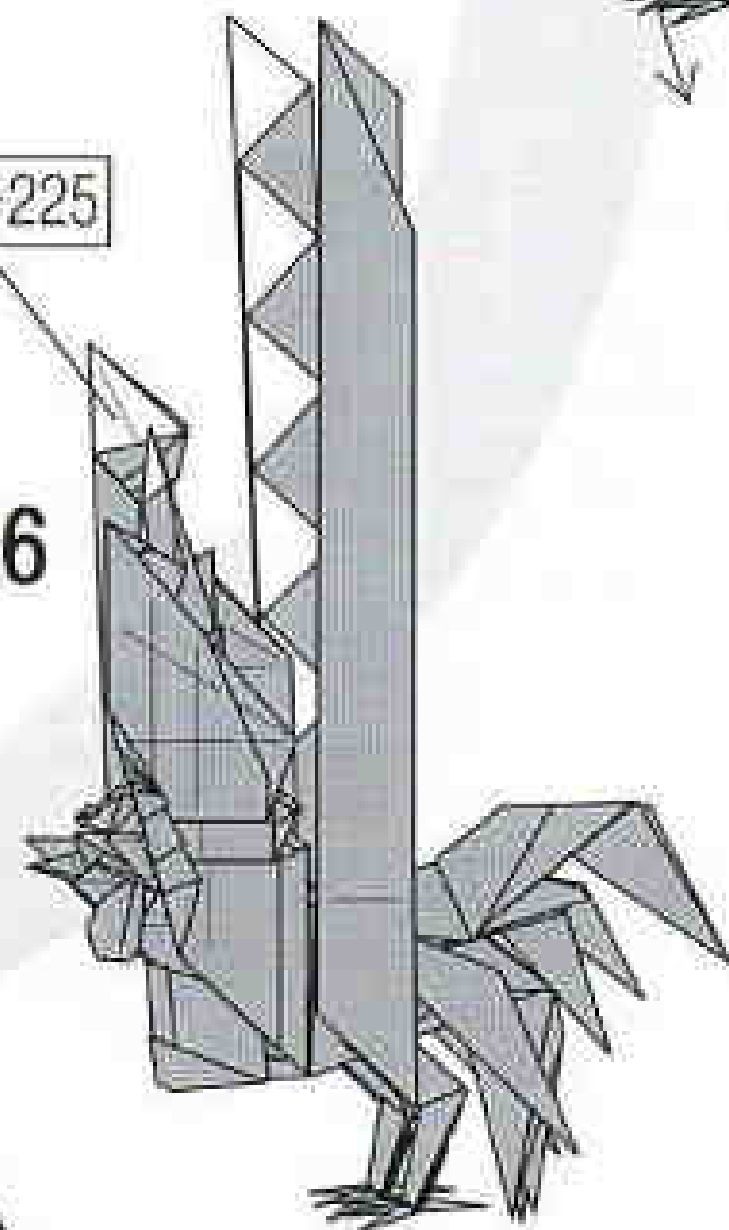
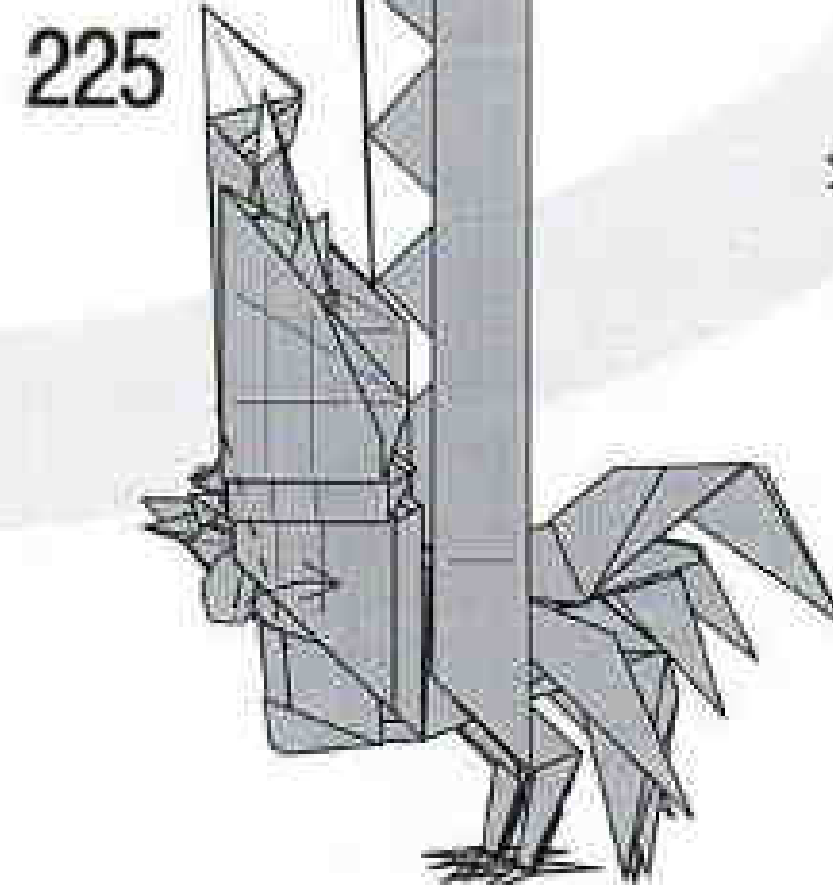
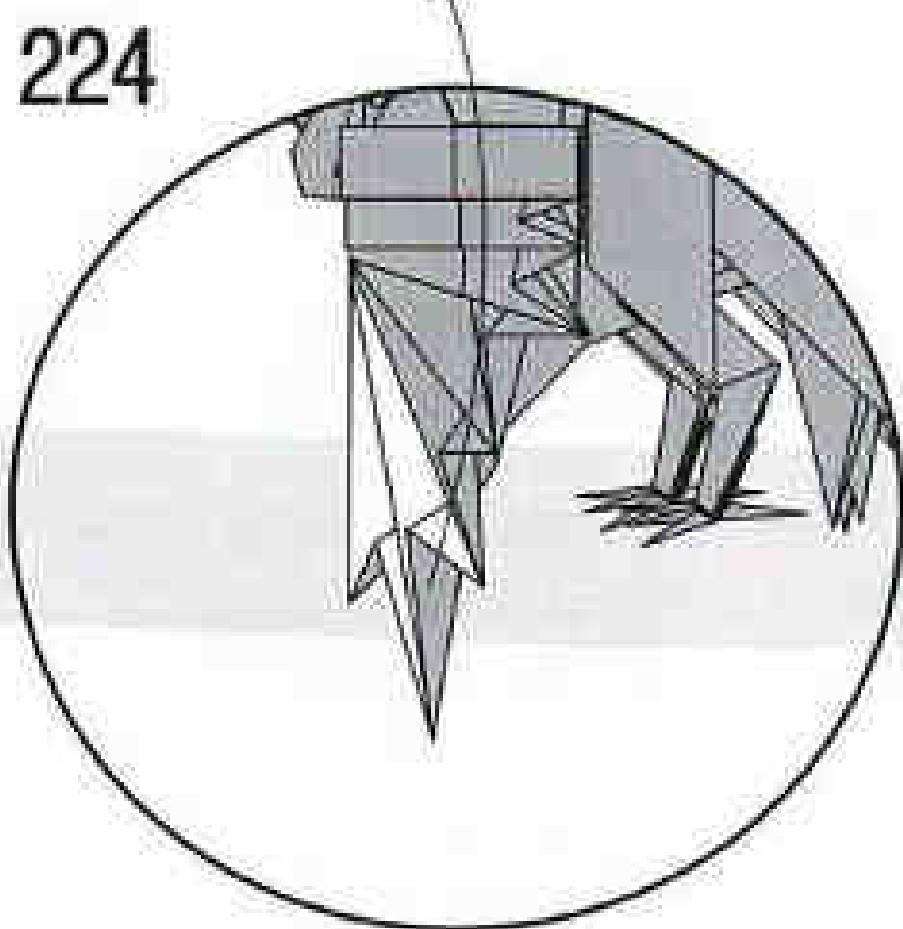

234

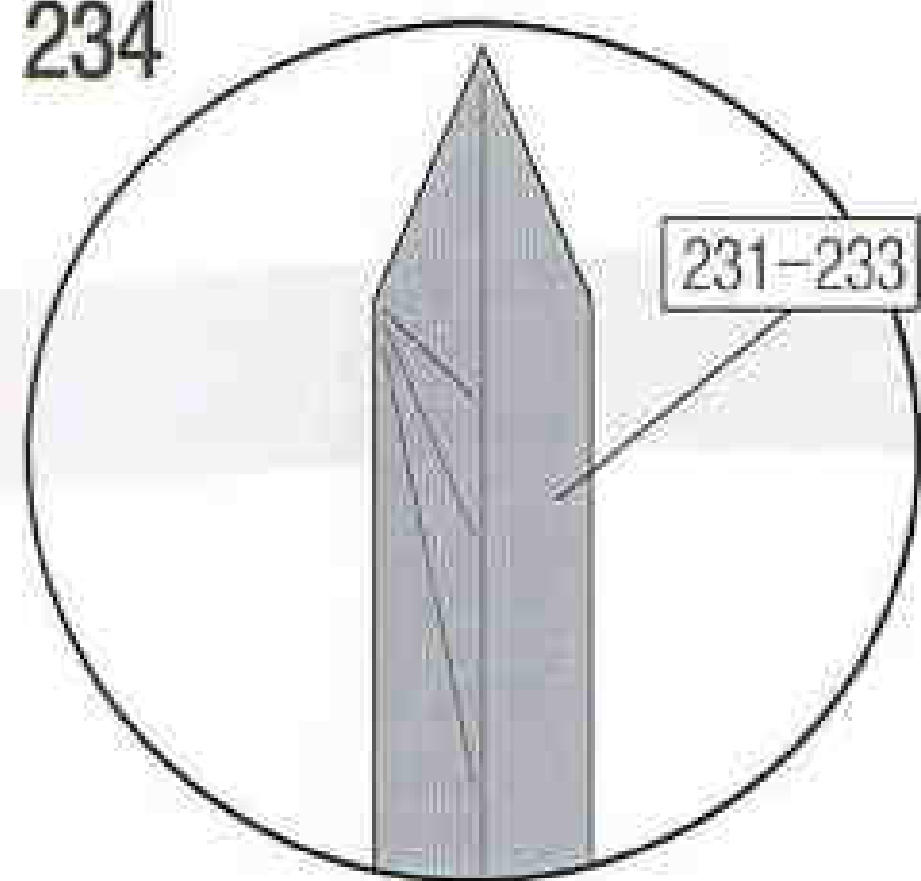

235

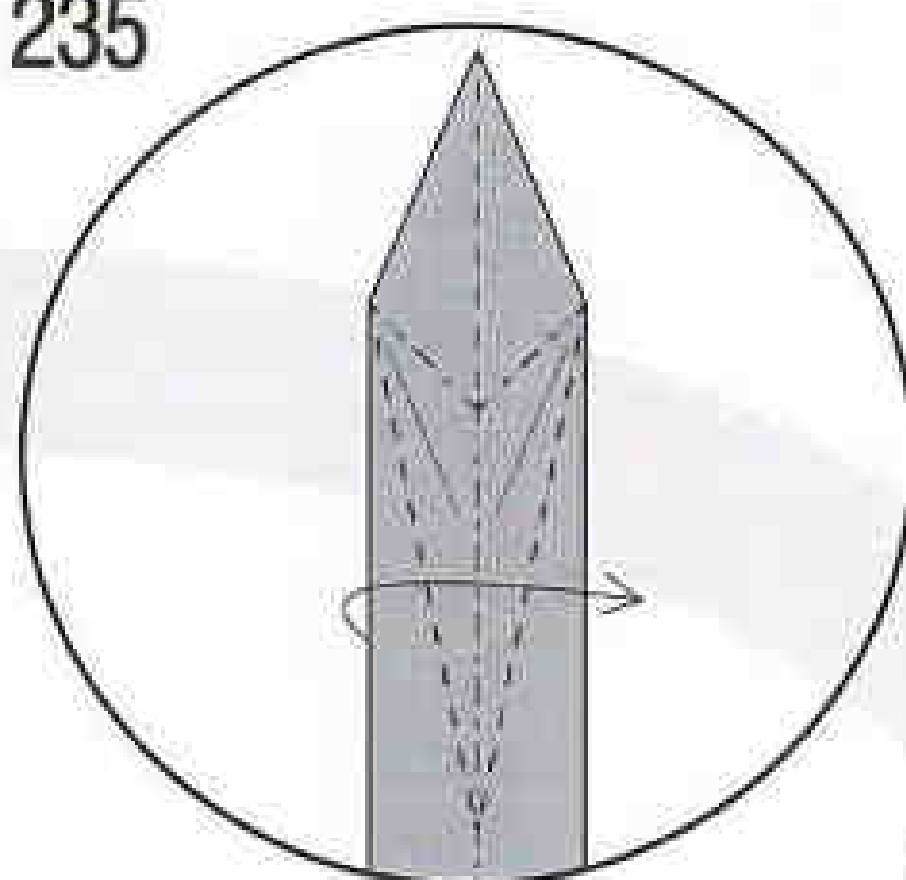

236

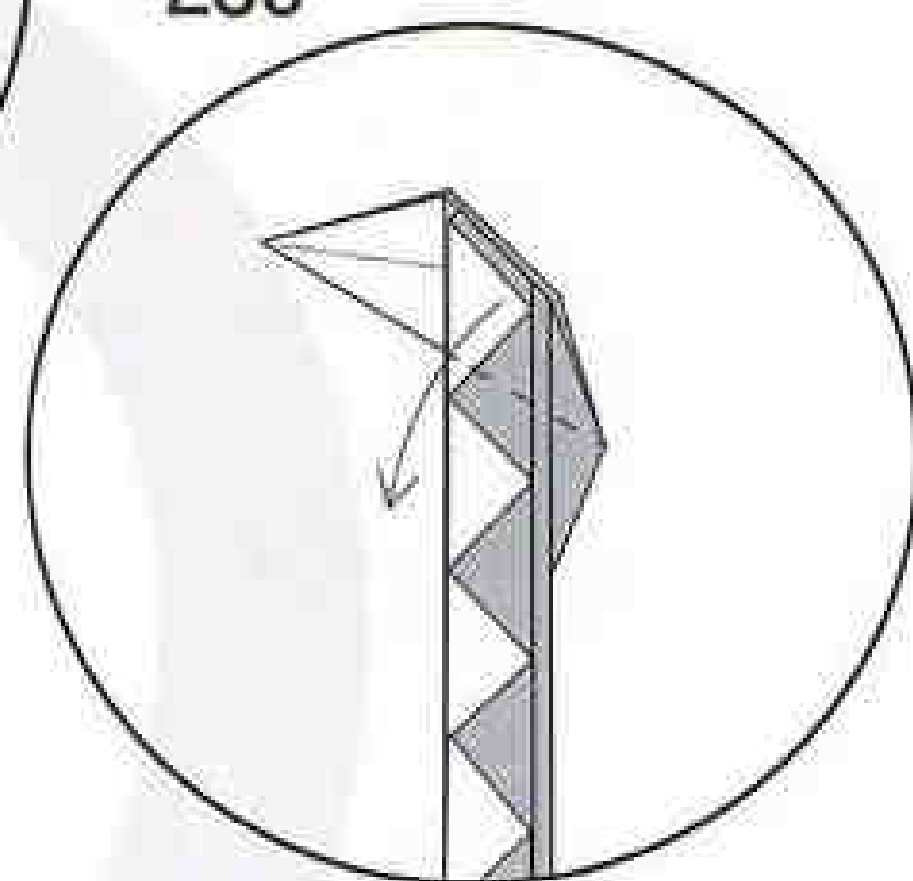

238



237

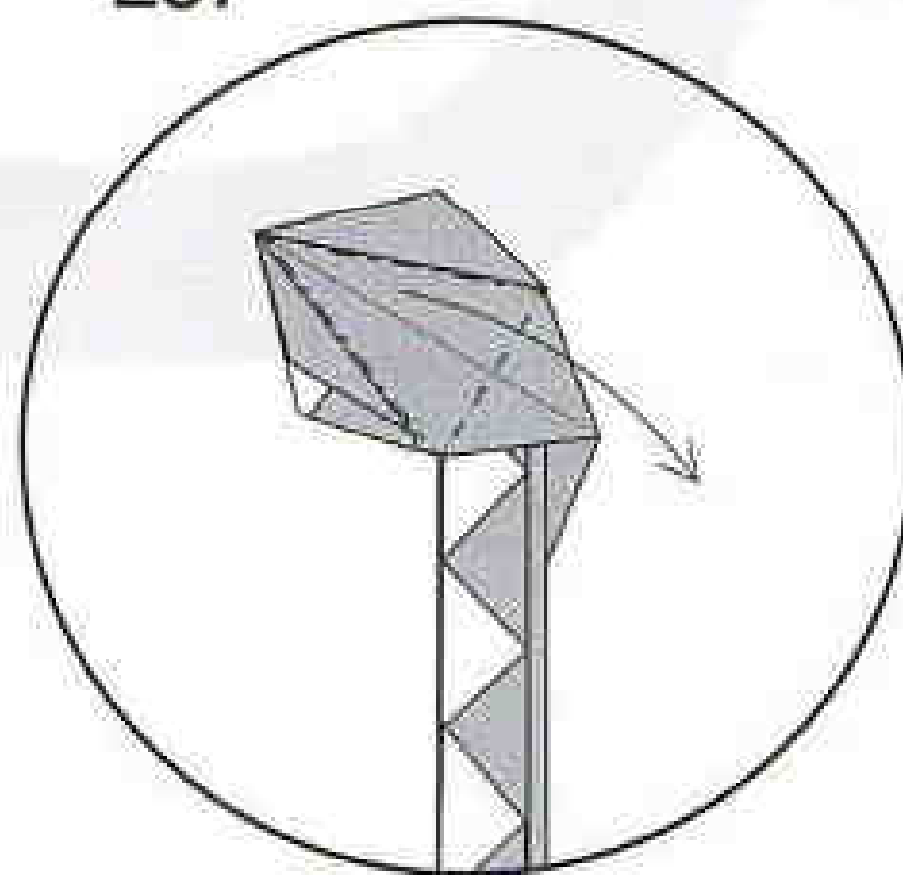

239

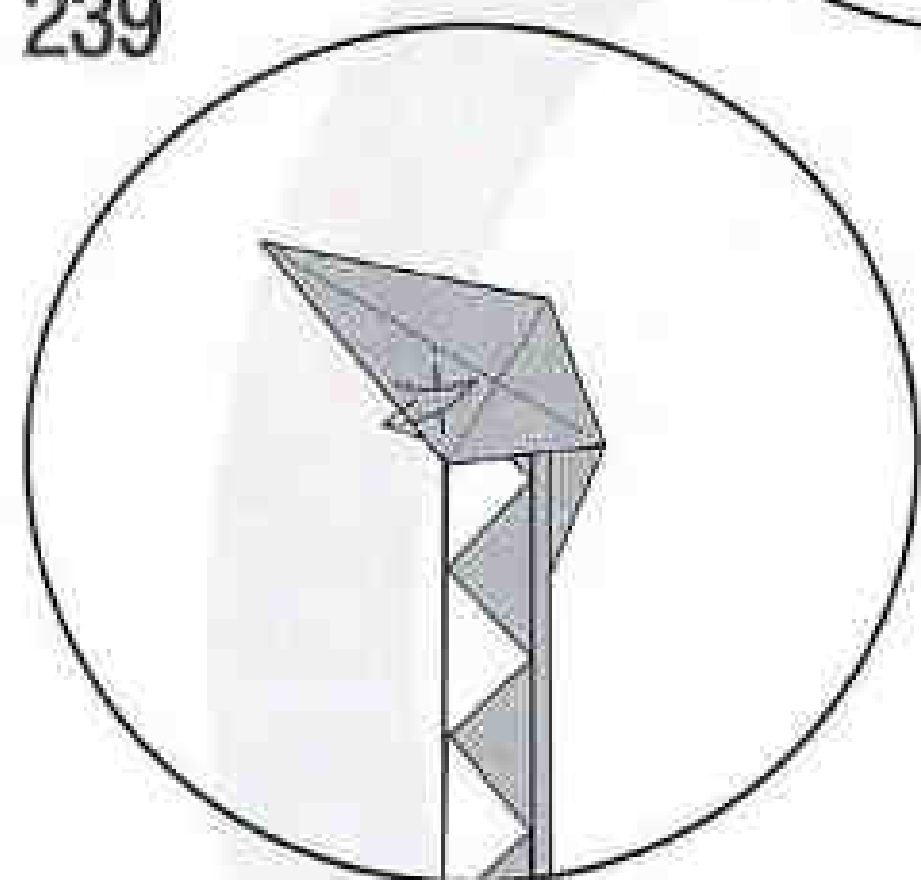

242

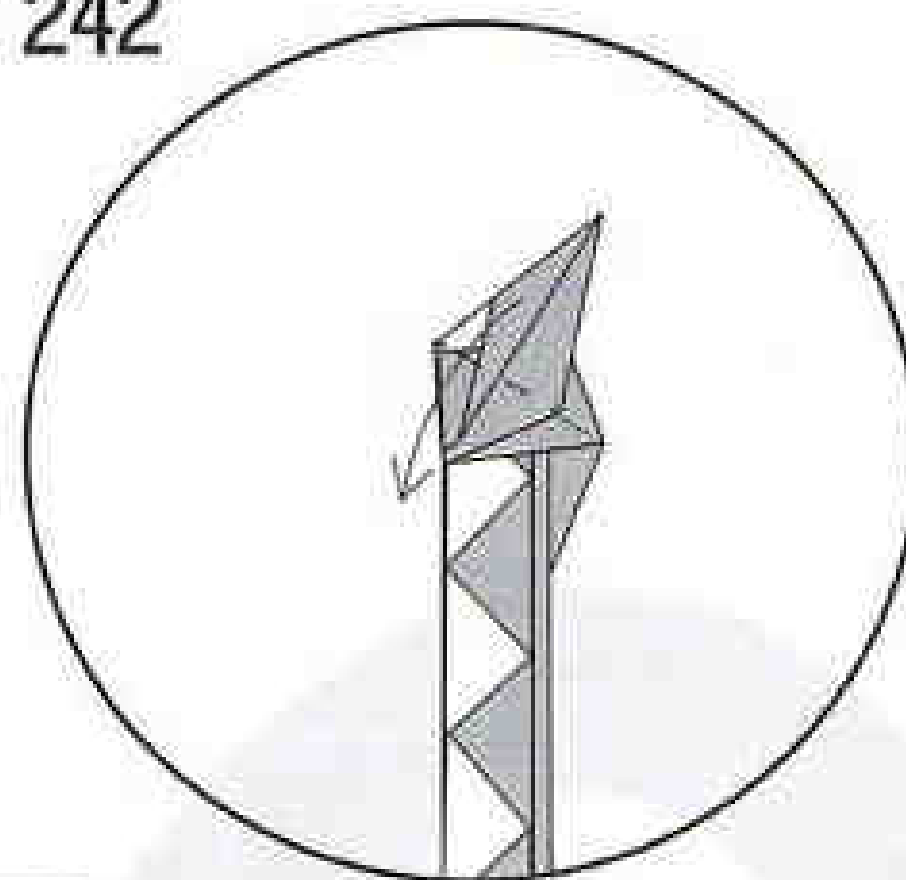

240

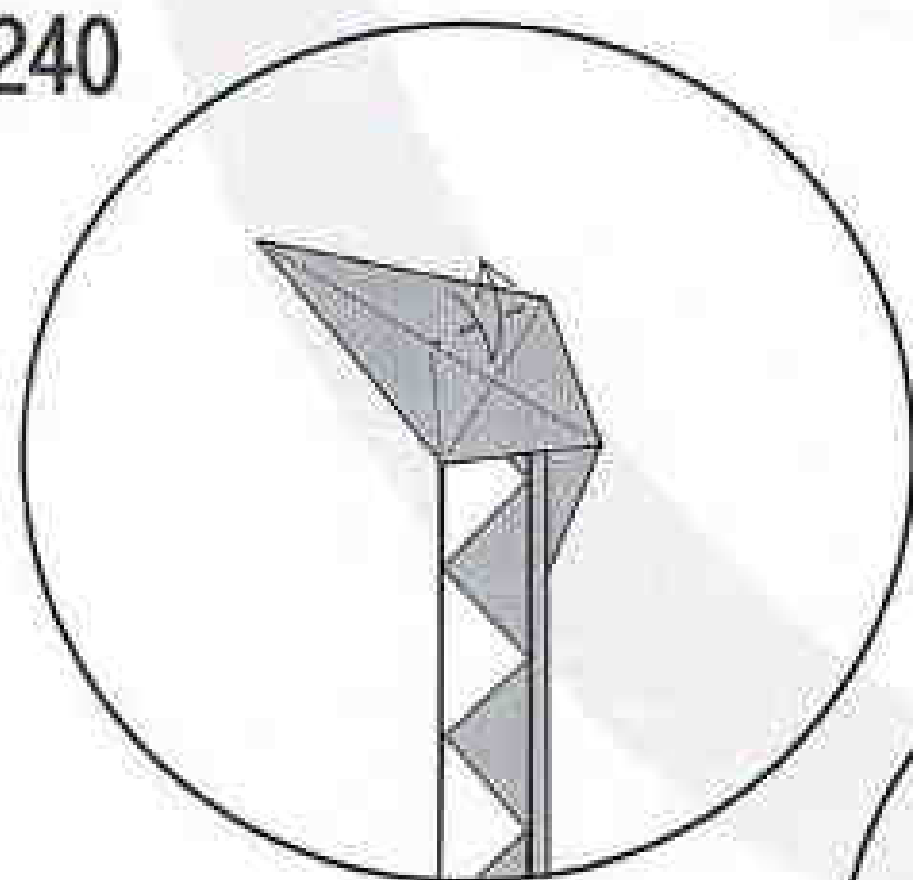

241

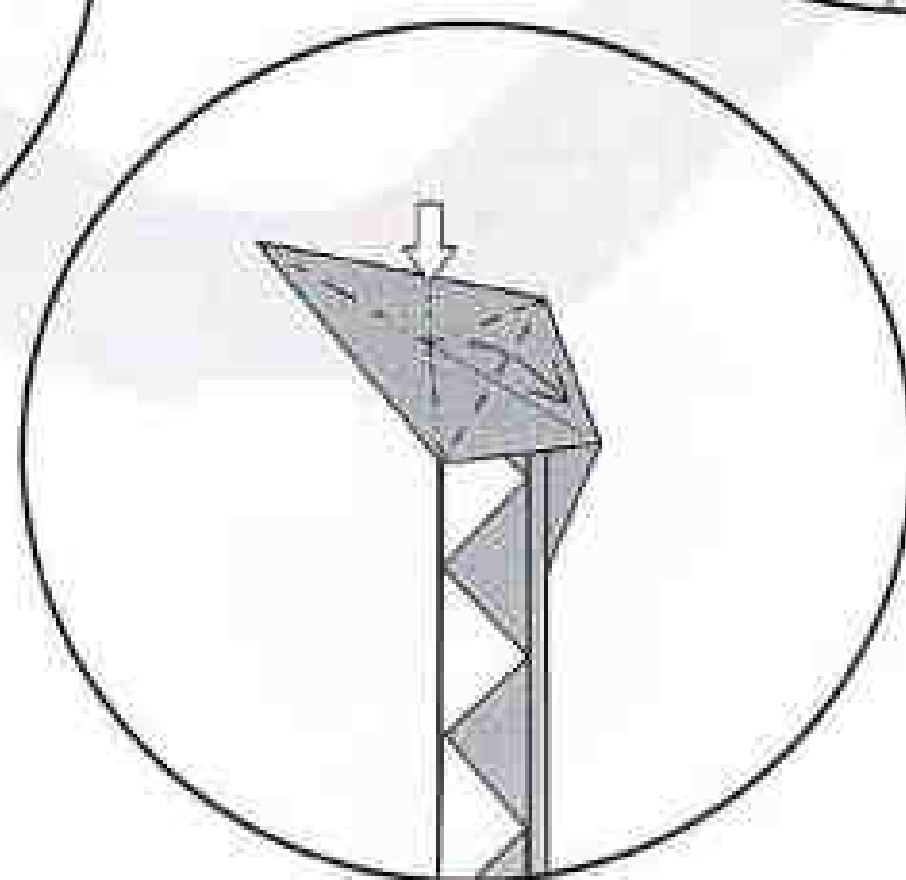

243

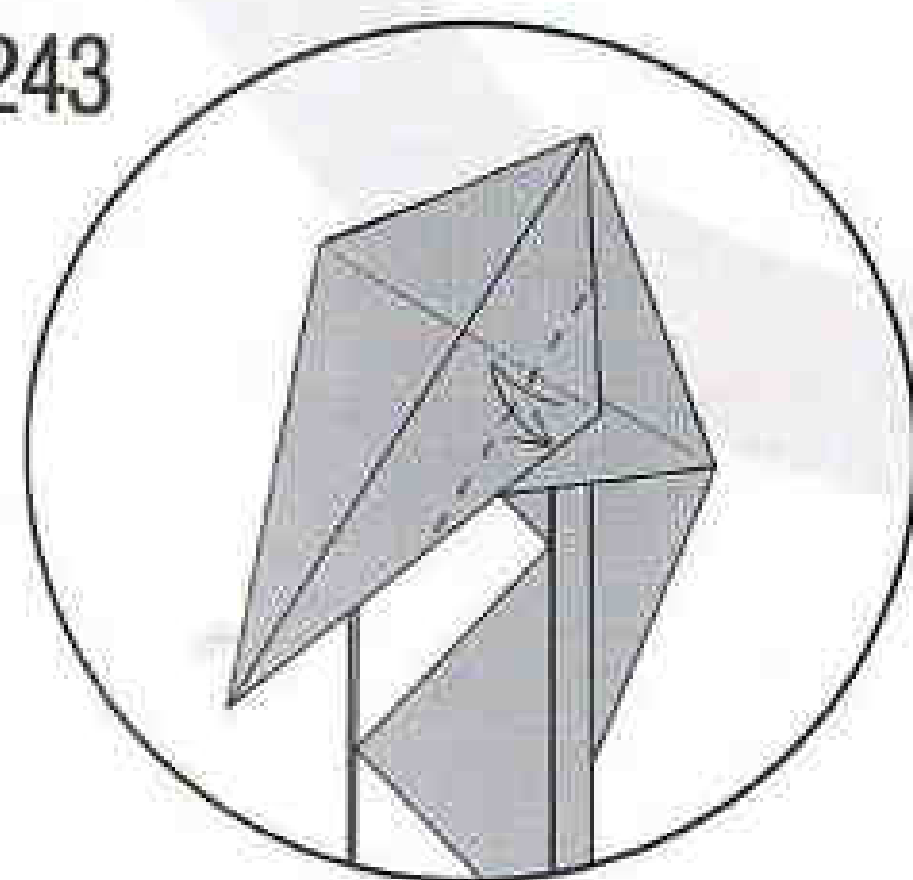

251

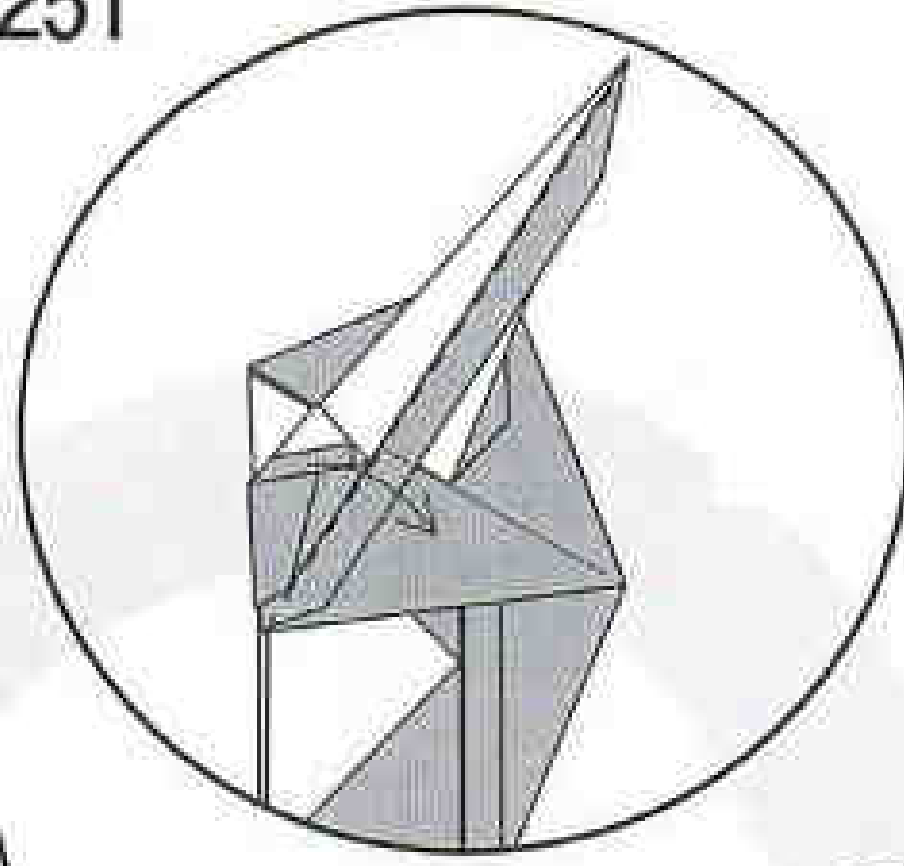

253

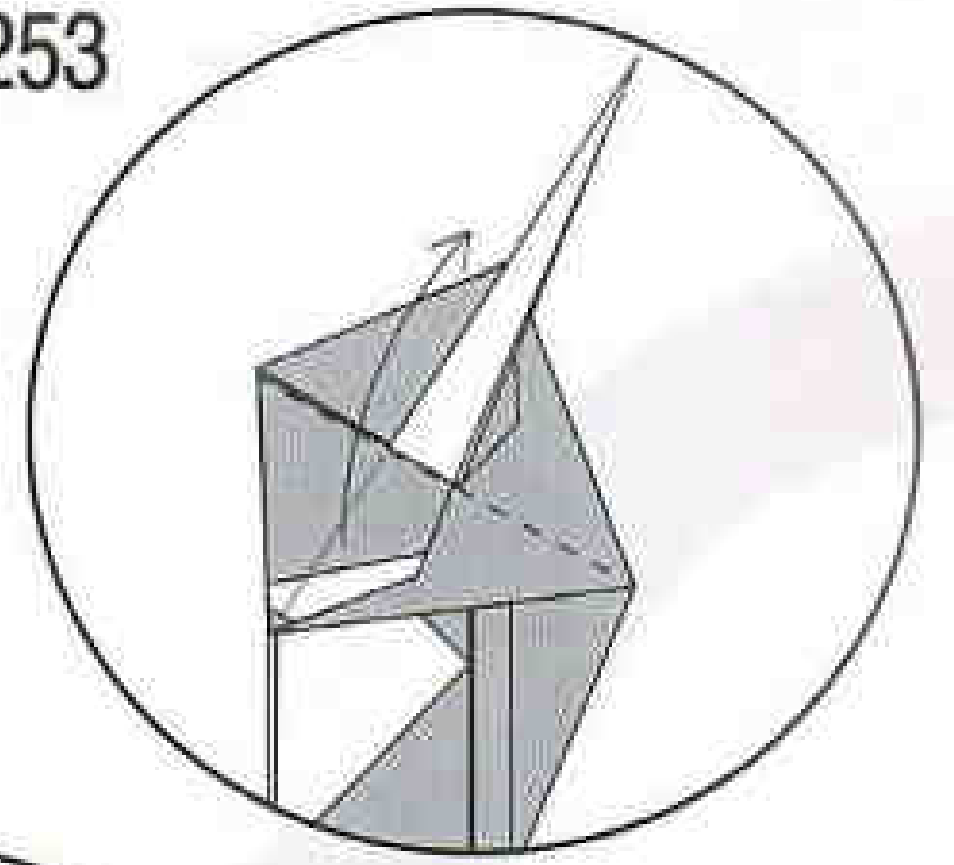

250

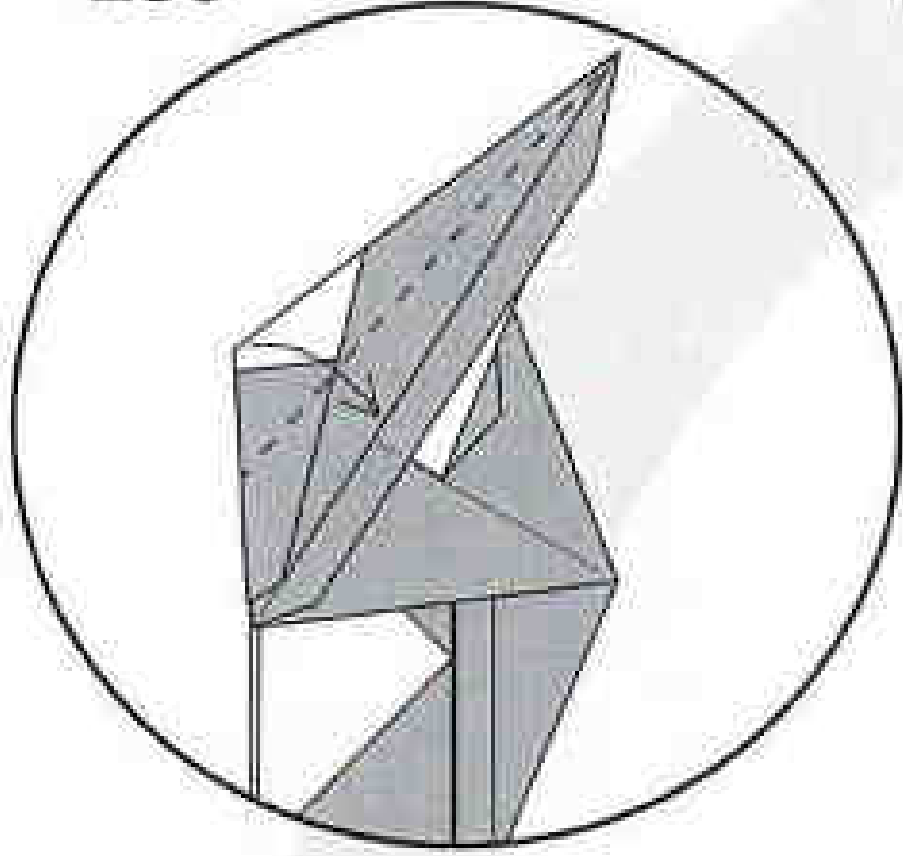

252

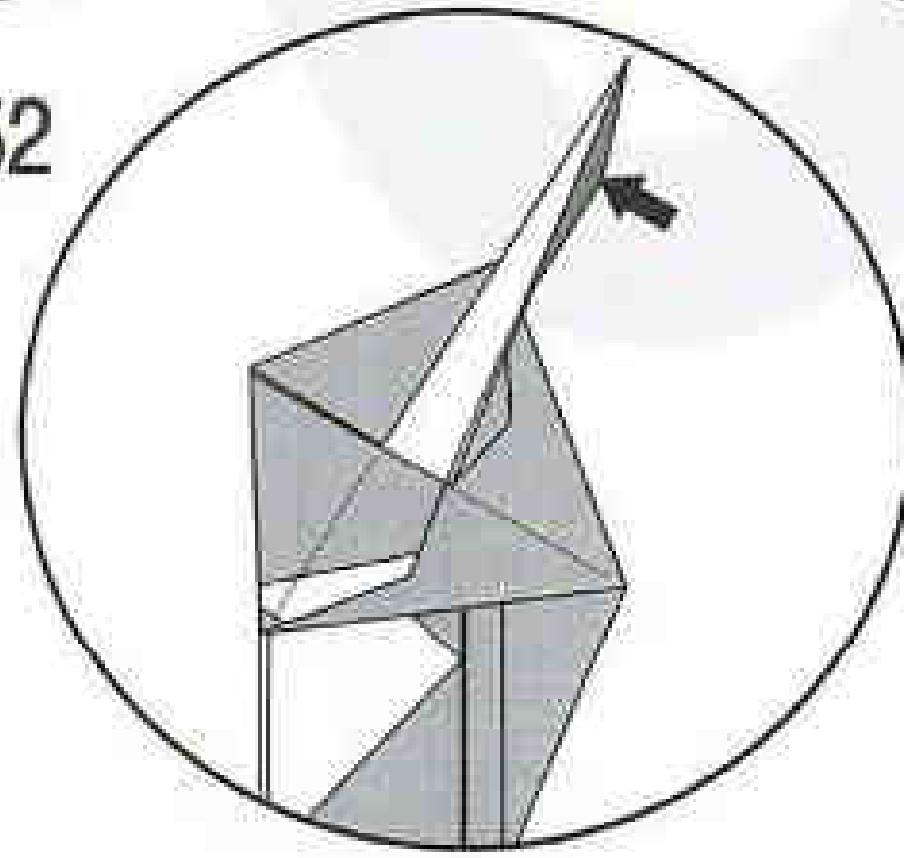

249

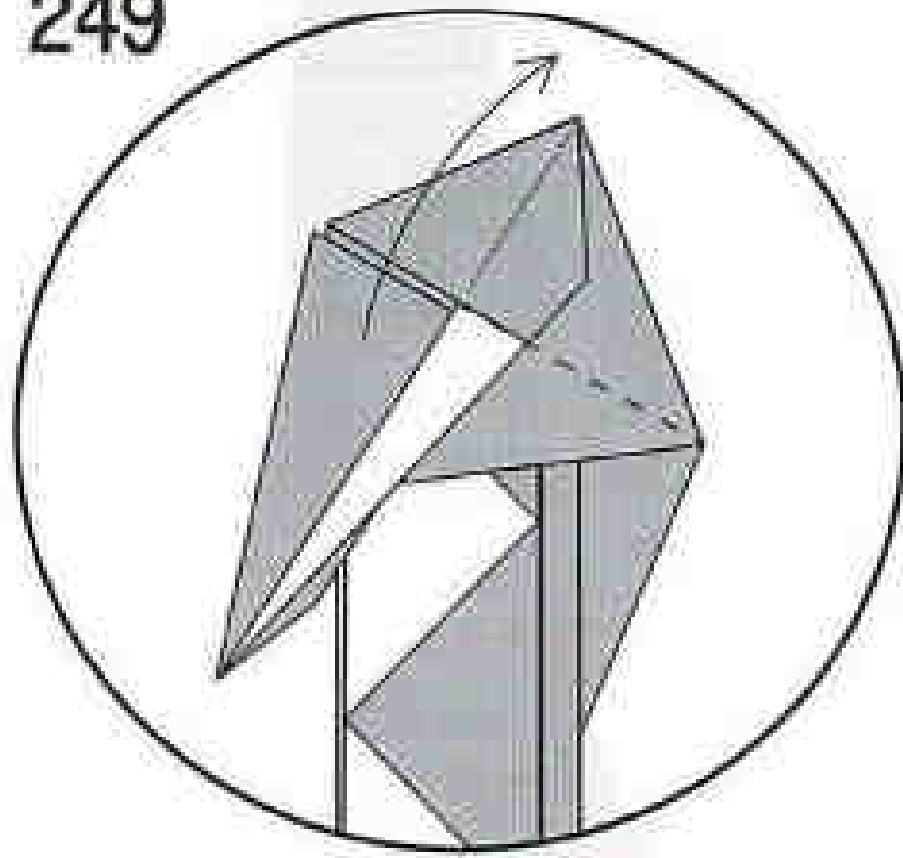

247

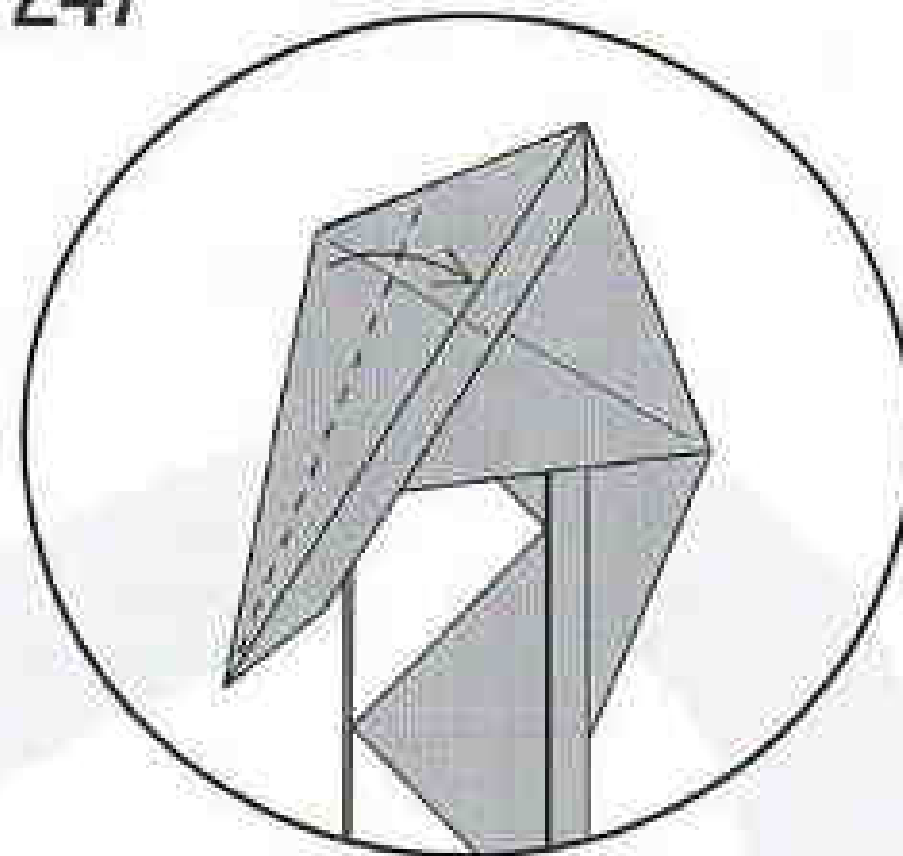

248

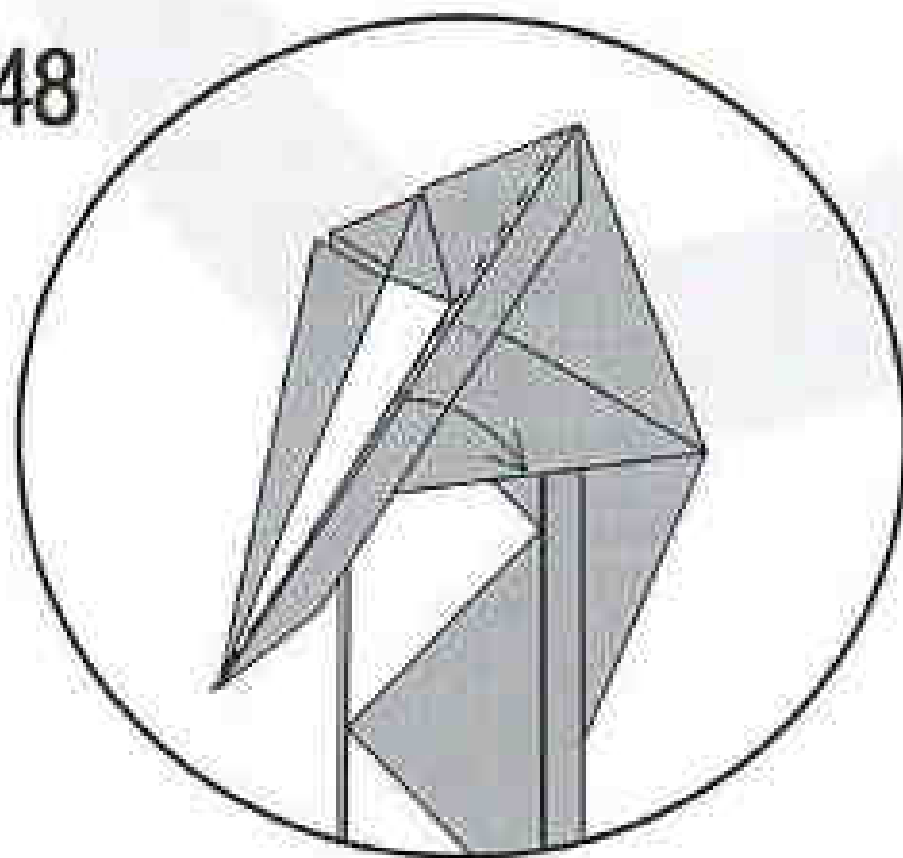

246

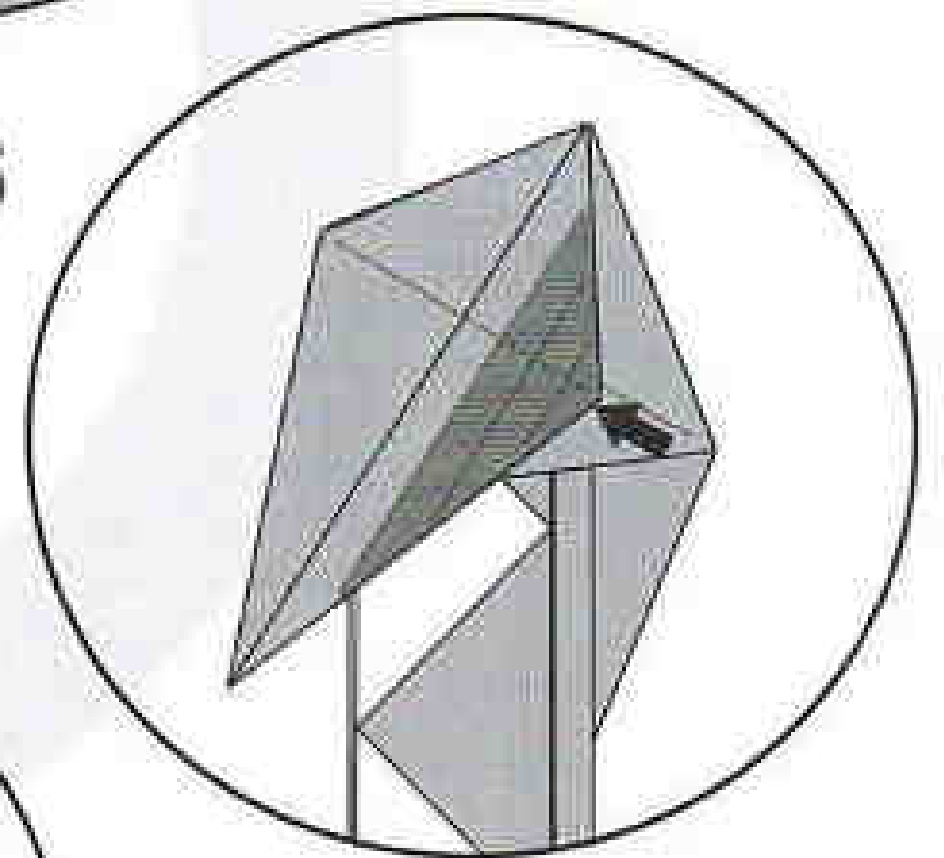

244

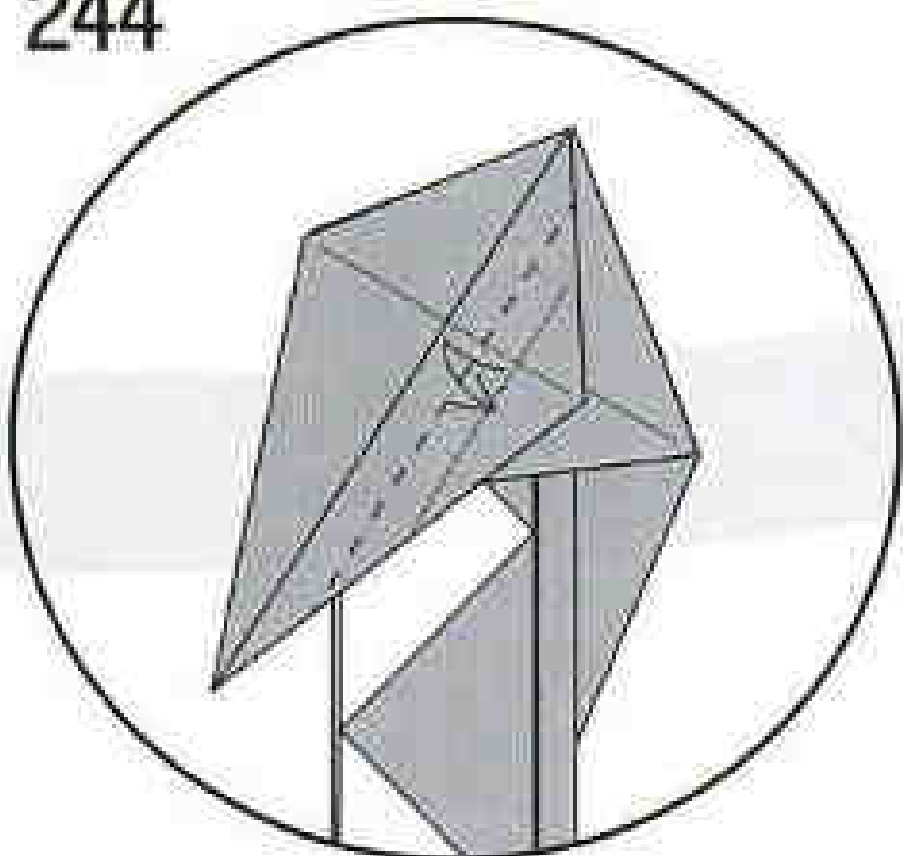

245

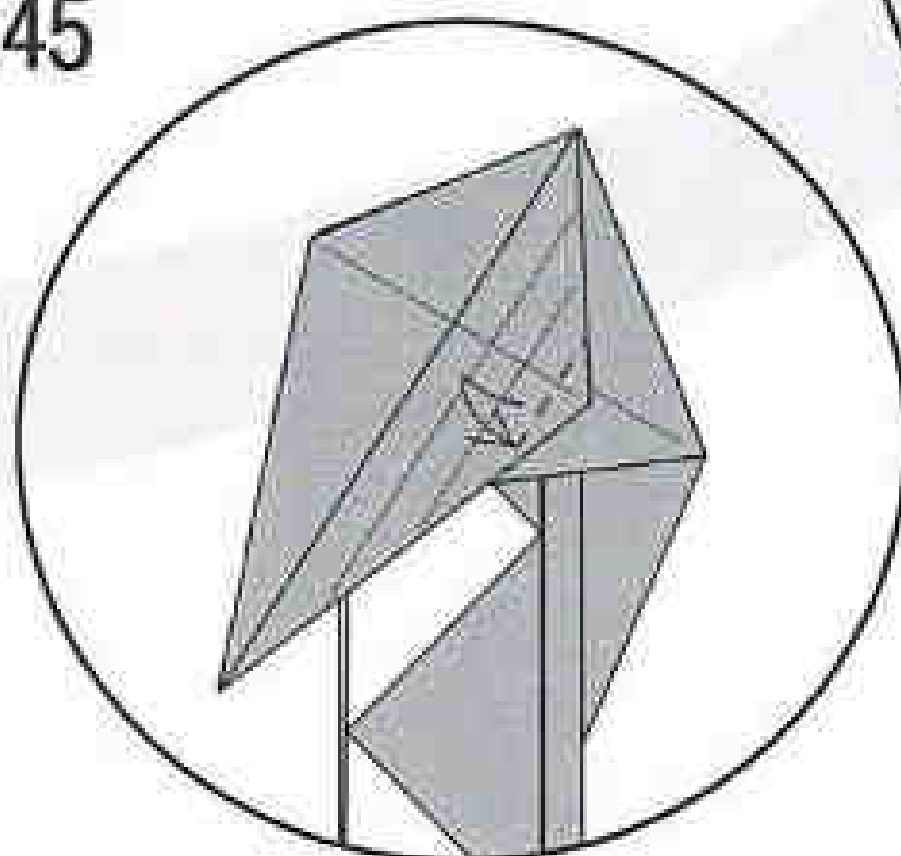

254

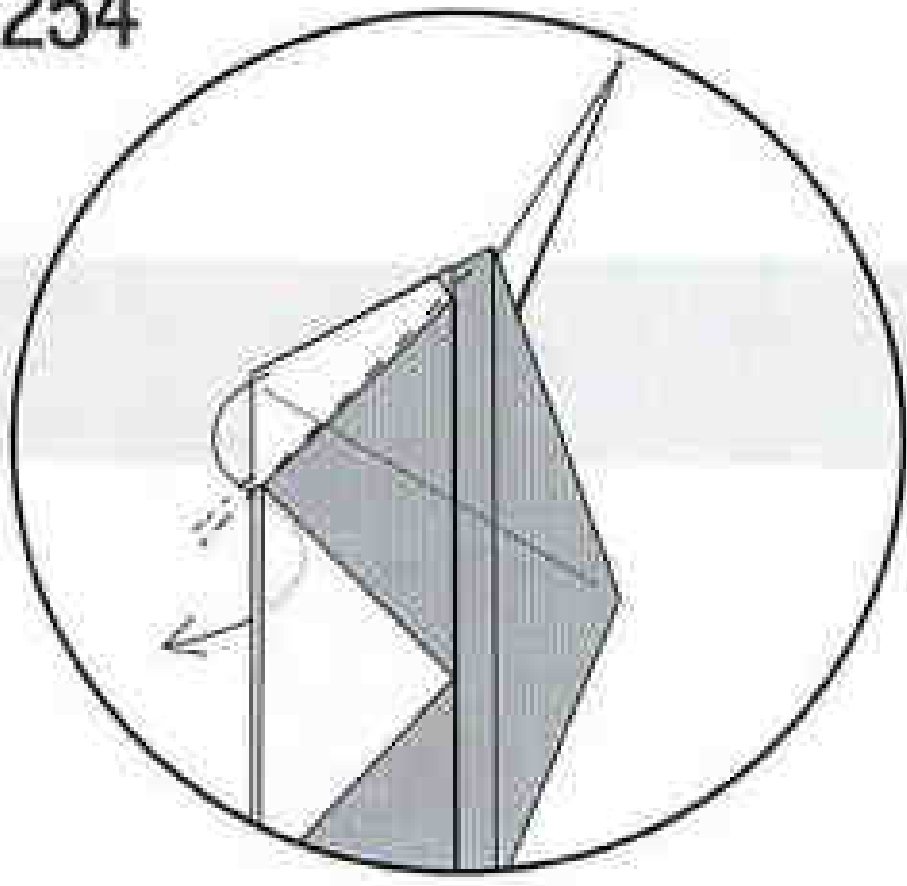

256

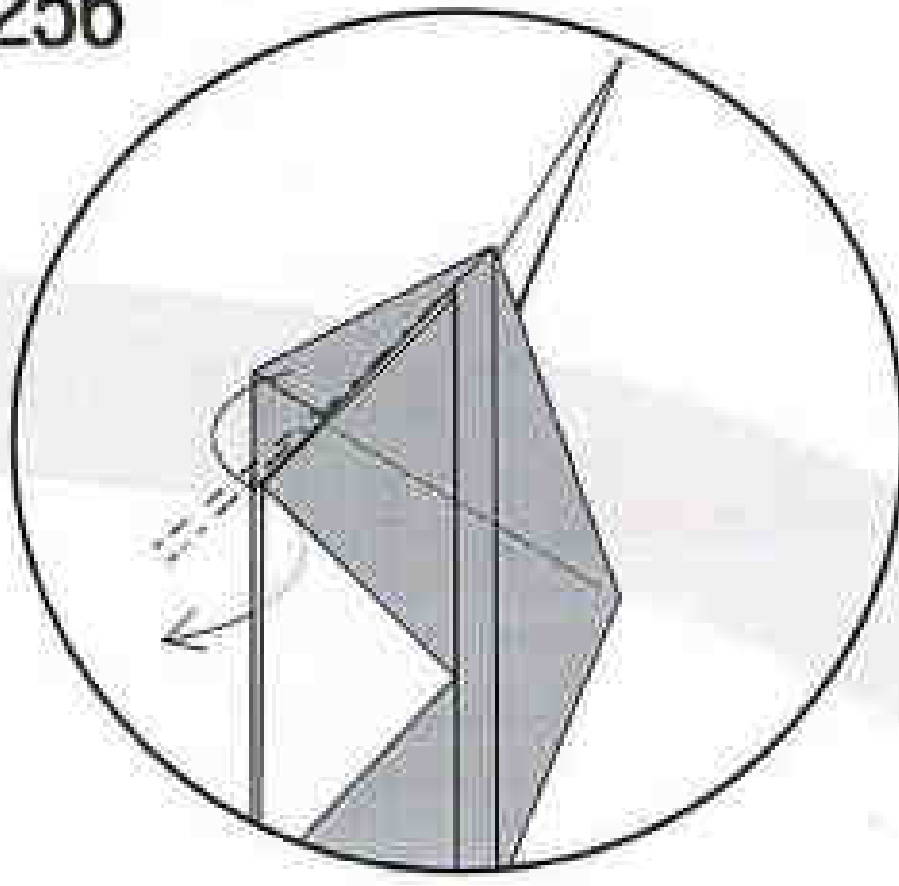

257

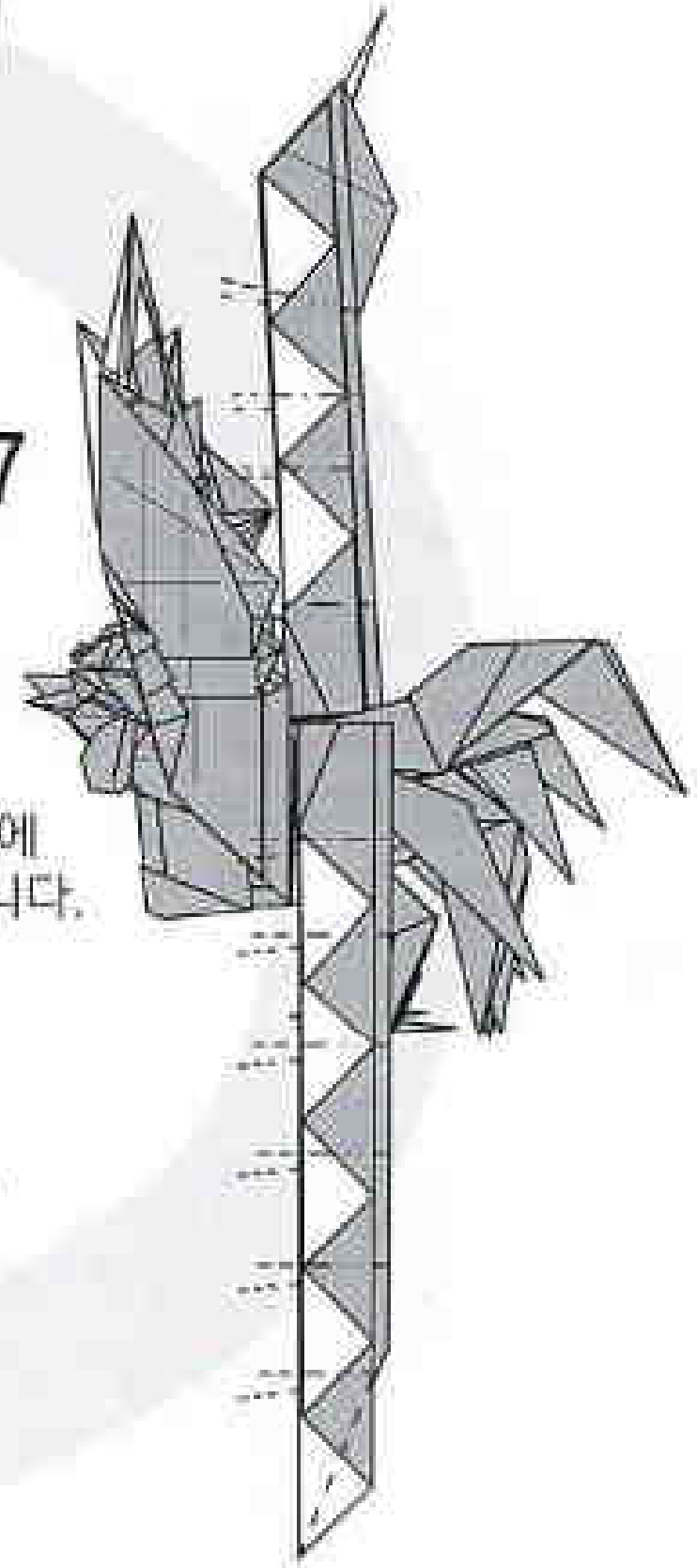

완성

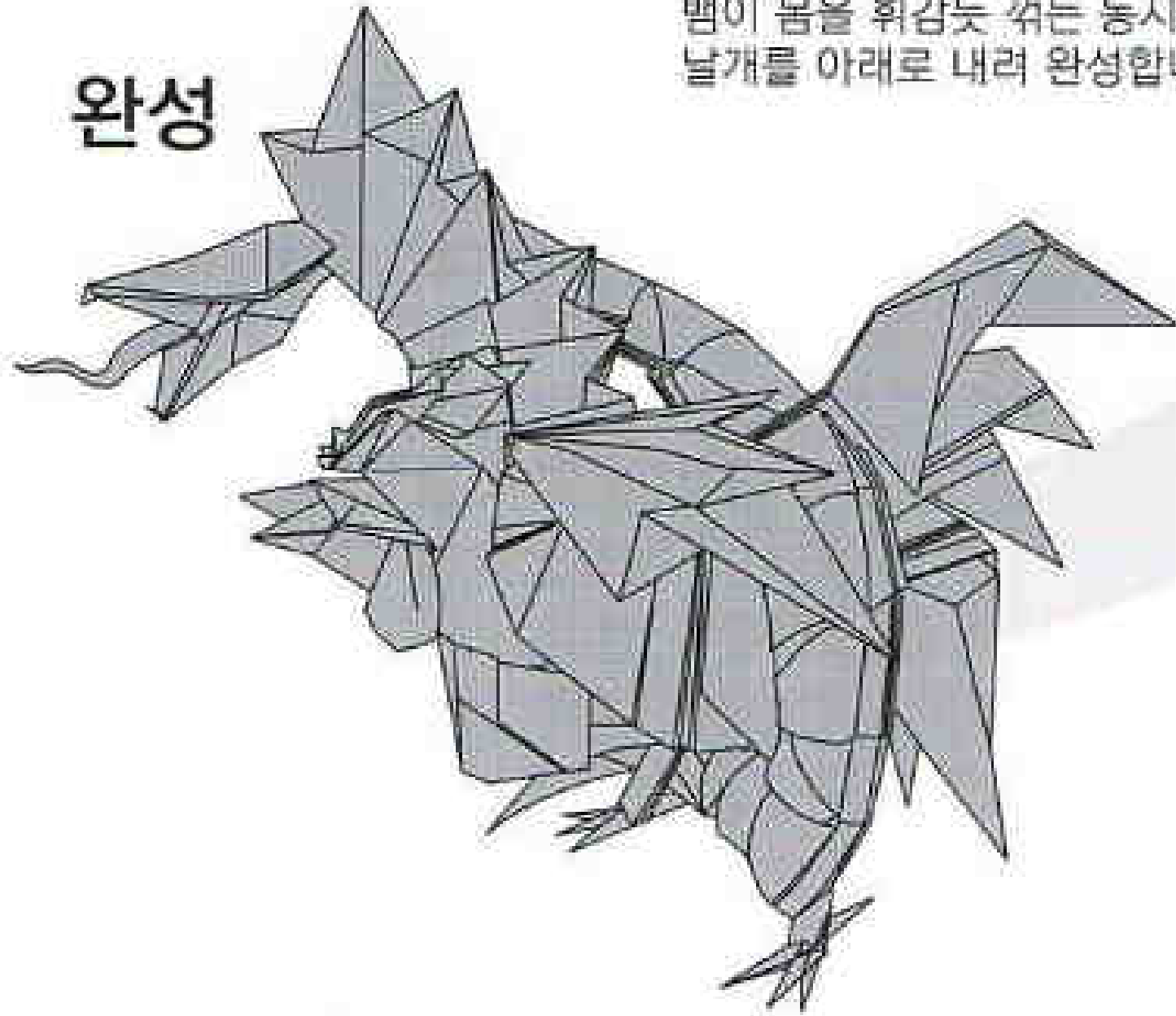

뱀이 몸을 휘감듯 꺾는 동시에 날개를 아래로 내려 완성합니다.

해외 작품

Foreign - Models

도마뱀 (Lizard)

창작가 : 호만 디아즈 (Roman Diaz)
 포토다이아그램 : 김진우 (Kim Jin Woo)
 다이어그램 : 김영민 (Kim Young Min)

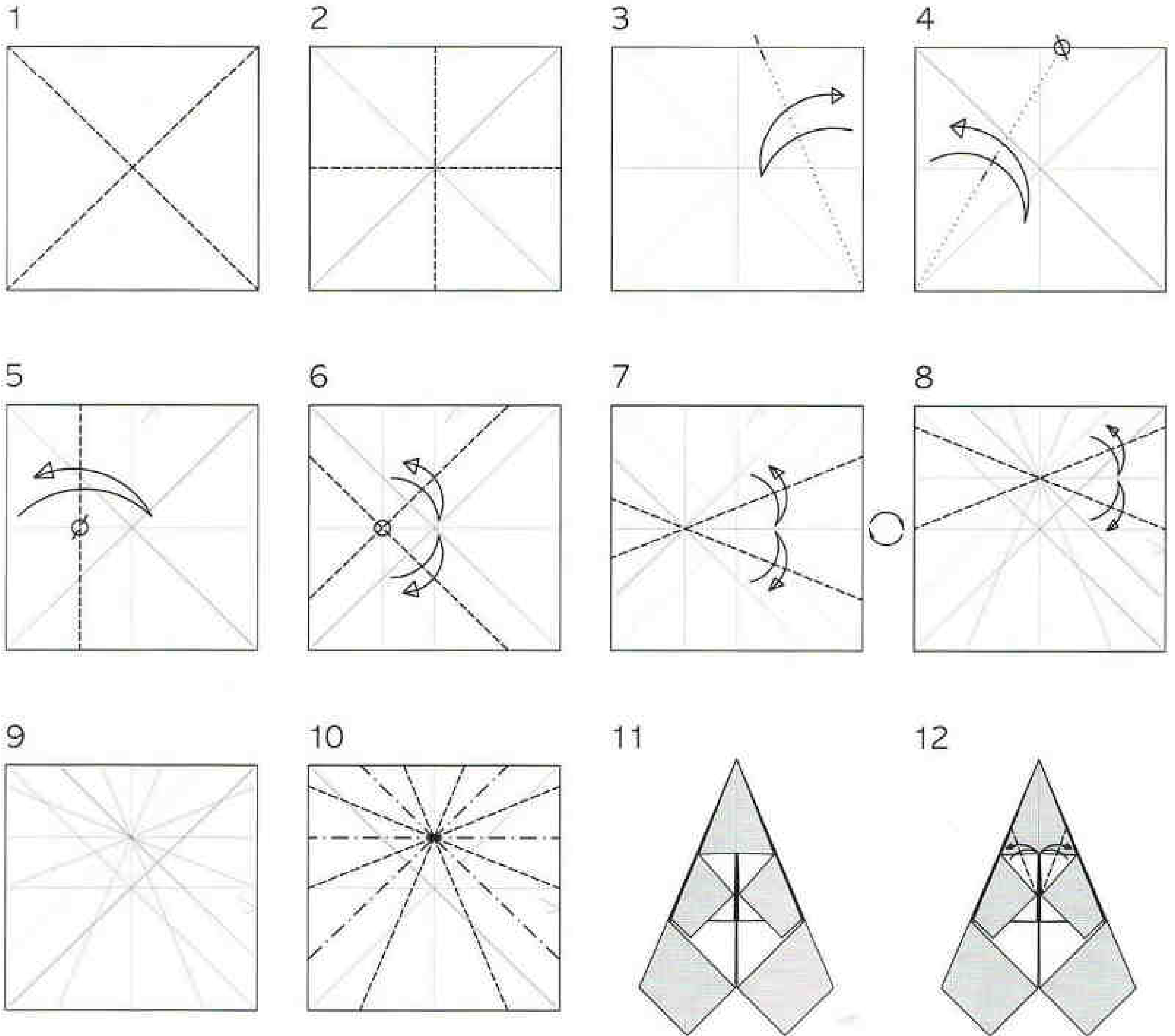
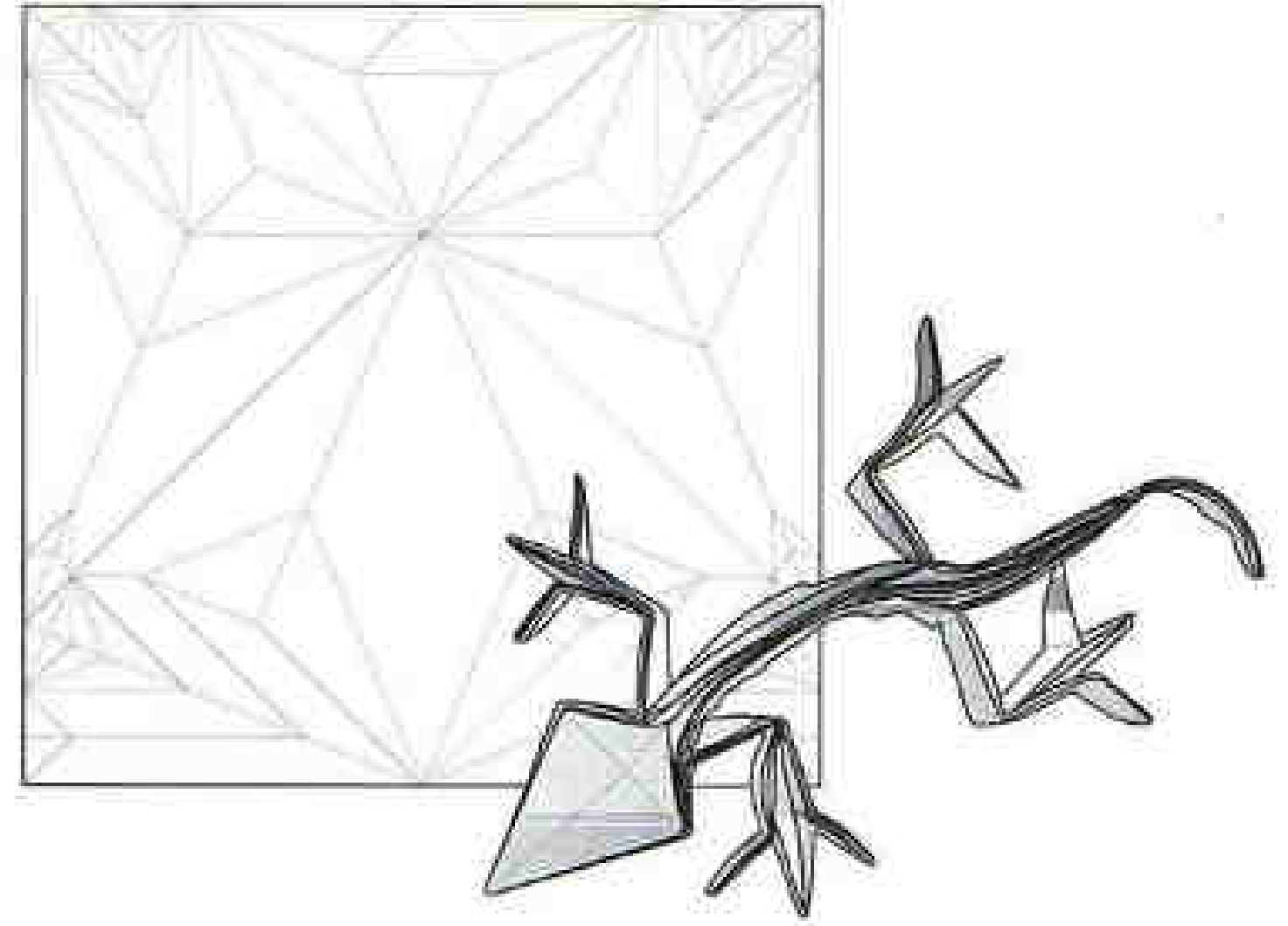

13

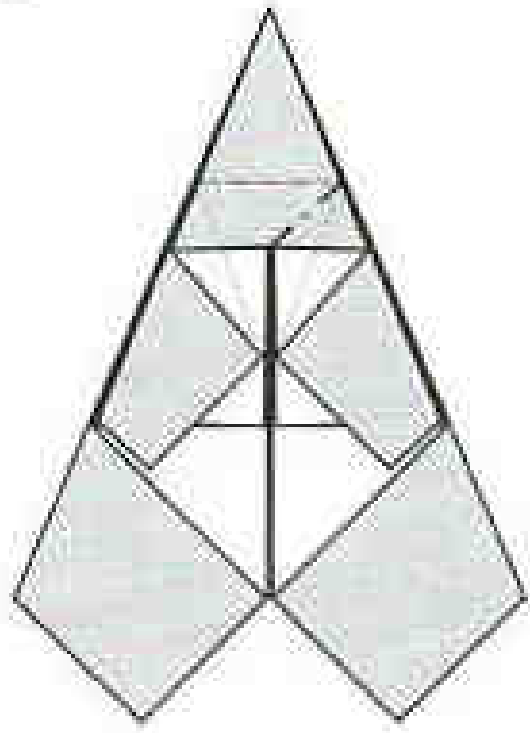

14

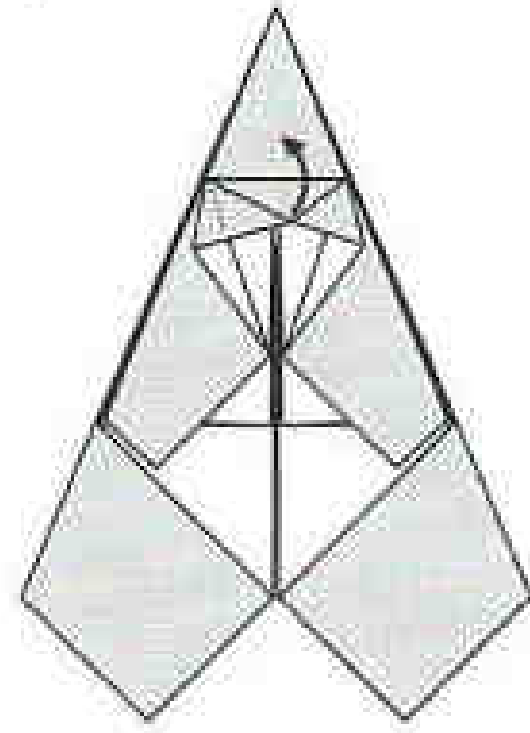

15

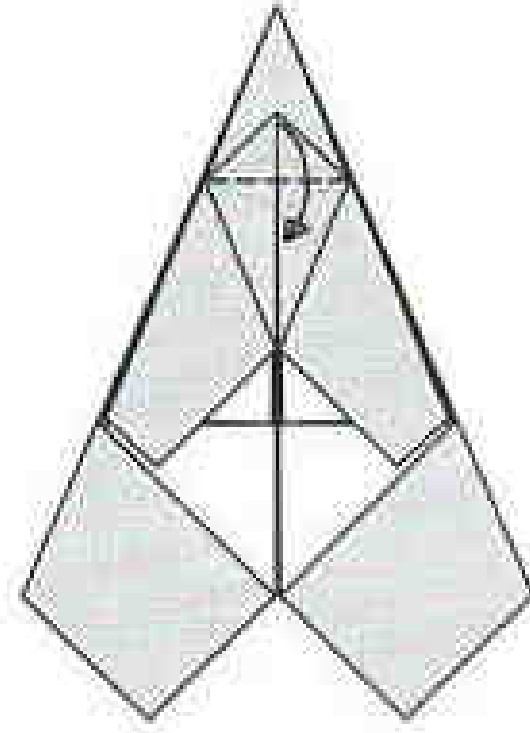

16

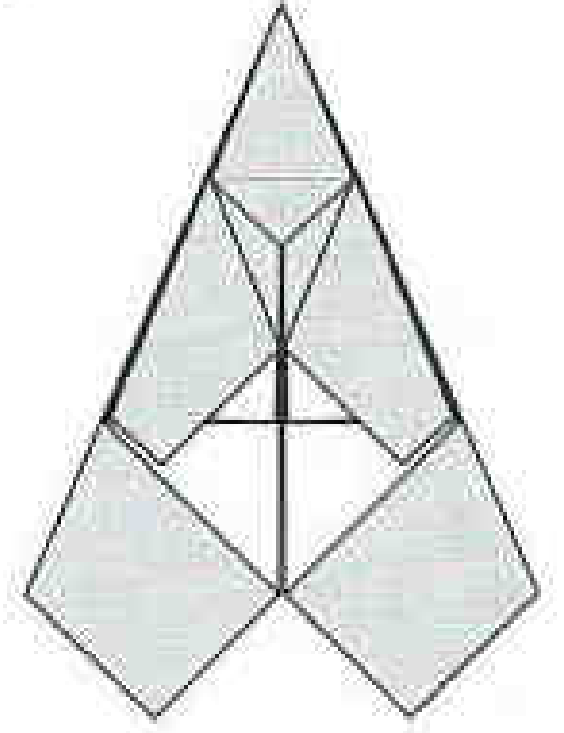

17

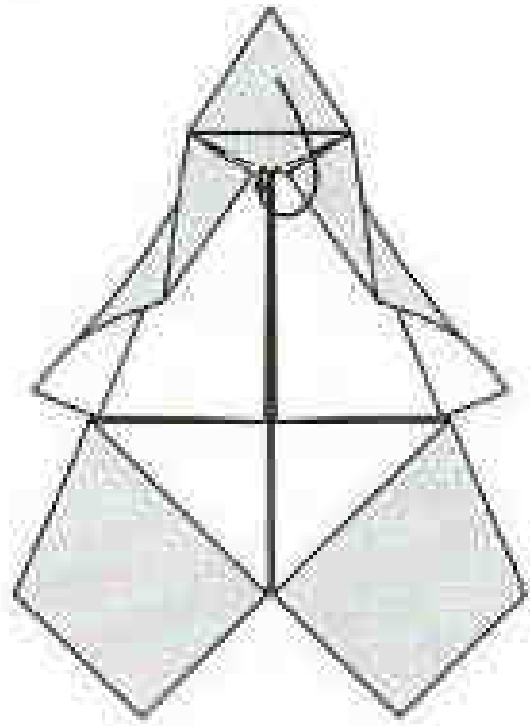

18

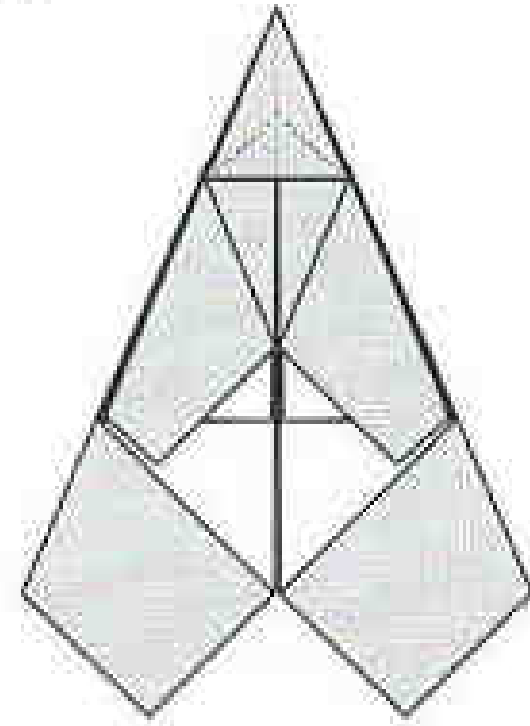

19

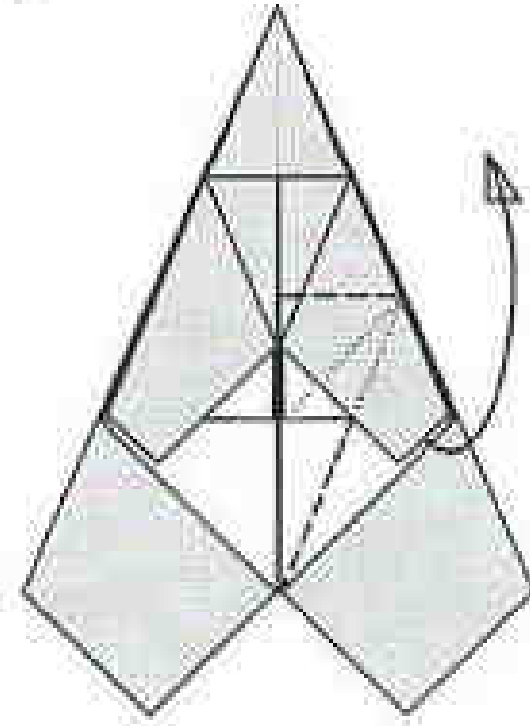

20

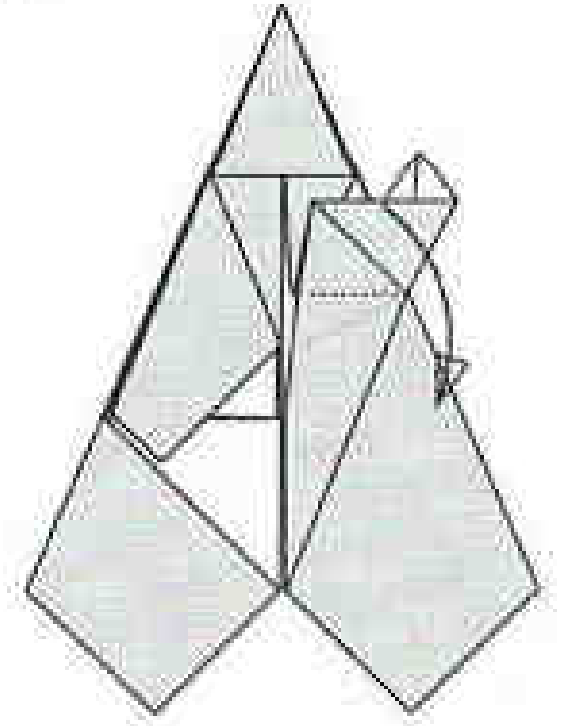

21

19-20

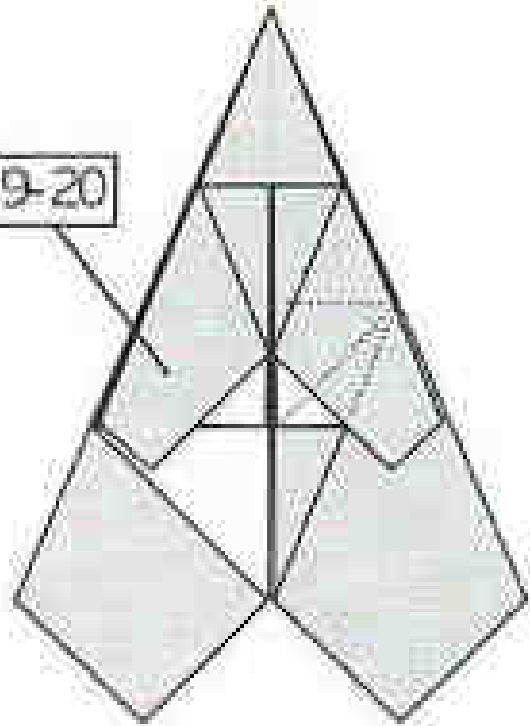

22

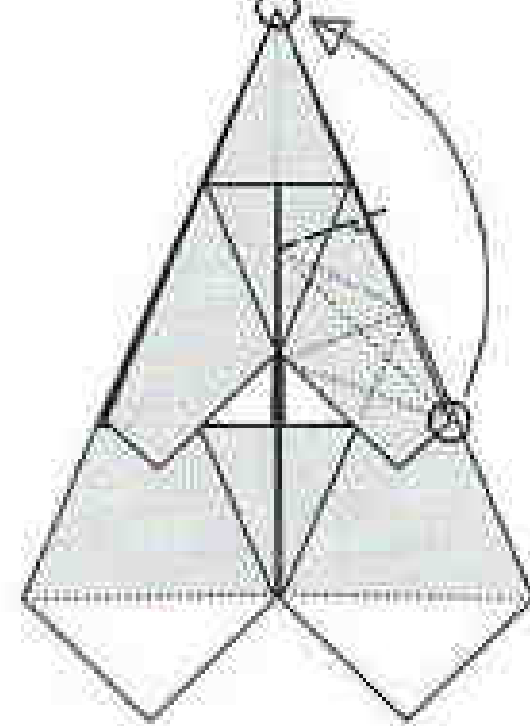

23

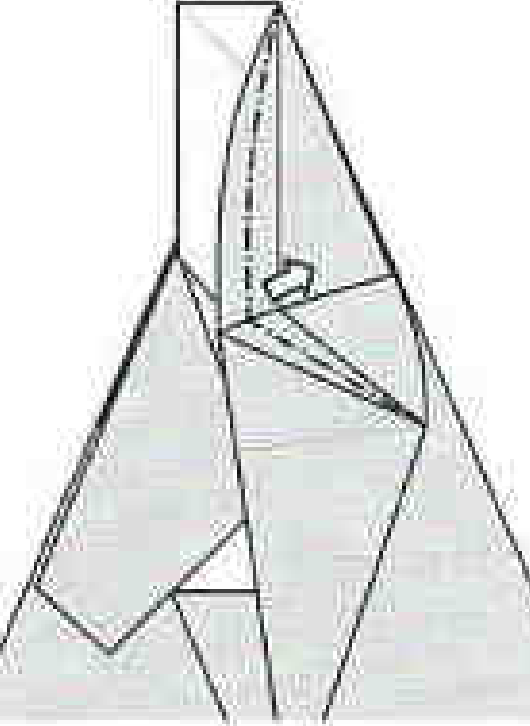

24

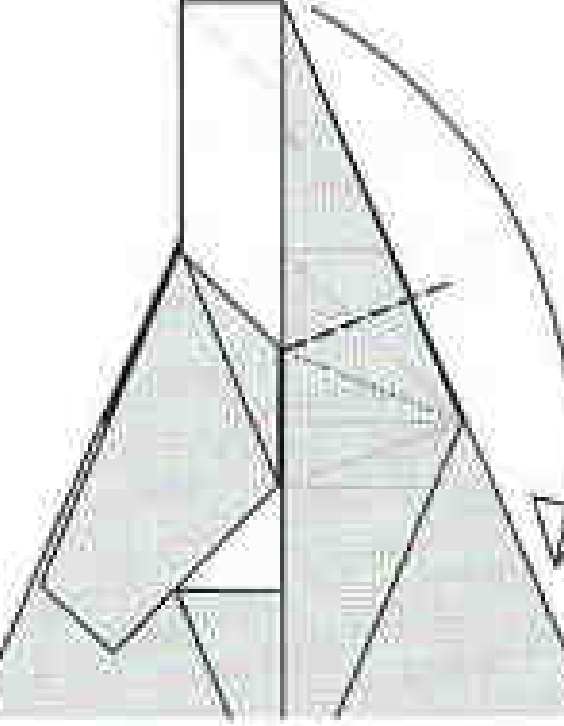

25

22-24

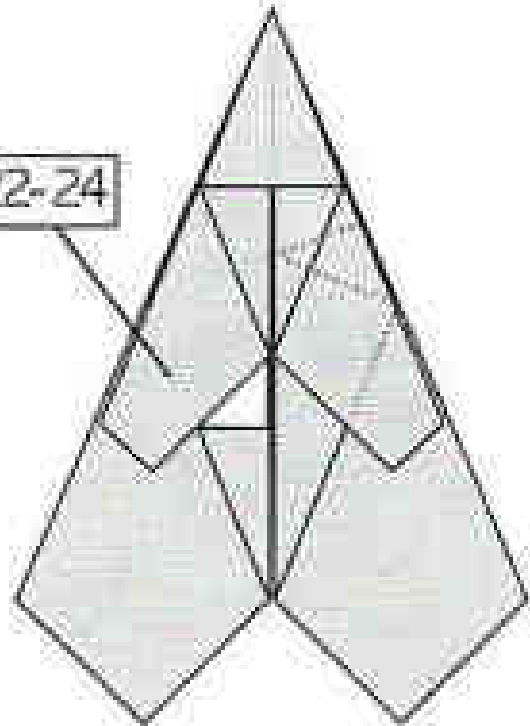

26

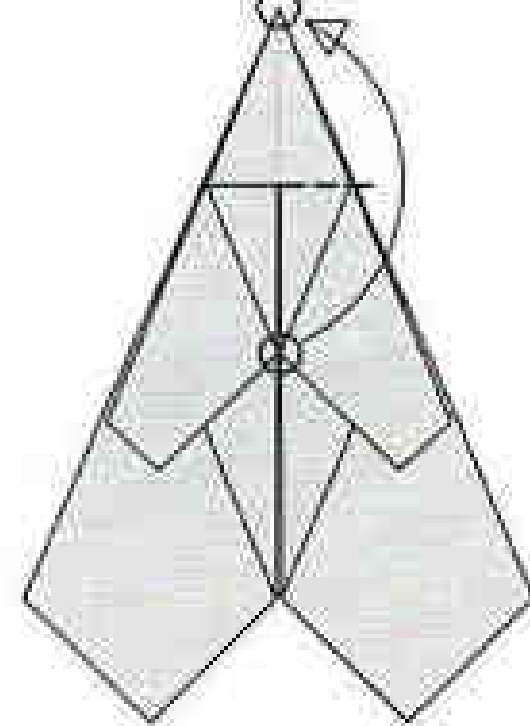

27

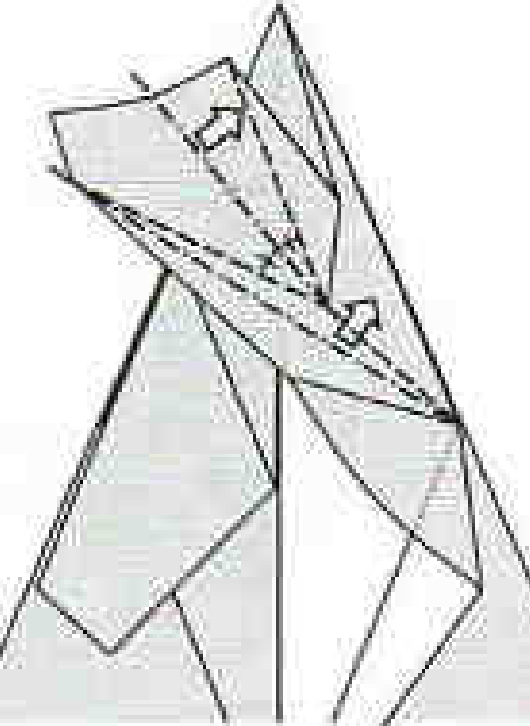

28

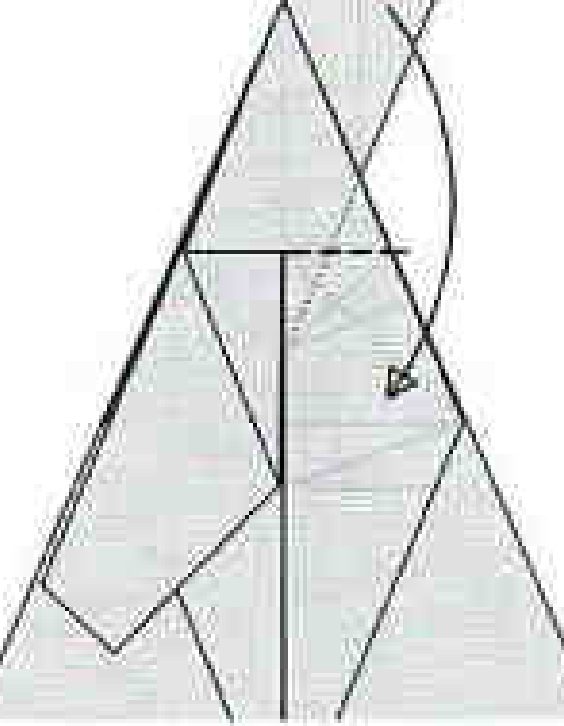

29

26-28

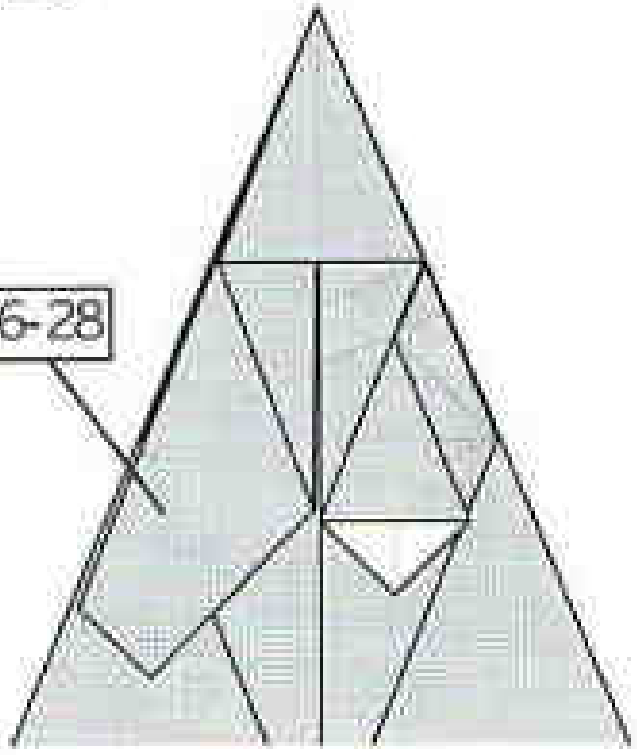

30

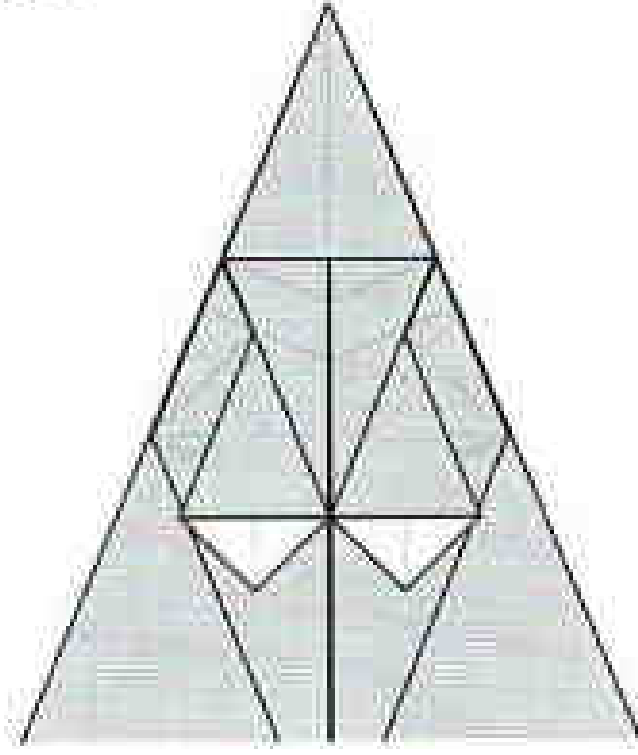

31

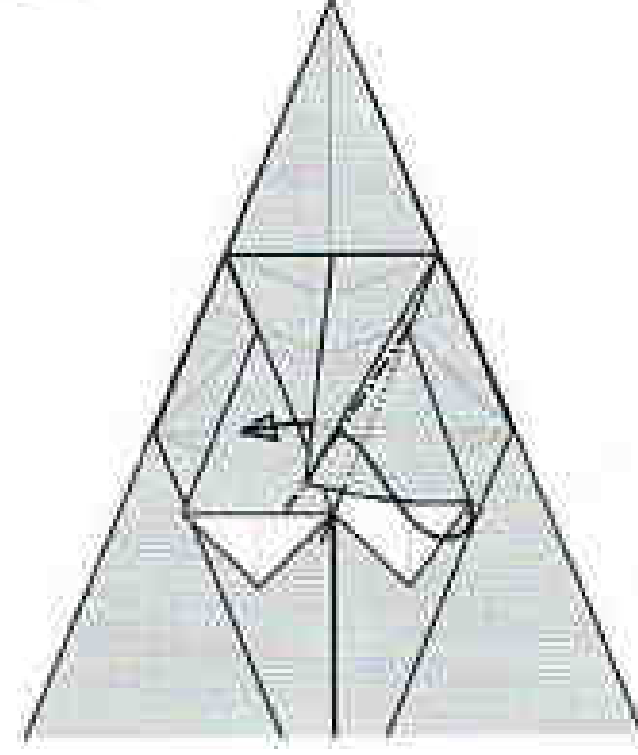

32

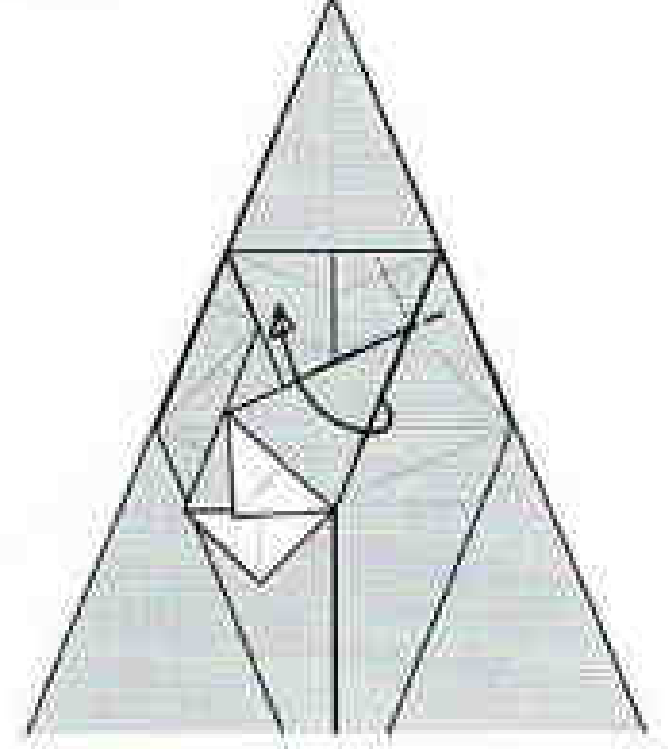

33

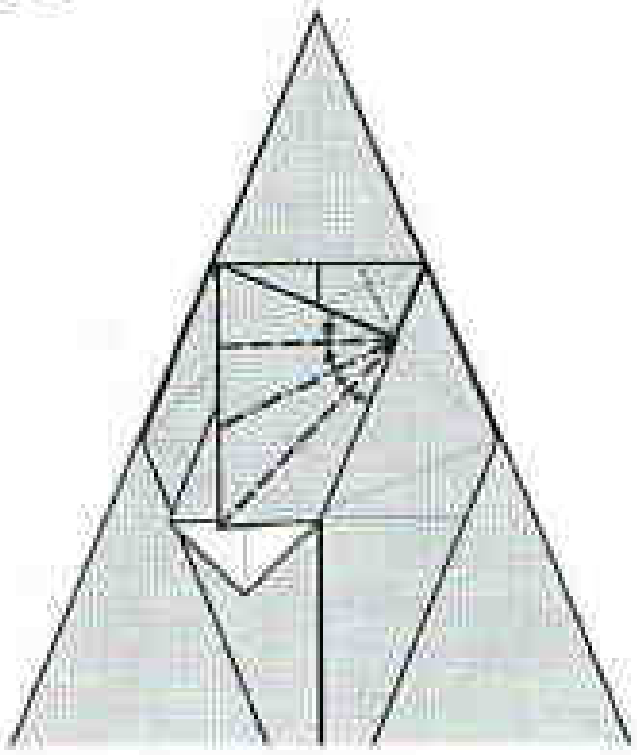

34

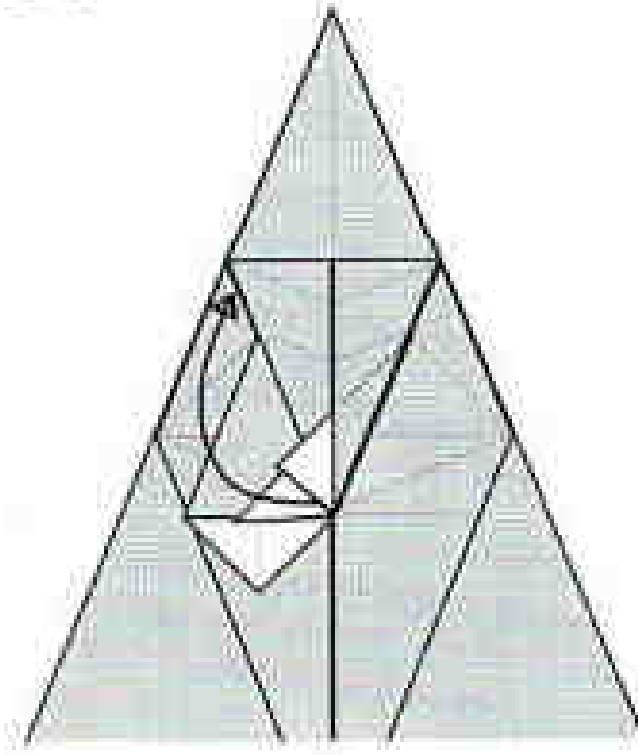

35

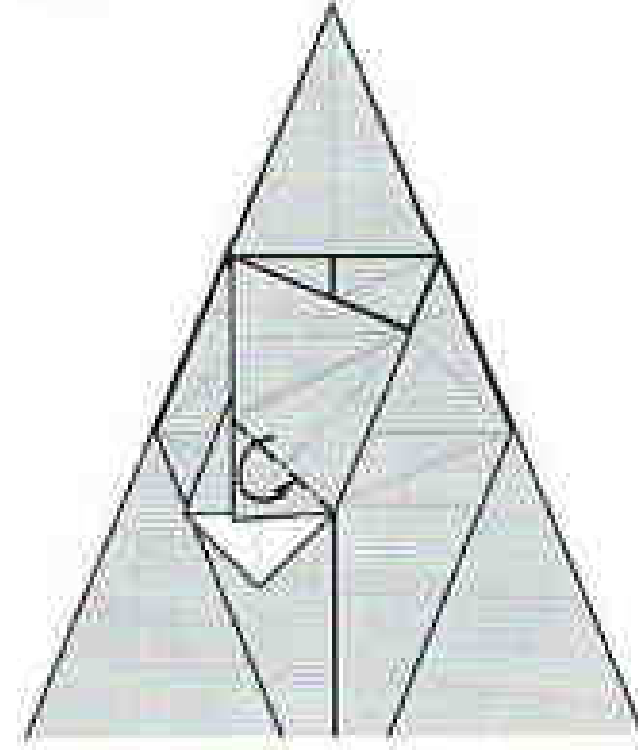

36

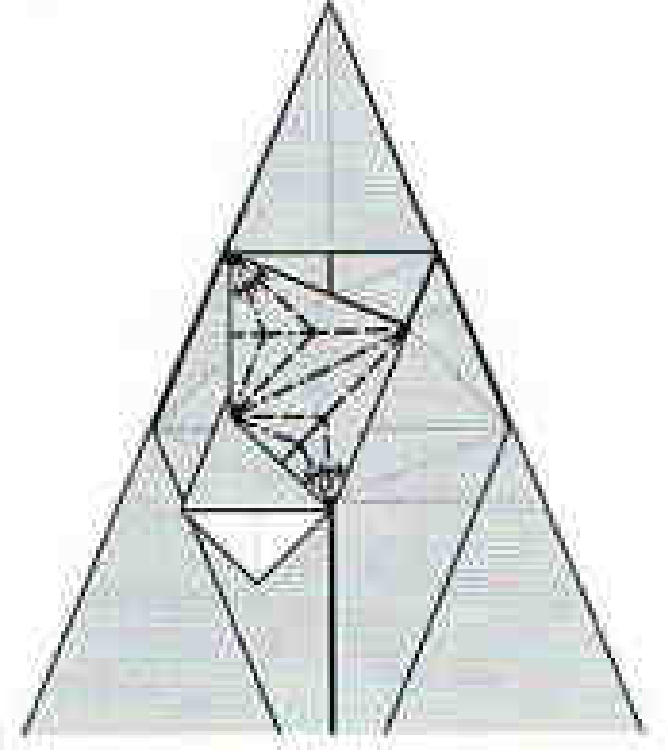

37

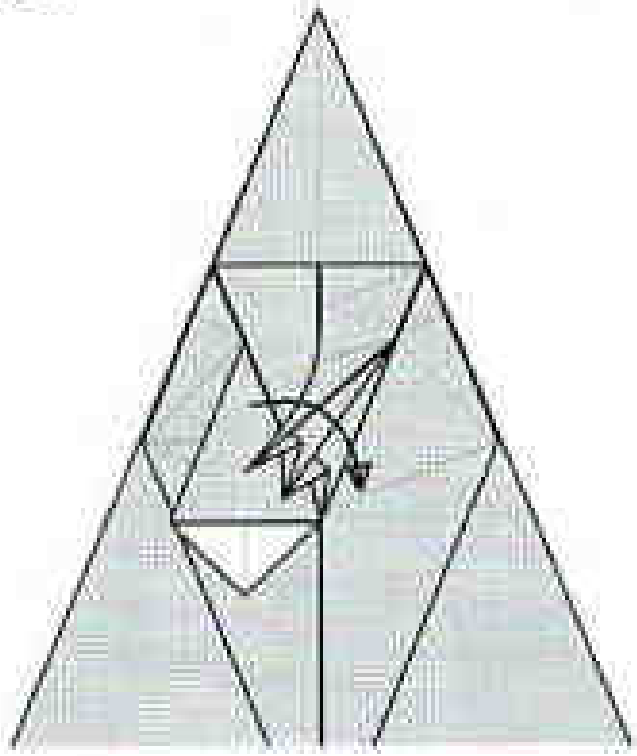

38

31-37

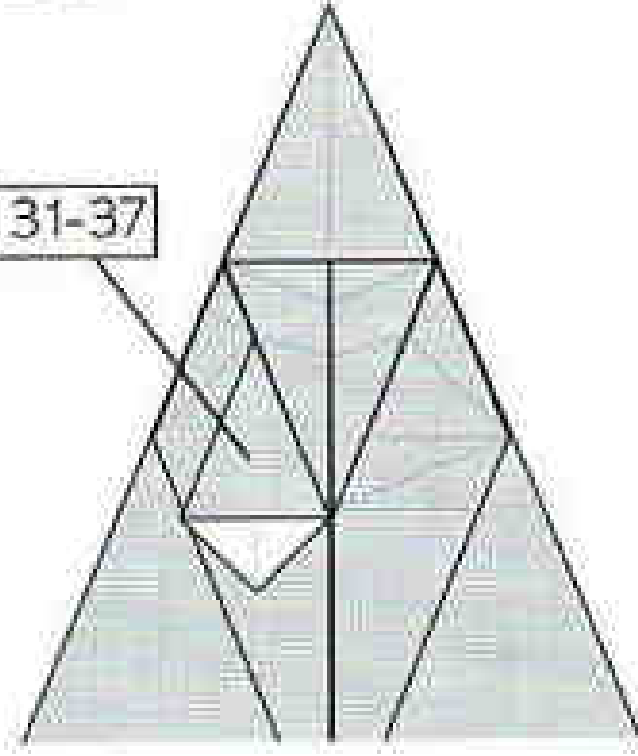

39

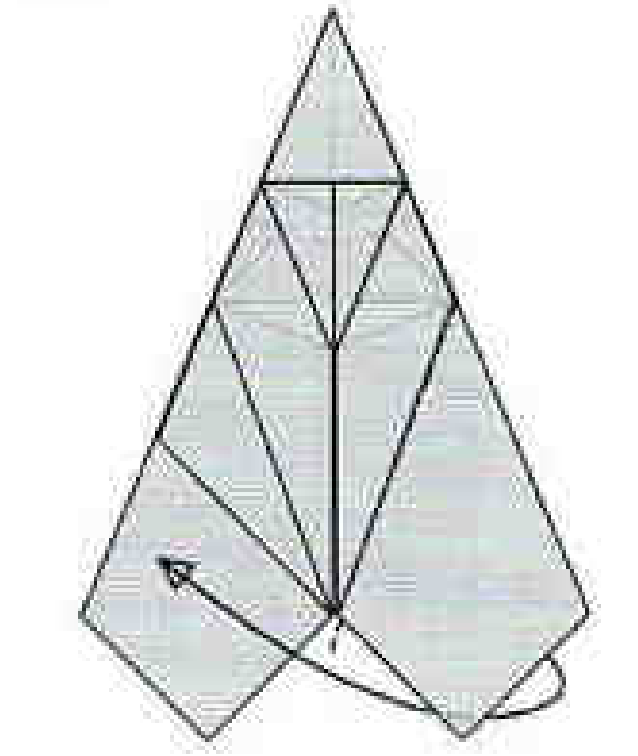

40

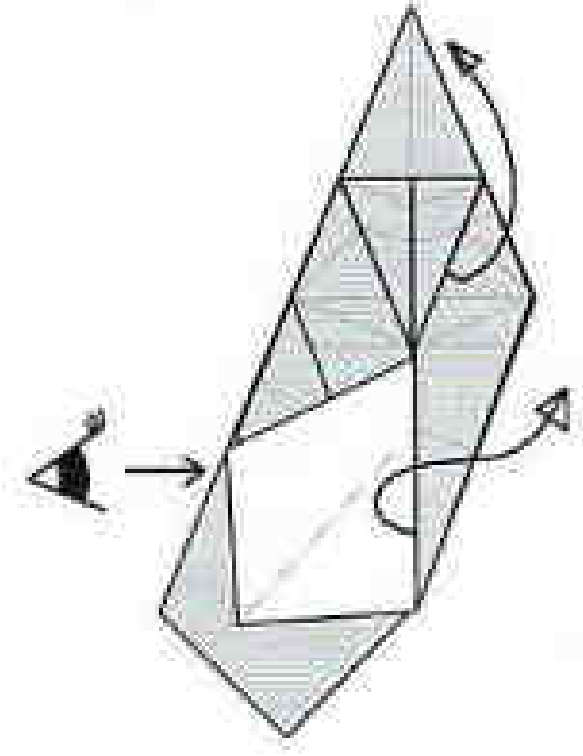

41

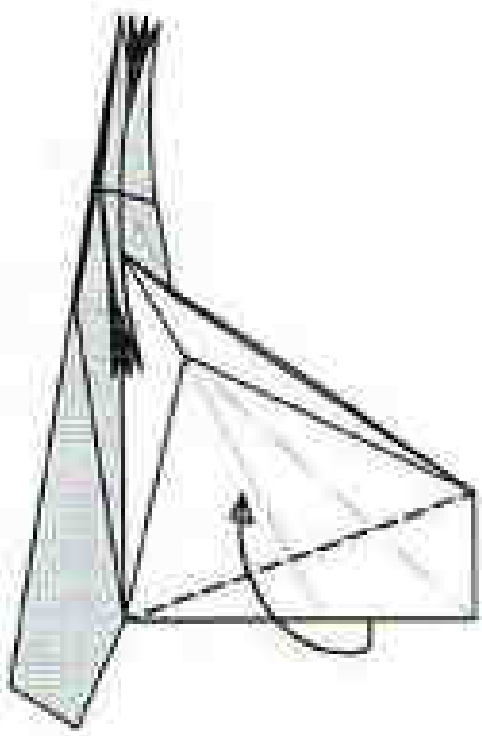

42

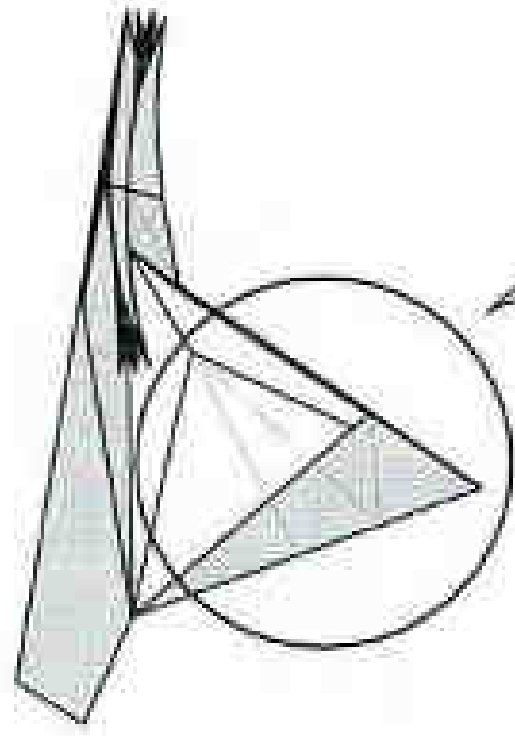

43

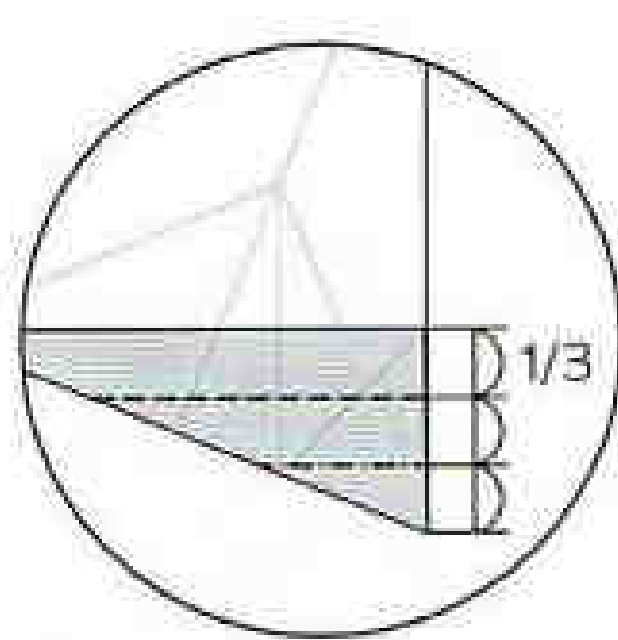

44

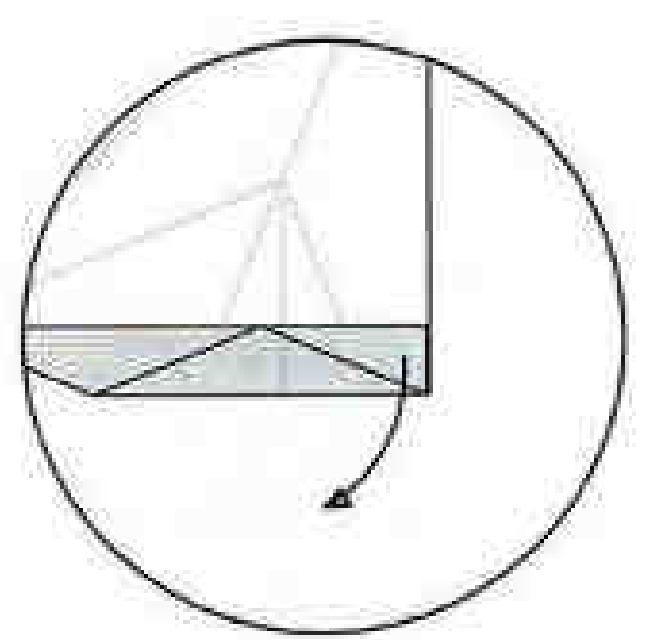

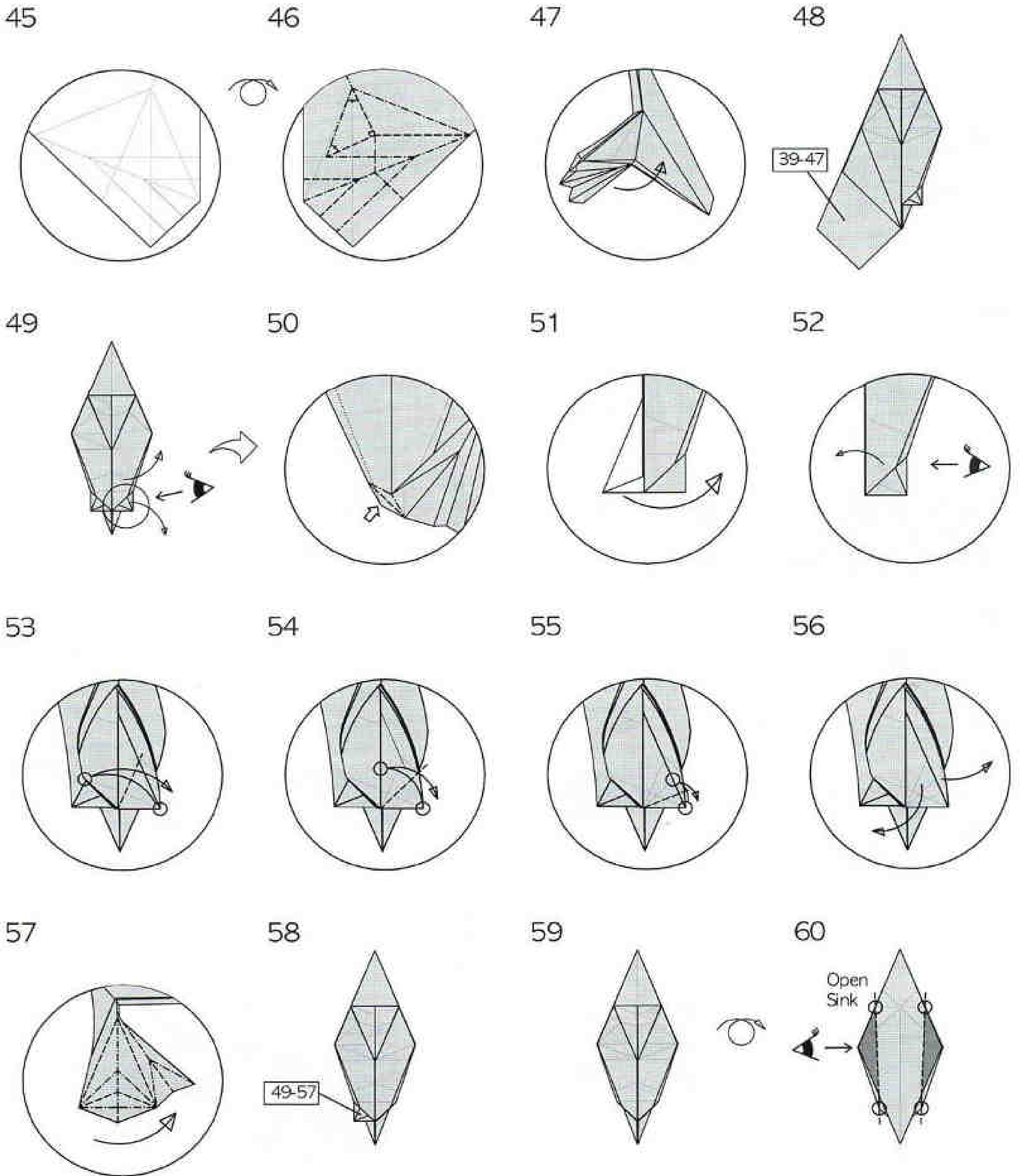

61

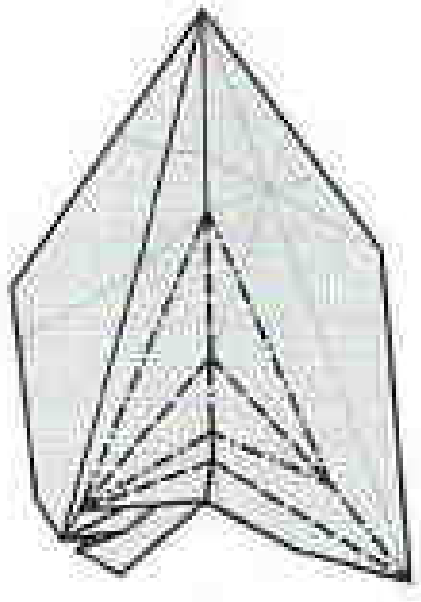

62

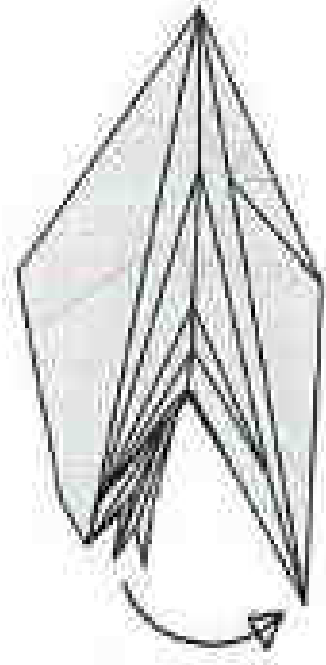

63

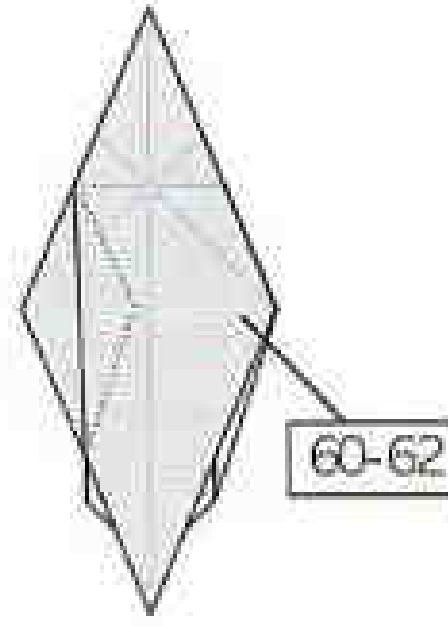

64



65



66

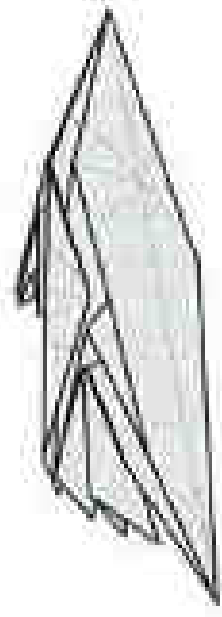

67



68

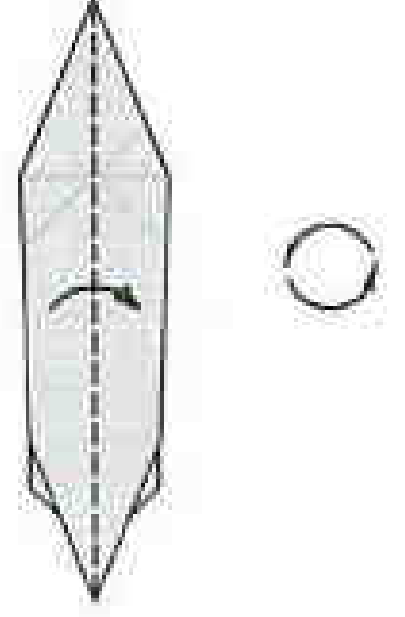

69

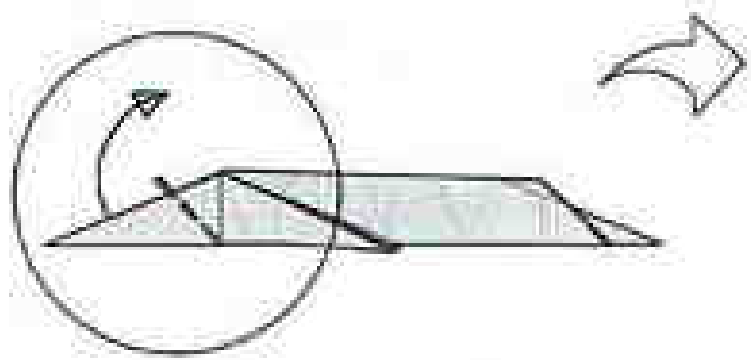

70

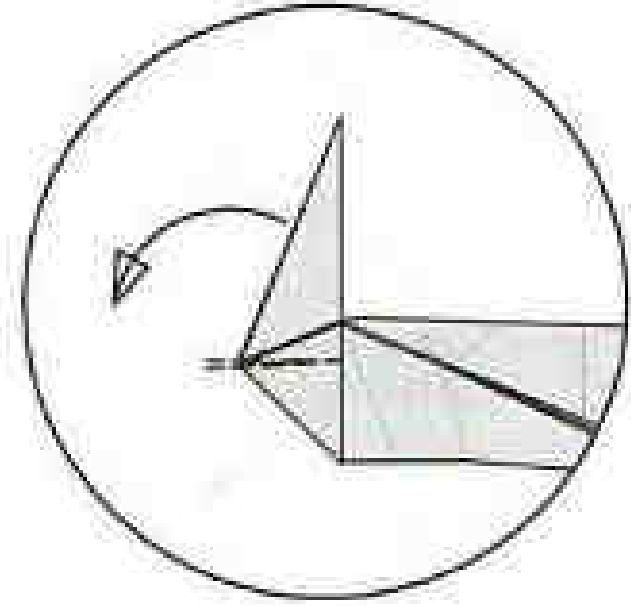

71

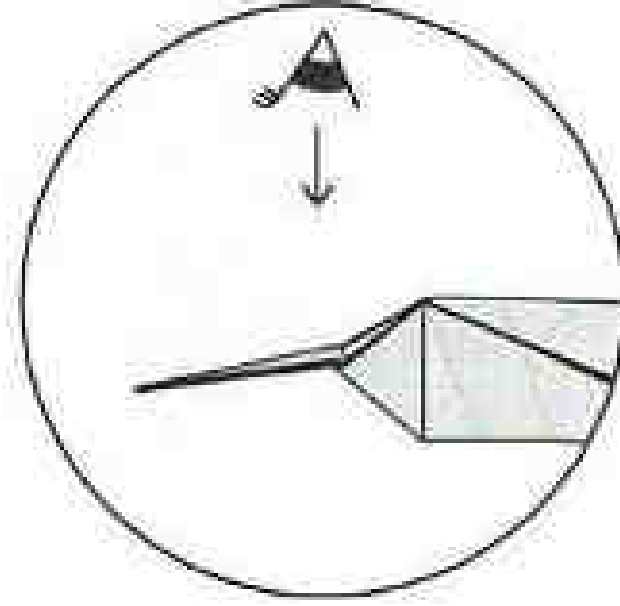

72



73

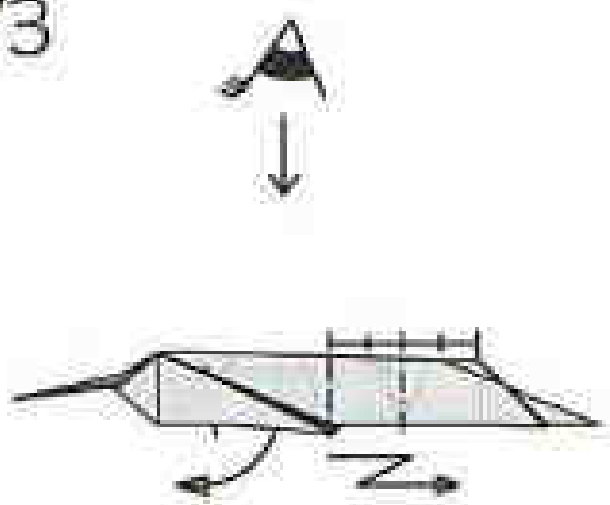

74

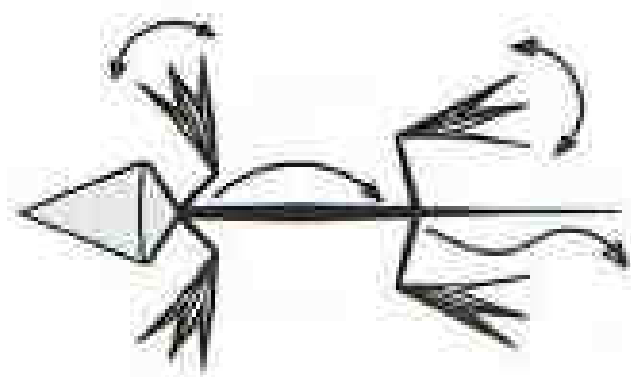

75

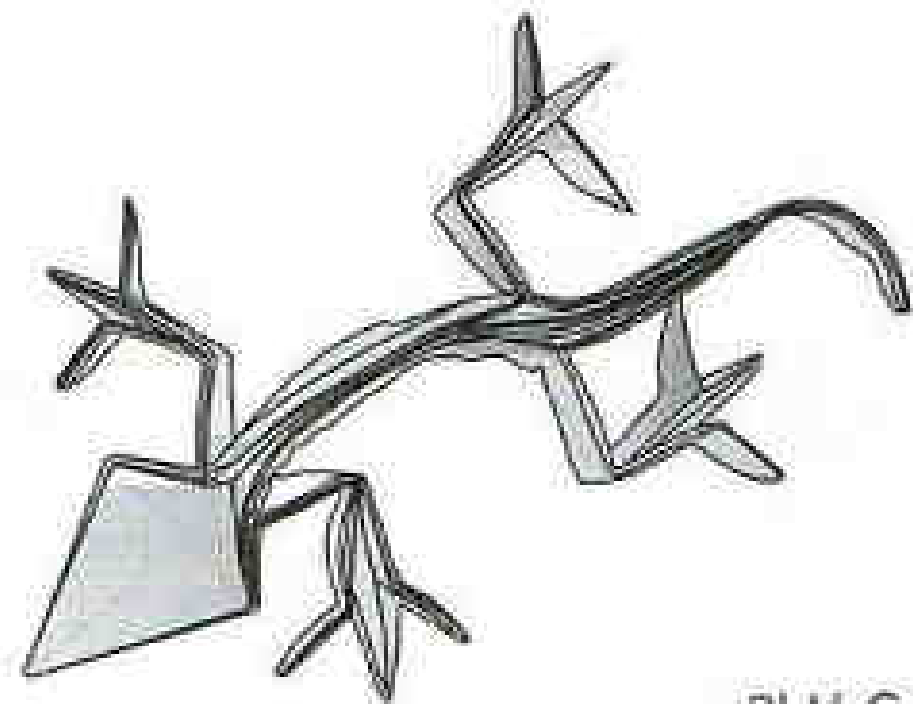

완성 Complete

말 (Horse)

창작가 : 응웬 흥 쩡 (Nguyen Hung Cuong)

포토다이아그램 : 김진우 (Kim Jin Woo)

다이아그램 : 김영민 (Kim Young Min)

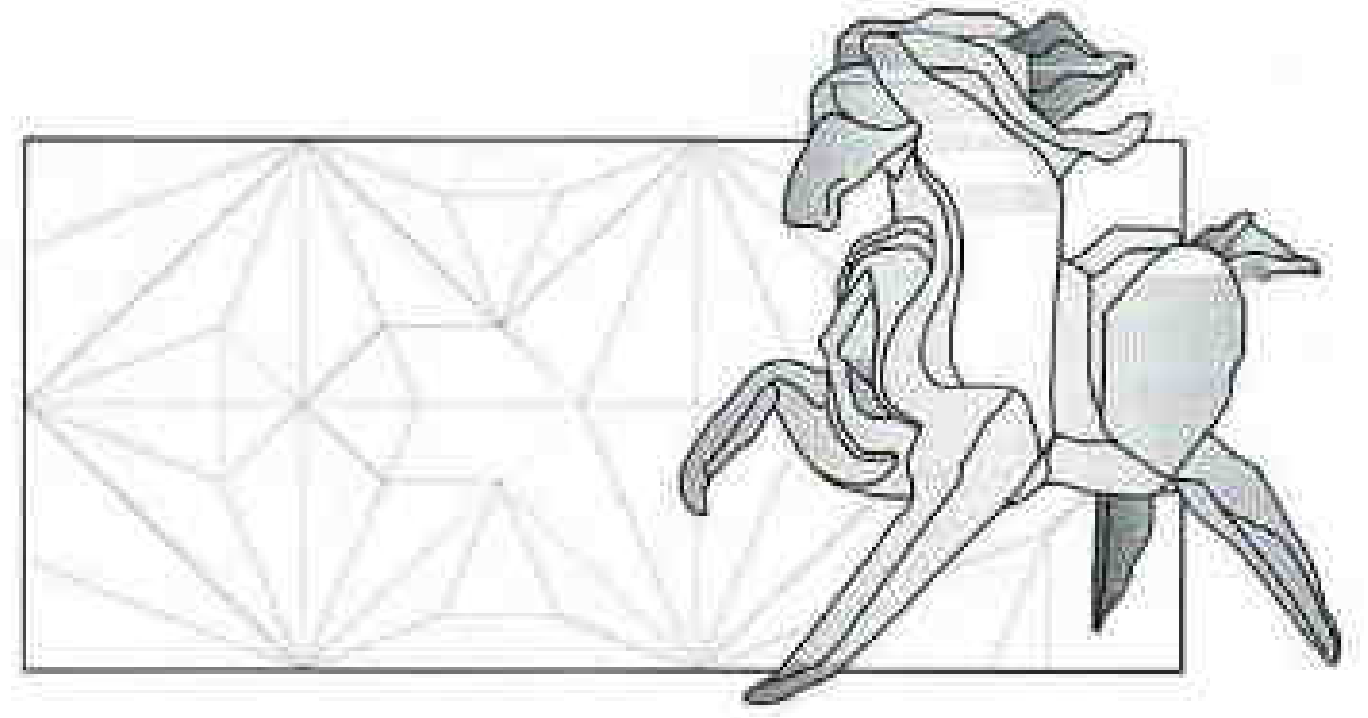

말은 134 x 65 mm 크기의 베트남 지폐로 접었으며, 한국 지폐로는 5000원권 지폐가 가장 근접한 크기입니다. (142 x 68 mm)

- 너무 비싼 돈으로 접지는 마시길 바랍니다. 27/13 비율의 일반 종이로도 접을 수 있습니다.

The horse is from a Vietnamese Banknote, which dimensions is 134 x 65cm, very close to the 5000 won (142 x 68 mm)

- I hope it's not too expensive. Or people can fold it with regular paper with ratio of 27/13.

1



2

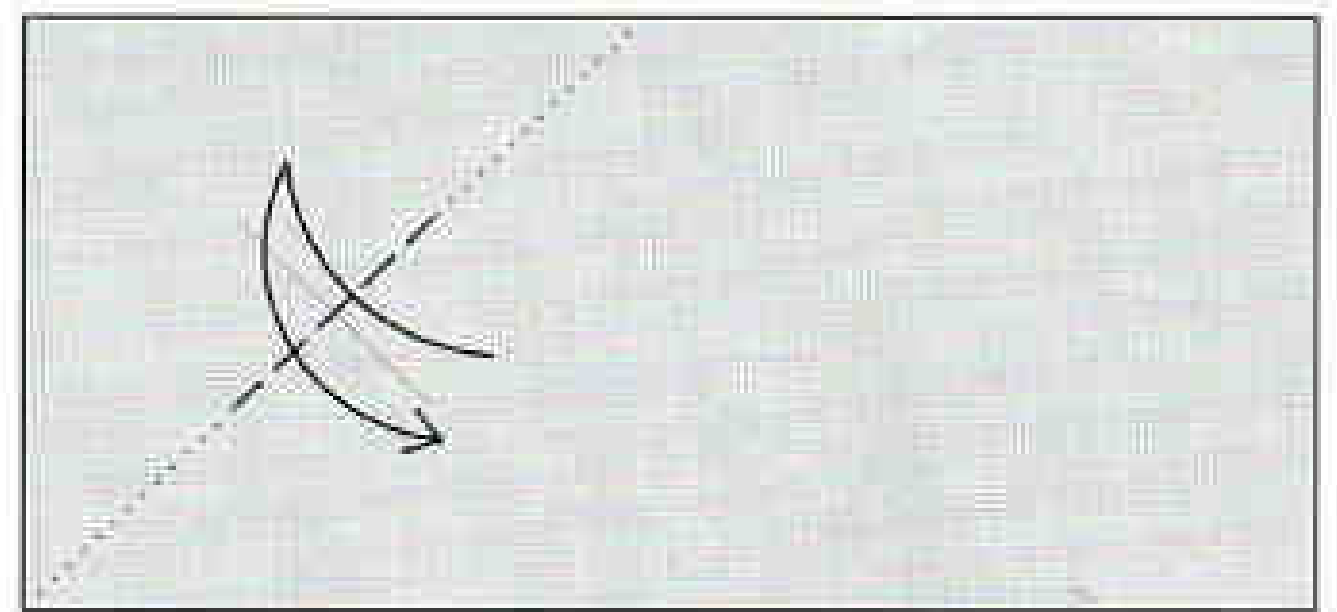

3

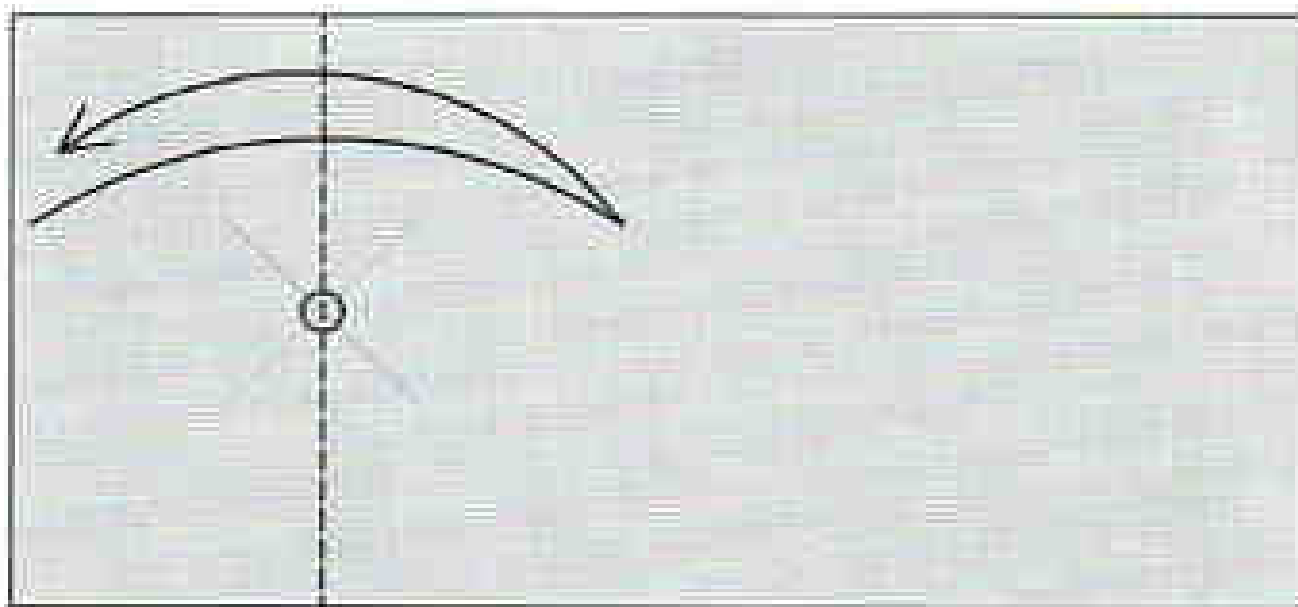

4

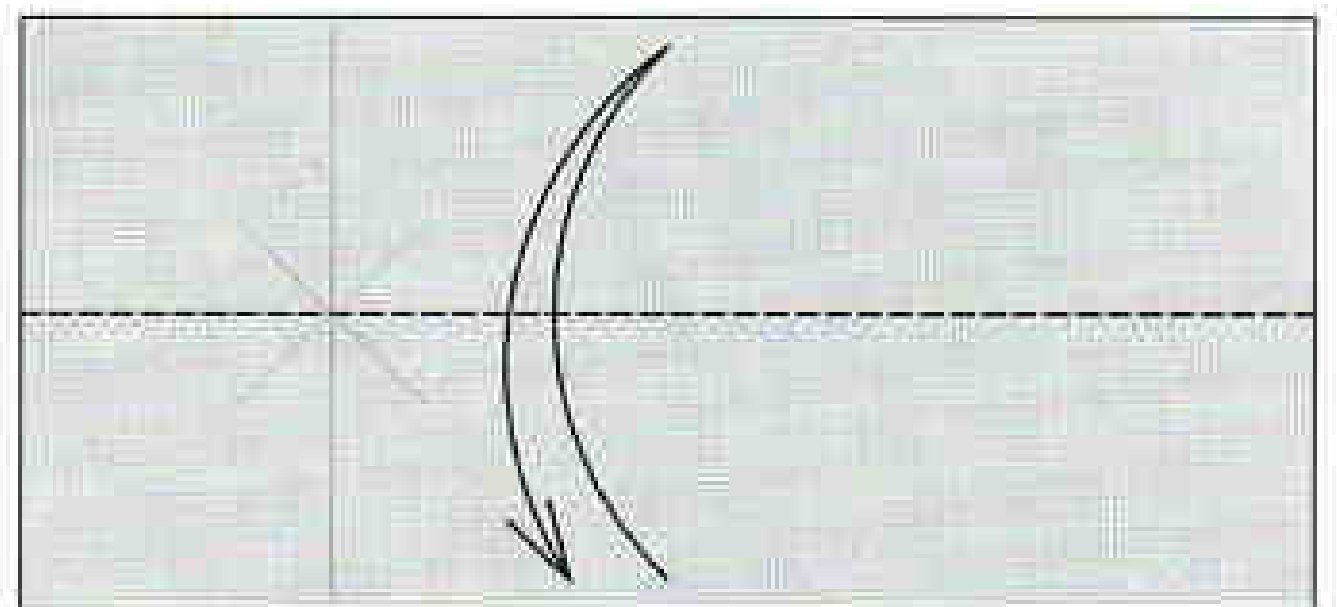

5

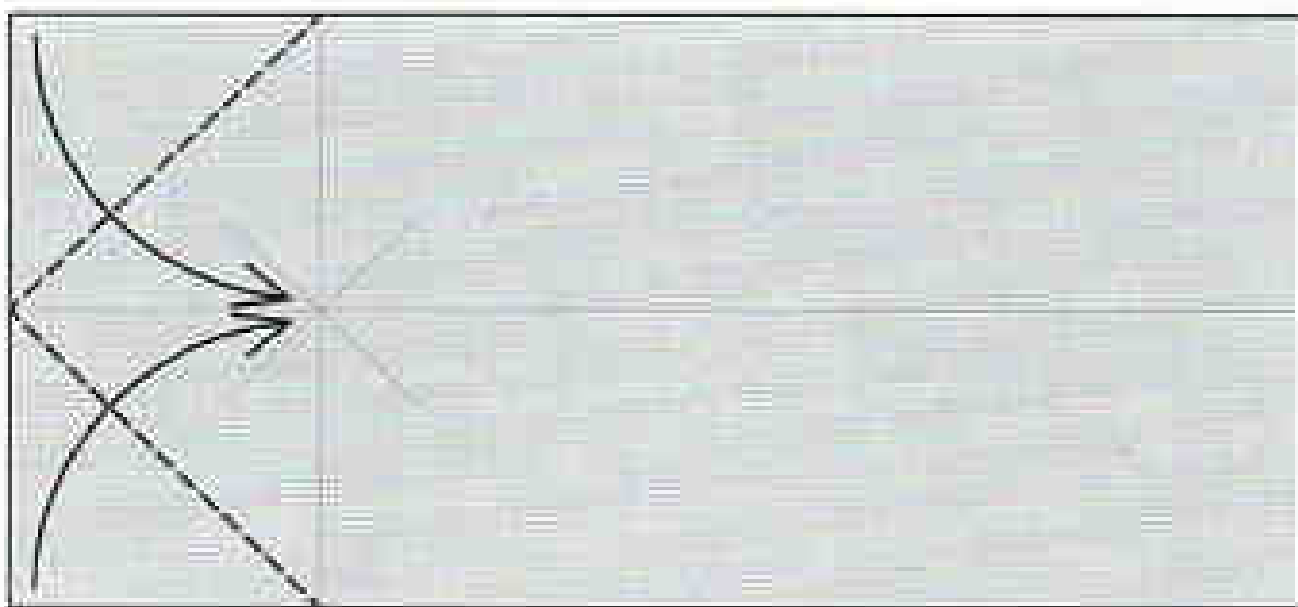

6



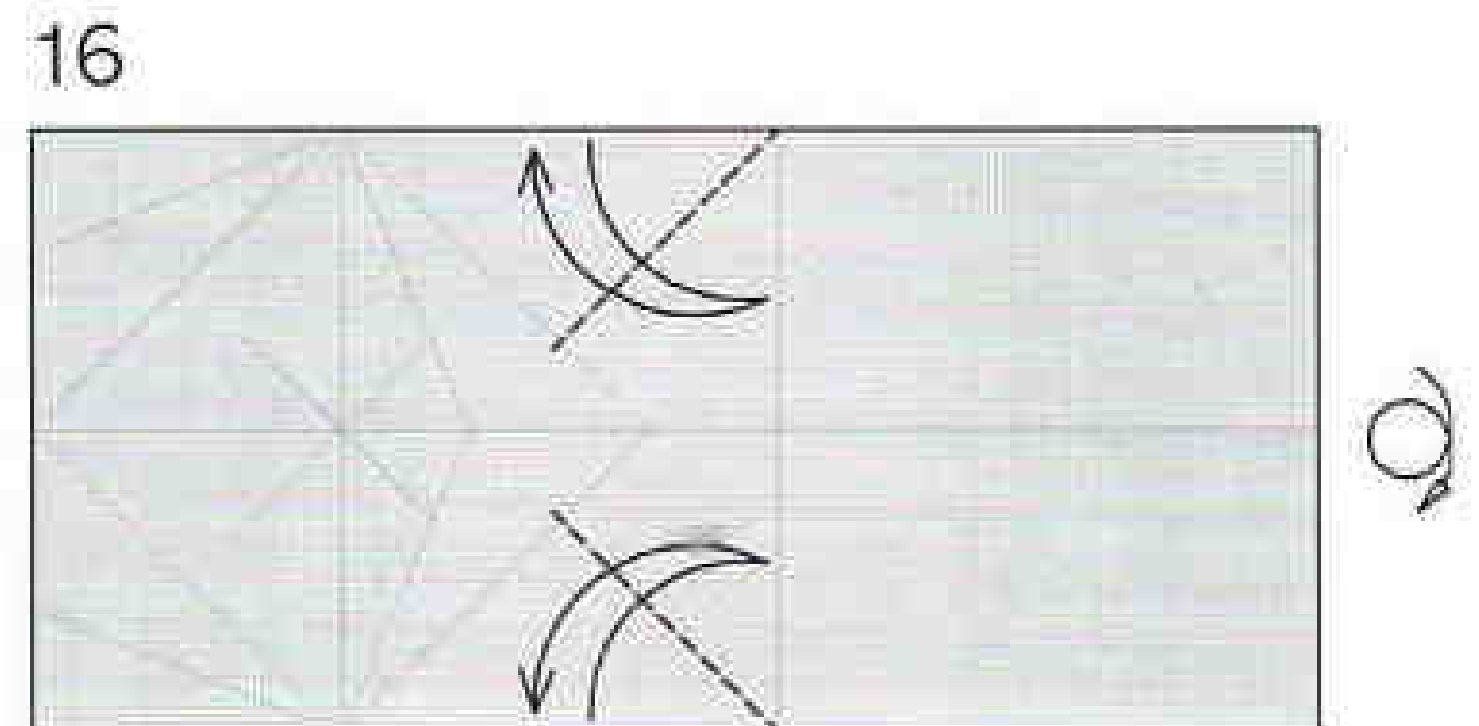
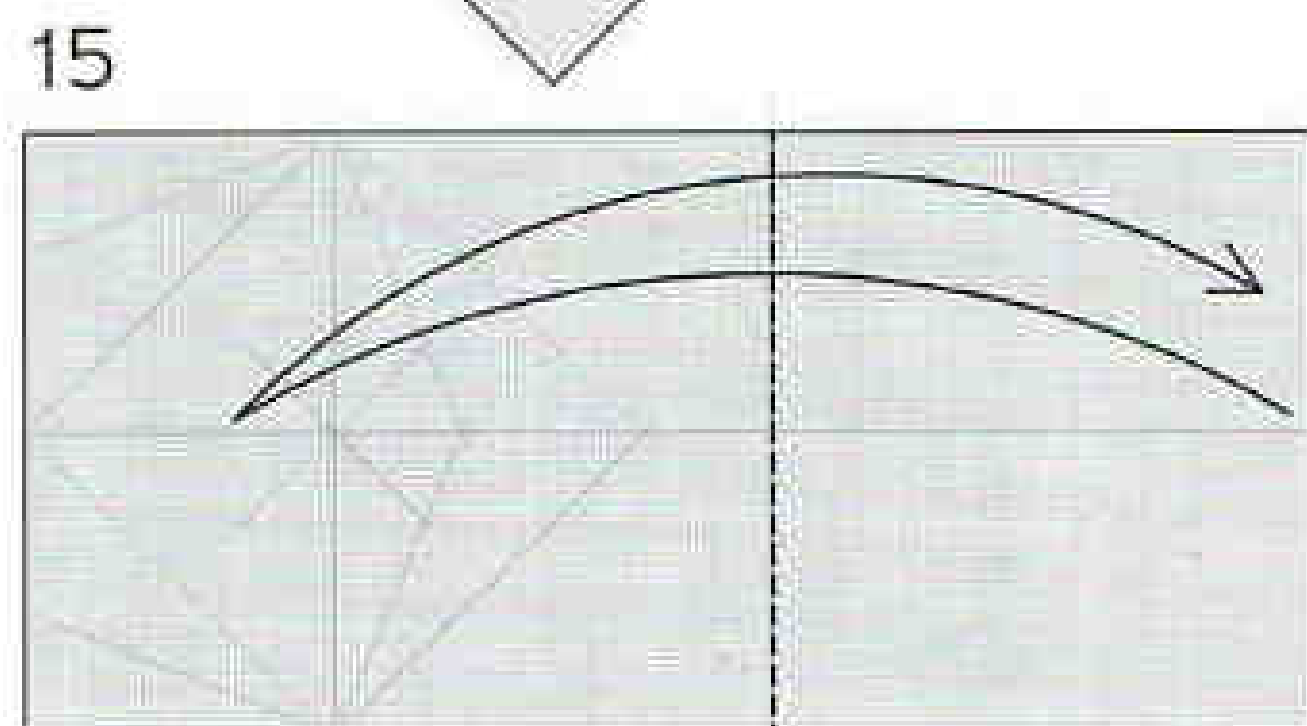
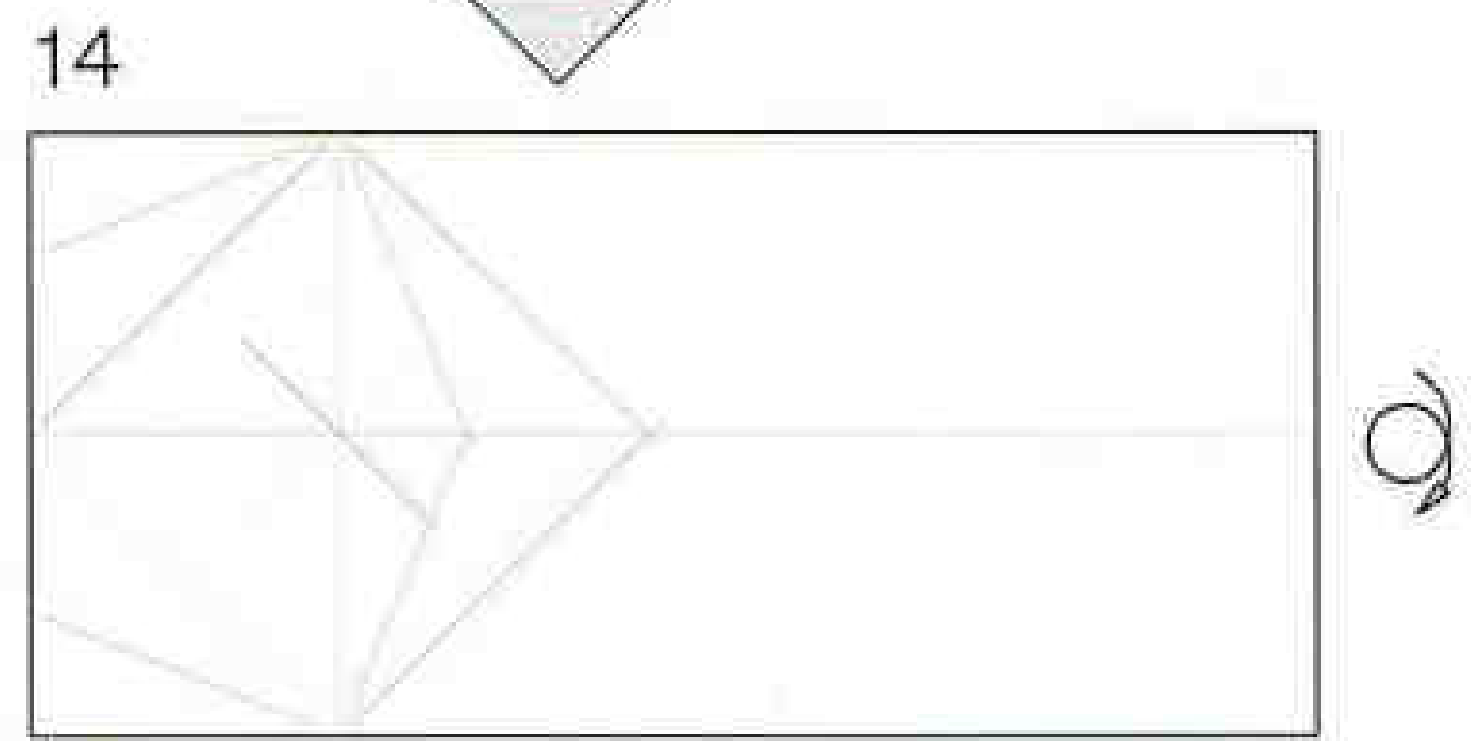
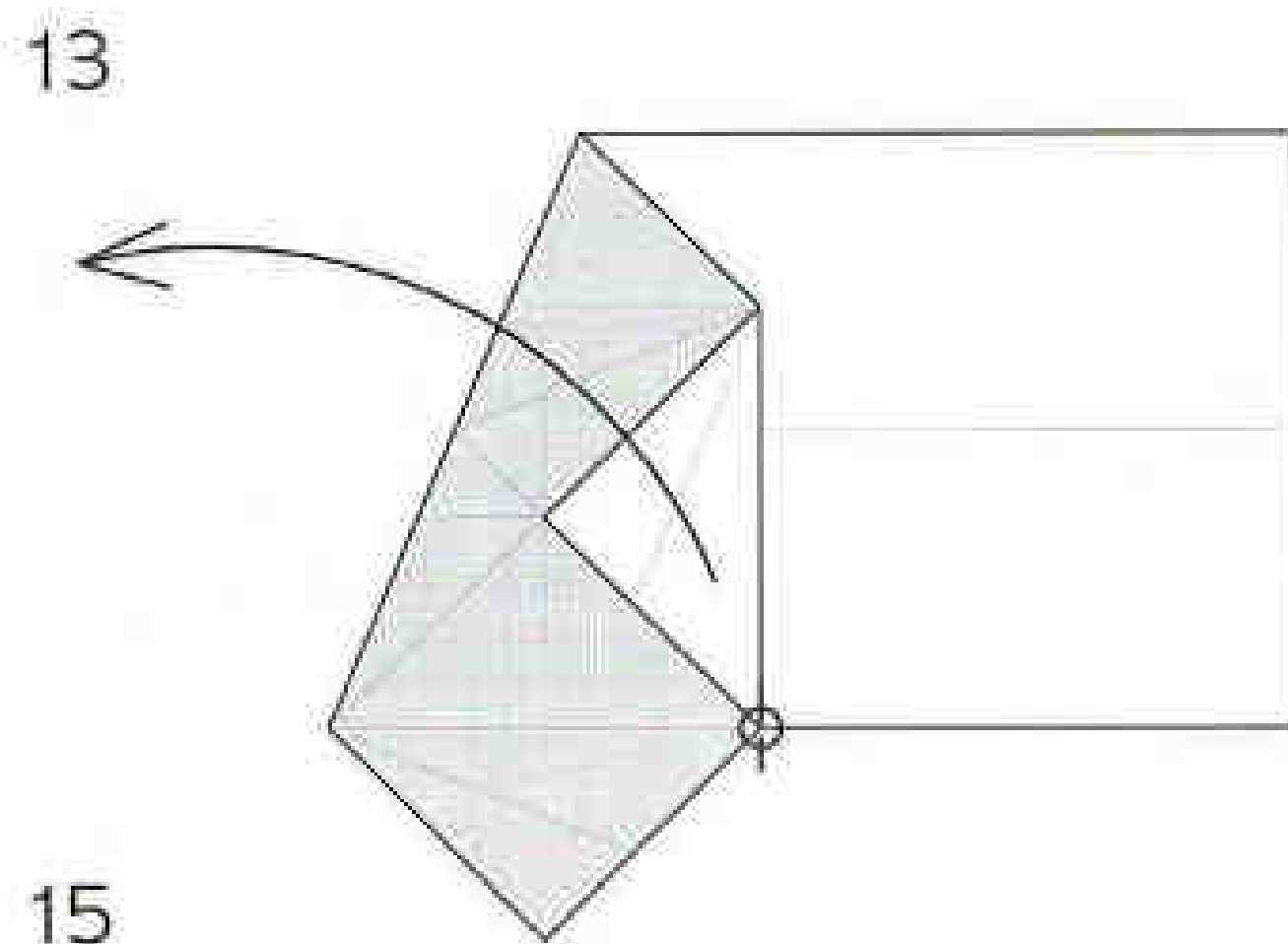
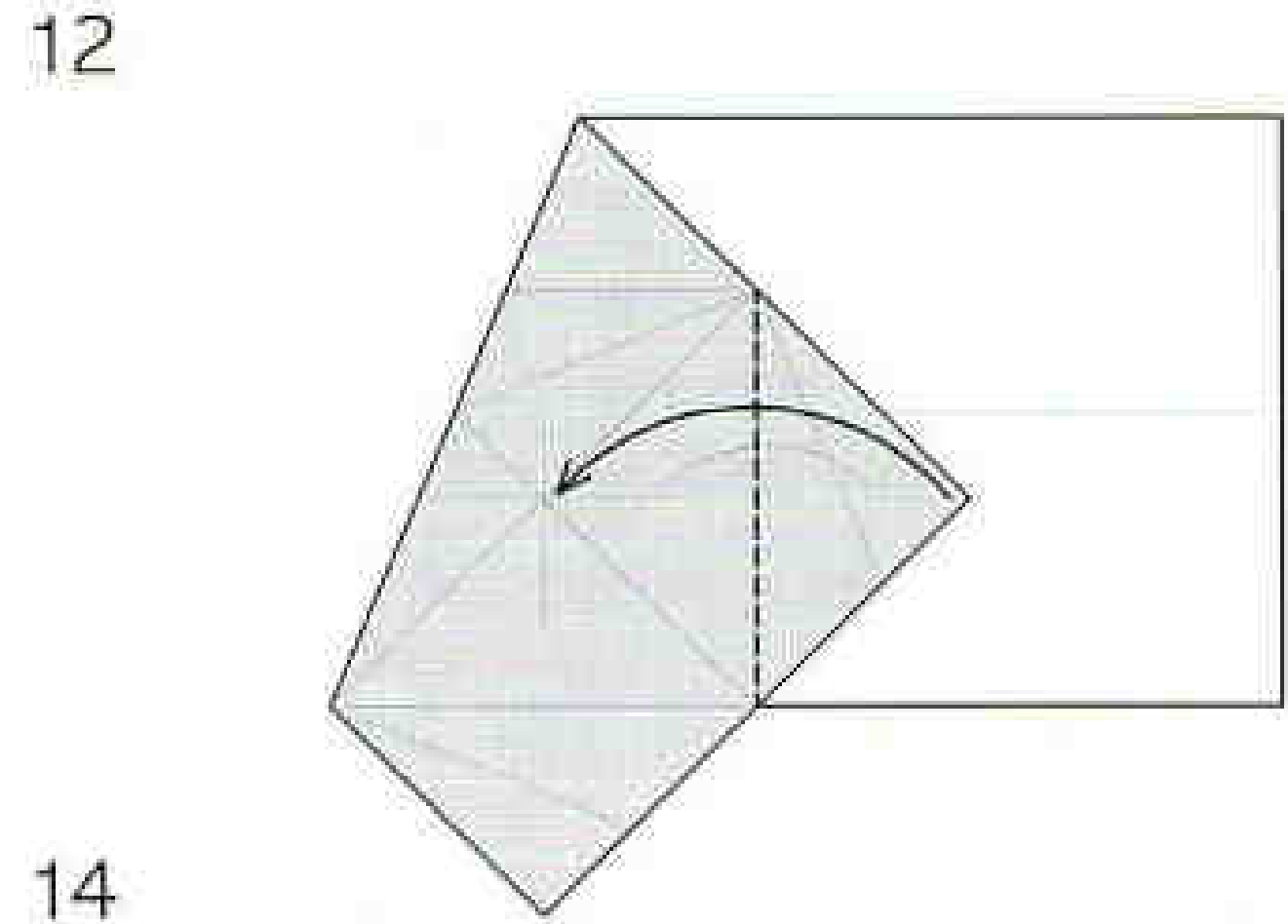
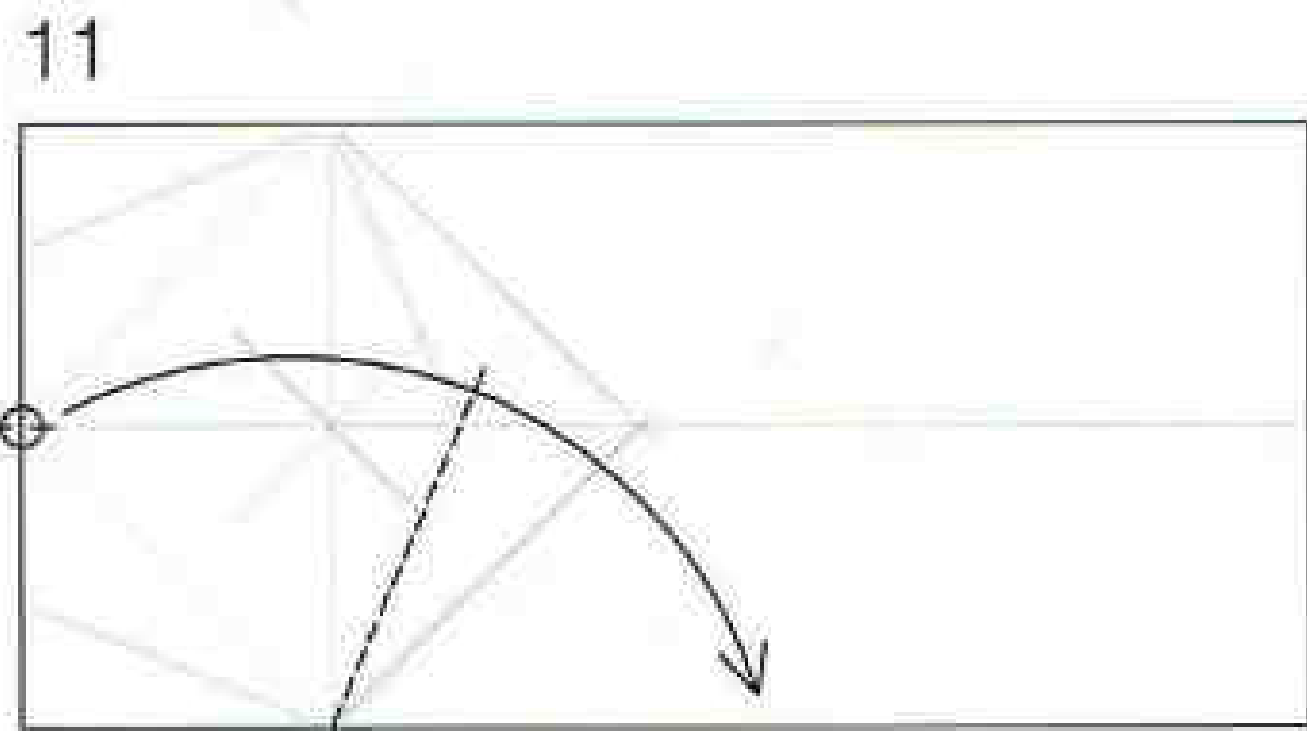
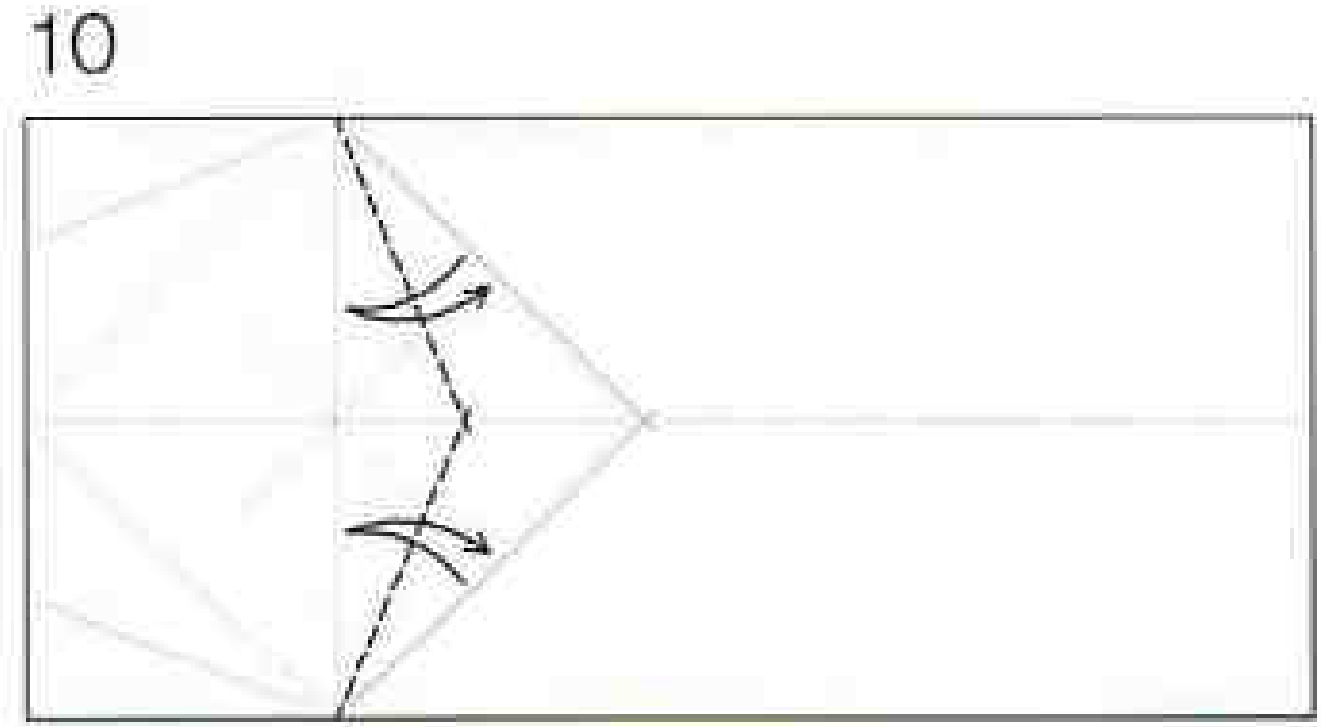
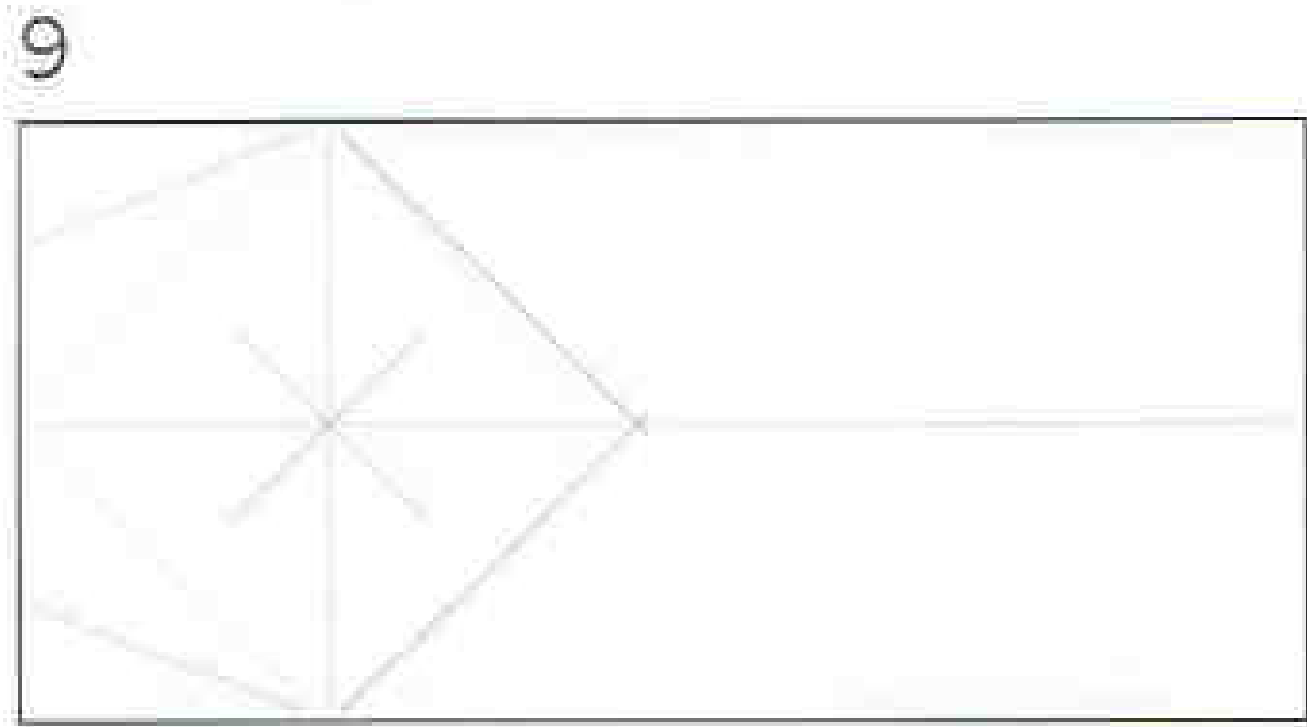
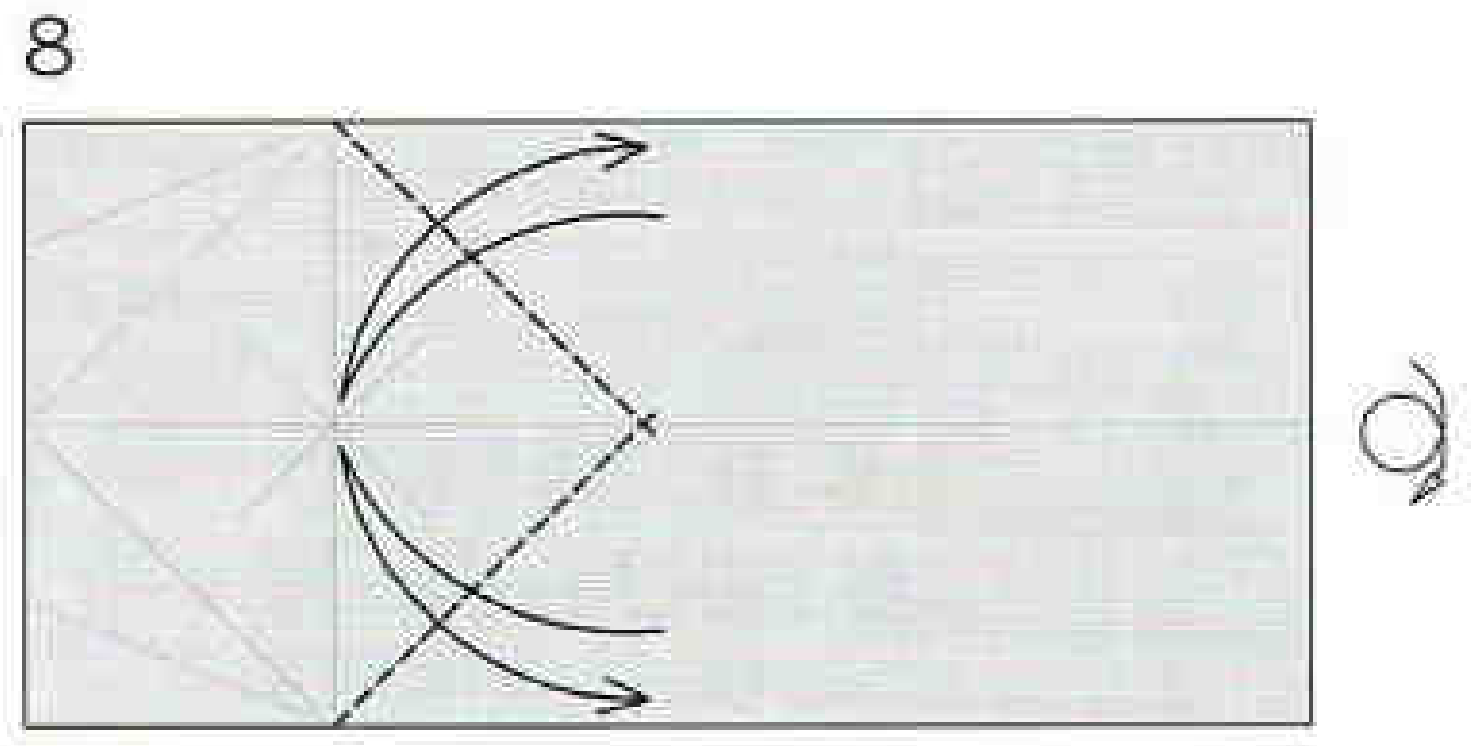
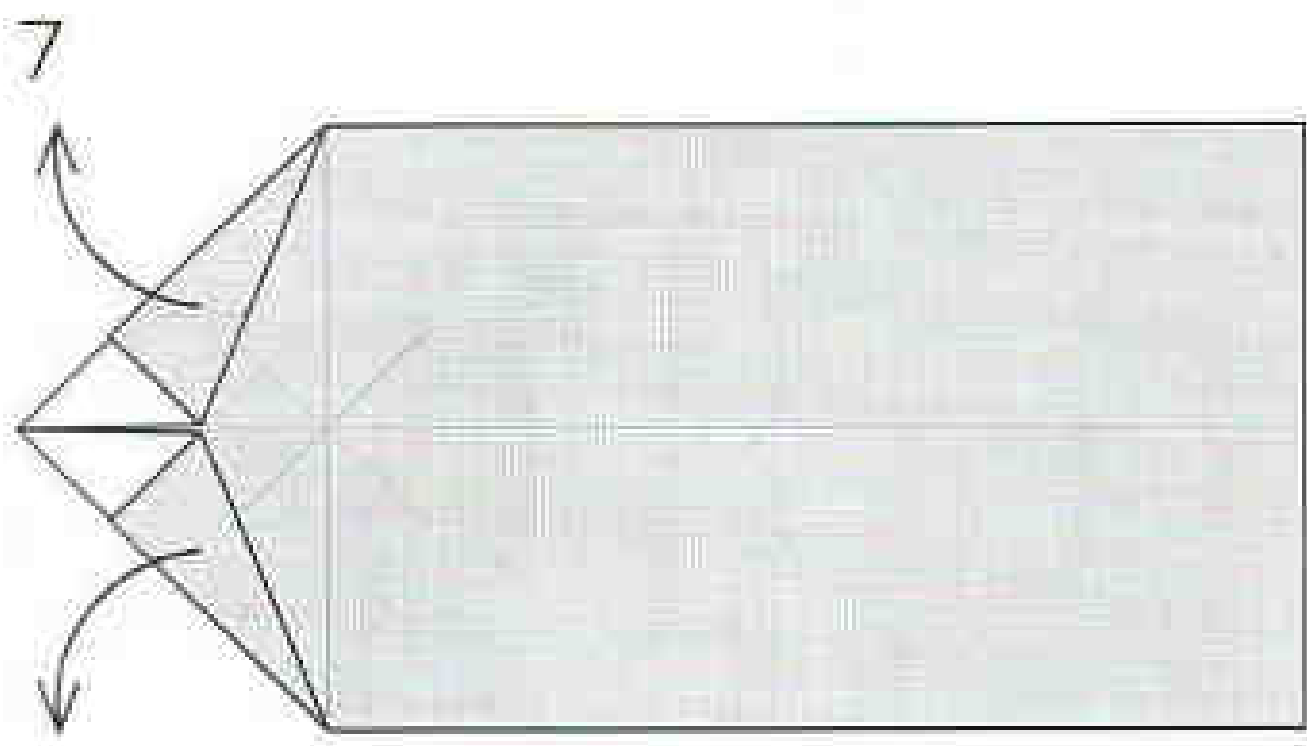

17

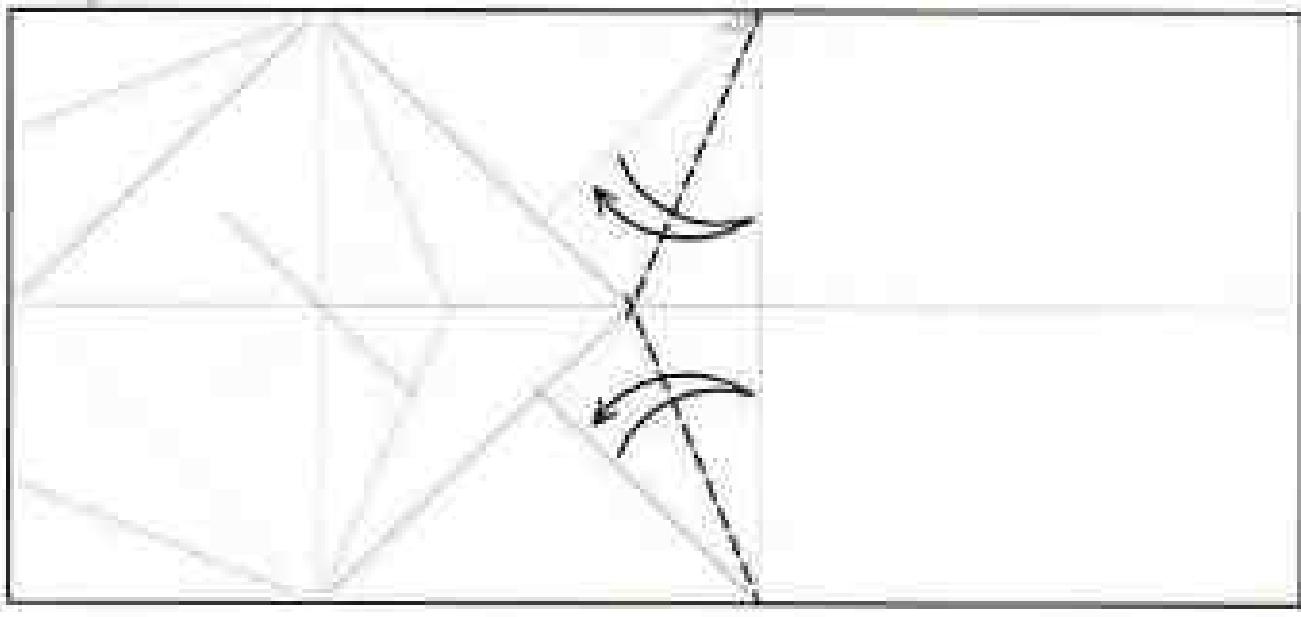

18

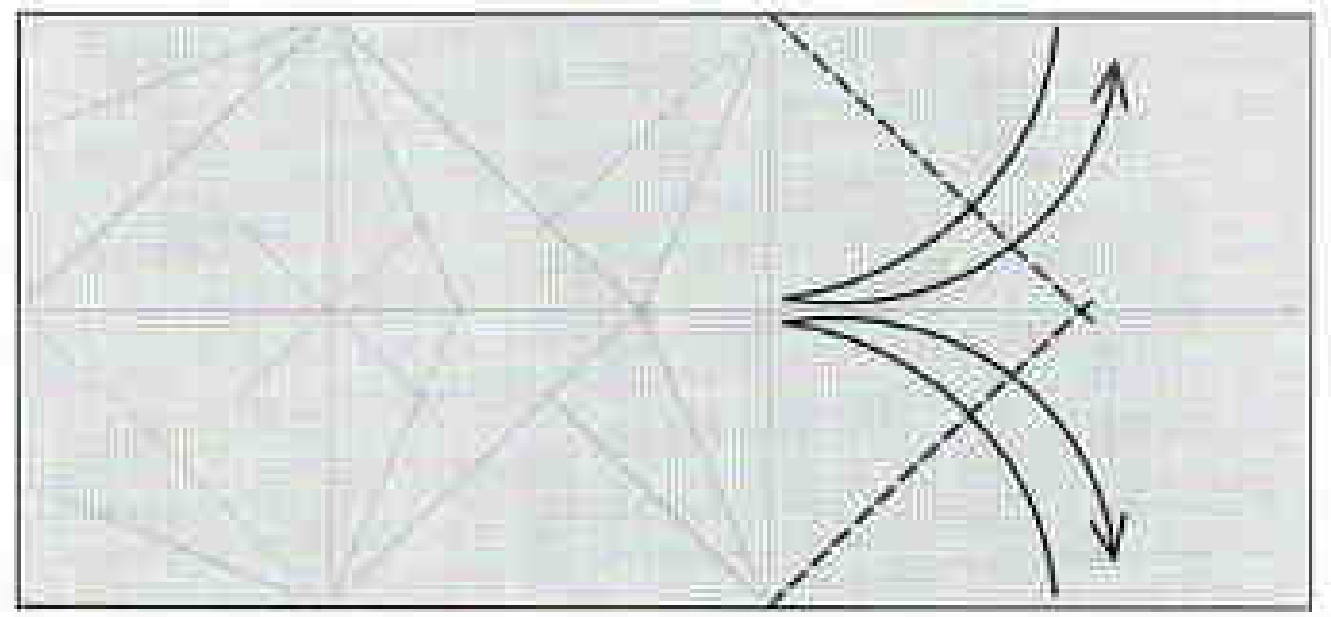

19

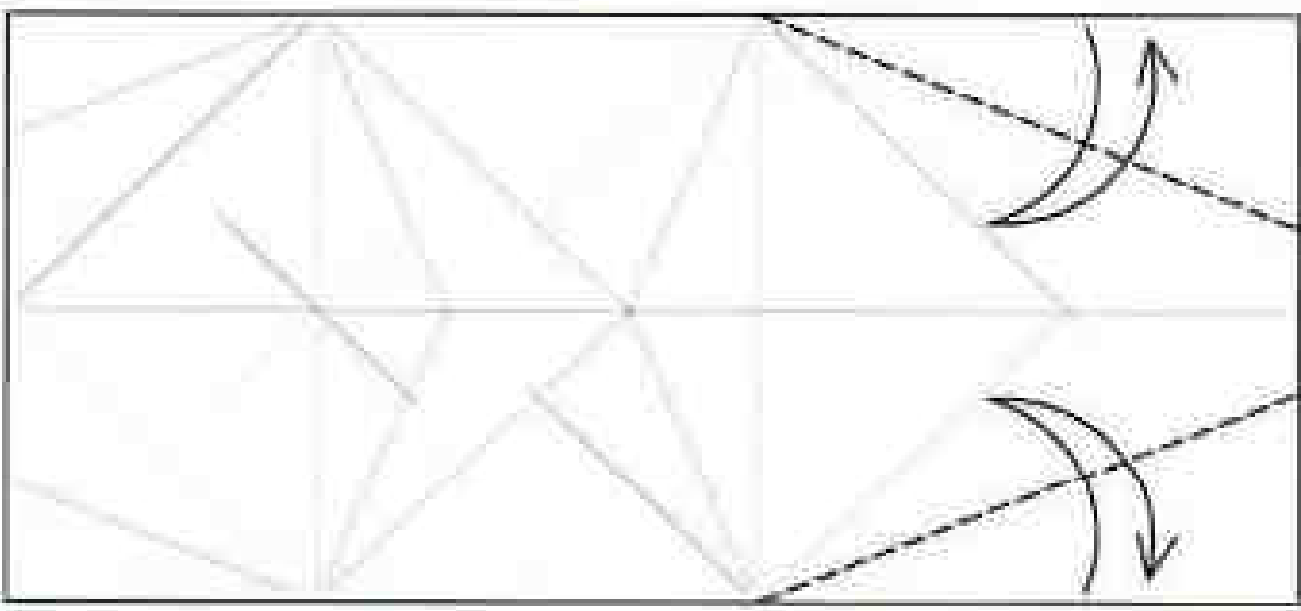

20

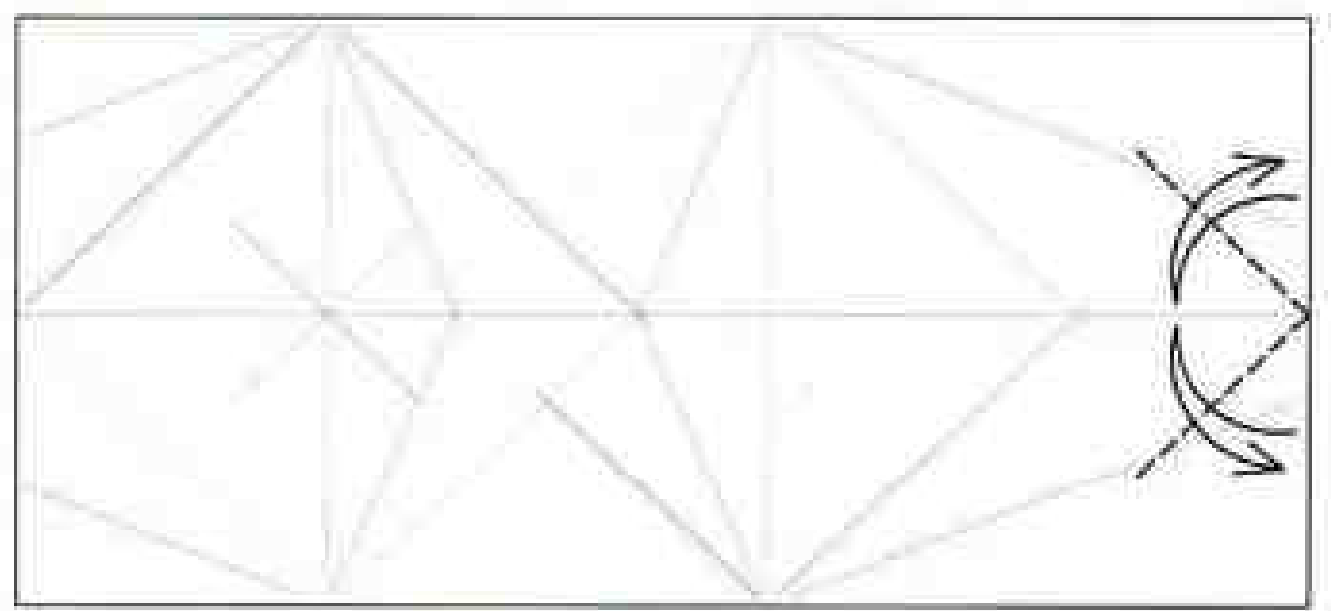

21

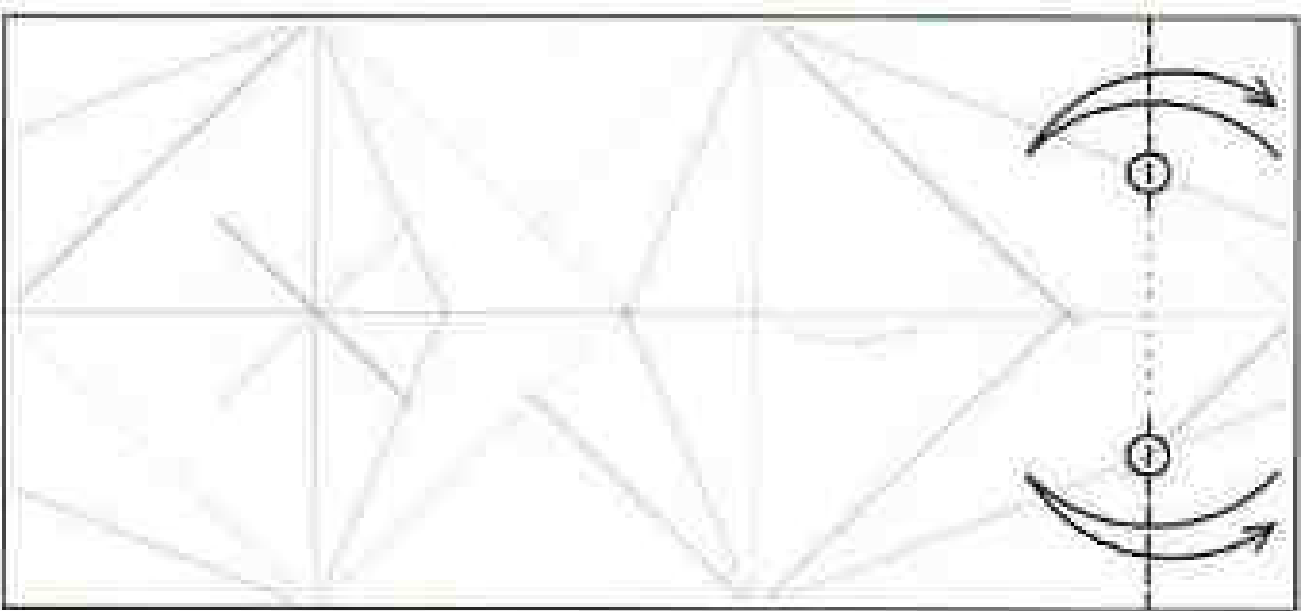

22

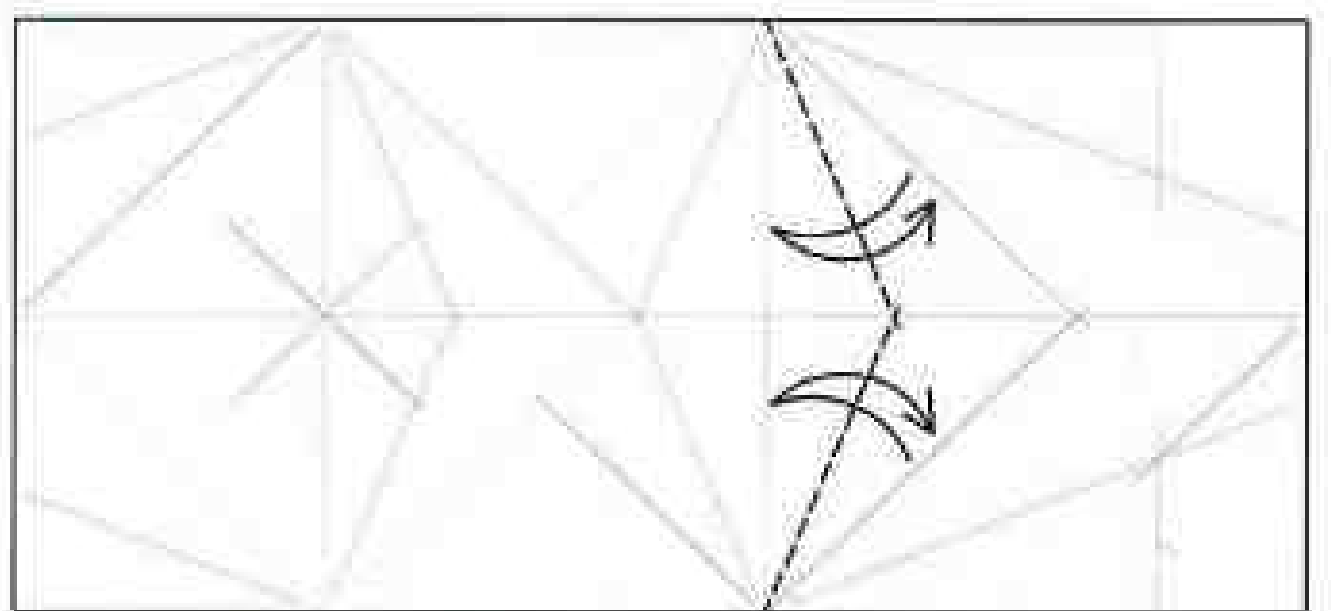

23

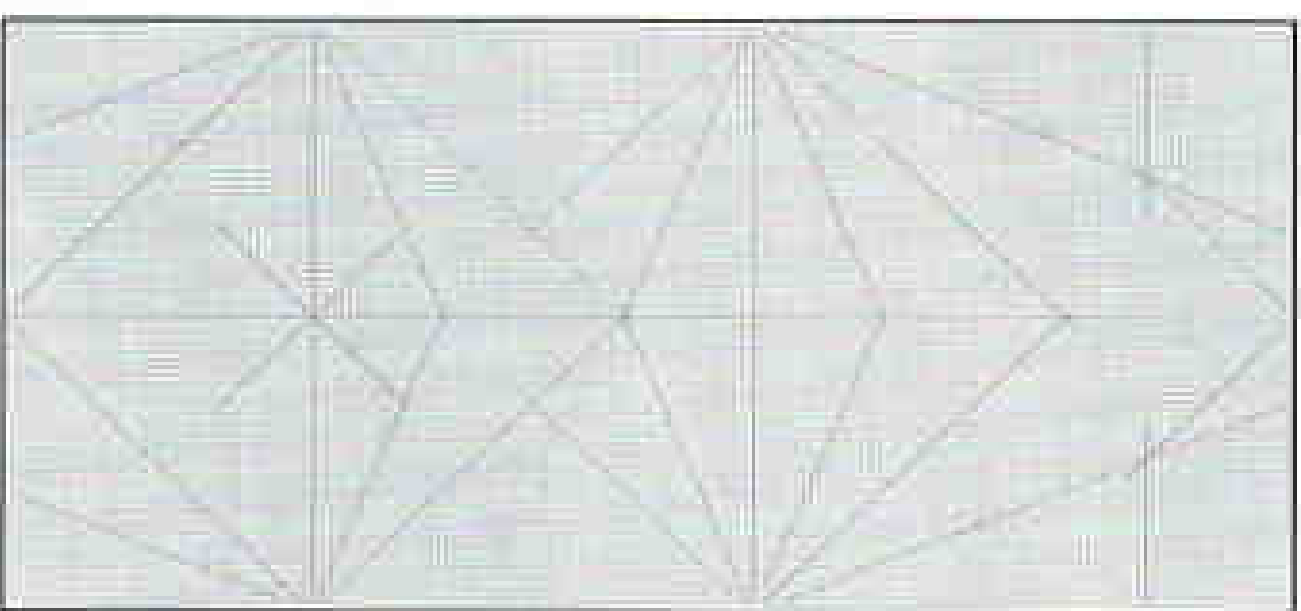

24

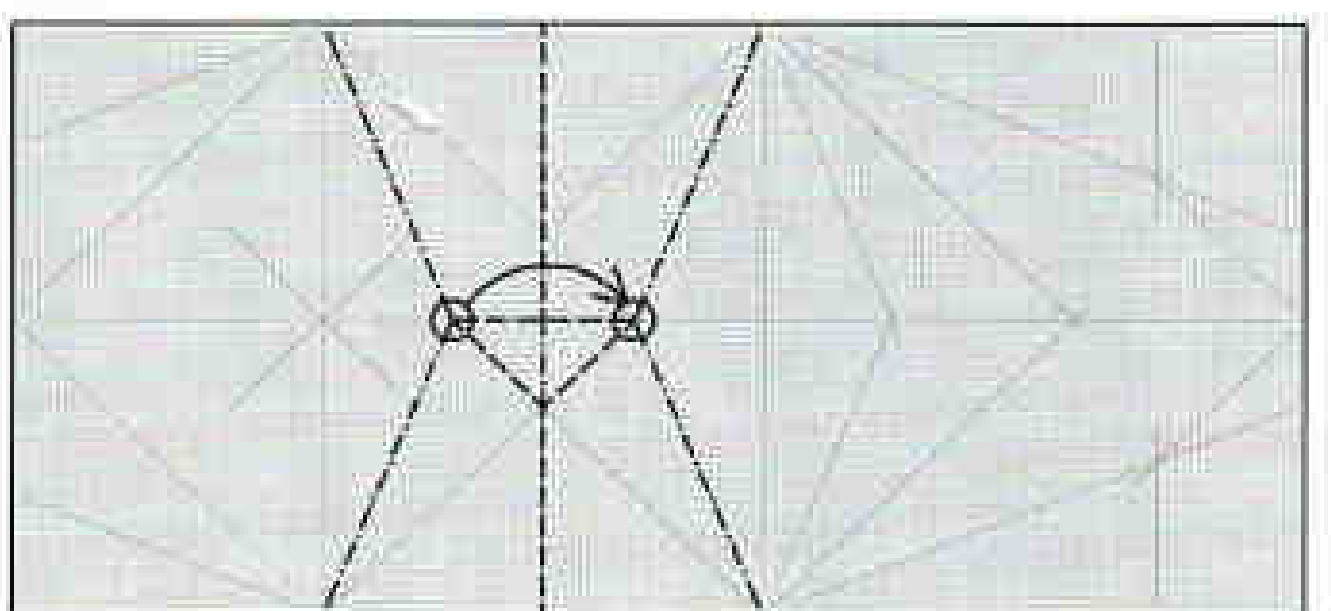

25

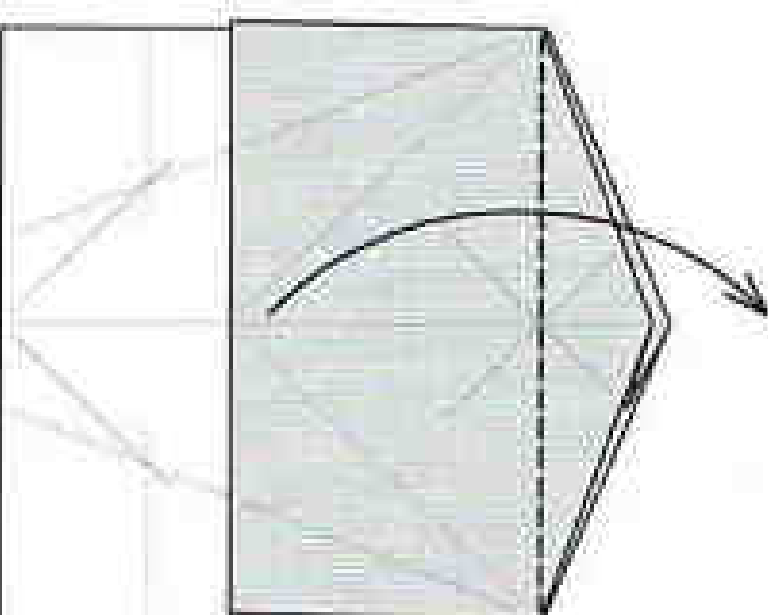

26

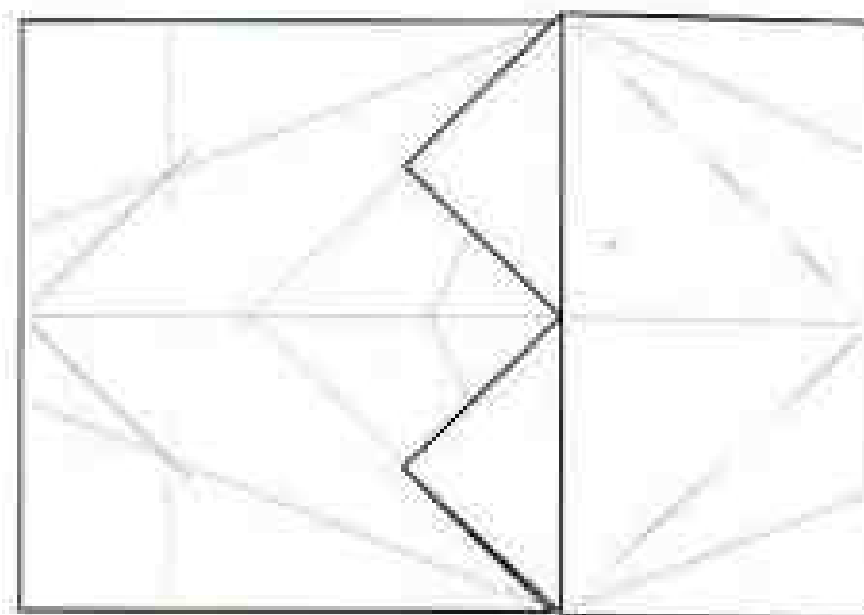

27

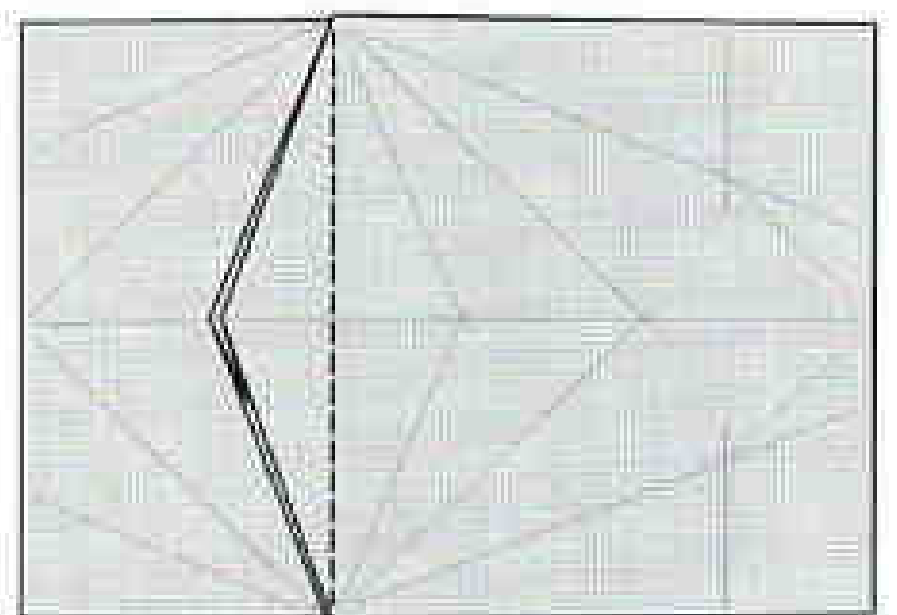

28

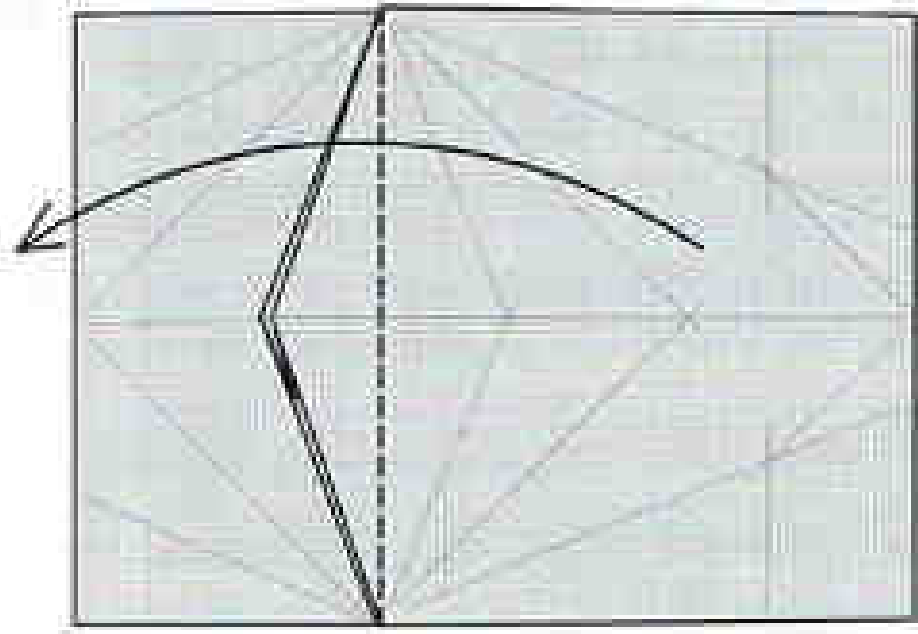

29

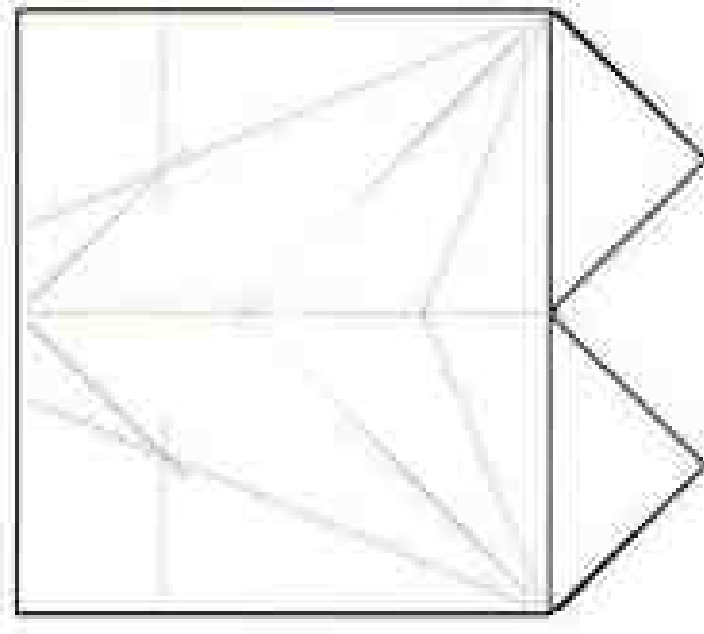

30

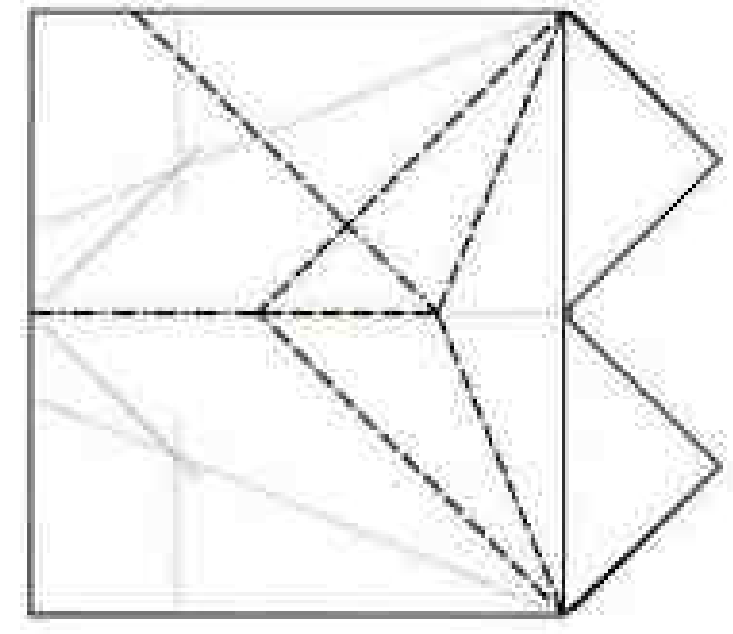

31

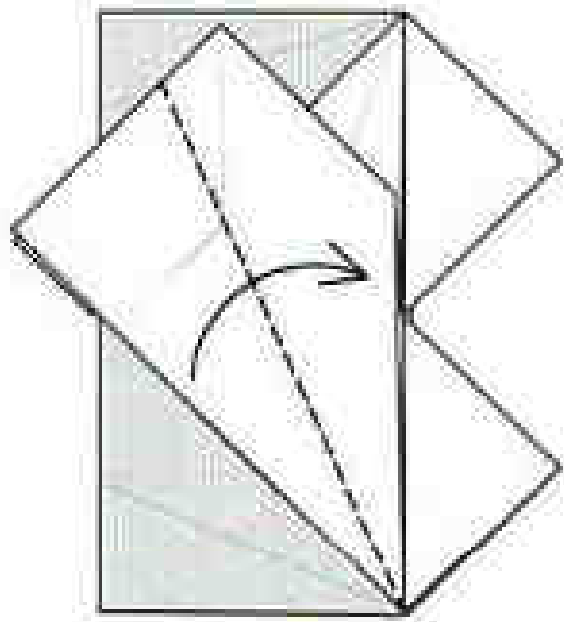

32

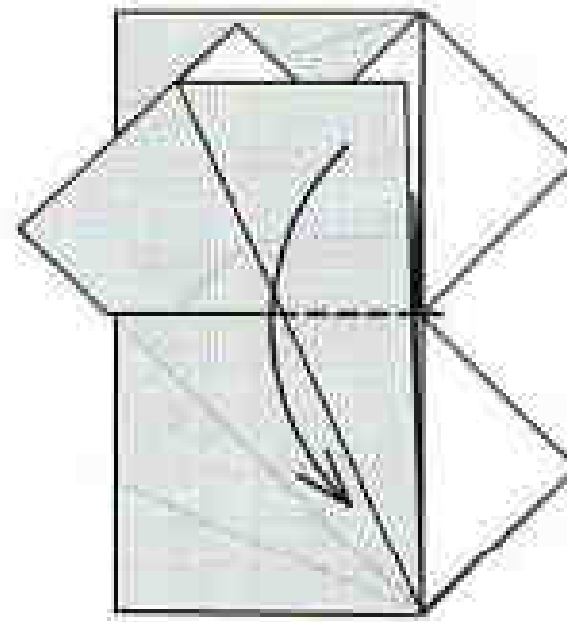

33

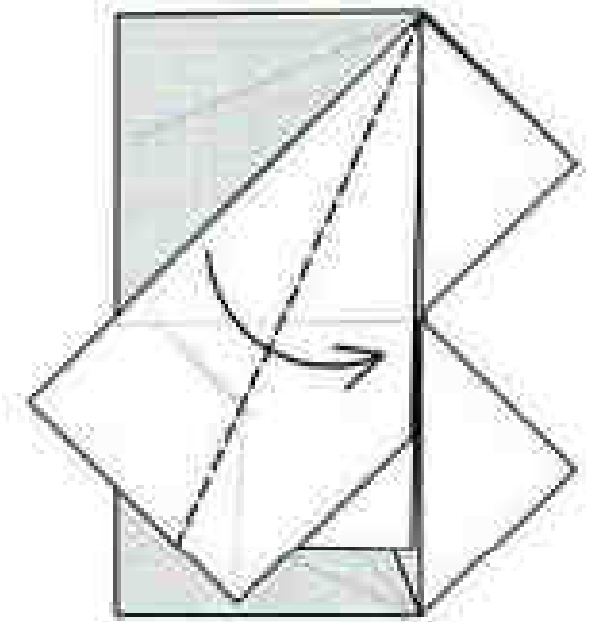

34

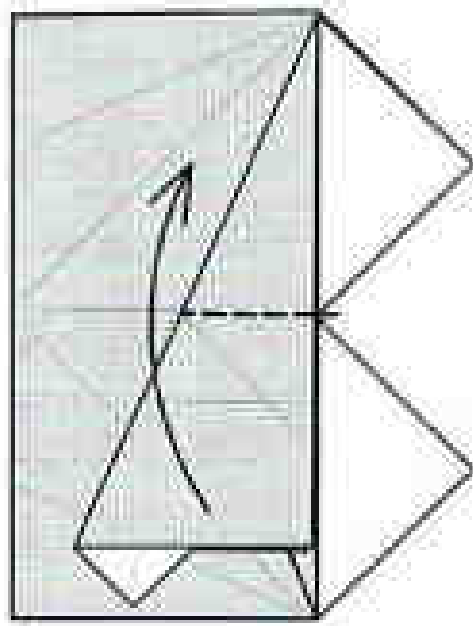

35

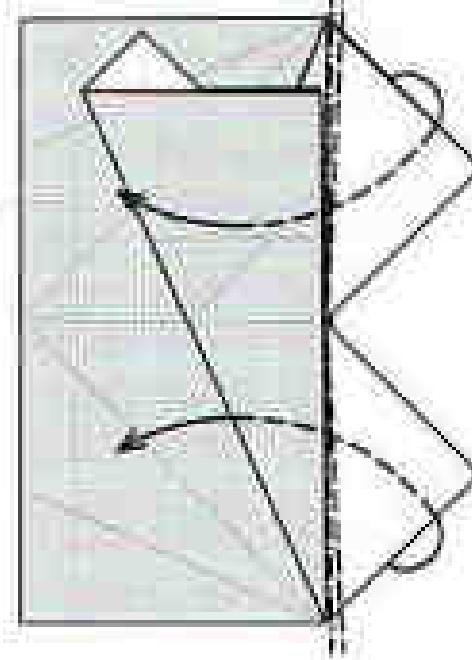

36

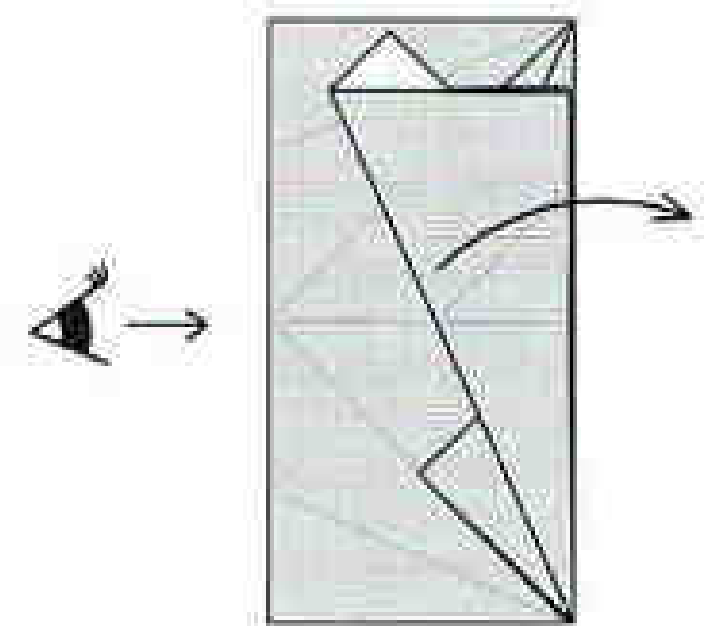

37

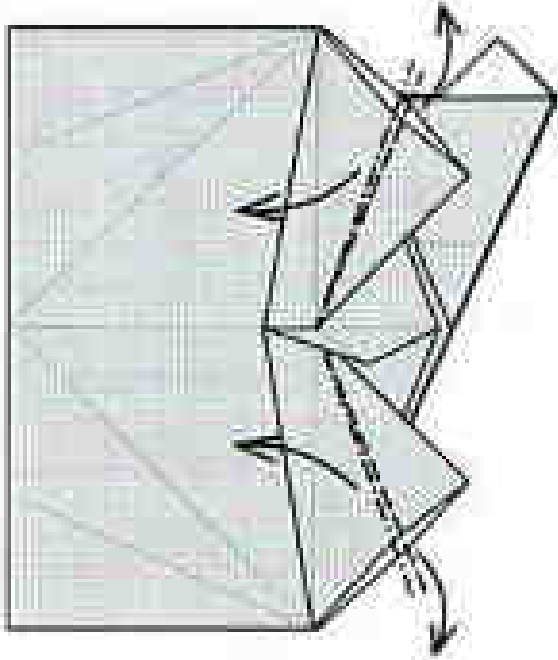

38

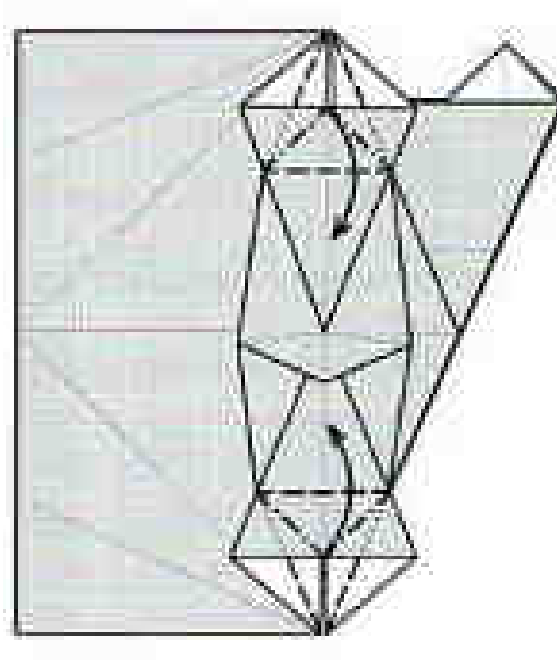

39

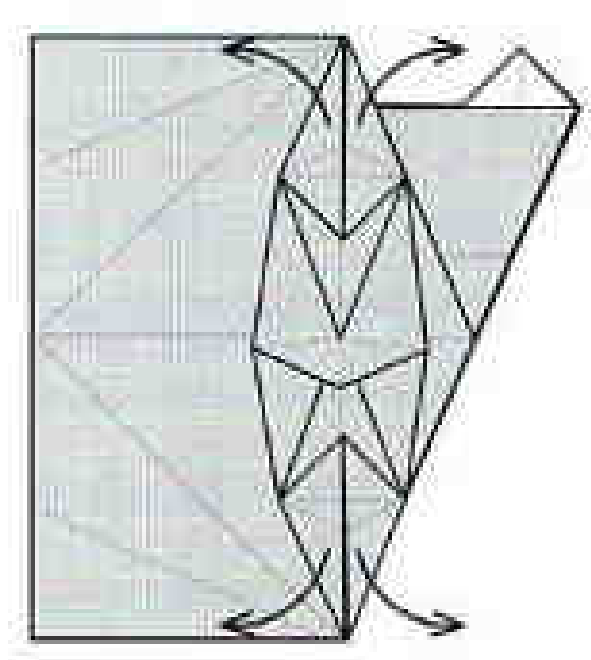

40

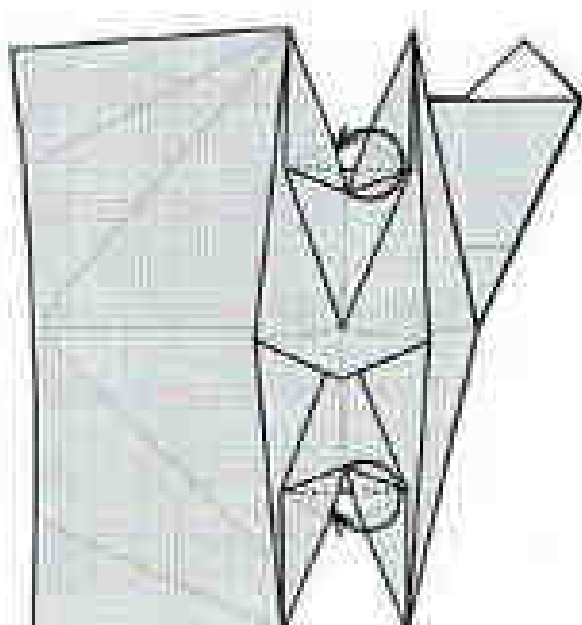

41

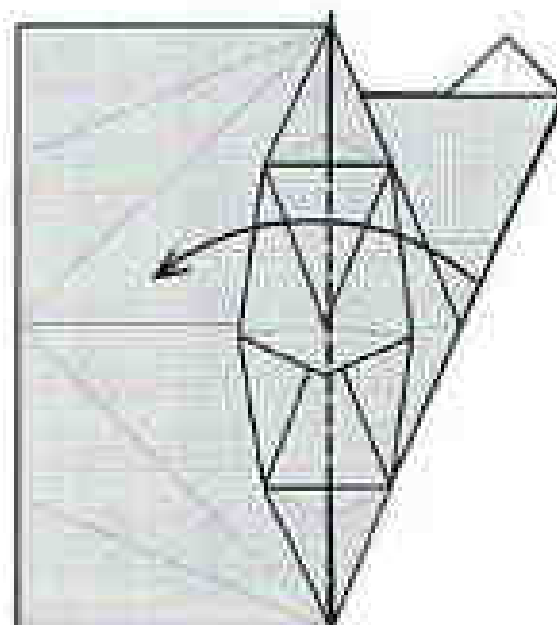

42

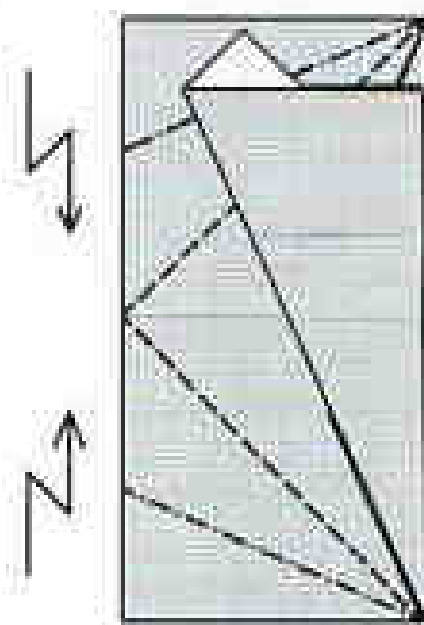

43

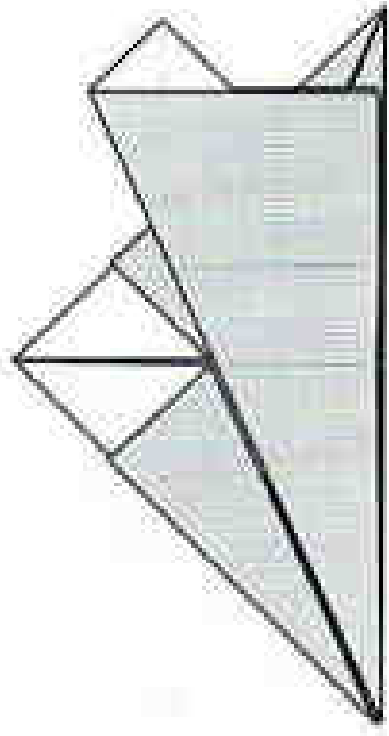

44

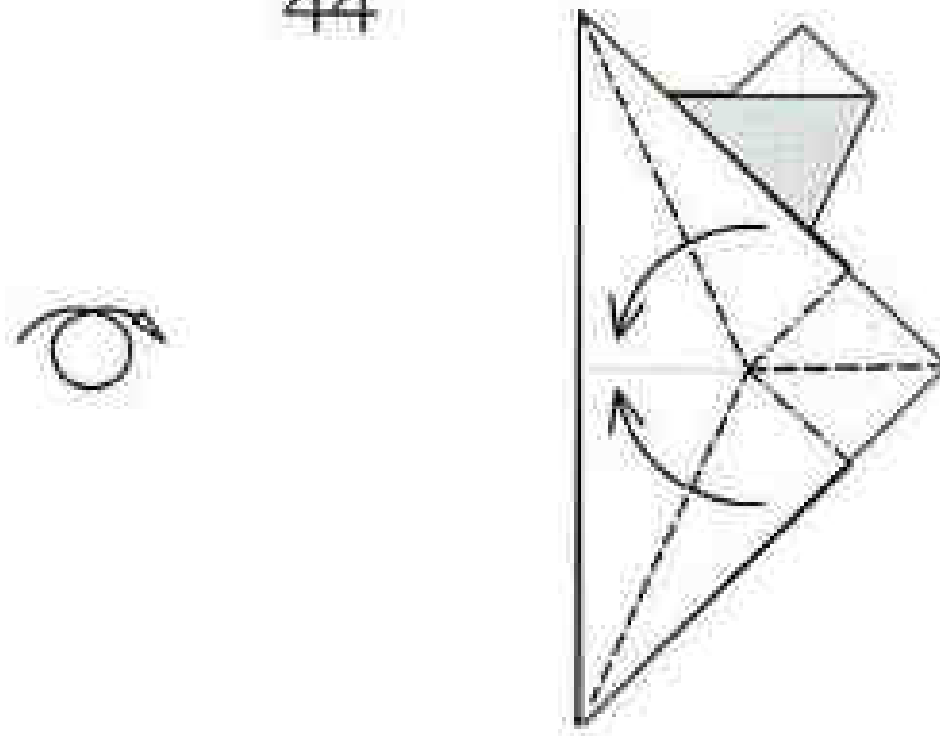

45

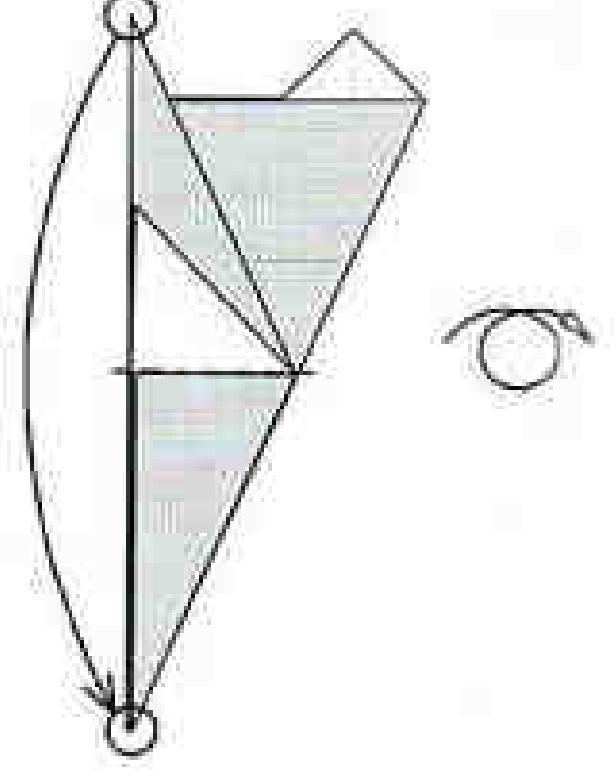

46

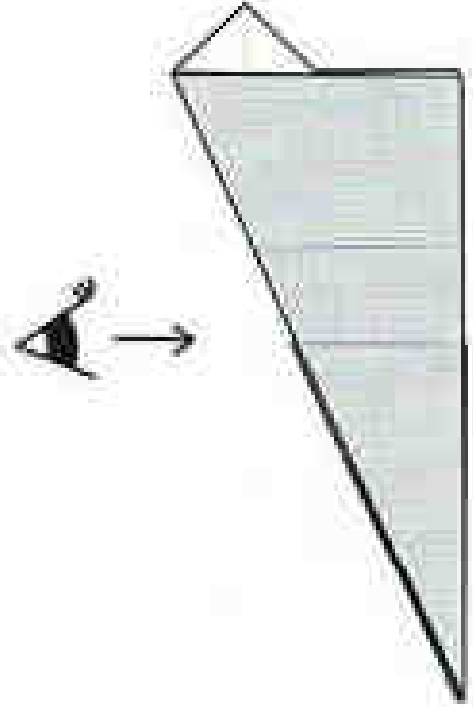

47

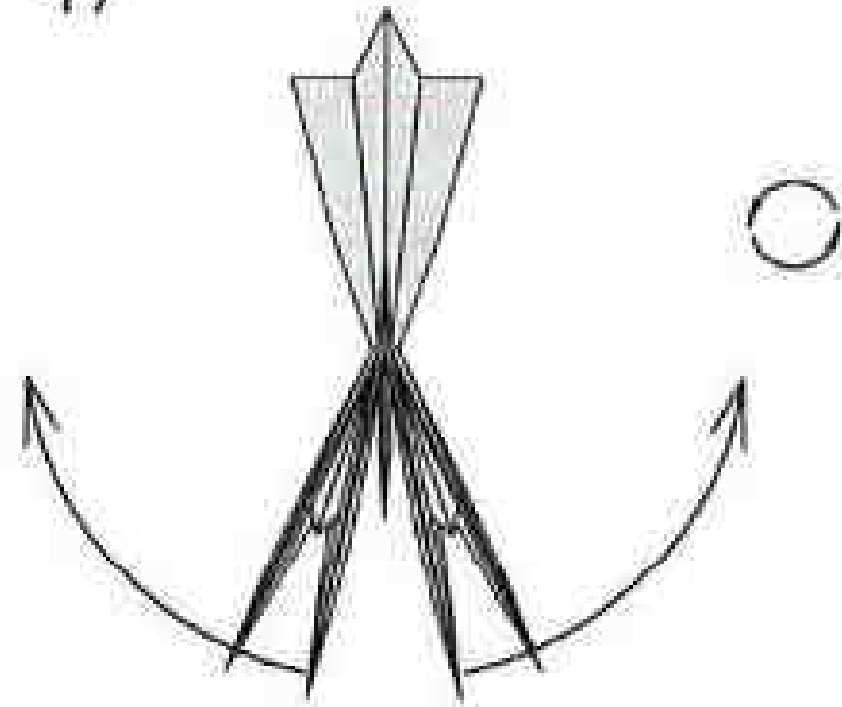

48

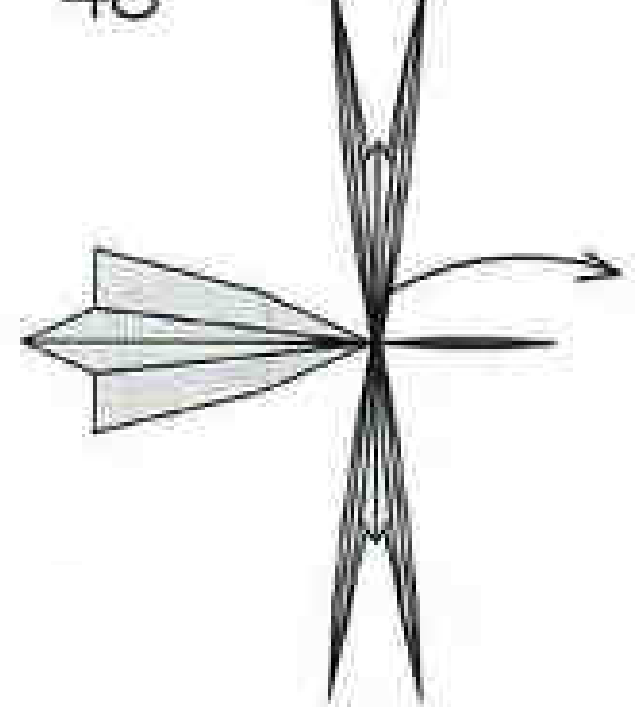

49

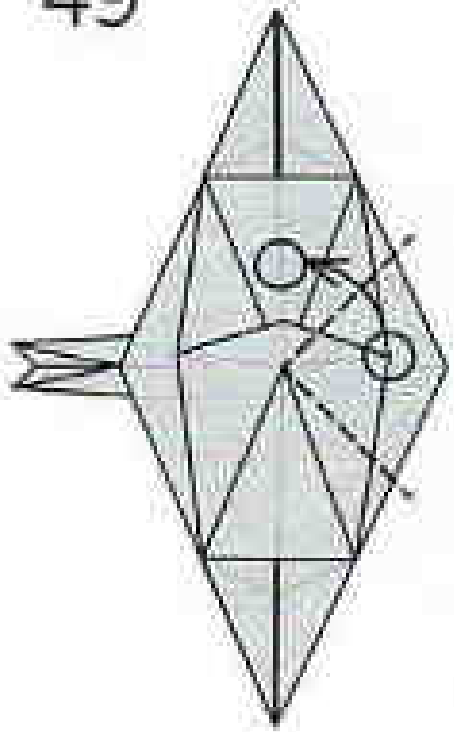

50

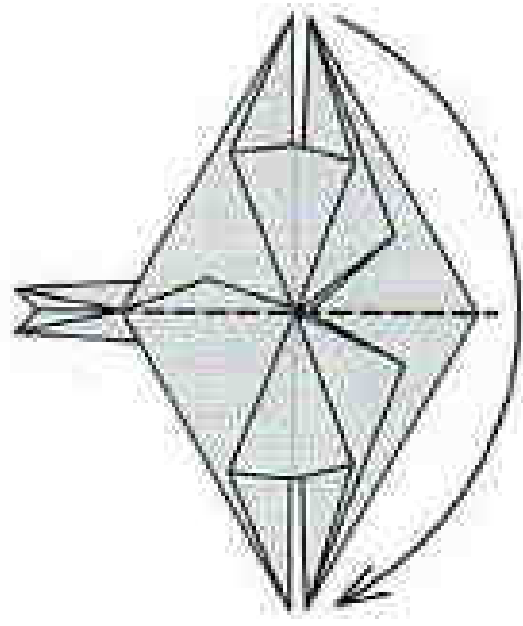

51

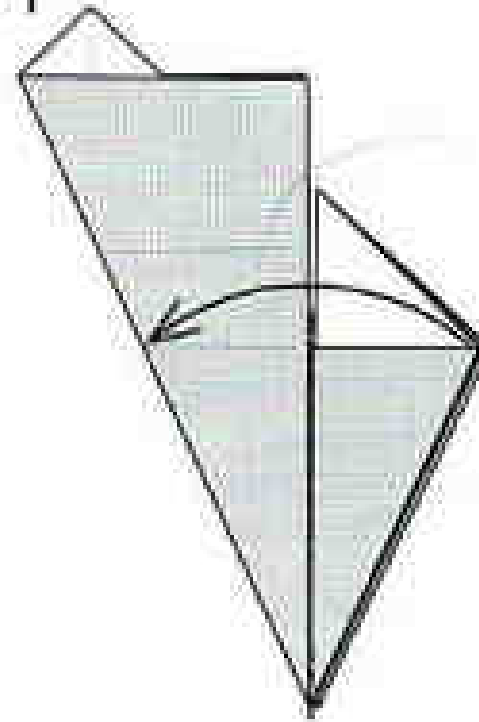

52

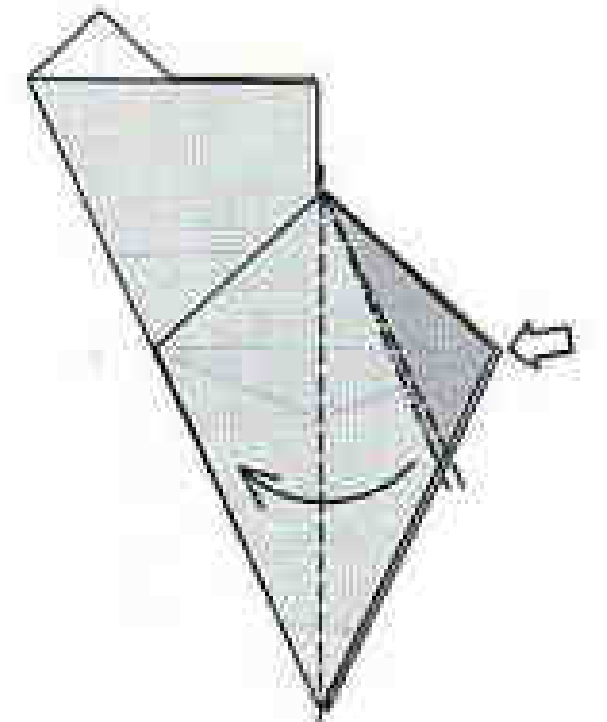

53

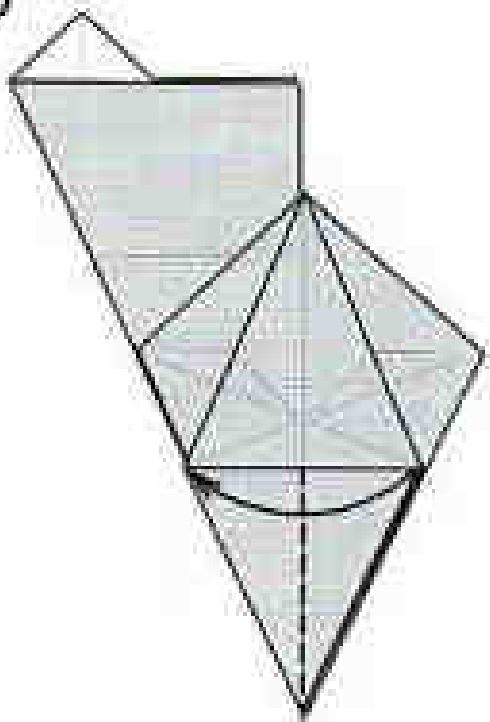

54

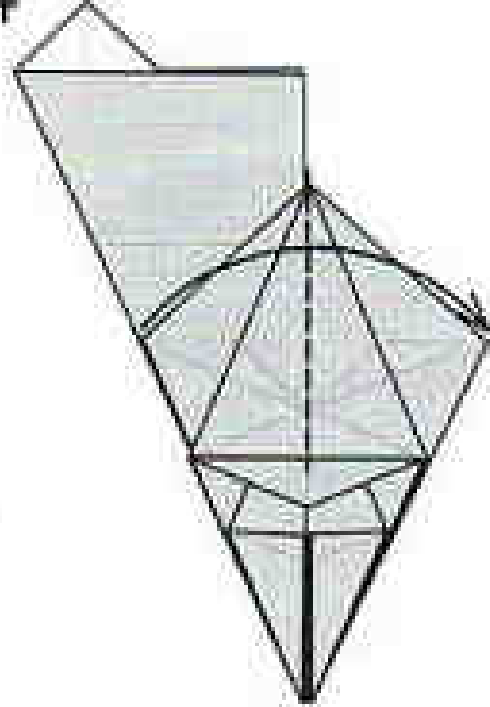

55

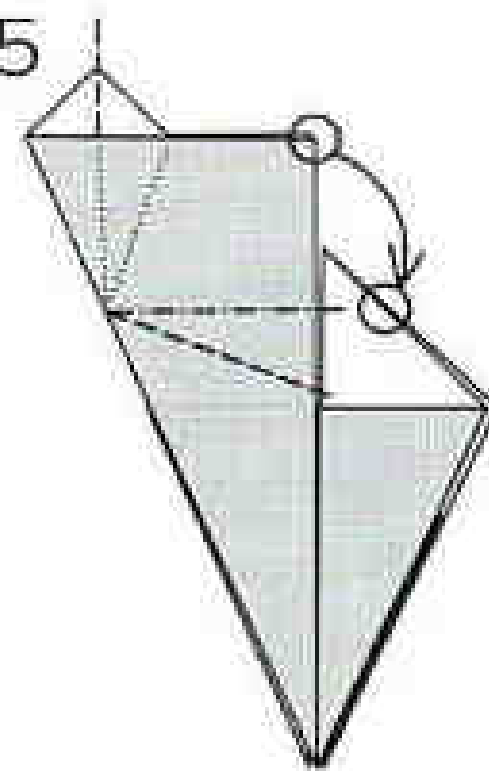

56

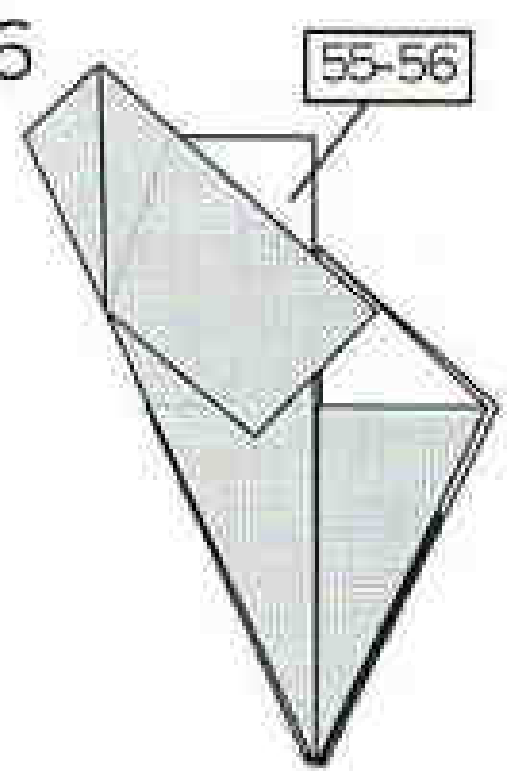

57

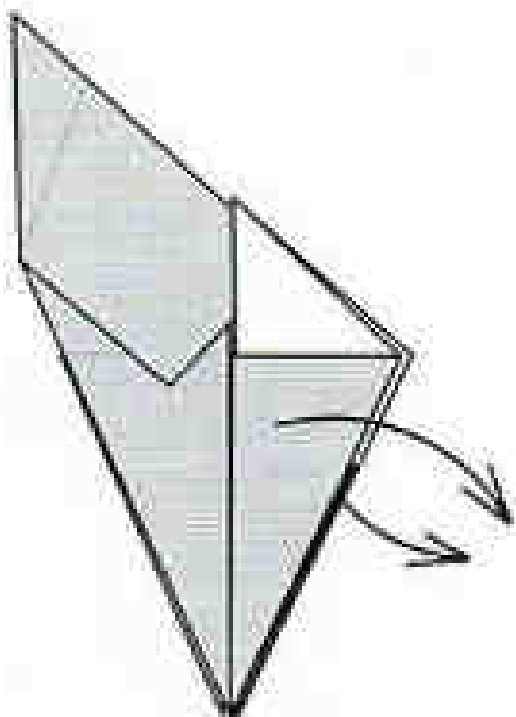

58

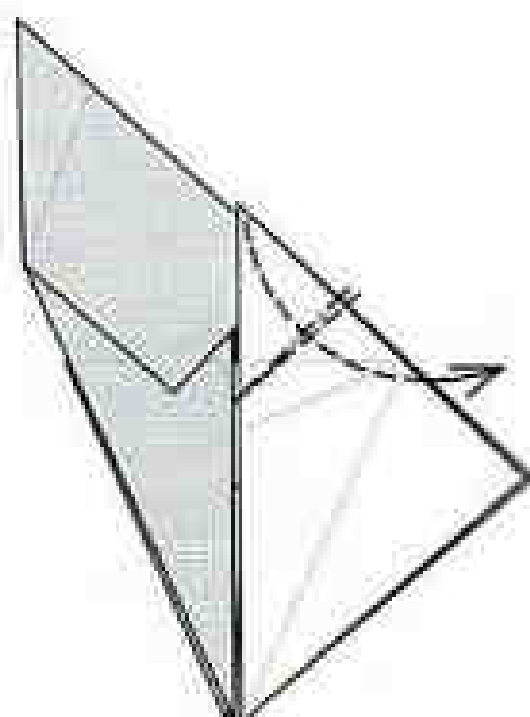

59

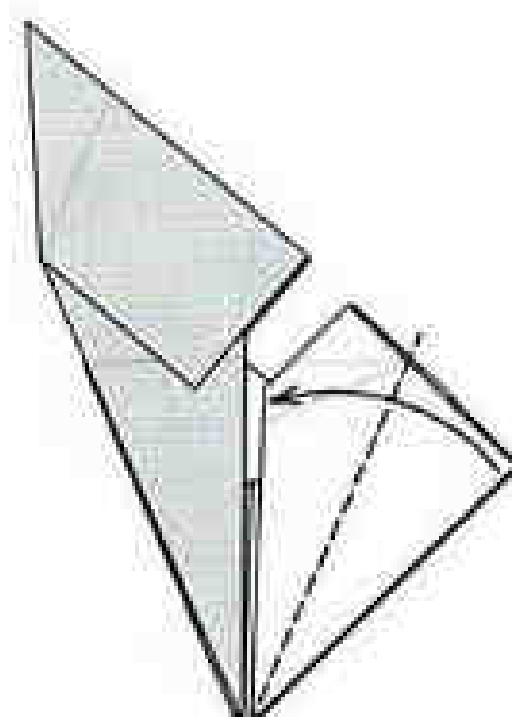

60

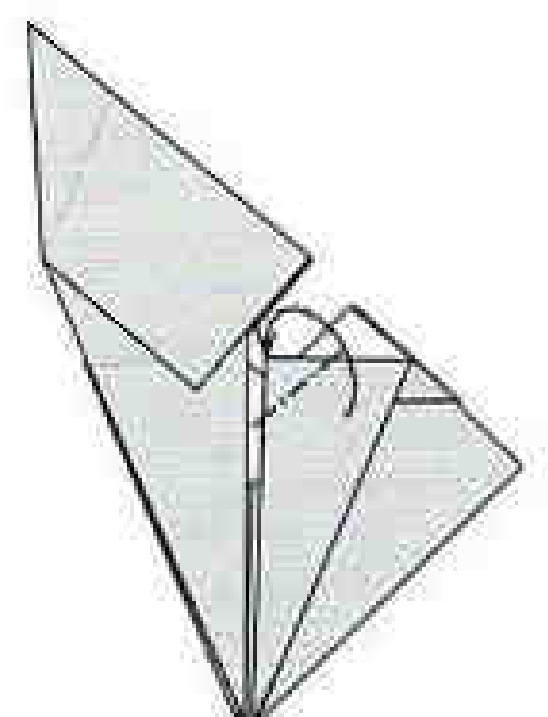

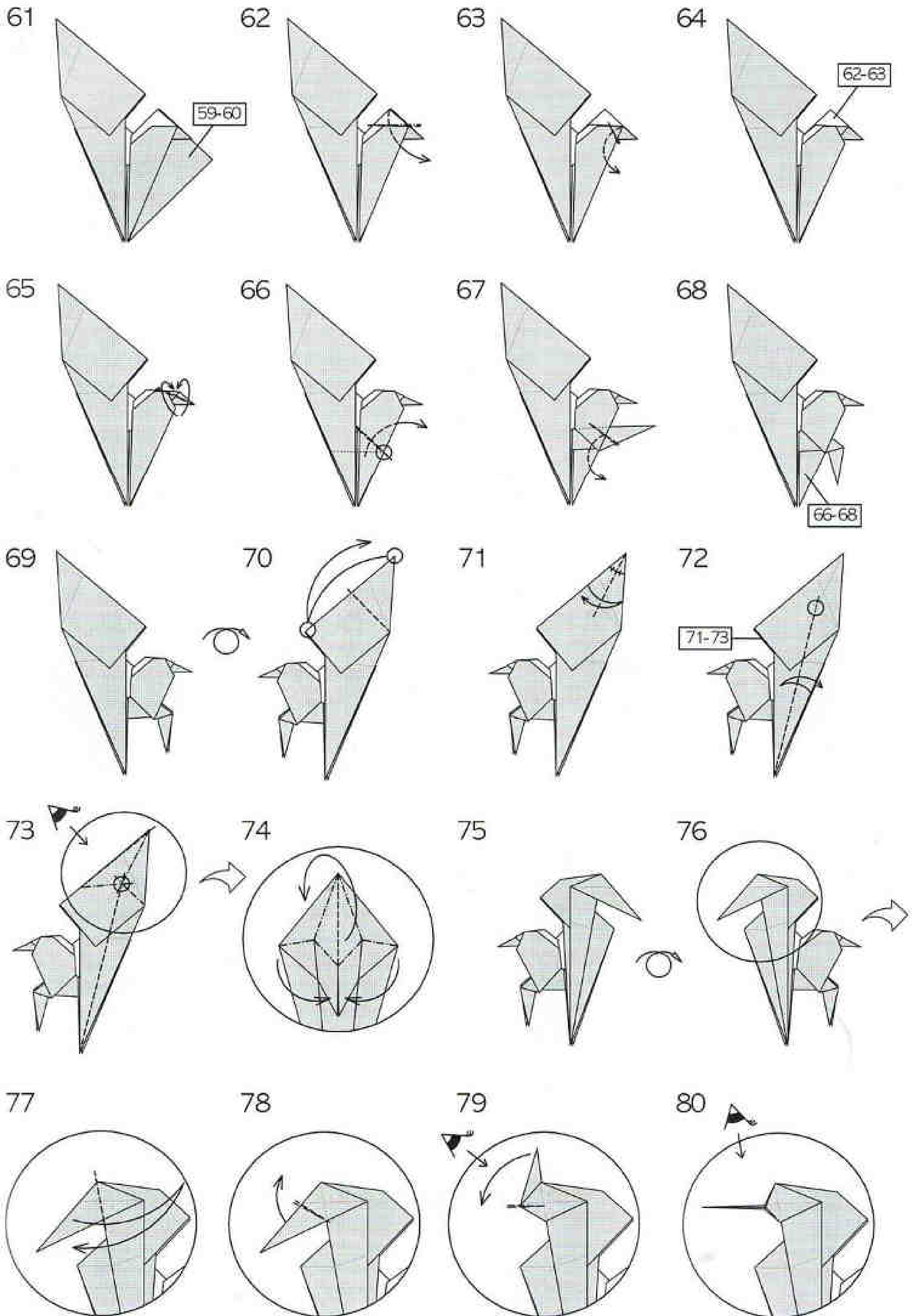

81

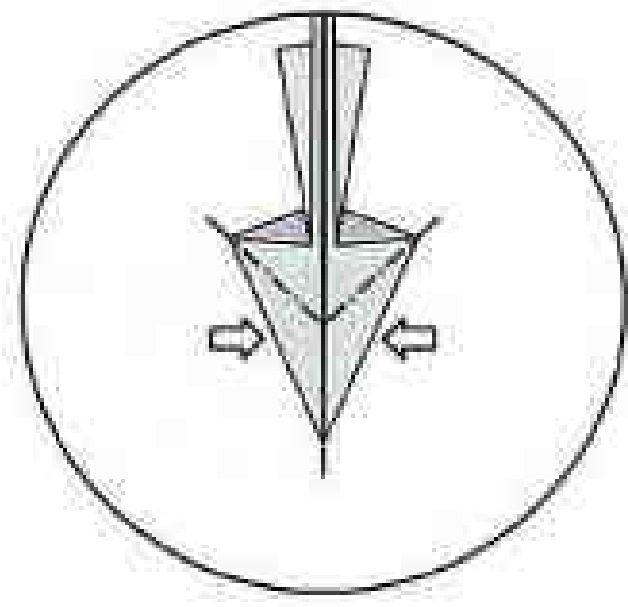

82

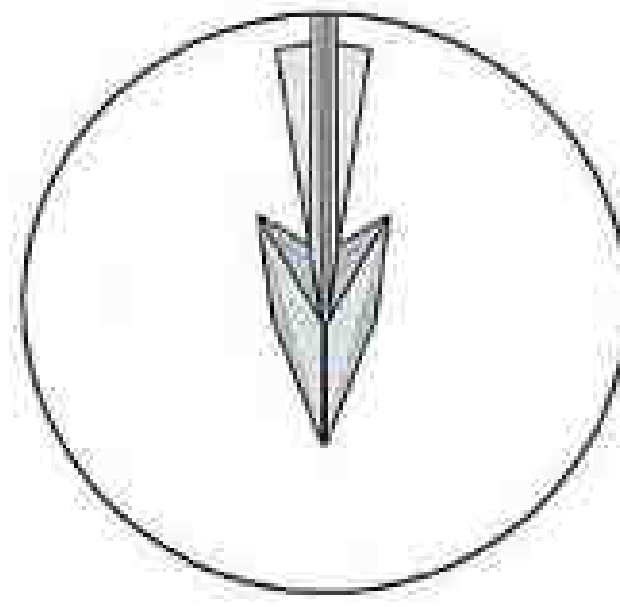

83

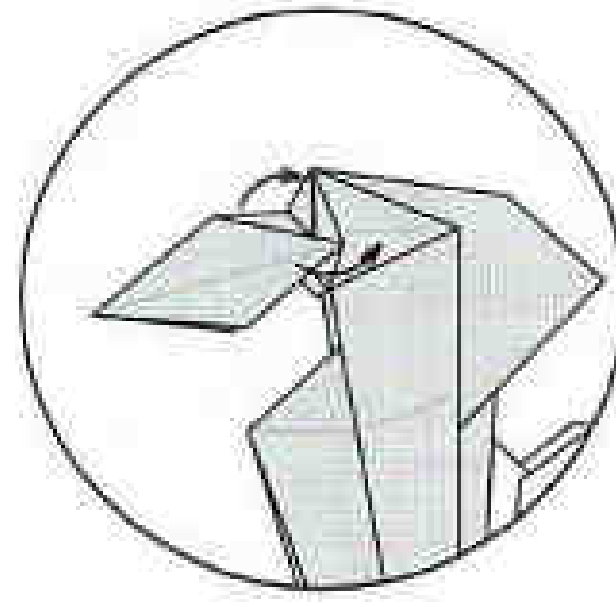

84

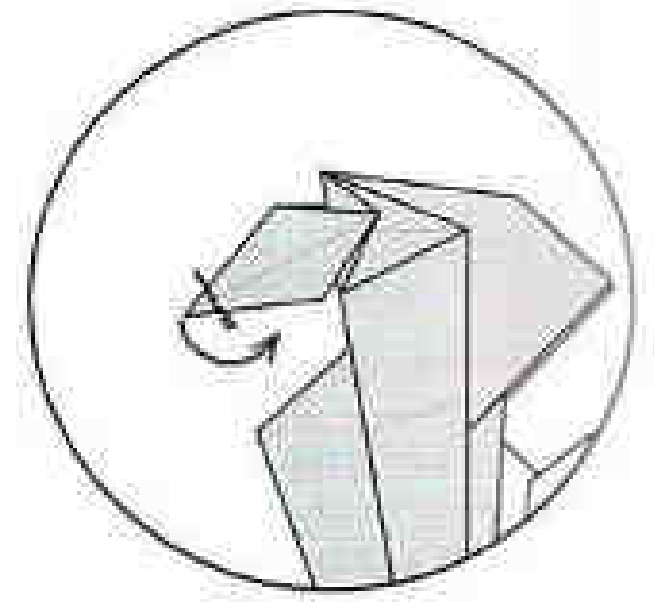

85

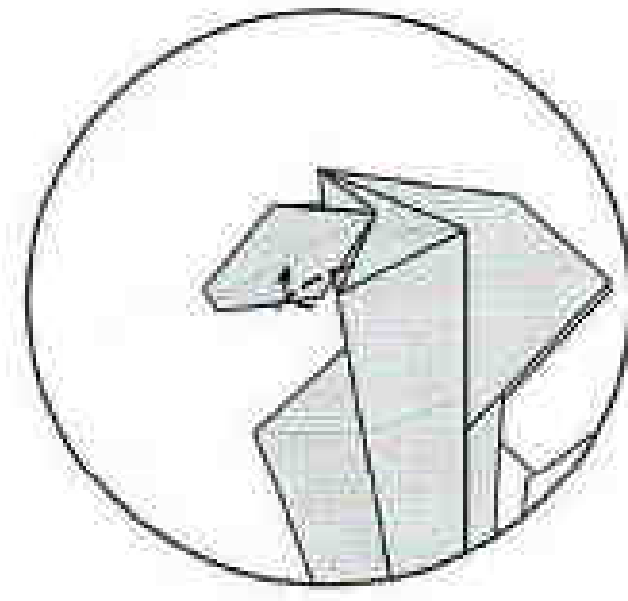

86

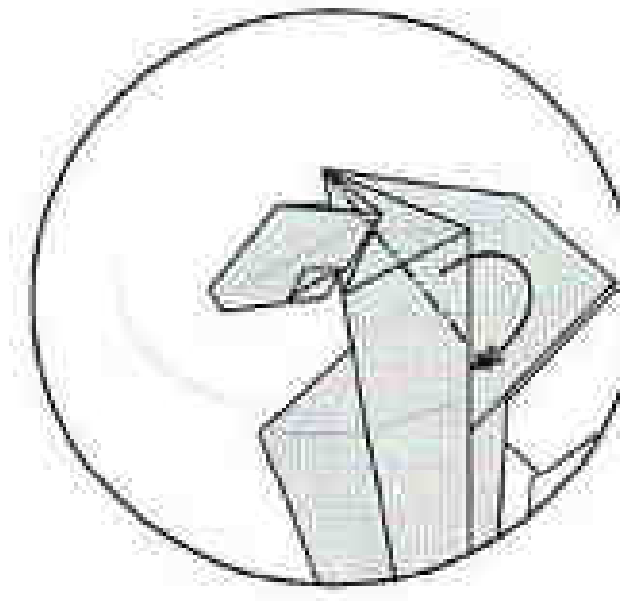

87

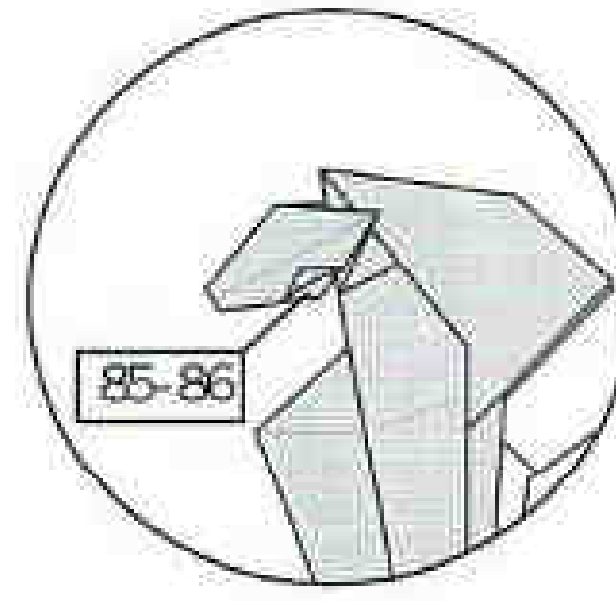

88

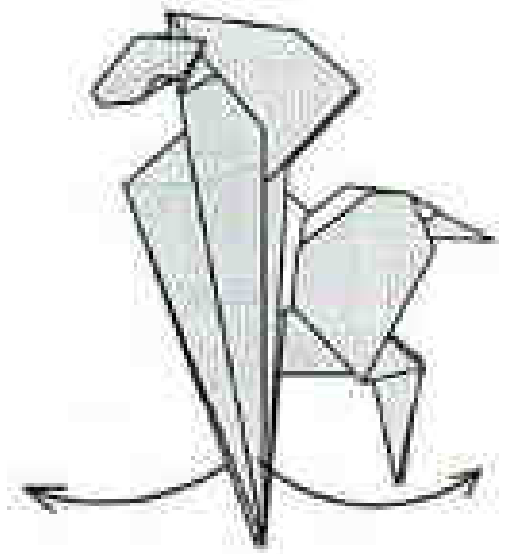

89

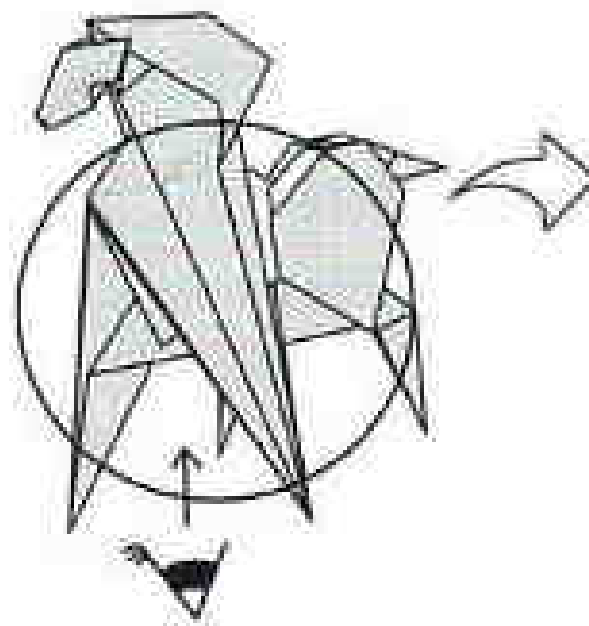

90

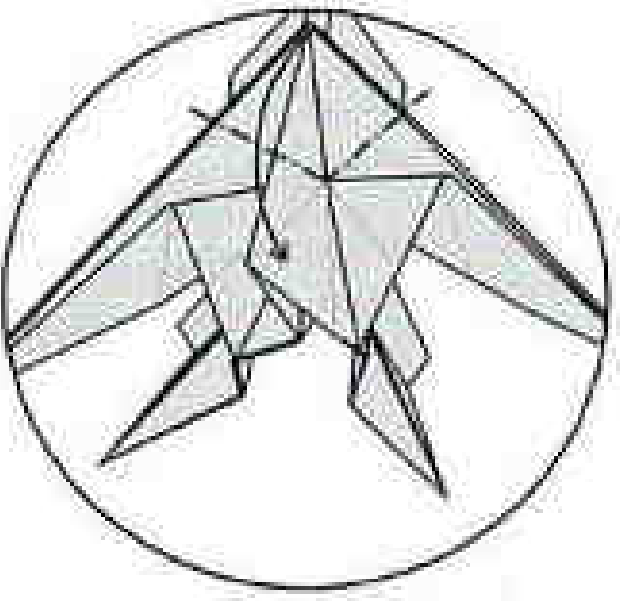

91

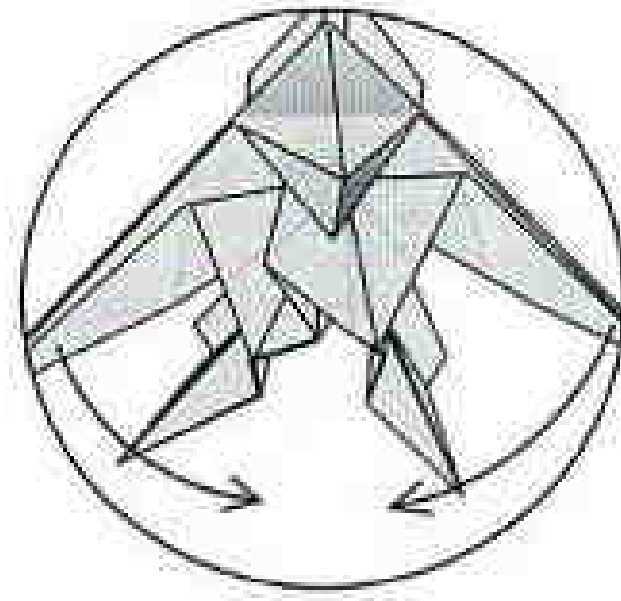

92

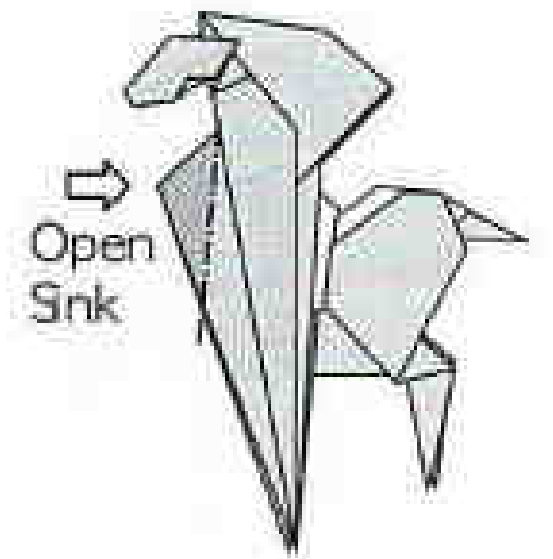

93

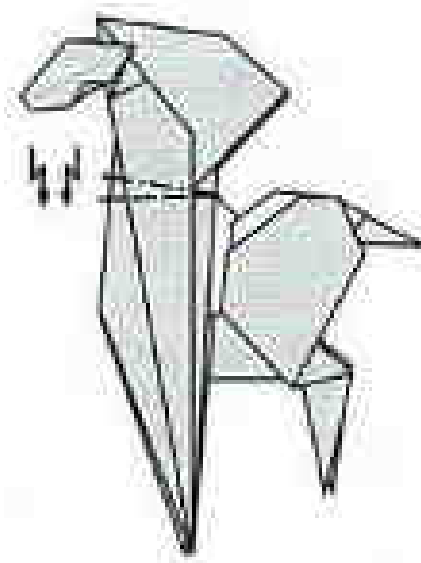

94

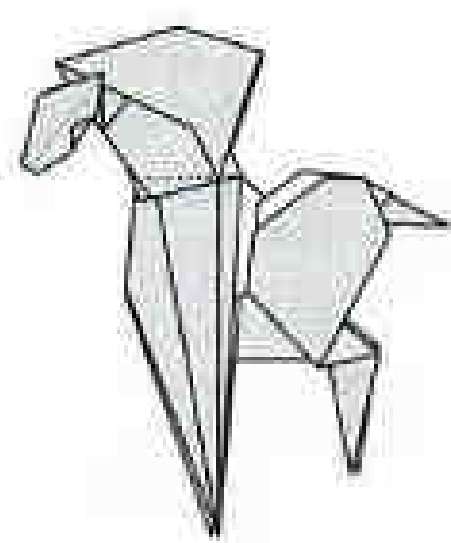

95

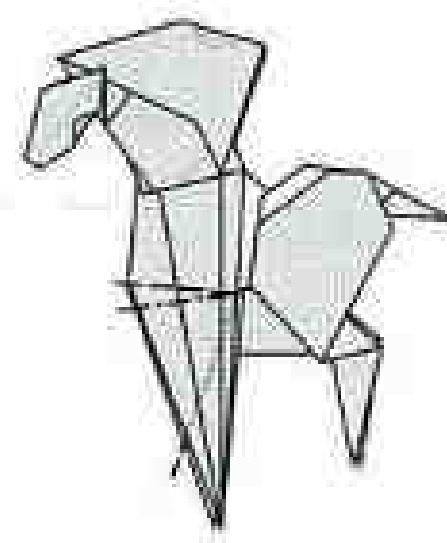

96

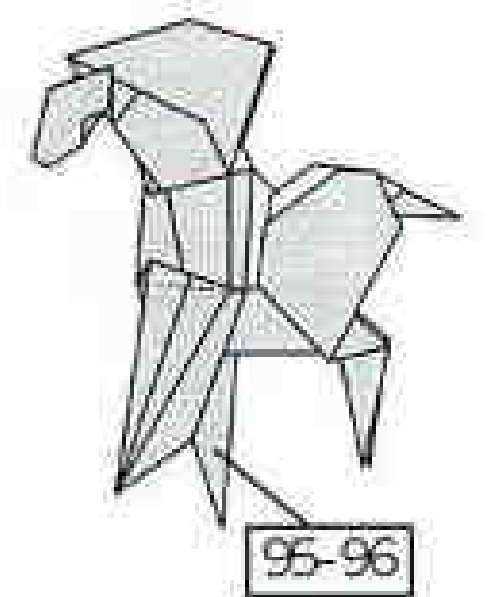

97

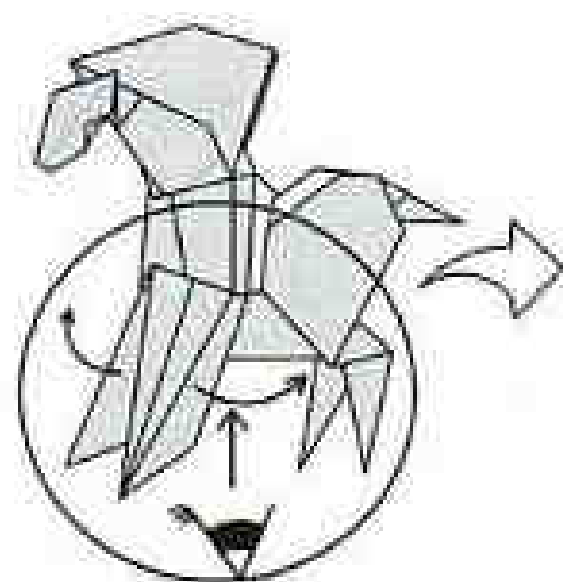

98

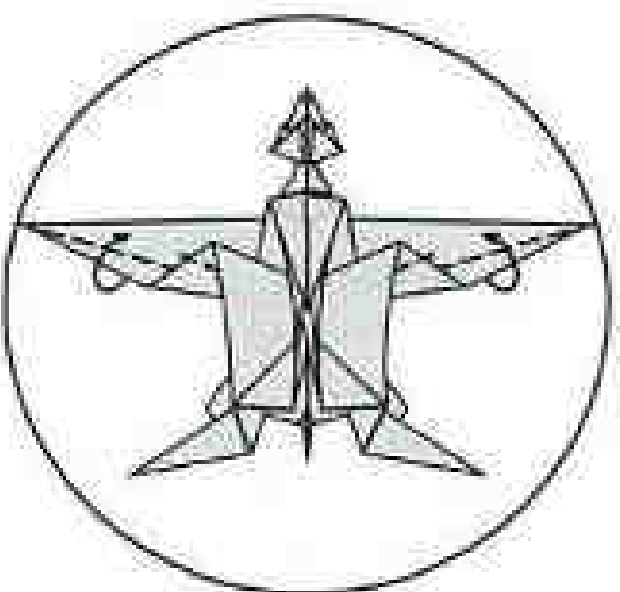

99

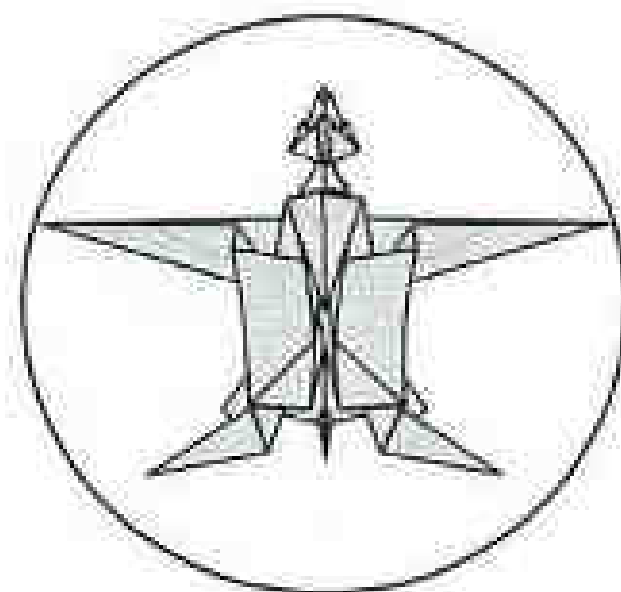

100

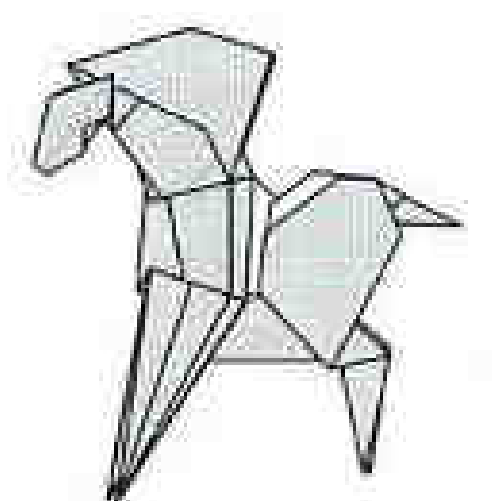

101

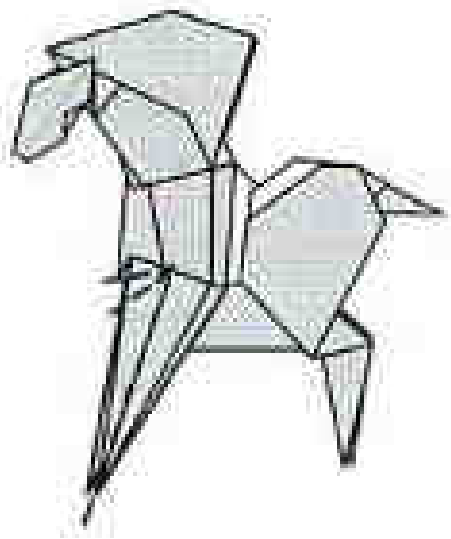

102

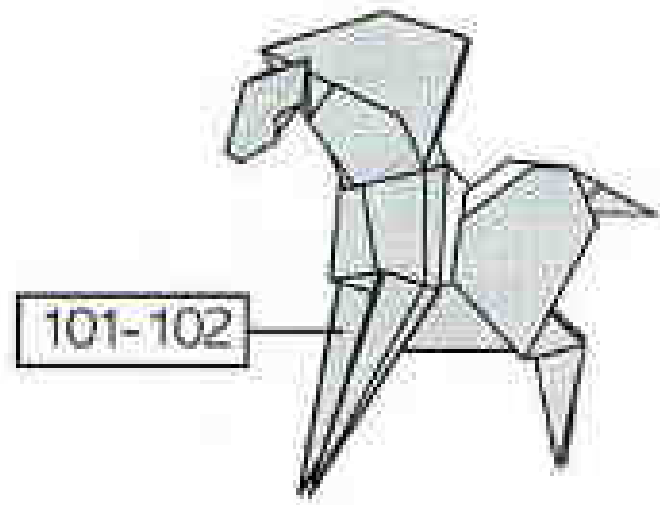

103

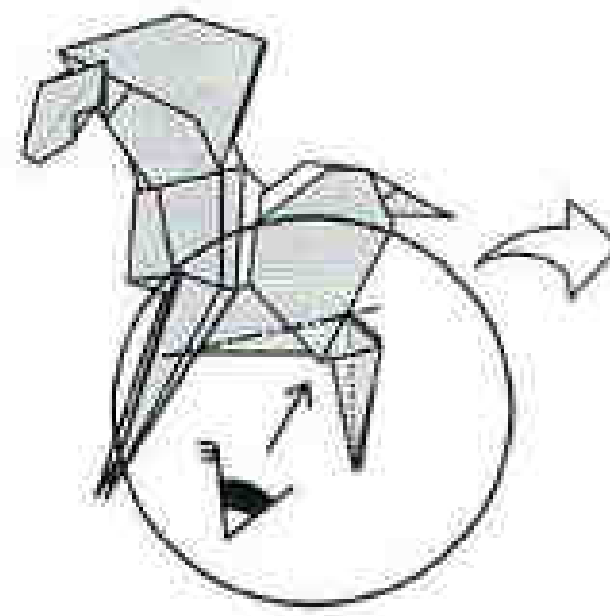

104

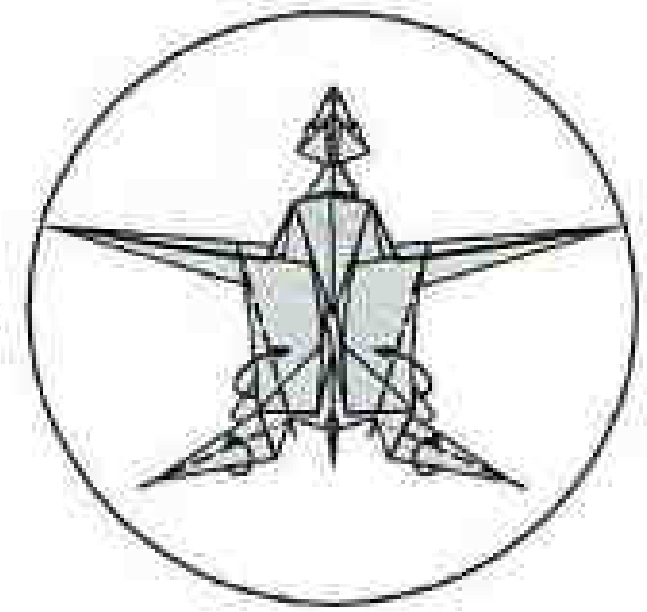

105

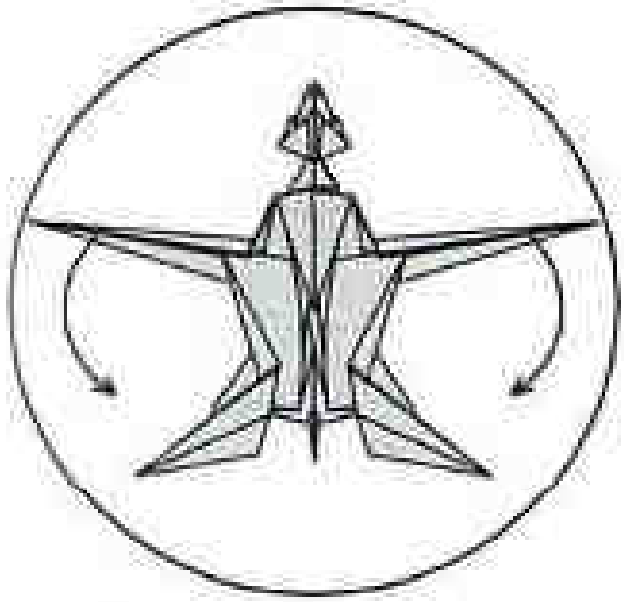

106

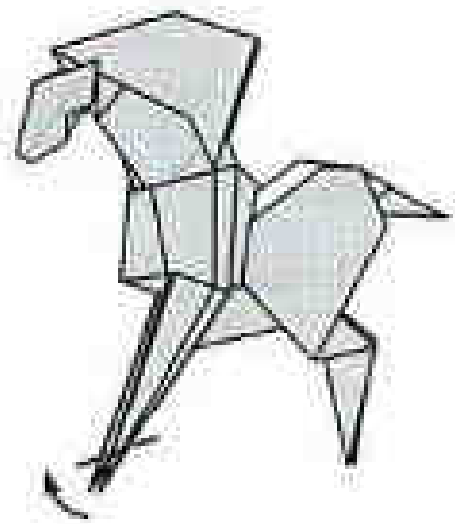

107



108

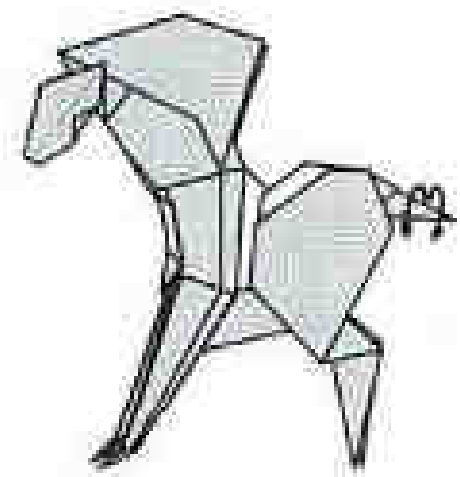

109

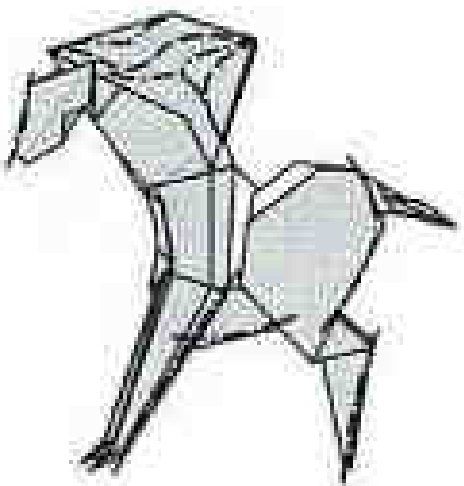

110



완성 Complete

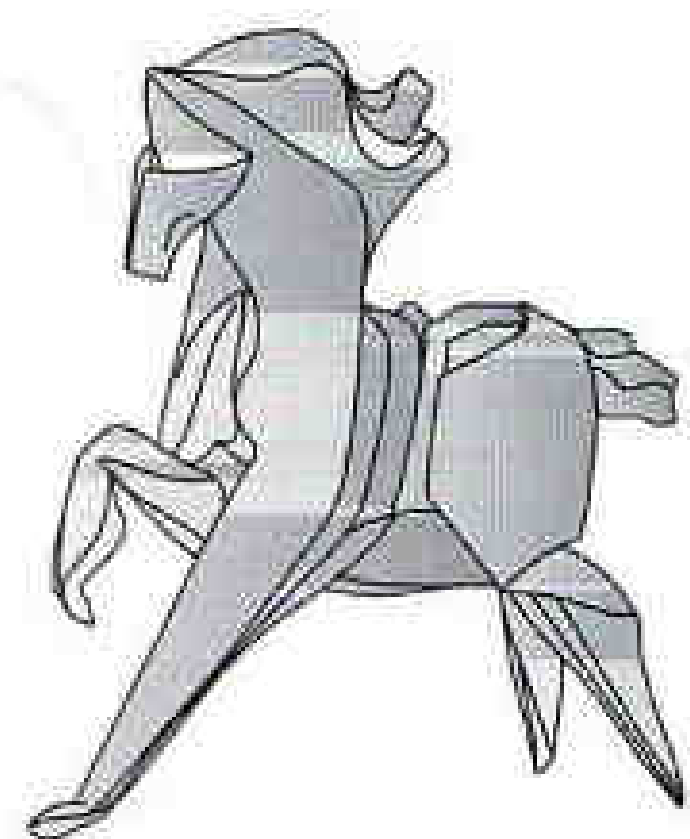
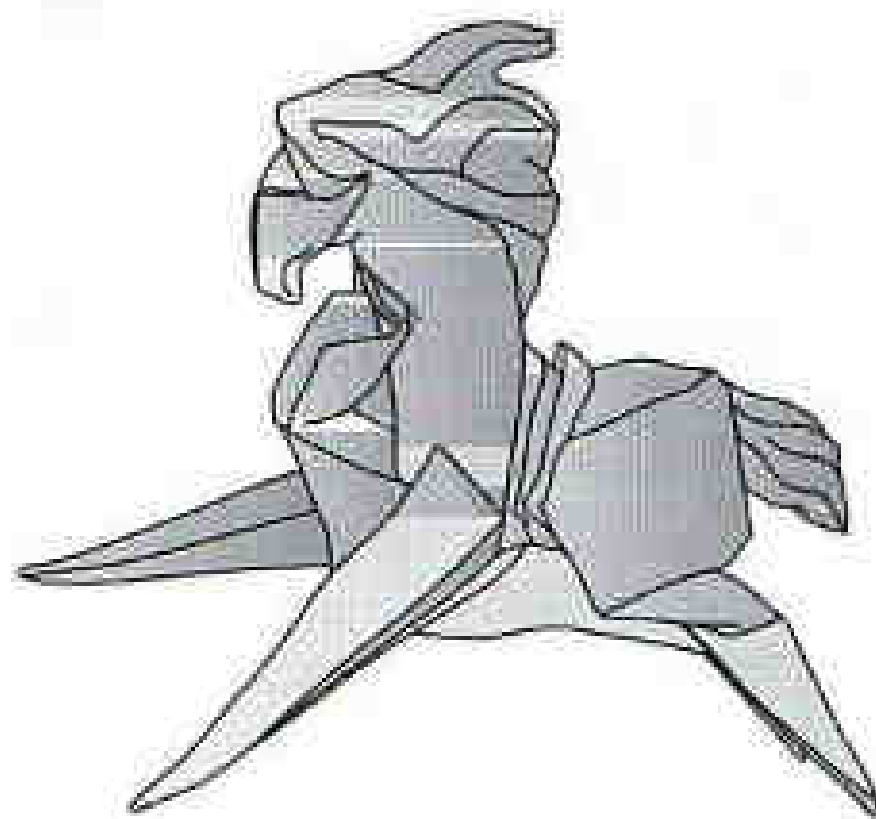
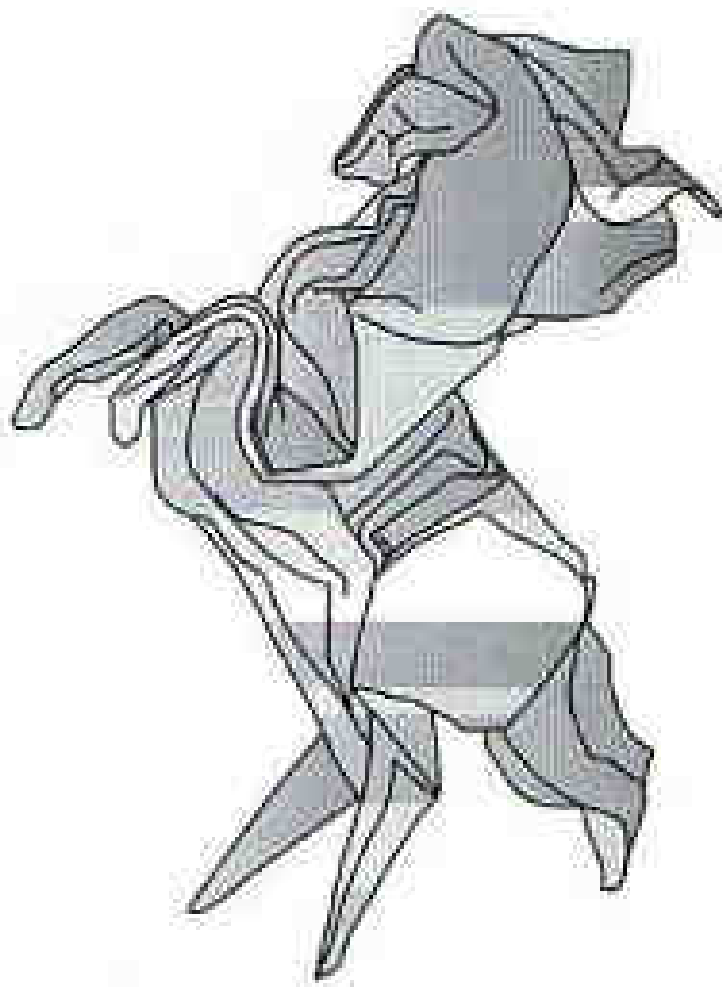

Folded by Nguyen Hung Cuong

주 : 각자가 접은 말의 다리를 다듬어 역동적으로 표현해주세요.

Note : Please take the shape of dynamic legs

전개도 Crease Pattern

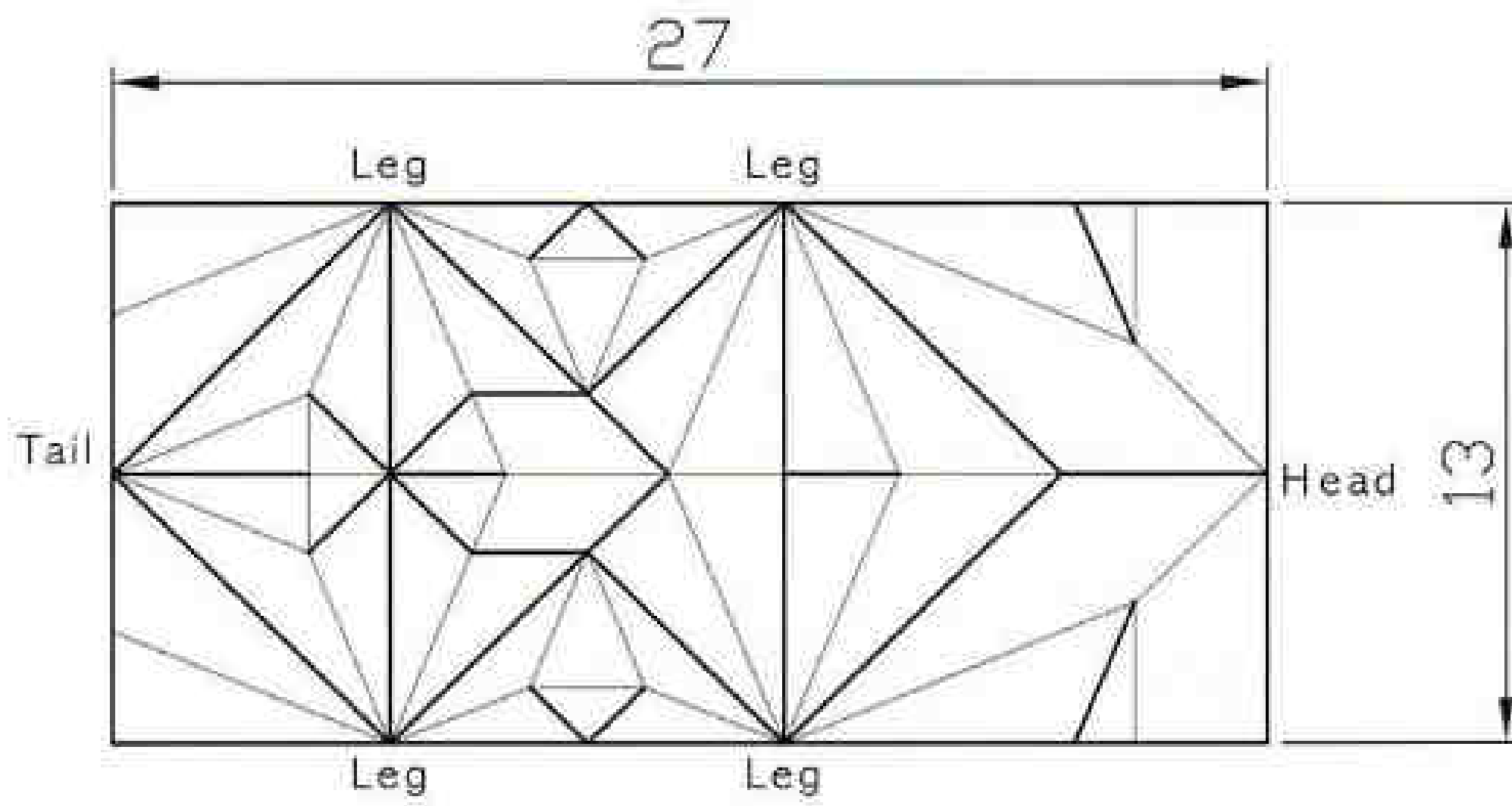

기본형 Base

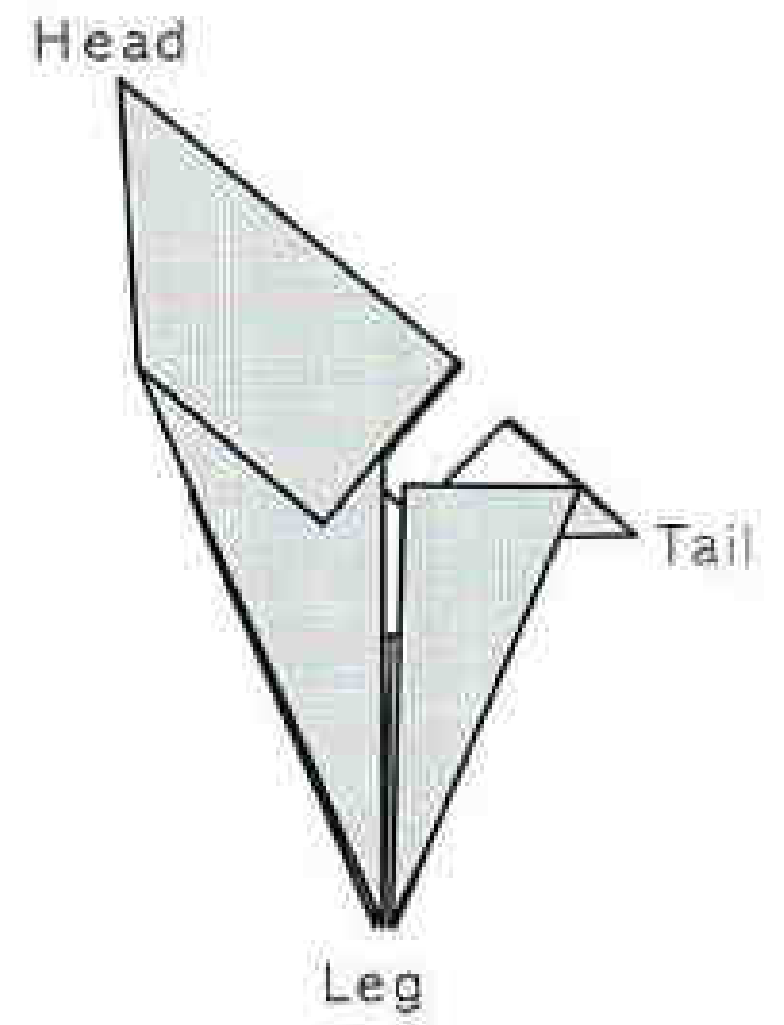

종이 크기 비교 Compare Paper size

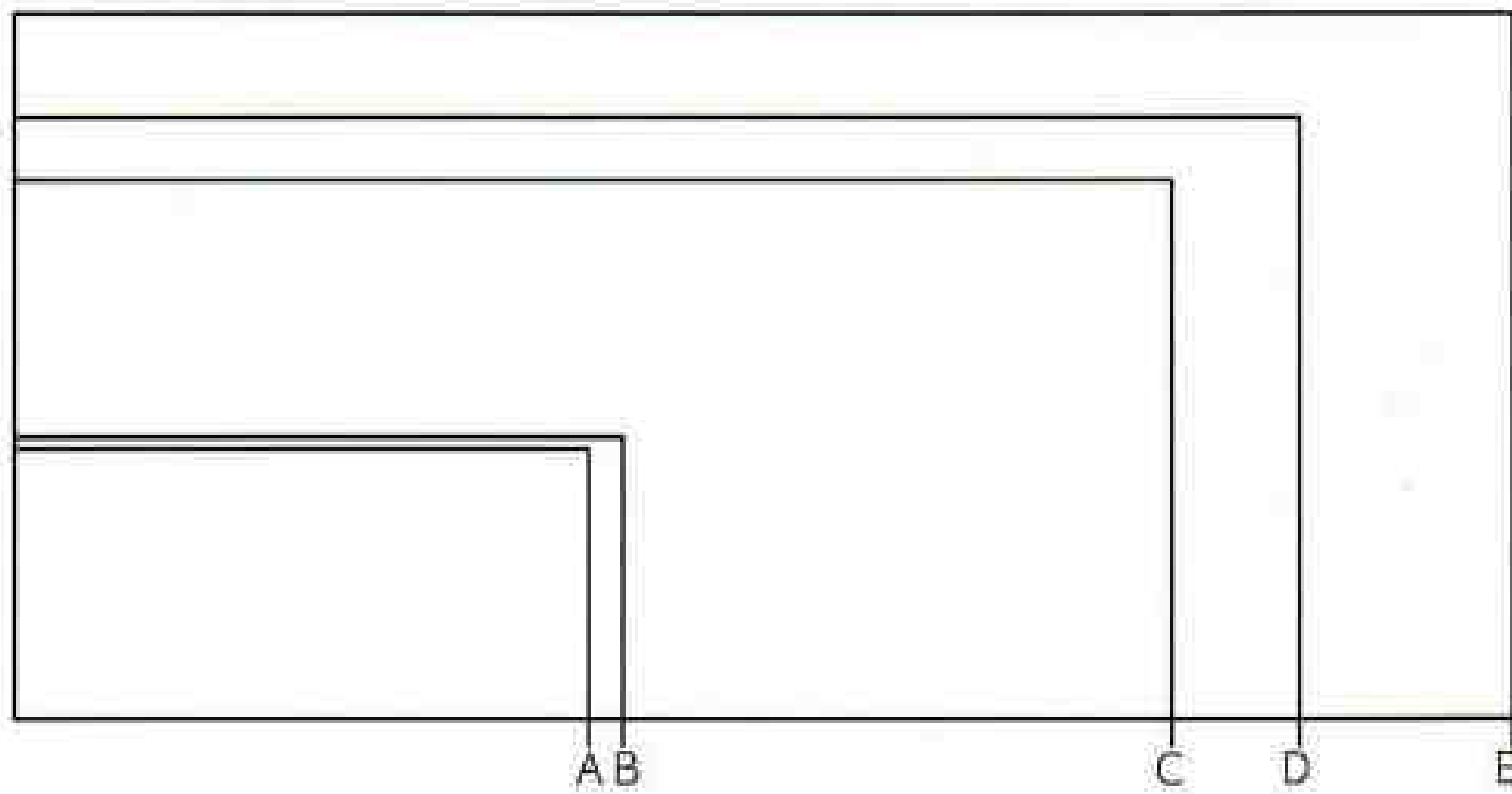

- A : 134 x 65 mm (베트남 2000동 지폐 2000 dong Vietnam Banknote)
- B : 142 x 68 mm (대한민국 5000원 지폐 5000 won Korean Banknote)
- C : 270 x 130 mm (색한지 Duo Color Hanji Paper)
- D : 300 x 145 mm (크라프트지 Craft Paper)
- E : 350 x 170 mm (탄트지 Tant Paper)

완성작 크기 Model Size

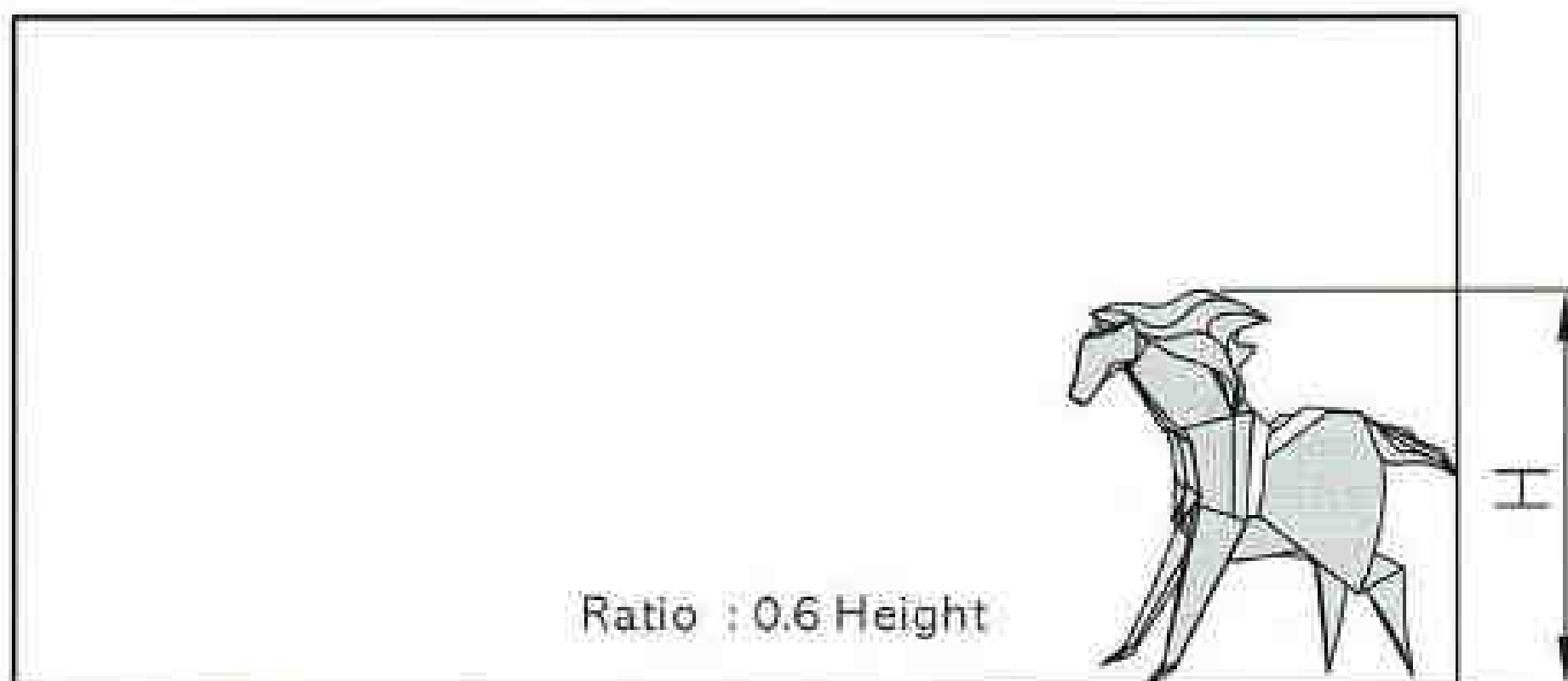

- H = A : 39 mm
- B : 41 mm
- C : 78 mm
- D : 87 mm
- E : 102 mm

종이접기 매니아를 위한

ORIGAMI PRO

동물 종이접기편

초판1쇄 인쇄 | 2015년 8월 20일

초판1쇄 발행 | 2015년 8월 22일

참 여 작 가 | 장용익, 이인섭, 유태웅
Roman Diaz, Ngunyen Hung Cuong

기획 / 편집 | 김진우, 장용익

진 행 | 이송윤, 이경구

감 수 | 김진우

도면 디자인 | 김영민, 김진우, 장용익, 김승균, 유태웅

표지 디자인 | 장용익

발 행 인 | 오경해

펴 낸 곳 | (사) 한국종이접기협회

주 소 | 서울시 중구 다산로64 (신당동 366-104)

전 화 | 02 - 2264 - 4561

팩 스 | 02 - 2264 - 4565

홈 페이지 | www.origami.or.kr

등록 번호 | 제6-0112호

- 이 책은 저작권법에 따라 보호받는 저작물이므로 무단전제와 복제를 금합니다.

- 이 책 내용의 전부 또는 일부를 이용하려면 반드시 저작권자와 (사)한국종이접기협회의 서면 동의를 받아야 합니다.

- (사) 한국종이접기협회에서 출간되는 [ORIGAMI PRO - 동물 종이접기편]의 판매 수익금은 창작 종이접기 작가 육성을 위해 사용됩니다.

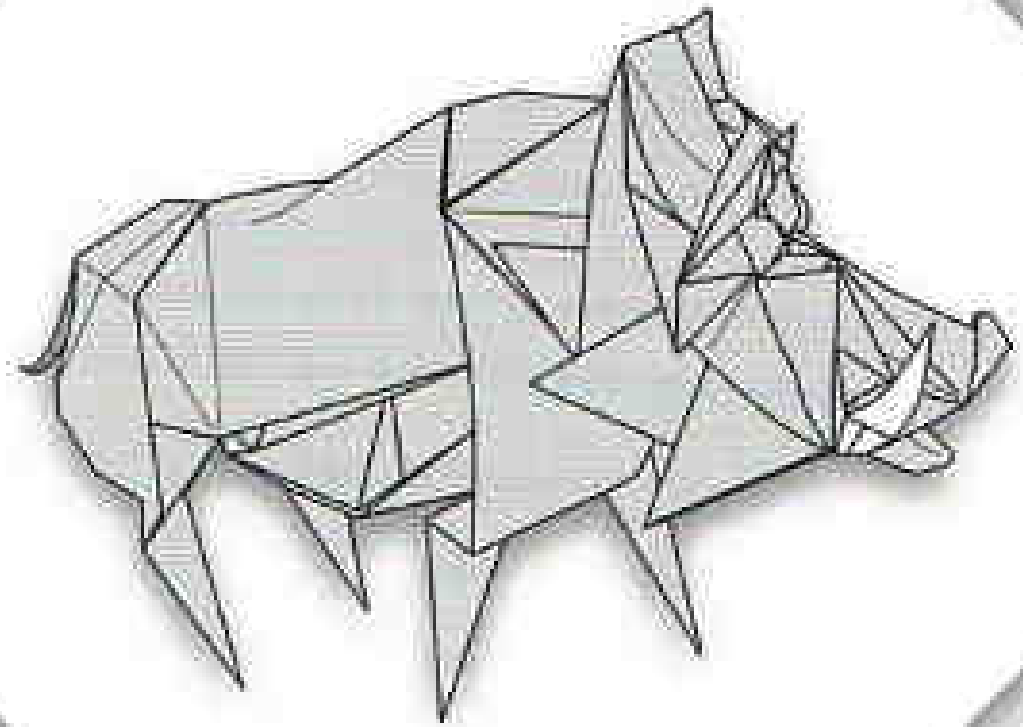
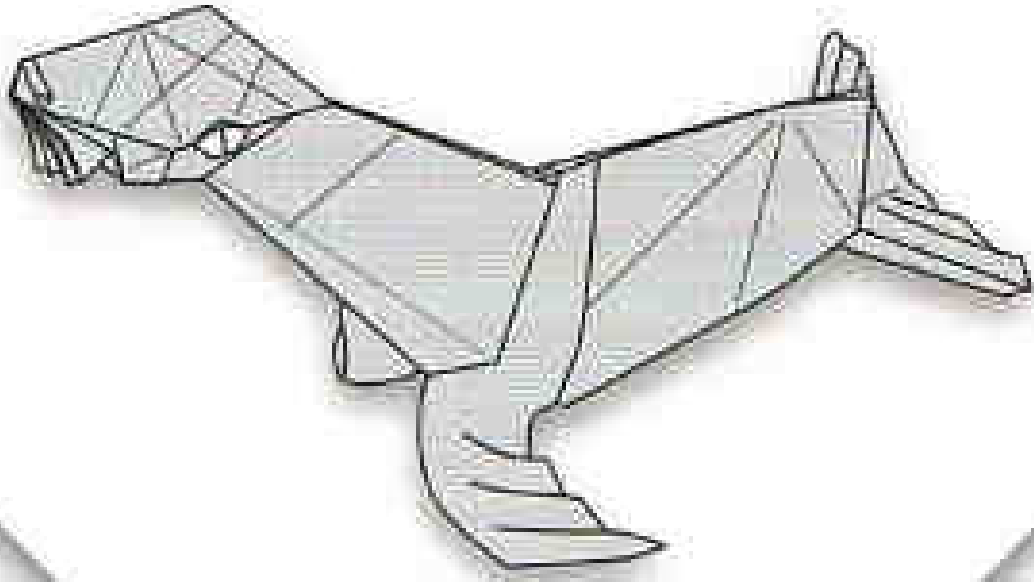
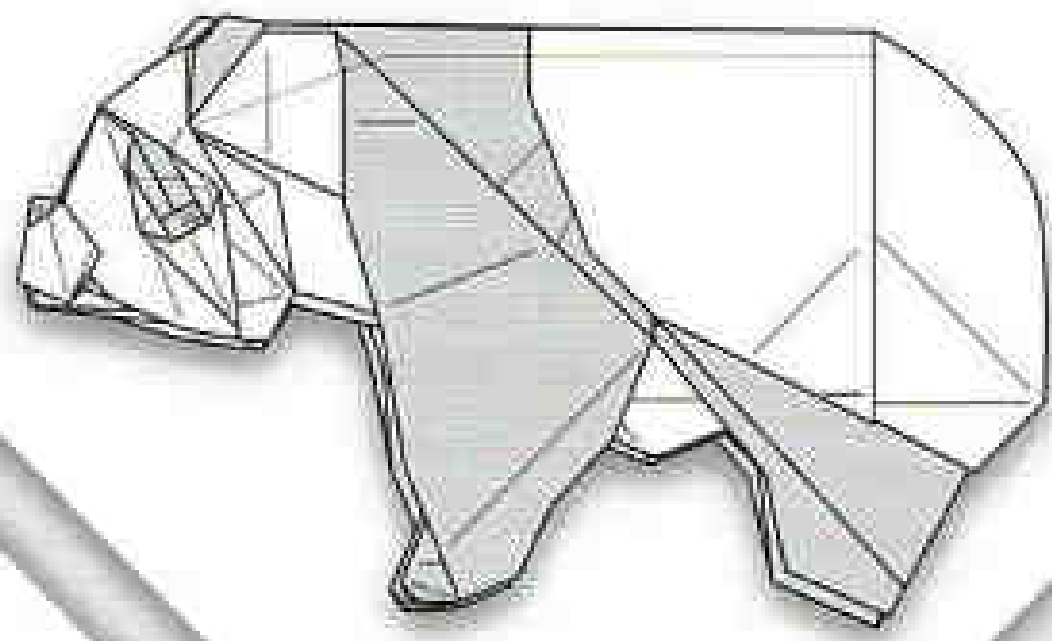

ORIGAMI
P R O
동물 종이접기편

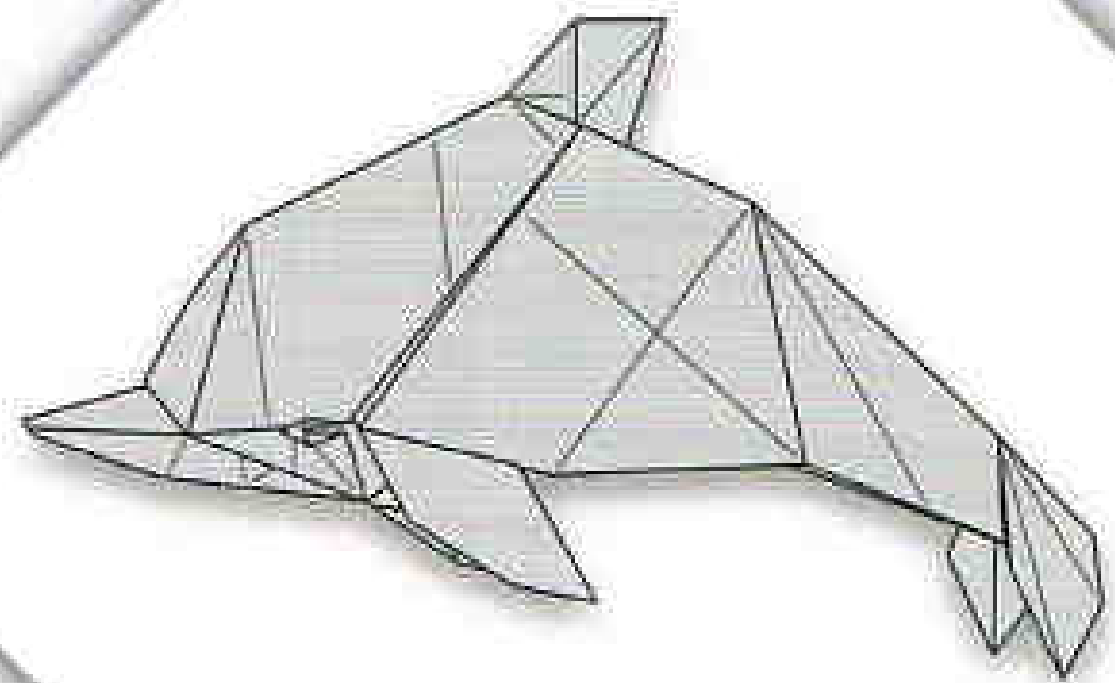

값 11,000원



ISBN 978-89-97772-14-8



대한민국
한국종이접기협회
KOREA ORIGAMI ASSOCIATION