

Popularised by the media, this spectacular animal is feared the world over. Unfortunately it is also a popular target for sport fishing which has caused its numbers to drop rapidly!

It is mainly distinguished by its size, white underside, triangular dorsal fin and crescent-shaped tail fin. It also has a sharp, conical snout, sickle-shaped pectoral fins and large triangular serrated teeth.

My main focus when designing this model was to have all the fins in relative proportion and the colour-changed underside. Some stretching techniques were used to produce the closed back. The tail fin also presented a challenge due to the fairly symmetrical shape as opposed to for example the tail fin of a Tiger Shark.

Use as thin paper as possible to reduce the thickness of the layers where the colour-changes meet.

Popularisé par les médias, cet animal spectaculaire est craint dans le monde entier.

Malheureusement, il est aussi très populaire lors de pêche sportive ce qui fait baisser rapidement sa population.

Ce requin se distingue principalement par sa taille, son ventre blanc, sa nageoire dorsale de forme triangulaire et sa nageoire caudale en forme de croissant. Il a également un museau en forme de cône, de grandes nageoires pectorales en forme de faucille et des dents triangulaires pointues.

Lors de sa conception, j'ai mis l'accent sur la bonne proportion des nageoires et le changement de couleur du ventre. Le dos fermé est obtenu par une technique d'étirement.

La nageoire caudale a présenté aussi un défi en raison de la forme assez symétrique à la différence de la nageoire caudale d'un requin-tigre.

Utilisez du papier aussi fin que possible pour réduire l'épaisseur des couches là où se trouve le changement de couleur.

# Great White Shark

## Grand requin blanc

**Design and diagram info:**

**Design et diagramme :**

Date : 6 March 2009 / 6 mars 2009

Difficulty: Complex

Difficulté : Complexe

Time to fold / Temps de pliage : 2 h

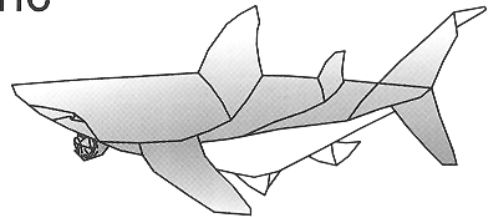

**Crease Pattern :**

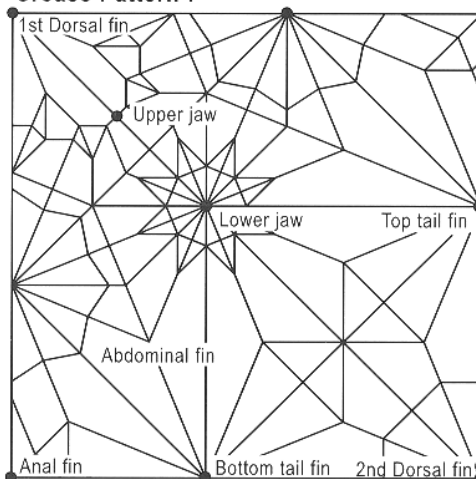

**Paper / Papier :**

Single Uncut square  
Size / Taille : 50 cm  
Color / Couleur : Gray  
- White / Gris - Blanc

Type : Kami  OK  
Foil / Métallisé  Best  
Wet-fold  Best

Ratio: 0.47 Length / Longueur

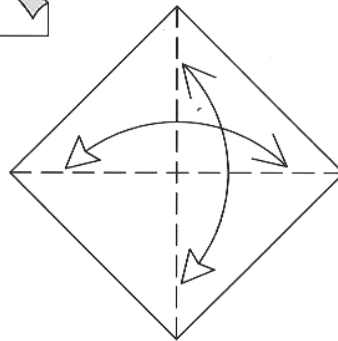
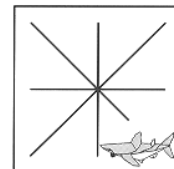

1. Pre-crease.

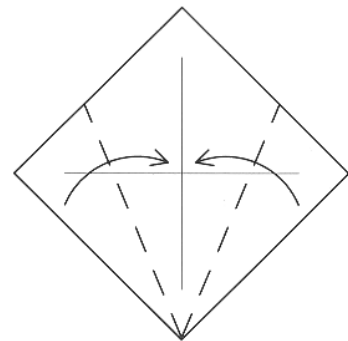

2. Valley-folds along angle bisectors.

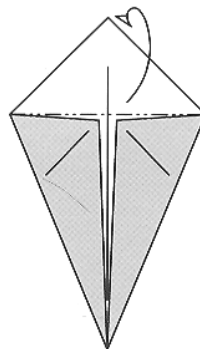

3. Mountain-fold.

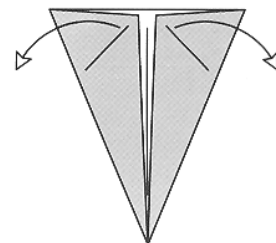

4. Unfold.



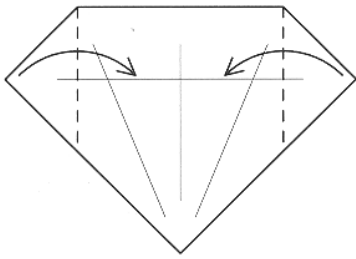

5. Valley-folds.

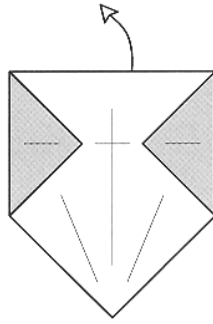

6. Unfold the raw corner.

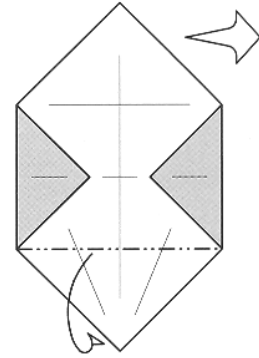

7. Mountain-fold. Detailed view.

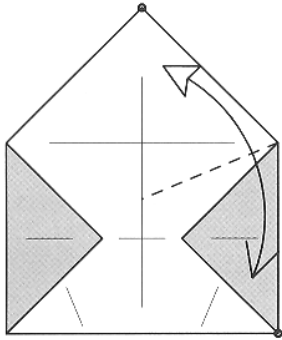

8. Valley-fold marker to marker and unfold.

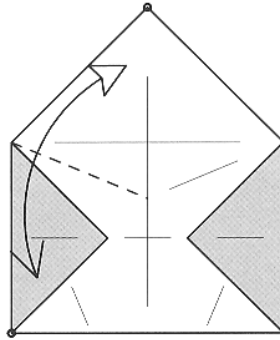

9. Repeat step 8 on the left.

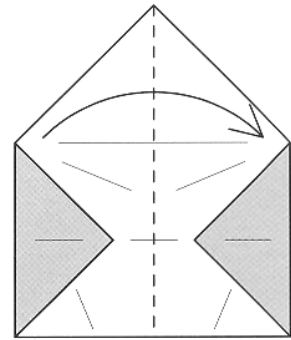

10. Valley-fold in half.

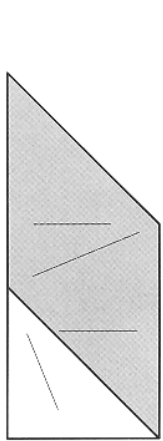

11. Rotate.

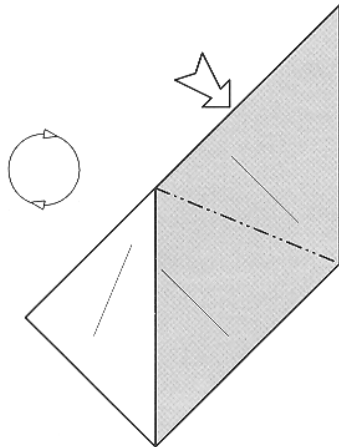

12. Inside reverse-fold.

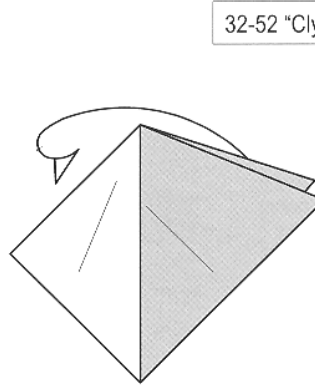

13. Swing the flap at the back to the left.

32-52 "Clydesdale Horse"

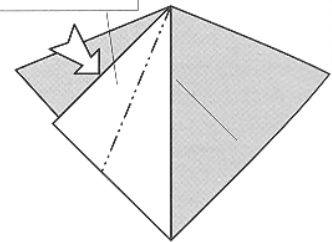

14. Complete steps 32 to 52 of the "Clydesdale Horse" on this part of the model.

Réaliser les étapes 32 à 52 du "Cheval de trait" sur cette partie du modèle.

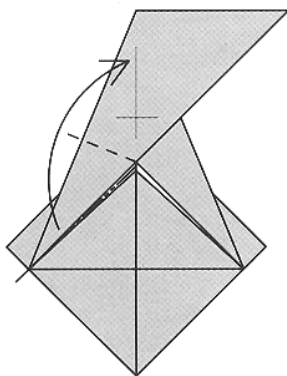

15. Valley-fold the flap up. The model will not lie flat.

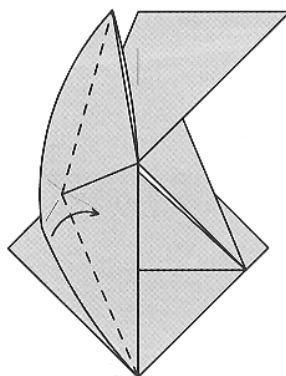

16. Flatten.

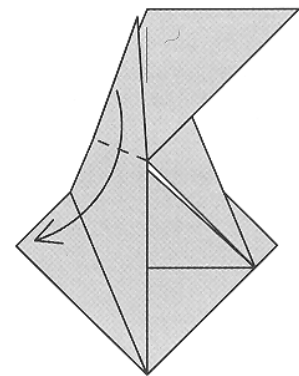

17. Valley-fold the flap down.



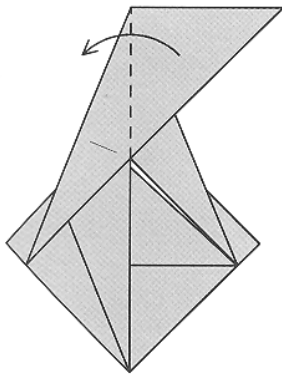

18. Valley-fold to the left.

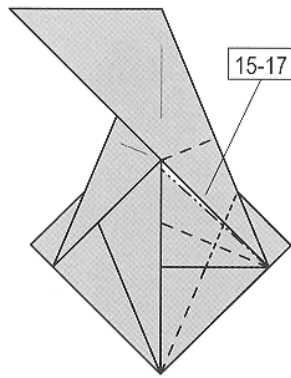

19. Repeat steps 15 to 17 on the right.

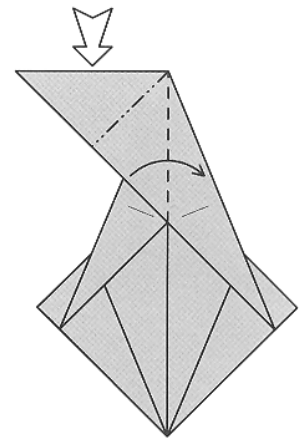

20. Squash-fold.

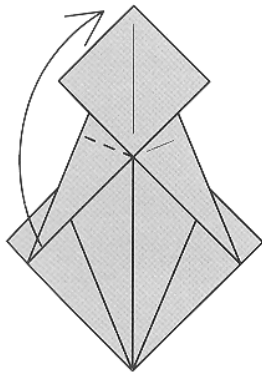

21. Valley-fold the flap up.

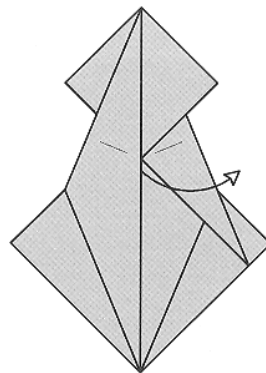

22. Unwrap some paper from inside.

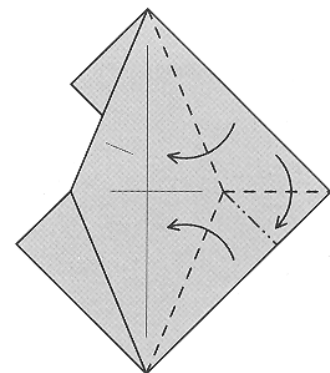

23. Rabbit-ear.

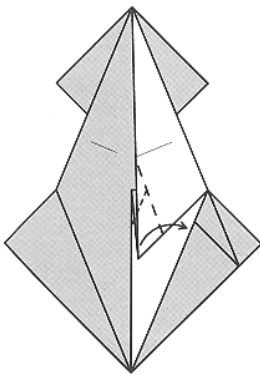

24. Valley-fold.

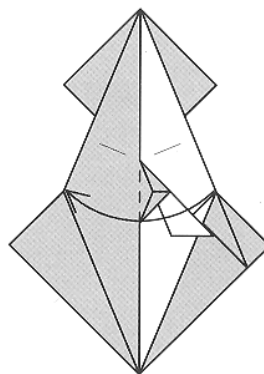

25. Valley-fold the white layer to the left.

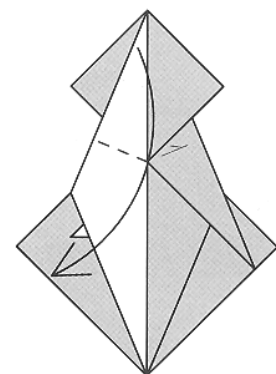

26. Valley-fold the flap down.

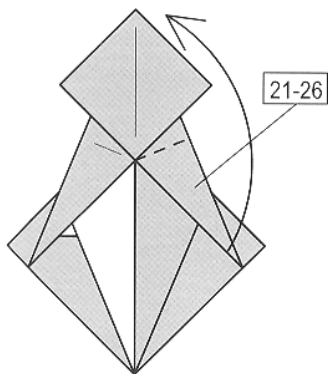

27. Repeat steps 21 to 26 on the right.

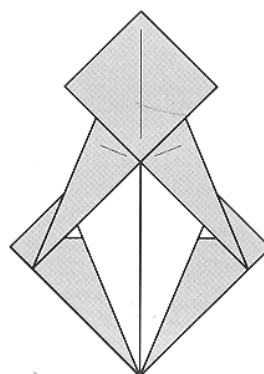

28. Turn over.

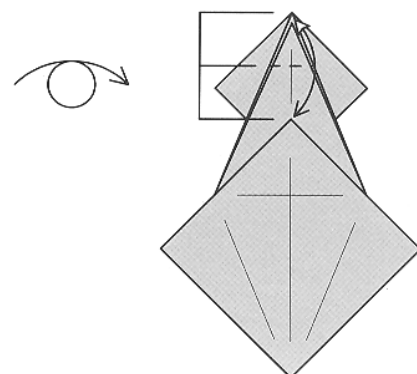

29. Valley-fold and unfold the thick point.



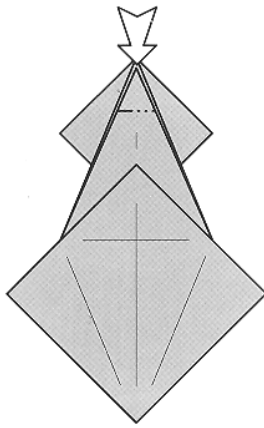

30. Complex open-sink.

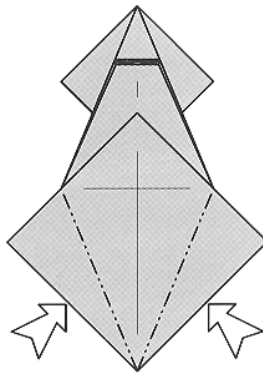

31. Inside reverse-folds on existing creases.

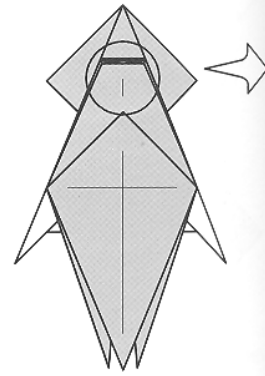

32. Focus on the thick layer.

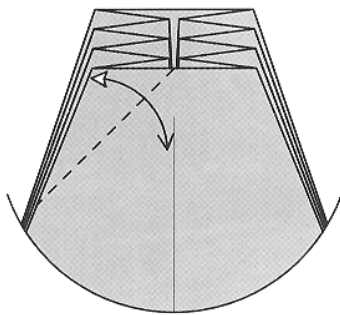

33. Valley-fold and unfold the top layer only.

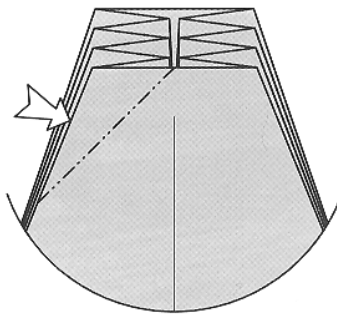

34. Open-sink.

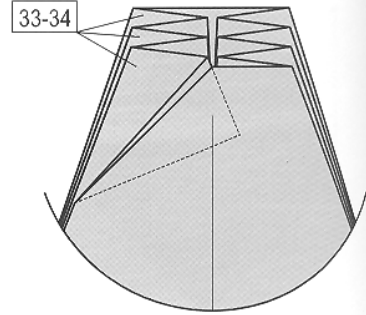

35. Repeat steps 33 to 34 on the other three corners.

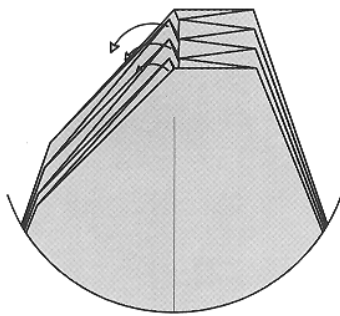

36. Spread the points to the side evenly.

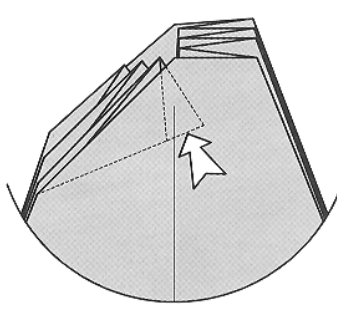

37. Inside reverse-fold to narrow ALL the teeth.

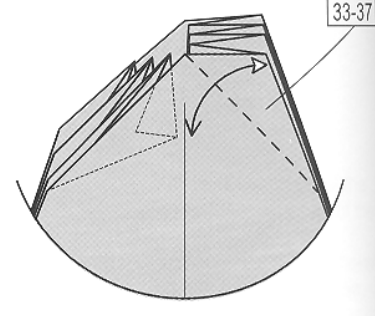

38. Repeat steps 33 to 37 on the right.

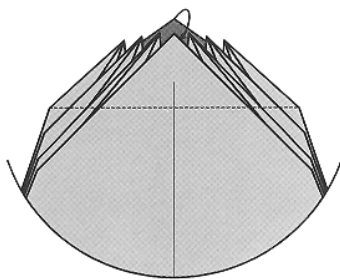

39. Valley-fold the furthest point down into the layers.

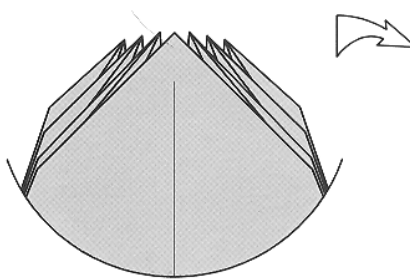

40. Back to original scale.

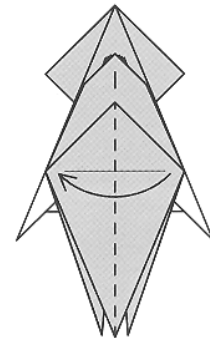

41. Valley-fold one layer.



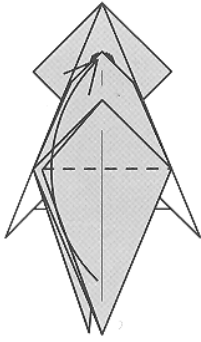

42. Valley-fold the flap up.

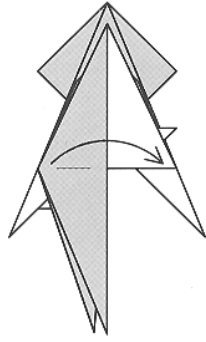

43. Valley-fold one layer to the right.

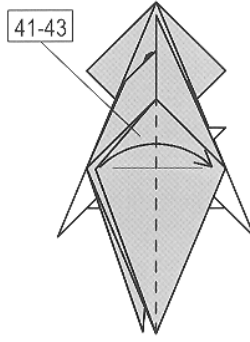

44. Repeat steps 41 to 43 on the left.

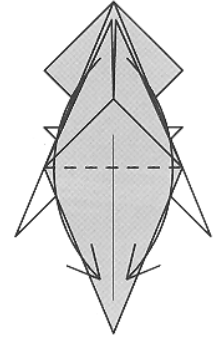

45. Valley-fold both flap down.

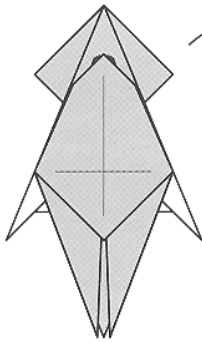

46. Turn over.

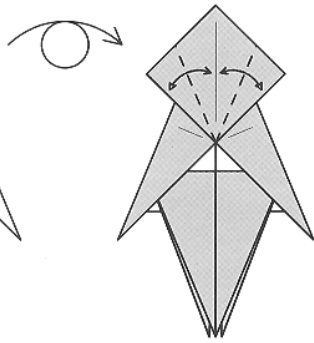

47. Valley-fold and unfold.

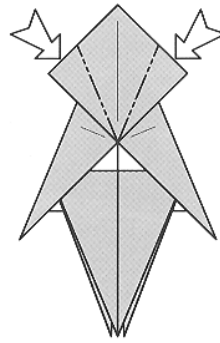

48. Inside reverse-folds.

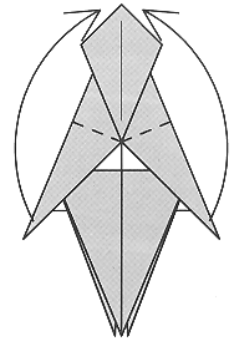

49. Valley-fold both flaps up.

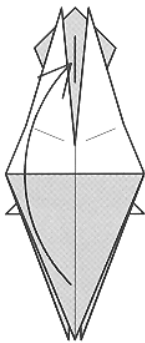

50. Valley-fold the flap up.

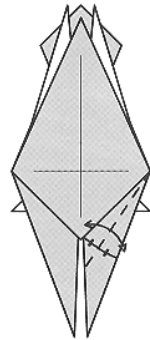

51. Valley-fold and unfold two layers to the front and two layers to behind.

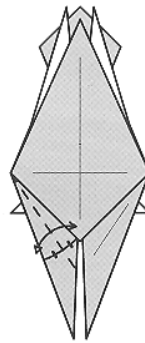

52. Repeat step 51 on the left.

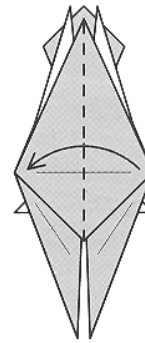

53. Valley-fold two layers to the left.

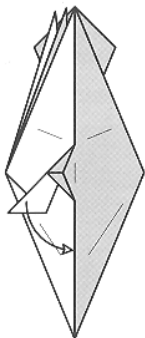

54. Unfold the fin.

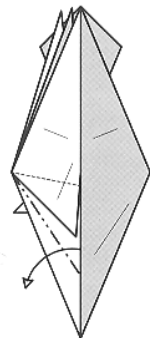

55. Pull out the raw edge on existing creases.

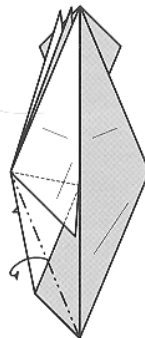

56. Mountain-fold into the layers underneath.

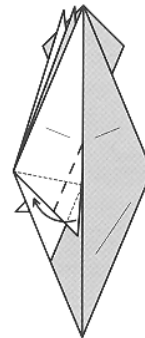

57. Re-fold the fin.



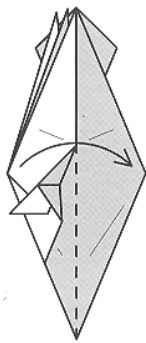

58. Valley-fold two layers to the right.

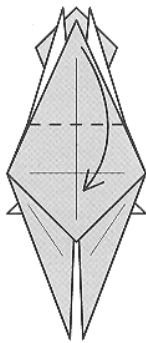

59. Valley-fold. See next step.

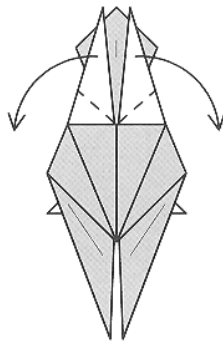

60. Valley-folds.

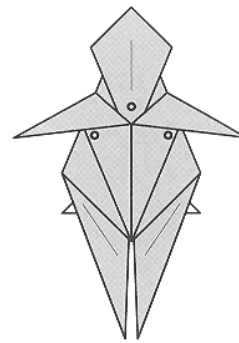

61. Bring the marked corners forward.

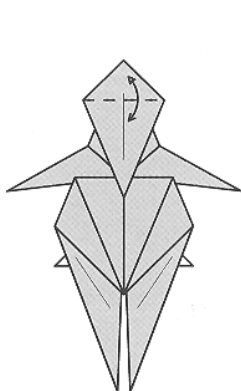

62. Valley-fold and unfold.

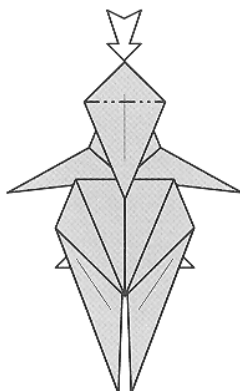

63. Open-sink.

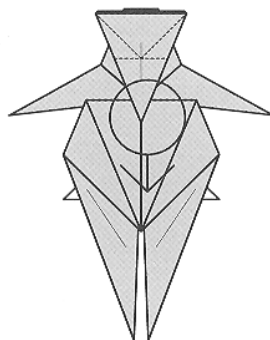

64. Stretch-fold the raw corner down as far as possible.

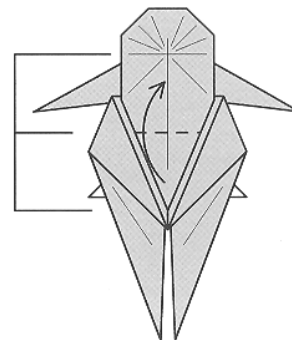

65. Valley-fold.

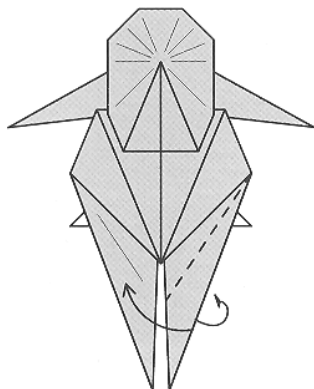

66. Outside reverse-fold symmetrically. Use existing creases.

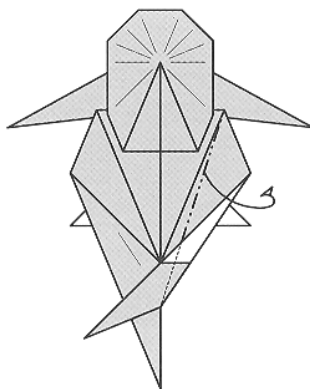

67. Mountain-fold the coloured layer only.

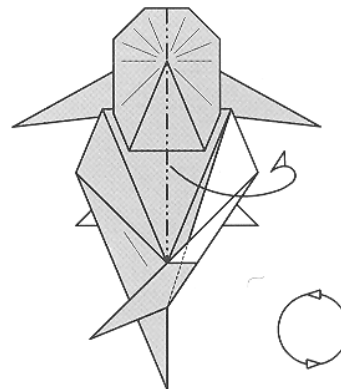

68. Mountain-fold the model in half. Be careful not to tear! Rotate.

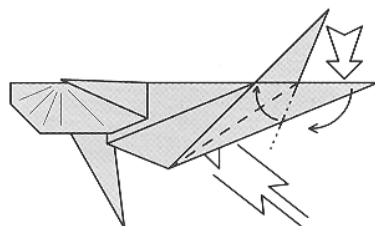

69. Outside crimp-fold symmetrically. Use existing creases.

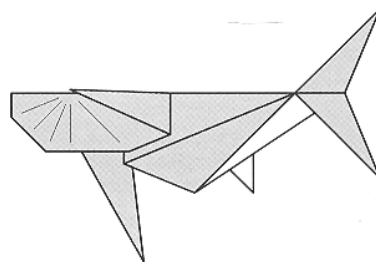

70. Make sure the rear layers of step 69 are tucked into the layers of the upper tail fin to lock the tail.

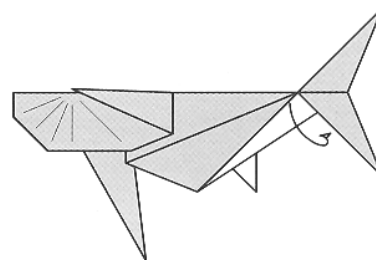

71. Mountain-fold the white layer behind.



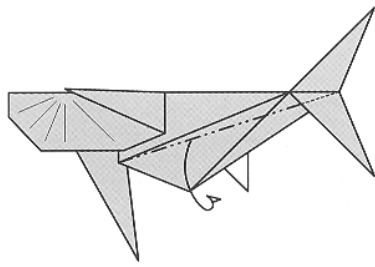

72. Mountain-fold the coloured layer only.

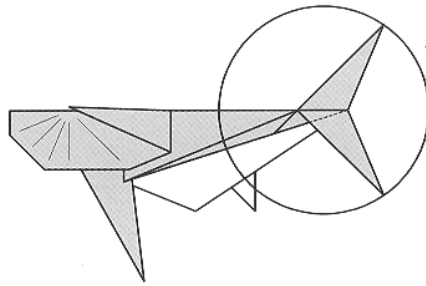

73. Detailed view.

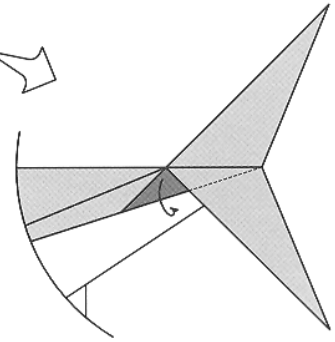

74. Mountain-fold the layer behind.

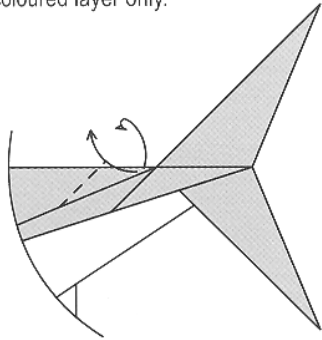

75. Outside reverse-fold the raw corner.

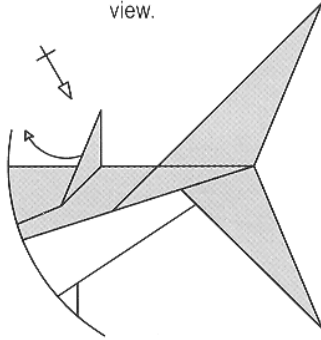

76. Pull out the raw edge. Repeat behind.

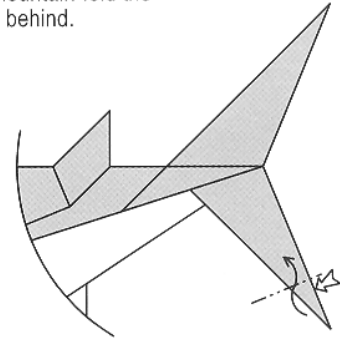

77. Inside reverse-fold.

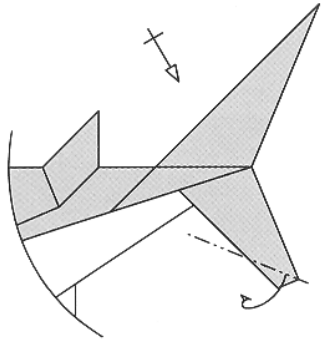

78. Mountain-fold. Repeat behind.

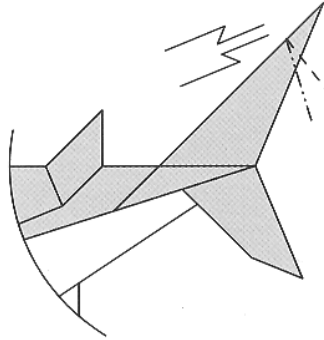

79. Inside crimp-fold.

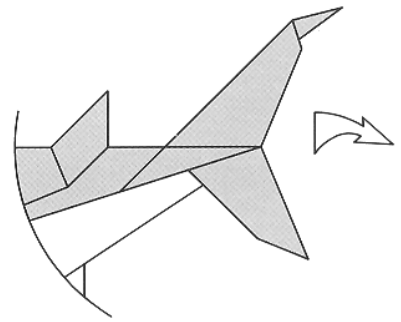

80. Back to original scale.

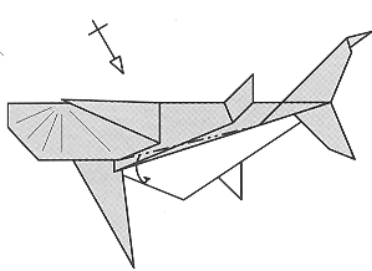

81. Mountain-fold. Repeat behind.

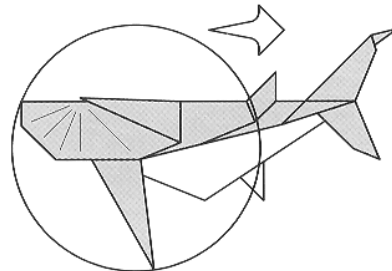

82. Detailed view.

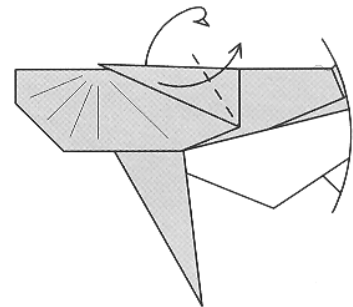

83. Outside reverse-fold.

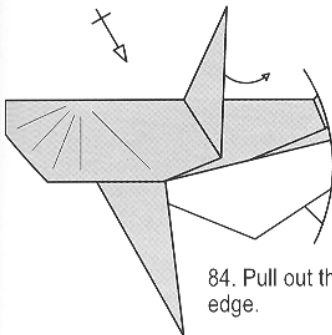

84. Pull out the raw edge.

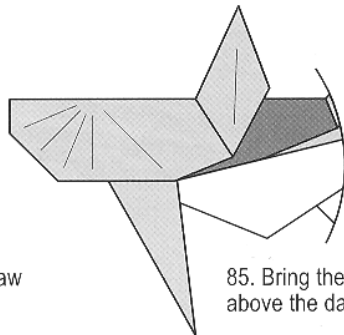

85. Bring the pectoral fin above the darker area.

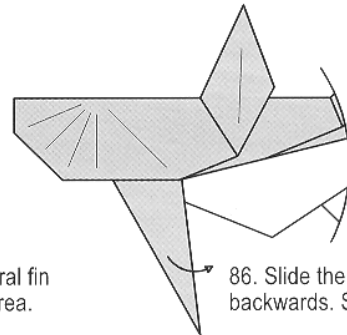

86. Slide the pectoral fins backwards. See next step.



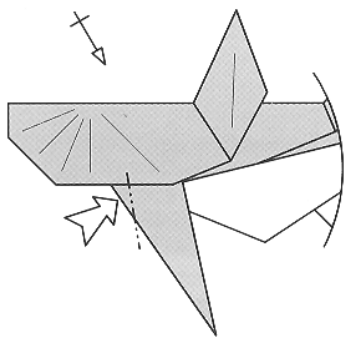

87. Inside reverse-fold.  
Repeat behind.

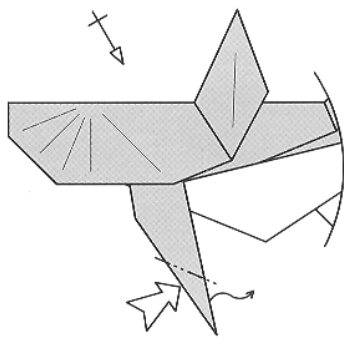

88. Inside reverse-fold.  
Repeat behind.

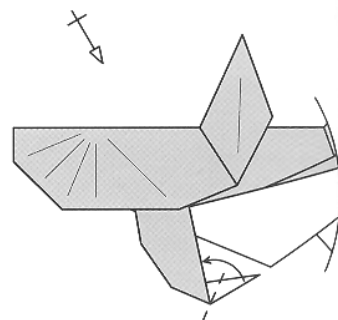

89. Valley-fold.  
Repeat behind.

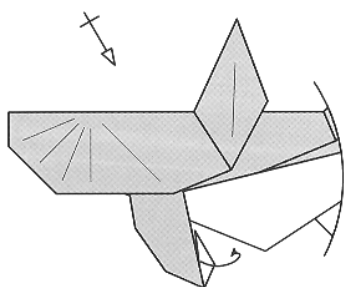

90. Mountain-fold inside.  
Repeat behind.

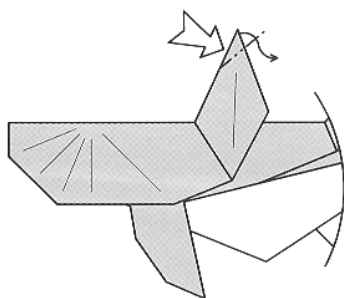

91. Inside reverse-fold.

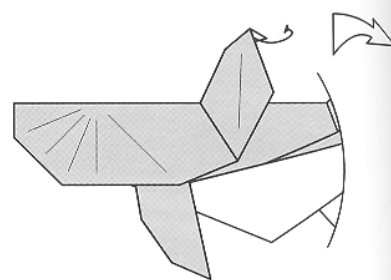

92. Mountain-fold the white tip inside.  
Back to original scale.

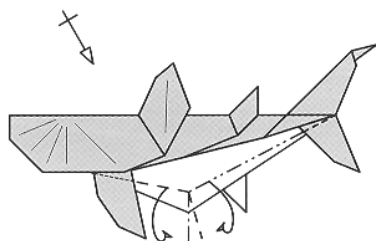

93. Rabbit-ear. Repeat behind.

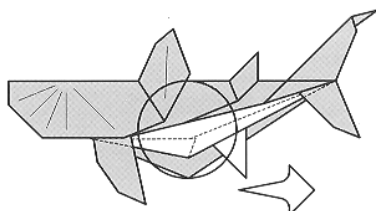

94. Detailed view.

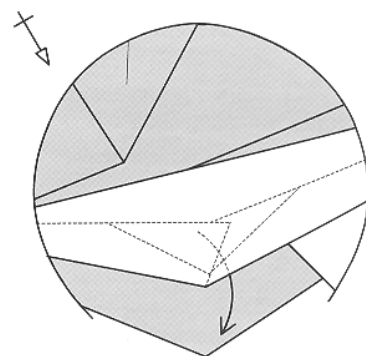

95. Valley-fold the raw corner down from inside.  
Repeat behind.

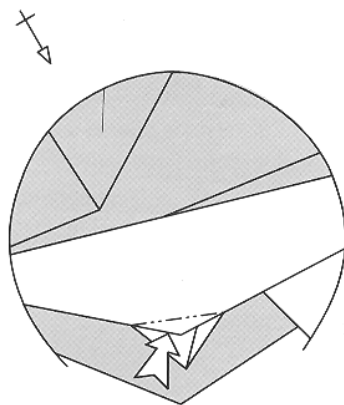

96. Mountain-fold or closed-sink.  
Repeat behind.

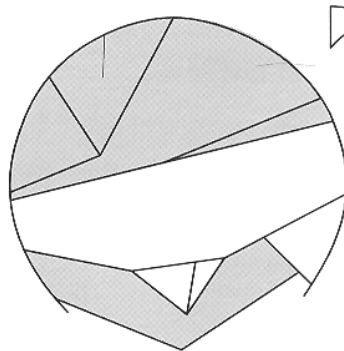

97. Back to original scale.

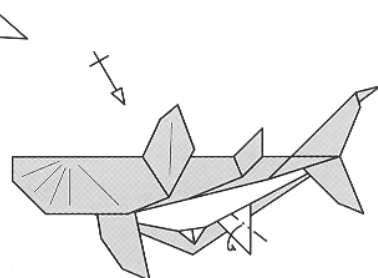

98. Mountain-fold. Repeat behind.





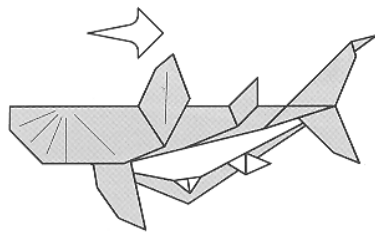

99. Detailed view.

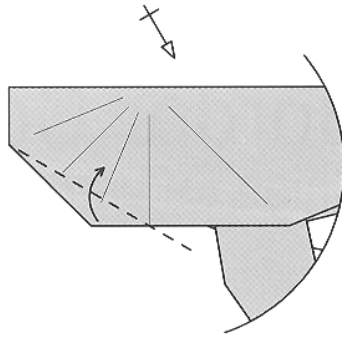

100. Valley-fold. Repeat behind.

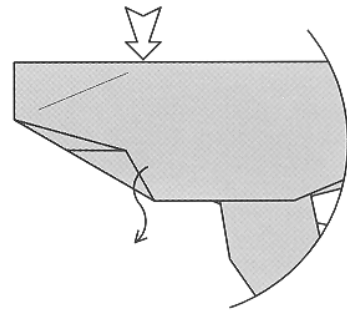

101. Reverse-fold the thick internal flap down.

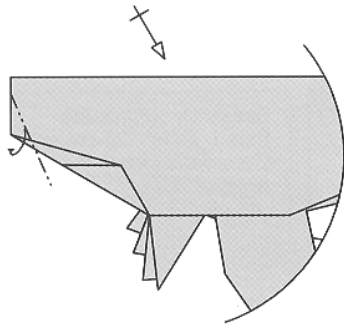

102. Mountain-fold. Repeat behind.

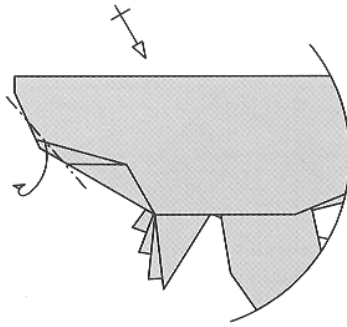

103. Mountain-fold. Repeat behind.

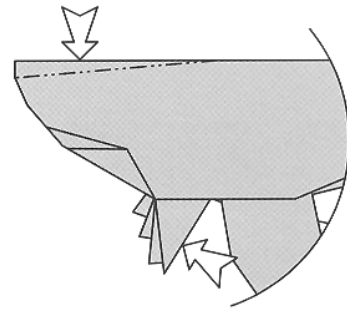

104. Flatten out the top and lower jaws.

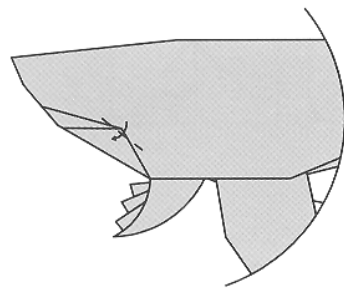

105. Form the eyes.

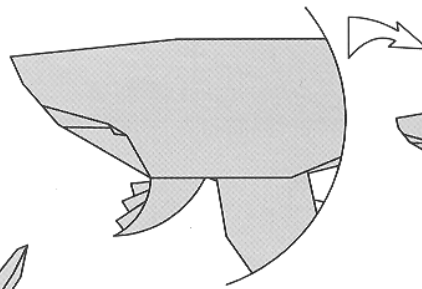

106. Back to original scale.

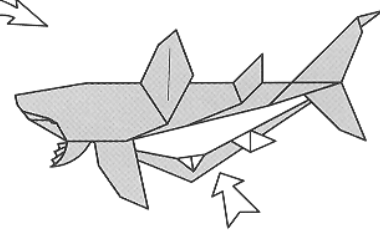

107. Curl the coloured layers in to close the body.

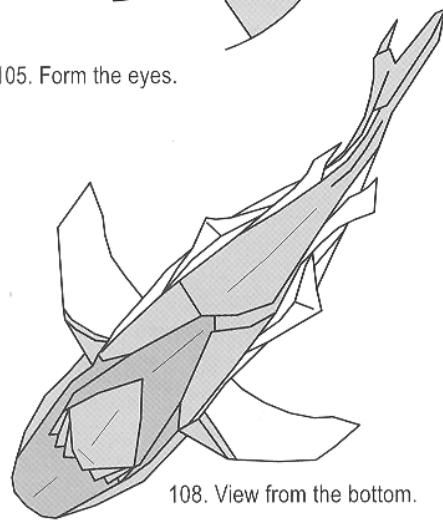

108. View from the bottom.

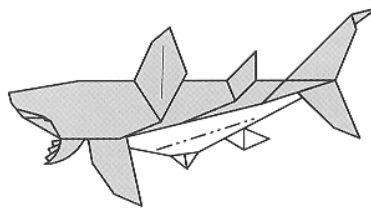

109. Round the body.

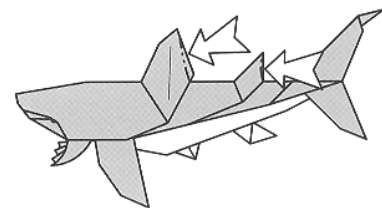

110. Shape the dorsal fins.

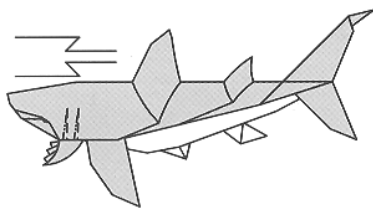

111. Form the gills with crimp-folds if you can!

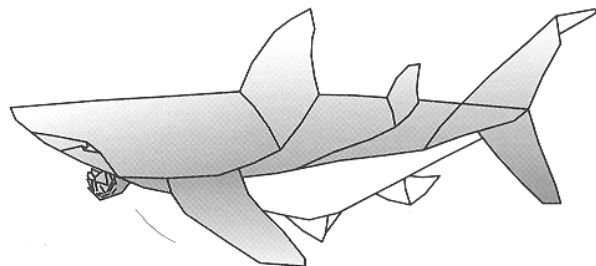

Great White Shark.

