

犬 Dog

創作 Created 2003/2 改良 Revised 2009

難易度 Difficulty ★★★★★

使用紙サイズ Paper Size 24×24cm

折り図初出 First Published

『折紙探偵団』80号(2003, 日本折紙学会)

"Origami Tanteidan Magazine" No.80 (2003, JOAS)

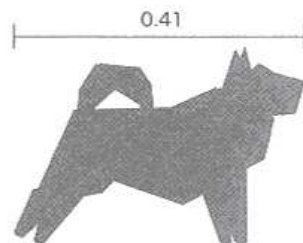
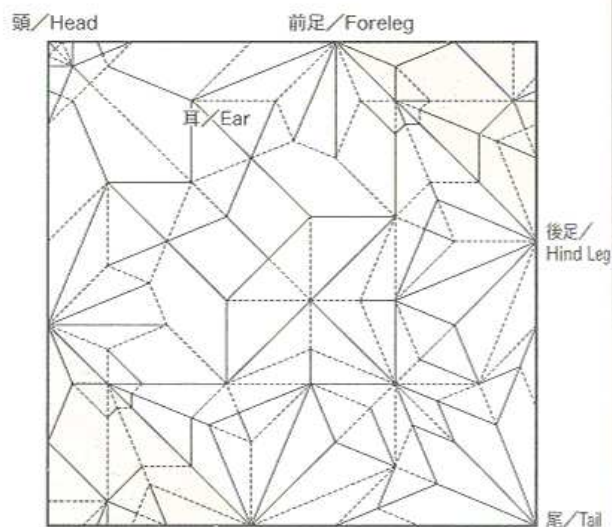
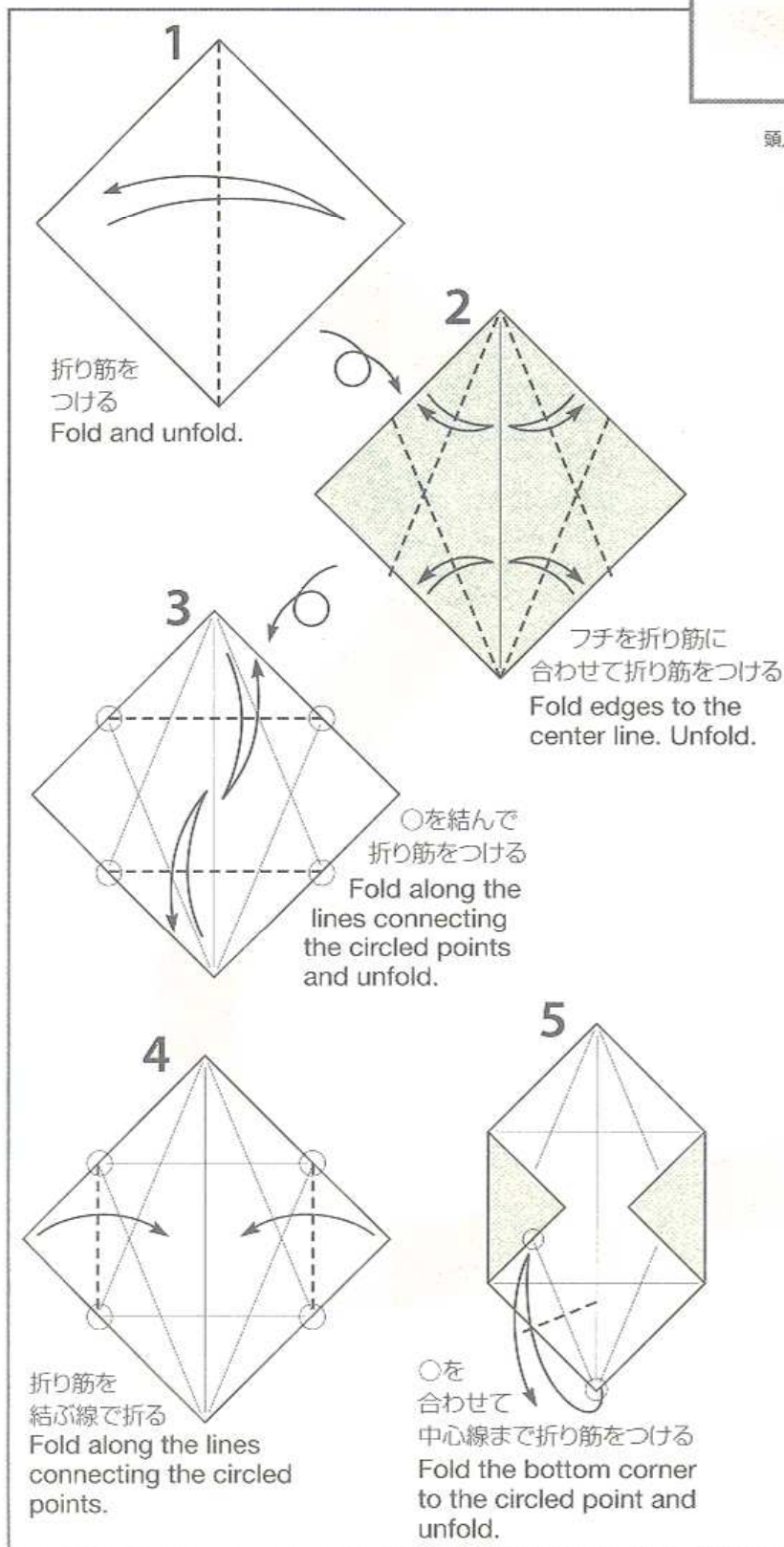
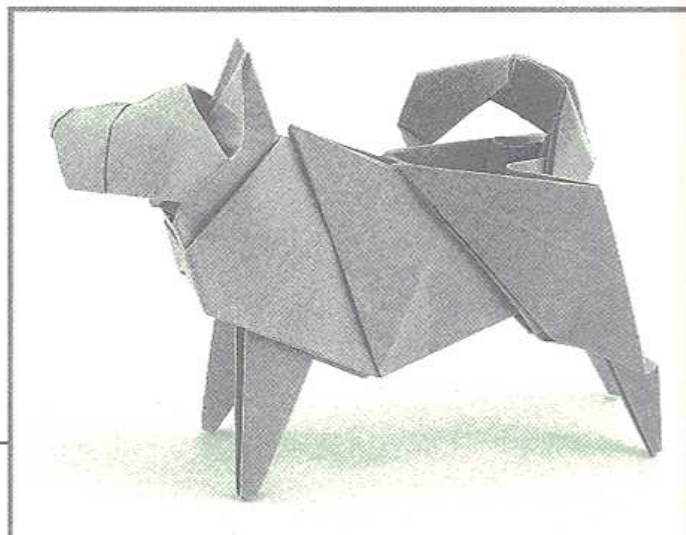

16

14~15と同様に
折り筋をつける
Repeat 14-15
on the left.

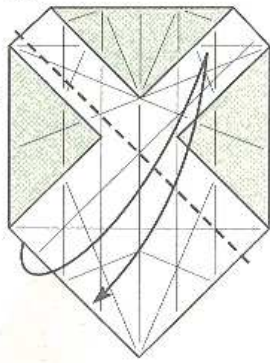

17

○を通る線で
折り筋をつける
Fold and unfold
at the central
cross point.

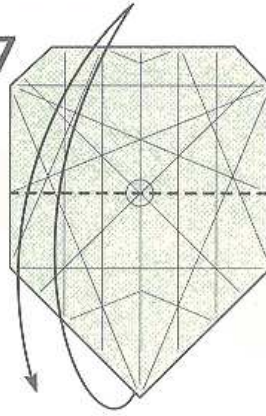
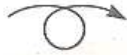

18

○を
合わせて折る
Fold aligning
the circled points.

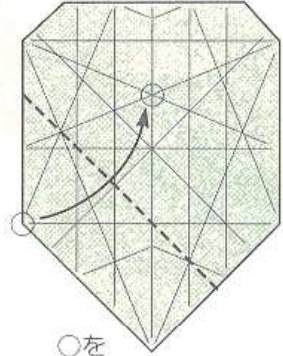

15

折り筋をつけて
戻す
Unfold.

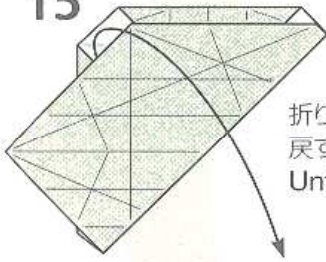

14

○を
合わせて折る
Fold aligning
the circled points.

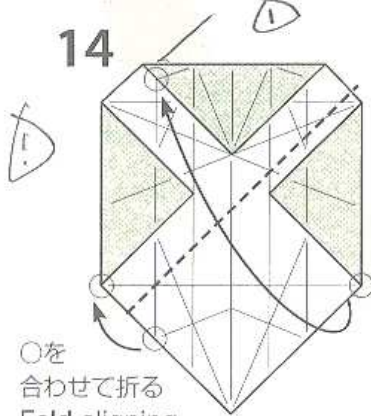

13

カドを○に
合わせて折る
Fold the corner
to the cross.

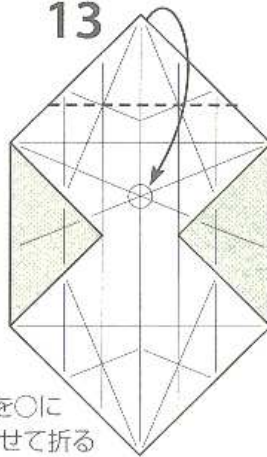

12

カドを
合わせて
折り筋をつける
Fold and unfold
corner to corner.

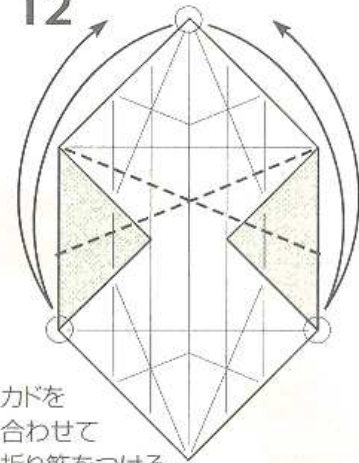

8

カドを結ぶ線で折り返す
(内側のカドもひらかずに折る)
Fold the edges to the left.
Fold the inner layers together.

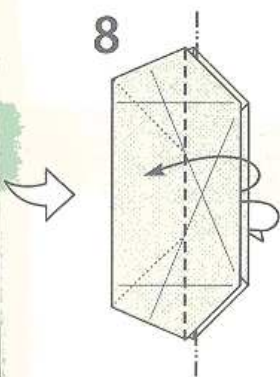

9

ひらく
Open the model.

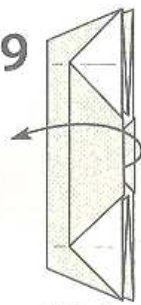

10

後ろの
紙を出しながら
フチを中心線に
合わせて折る

Fold edges to
the center
swiveling the
layers behind.

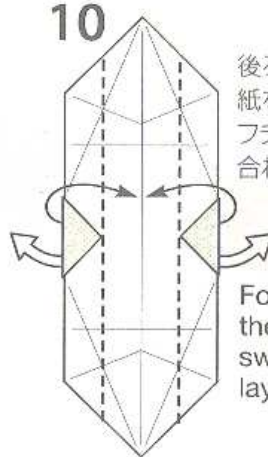

11

折り筋を
つけたらひらく
Open the model.

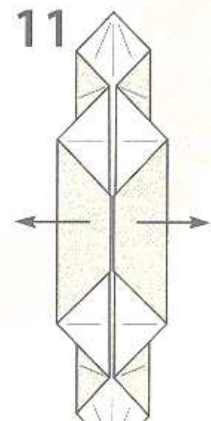



戻す
Unfold.

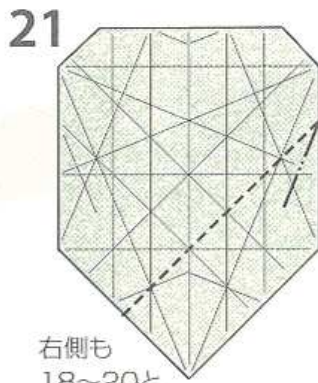

右側も
18~20と
同様に折り筋をつける
Repeat 18-20 on
the right.

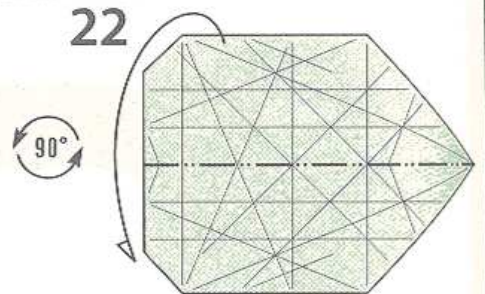

90°

後ろへ半分に折る
Fold the model in half.



フチを
合わせて
三角のところに
だけ折り筋をつける
(紙がずれないように注意)

Fold edge to edge,
but crease only the colored part.
(Fold as precisely as possible)

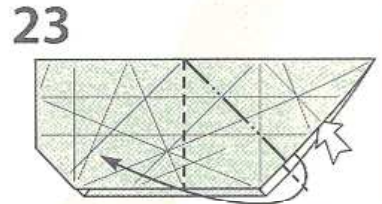

ついている折り筋で
内側をひろげてたたむ
Open the layer and
squash using the
crease lines.

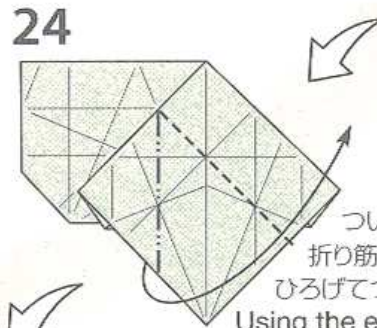

ついている
折り筋で内側を
ひろげてつぶすように折る
Using the existing
crease lines, fold the layer up and
swivel the raised edge.

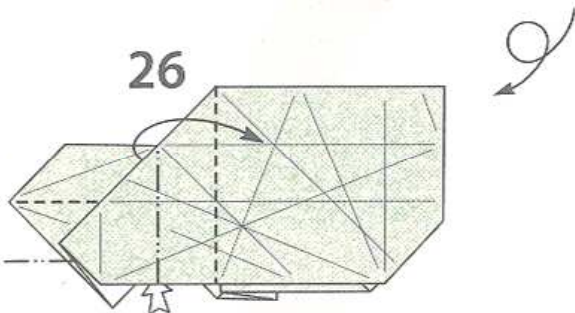
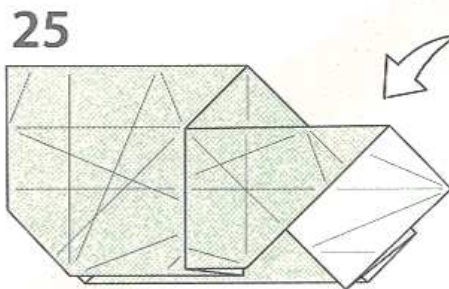

引き寄せるように
内側をひろげてつぶす
Pleat and swivel
the edge.

この部分は立体的に
なっている
This part should
not be flattened.

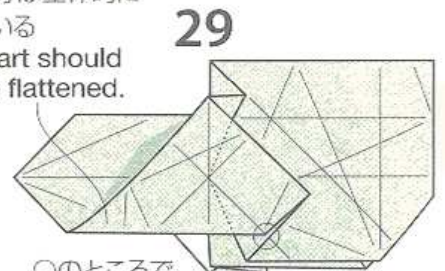

○のところで
折り筋が合っていることを確認してつぶす
Make sure that crease lines are
straight at the circled point.
Squash and flatten.

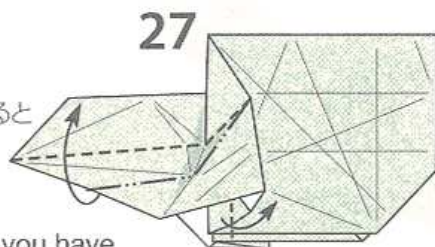

(途中の図)
この工程を折ると
全体が表裏で
対称になる
(In process)
Fold up and you have
the model symmetrical.

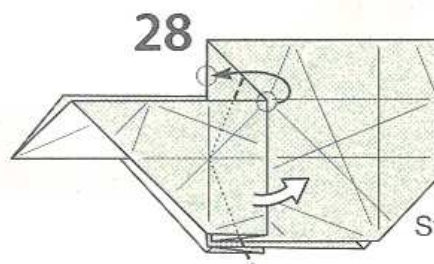

○を合わせて
回転させる
ように折る
Swivel the flap.

37

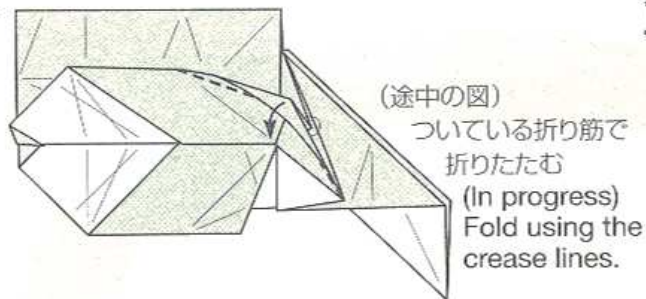

38

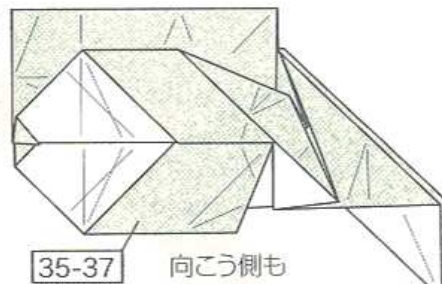

36

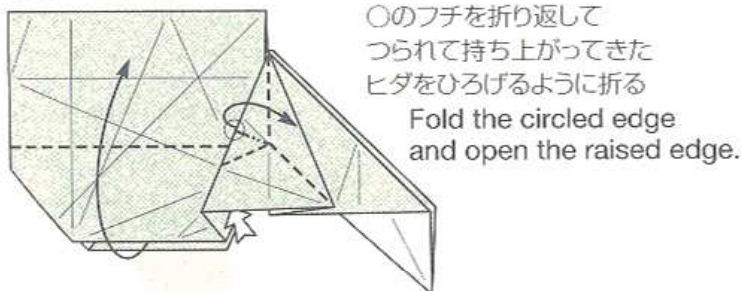

39

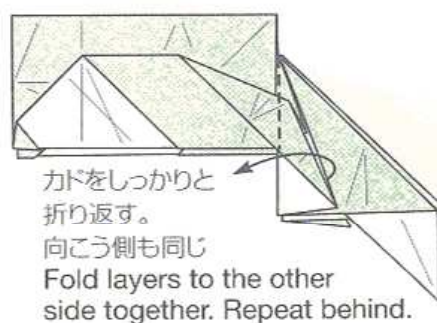

35

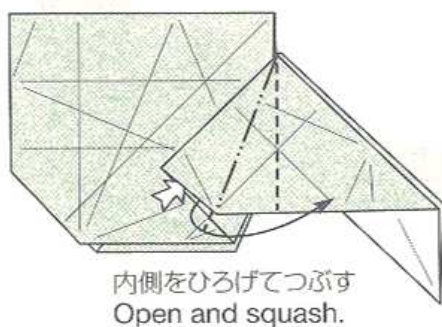

34

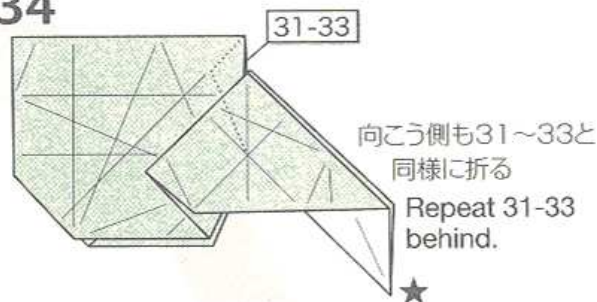

30

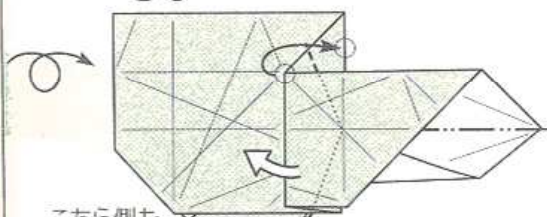

33

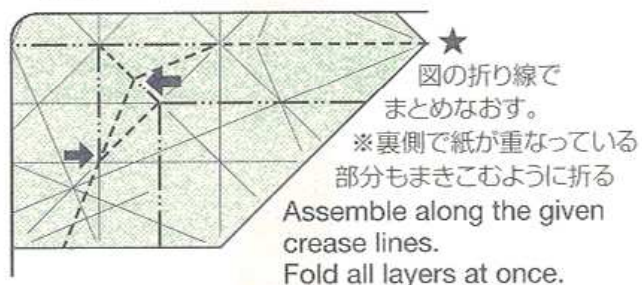

31

カドを反対側に
引き出して
折り筋をしっかり
つける
Pull out the
corner and
crease tightly.

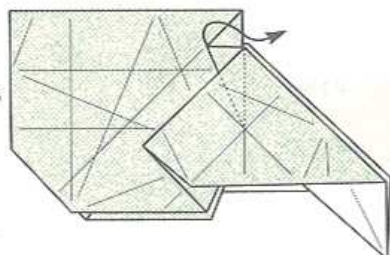

32

押し込むように沈め折り
(closed sink)。
次の図のようにいったん
かるくひらいて折ると
きれいに折れる
Push in the corner
(closed sink).
Refer to 33 to do
this precisely. ★

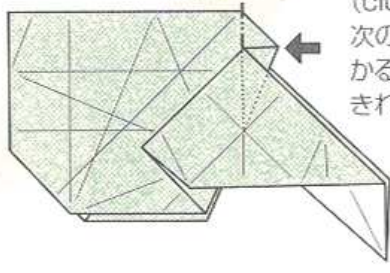

41

ついている
折り筋で内側に
引き寄せ折り。向こう側も同じ
Fold the corner inside using
the crease lines. Repeat behind.



42

カドのすき間を
ひらいて折り返す
Open the layers.

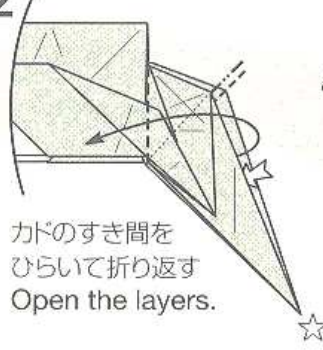

43

持ち上がったカドを
つまんでたおす
Raise and fold
the corner in half
and flatten it to
the right.

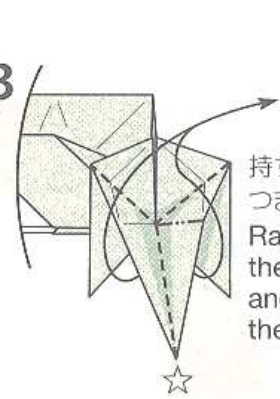

40

ずらすように折る。
向こう側も同じ
Swivel the edge.
Repeat behind.

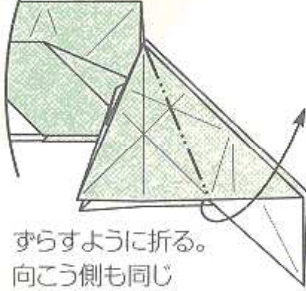

44

カドの根元に
折り筋をつける
Fold the flap
to the left
and unfold.

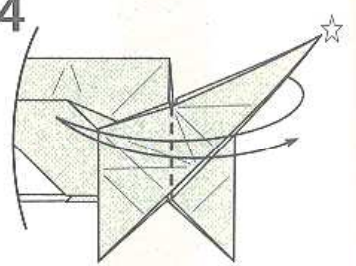

46

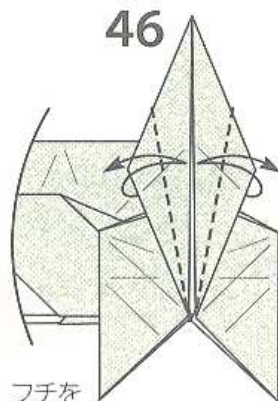

フチを
合わせてしっかりと折り筋をつける
Fold the edges to the center.
Crease tightly and unfold.

45

内側をひろげて
左右対称につぶす
Open and squash.

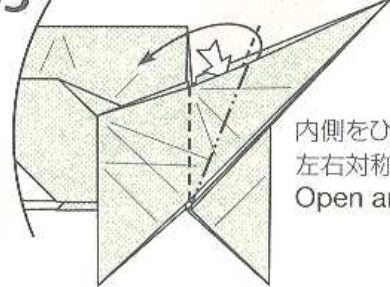

47

つけた
折り筋で沈め折り
(closed sink)
Closed sink using
the crease lines.

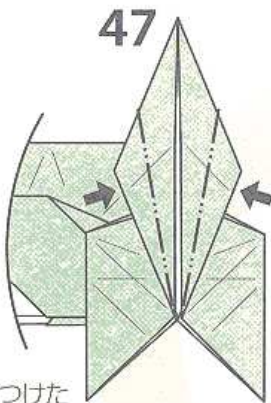

48

段になっている
部分をひらいて
見る
Extend the layers
under the top layers.

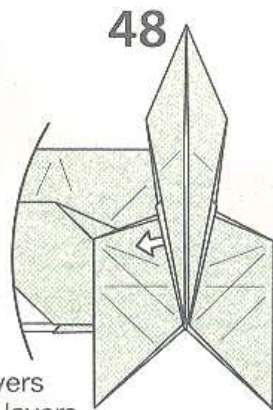

49

ついている
折り筋で両側で段折り
(ひらいて折ると良い)
Crimp using the crease lines.
(Open the layers will help)

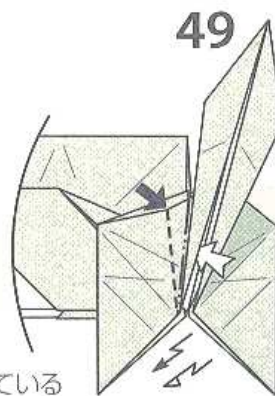

50

(途中の図)
(In process)

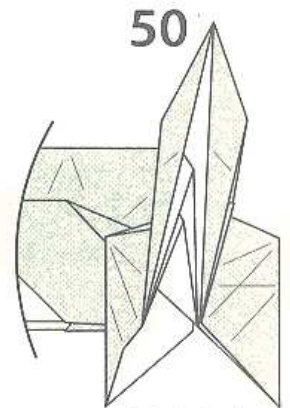

58

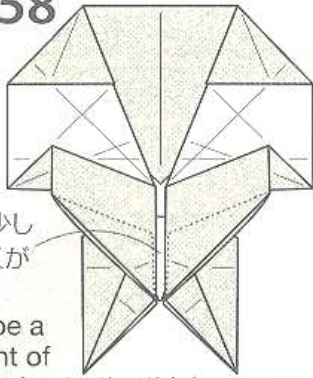

紙の厚みで少し
すき間があくが
問題ない

There will be a
little amount of
space here due to the thickness
of paper, but don't worry about that.

59

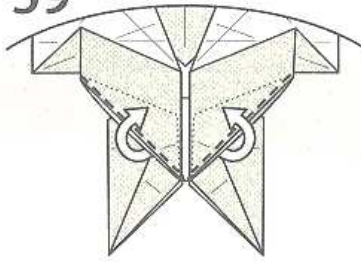

後ろにあるカドを手前に
出すように折り変える
Pull out the hidden
layers.

60

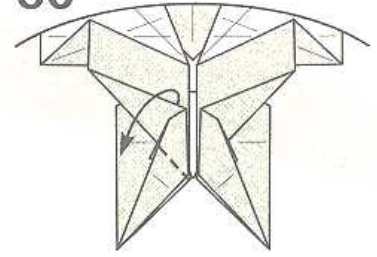

左側だけ折り返す
Fold down the
left layer.

57

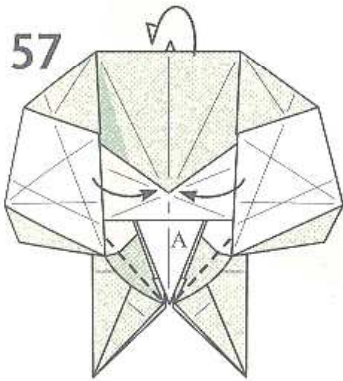

(途中の図)

Aのカドが左右に
ひらいてあること

(In process)

Note that the white
area A is squashed.

56

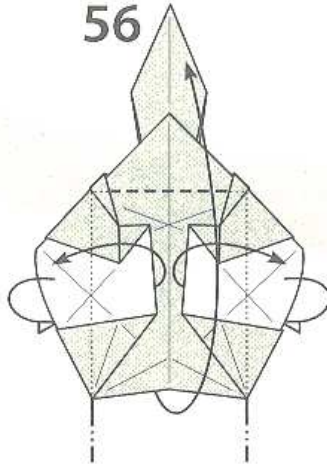

左右のフチをひらきながら
ついている折り筋で折り上げる
Open the layers on sides and
fold up using the crease line.

55

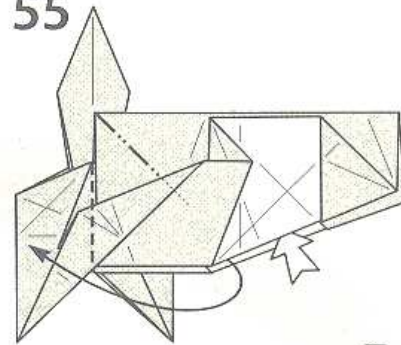

内側を真ん中でひらく
Open and squash
the top layers.

54

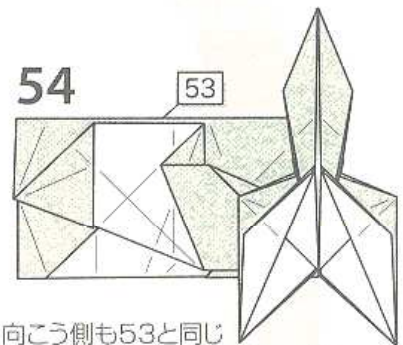

向こう側も53と同じ
Repeat 53 on the other side.

51

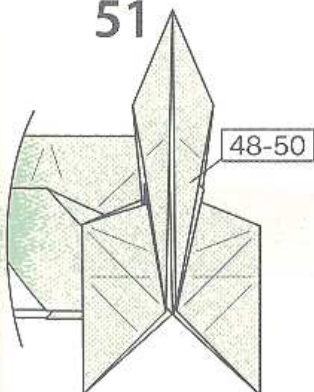

右側も48~50と同じ
Repeat 48-50 on
the right.

52

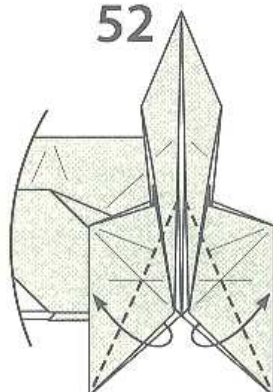

フチを合わせて折る
Fold edge to edge.

53

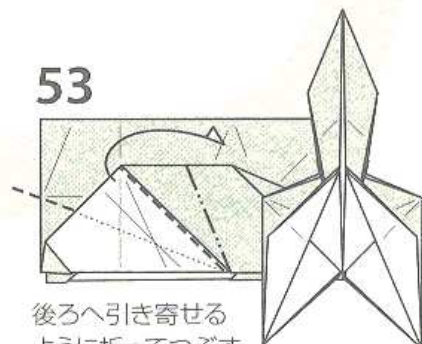

後ろへ引き寄せる
ように折ってつぶす
Swivel inside and flatten the
end of the flap.

62

カドを折り返す
Fold up the
left layer.

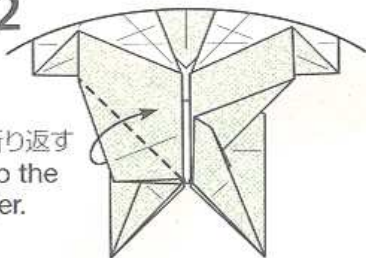

63

右側のカドはそのまま
Keep the right layer
intact.

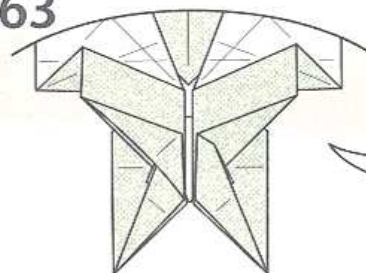

64

すぐ後ろにあるフチの
ところで引き寄せ折り
Swivel fold, folding
along the edge
behind.

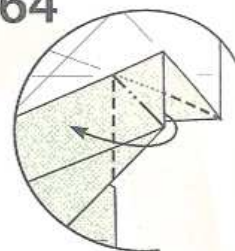

61

ヒダを
向こう側に
かぶせるように裏返す。
いったん紙をひらいて折ると良い
Wrap a layer around to behind.
Opening the layers a little will help.

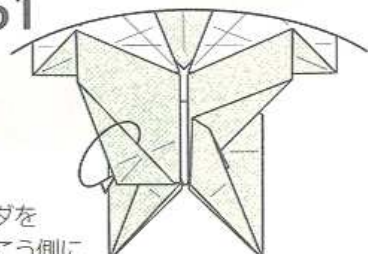

65

後ろにある紙を
手前に折り変える
Pull out the hidden
layers.

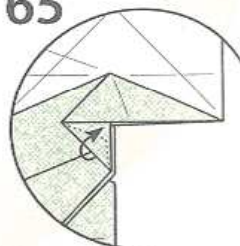

66

左側も
64~65と同じ
Repeat 64-65
on the left.

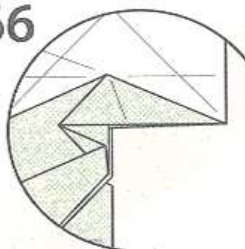

67

左側のみ後ろの
フチをかぶせる
ように折る
Wrap around the
layer behind the
left layer onto it.

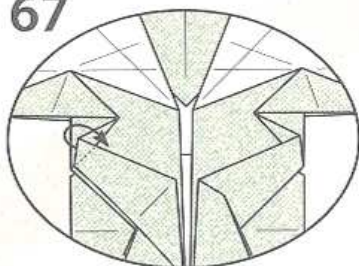

68

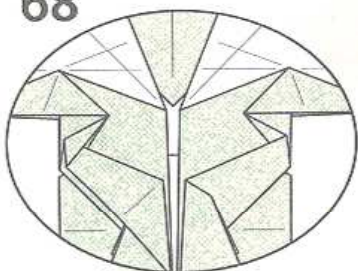

69

重なっている紙を
引き出して折りたたむ
Pull out the hidden
layers.

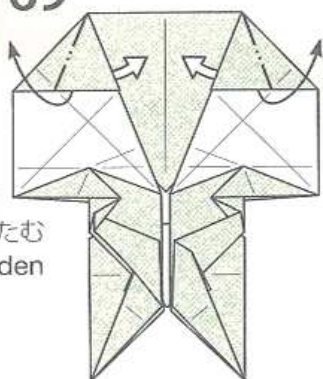

70

○を結ぶ線で折る
Fold along the line
connecting circled
points.

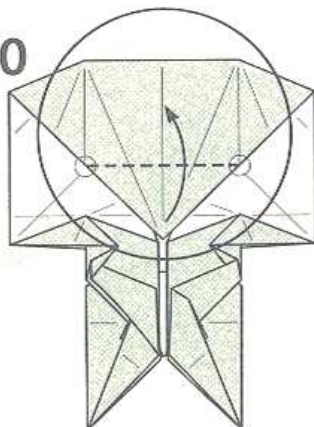

71

フチに合わせるように
つまみ折り
Rabbit ear fold along
the edge.



80

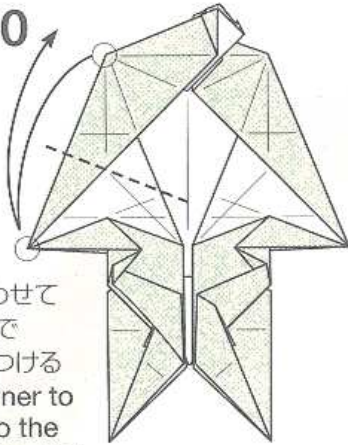

カドを合わせて
中心線まで
折り筋をつける
Fold corner to
corner to the
center line and
unfold.

81

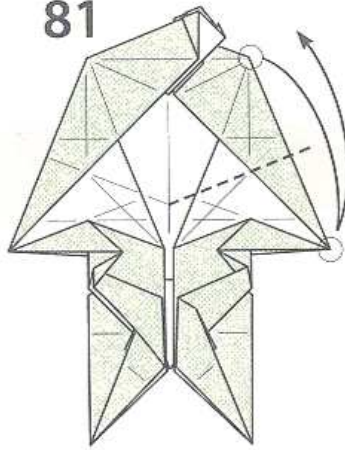

右側も80と同様に
折り筋をつける
Repeat 80 on the
other side.

82

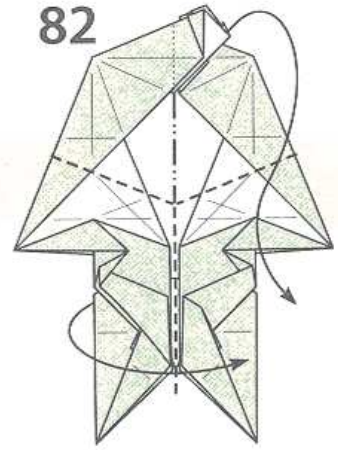

つけた折り筋で上のカドを
折り下げながら全体を半分にする
Fold the model in half,
lowering the top layer using
the crease lines just made.

79

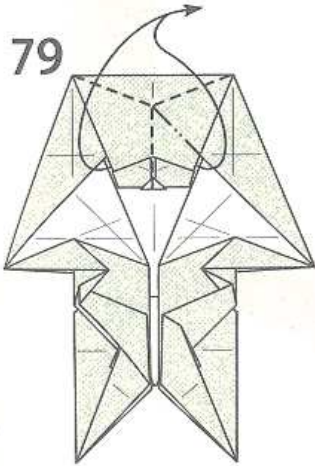

ひらくところでカドを
つまむように折る
Raise and fold the
flap in half.

78

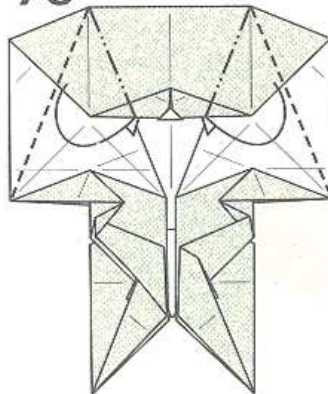

ついている折り筋を使って
内側に引き寄せ折り
Swivel fold using the
crease lines.

77

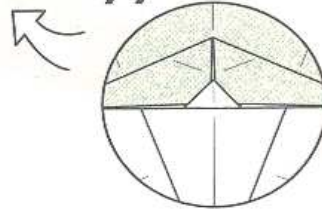

76

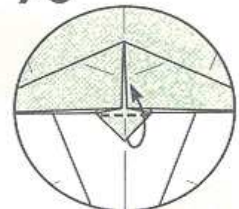

フチのところで折る
Fold up along the
edge.

72

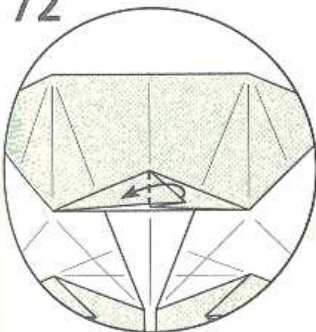

カドを折り返す
Fold the flap to
the other side.

73

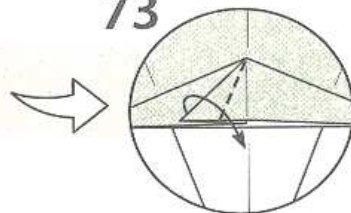

フチを折り筋に
合わせて折る
Fold the edge
to the center line.

74

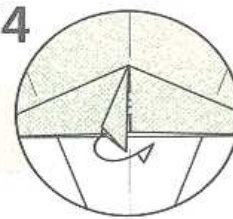

下の1枚を折り返す
Fold the hidden layer
to the other side.

75

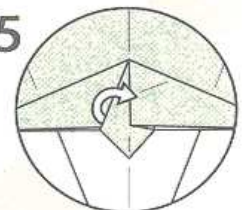

右側と同じ形に
なるよう折り変える
Hide the left layer
as the right one.

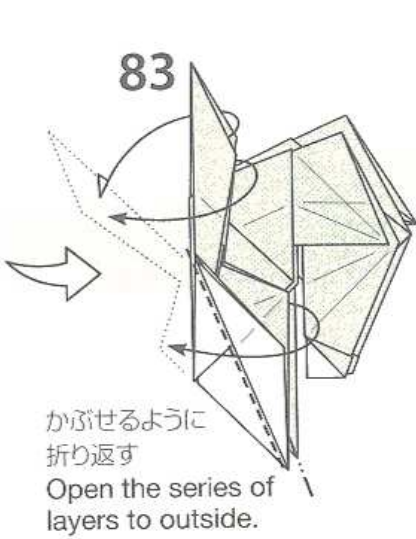

かぶせるように
折り返す
Open the series of
layers to outside.

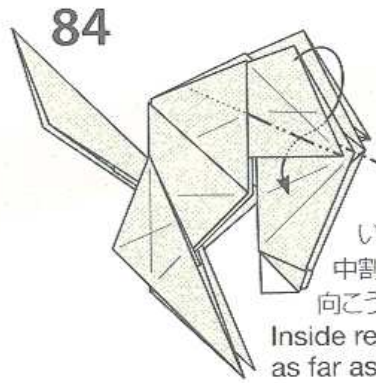

いっぱい
中割り折り。
向こう側も同じ
Inside reverse fold
as far as it goes.
Repeat on the other
side.

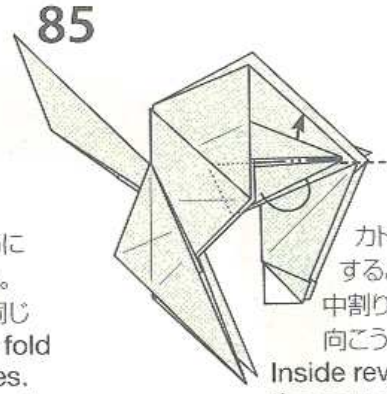

カドを半分
するように
中割り折り。
向こう側も同じ
Inside reverse fold
the corner in half.
Repeat behind.

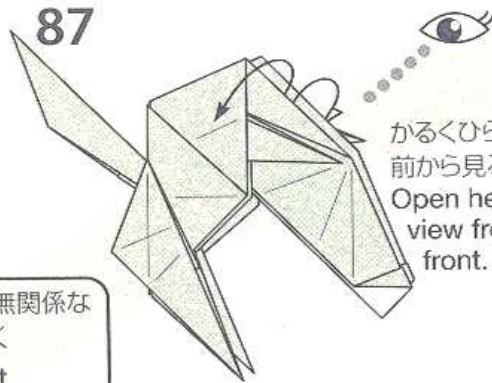

かるくひらいて
前から見る
Open here and
view from the
front.

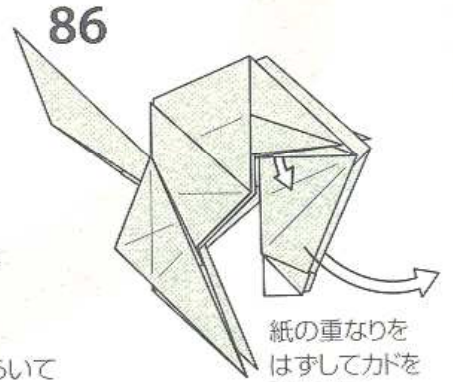

紙の重なりを
はずしてカドを
引き出す
Pull out and raise
the flap.

88~90は工程と無関係な
部分を省略して描く
The relevant part
will be drawn in 88-90.

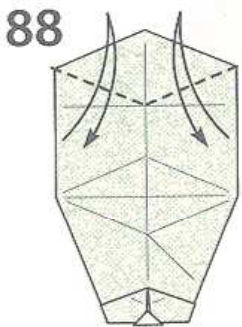

いっぱい
折れるところで
折り筋をつける
Crease at the
furthest point.

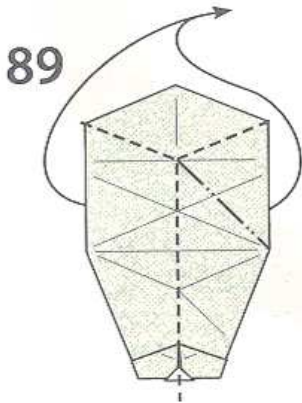
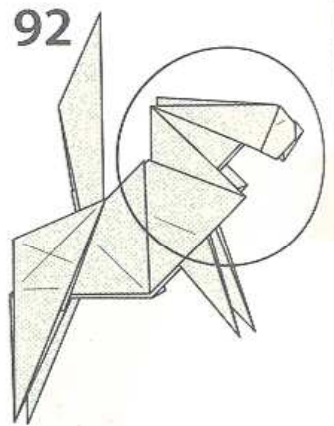

つけた折り筋で
つまむように折る
Rabbit ear fold.

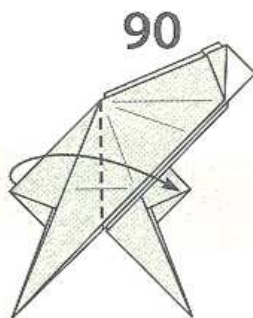

閉じる
Close the model.

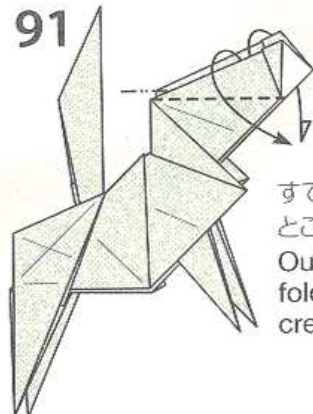

すでにある折り筋の
ところにかぶせ折り
Outside reverse
fold using the
crease lines.

100

折り筋の交点を
結ぶ線で折り返す
Fold down
where the crease
lines cross.

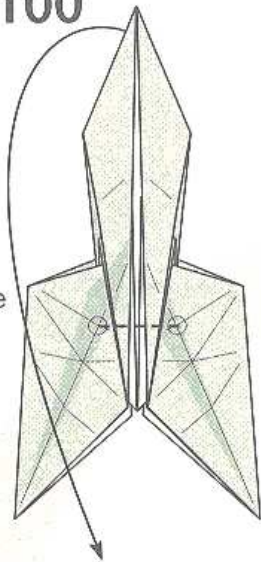

101

かぶせるようにして
カドの向きを変える
When closing the model,
fold up the tail as shown.

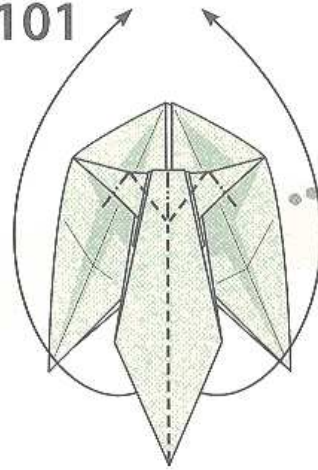

102

(途中の図)
尾が次の図の位置に
くるように折る
(In process)
The tail should look
like this.

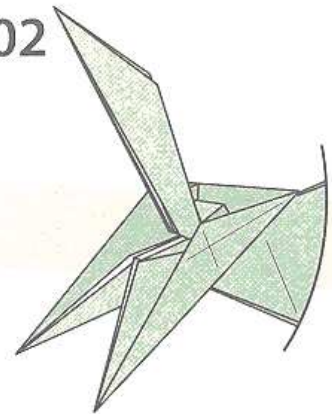

99

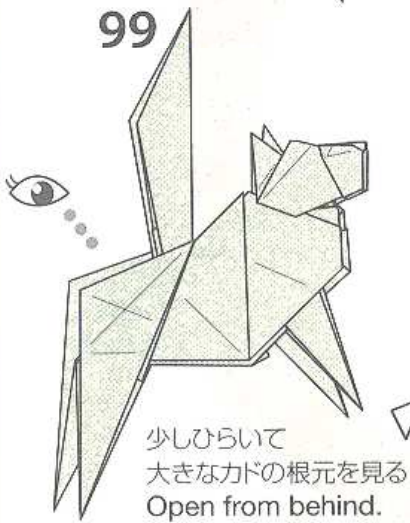

少しひらいて
大きなカドの根元を見る
Open from behind.

98

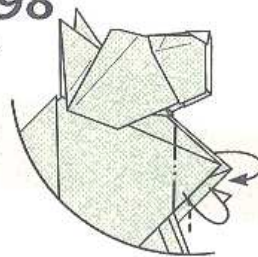

胸のカドを
内側に折り込む
Fold the corners
on the breast inside.

97

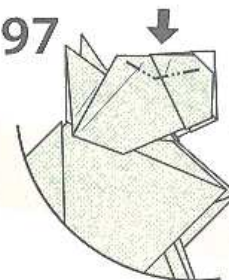

頭を立体的に整える
Shape the head
three-dimensionally.

93

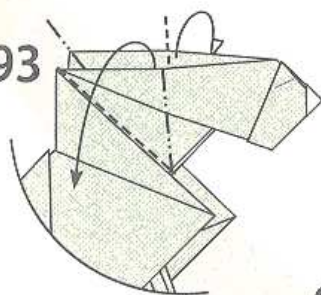

すき間をひらいて
次の図のように折る
Crimp as in 94.

94

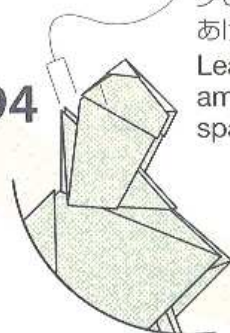

93はここに
少しすき間を
あけるように折る
Leave some
amount of
space here.

95

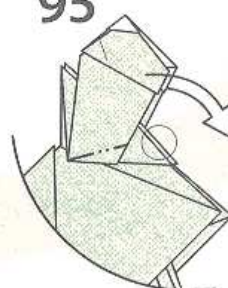

○の部分が
ずれないように
気をつけて、下に
ずらすように折る
Swivel the head,
but keep the circled
edge intact.

96

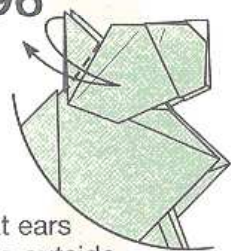

折り筋をつけて
耳が斜めに出る
ようにする。
向こう側も同じ
Crease so that ears
will protrude to outside.
Repeat behind.

103

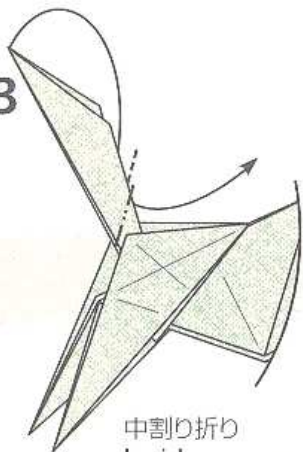

中割り折り
Inside reverse
fold.

104

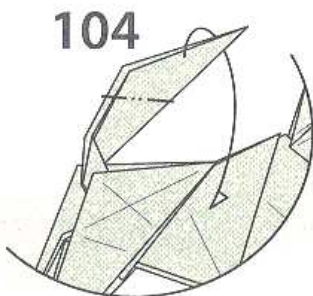

山折り
Mountain fold.

105

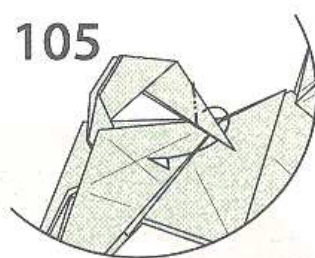

山折り
Mountain fold.

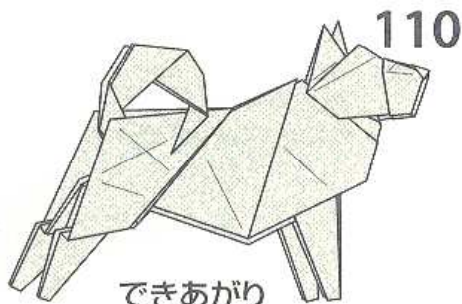

できあがり
Model Completed.

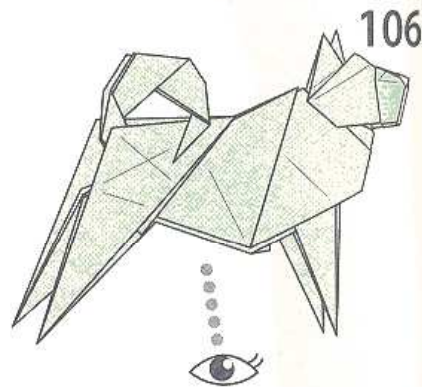

次の図は下から見る
Look from the bottom.

106

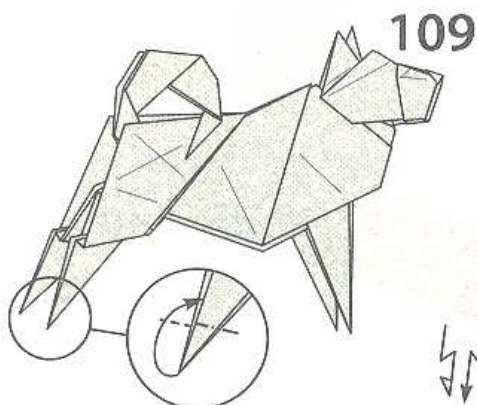

カドの先を少し折り込む。
他の足も同じ
Fold the tip inside.
Repeat on the other legs.

109

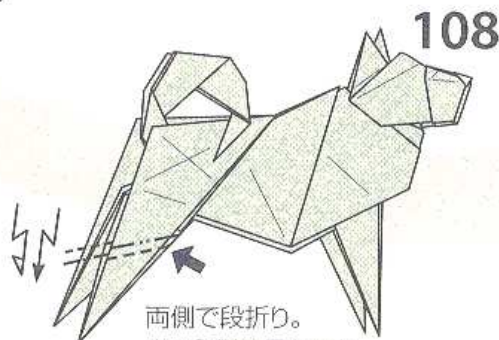

両側で段折り。
向こう側の足も同じ
Pleat on both sides.
Repeat on the other hind leg.

108



下側のカドを
上側のポケットにはめこんで
ひらき留めとする
Insert the circled flap into the
pocket on the other side to
lock the model.

107

普通、谷についている折り筋よりも山のそれの方が、視認しやすくなります。このことは、下折り部分を整理する際に考慮の材料となります。下折り部分では、前の工程でつけた折り筋を基準にして折り進めることをしますから、キーとなる折り筋が山折りになるようにすると、いくぶんながら折りやすくなるのが期待できるわけです。この「犬」というと、工程2で紙の表を上にして折っているのは、5の工程でガイドを見やすくするためです(同時に3も折りやすくなっています)。

ただし、工程2の折り筋は折りたたみの際に山谷が替わってしまいます(41, 78)。後々の工程で山谷をそのまま使えるように折り筋をつけることも、下折り部分の構成における原則ですが、このケースのようにかちあってしまうことも多くて、そういった場合は優先度を検討した上で決めることになります。

It is usually the case that the mountain crease lines are much more visible than the valley ones. This is critical when one does pre-creasing at the beginning of folding procedure. We tend to fold with the pre-creased lines as a reference, so making them mountain (not valley) would make the folding steps easier. In this "Dog", the reason why I fold color side up in Step 2 is for the folder to find the reference in Step 5 (and Step 3, too).

However, the crease line made in Step 2 is folding in the other directions (in Steps 41 and 78). It is of course important to keep the direction of pre-creasing as it will be reassembled later, but in the case in question, doing so would make the folding harder. In such a case, a creator has to decide between the two conflicting features of pre-creasing.