

Wolf

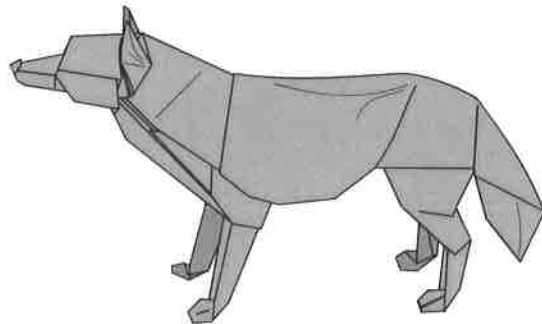

Difficulty: * High Intermediate**
Designed: 2006; Revised: 2013
Recommended starting size: 10" (25 cm)
Finished size: 5" long (13 cm)

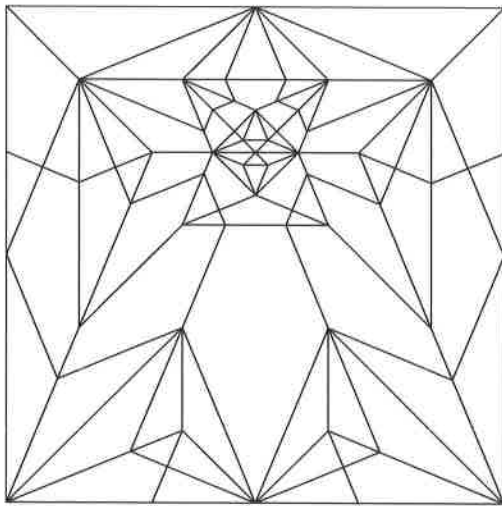
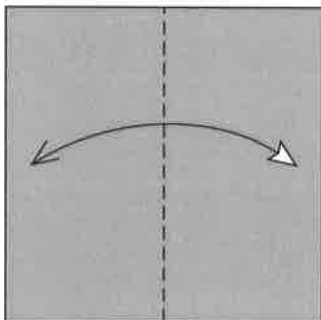

1. Colored side up.
Fold and unfold.

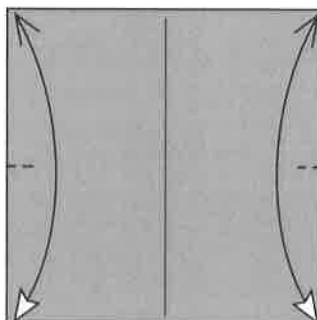

2. Pinch the sides and unfold.

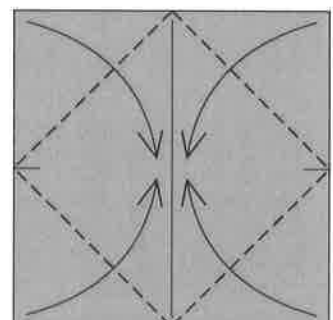

3. Fold the corners to the center.

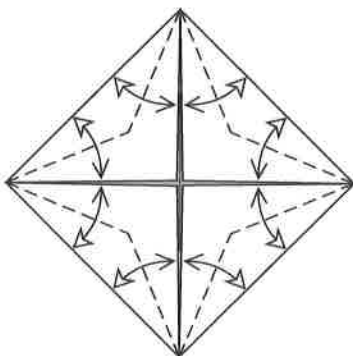

4. Fold along 8 angle bisectors
creasing the top layer only and
unfold.

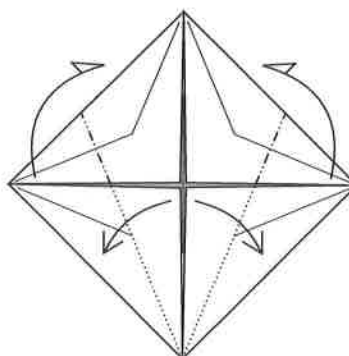

5. Fold behind to the center
line allowing two corners to
swing out to the sides.

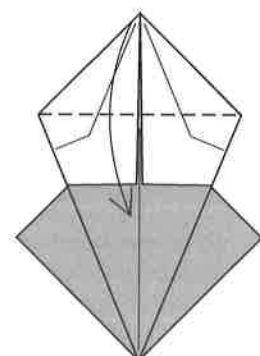

6. Fold down the top corner.

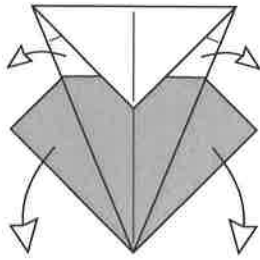

7. Unfold everything except for the top edge.

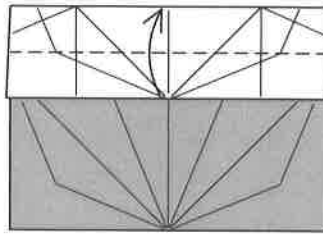

8. Fold to the top.

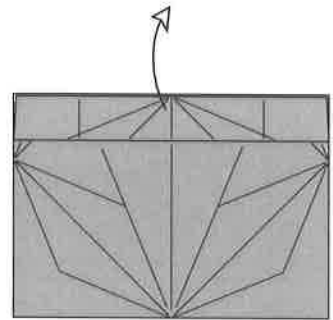

9. Unfold.

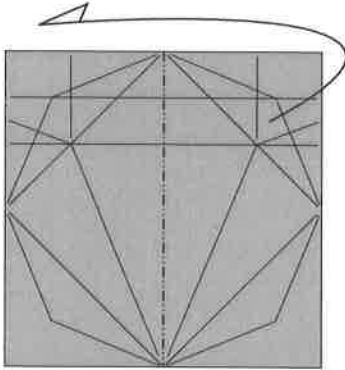

10. Mountain fold in half and rotate 90°.

90°

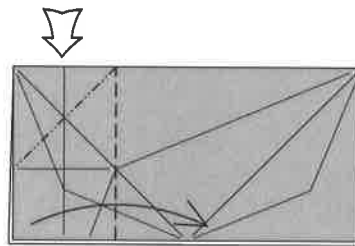

11. Squash fold.

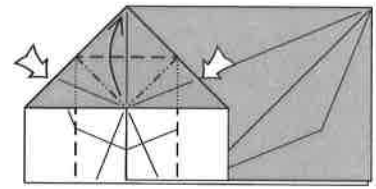

12. Petal-fold.

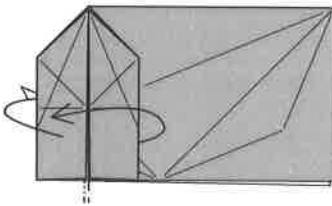

13. Fold one flap behind and the other to the left.

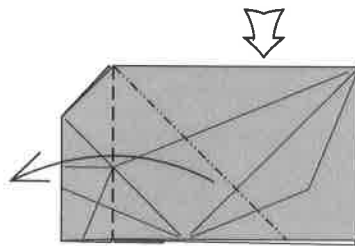

14. Squash-fold.

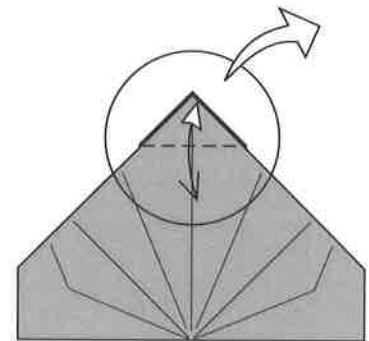

15. Fold and unfold one flap as far as possible then zoom in.

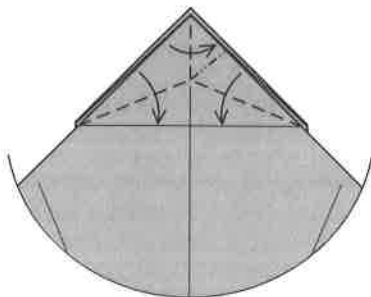

16. Rabbit ear the top flap to the right.

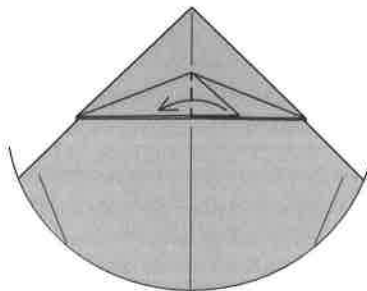

17. Fold the small flap to the left.

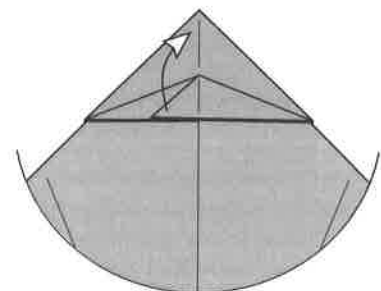

18. Unfold the rabbit ear.

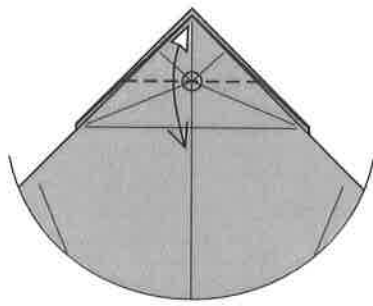

19. Fold and unfold.

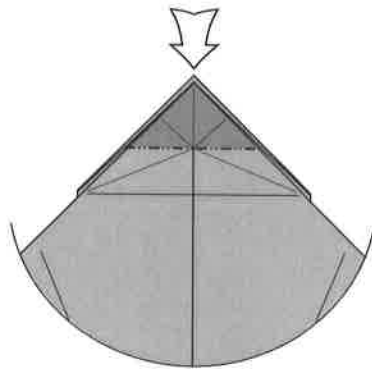

20. Open-sink.

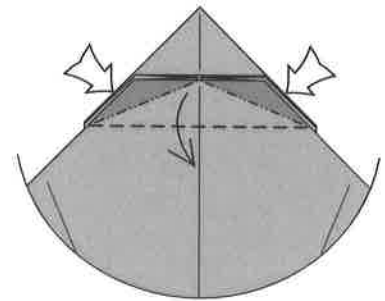

21. Spread-sink two corners.

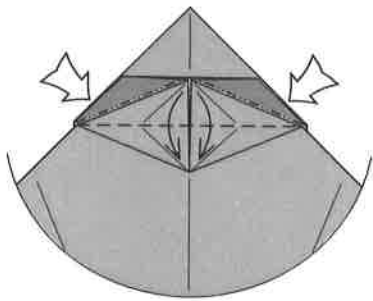

22. Spread-sink two more corners.

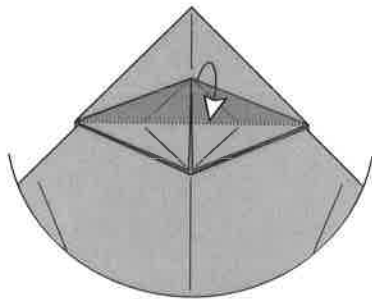

23. Bring one layer in front (closed-sink).

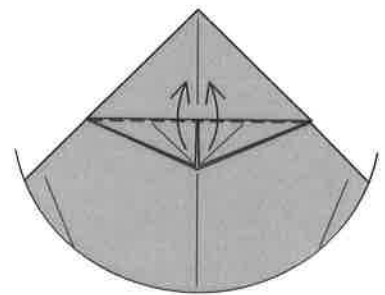

24. Fold the small flaps upward.

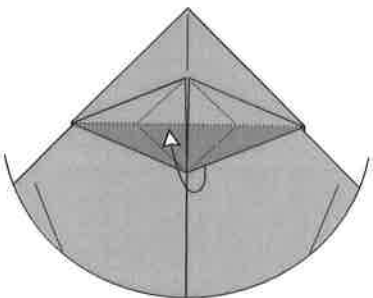

25. Bring one layer in front (Closed-sink).

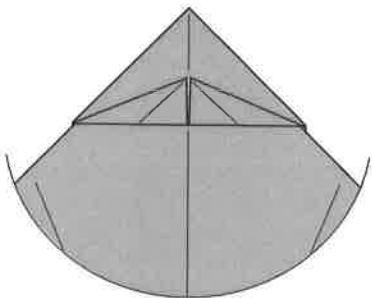

26. Like this. Return to full view.

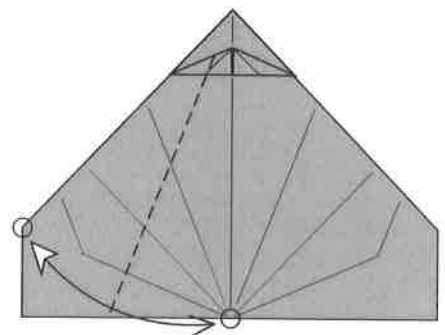

27. Fold and unfold.

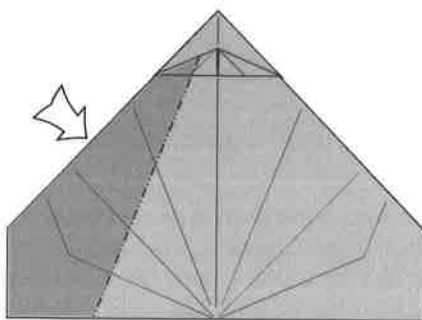

28. Closed-sink.

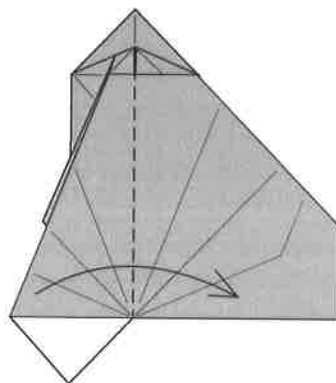

29. Fold one layer over, the top of the model will not lie flat.

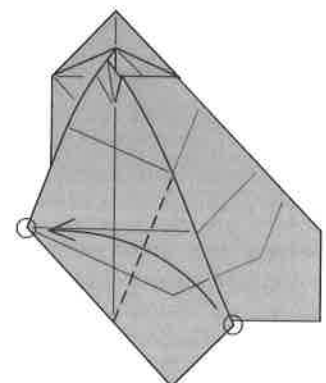

30. Valley-fold.

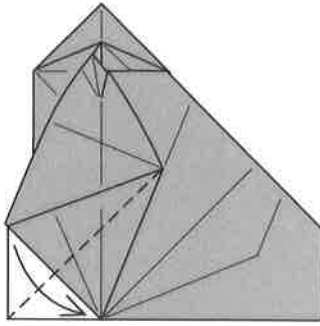

31. Valley-fold.

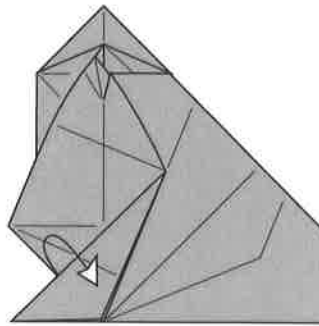

32. Bring one layer in front.

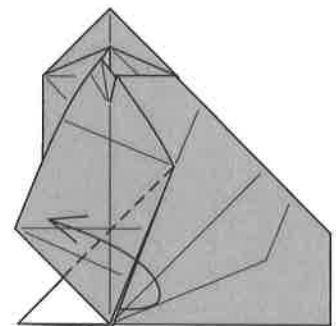

33. Fold two layers over.

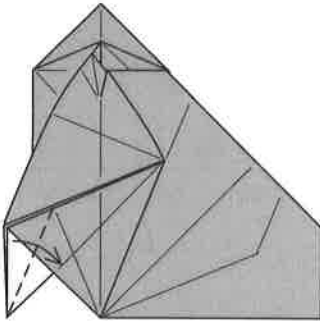

34. Valley-fold.

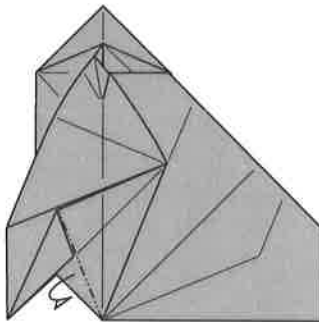

35. Fold behind.

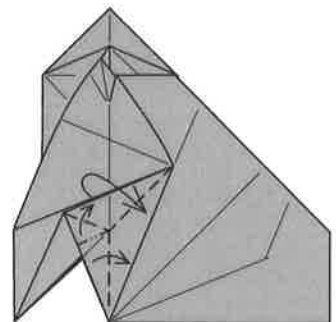

36. Fold two layers back over incorporating a reverse fold as shown.

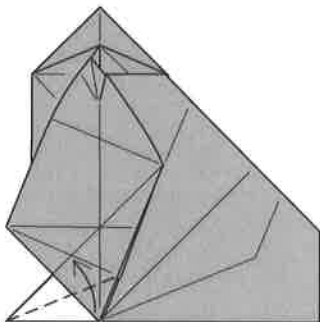

37. Valley-fold.

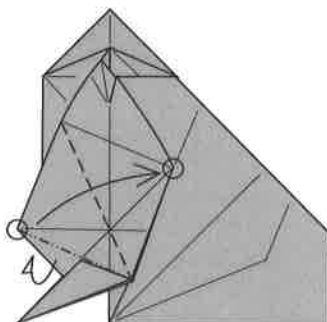

38. Fold the lower edge behind then bring the circled points together.

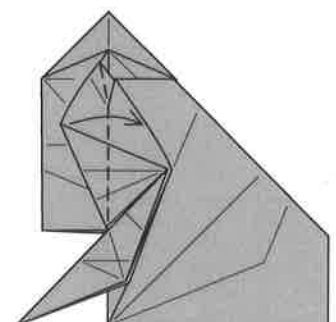

39. Fold one layer over and flatten.

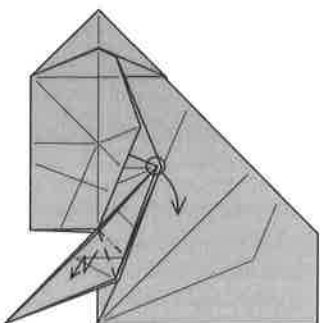

40. Pull out the corner adding a pleat at the base.

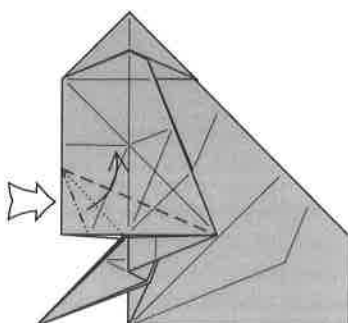

41. Swivel-fold.

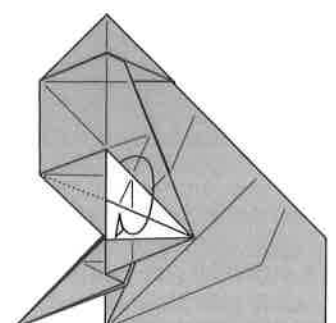

42. Wrap one layer inside.

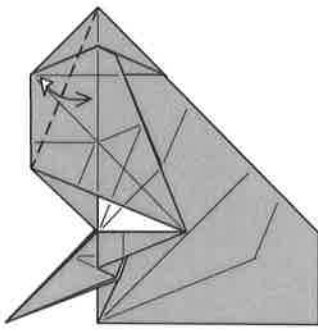

43. Fold and unfold.

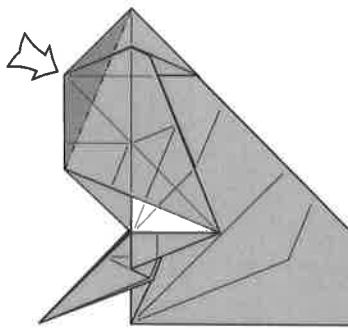

44. Sink inside.

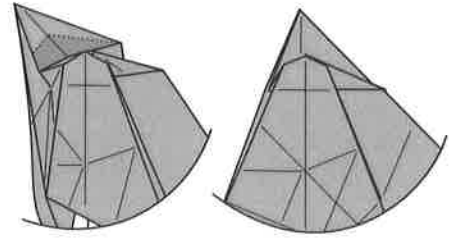

45. The sink is partially open. Note the position of the hidden flap.

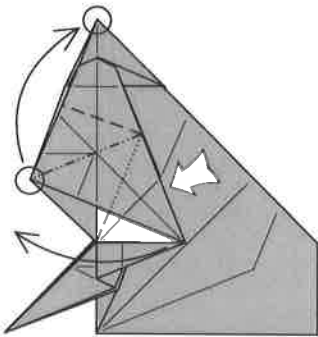

46. Bring the two circled points together and swing the lower corner to the left.

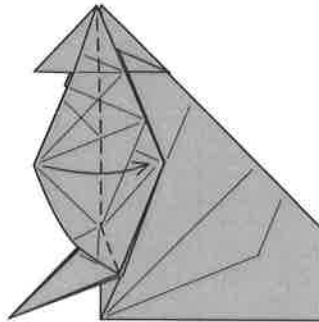

47. Fold over and flatten.

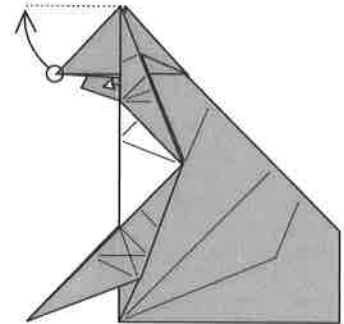

48. Pull the corner out a bit farther.

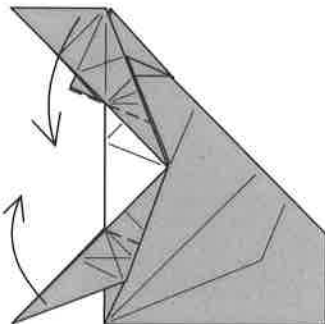

49. Fold the top flap down then the bottom one up.

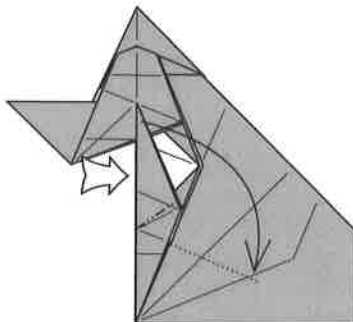

50. Reverse-fold.

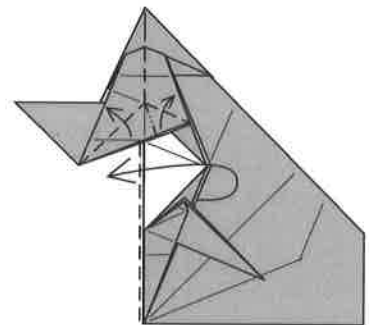

51. Reverse-fold one layer upwards as you fold the short edges back to the left.

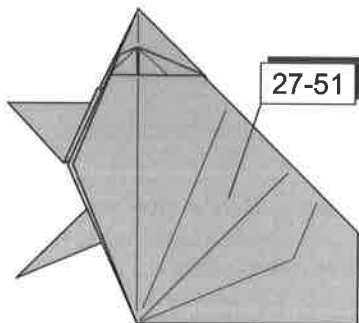

52. Repeat steps 27-51 on the right side.

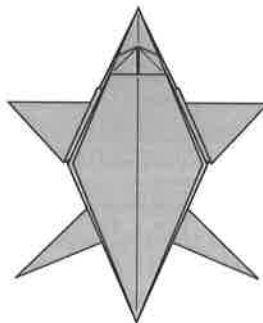

53. Turn over.

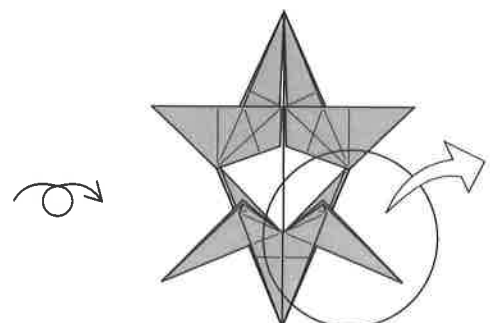

54. Focus on the hind leg.

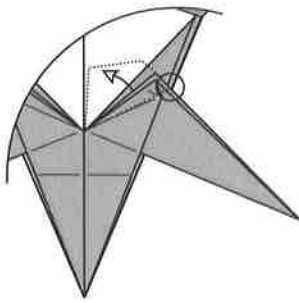

55. Release some paper up to the circled point.

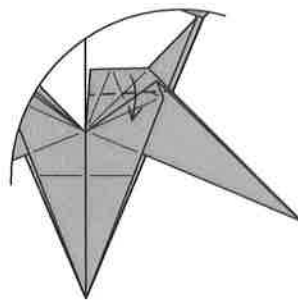

56. Fold the short edge down.

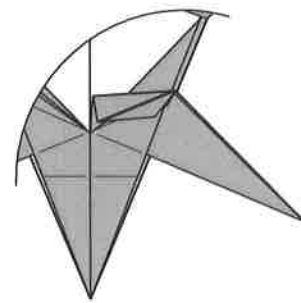

57. Like this, return to full view.

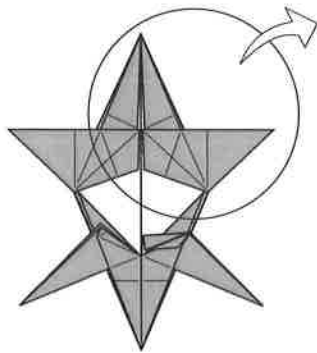

58. Now focus on the foreleg and neck.

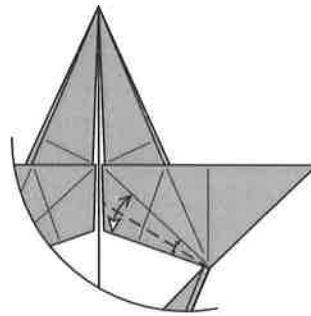

59. Fold and unfold.

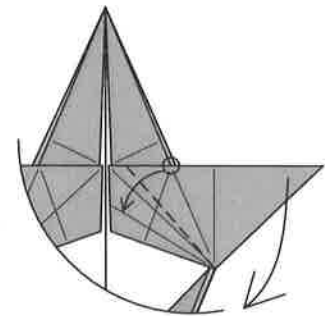

60. Fold the corner down noting the reference.

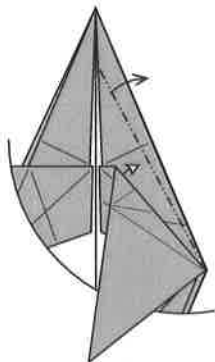

61. Pull out the loose paper.

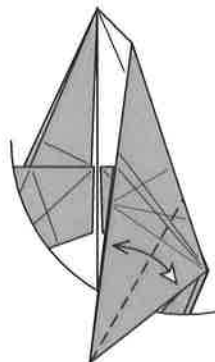

62. Fold and unfold.

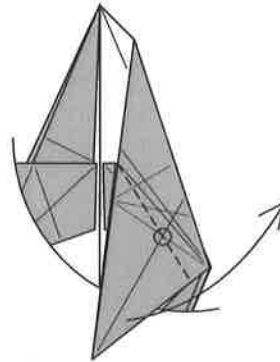

63. Fold back to the side noting the reference.

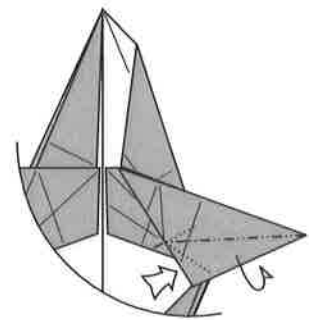

64. Swivel behind.

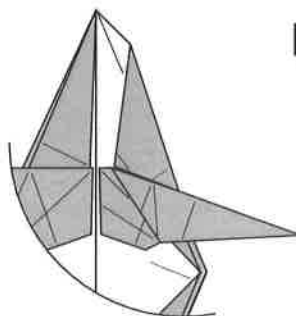

65. Like this. Return to full view.

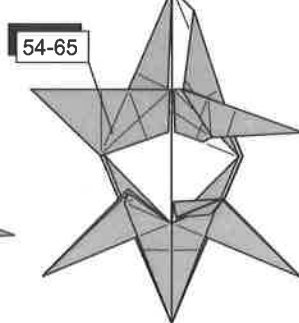

66. Repeat steps 54-65 on th left.

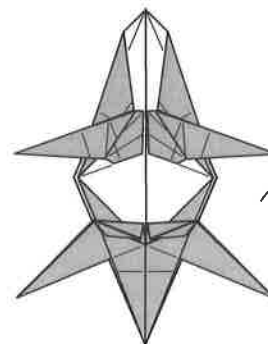

67. Turn over.

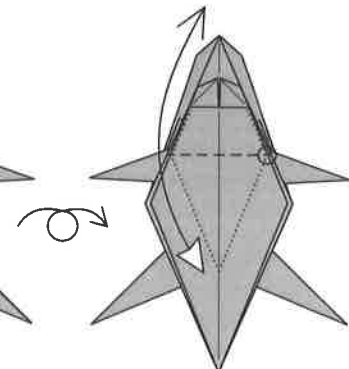

68. Fold and unfold, only creasing through the layers above the forelegs, note the reference.

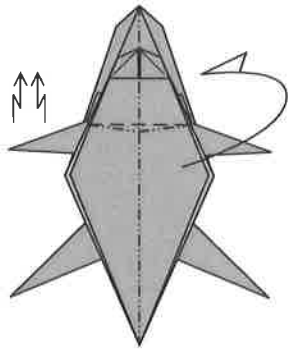

69. Fold in half adding a small crimp along the spine then rotate the model.

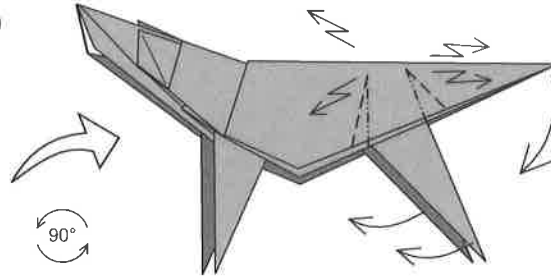

70. Pleat the hips to lower the tail and bring the hind legs closer. Repeat behind.

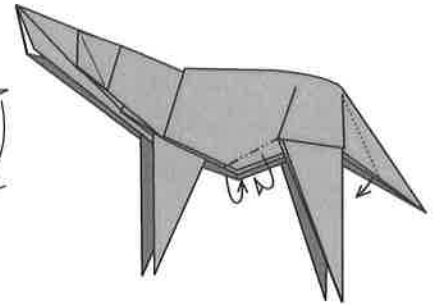

71. Fold the edges in at the belly and pull out some paper at the tail.

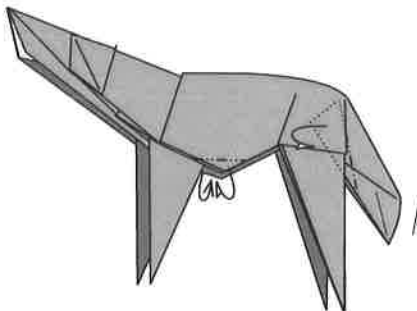

72. Round the belly and shape the tail.

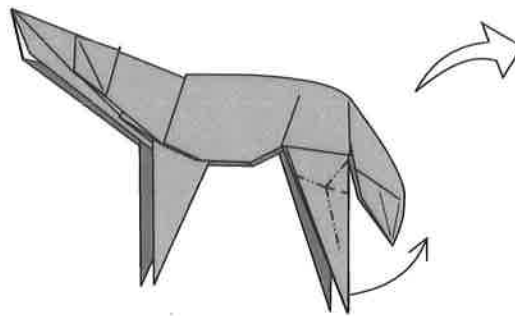

73. Begin to rabbit ear the leg.

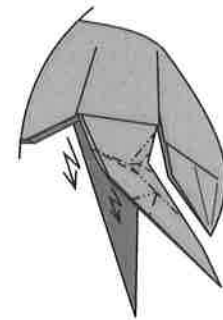

74. Pleat in two places and flatten.

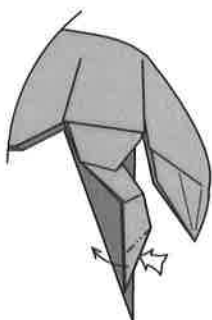

75. Reverse-fold.

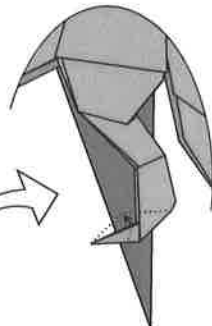

76. Release some paper from behind.



77. Sink the tip of the paw and shape back of the leg.

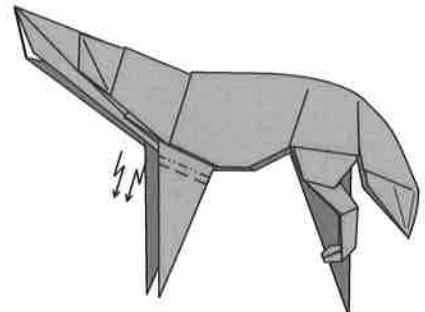

78. Like this, now crimp the foreleg.

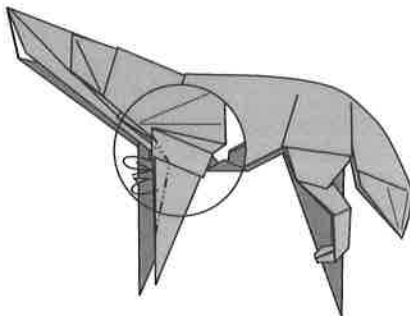

79. Cut away view. Swivel the edges inside.

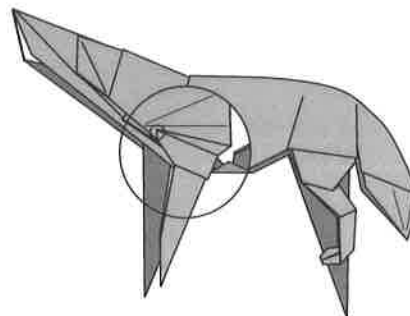

80. This hidden corner is a bit loose. The next series of steps are optional and help lock the corner to the edge behind it.

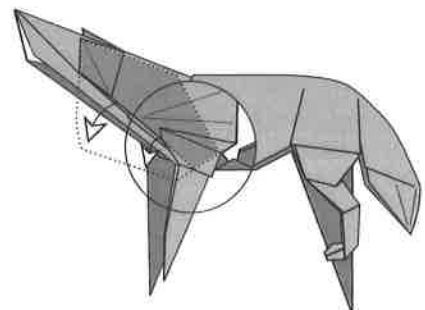

81. Pull out the sunken corner. The paper will not lie flat.

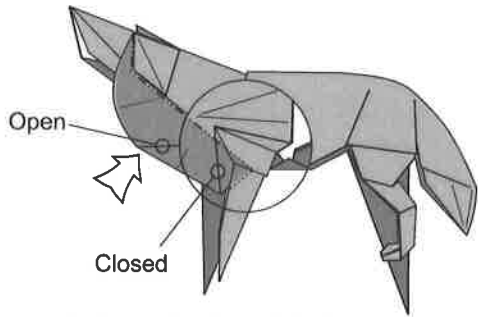

82. Sink back inside to lock. If you prefer you can closed sink the entire region which locks all of the layers together nicely.

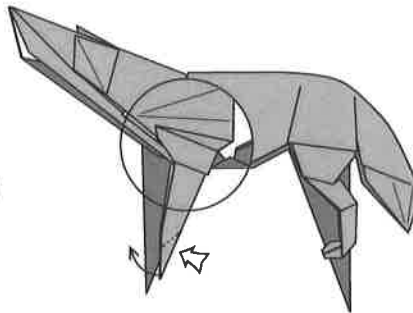

83. Result, now reverse-fold the front paws.

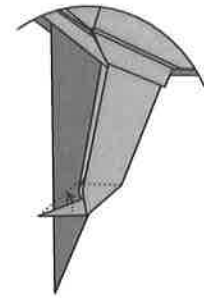

84. Release some paper from behind.

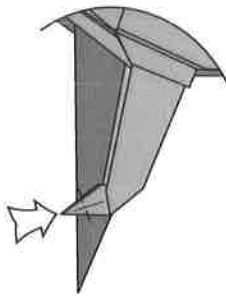

85. Reverse-fold the tip inside.

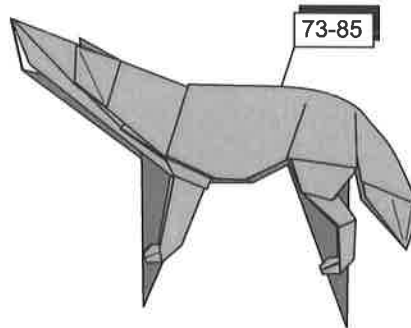

86. Result. Repeat steps 73-85 behind.

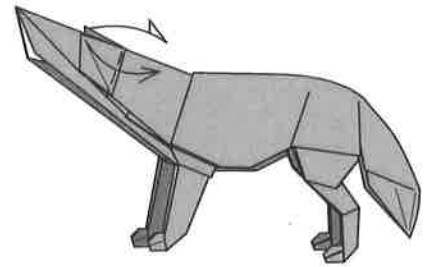

87. Fold the ears back.

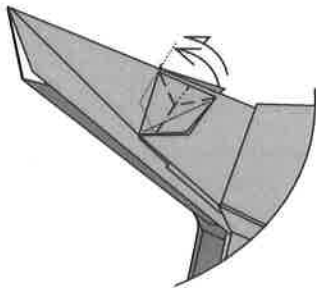

88. Rabbit-ear the ears.

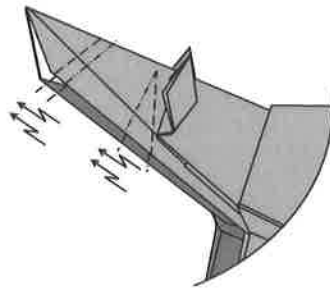

89. Crimp to shape the head.

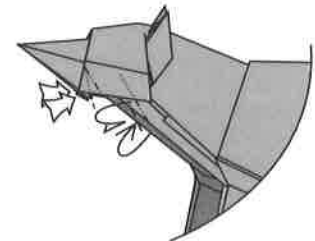

90. Add a couple reverse folds and mountain-folds.

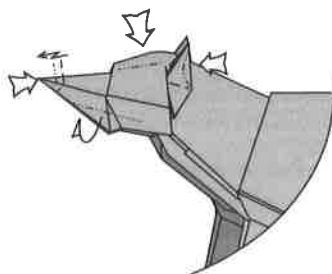

91. Shape the head further.

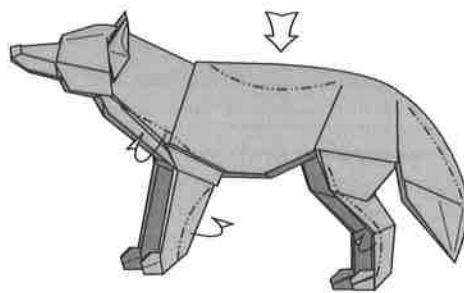

92. Final shaping.

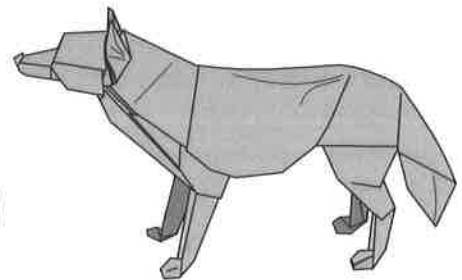

93. Model Complete.