

# The 10th KOREA ORIGAMI CONVENTION Diagrams Collection 2019

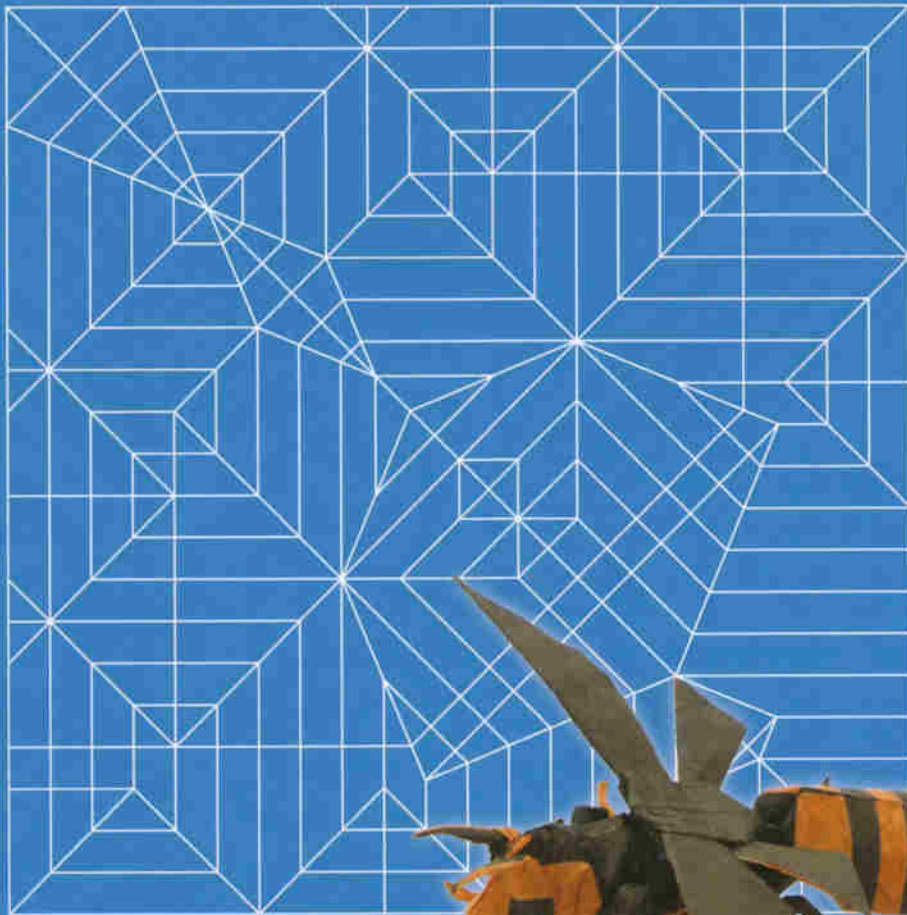

© Hashimoto Haruka



사단법인 한국종이접기협회  
KOREA ORIGAMI ASSOCIATION

**Table of Contents**

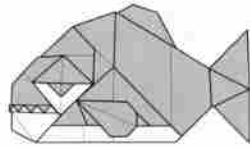

- 무스 (Moose) 06~24
- 옷을 입은 토끼 (Dressed rabbit) 25~33
- 호랑나비 (Swallowtail) 34~36
- 토끼 (Rabbit) 37~39
- 작은 여우 (Little Fox) 40~43
- 고양이 (Cat) 44~48
- 말벌 (Wasp) 49~61
- 피라냐 (Piranha) 62~70
- 공작 (Peacock) 71~73
- 돼지 머리 (Piggy's Head) 74~77
- 페넥여우 (Fennec Fox) 78~79
- 페가수스 1.0 (Pegasus 1.0) 80~83
- 사슴 헌팅 트로피 (Deer Hunting Trophy) 84~87
- 흡혈 박쥐 (Vampire Bat) 88~96



- 학사모 (Graduation Cap) 97
- 카네이션 (Carnation) 98~101
- Gear Cube 102~103
- Erizo purpura purple sea urchin 104~112
- Sundrop Flower 113~115
- 별(蘭) 유닛 1.2.3.4 (star(orchid) unit 1.2.3.4) 116~119
- Rotari Star 120~121
- 은하계 (Galaxia) 122
- Umbrella Ball 123~125
- Ball pop up card 126~131
- 꽃병 (Vase) 132~133
- 전등갓 (Lampshade) 134~138

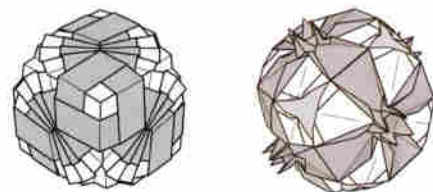
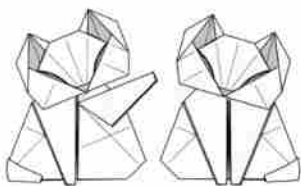

# 접기 기본 기호

★다음 기호에 의하여 접는 방법이 표시되므로 기본 기호와 약속을 꼭 기억하세요.

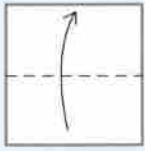

끝자리접기

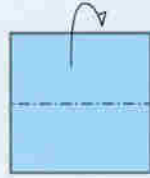

산접기



접었다 편 선 만들기



화살표 방향으로 접기

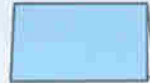

뒤로 접기



같은 방향으로 계속 접기



자르기

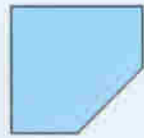

가상선 (또는 숨은 선)  
접기 전의 선



확대

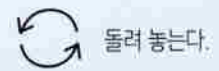

돌려 놓는다.



축소



부들린다.



계단접기



안쪽으로  
접기

밖으로 뒤집어 접기

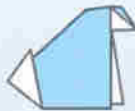

펼친다.



밀어 넣는다.



화살표 방향으로  
끼우거나 잡아 뻐다.



◆삼각접기 기본형

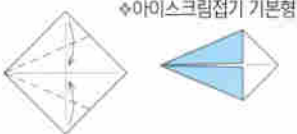

◆아이스크림접기 기본형

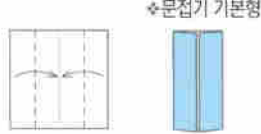

◆문접기 기본형



◆방석접기 기본형

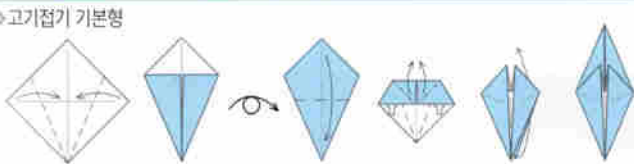

◆고기접기 기본형

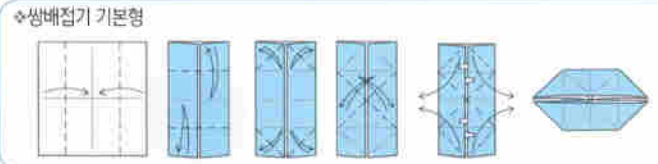

◆쌍배접기 기본형

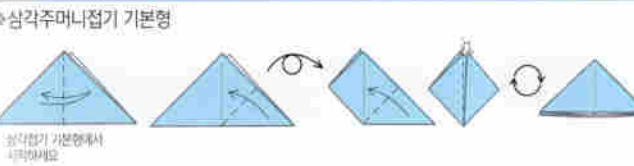

삼각접기 기본형에서 시작하세요

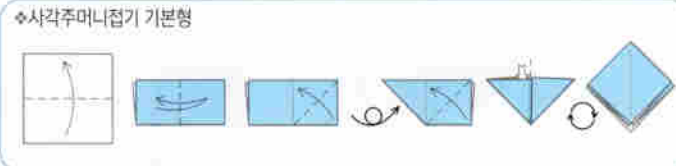

◆사각주머니접기 기본형

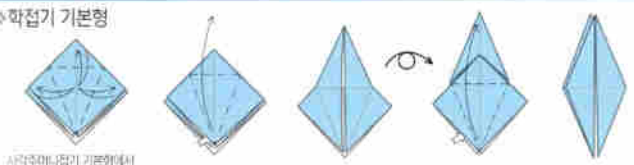

◆학접기 기본형

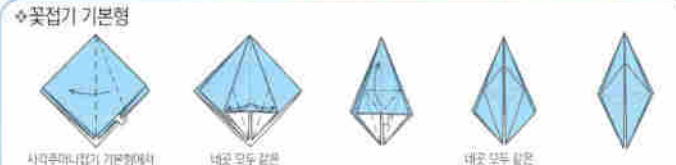

◆꽃접기 기본형

사각주머니접기 기본형에서 시작하세요

사각주머니접기 기본형에서 시작하세요

네곳 모두 같은 방법으로 접으세요

대각 모두 같은 방법으로 접으세요



무스 Moose



옷을 입은 토끼  
Dressed rabbit



호랑나비 Swallowtail



작은 여우 Little Fox



토끼 Rabbit



말벌 Wasp



흡혈 박쥐 Vampire Bat



고양이 Cat



공작 Peacock



피라냐 Piranha



페가수스1.0 Pegasus1.0



돼지 머리 Piggy's Head



페넥여우 Fennec Fox



사슴 헌팅 트로피  
Deer Hunting Trophy



Rotari Star



은하계 Galaxia



Umbrella Ball



Ball pop up card



Gear Cube



꽃병 Vase



전등갓 Lampshade

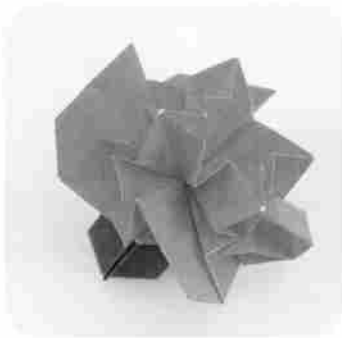

카네이션 Carnation



Sundrop Flower



별(蘭) 유닛 1.2.3.4  
star(orchid) unit 1.2.3.4



Erizo purpura purple  
sea urchin



학사모 Graduation Cap

# 무스 Moose

by Quentin Trollip : Canada

Diagram by Quentin Trollip

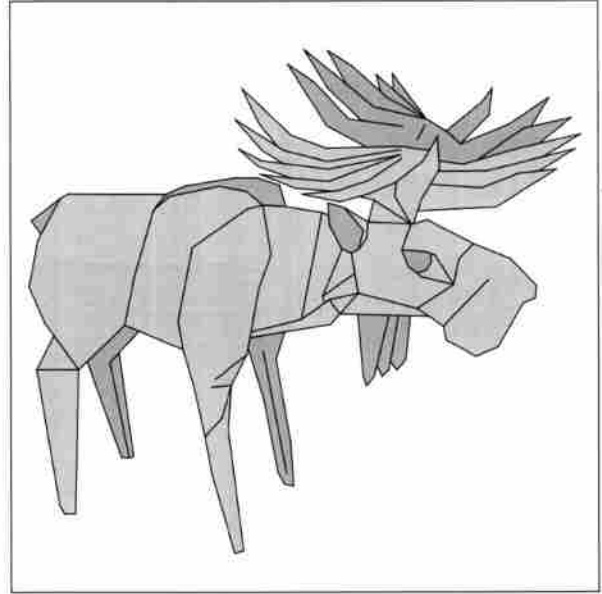
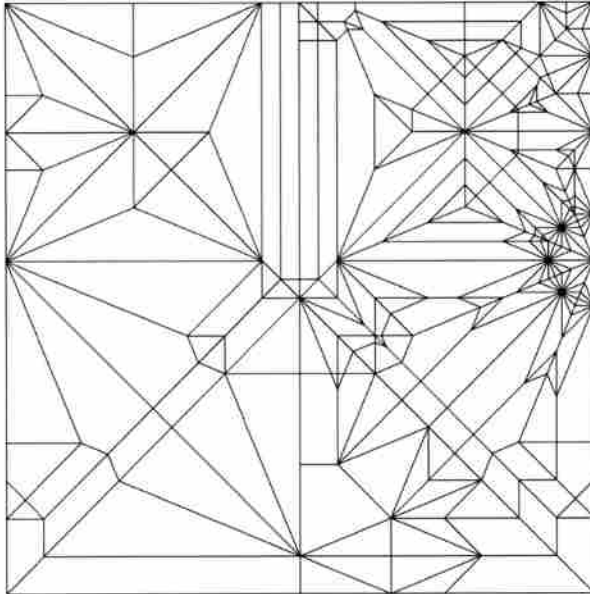

Date created: 20 January 2017

Recommended size and ratio: 40 cm = 12 cm high

Beware, this is an extremely complex design. You will have to be a very experienced folder to be able to fold this moose.

A good result will also depend on the correct paper choice, as well as doing a test-fold to understand the folding sequence and design.

I suggest using the thinnest and strongest paper possible in a size no less than 70 cm (2-2,5 ft) per side. I also suggest treating the paper with sizing (like methylcellulose) before folding. This will add stiffness to the paper and make the creases crisper.

The model is also very front-heavy, and will require support in the front legs to hold up its weight. I suggest hiding wire supports between the layers of the front legs.

You will need to use some intuition to shape the model at the end (step 190 onwards). The shaping here depends greatly on the thickness of the paper you use.

Steps 72 to 138 shows the thinning of the points of the one side of the model. When performing all these steps on only one side, it may be difficult to repeat them on the other side. You may want to do all these steps symmetrically. It just made sense to diagram all the folds on one side of the model.

Try to hide the thick layers of the base of the antlers with the flaps of the ears. Crimp-fold the neck in a way to make a shoulder hump.

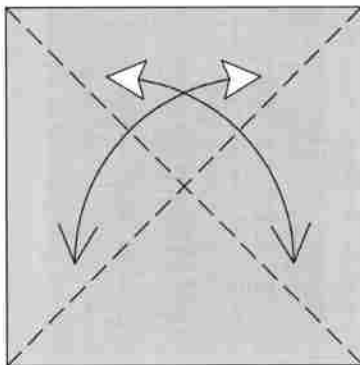

1 Pre-crease.

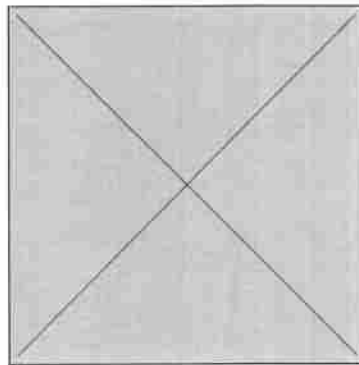

2 Turn over.

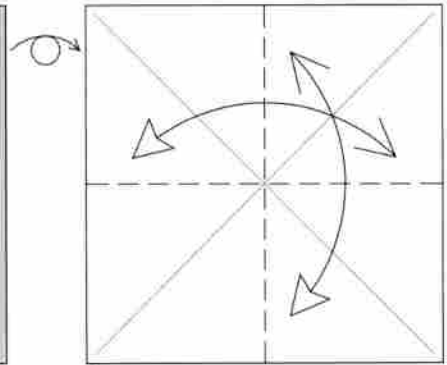

3 Pre-crease.

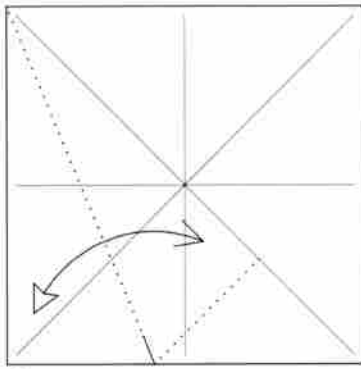

4 Pinch.

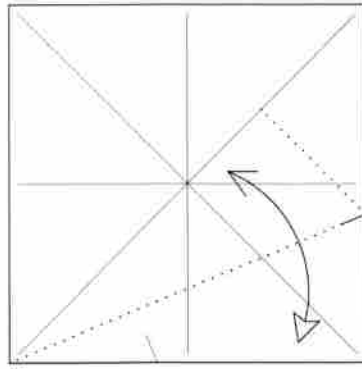

5 Pinch.

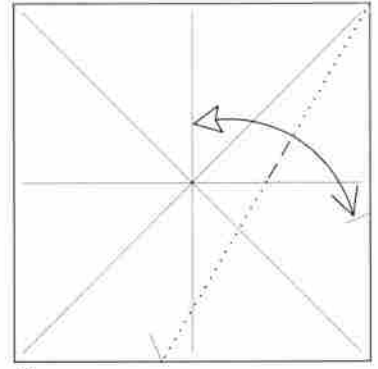

6 Pinch.

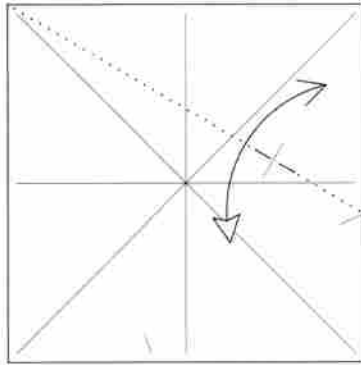

7 Pinch.

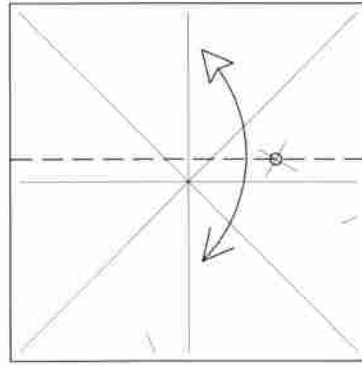

8 Pre-crease.

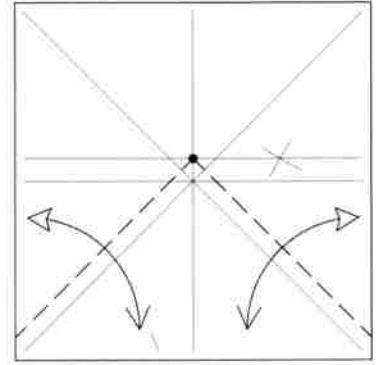

9 Pre-crease.

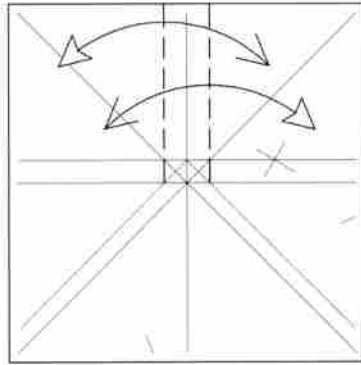

10 Pre-crease.

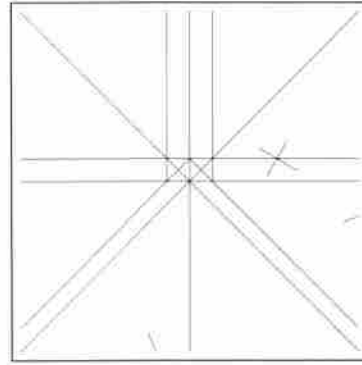

11 Turn over.

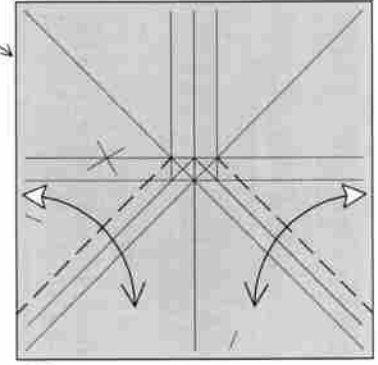

12 Pre-crease.

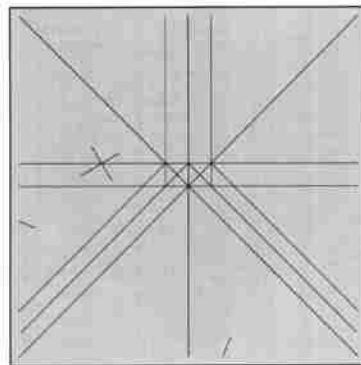

13 Turn over.

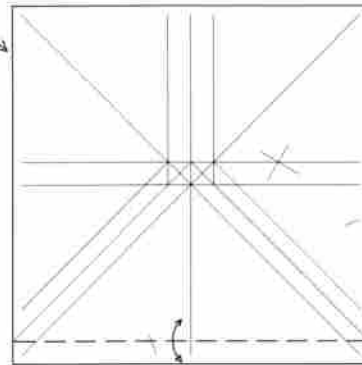

14 Pre-crease.

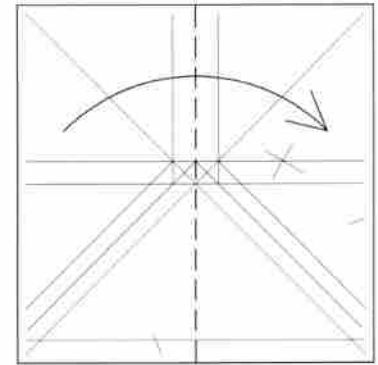

15 Valley fold.

16

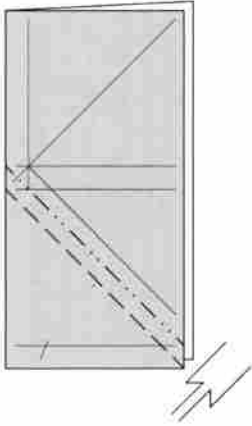

Crimp fold.

17

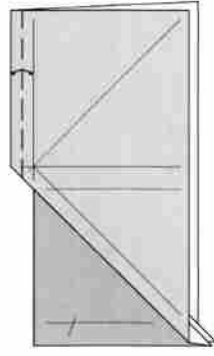

Valley fold and unfold.

18

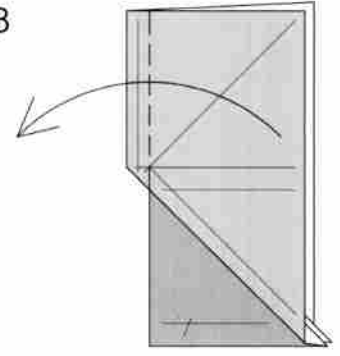

Valley fold.

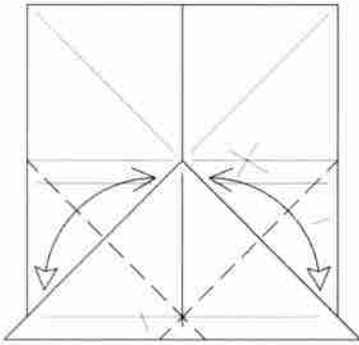

19 Pre-crease.

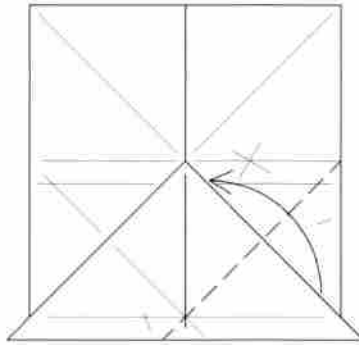

20 Valley fold.

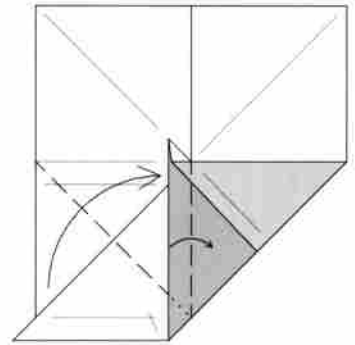

21 Swivel fold.

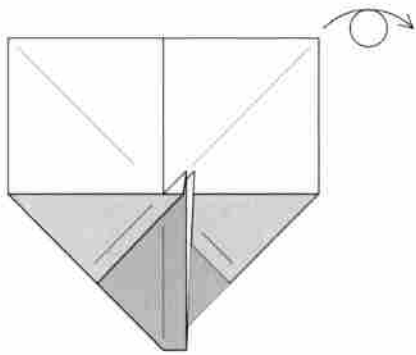

22 Turn over.

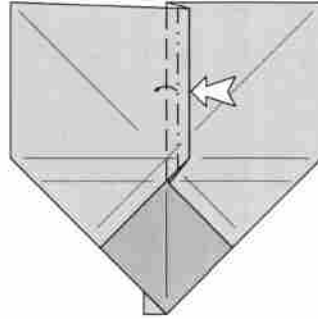

23 Spread squash.

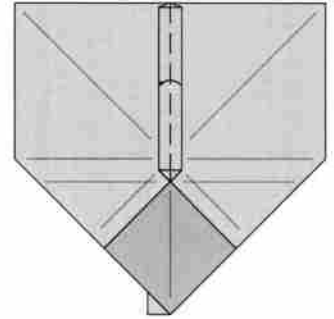

24 Valley fold.

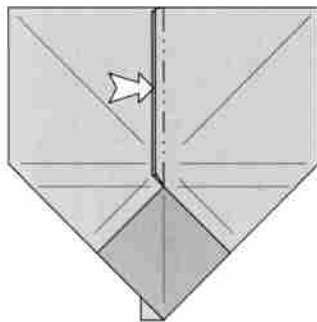

25 Closed-sink.

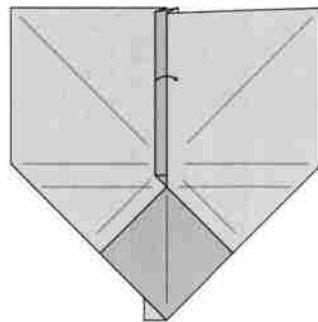

26 Repeat steps 24 to 25 on the left.

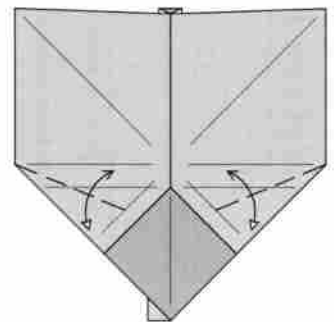

27 Pre-crease through the top layer.



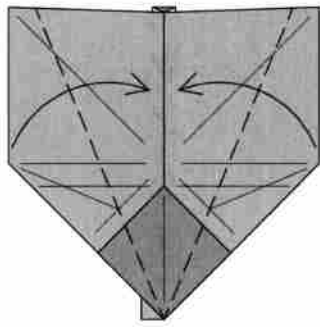

28 Valley folds.

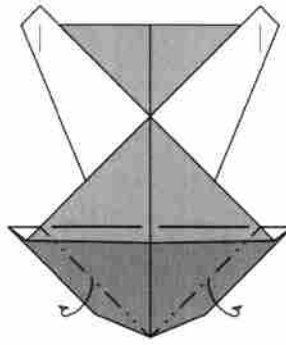

29 Mountain folds.

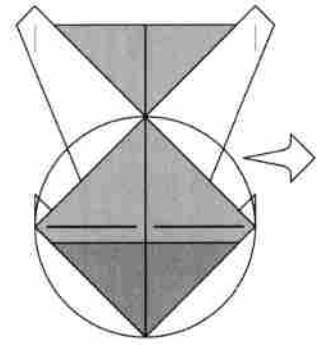

30 Enlarge.

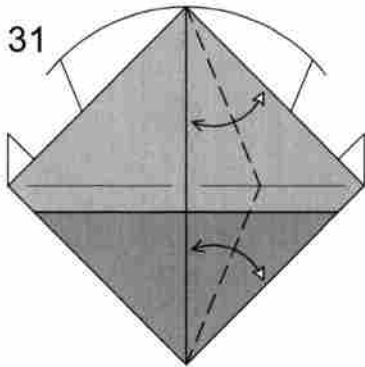

Pre-crease.

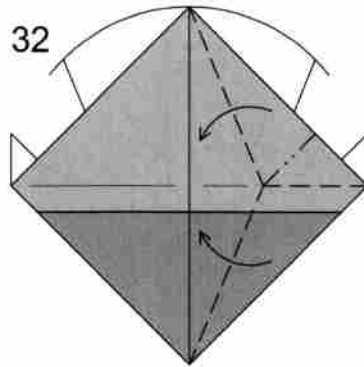

Rabbit-ear.

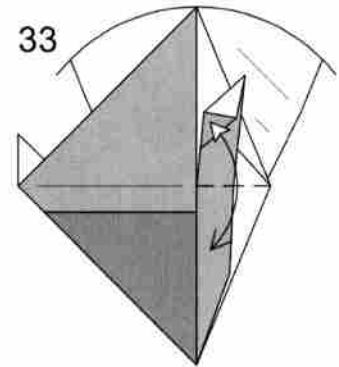

Valley fold and unfold.

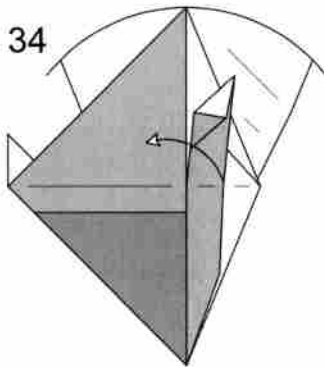

Unfold the raw edge.

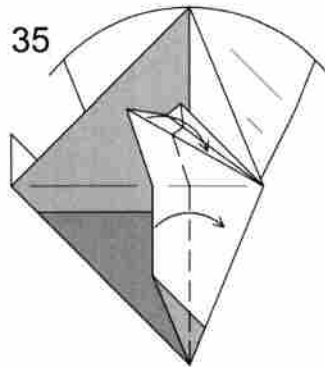

Valley fold through the whole length.

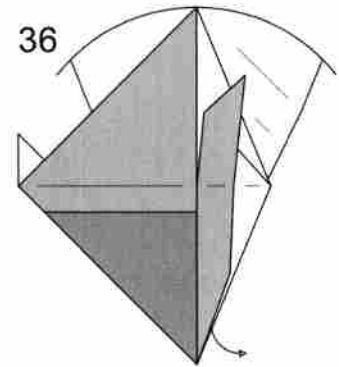

Pull out the raw edge.

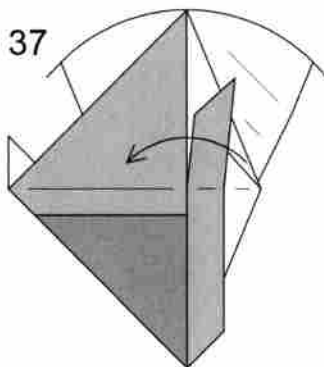

Valley fold.

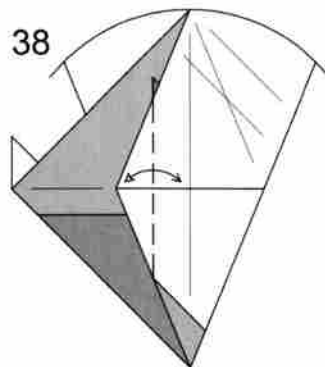

Valley fold and unfold.

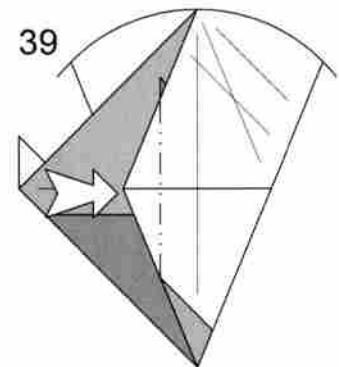

Open sink.

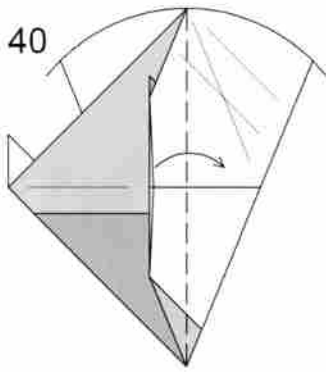

40 Valley fold.

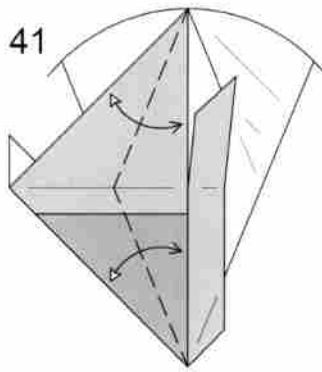

41 Repeat steps 31 to 40 on the left.

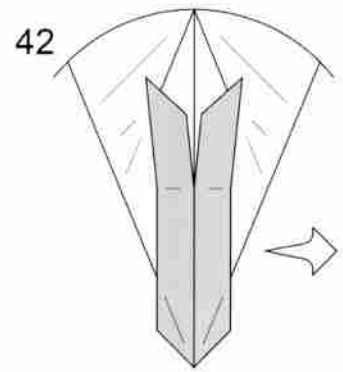

42 Scale change.

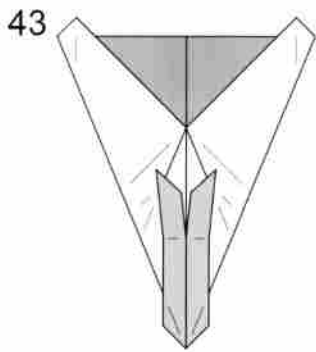

43 Turn over.

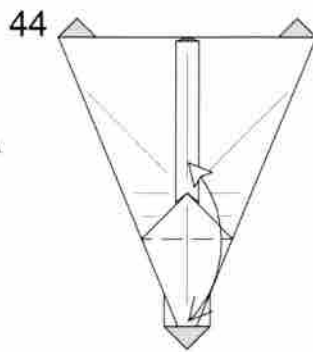

44 Valley fold and unfold.

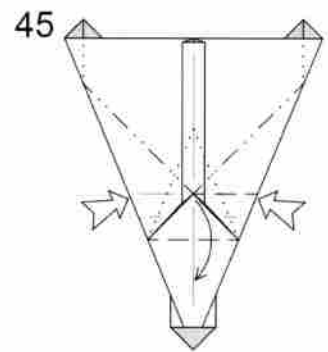

45 Collapse on existing creases.

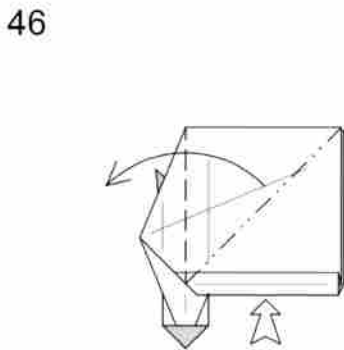

46 Squash fold.

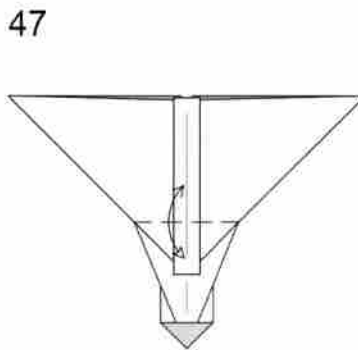

47 Valley fold and unfold.

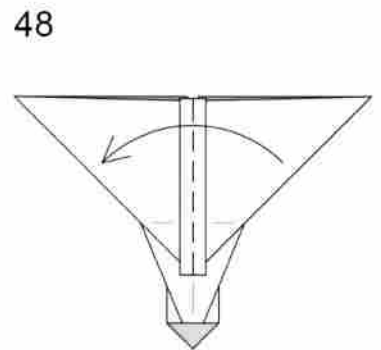

48 Valley fold.

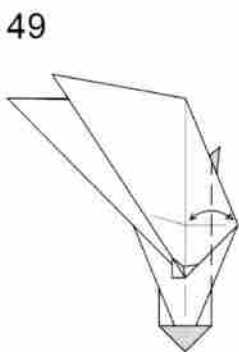

49 Valley fold and unfold.

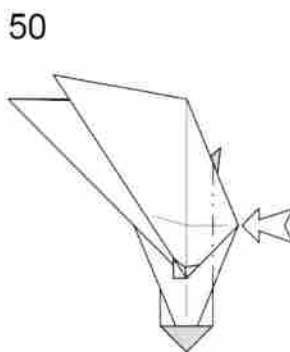

50 Open sink.

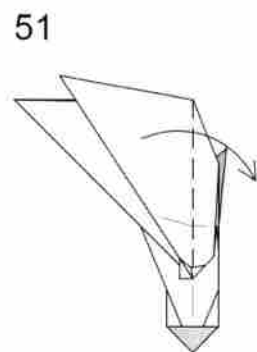

51 Flatten.

52

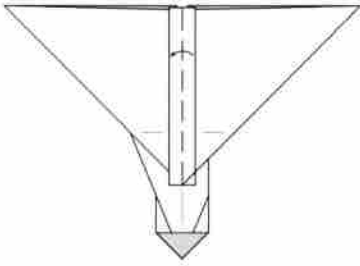

Valley fold.

53

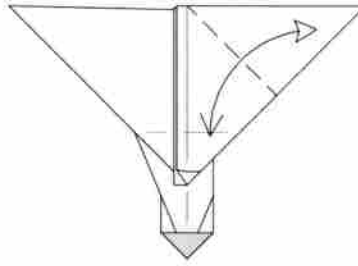

Valley fold and unfold.

54

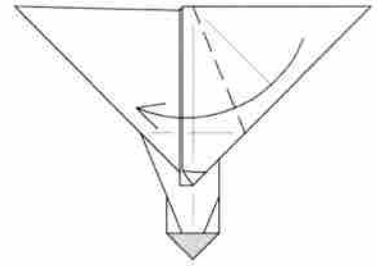

Valley fold.

55

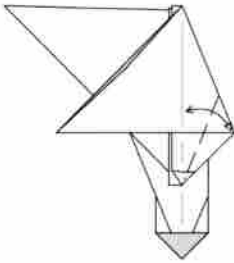

Valley fold and unfold.

56

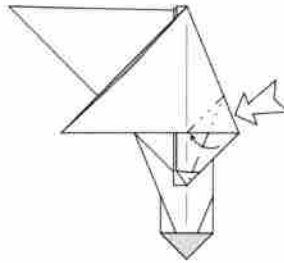

Swivel fold.

57

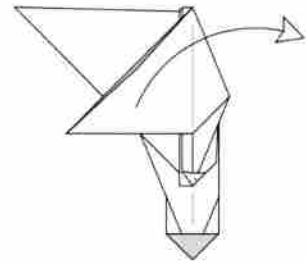

Unfold.

58

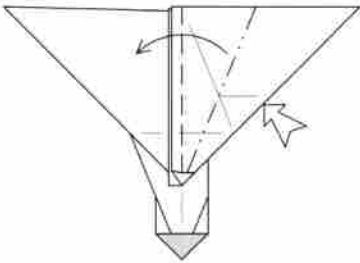

Squash fold.

59

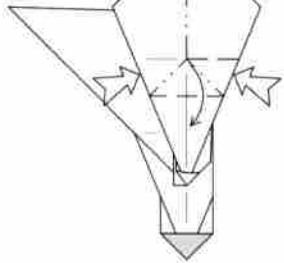

Collapse on existing creases.

60

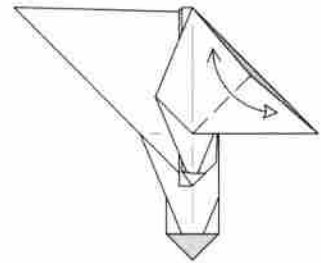

Valley fold and unfold.

61

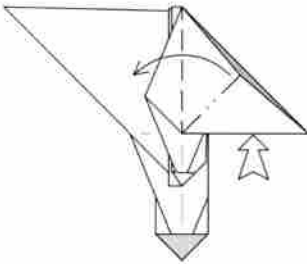

Squash fold.

62

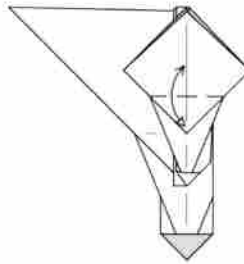

Valley fold and unfold.

63

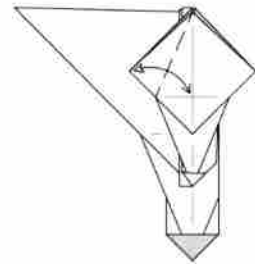

Valley fold and unfold.

64

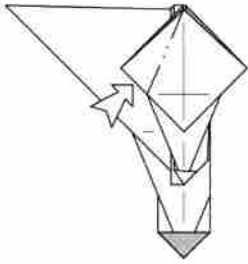

Inside reverse-fold.

65

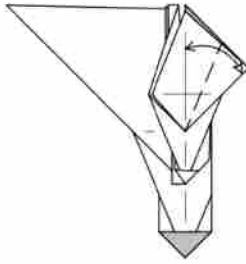

Valley fold and unfold.

66

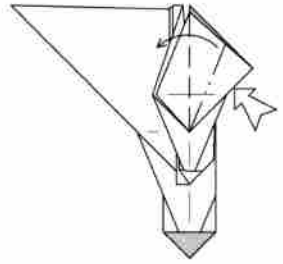

Squash fold.

67

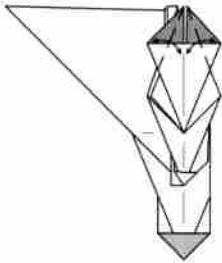

Pre-crease.

68

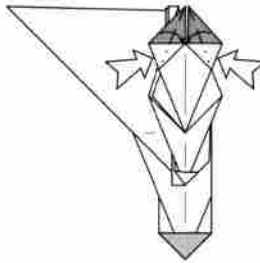

Swivel-fold inside.

69

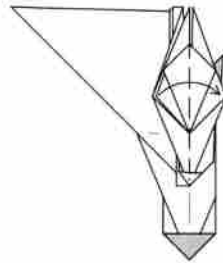

Valley fold.

70

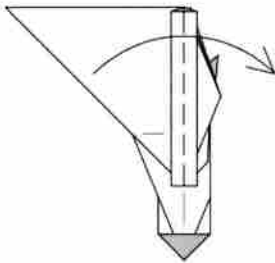

Repeat steps 48 to 69 on the left.

71

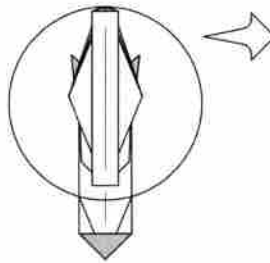

Enlarge.

72

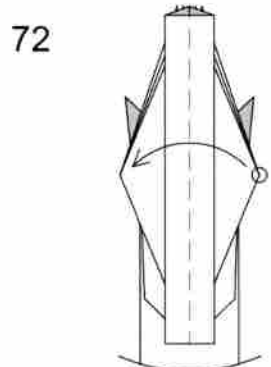

Valley fold three points.

73

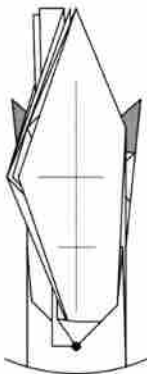

Unsink the tip.

74

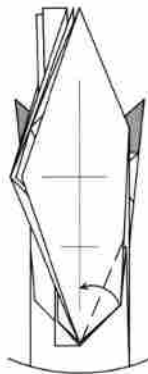

Valley fold.

75

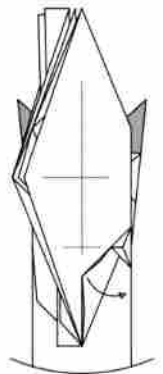

Unfold.

76

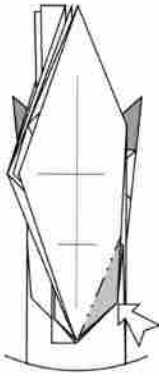

Open sink only indicated layer.

77

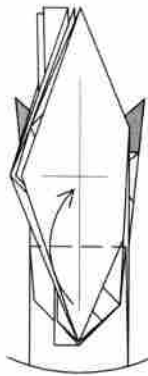

Valley fold up.

78

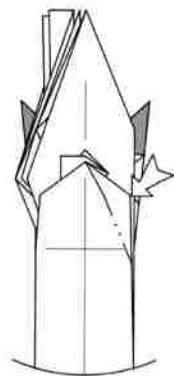

Closed sink.

79

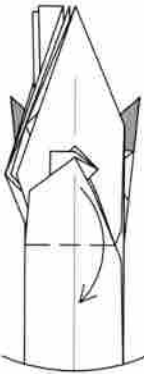

Valley fold.

80

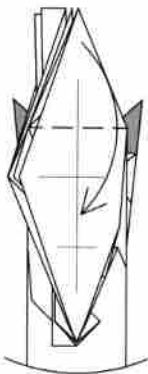

Valley fold.

81

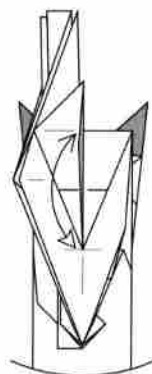

Valley fold and unfold.

82

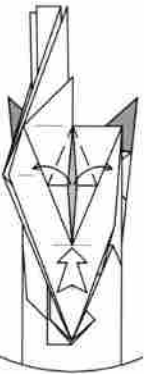

Open sink and then spread the layers.

83

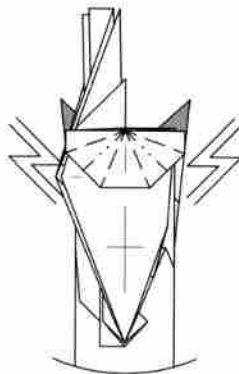

The result. Pleat-folds.

84

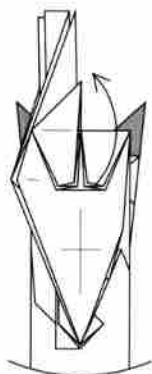

Valley fold up.

85

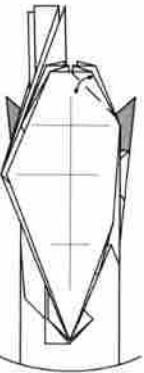

Valley fold and unfold.

86

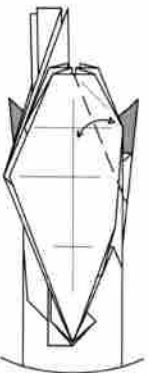

Valley fold and unfold.

87



Sink in and out.

88

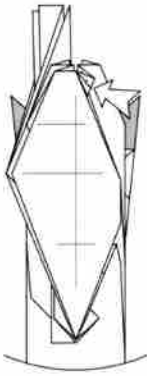

Reverse-fold in and out.

89

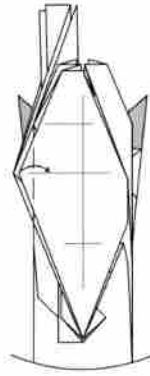

Valley fold.

90

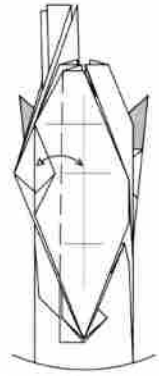

Valley fold and unfold.

91

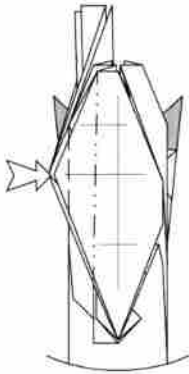

Open sink in and out.

92

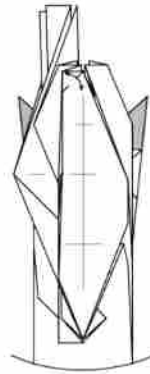

Valley fold and unfold.

93

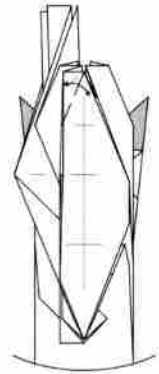

Valley fold and unfold.

94

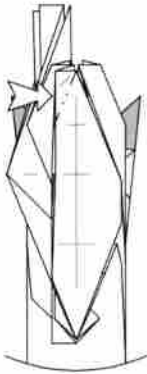

Reverse-fold in and out.

95

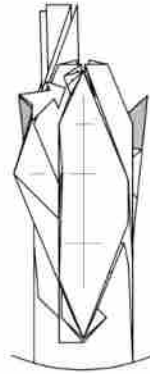

Reverse-fold in and out.

96

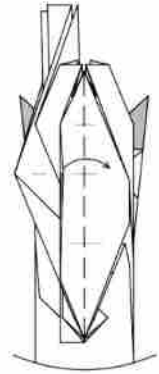

Valley fold.

97

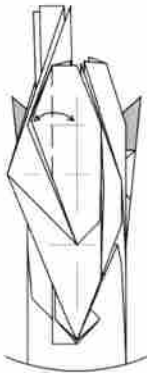

Valley fold and unfold.

98

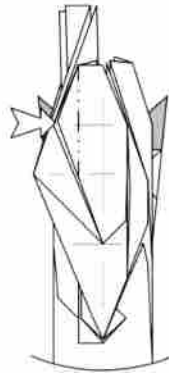

Open sink.

99

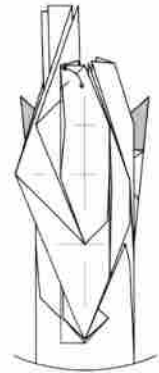

Repeat steps 92 to 95.

100

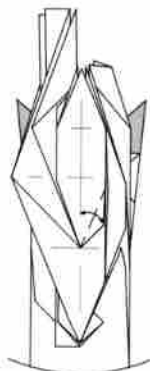

Valley fold and unfold.

101

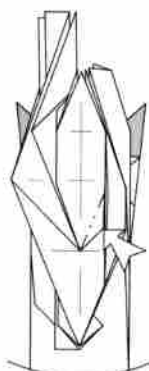

Spread sink.

102

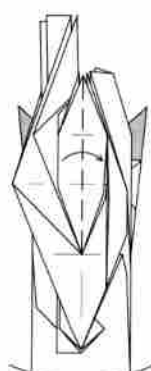

Valley fold.

103

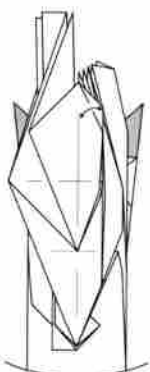

Valley fold and unfold.

104

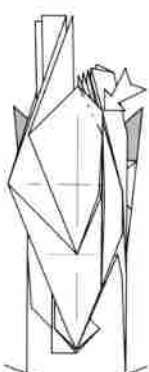

Spread sink.

105

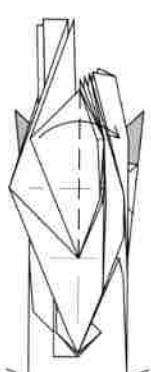

Valley fold.

106

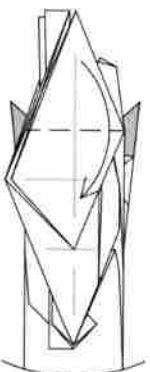

Valley fold.

107

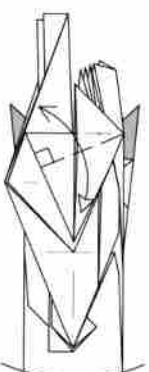

Valley fold and unfold.

108

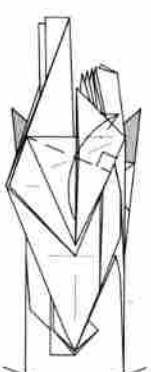

Valley fold.

109

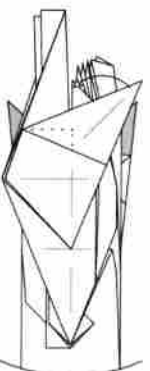

Pull out the raw edge.

110

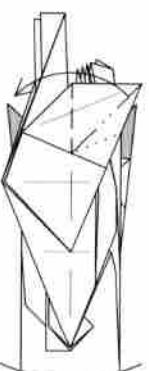

Swivel fold.

111

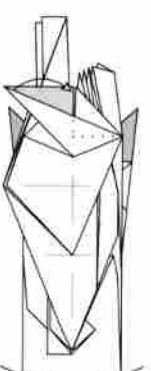

Pull out the raw edge.

112



Valley fold and unfold.

113

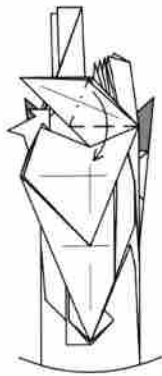

Swivel fold.

114



Valley fold.

115

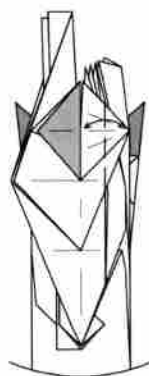

Valley fold and unfold.

116

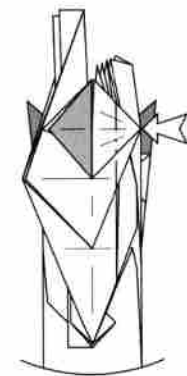

Open sink.

117

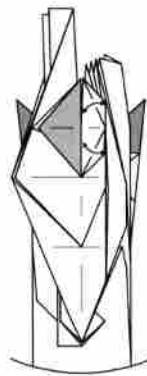

Valley folds and unfold.

118



Open sinks.

119

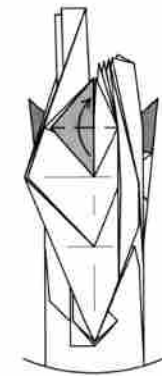

Valley fold.

120

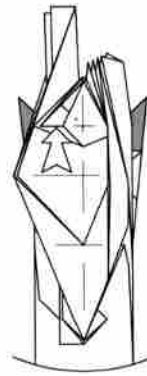

Inside reverse-fold.

121



Inside reverse-fold both points.

122

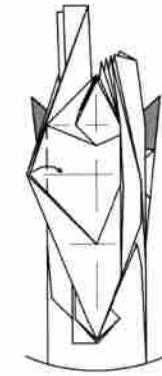

Valley fold.

123

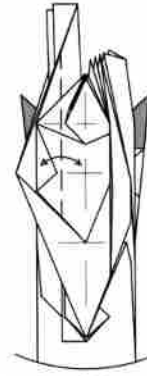

Valley fold and unfold.



124

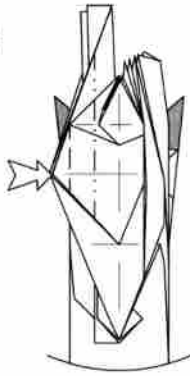

Open sink in and out.

125

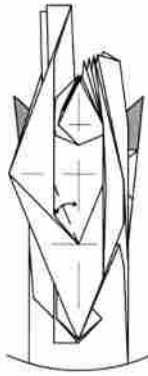

Valley fold and unfold.

126

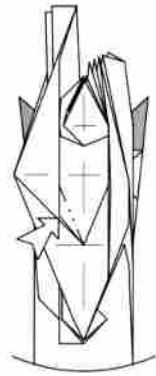

Spread sink.

127

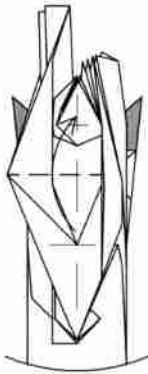

Valley fold.

128

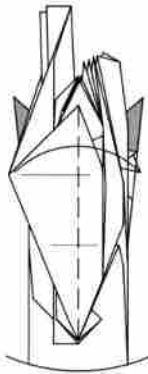

Valley fold.

129

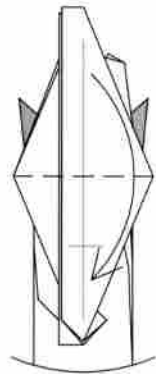

Valley fold.

130



Valley fold and unfold.

131

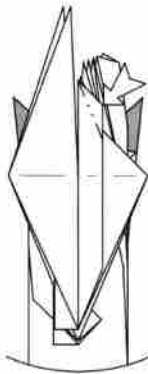

Spread sink.

132

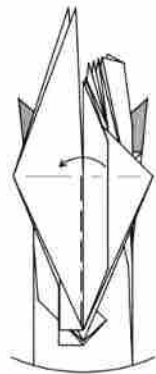

Valley fold.

133

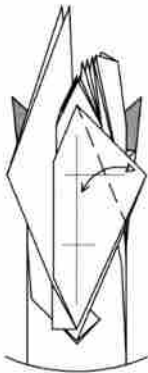

Valley fold and unfold.

134

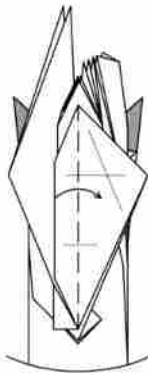

Valley fold.

135

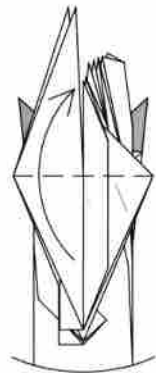

Valley fold.

136

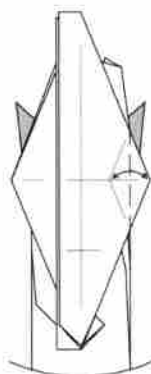

Valley fold and unfold.

137

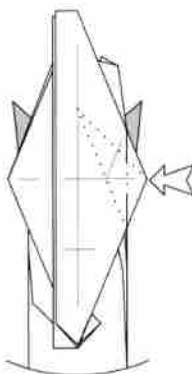

Open sink on crease made in step 133.

138

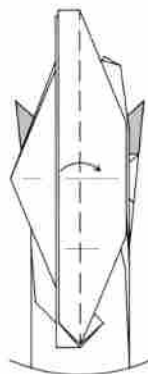

Valley fold.

139

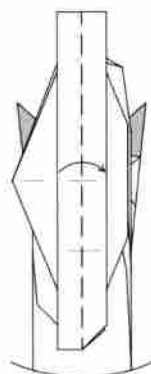

Repeat steps 72 to 138 on the left.

140

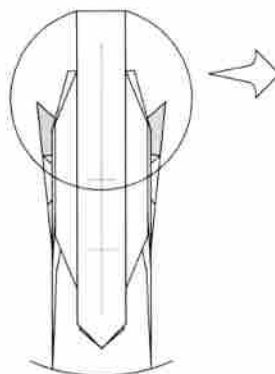

Enlarge.

141

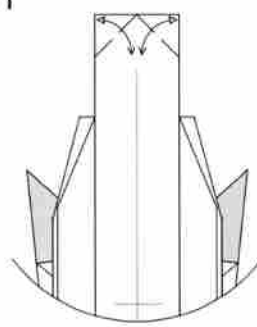

Valley folds and unfold.

142

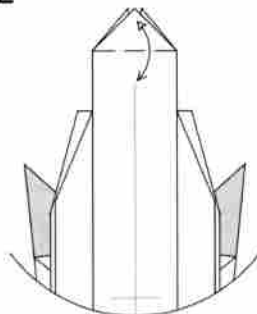

Valley fold and unfold.

143

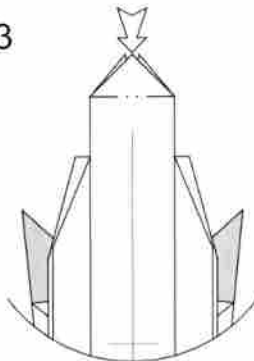

Inside reverse-fold.

144

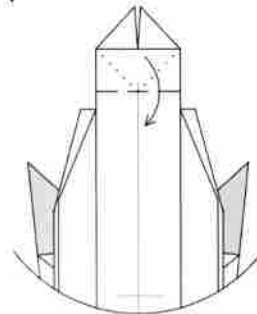

Valley fold.

145

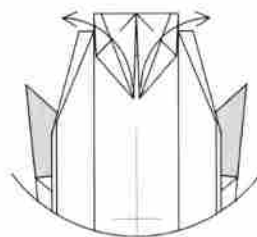

Valley folds.

146

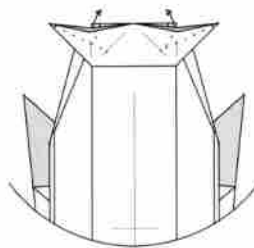

Unfold the layers behind.

147

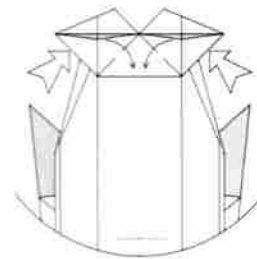

Squash folds.

148

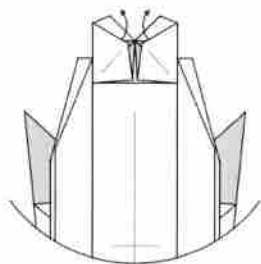

Pull out the raw edges as much as possible. Scale change.

149

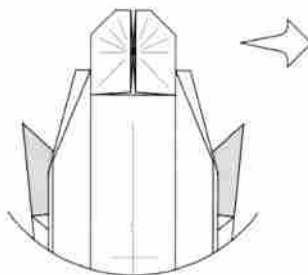

150

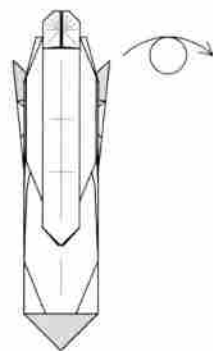

Turn over.

151

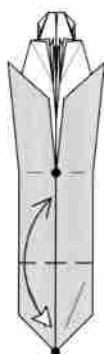

Valley fold and unfold.

152



Open sink.

153

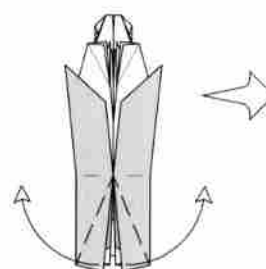

Spread the layers open.

154

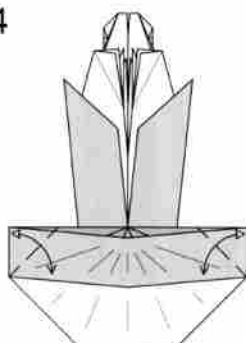

Valley folds and unfold.

155

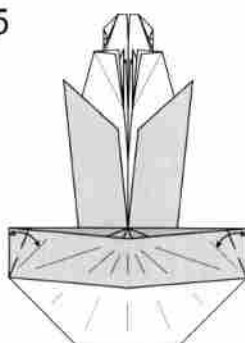

Valley folds and unfold.

156

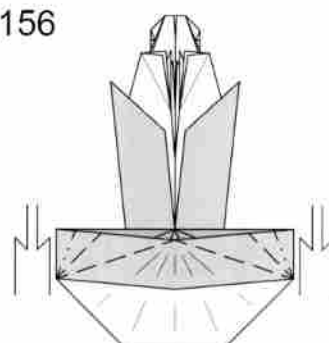

Crimp fold in, out and in.

157

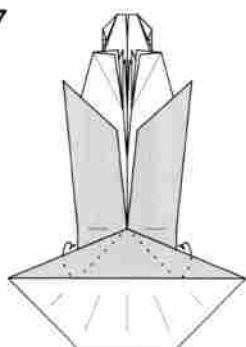

Bring the layers to the front.

158

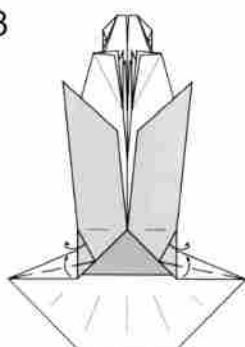

Swivel folds.

159

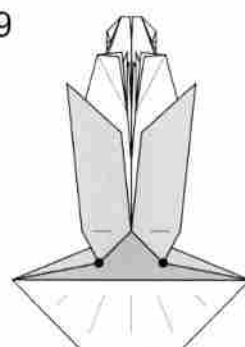

Place inside the layers underneath.

160

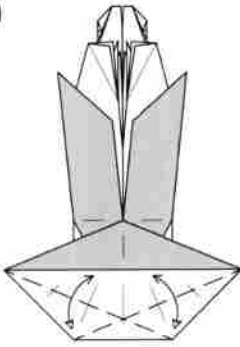

Valley folds and unfold.

161

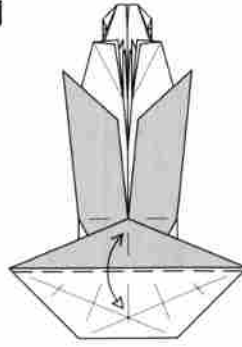

Valley fold and unfold.

162

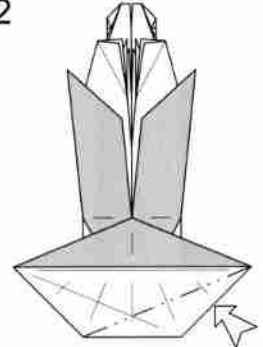

Open sink.

163

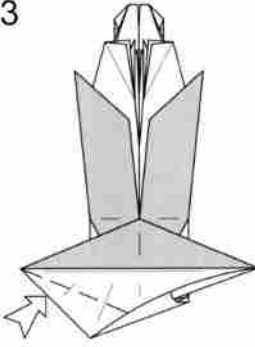

Open sink.

164

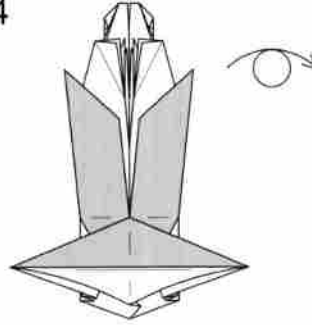

Turn over.

165

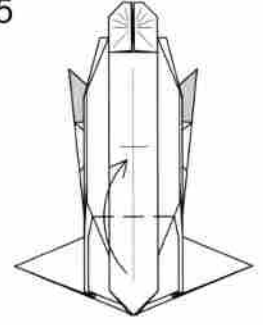

Raise the point.

166

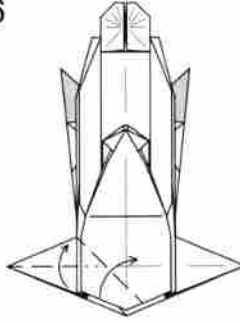

Spread and flatten the layers.

167

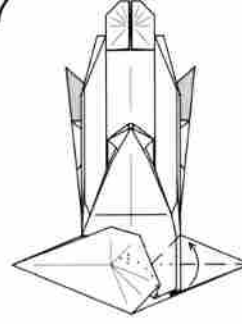

Repeat step 166 on the right.

168

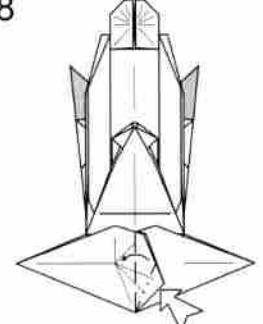

Spread squash.

169

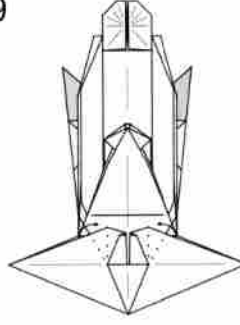

Swivel folds.

170

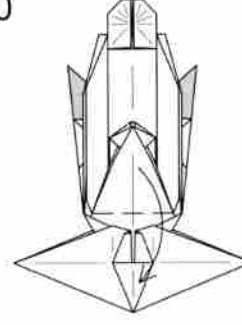

Bring the point down again.

171

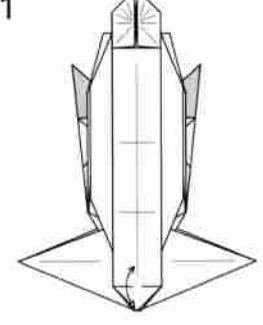

Valley fold and unfold.

172

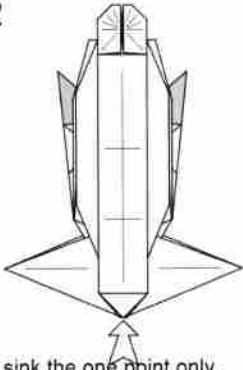

Open sink the one point only.

173

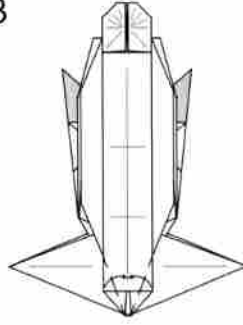

Valley folds.

174

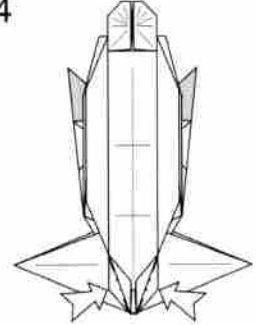

Inside reverse-folds.

175

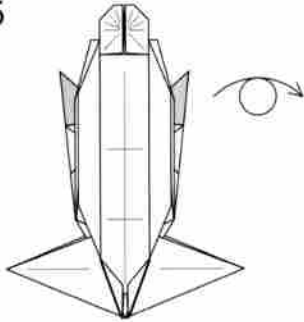

Turn over.

176

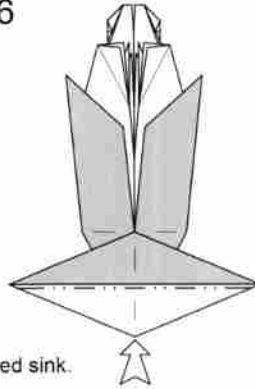

Closed sink.

177

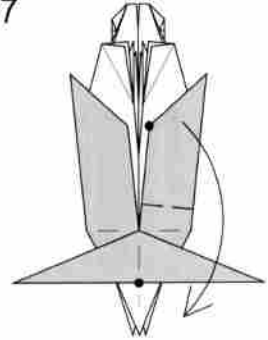

Valley fold.

178

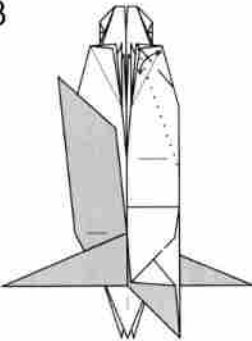

Repeat steps 85 to 88 on this point.

179

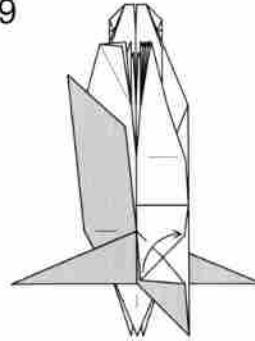

Valley fold.

180

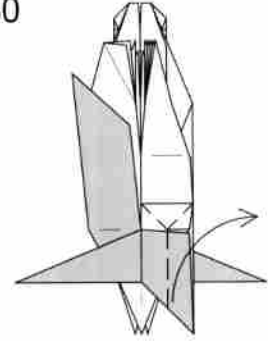

Rabbit-ear.

181

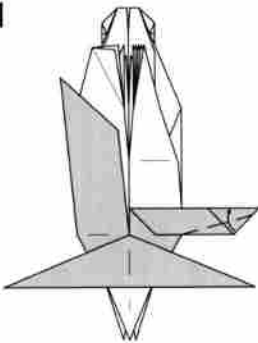

Valley fold.

182

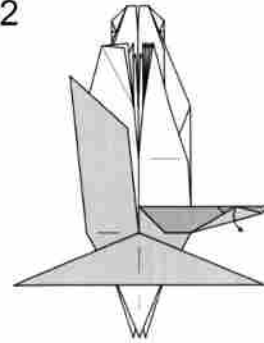

Unfold.

183

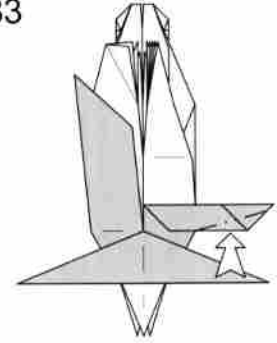

Closed sink.

184

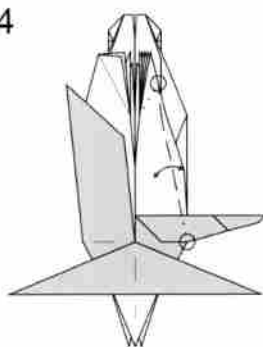

Valley fold and unfold the top layers.

185

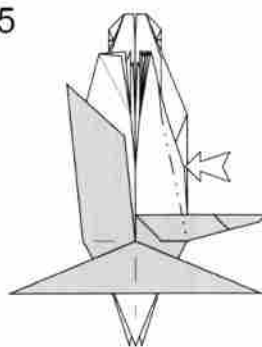

Closed sink.

186

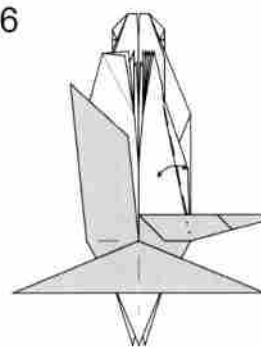

Repeat steps 184 to 185 on the next layers.

187

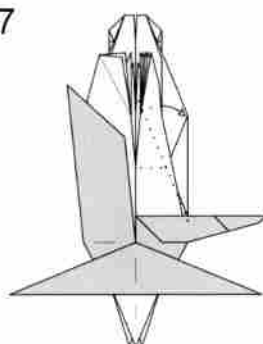

Slide the internal point outward.

188

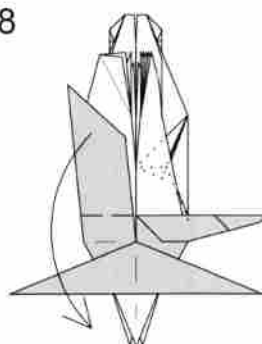

Repeat steps 177 to 187 on the left.

189

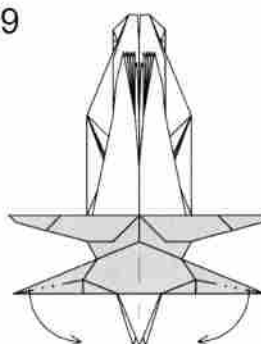

Double rabbit-ear the hind legs.

190

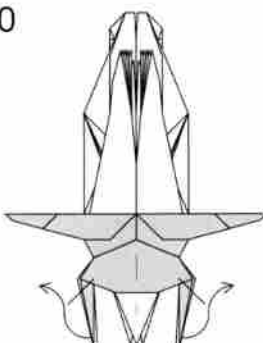

Inside reverse-folds.

191



Mountain fold in half and rotate.

192

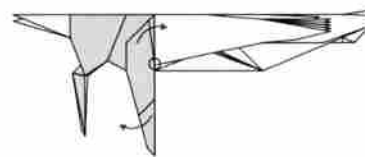

Pivot the front legs.

193

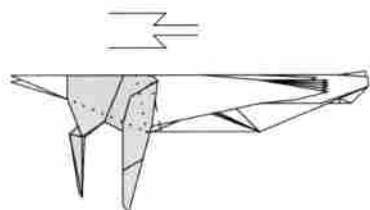

Crimp fold.

194

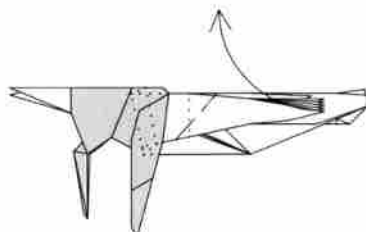

Valley-fold the thick flap. Repeat behind.

195

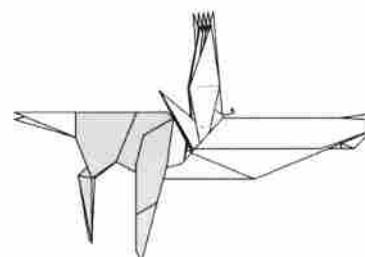

Swivel fold behind to thin the flap. Repeat behind.

196

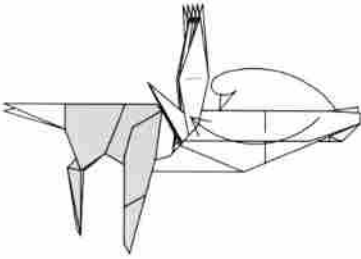

Outside reverse-fold and place the split-point around the base of the antlers.

197

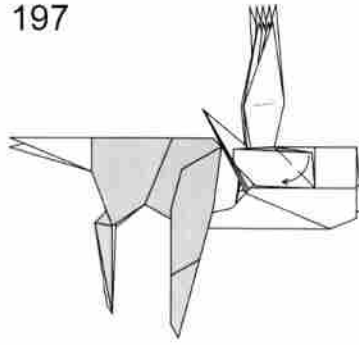

Valley fold. Repeat behind.

198

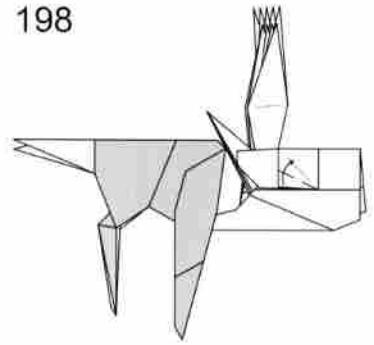

Valley fold and shape the eye. Repeat behind.

199

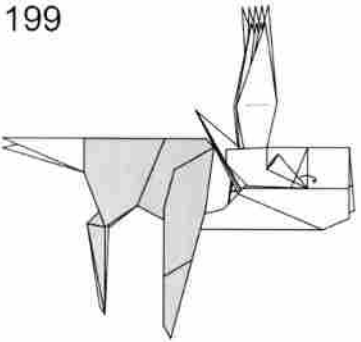

Mountain fold. Repeat behind.

200

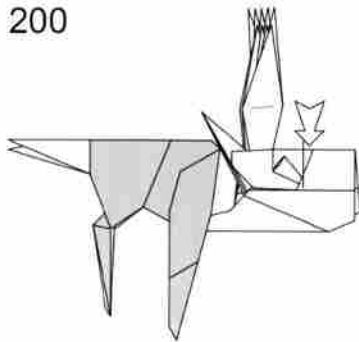

Inside reverse-fold.

201

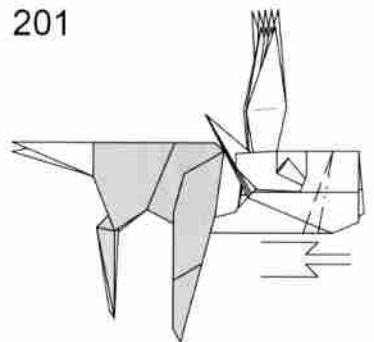

Outside crimp fold.

202

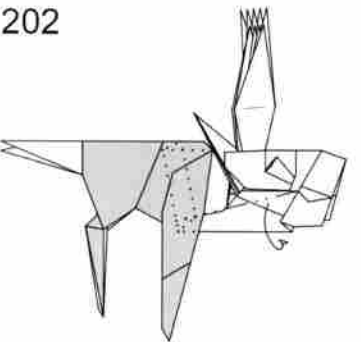

Shape with mountain-folds and swivel-folds. Repeat behind.

203

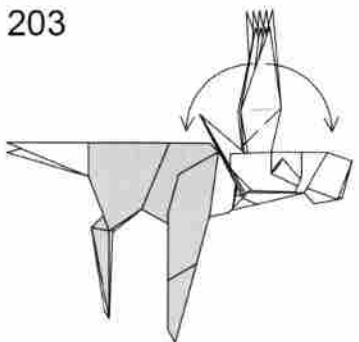

Valley fold and spread the two flaps. Repeat behind.

204

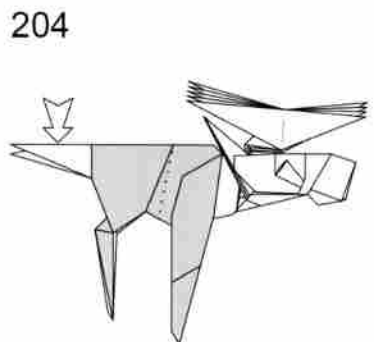

Reverse-fold the point and form the bell.

205

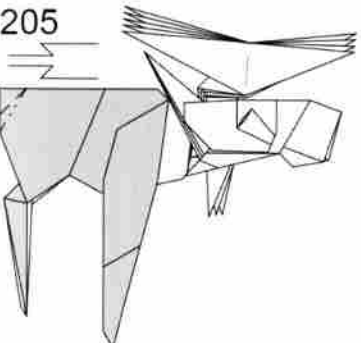

Crimp fold the tail.

206

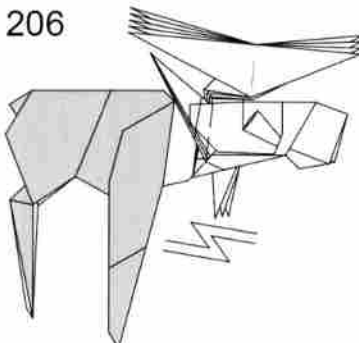

Shape the ears with pleat-folds.

207

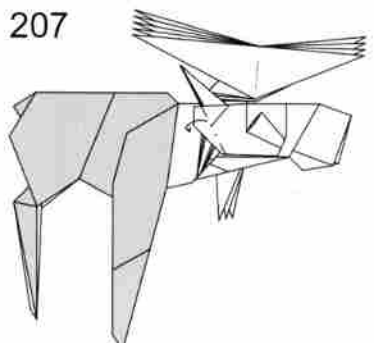

Shape the layers over the top of the ears.

208

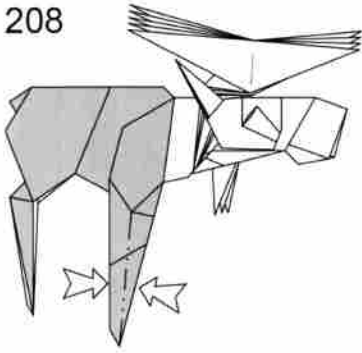

Pinch the front legs.

209

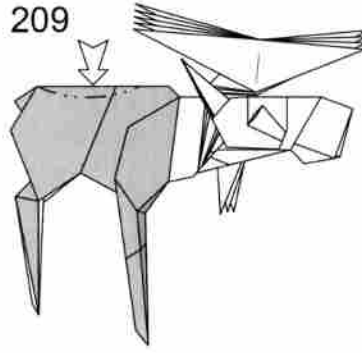

Shape the back and shoulders.

210

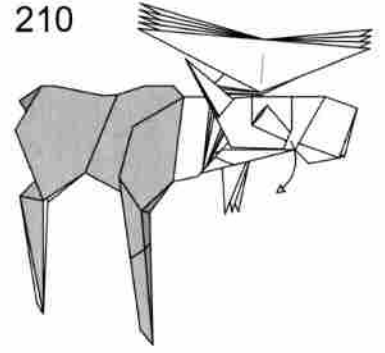

Rotate the head down.

211

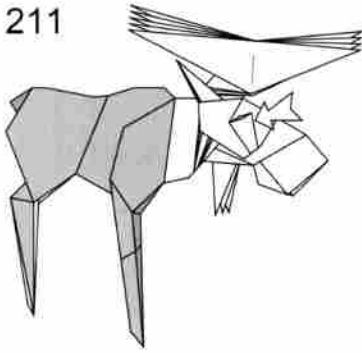

Shape the eyes.

212

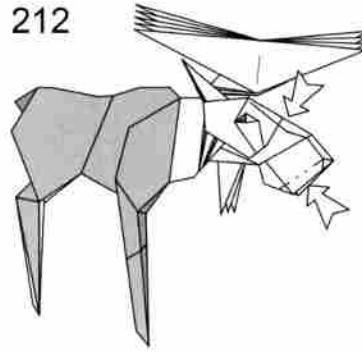

Shape the head.

213

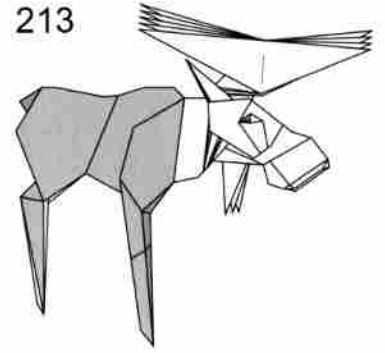

Shape the antlers.

214

215

216

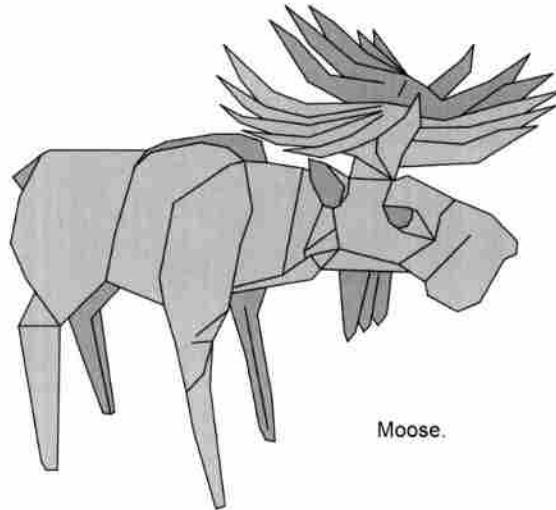

Moose.



# 옷을 입은 토끼 Dressed rabbit

by Kota Imai : Japan  
Diagram by Kota Imai

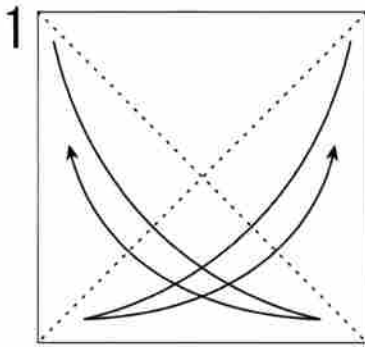

1 対角線に折り筋を付けて裏返す

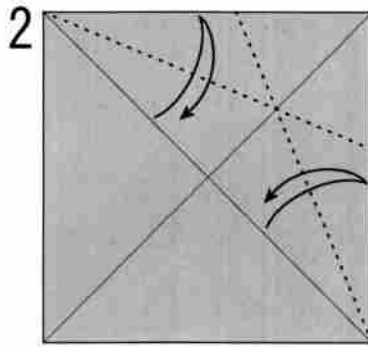

2 辺と折り筋を合わせて折り筋を付ける

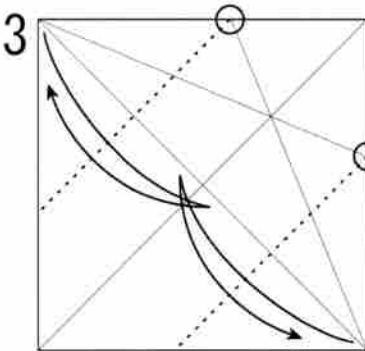

3 ○を通る線で折り筋を付ける

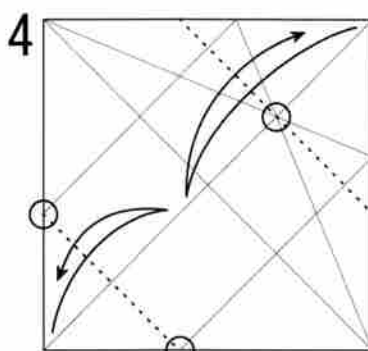

4 ○を通る線で折り筋を付ける

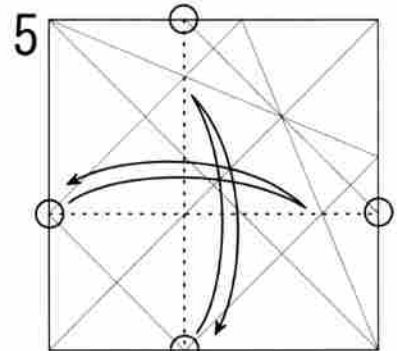

5 ○を結ぶ線で折り筋を付ける

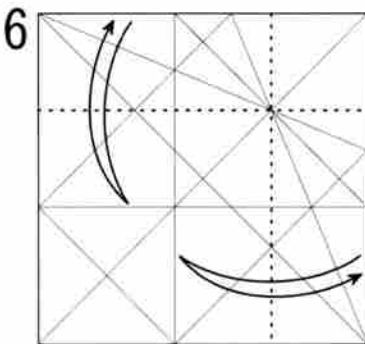

6 辺と折り筋を合わせて折り筋を付けて裏返す

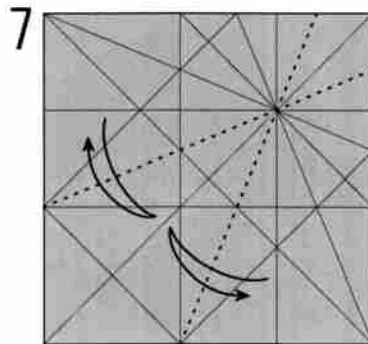

7 折り筋と折り筋を合わせて折り筋を付ける

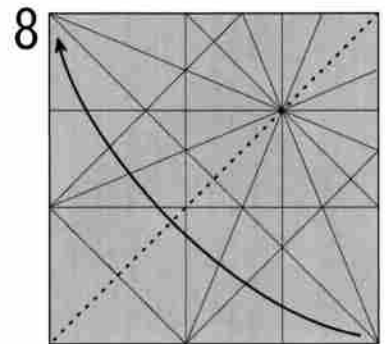

8 半分に折る

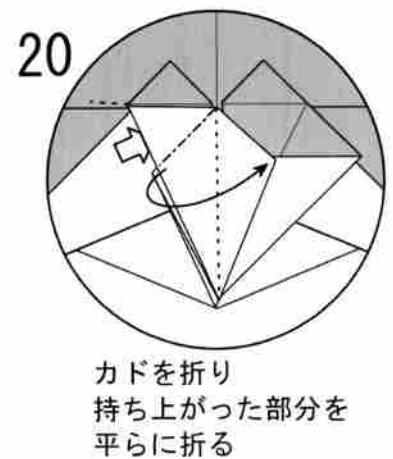
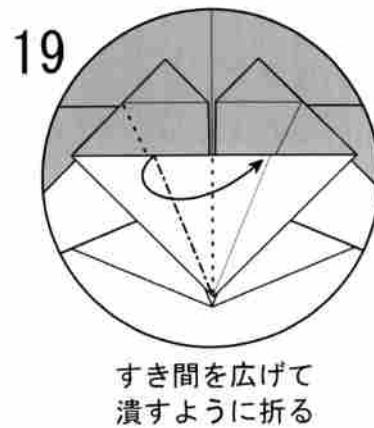
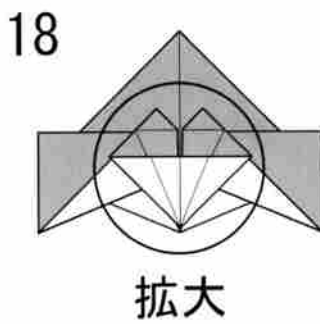
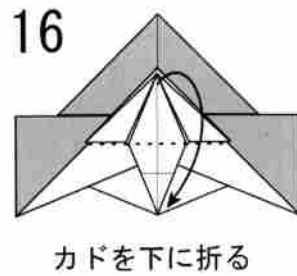
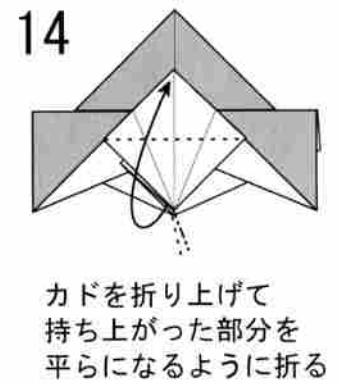
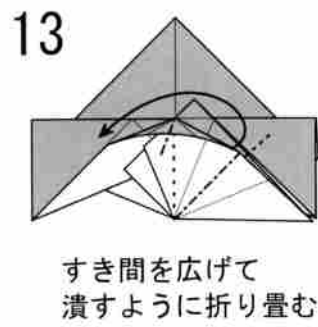
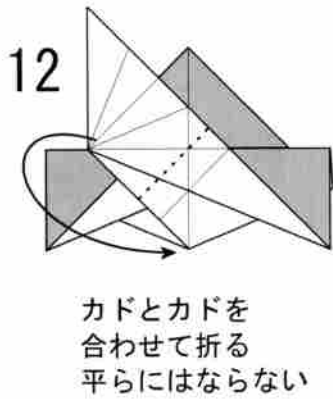
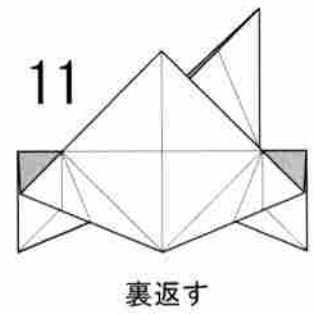
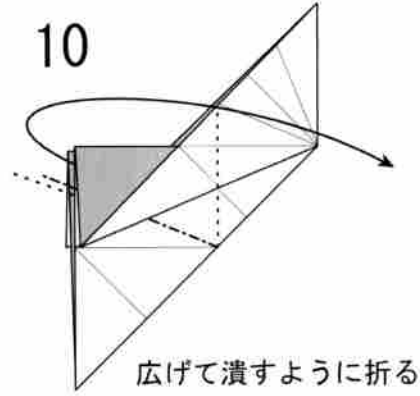
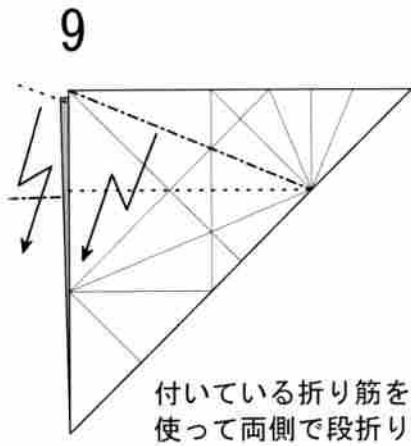

21

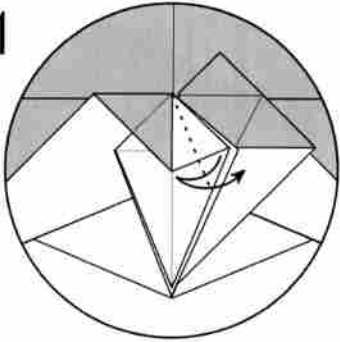

フチを折り筋に合わせて  
折り筋を付ける

22

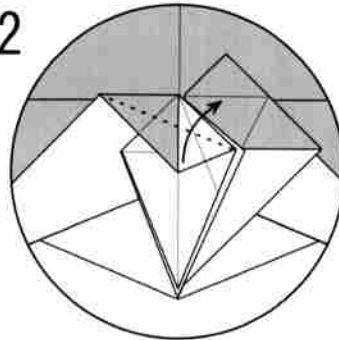

フチを折り筋に  
合わせて折る

23

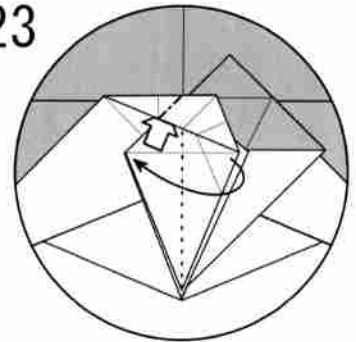

すき間を広げて  
起き上がったカドを  
倒すように折る

24

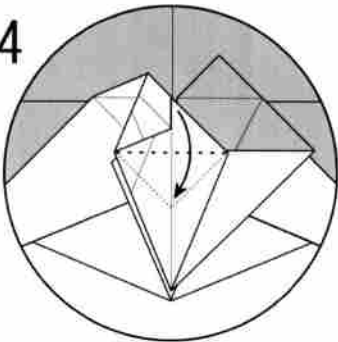

カドを内側から  
引き出すように折る

25

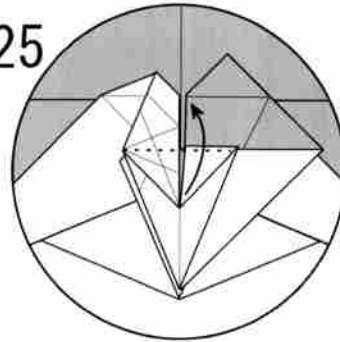

カドを上折る

26

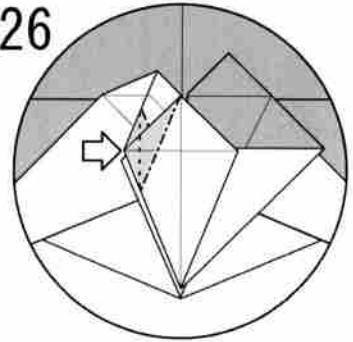

折り筋を使って  
灰色部分を  
沈めるように折る

27

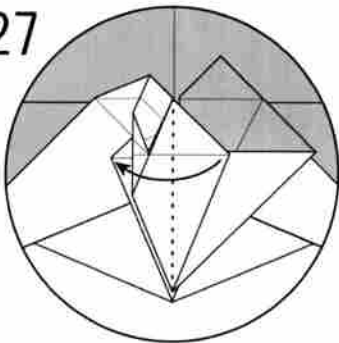

カドを左に折る

28

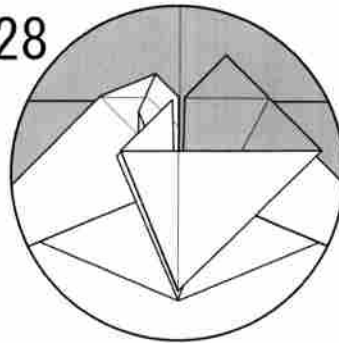

反対側も19~27と  
同じように折る

29

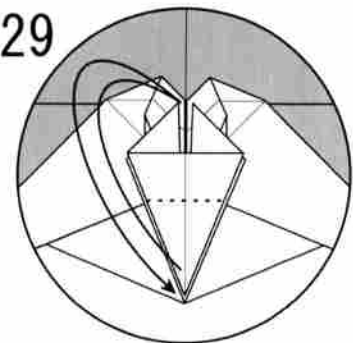

カドとカドを合わせて  
折り筋を付ける

30

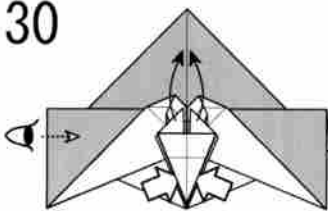

カドを引き上げながら  
軽くすき間を広げる  
次の図は視点が変わる

31

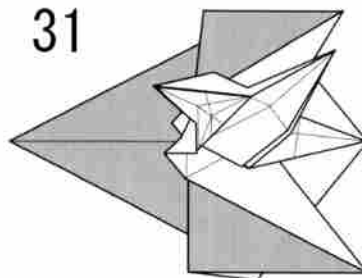

途中の図

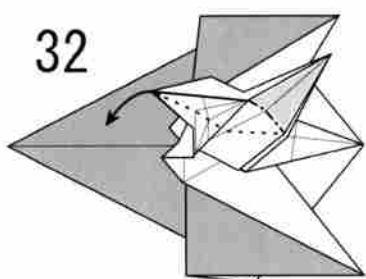

32

カドをさらに引っ張り  
灰色部分を膨らませる  
ように折る

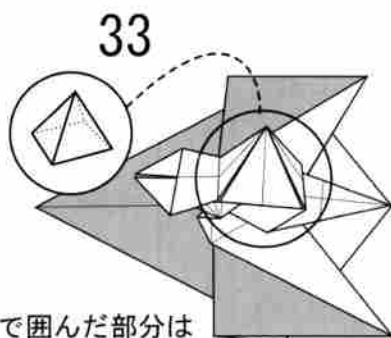

33

丸で囲んだ部分は  
ピラミッド形になる

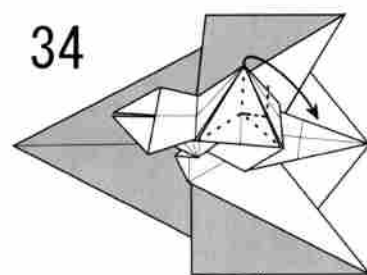

34

カドをつまんで倒し  
平らに折り畳む

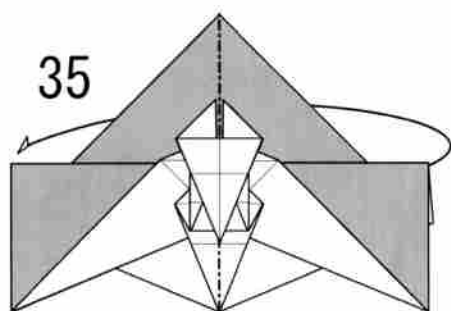

35

一番手前以外のカドを  
後ろへ半分に折る

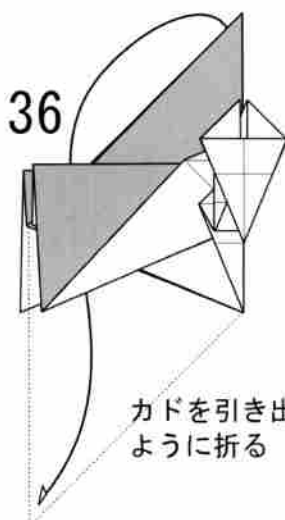

36

カドを引き出す  
ように折る

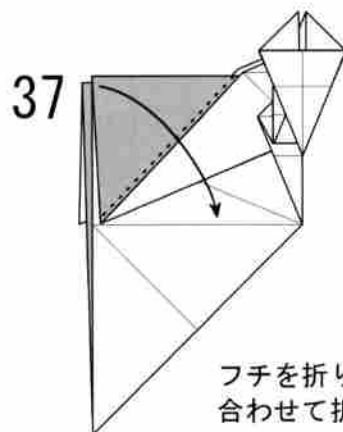

37

フチを折り筋に  
合わせて折る

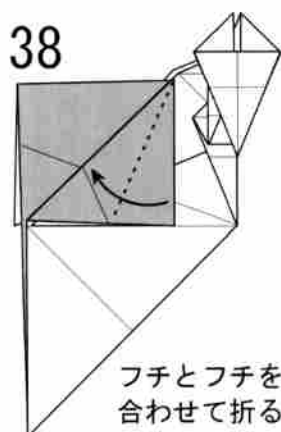

38

フチとフチを  
合わせて折る

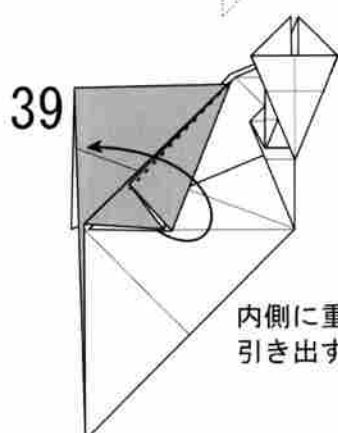

39

内側に重なった紙を  
引き出すように折る

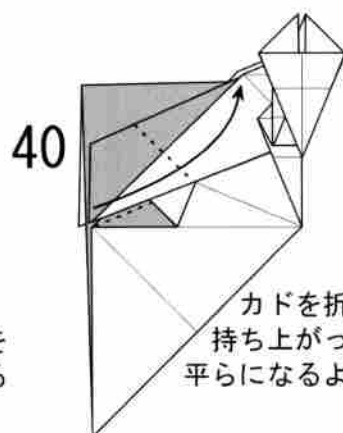

40

カドを折り上げて  
持ち上がった部分を  
平らになるように折る

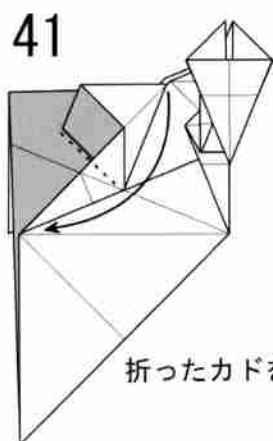

41

折ったカドを戻す

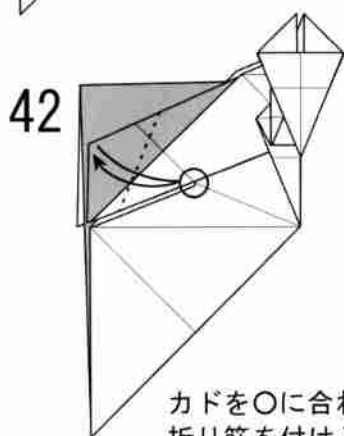

42

カドを○に合わせて  
折り筋を付ける

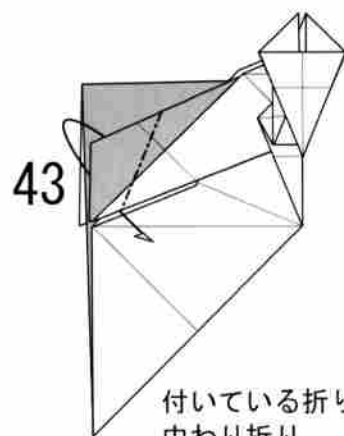

43

付いている折り筋で  
中わり折り

44

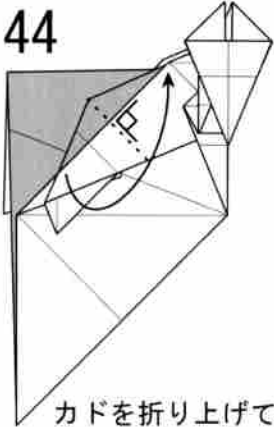

カドを折り上げて  
持ち上がった部分を  
平らになるように折る

45

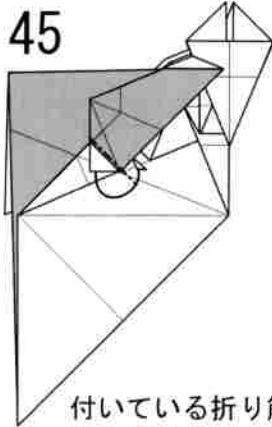

付いている折り筋で  
中わり折り

46

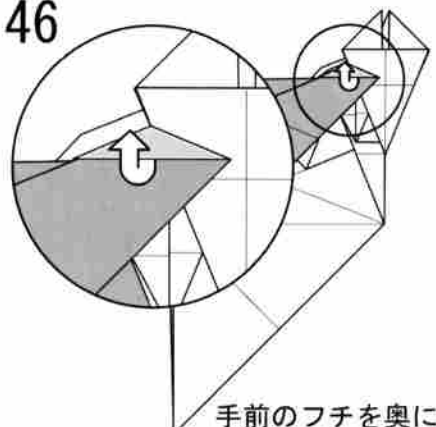

手前のフチを奥に  
かぶせるように折る

47

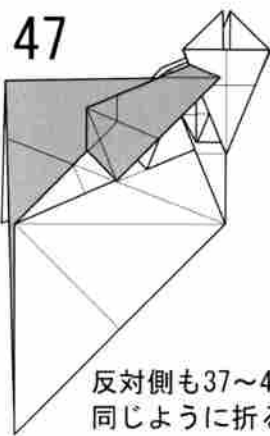

反対側も37~46と  
同じように折る

48

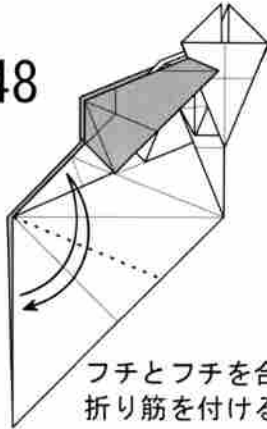

フチとフチを合わせて  
折り筋を付ける

49

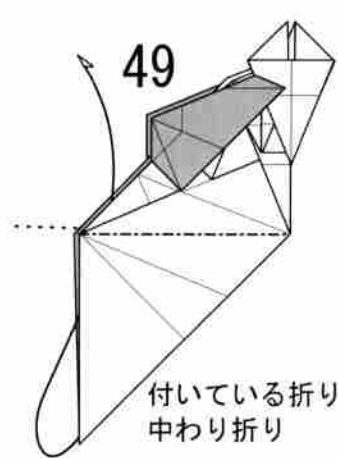

付いている折り筋で  
中わり折り

50

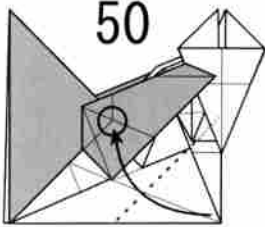

カドをOに  
合わせて折る

51

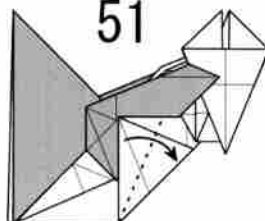

フチとフチを  
合わせて折る

52

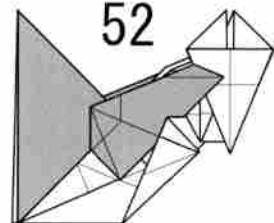

50の状態まで戻す

53

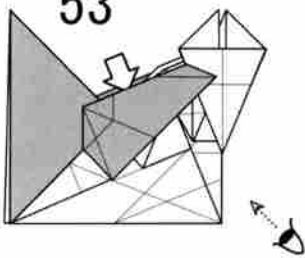

後ろのすき間を広げる  
次の図は視点が変わる

54

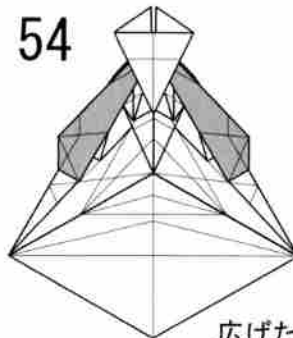

広げた図

55

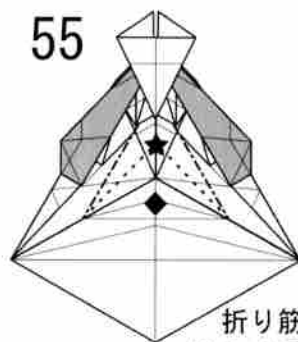

付いている  
折り筋で★部分を  
凹ませるように折る

56

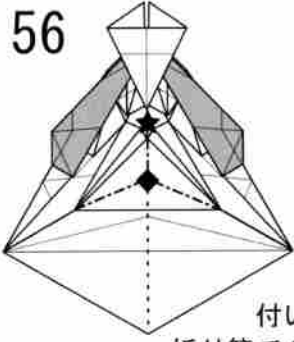

付いている  
折り筋で◆部分が  
突き出るように折り畳む

57

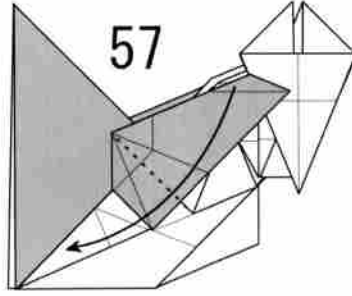

カドを下に折る

58

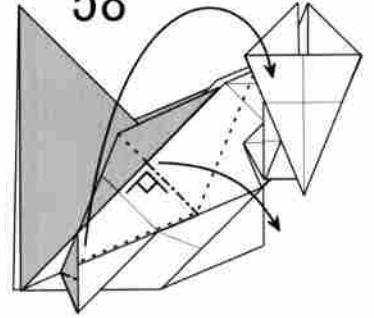

紙を引き出しながら  
折ったカドを戻す

59

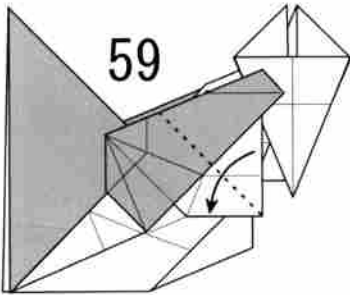

フチとフチを  
合わせて折る

60

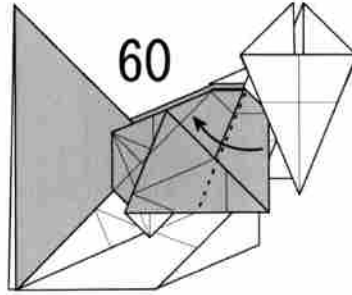

フチを折り筋に  
合わせて折る

61

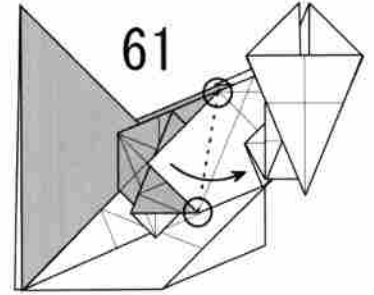

○を結ぶ線で折る

62

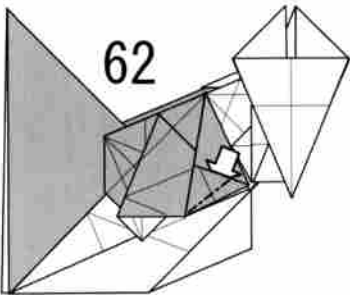

すき間を広げて紙を  
引き出すように折る

63

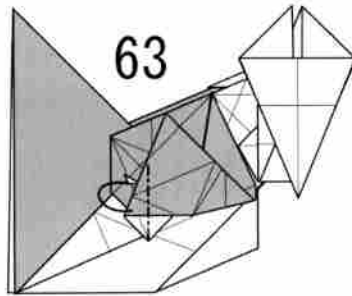

付いている折り筋で  
内側に折る

64

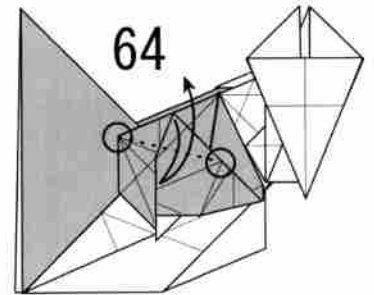

○を結ぶ線で  
折り筋を付ける

65

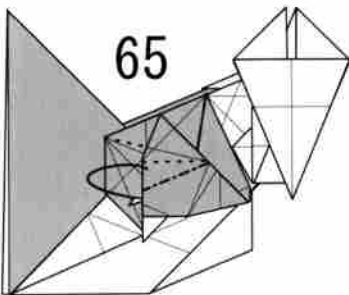

付いている折り筋で  
中わり折り

66

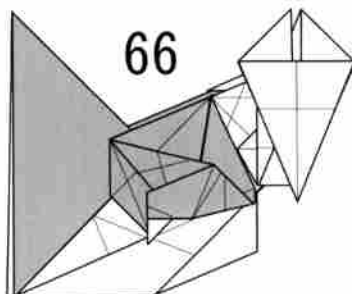

反対側も57~65と  
同じように折る

67

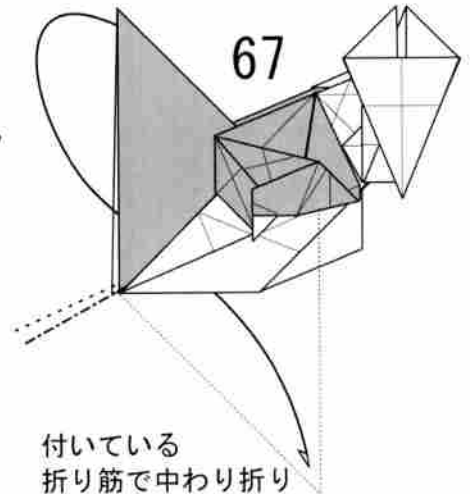

付いている  
折り筋で中わり折り

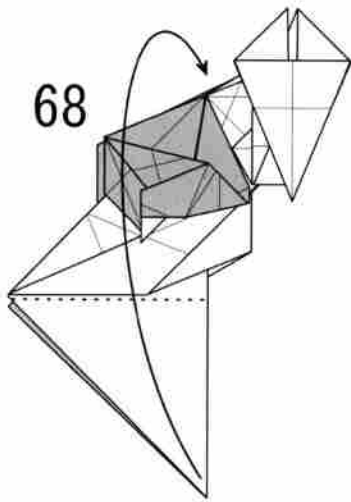

68

付いている折り筋で  
カドを上折る

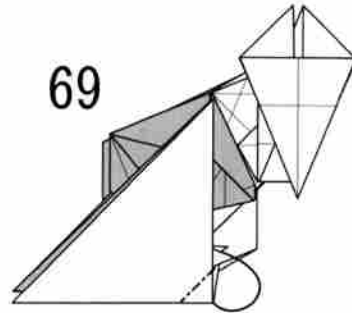

69

カドを少し中わり折り

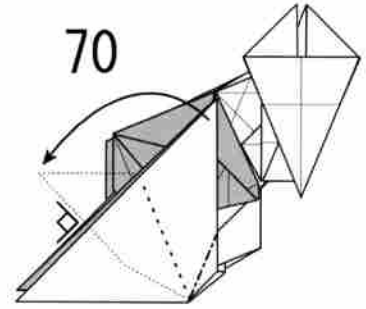

70

フチとフチが垂直になる  
ようにカドを折る

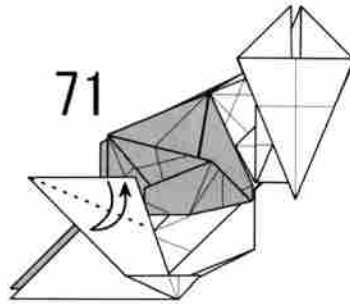

71

フチとフチを合わせて  
折り筋を付ける

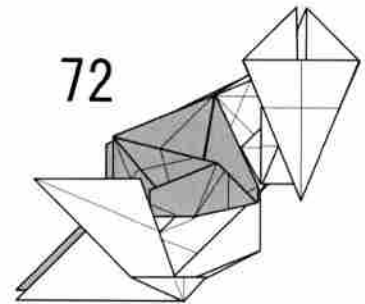

72

68の状態まで戻す

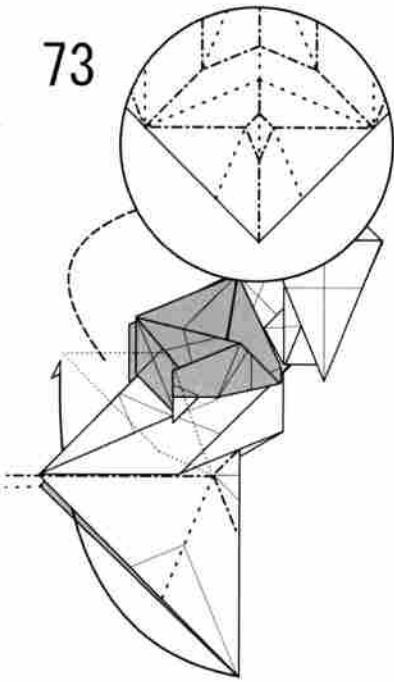

73

展開図を参考に  
付いている折り筋で  
カドを折り上げる

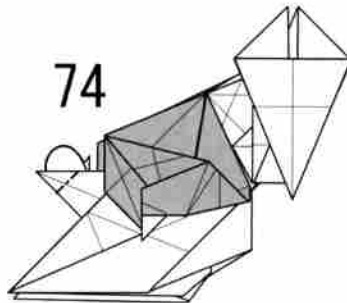

74

カドを少し中わり折り

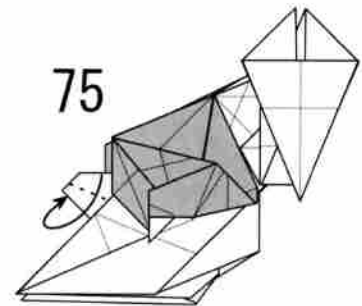

75

付いている折り筋で  
カドを細くするように折る  
反対側も同じ

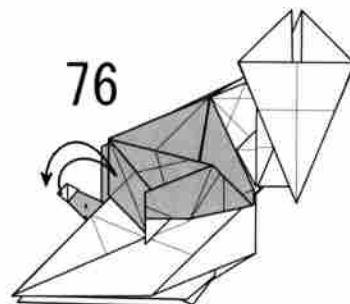

76

フチとフチを合わせて  
折り筋を付ける

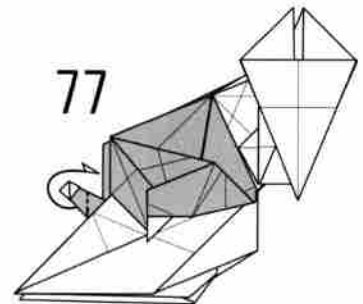

77

付いている折り筋で  
両側でかぶせ折り

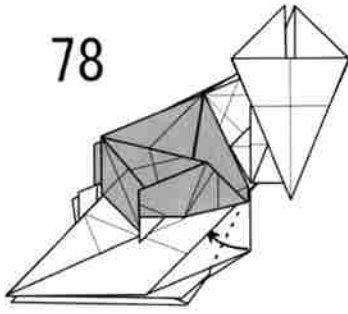

78

カドをすき間に  
差し込むように折る

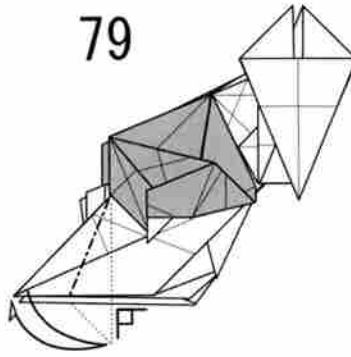

79

フチとフチが垂直に  
なるように山折りの  
折り筋を付ける

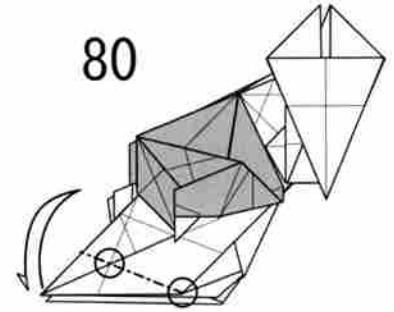

80

○を通る線で山折りの  
折り筋を付ける

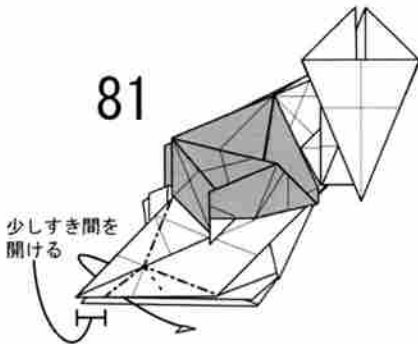

81

少しすき間を  
開ける

付いている折り筋で  
カドをつまむように折る

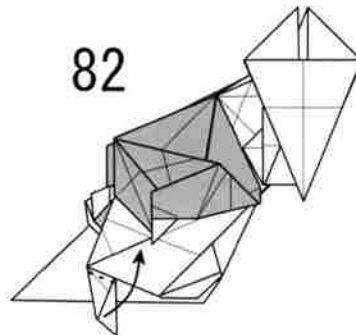

82

カドを上折る

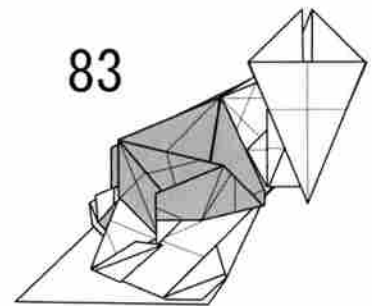

83

反対側も79~82と  
同じように折る

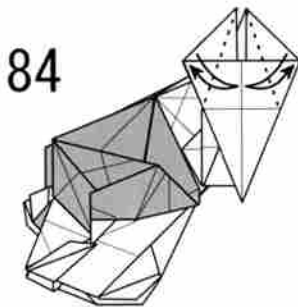

84

フチと折り筋を合わせて  
折り筋を付ける

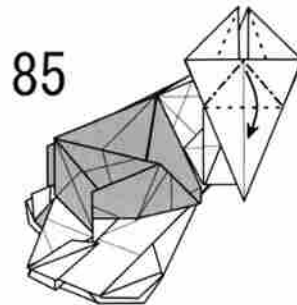

85

内側を広げて  
潰すように折る

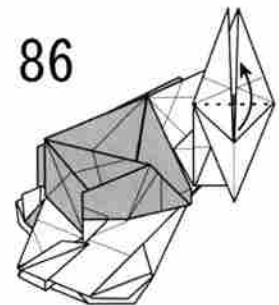

86

カドを上折る

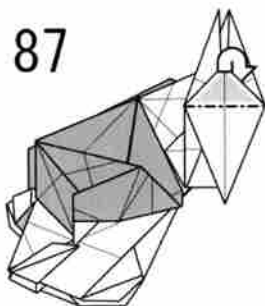

87

灰色部分を内側に  
沈めるように折る

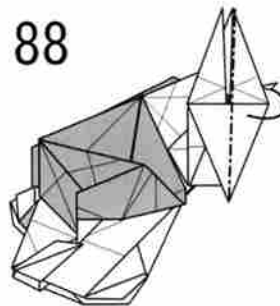

88

カドを奥に折る  
紙が破けないように注意

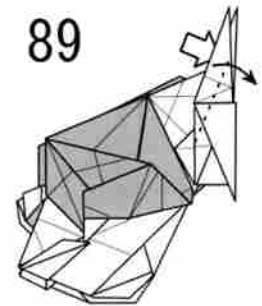

89

手前から2番目の隙間を  
広げるように折る  
反対側も同じように折る



90

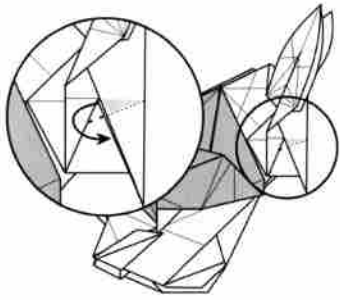

カドを少し折る  
反対側も同じように折る

91

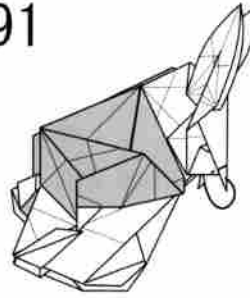

先端を少し中わり折り

92

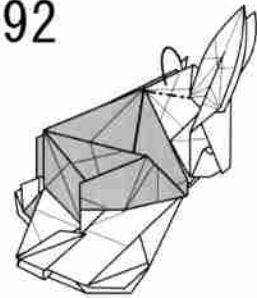

カドを折れるところまで  
内側に折る  
反対側も同じように折る

93

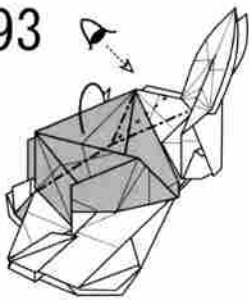

図のように折り  
胴体を立体的にする  
反対側も同じように折る  
次の図は視点が変わる

94

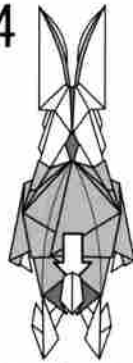

内側を膨らませる  
ように折る

95



96

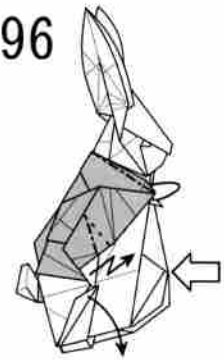

各部を仕上げる

97

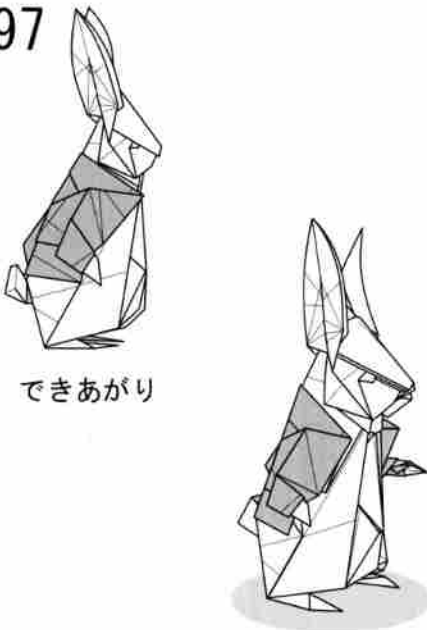

できあがり

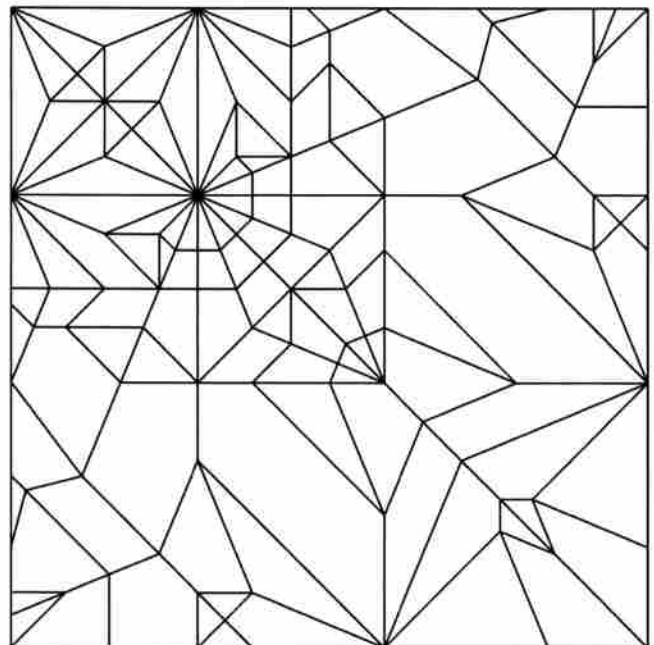

# 호랑나비 Swallowtail

by Kota Imai : Japan

Diagram by Kota Imai

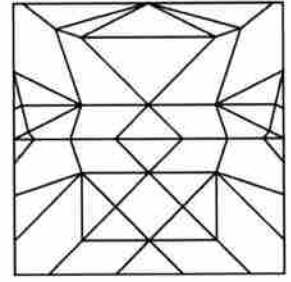

1

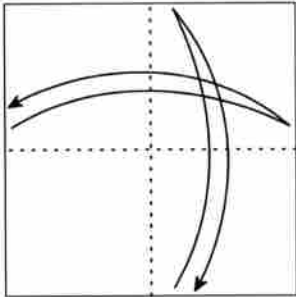

辺と辺を合わせて  
折り筋を付ける

2

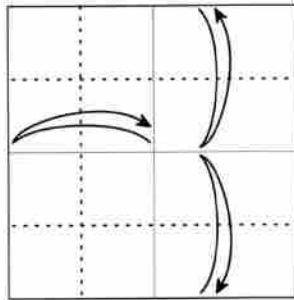

辺と折り筋を合わせて  
折り筋を付ける

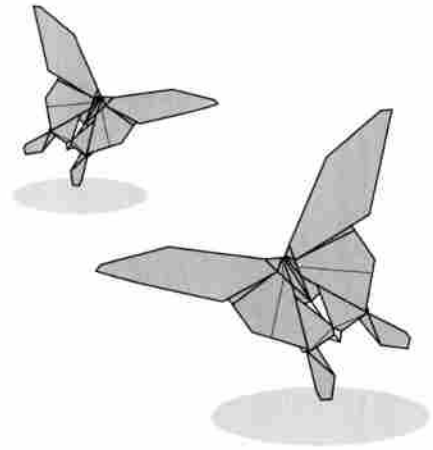

3

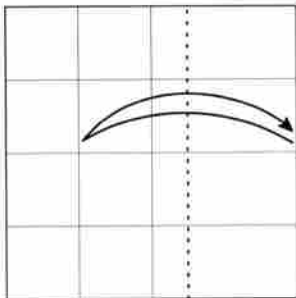

辺と折り筋を合わせて  
折り筋を付ける

4

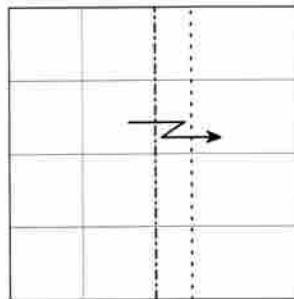

付いている折り筋で  
段折り

5

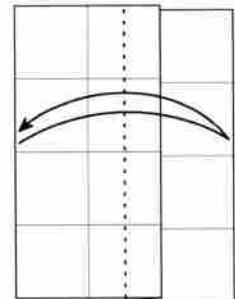

辺と辺を合わせて  
折り筋を付ける

6

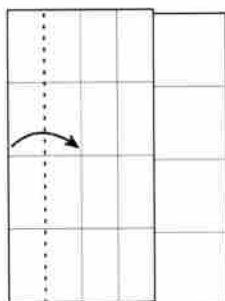

辺を折り筋に  
合わせて折る

7

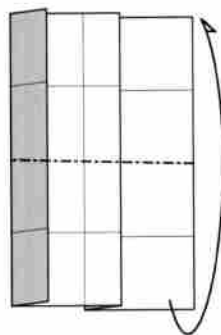

全体を半分に  
山折り

8

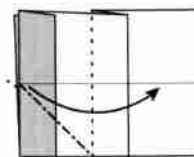

広げて潰すように折る

9

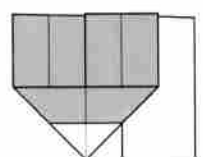

裏返す

10

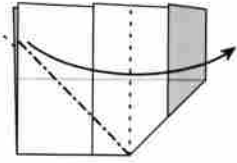

広げて潰すように折る

11

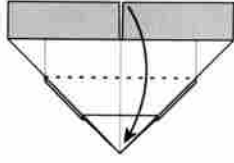

フチをカドに合わせて折る

12

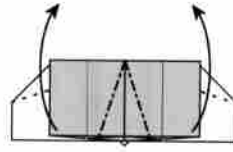

手前のすき間で  
広げて潰すように折る

13

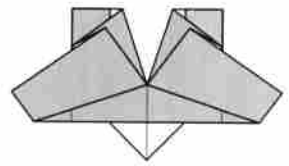

裏返す

14

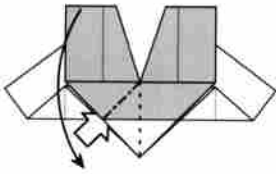

広げて潰すように折る

15

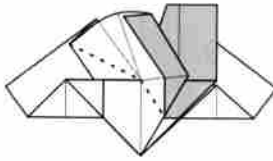

途中の図

16

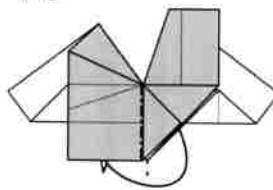

付いている折り筋で  
中わり折り

17

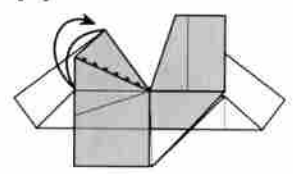

フチを折り筋に  
合わせて折る

18

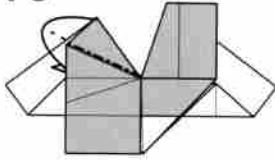

付いている折り筋で  
中わり折り

19

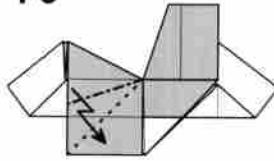

紙をずらすように  
段折り

20

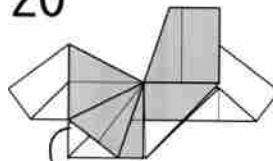

紙を引き出す  
ように折る

21

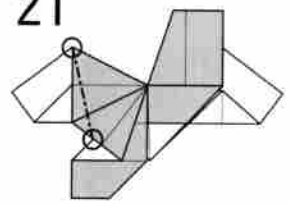

○を結ぶ線で山折り

22

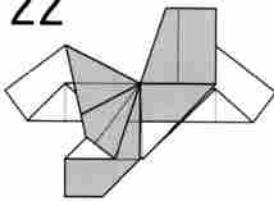

反対側も14~20と  
同じように折る

23

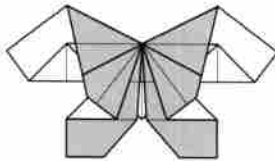

裏返す

24

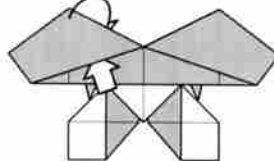

カドを奥に倒しながら  
すき間を広げる  
平らにはならない

25

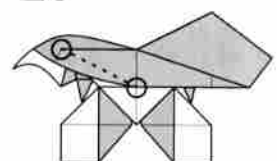

丸を結ぶ線で折る

26

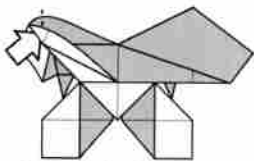

すき間を広げながら  
折り筋をフチまで  
延長するように折る

27

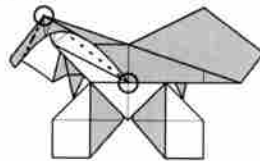

○を結ぶ線で折り  
平坦に畳む

28

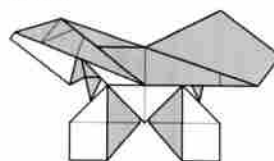

反対側も23~26と  
同じように折る

29

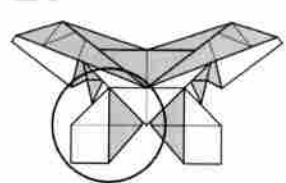

一部拡大

30

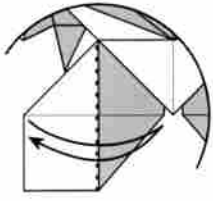

カドとカドを  
合わせて折る

31

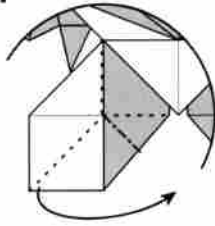

カドをつまんで  
倒すように折る

32

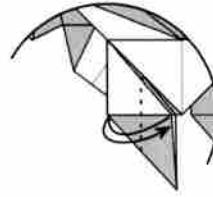

カドとカドを合わせて  
折り筋を付ける

33

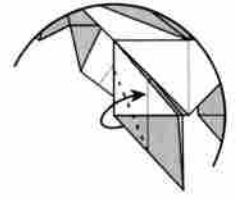

フチを折り筋に  
合わせて折る

34

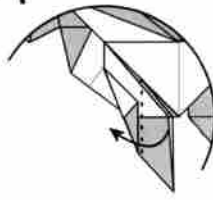

カドを左に折る

35

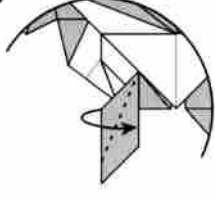

フチを折り筋に  
合わせて折る

36

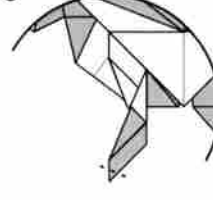

カドの先端を  
少し折る

37

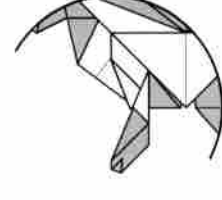

拡大終了

38

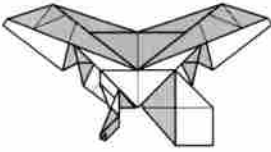

反対側も29~35と  
同じように折る

39



裏返す

40



フチを折り筋に  
合わせて折る

41

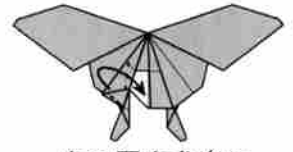

次の図を参考に  
カドを折る

42



39の状態まで  
戻す

43

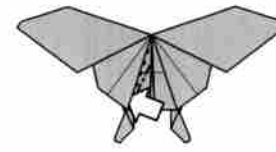

すき間に差し込む  
ように段折り

44

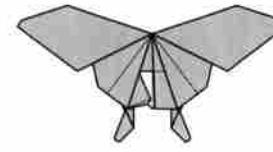

反対側も39~42と  
同じように折る

45

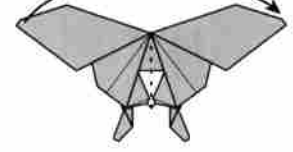

全体を半分折る

46

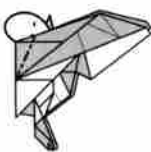

カドを少し  
中わり折り

47

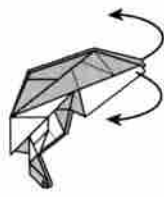

軽く広げる

48

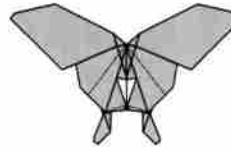

できあがり

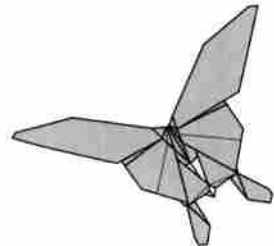

# 토끼 Rabbit

by Elver Ventura : Peru  
Diagram by Javier Vivanco

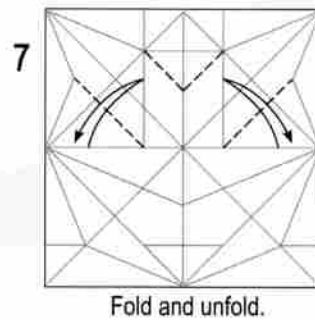
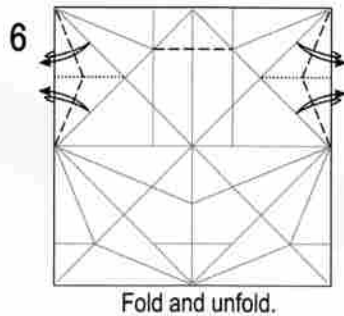
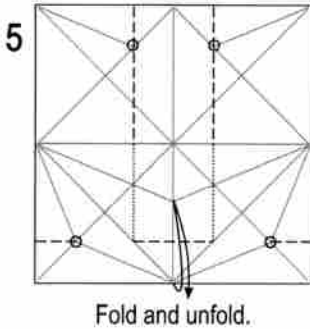
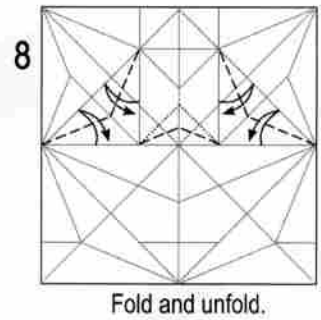
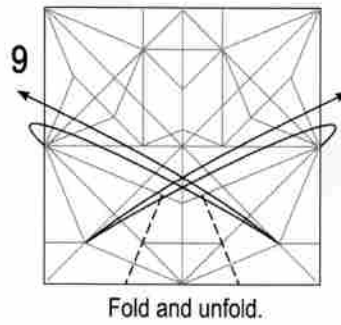
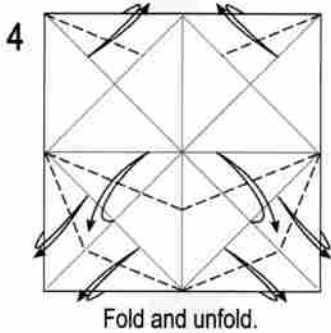
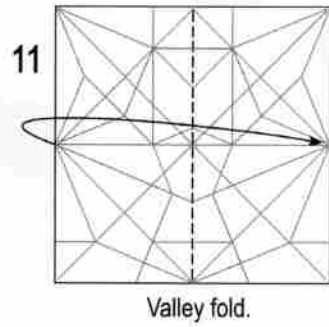
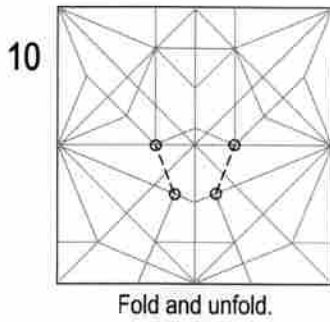
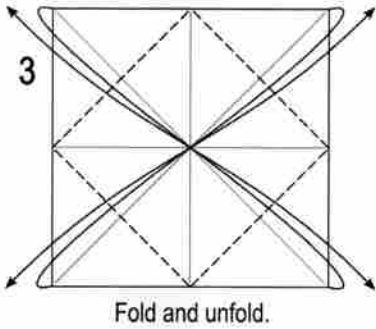
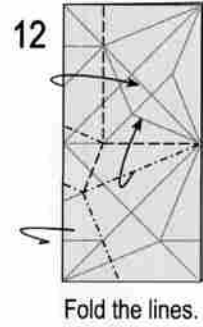
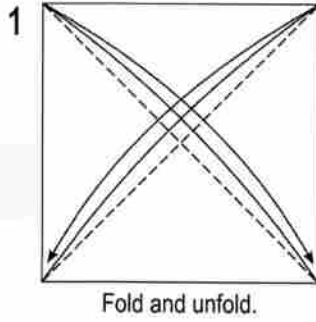
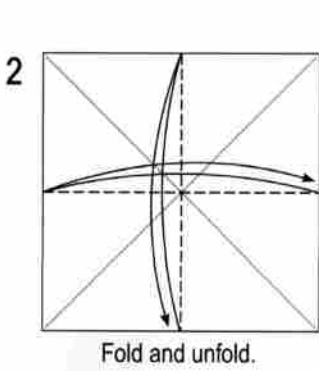
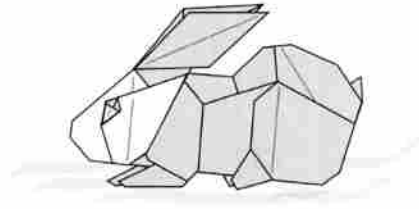

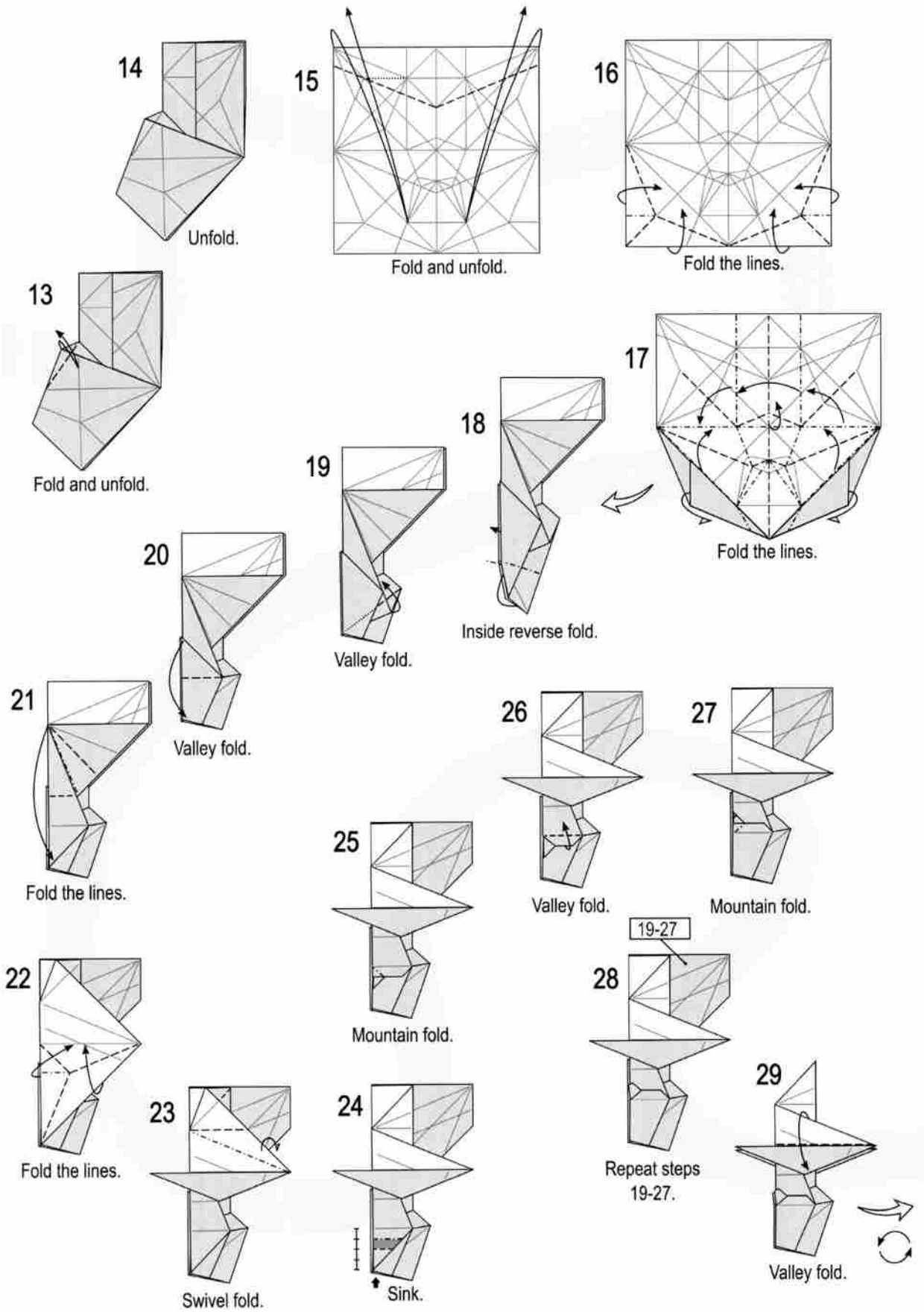

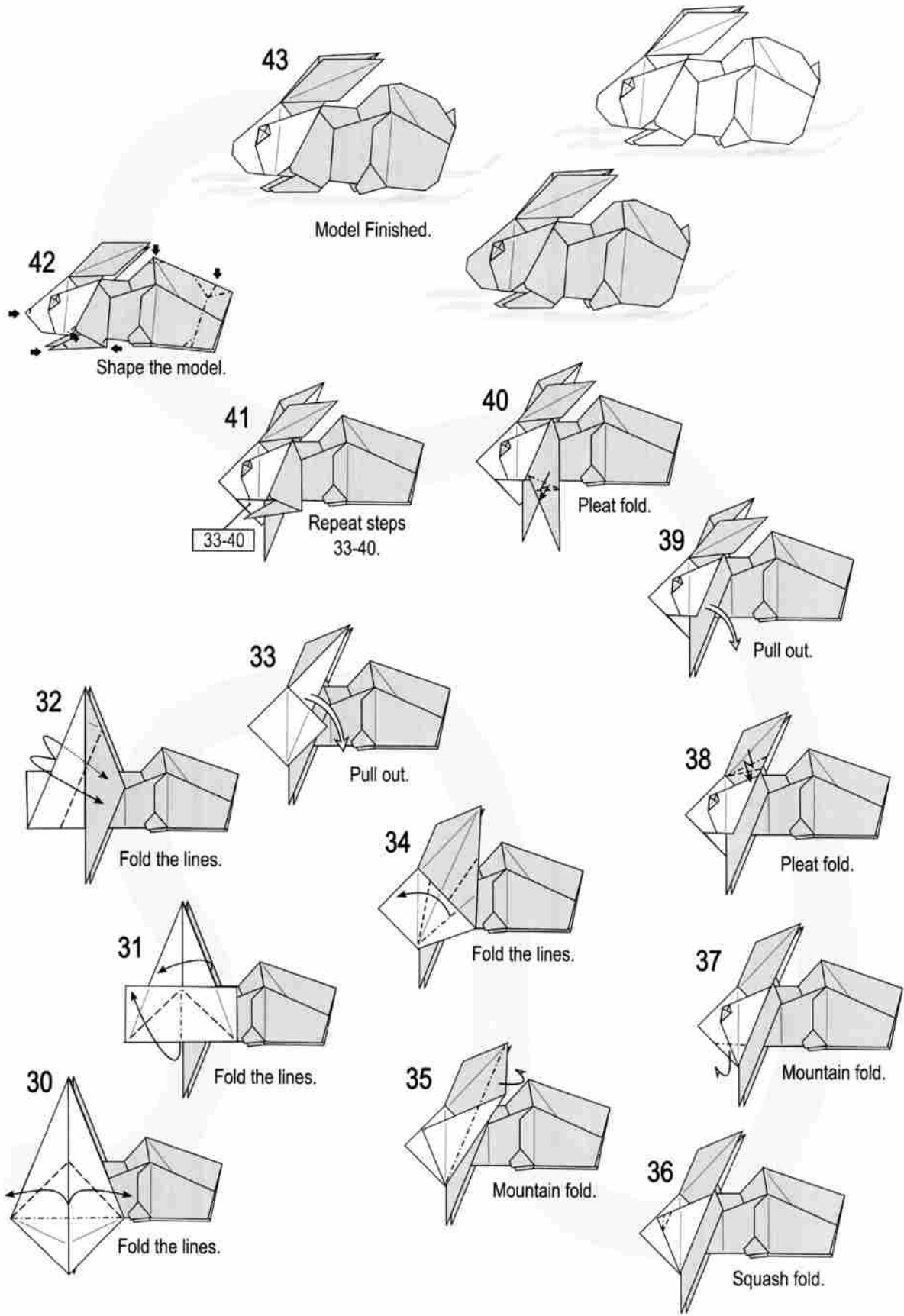

# 작은 여우 Little Fox

by Hiroaki Kobayashi : Japan

Diagram by Hiroaki Kobayashi

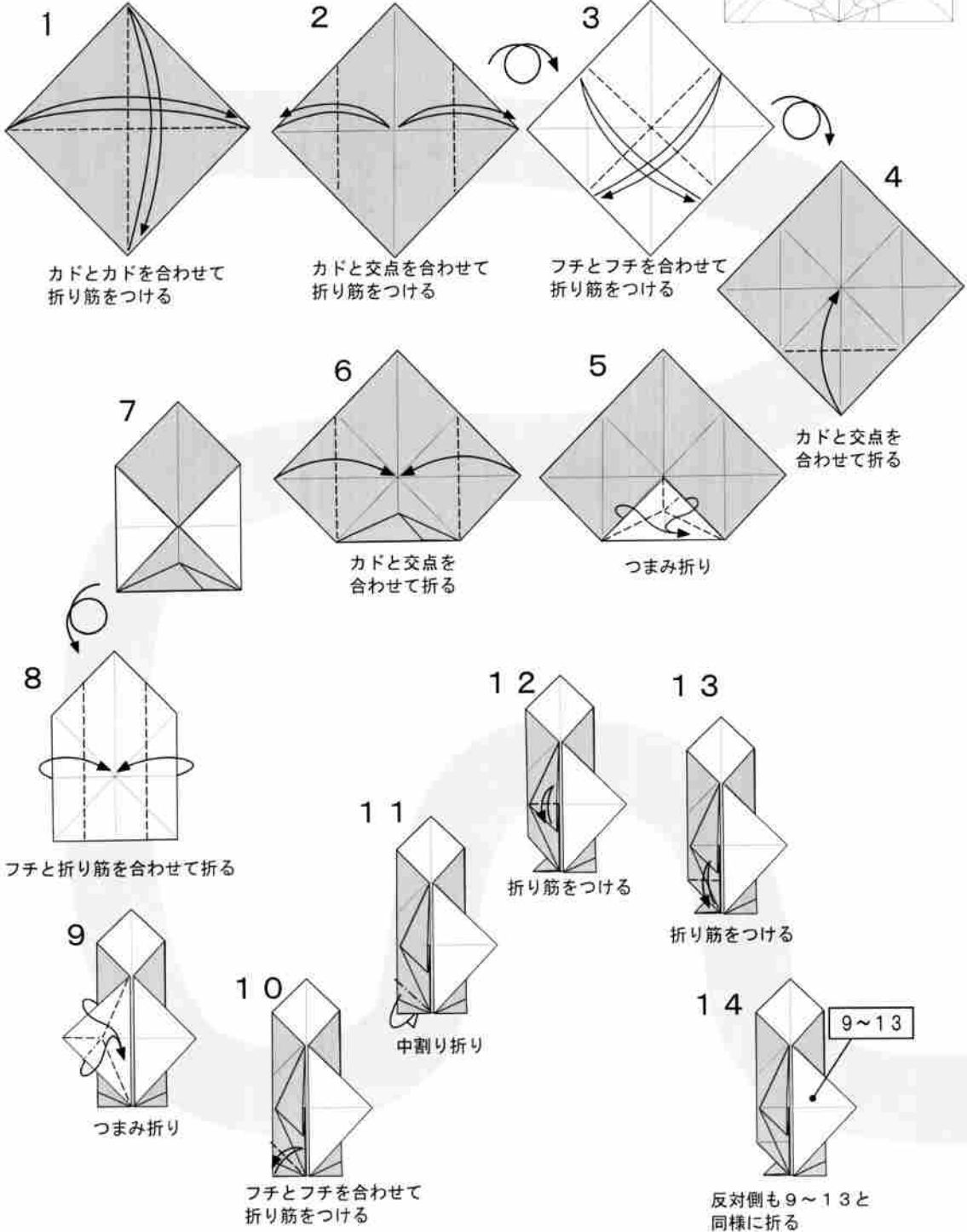
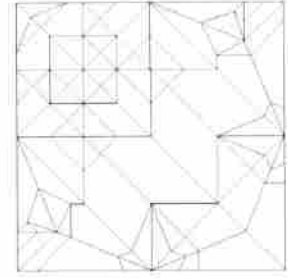
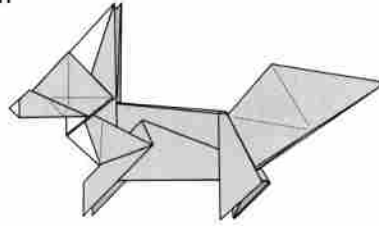



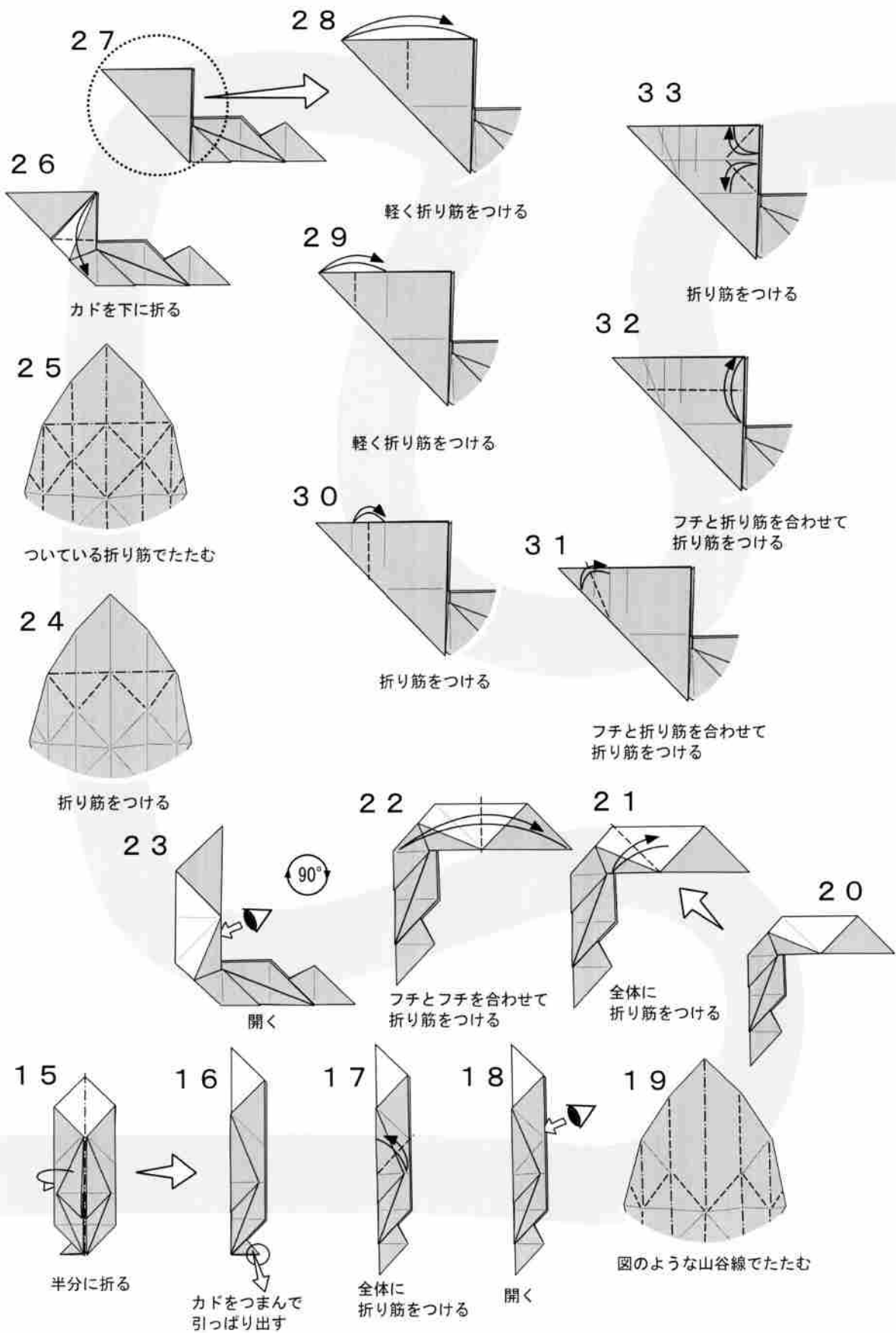

34

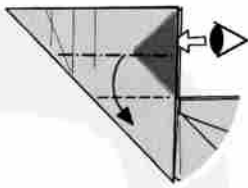

内側の色部分をつぶすように折る

35

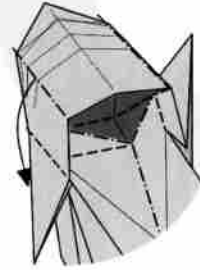

途中図

36

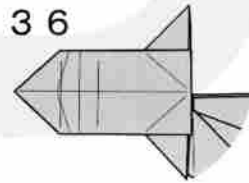

37

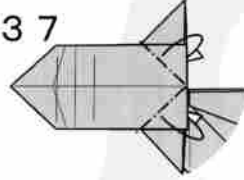

ついている折り筋で山折り

38

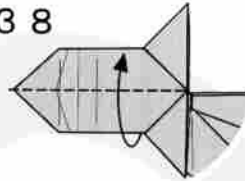

39

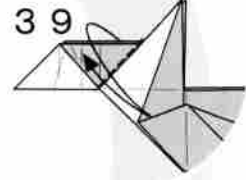

まとめて折り筋をつける

40

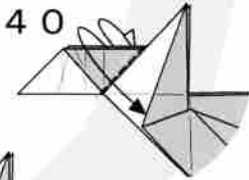

かぶせ折り

43

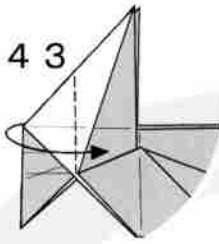

42

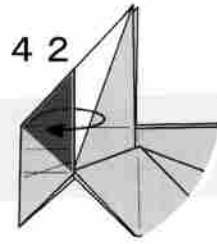

41

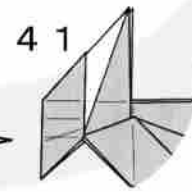

内側の紙を引き出す

44

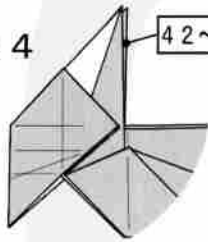

42~43

反対側も42~43と同様に折る

48

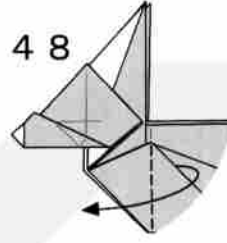

49

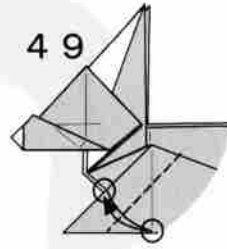

○同士を合わせて折り筋をつける

45

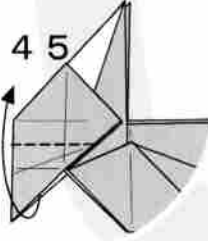

かぶせ折り

47

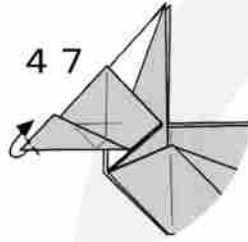

かぶせ折り

46

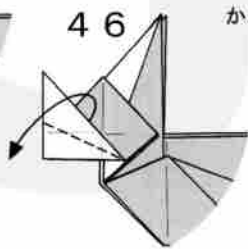

かぶせ折り

50

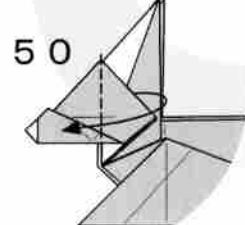

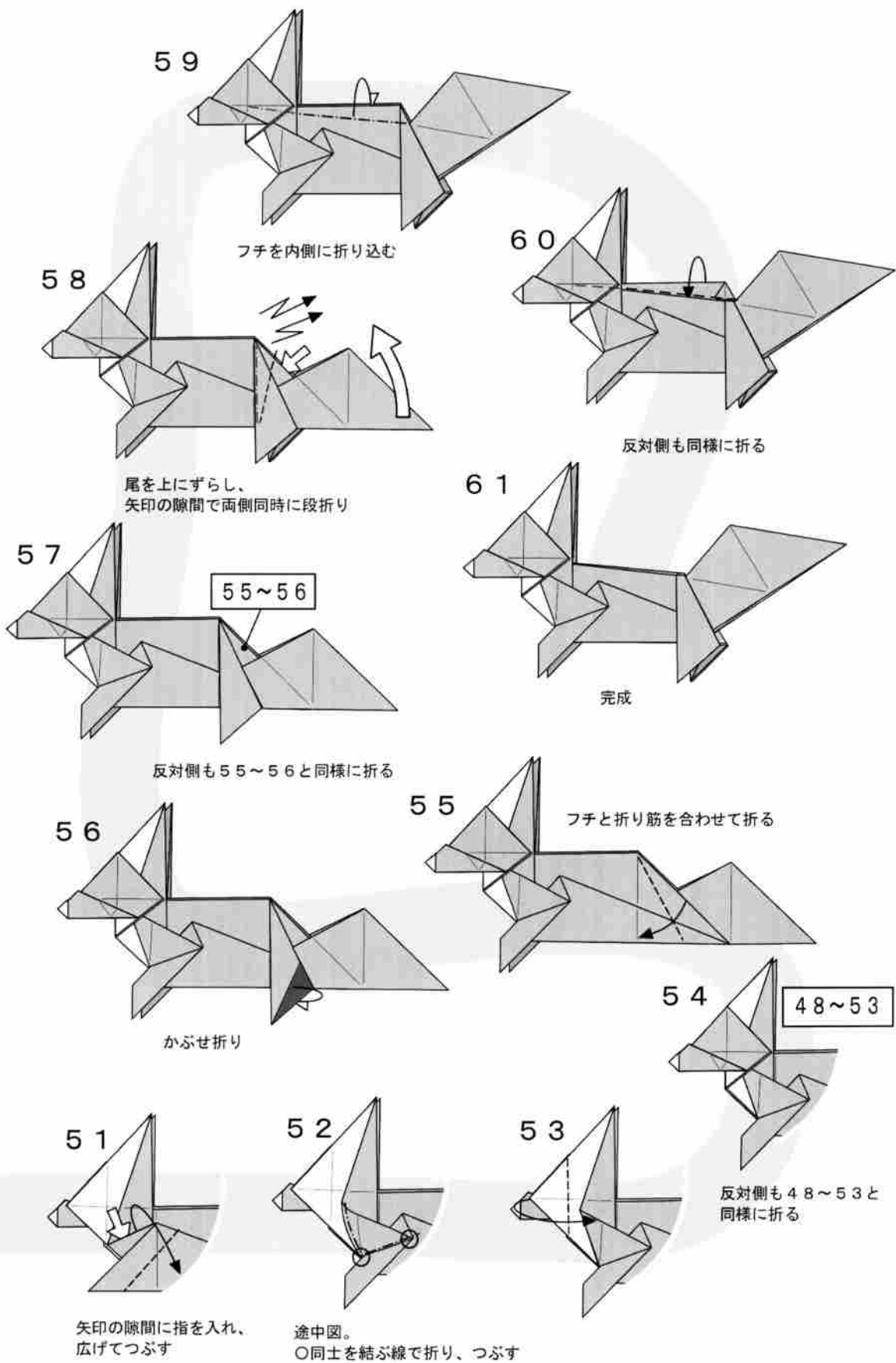

# 고양이 Cat

by Yoo TaeYong : Korea  
Diagram by Yoo TaeYong

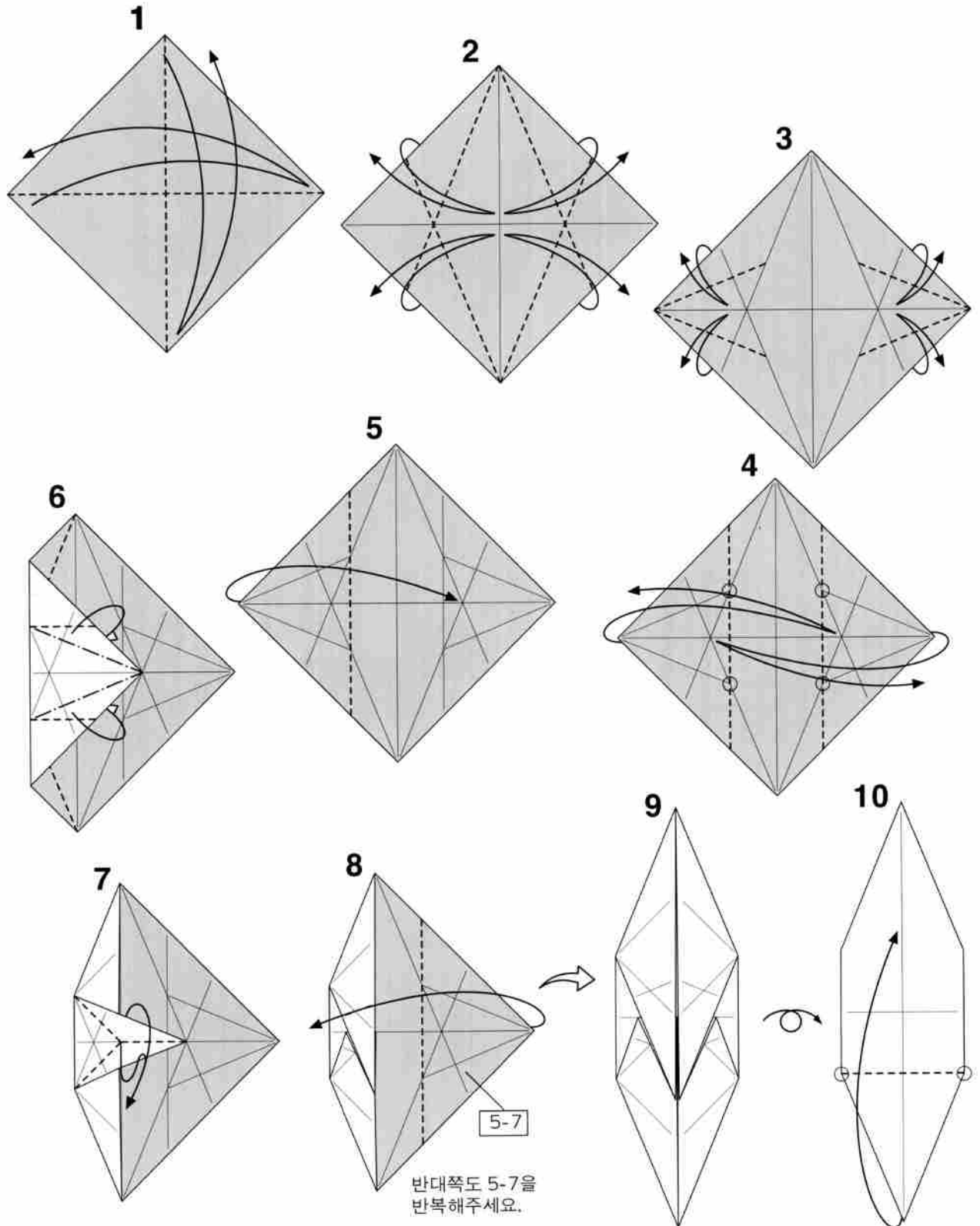
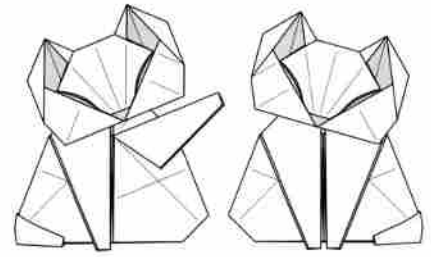

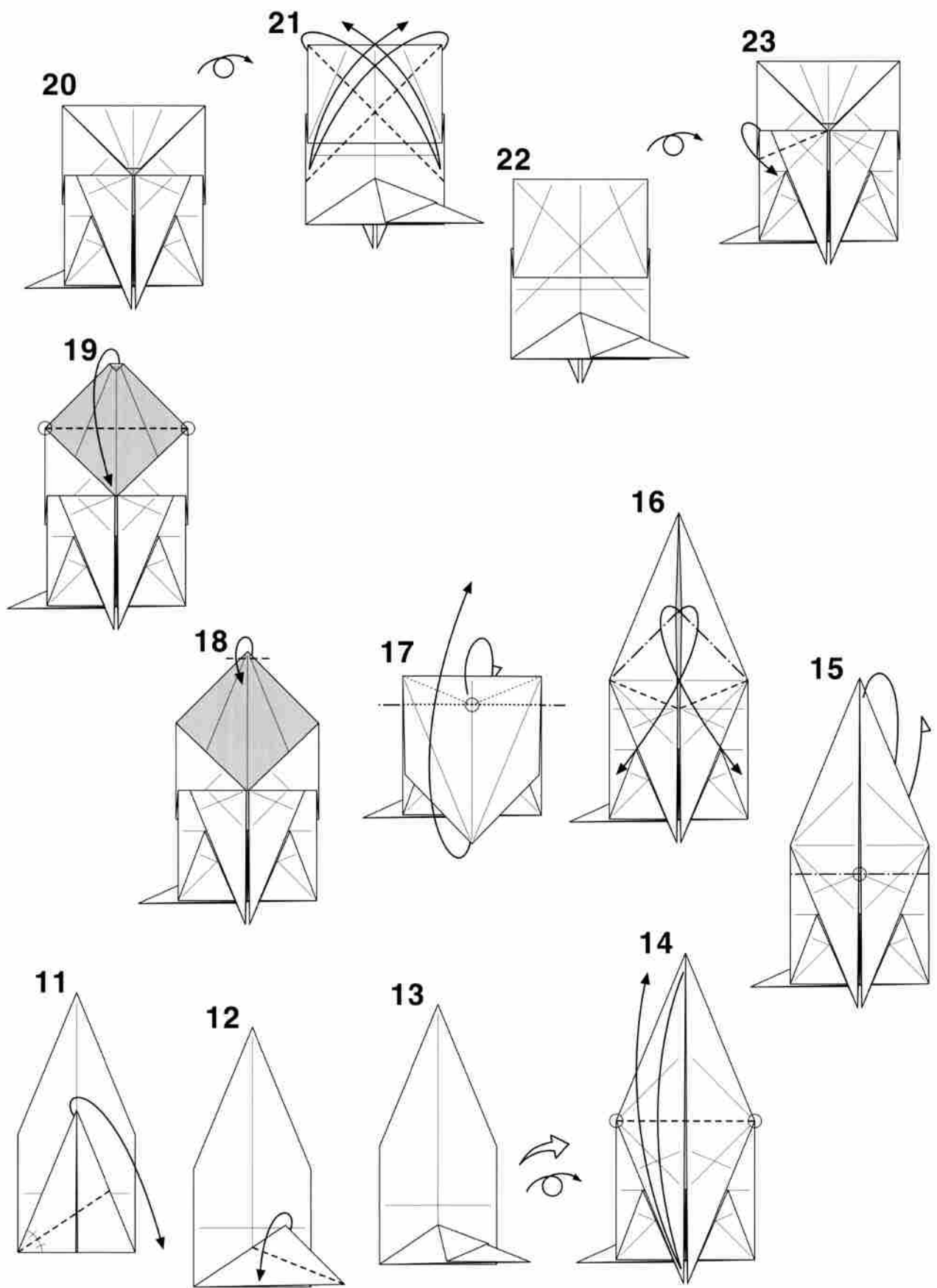

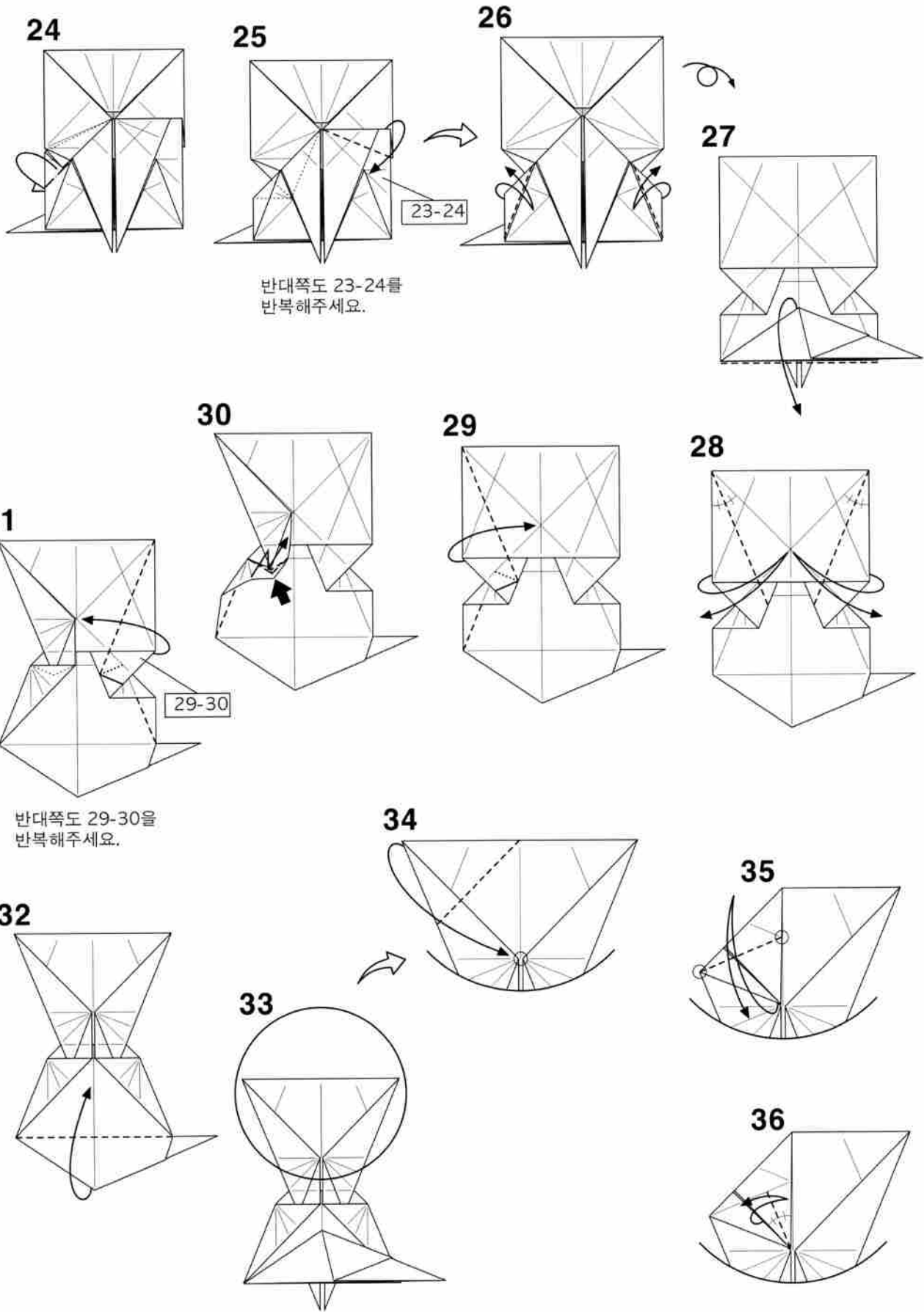

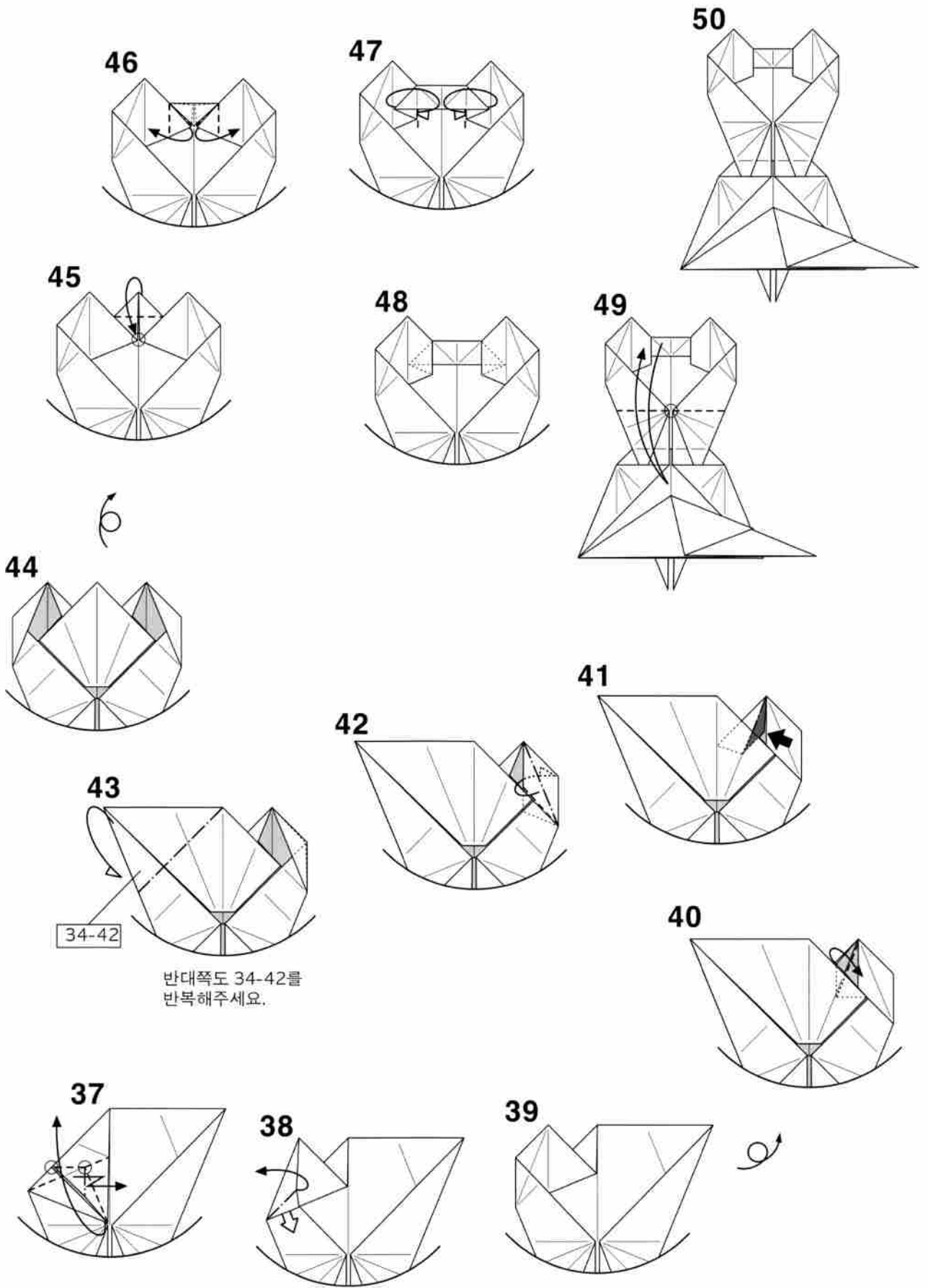

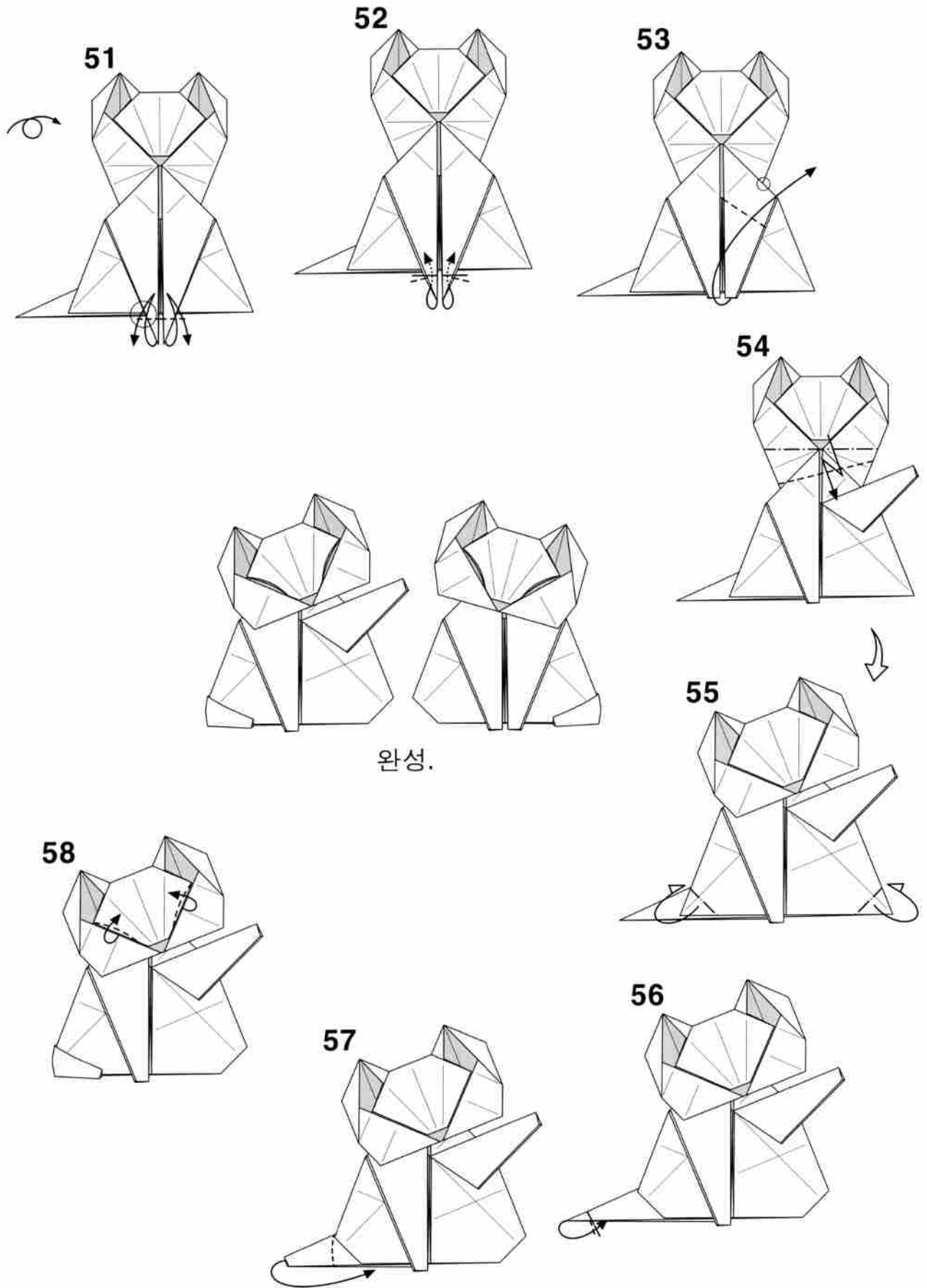



# 말벌 Wasp

by Hashimoto Haruka : Japan

Diagram by Hashimoto Haruka

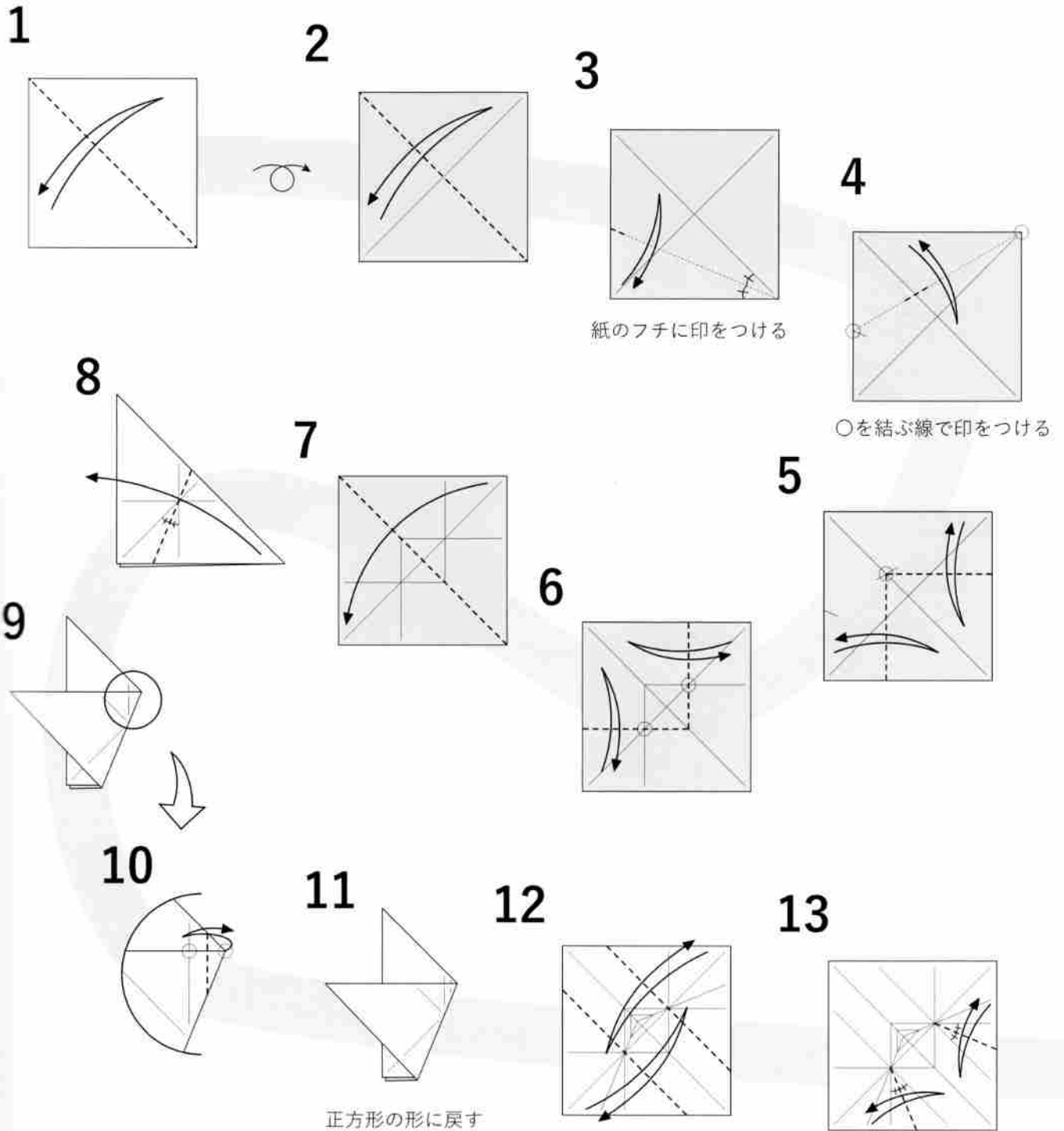
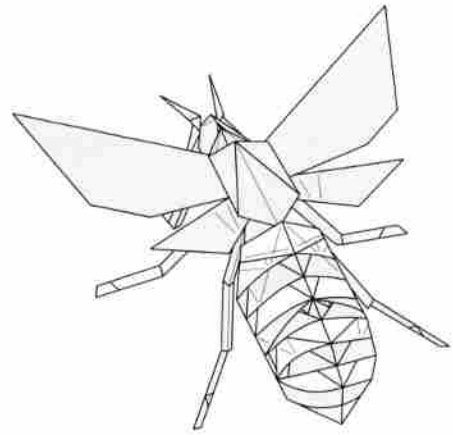

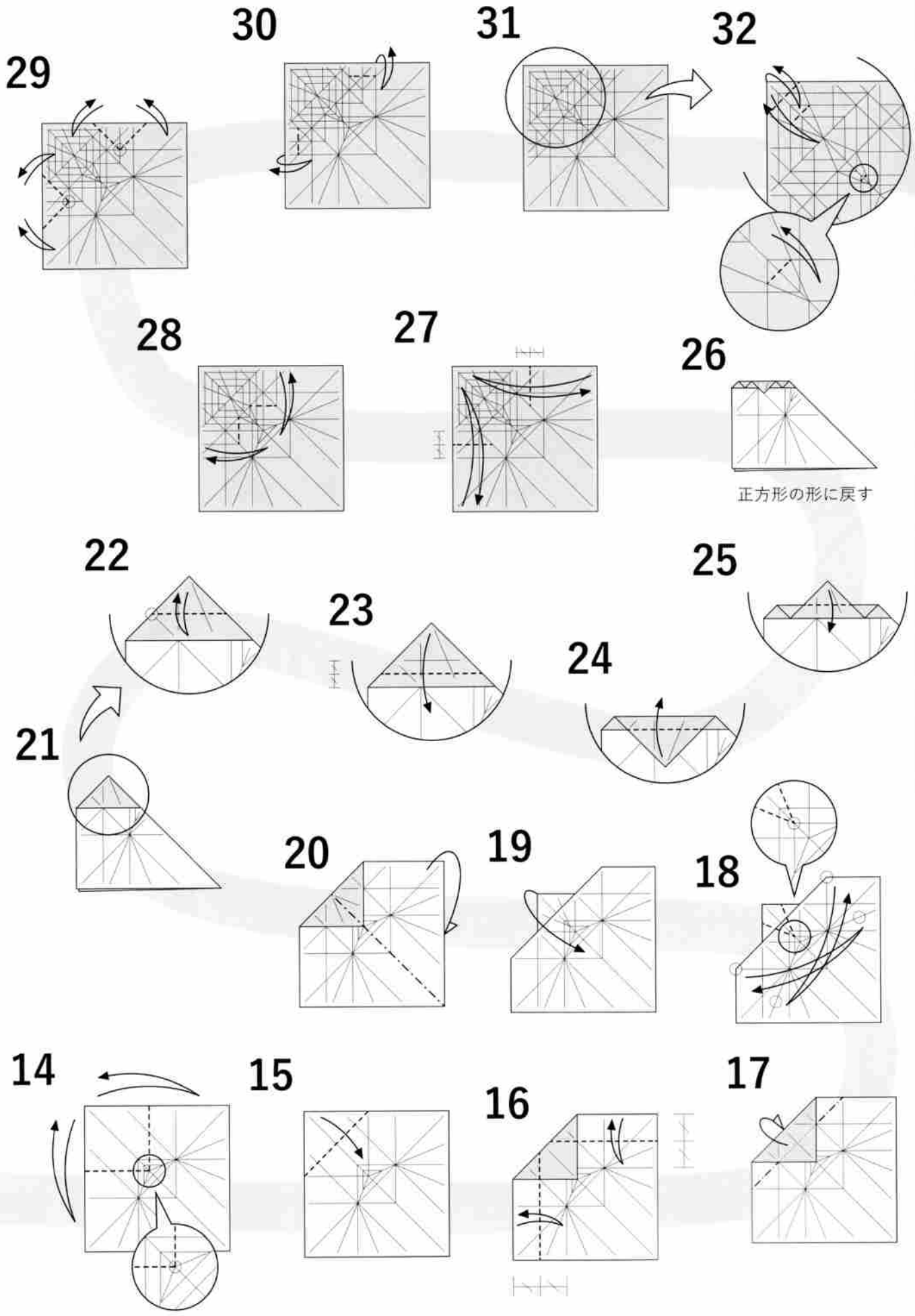

33

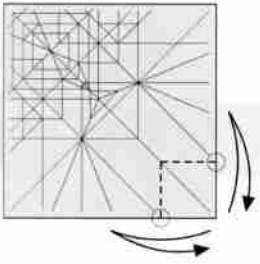

34

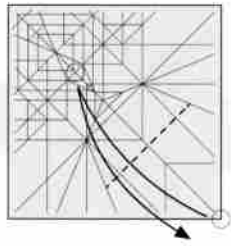

35

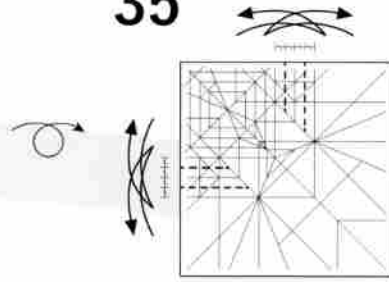

36

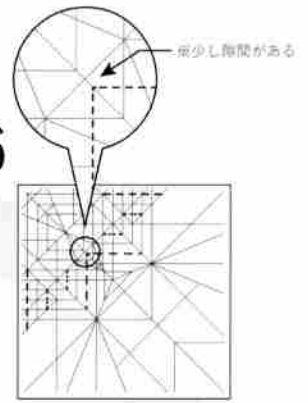

図の通り折り筋を付ける

39

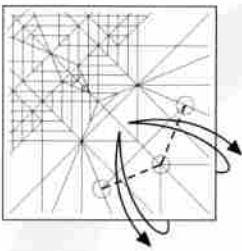

38

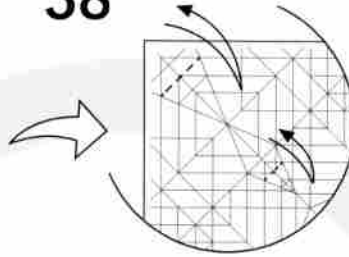

37

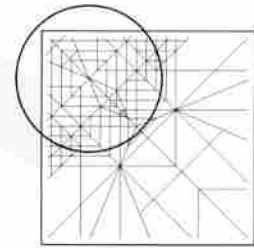

40

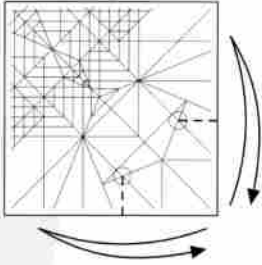

44

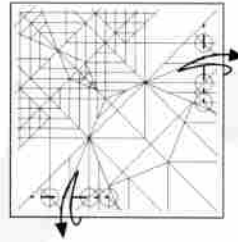

45

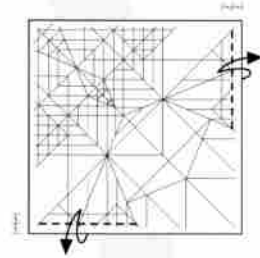

41

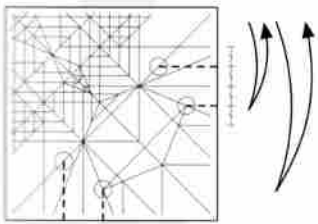

43

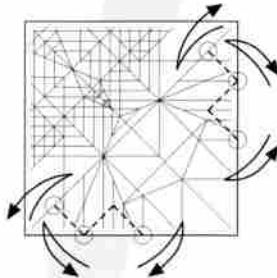

46

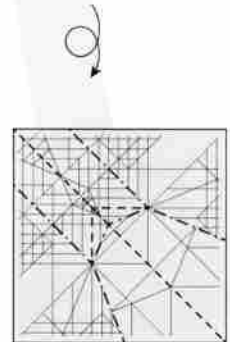

図の折り線の通り折り畳む

42

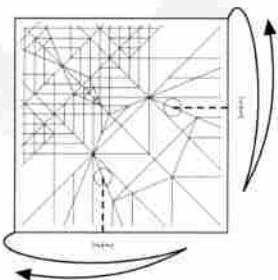

57



58

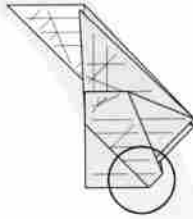

61

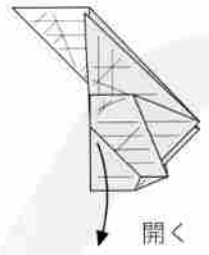

56

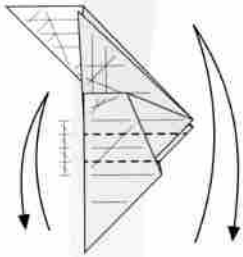

60

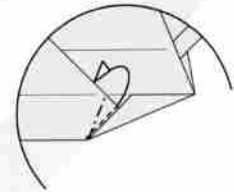

59

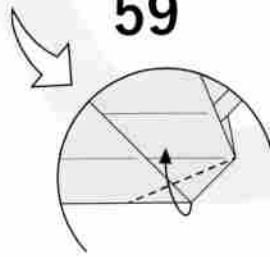

内側に引き寄せるように折る

55



52

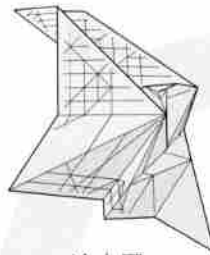

51

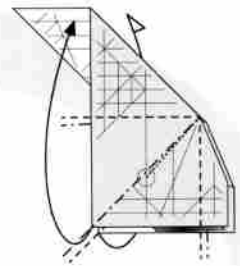

上の紙を引き寄せながら内側についてる折り筋に沿ってかぶせ折りをするように折り畳む

54

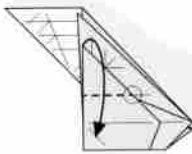

53

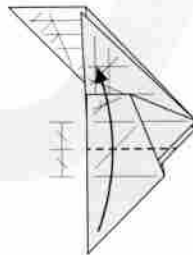

50

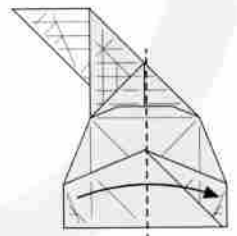

47

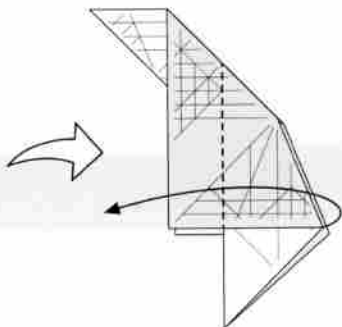

48

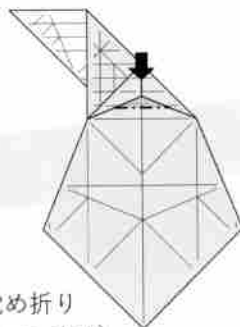

沈め折り (open sink)

49

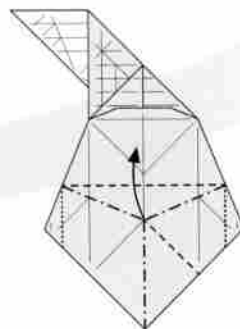

62



63

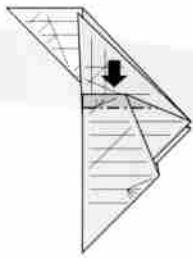

沈め折り  
(open sink)

64

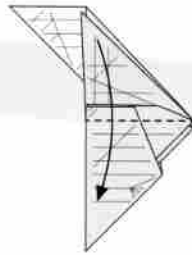

65

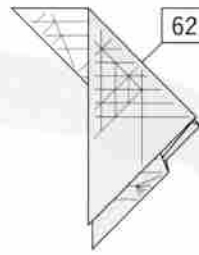

反対側も 62-64 と同様に折る

66

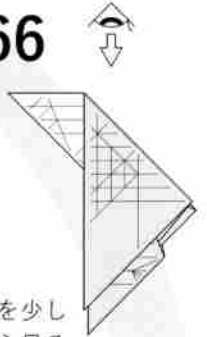

次の図は紙を少し  
開いて上から見る

69

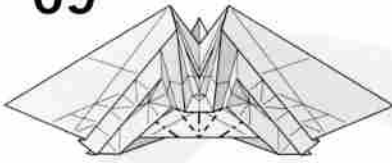

途中図 3  
紙を重ねたまま折る

68

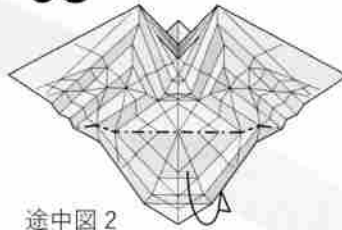

途中図 2

67

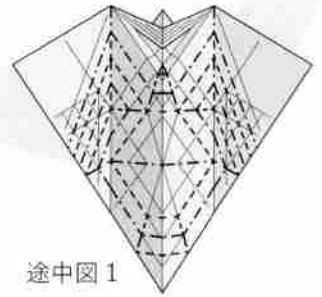

途中図 1

70

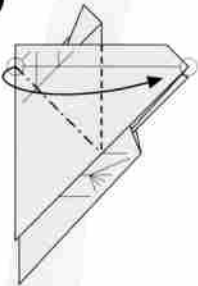

開いてつぶすように折る

74

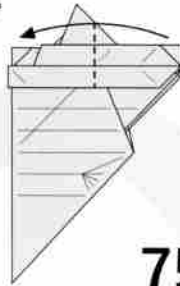

71

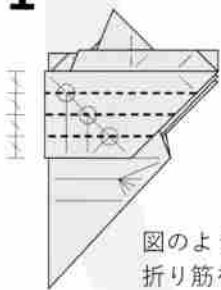

図のように 4 等分に  
折り筋を付ける

73

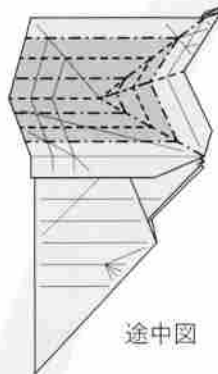

途中図

75

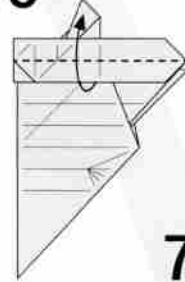

72

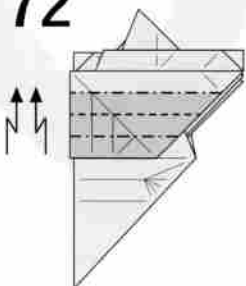

段折りのように沈めて折る

76

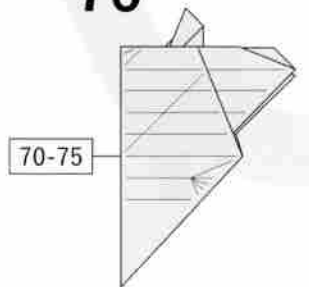

反対側も 70-75 と同様に折る

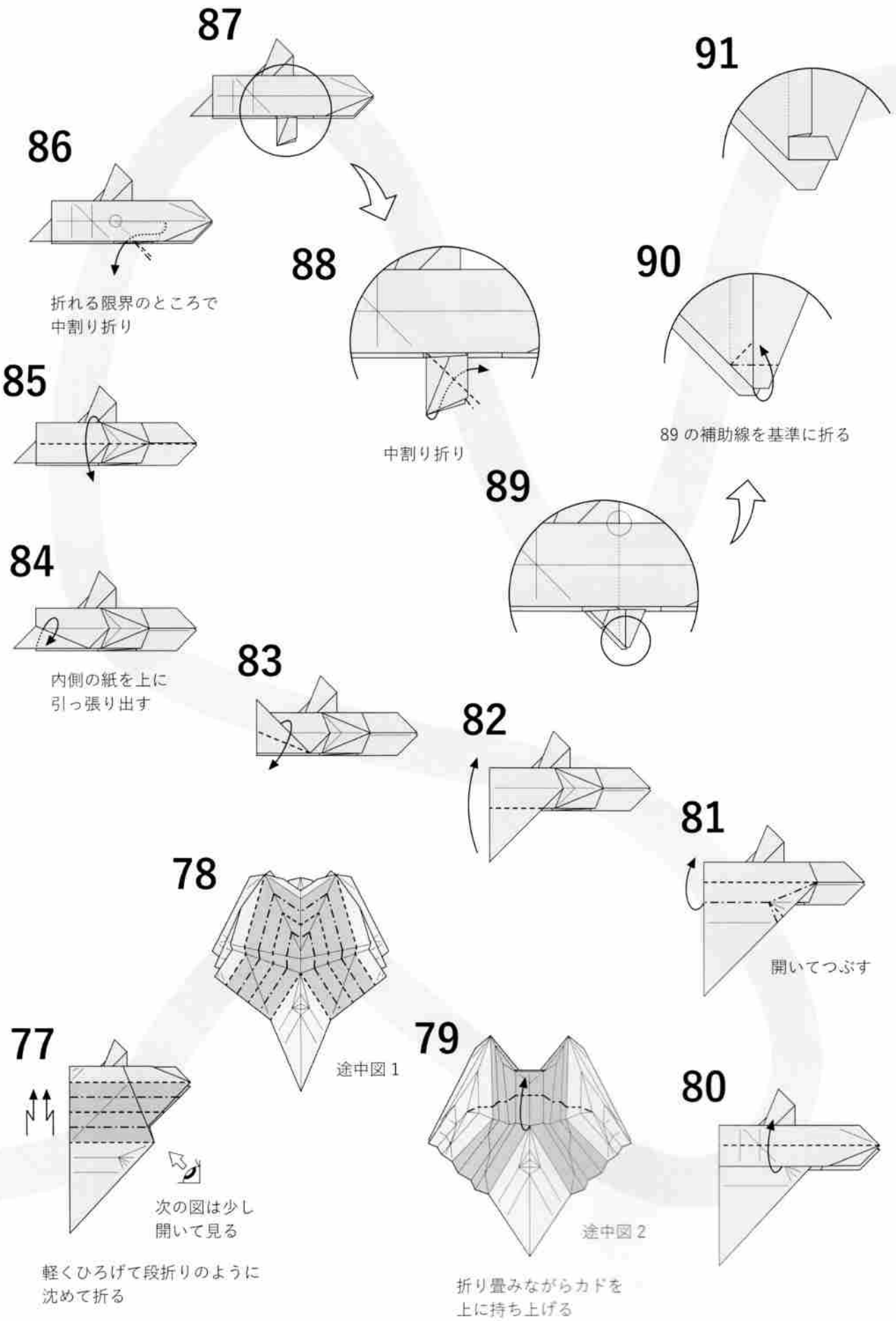

92

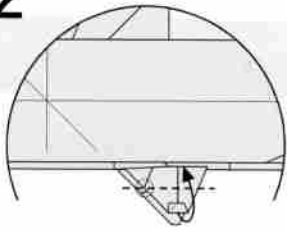

93

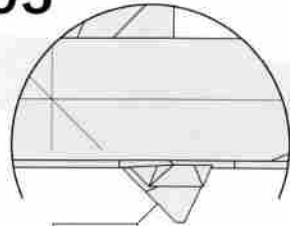

90-92

反対側も 90-92 と同様に折る

94

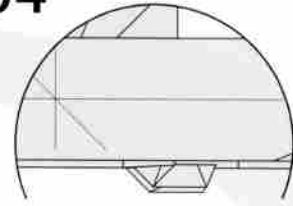

95

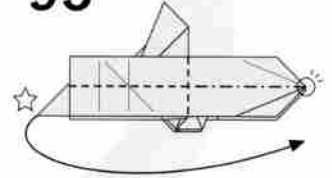

紙を開きながら☆を反対側に持っていく

97

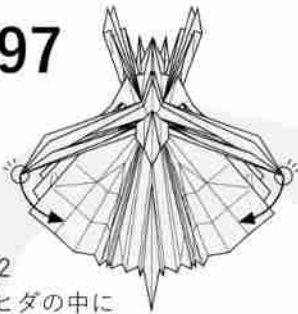

途中図 2  
カドをヒダの中に入れて折り畳む ☆

96



途中図 1

次の図は別の視点から見る

98



ヒダを開いてつぶすように折る

104

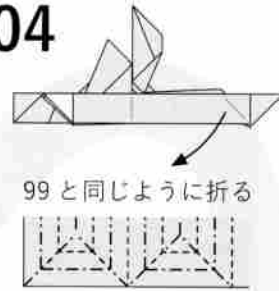

99 と同じように折る

平面図

99

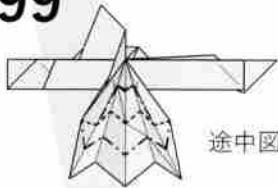

途中図



平面図

103

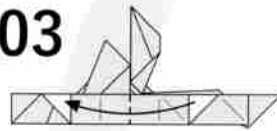

102

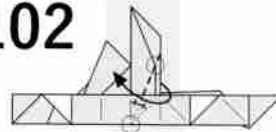

105

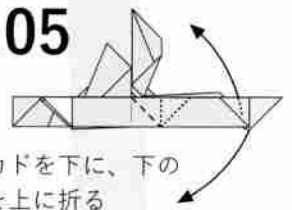

上のカドを下に、下のカドを上折る

101

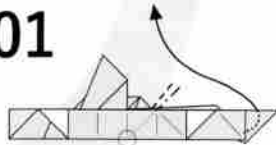

内側に入っているカドを中割り折りする

106

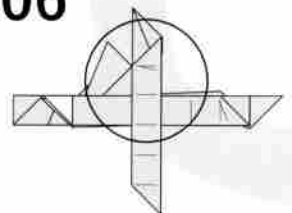

100

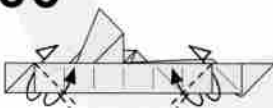

かぶせ折り  
(※紙を破かないように注意)

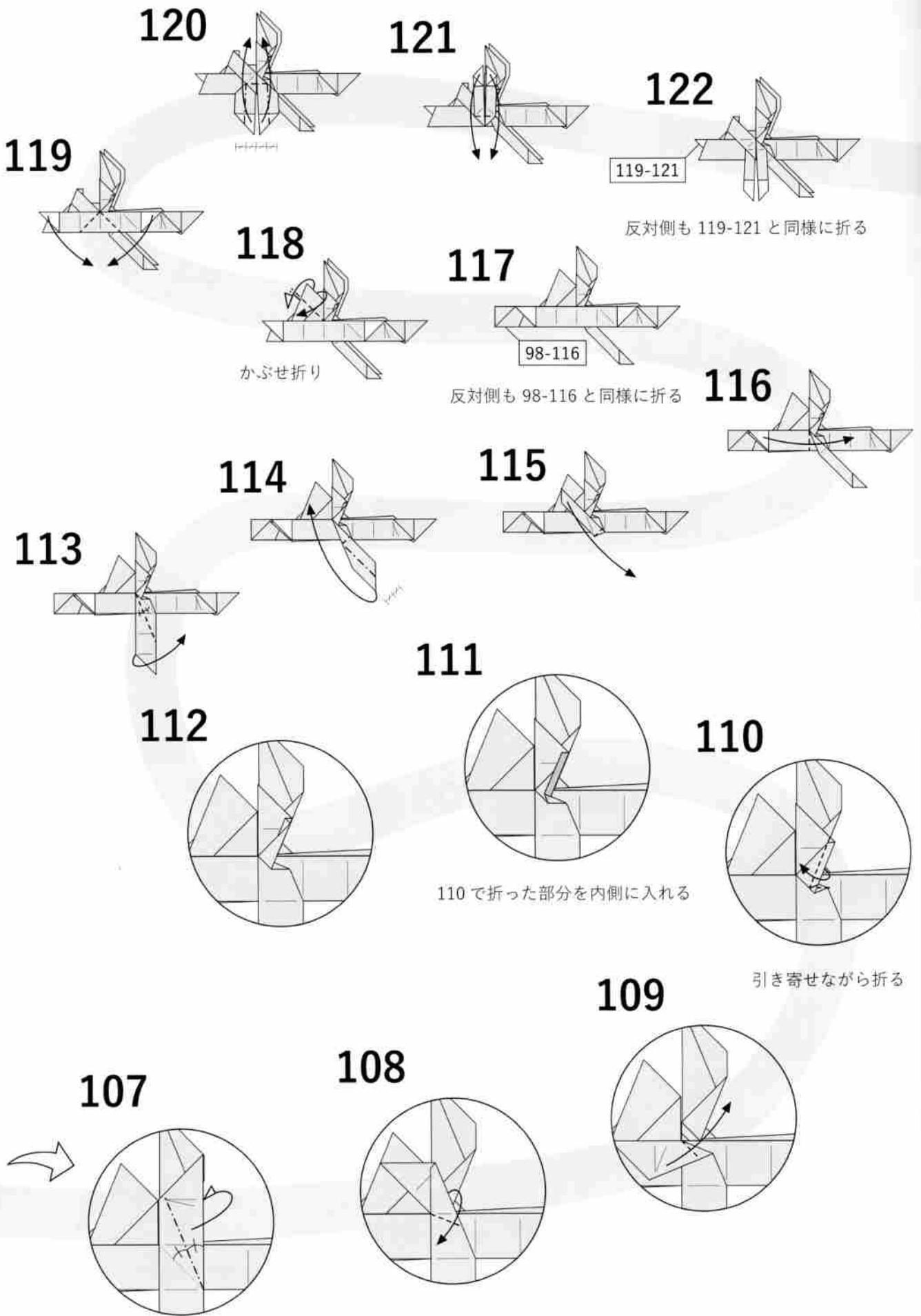



123

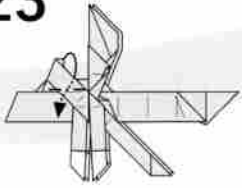

内側に入れる

124

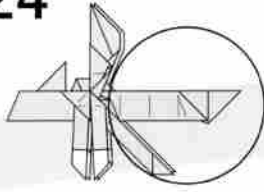

125



ヒダをまとめて折る

126

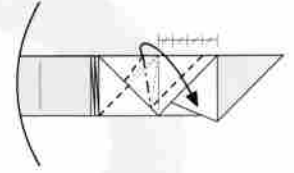

128

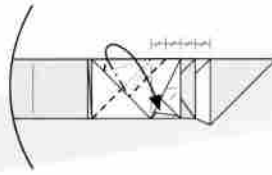

127

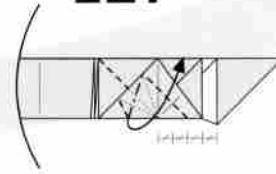

129

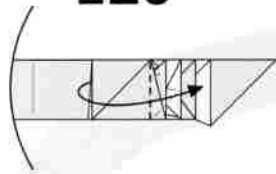

130

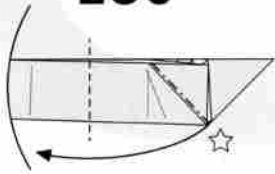

開いてつぶすように折る

131

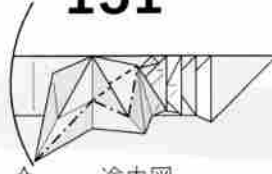

途中図

132

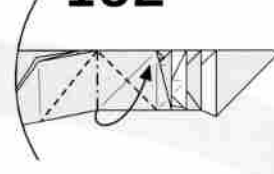

133

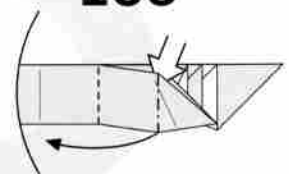

開いてつぶすように折る

135

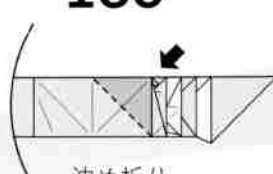

沈め折り  
(open sink)

134

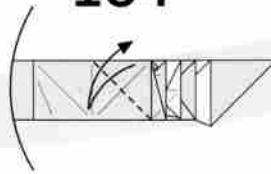

136

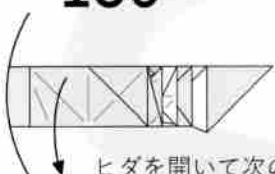

ヒダを開いて次の図を  
参考に折り畳む

137

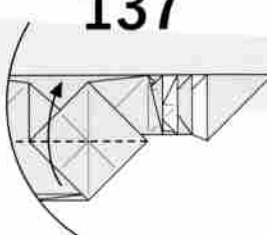

138

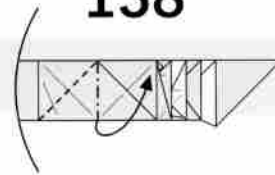

139

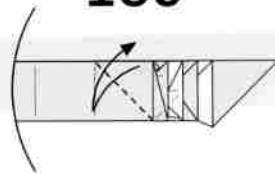

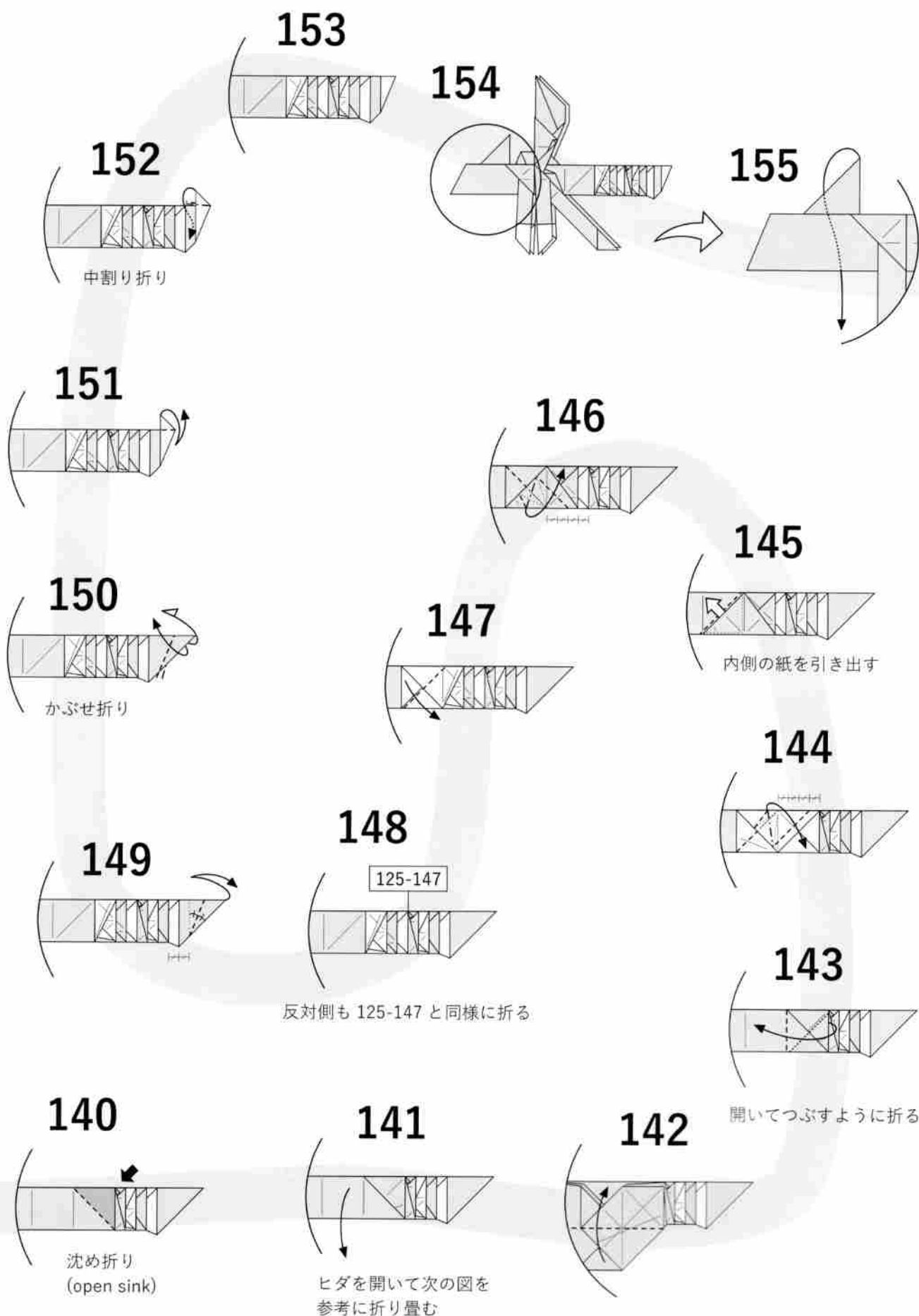

156

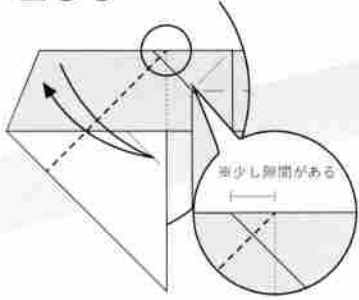

両側で折り筋を付ける

157

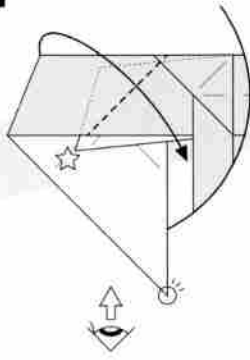

次の図は下から見る

158

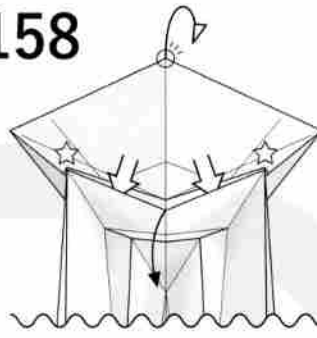

159

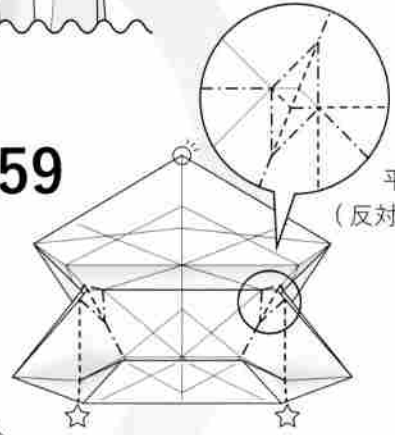

平面図  
(反対側も同様)

161

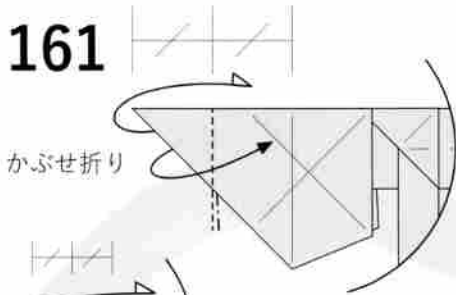

かぶせ折り

160

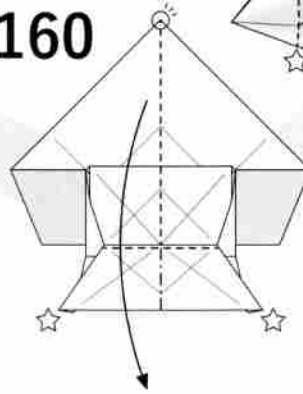

162

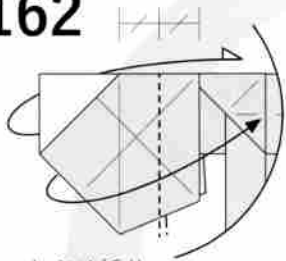

かぶせ折り

163

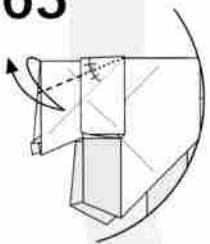

167

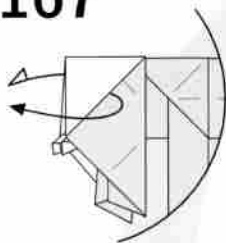

168

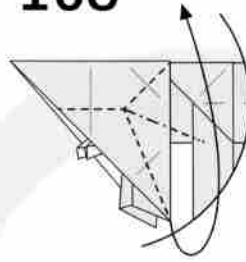

169

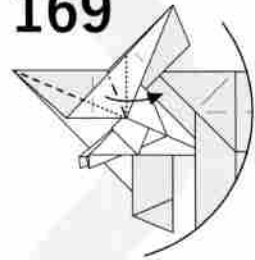

164

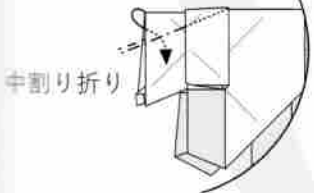

165

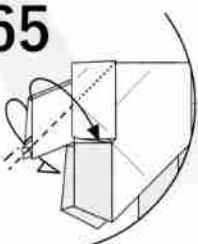

166

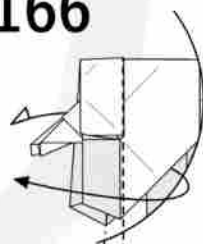

かぶせ折り

170

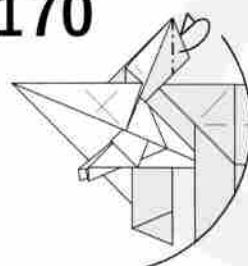

171

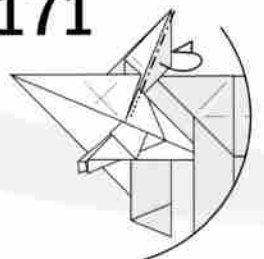

181

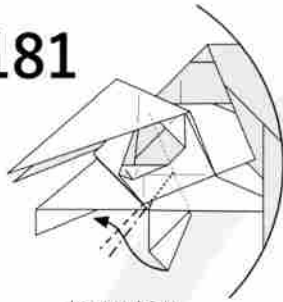

中割り折り

182

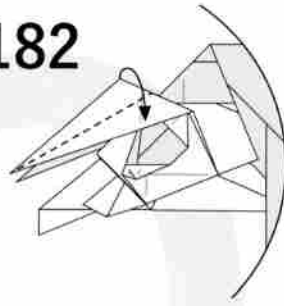

187

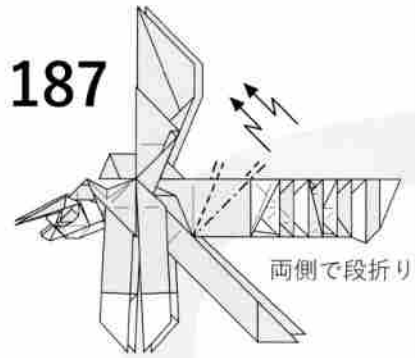

両側で段折り

180

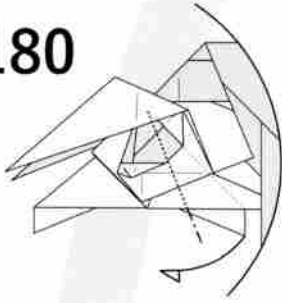

183

177-182



反対側も 177-182  
と同様に折る

186

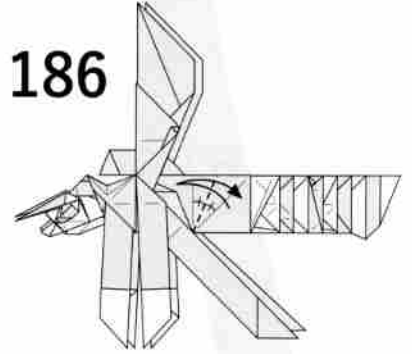

179

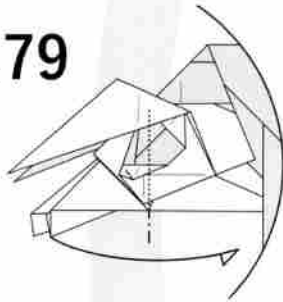

184

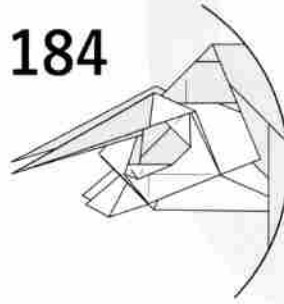

185

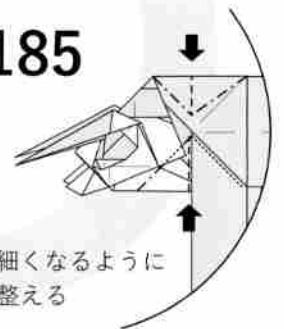

首が細くなるように  
形を整える

178



引き寄せながら折る

177



引き寄せながら折る

176

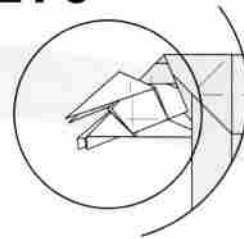

175

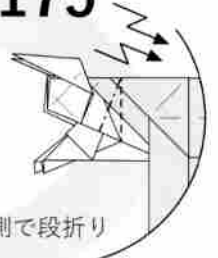

両側で段折り

172

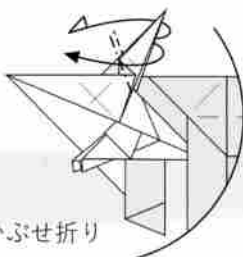

かぶせ折り

173

168-172

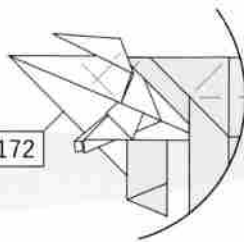

反対側も 168-172 と同様に折る

174

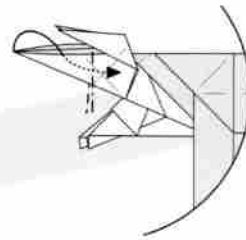

上のヒダの内側に折り込む

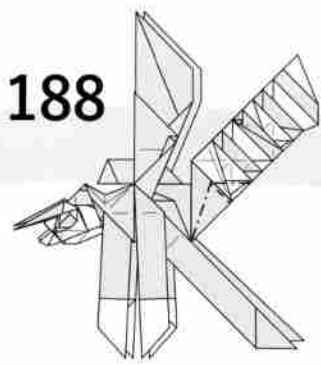

188

腹部に丸みが出るように立体的に折る

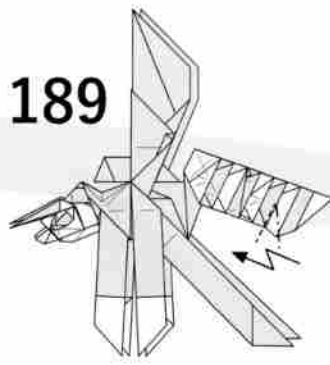

189

立体的になるように段折り  
反対側も同様に折る

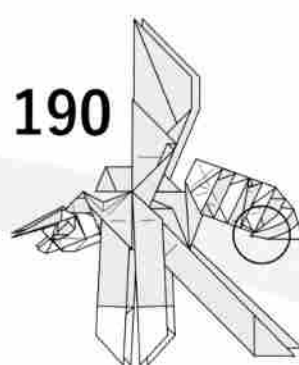

190

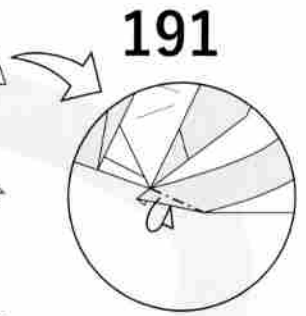

191

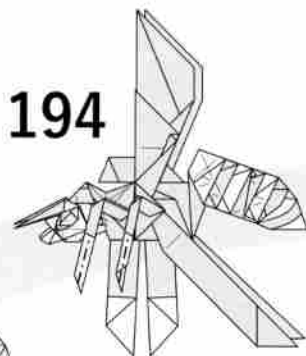

194

脚が細くなるように  
つまんで折る

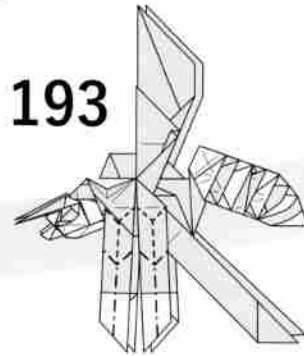

193

かぶせ折りをしながら  
脚の幅を半分にする

192

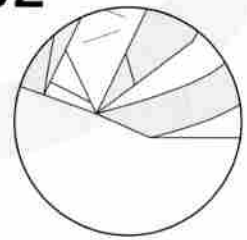

反対側も 191 と同様に折る

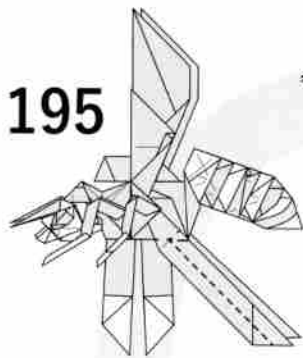

195

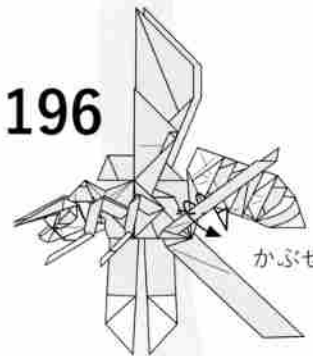

196

かぶせ折り

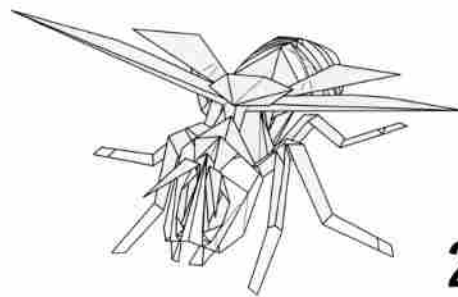

200

完成

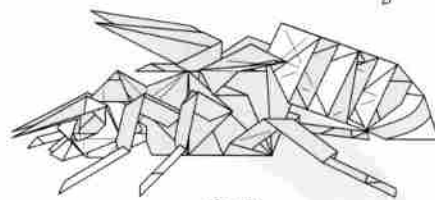

上から見た図

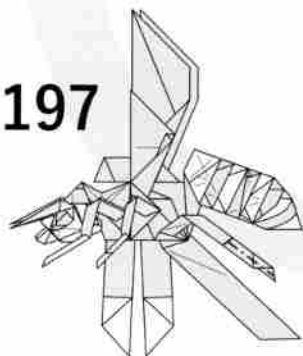

197

脚が細くなるように  
つまんで折る

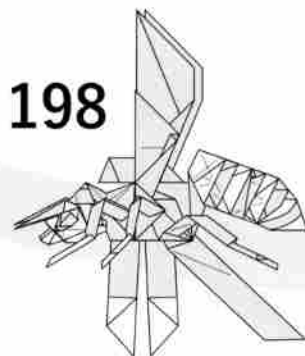

198

反対側も 193-197 と同様に折る

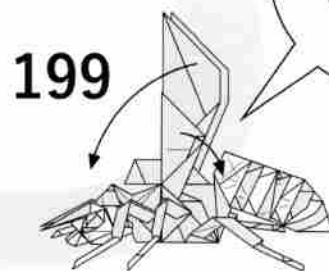

199

前翅と後翅を  
前後にずらして開く

# 피라냐 Piranha

by Kang HanUI : Korea  
Diagram by Kang HanUI

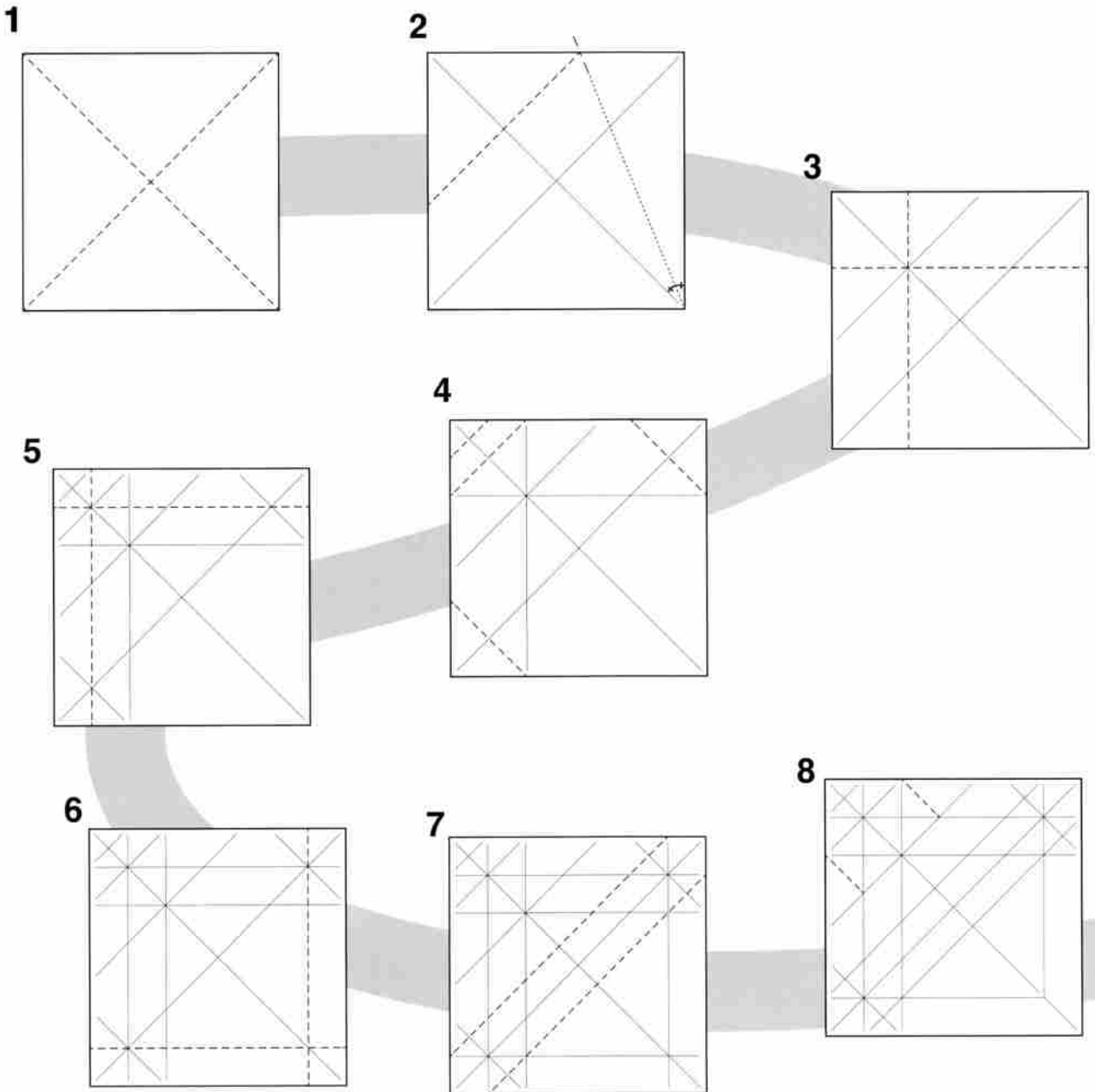
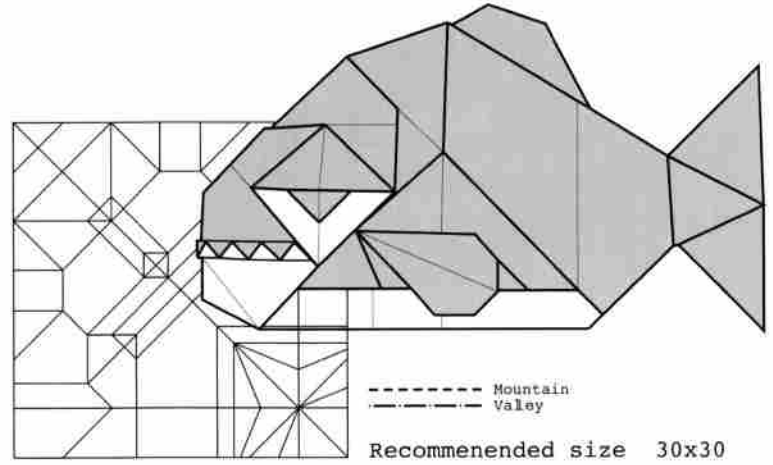

15

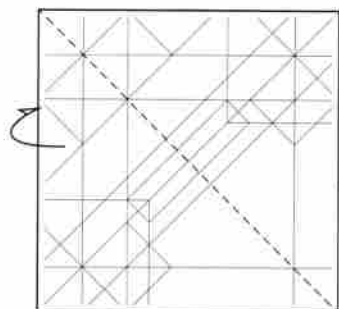

16

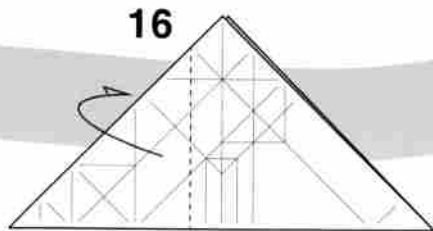

17

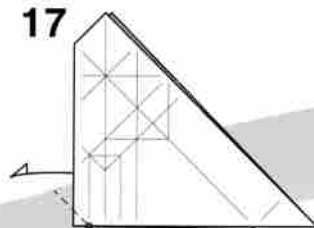

14

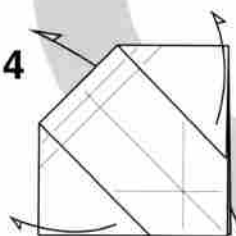

13

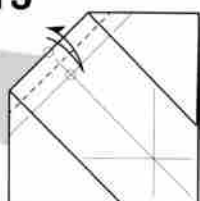

12

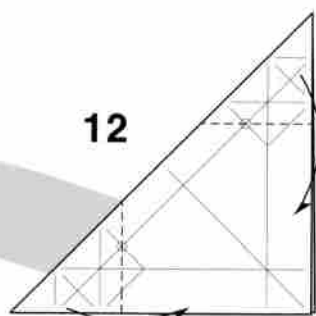

11

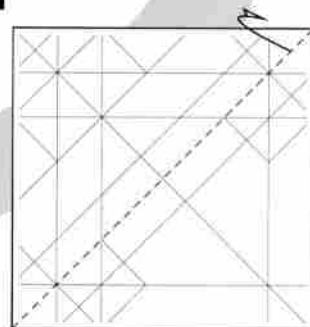

10

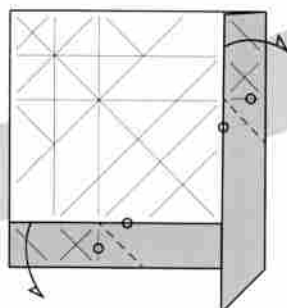

9

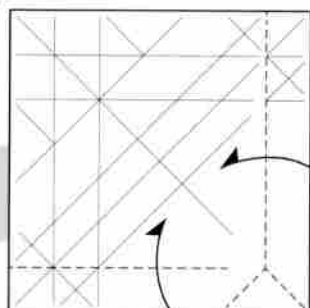

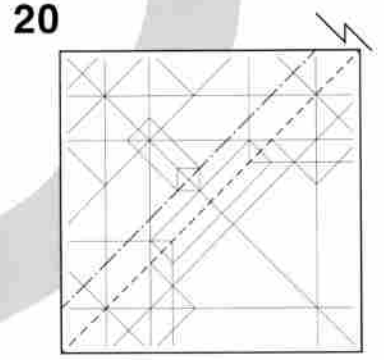
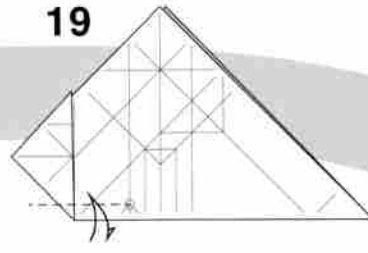
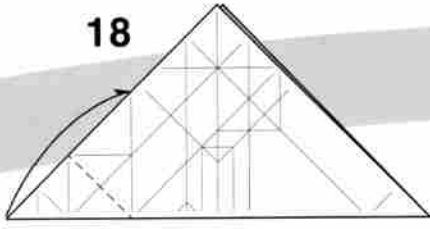

전부 펼치고 접은 선을 따라 계단접기하세요.

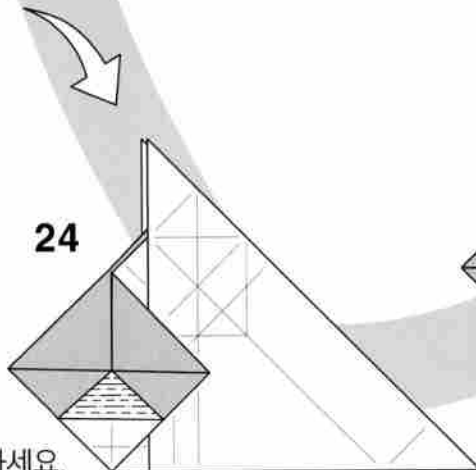
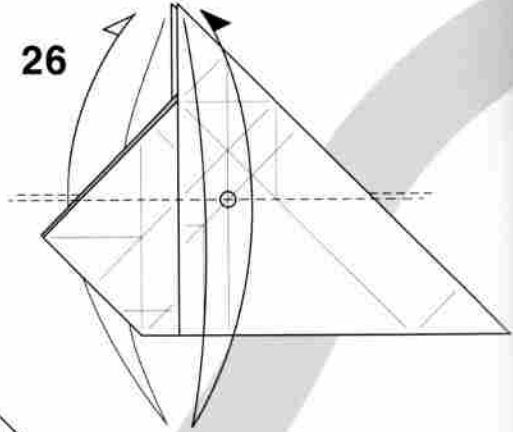
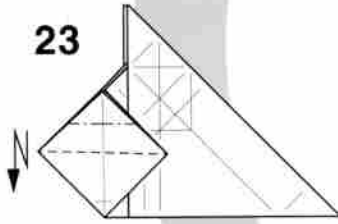
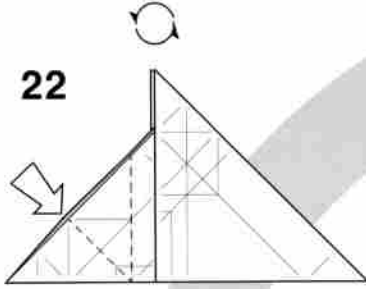
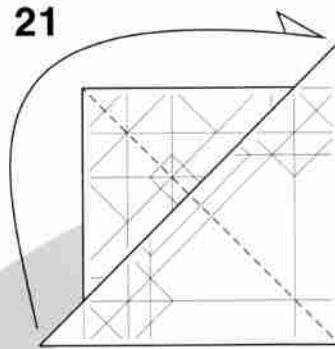

8 등분하세요.

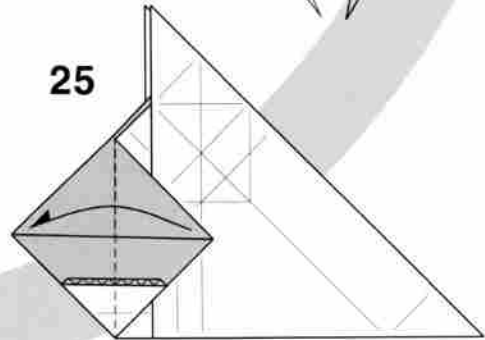



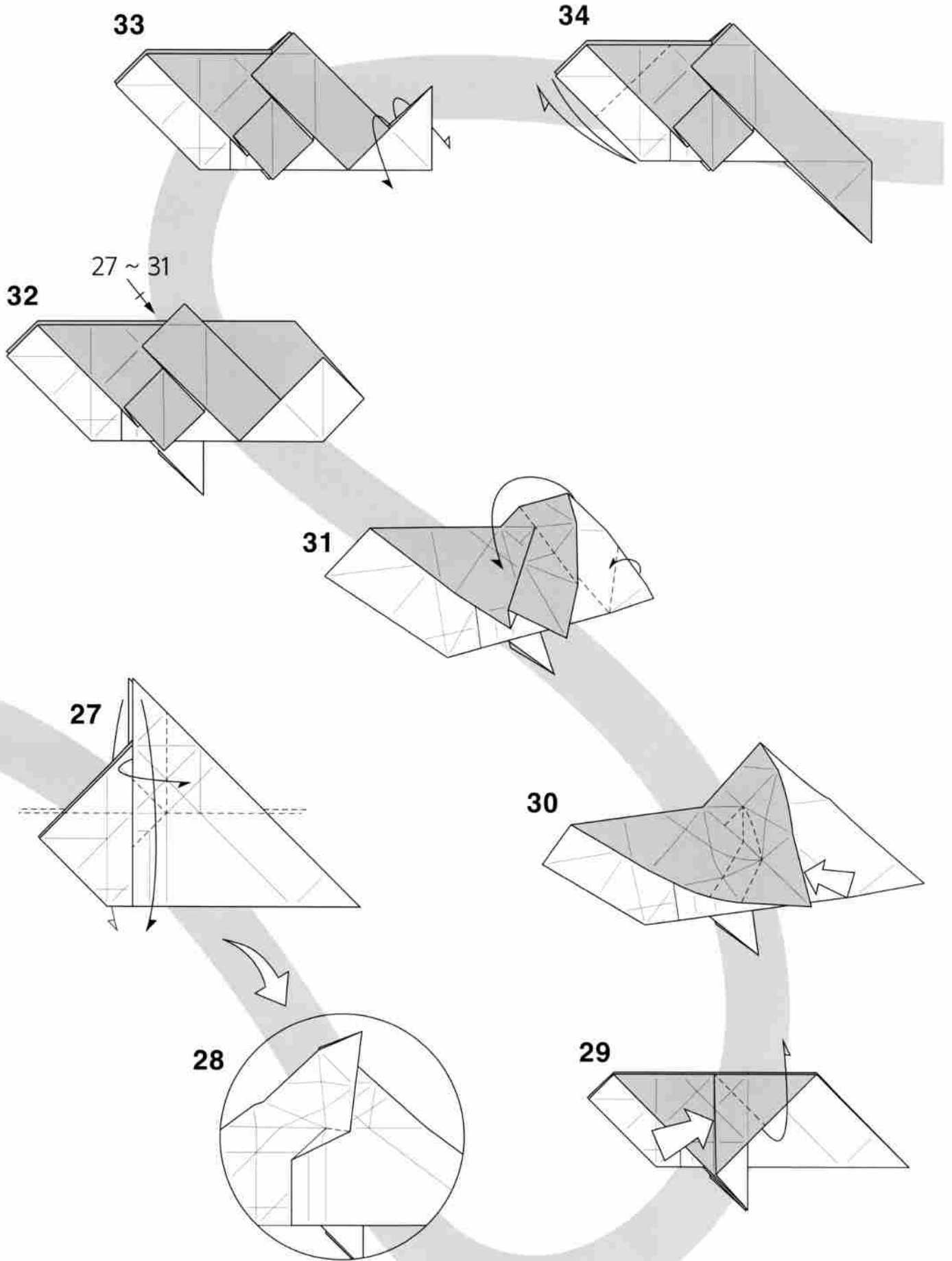

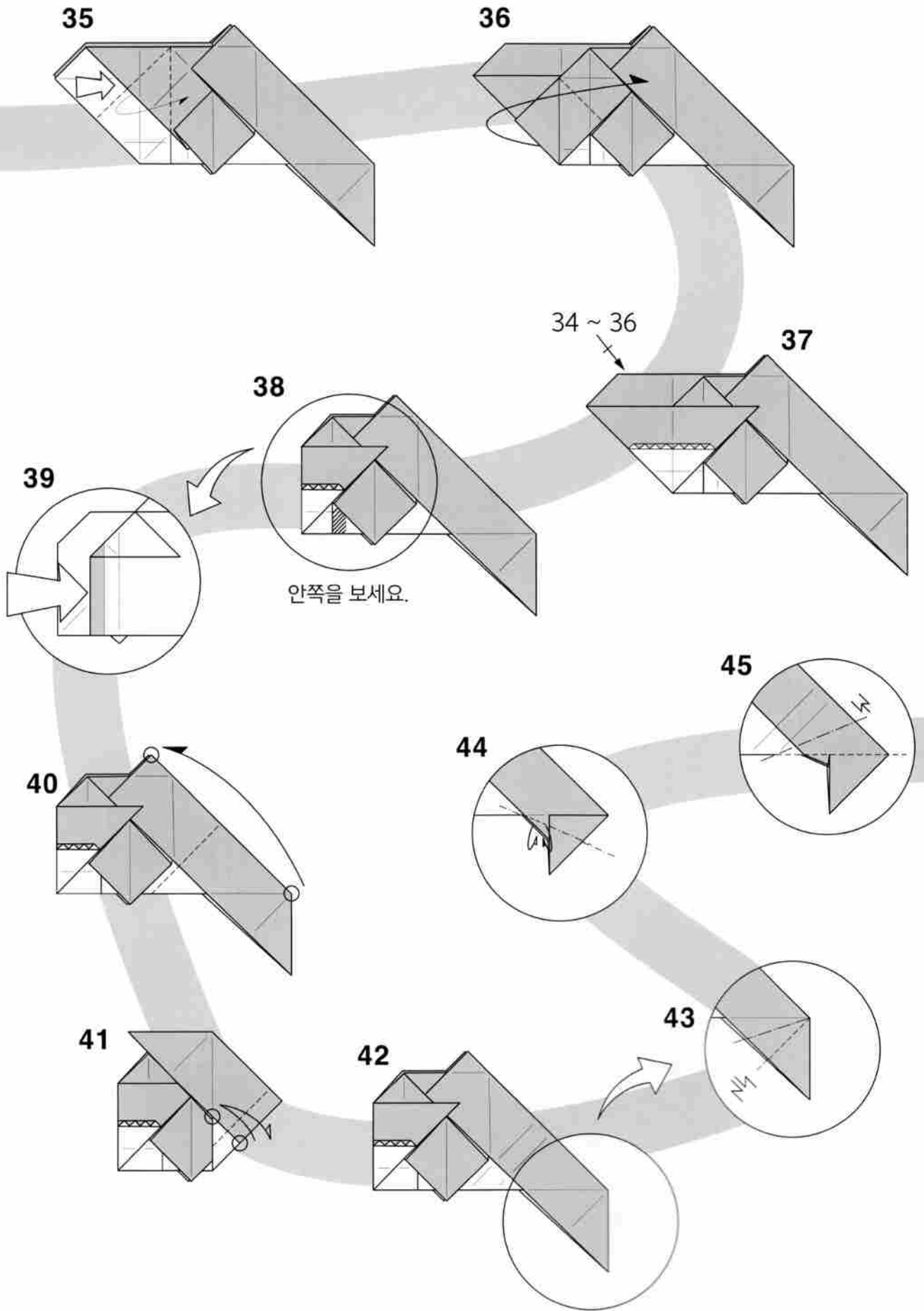

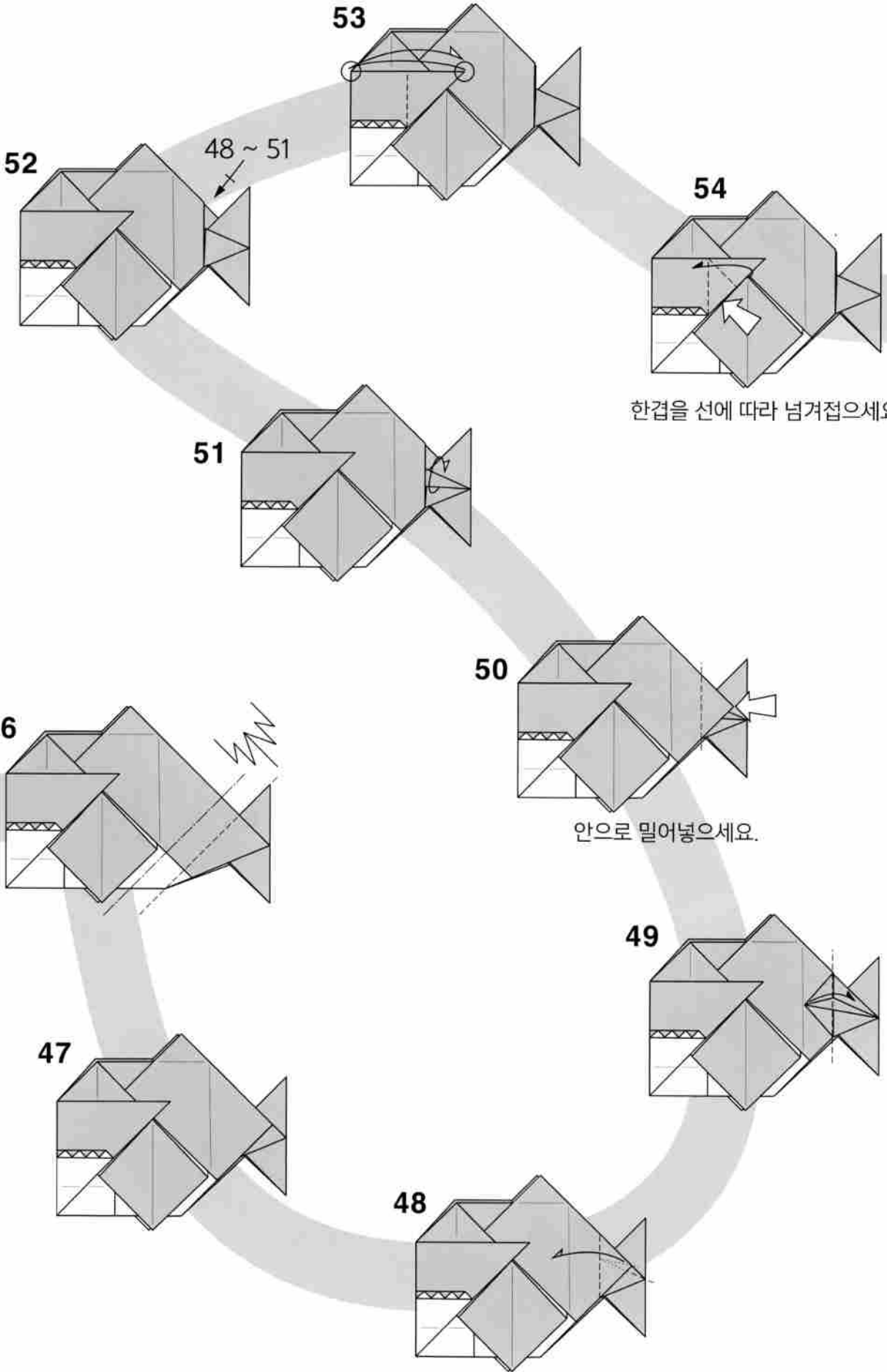

한겹을 선에 따라 넘겨접으세요.

안으로 밀어넣으세요.

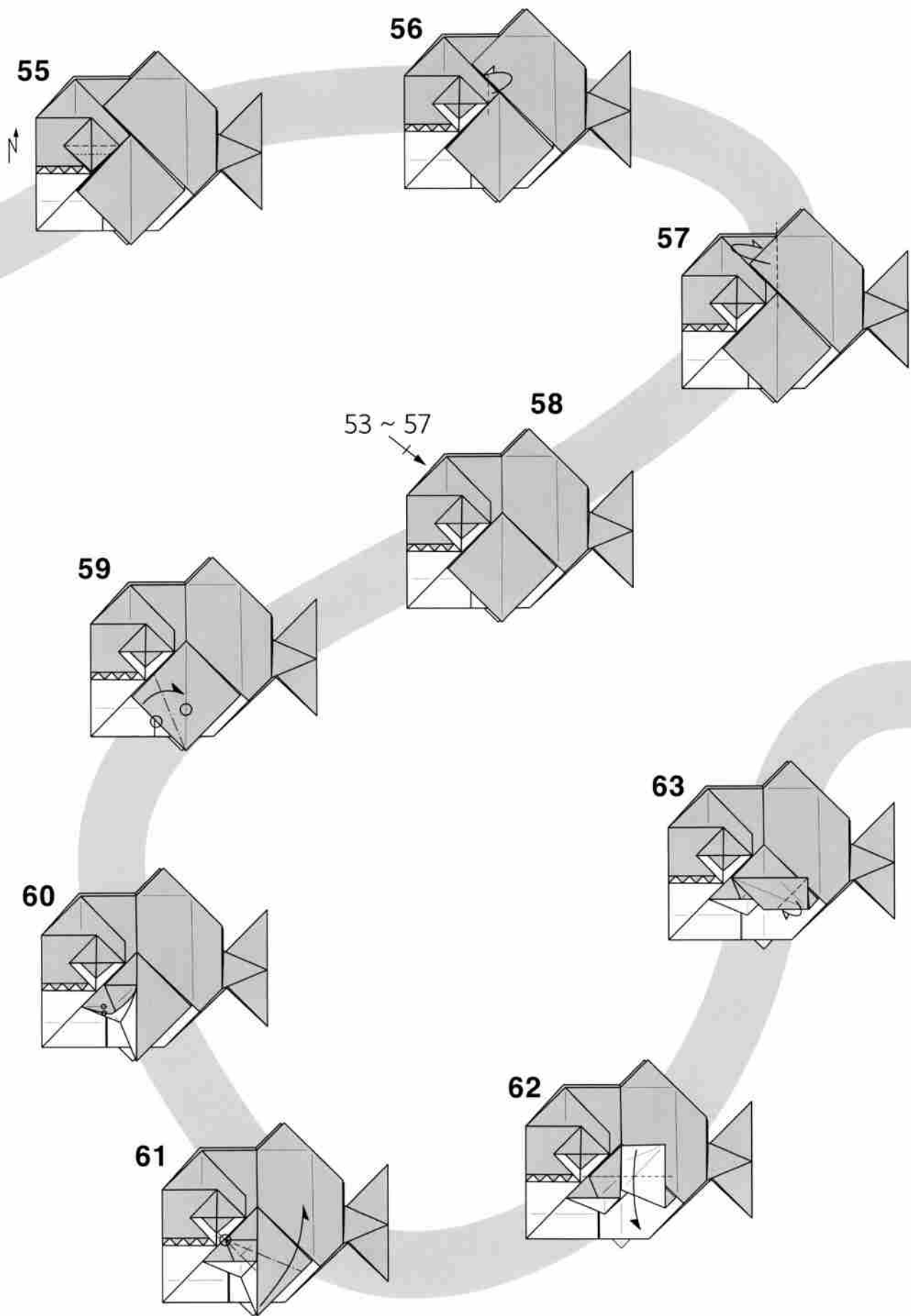

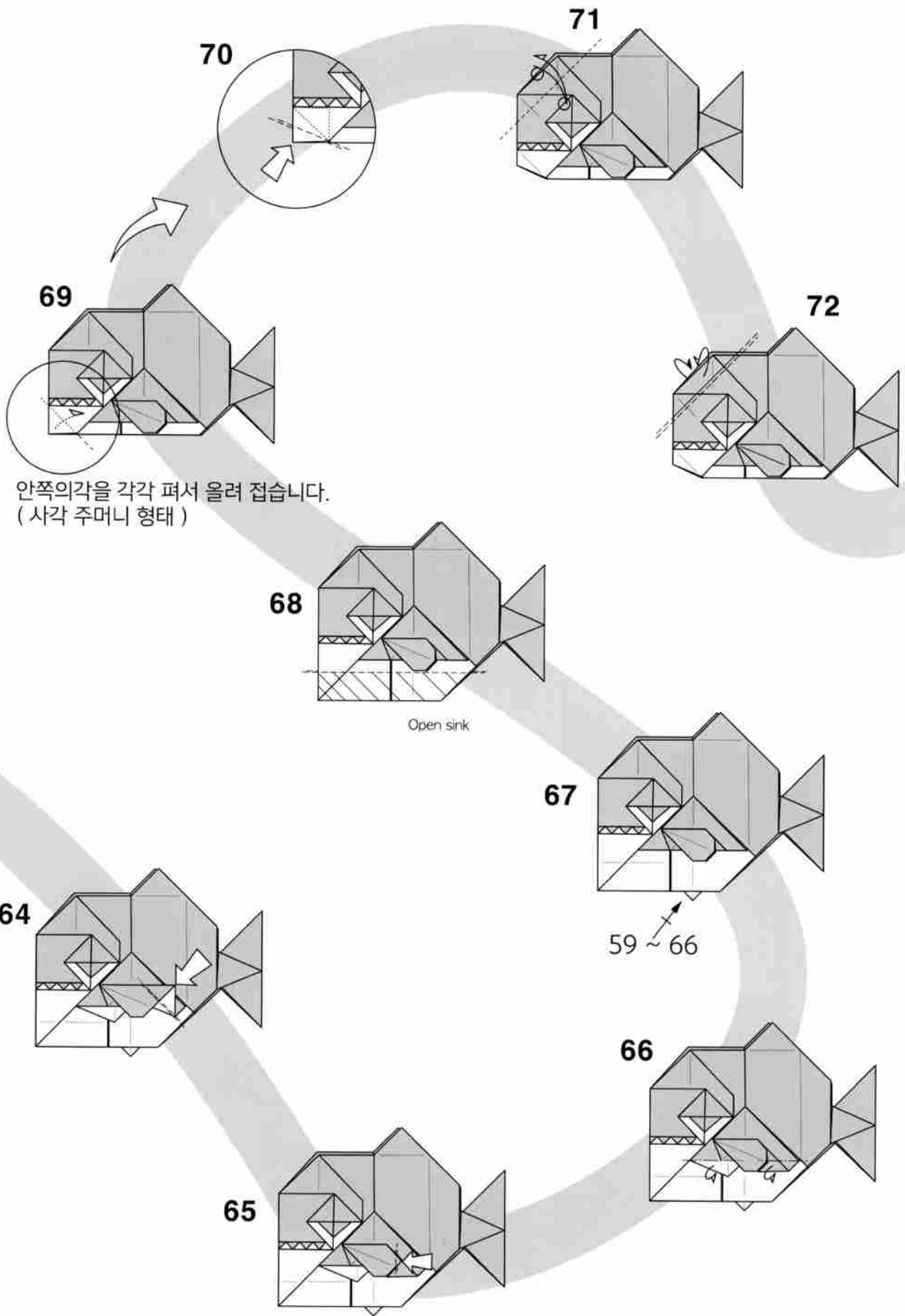

안쪽의각을 각각 펴서 올려 접습니다.  
(사각 주머니 형태)

Open sink

59 ~ 66

73

Close sink

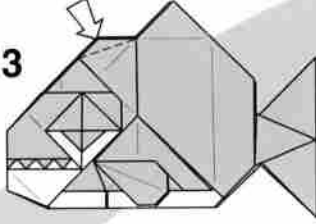

74

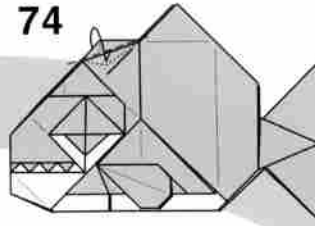

75

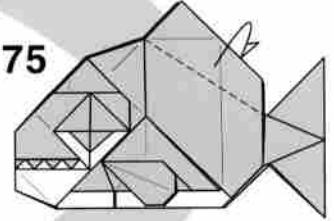

한쪽을 안쪽으로 넣어 접으세요.

76

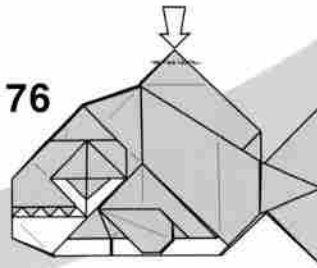

77

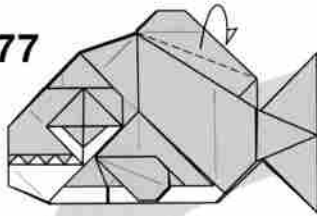

78

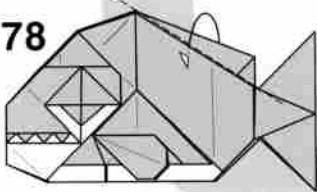

79

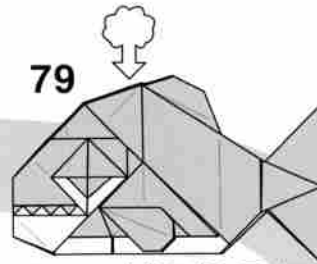

안쪽으로 볼륨감을 줍니다.

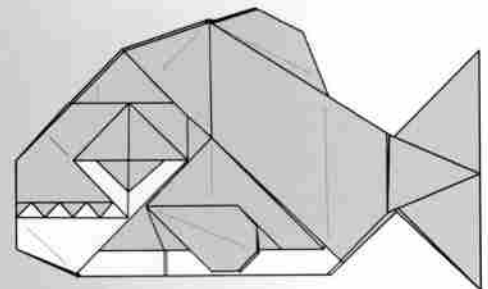

완성.

# 공작 Peacock

by Mindaugas Cesnavicius : Lithuania

Diagram by Mindaugas Cesnavicius

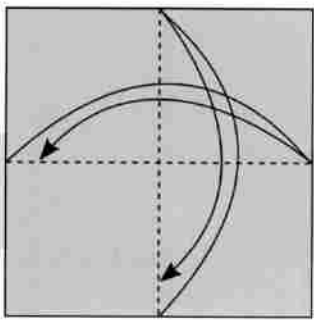
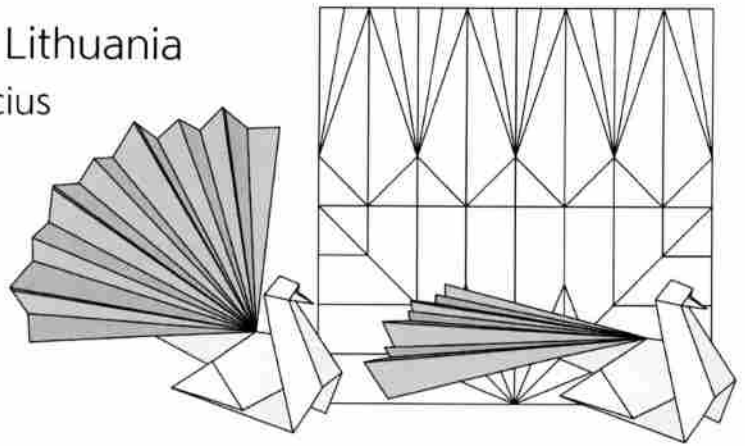

1. Start with color side up. Fold and unfold in half.

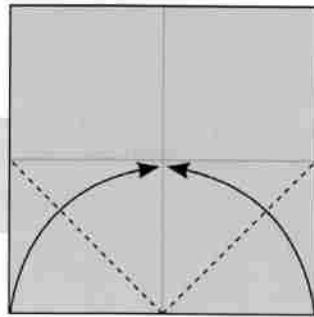

2. Fold corners to the center.

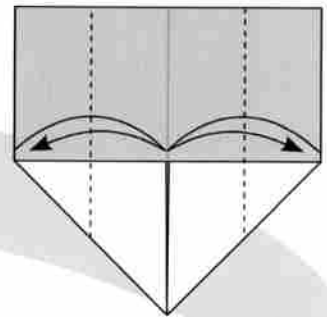

3. Fold and unfold in half.

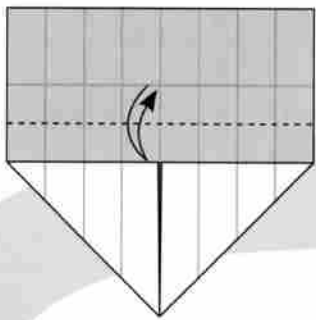

6. Fold and unfold in half.

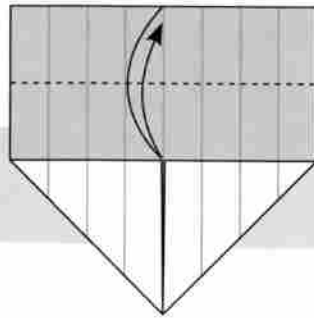

5. Fold and unfold in half.

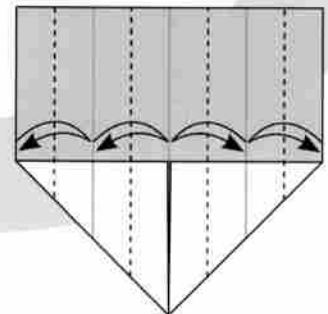

4. Fold and unfold in halves.

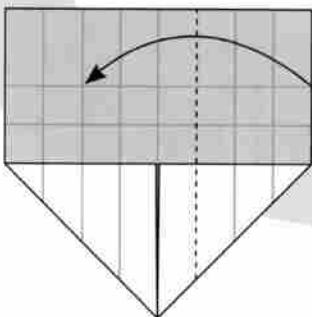

7. Fold to the left.

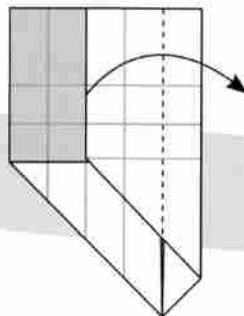

8. Fold to the right.

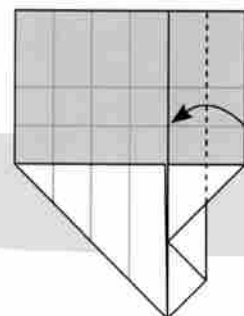

9. Fold to the left.

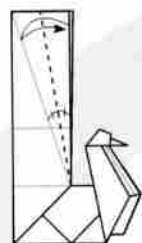

22. Fold and unfold angle bisector through all the layers.

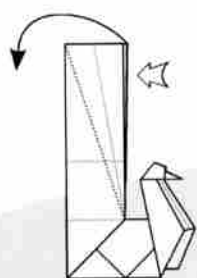

23. Inside reverse fold through the second and third layers.

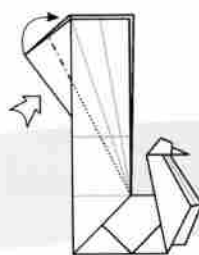

24. Inside reverse fold.

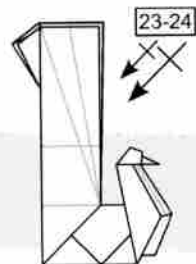

25. Repeat steps 23-24 two more times on the remaining layers.

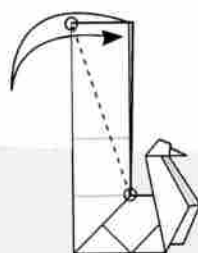

21. Fold and unfold through all the layers.

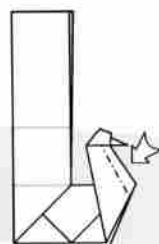

20. Push inside to make the neck 3D.

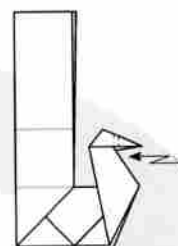

19. Pleat fold inside the model.

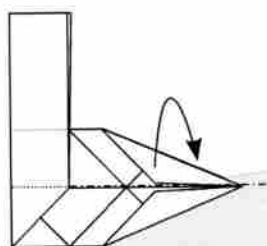

16. Fold behind in half.

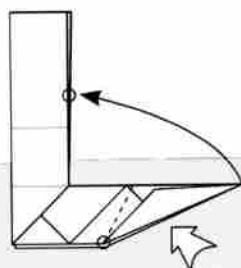

17. Outside reverse fold.

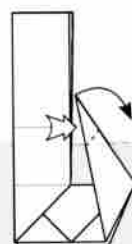

18. Outside reverse fold.

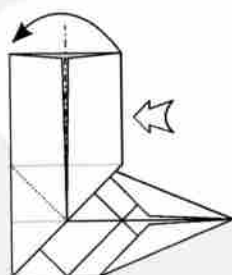

15. Fold behind in half.

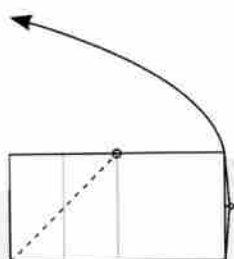

14. Fold up diagonally.

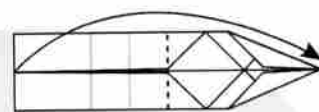

13. Fold the model in half.

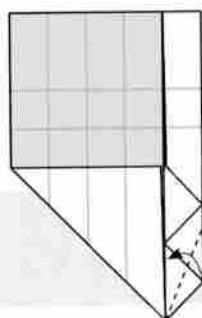

10. Fold the angle bisector.

7-10

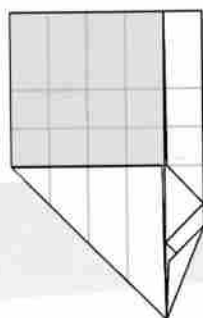

11. Repeat steps 7-10 on the other side.

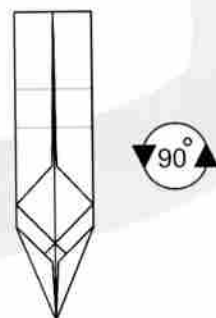

12. Rotate the model.



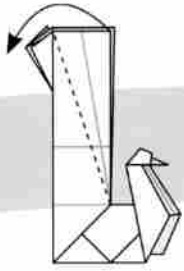

26. Fold to the left.

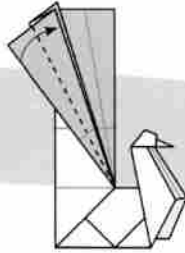

27. Fold to the right.

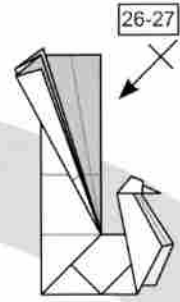

28. Repeat steps 26-27 on the other side.

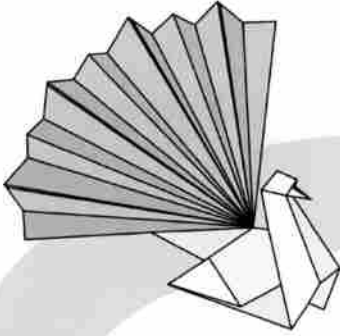

31. Finished open tail peacock!

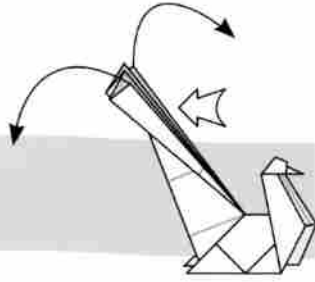

30. Open the tail to the sides.

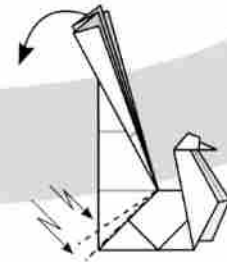

29. Double crimp fold down.

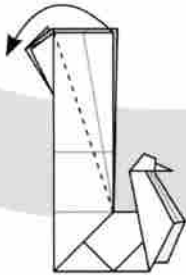

32. Continue from the step 26. Fold the the left.

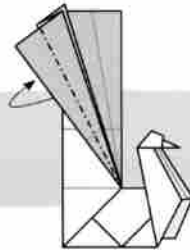

33. Fold behind inside the model.

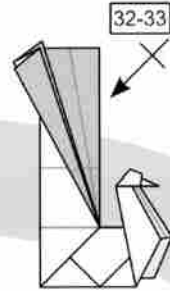

34. Repeat steps 32-33 on the other side.

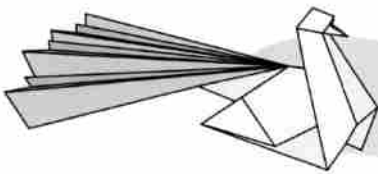

37. Finished closed tail peacock!

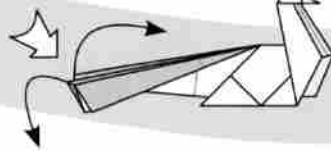

36. Open the tail to the sides.

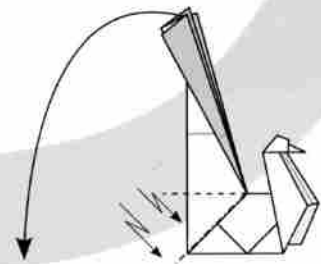

35. Crimp fold down.

# 돼지 머리 Piggy's Head

by Xiaoxian Huang : China

Diagram by Xiaoxian Huang

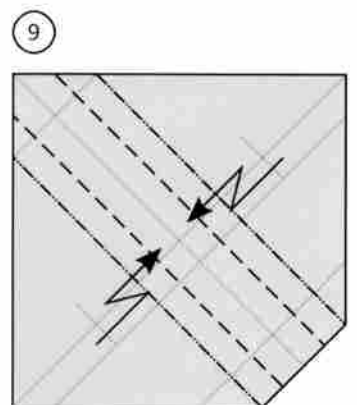
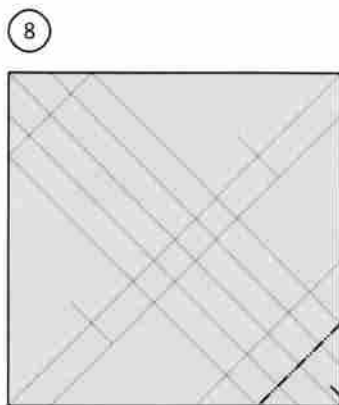
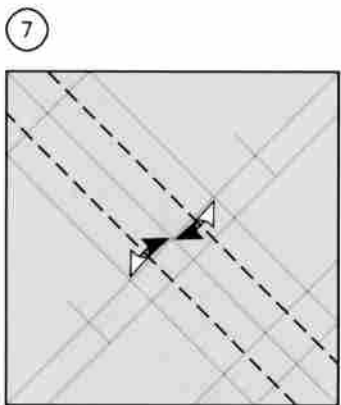
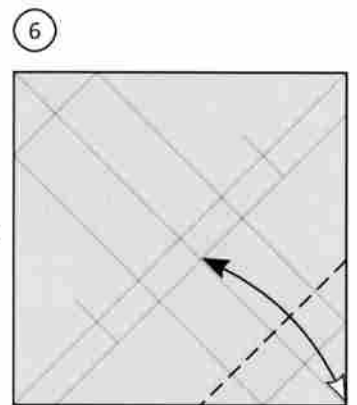
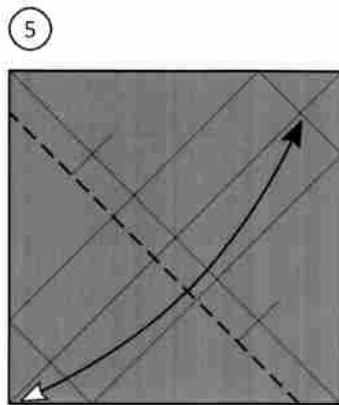
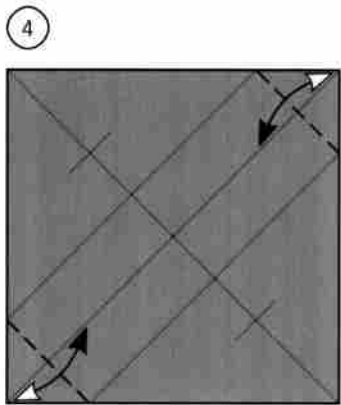
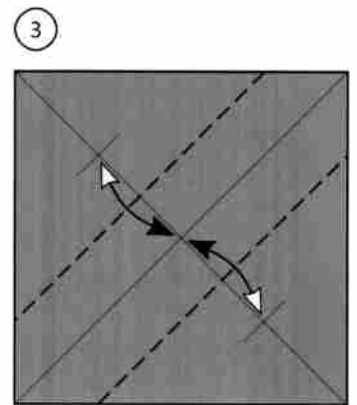
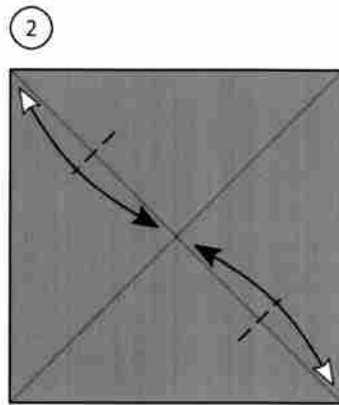
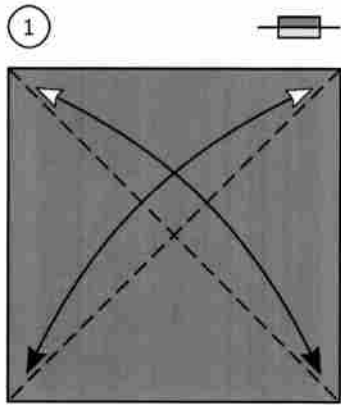
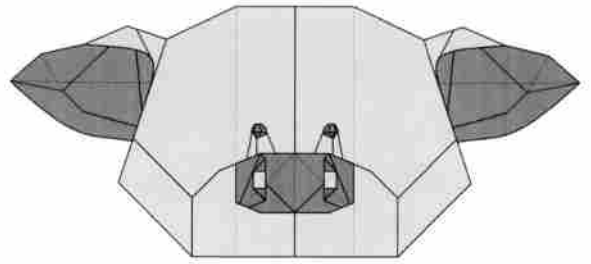

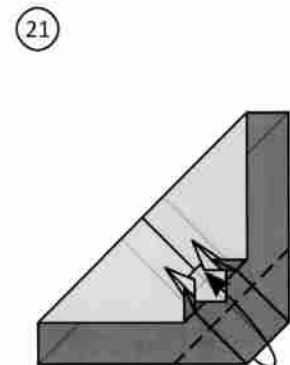
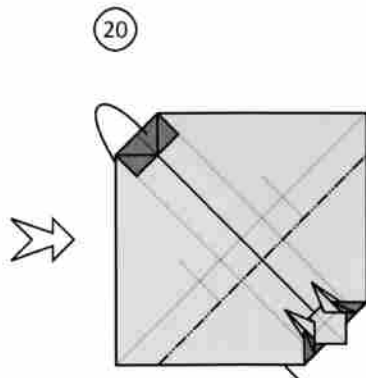
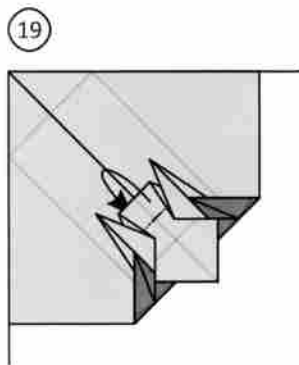
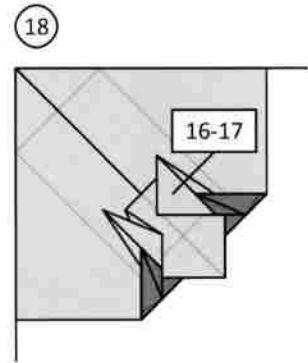
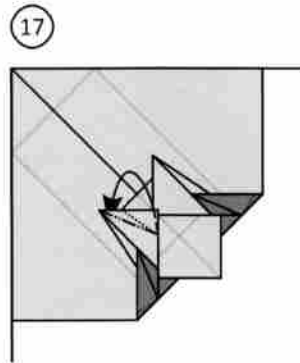
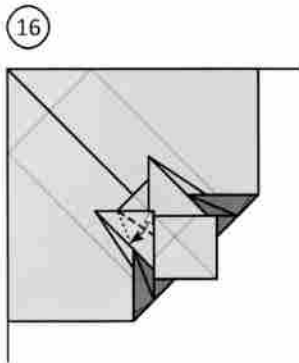
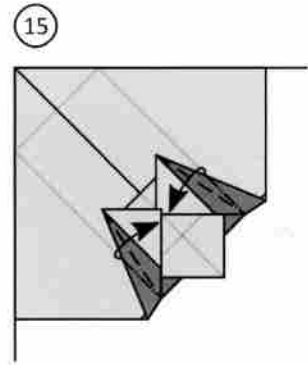
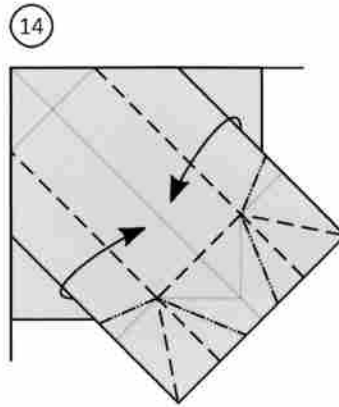
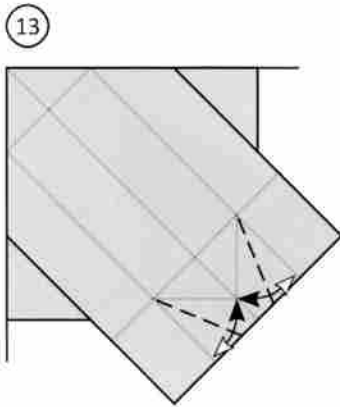
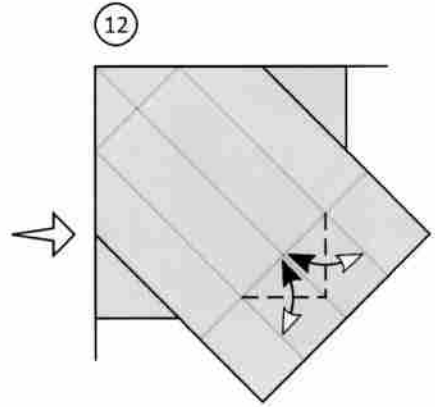
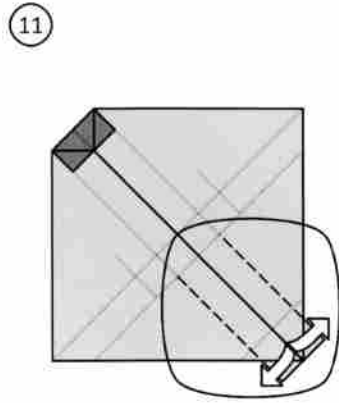
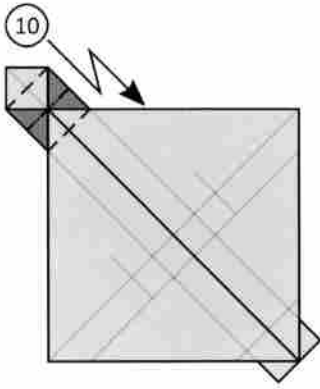

22

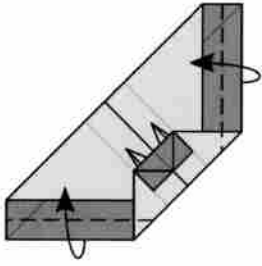

23

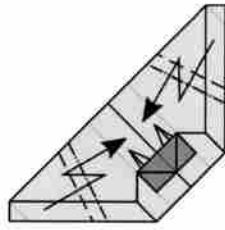

24

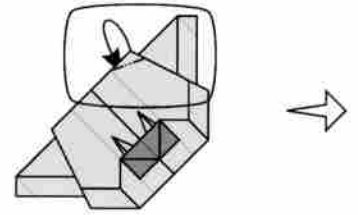

25

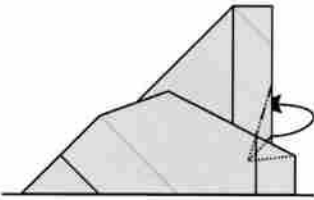

26

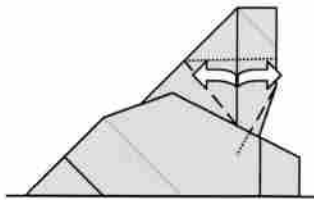

27

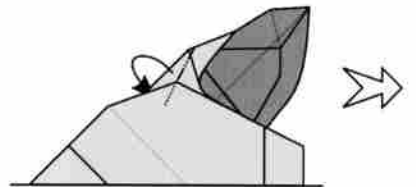

28

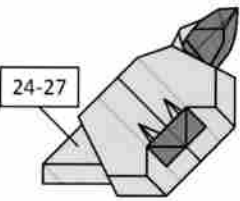

29

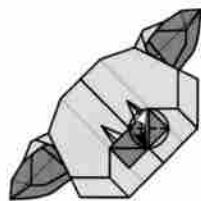

30

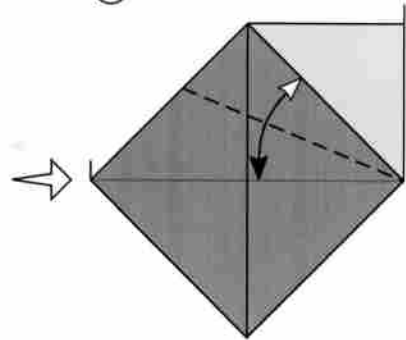

31

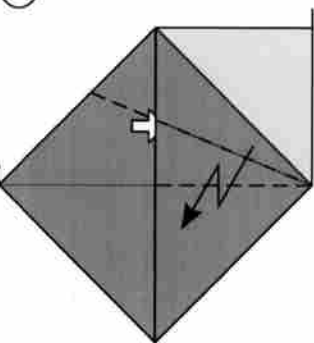

32

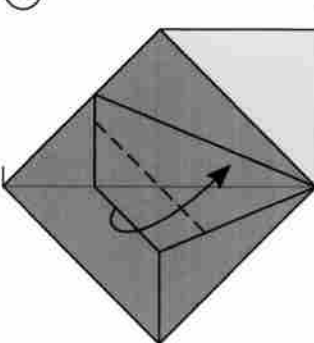

33

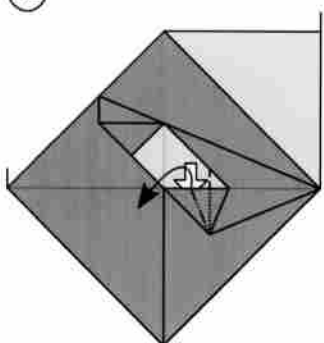

34

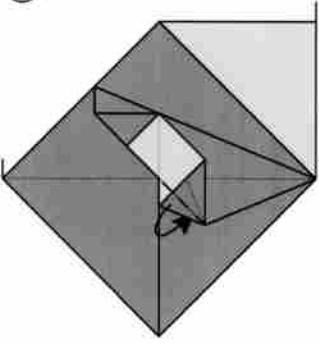

35

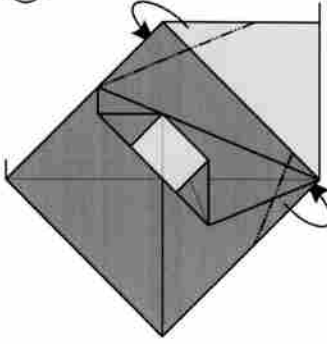

36

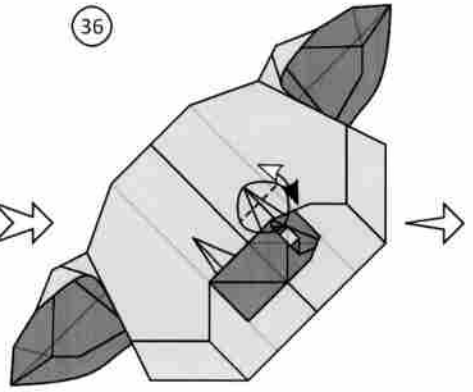

37

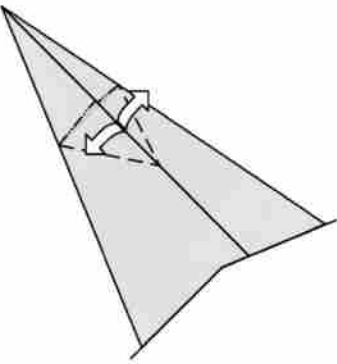

38

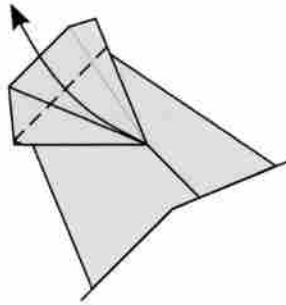

39

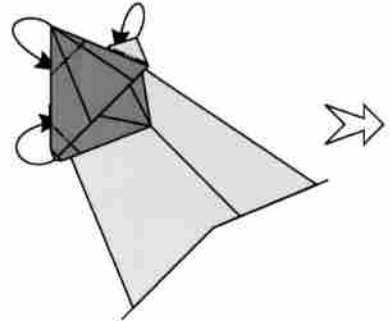

40

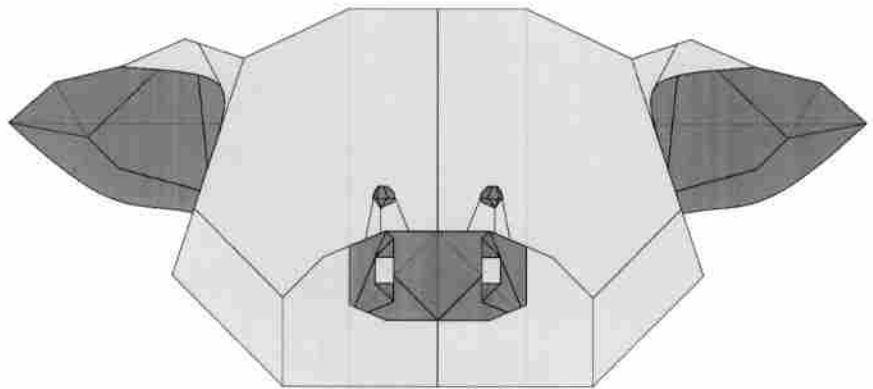
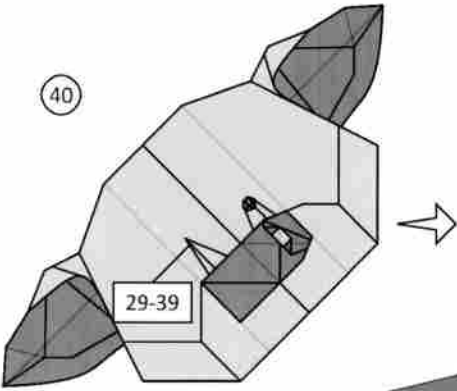

# 페넥여우 Fennec Fox

by Junior Javier Vivanco Garcia : Perú

Diagram by Junior Javier Vivanco Garcia

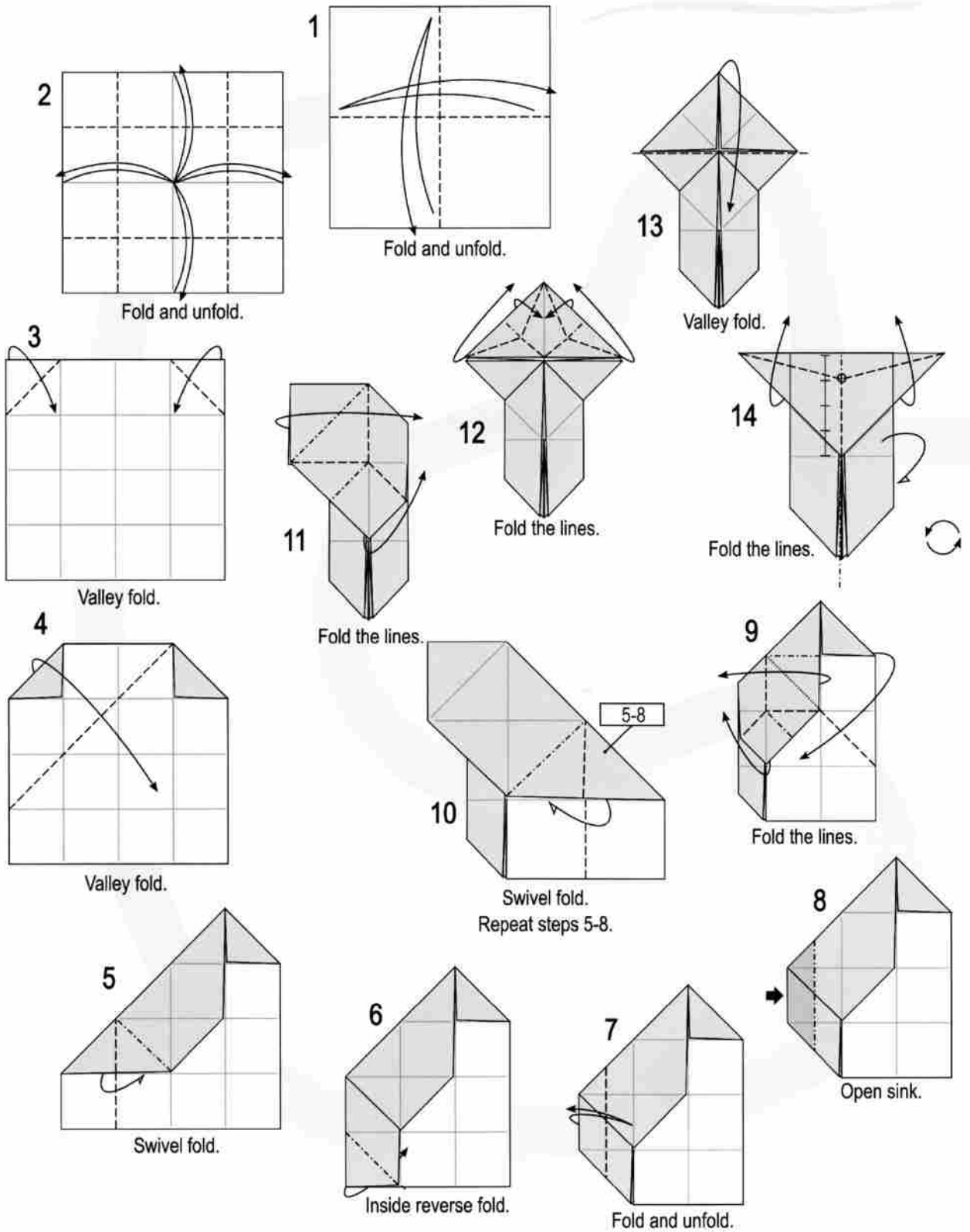
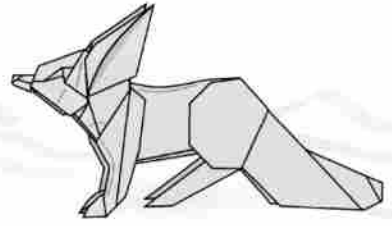

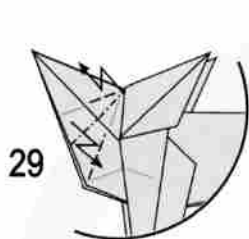

29

Crimp fold.  
Repeat on the back.

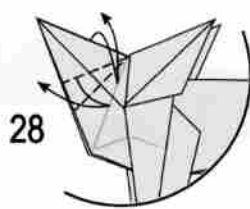

28

Fold and unfold.

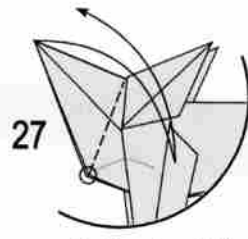

27

Fold and unfold.

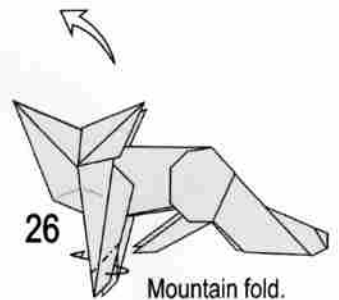

26

Mountain fold.  
Repeat on the back.

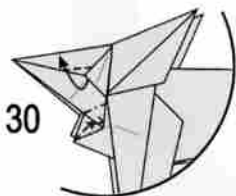

30

Swivel fold.  
Repeat on the back.



32

Outside reverse fold.

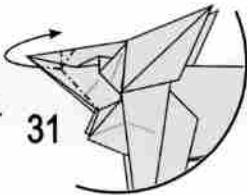

31

Fold the lines.

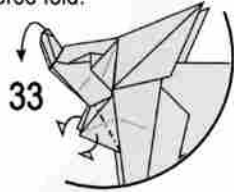

33

Shape the nose.  
Mountain fold.

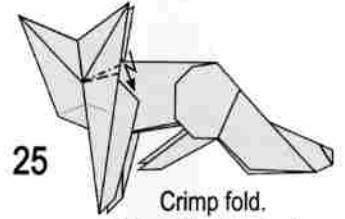

25

Crimp fold.  
Repeat on the back.

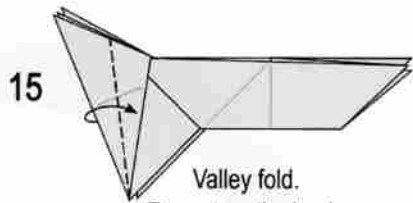

15

Valley fold.  
Repeat on the back.

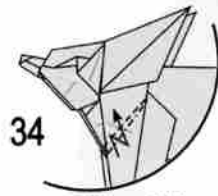

34

Crimp fold.  
Repeat on the back.

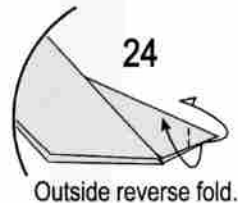

24

Outside reverse fold.

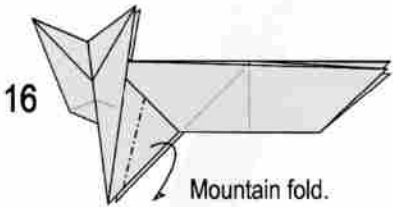

16

Mountain fold.  
Repeat on the back.

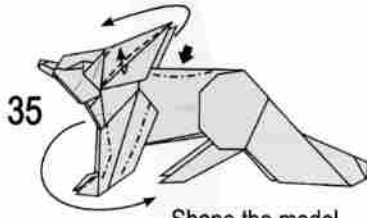

35

Shape the model.

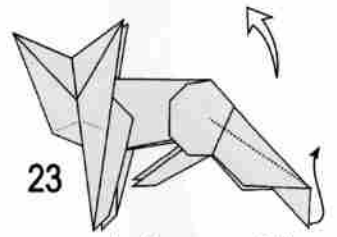

23

Inside reverse fold.

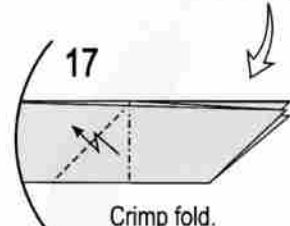

17

Crimp fold.  
Repeat on the back.

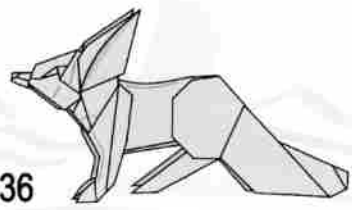

36

Model finished.

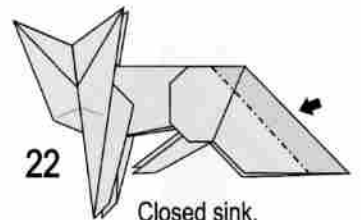

22

Closed sink.

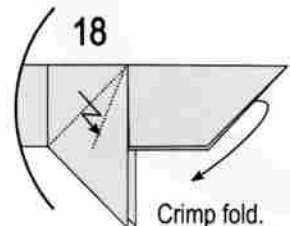

18

Crimp fold.

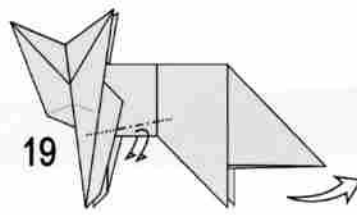

19

Mountain fold.  
Repeat on the back.

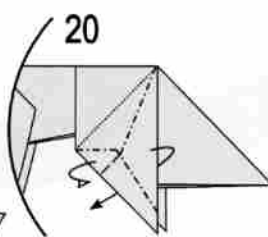

20

Rabbit ear fold.  
Repeat on the back.

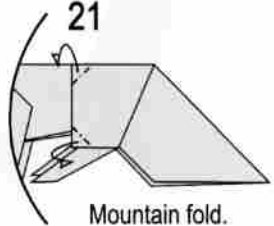

21

Mountain fold.  
Repeat on the back.

# 페가수스 1.0 Pegasus 1.0

by Pham Hoang Tuan : Vietnam

Diagram by Pham Hoang Tuan

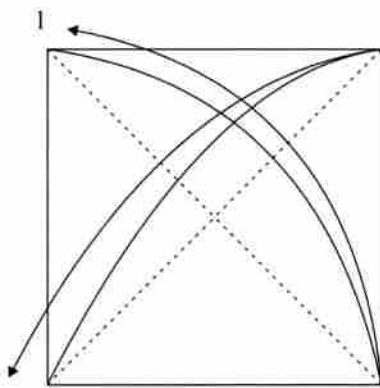
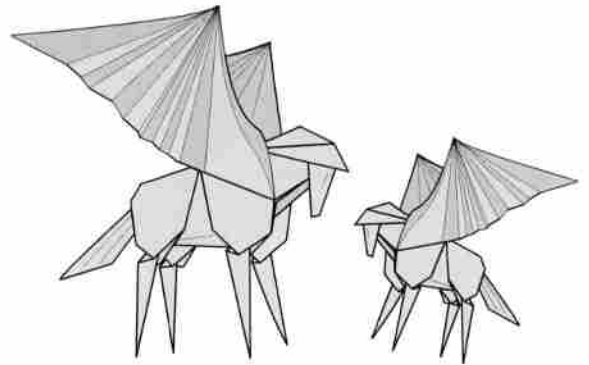

Make creases

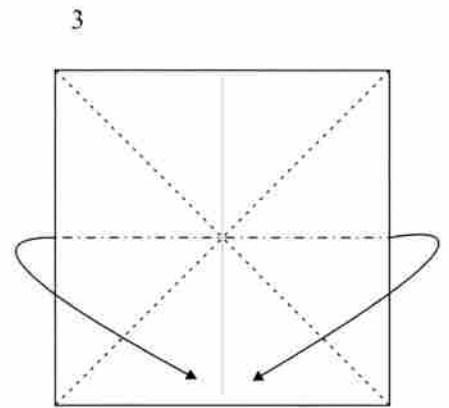
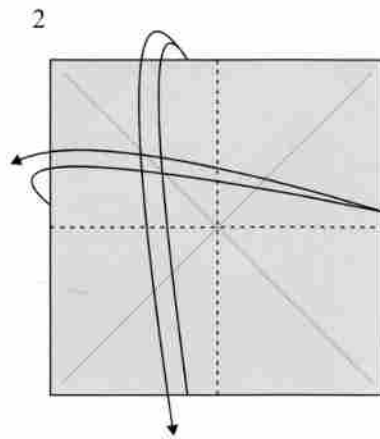

Frog base collapse

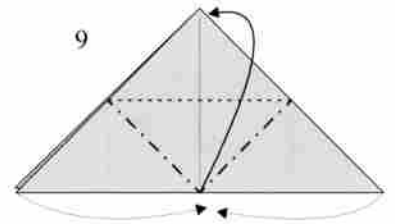
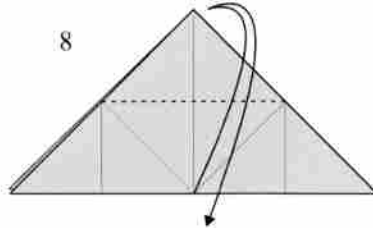
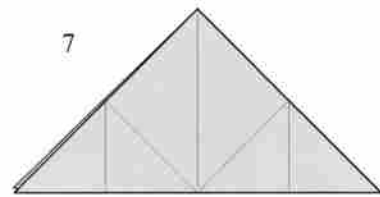
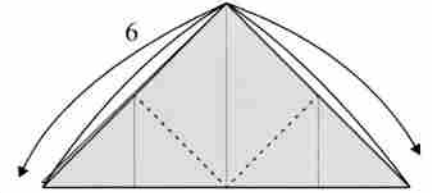
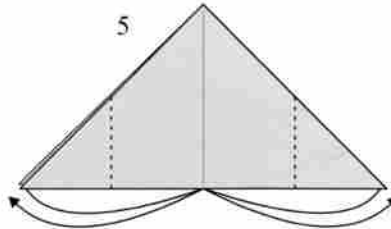
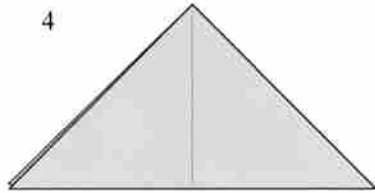

Fold up, using creased lines

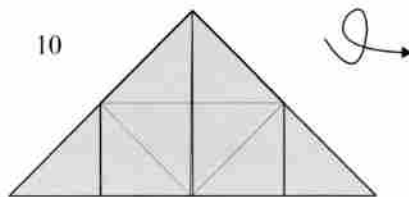

Turn over

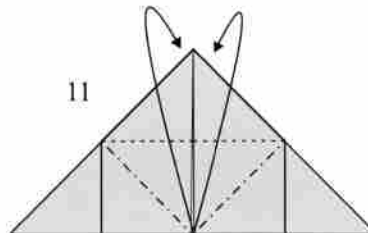

Squash fold up

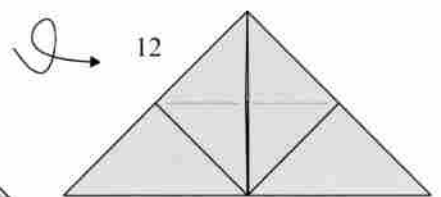



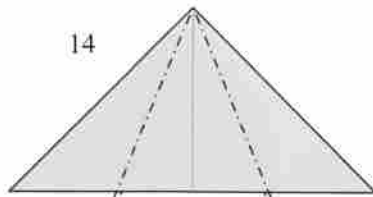
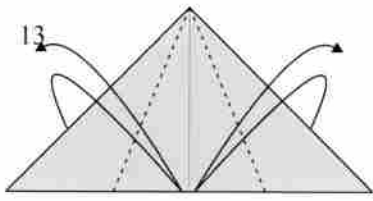

Inside reversed fold.

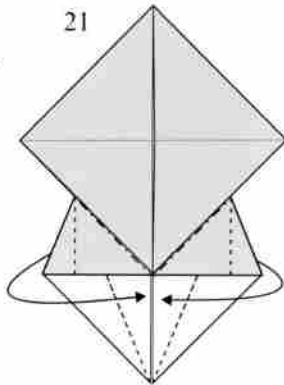
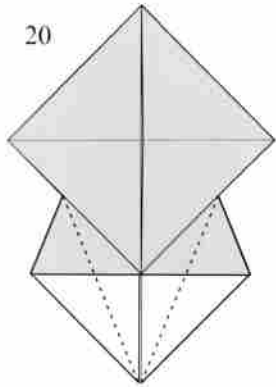
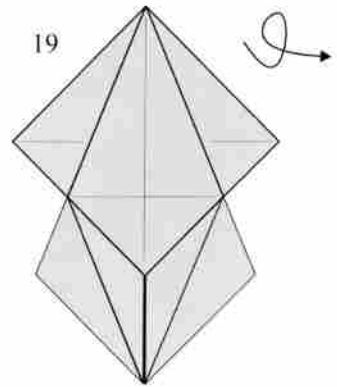
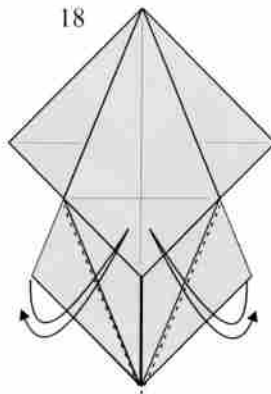
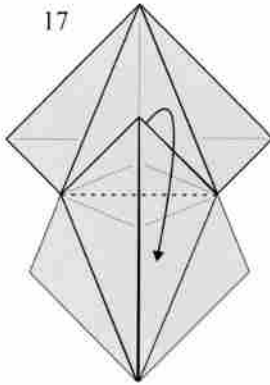
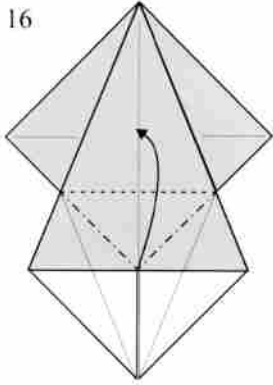
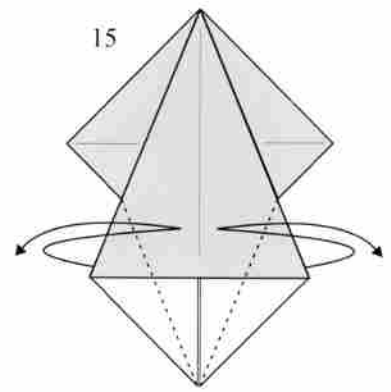

Repeat step 15-18

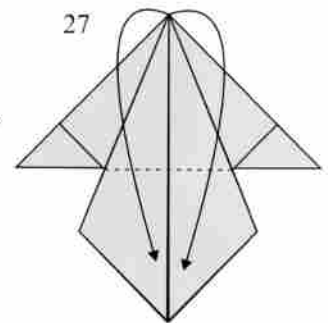
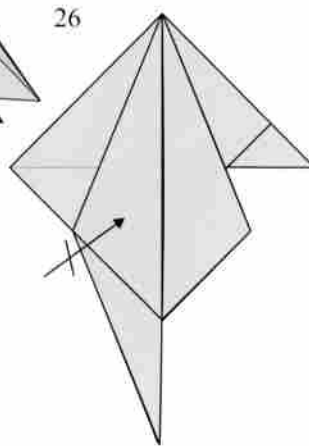
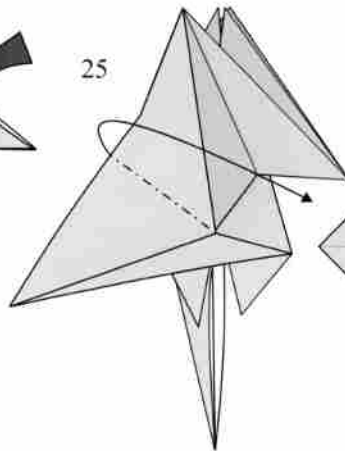
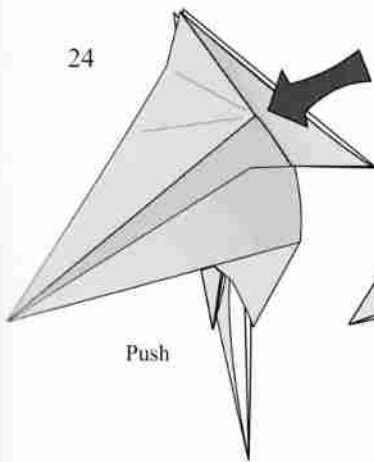
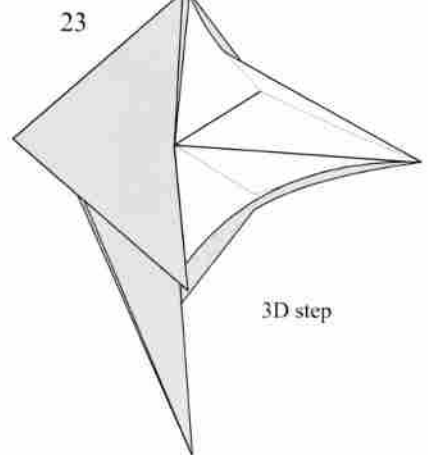
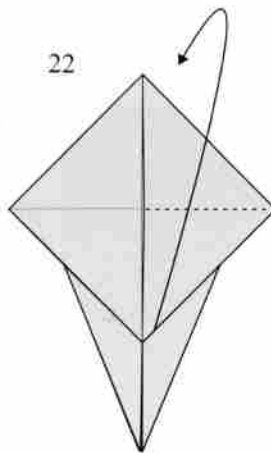

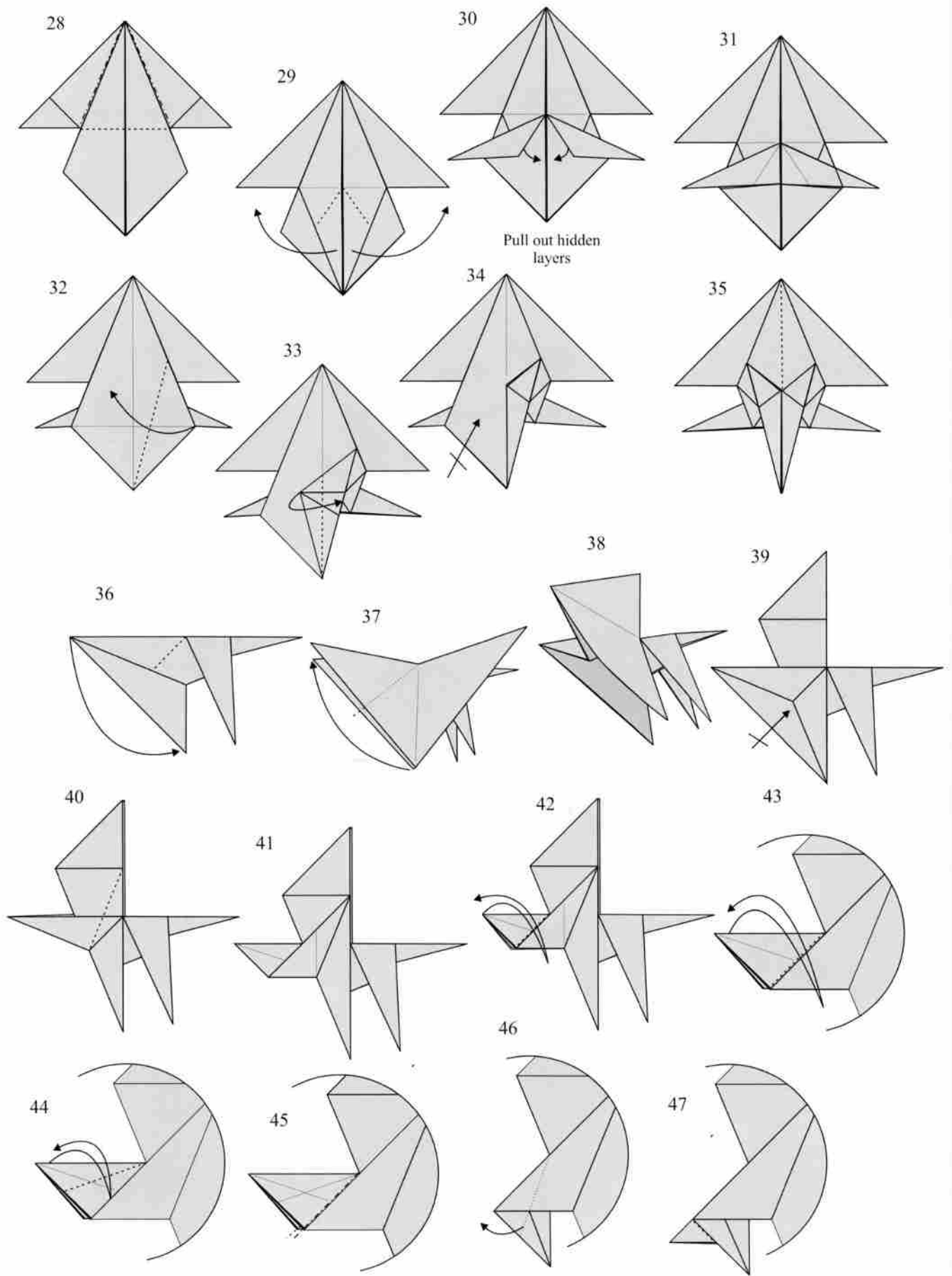

48

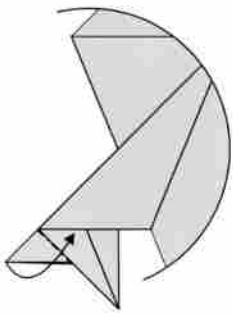

49

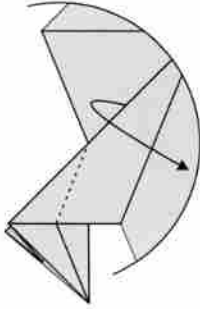

50

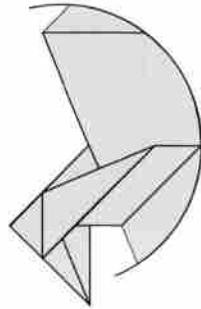

51

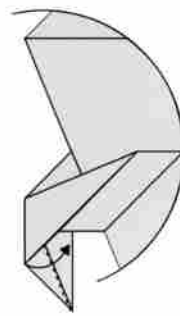

52

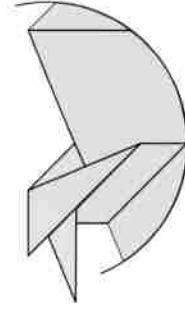

53

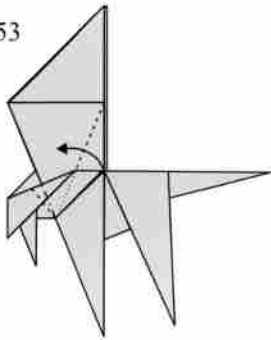

54

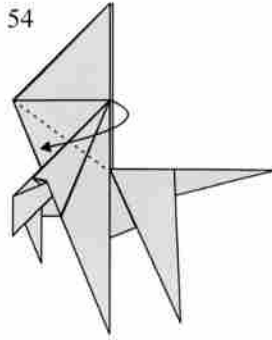

55

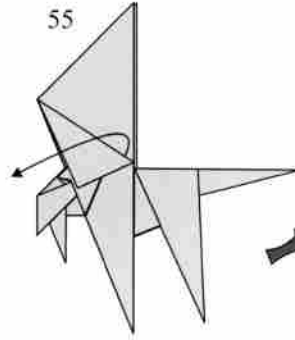

56

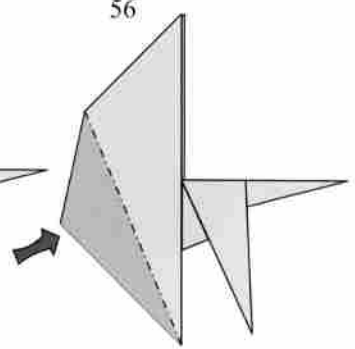

57

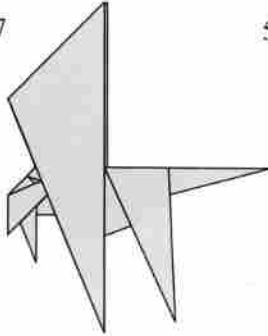

58

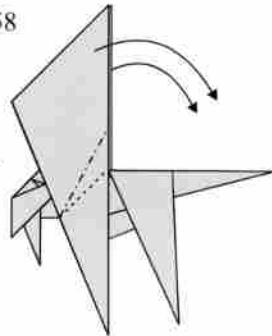

59

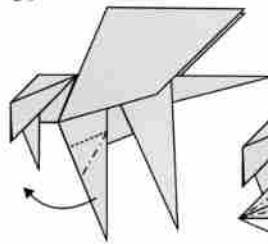

60

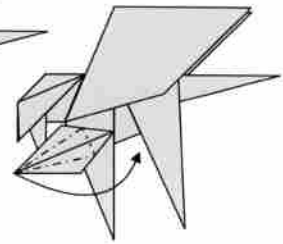

61

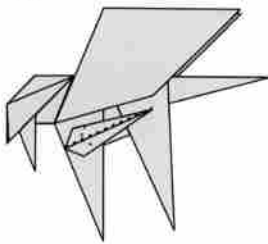

62

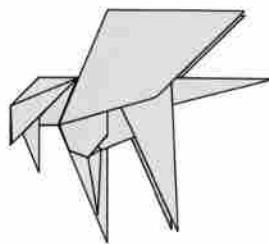

63

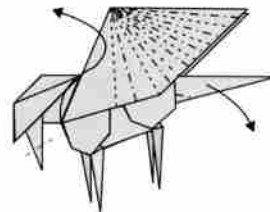

Shape the head, wings and tail.

Repeat on the other legs

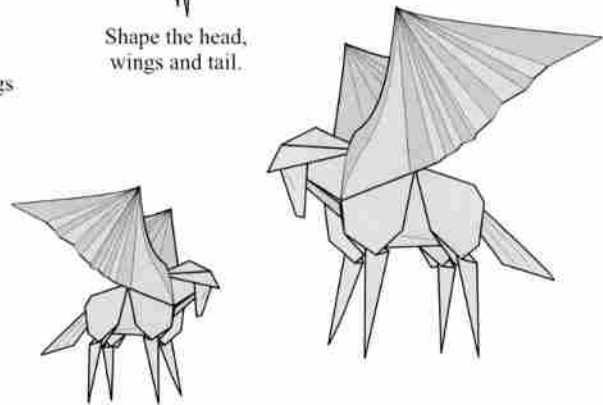

# 사슴 헌팅 트로피

## Deer Hunting Trophy

by Ko YiNyeo : Korea

Diagram by Cho KyungSuk

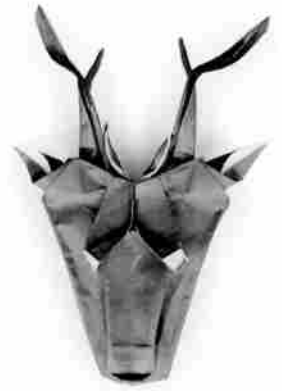

①

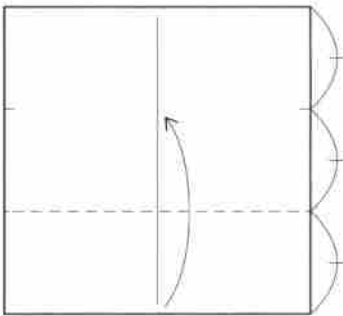

②

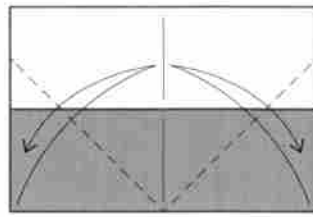

③

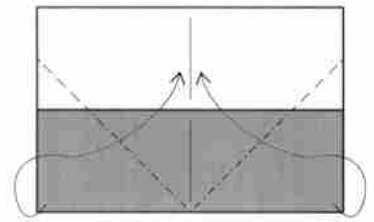

④

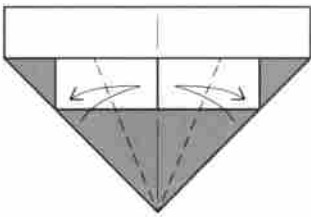

⑤

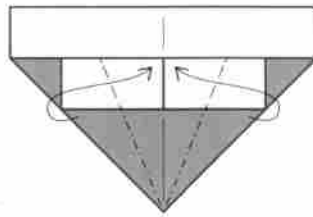

⑥

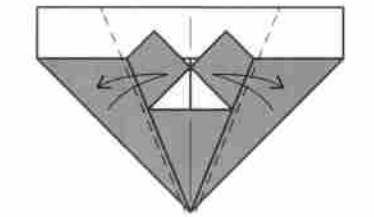

⑦

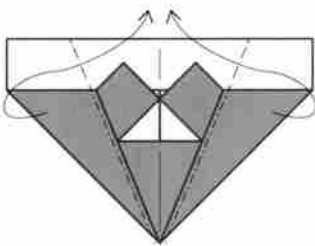

⑧

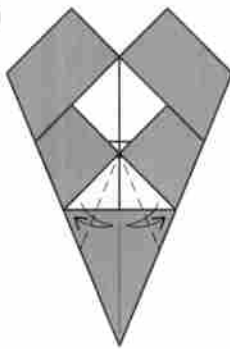

⑨

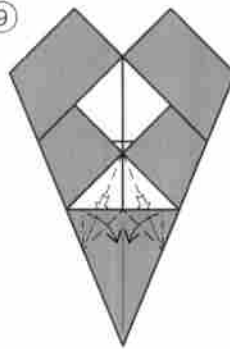

⑩

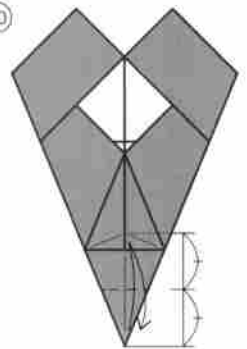

⑪

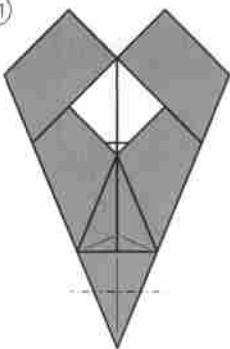

⑫

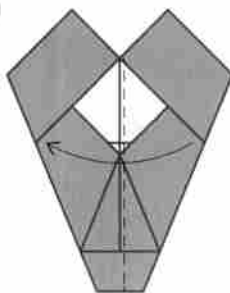

⑬

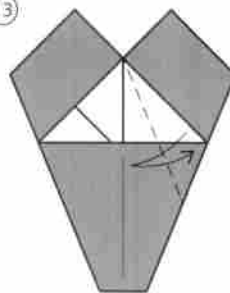

⑭

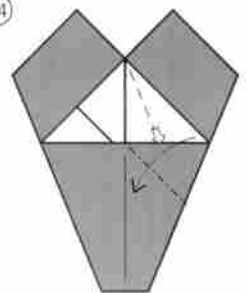

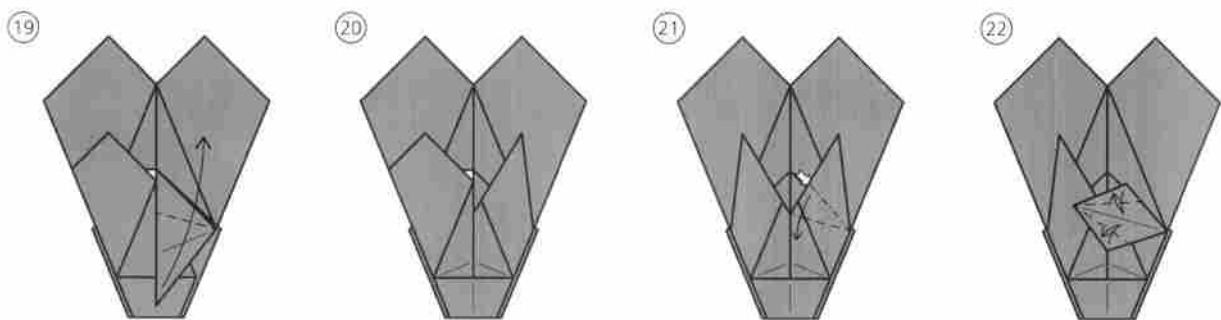
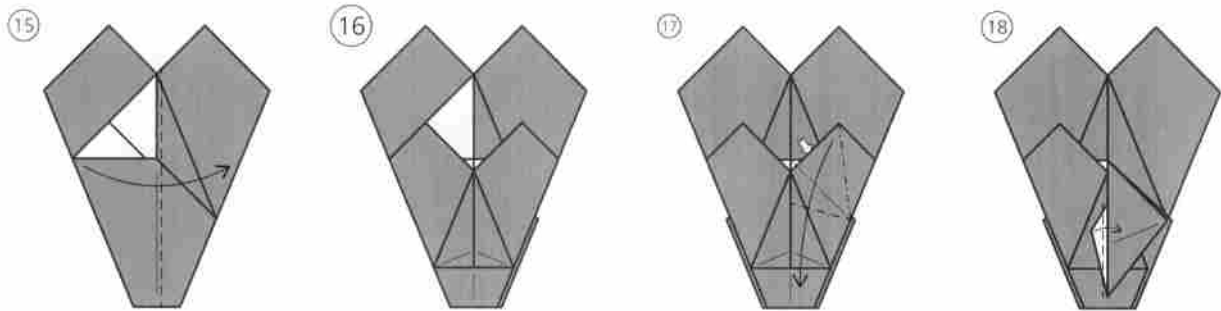

반대쪽도 같은 방법으로 접으세요.

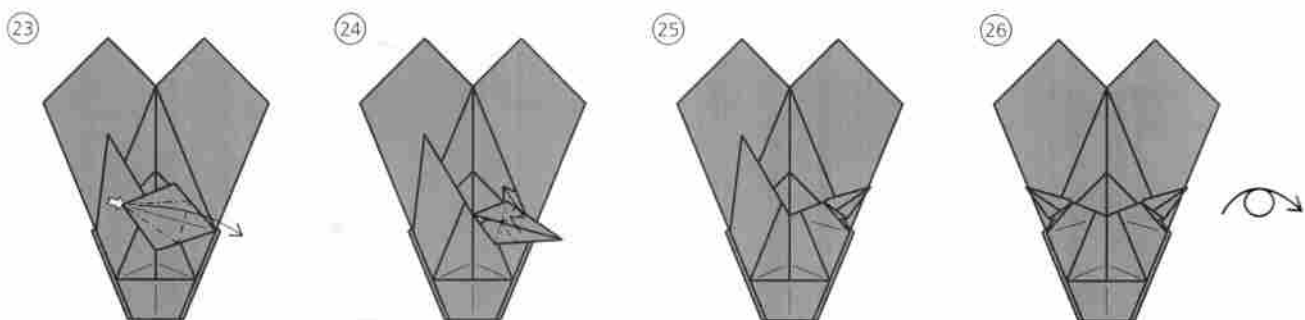

반대쪽도 같은 방법으로 접으세요.

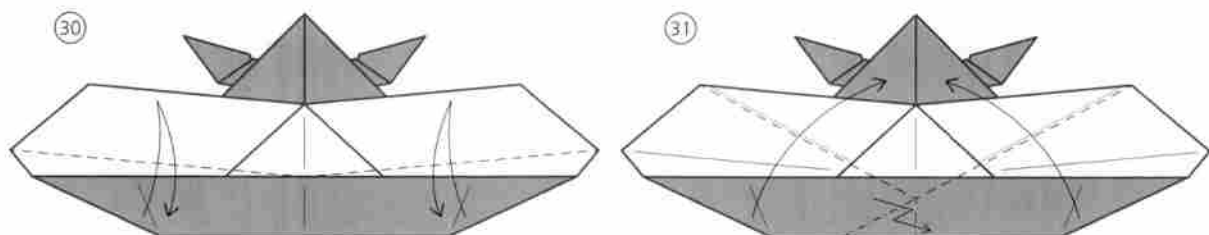
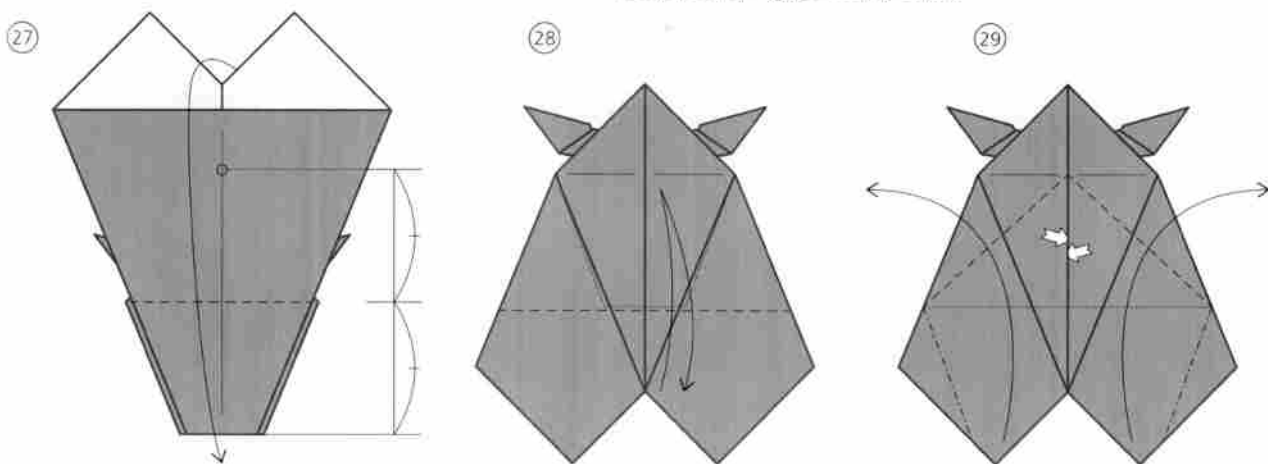

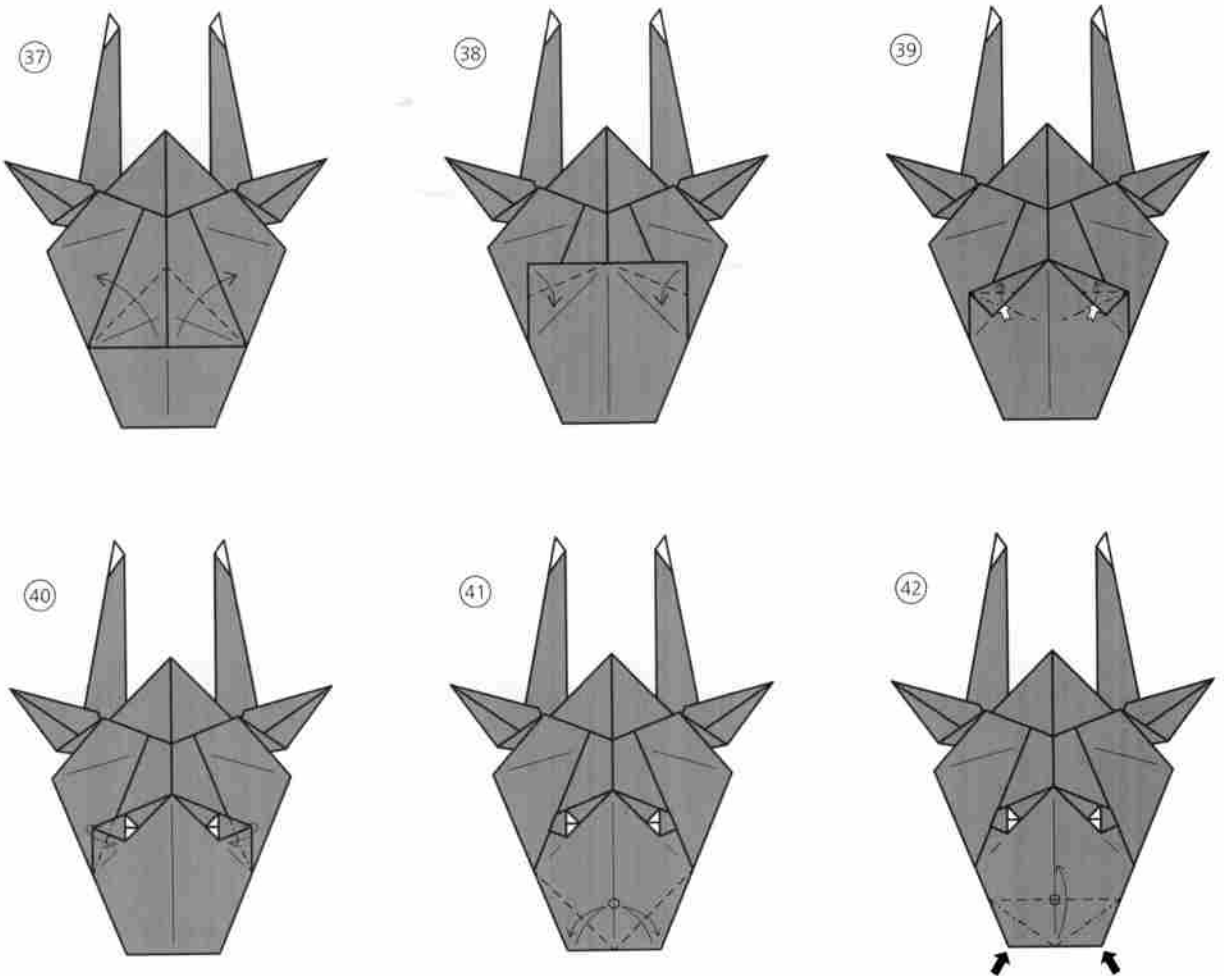
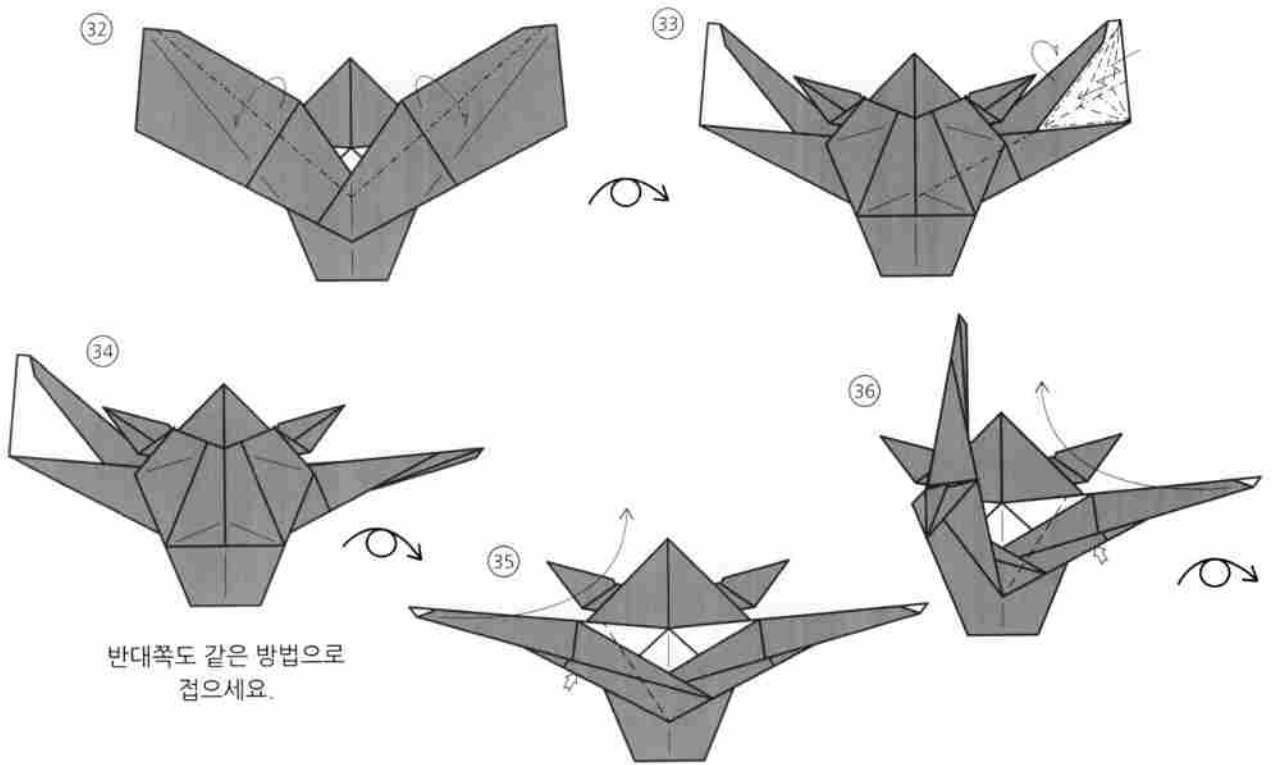

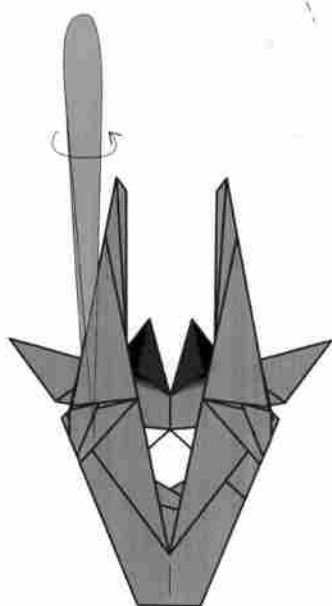
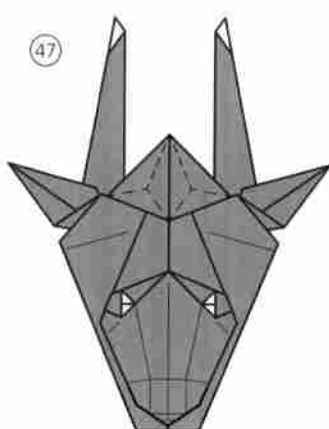
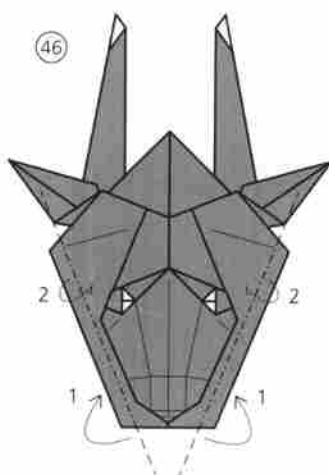
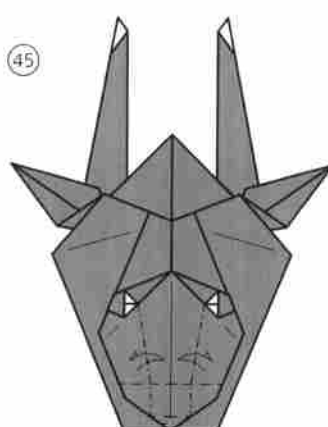
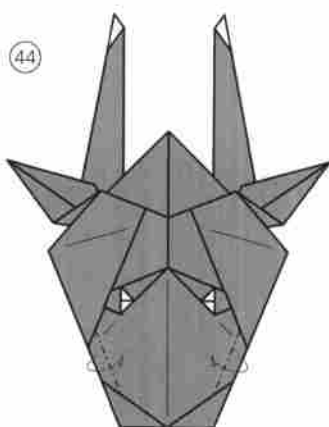
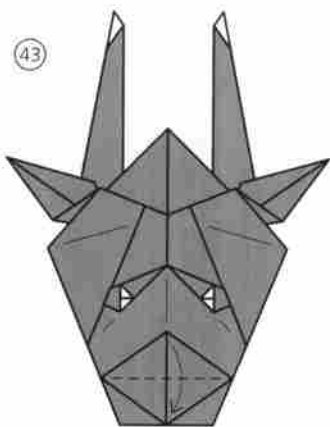

핀셋으로 돌려 말아주세요.



완성

# 흡혈 박쥐 Vampire Bat

by Pham Minh Thiên Thành : Vietnam

Diagram by Pham Minh Thiên Thành

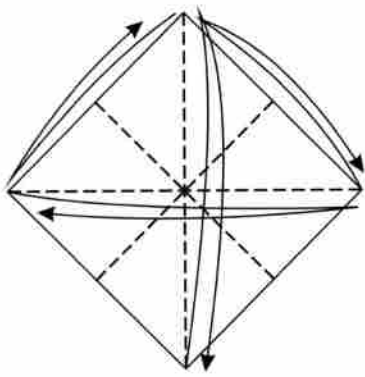

1.

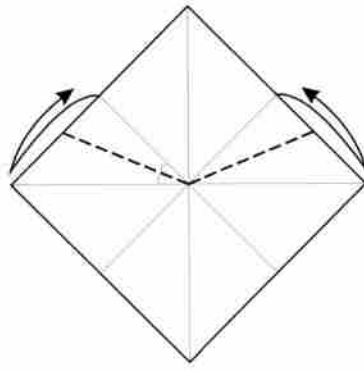

2.

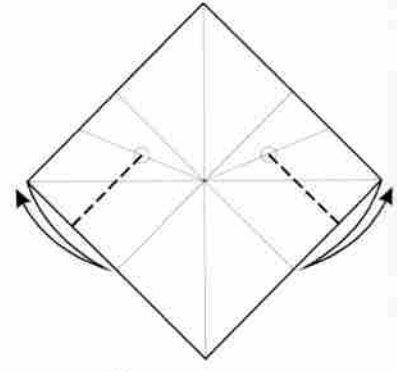

3.

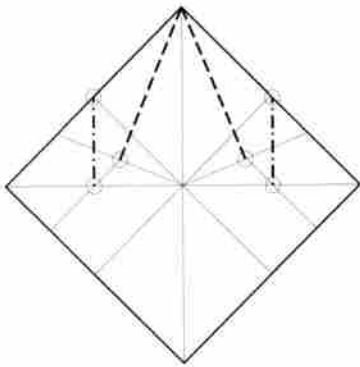

4.

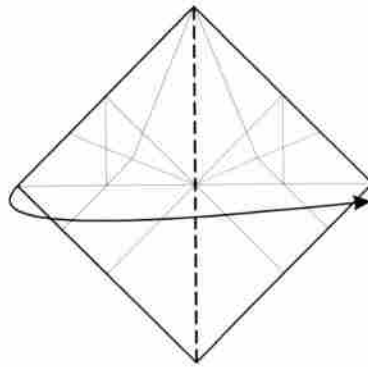

5.

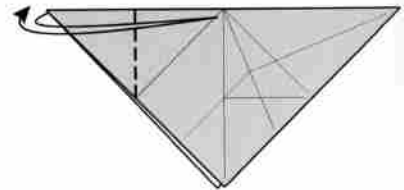

6.

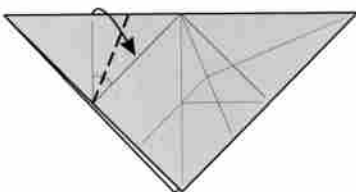

7.

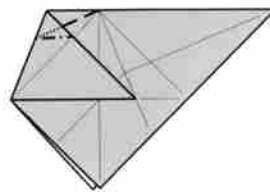

8.

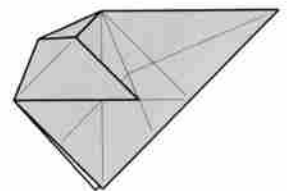

9. return in step 6



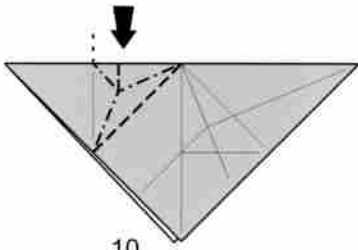

10.

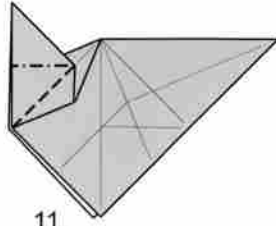

11.

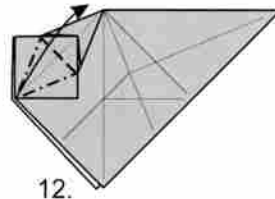

12.

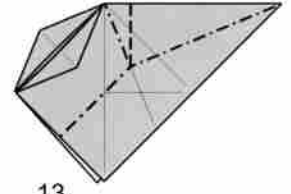

13.

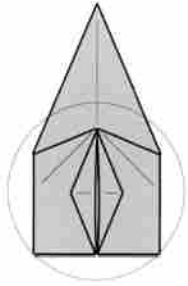

14. zoom in

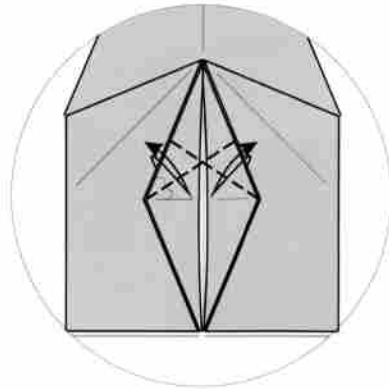

15.

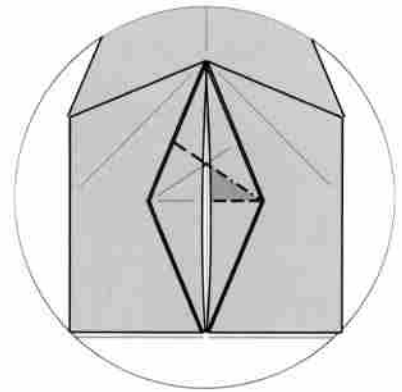

16.

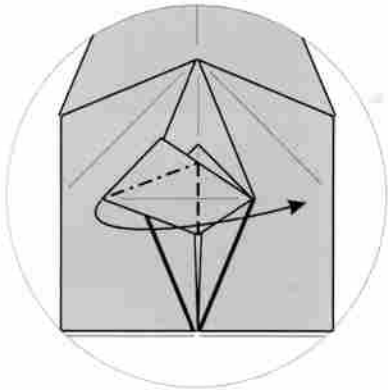

17.

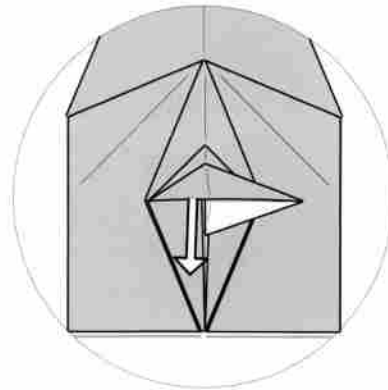

18. pull out the inside layer

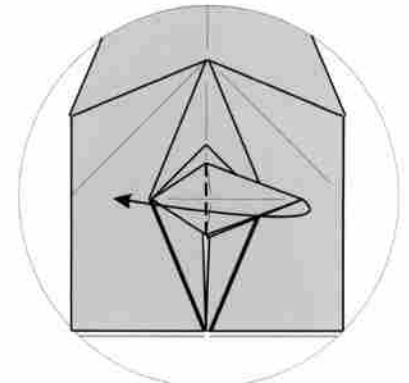

19.

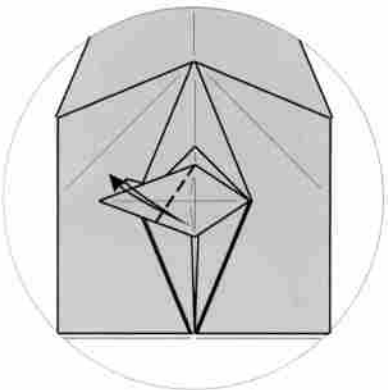

20.

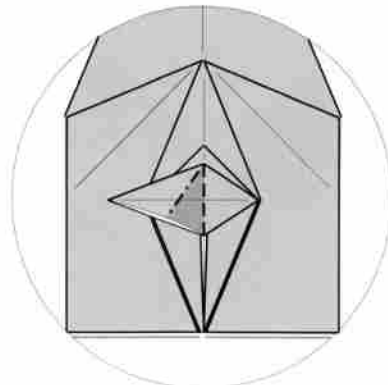

21.

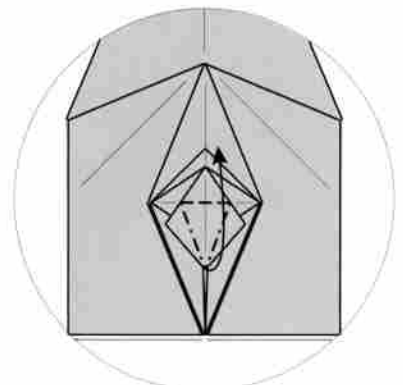

22.

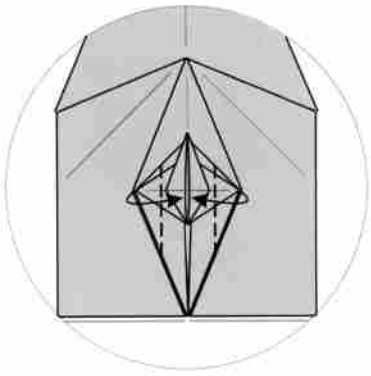

23. fold 1 layer

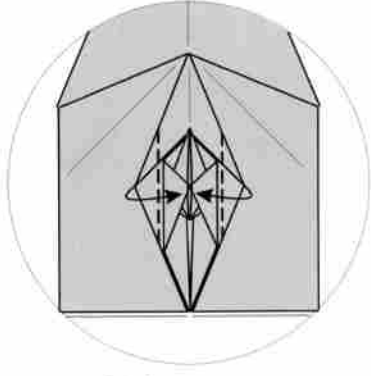

24. have a space

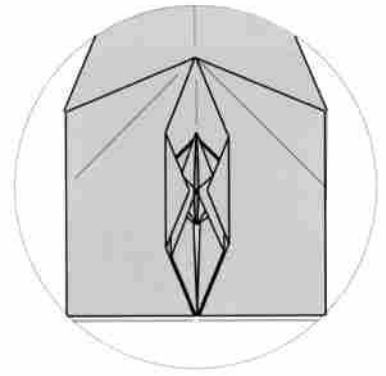

25. return in step 23

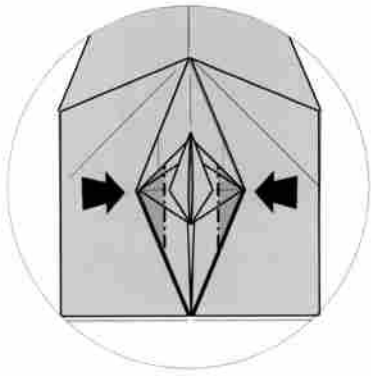

26. sink 1 layer

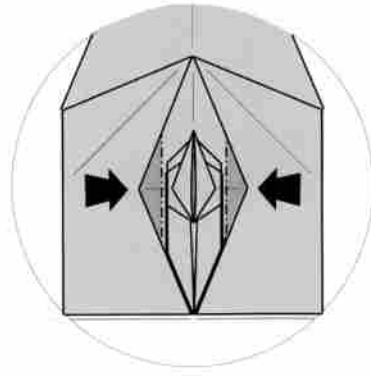

27. sink again

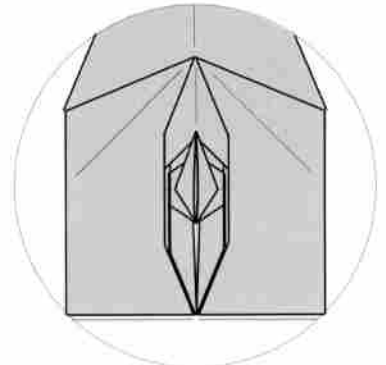

28. zoom out

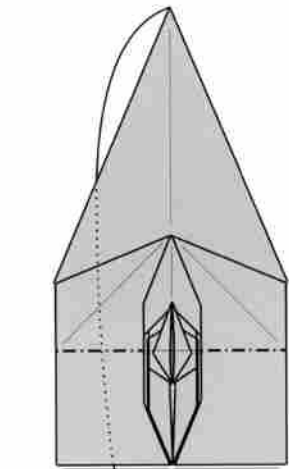

29.

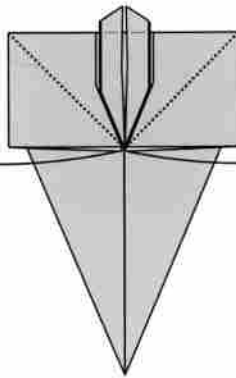

30.

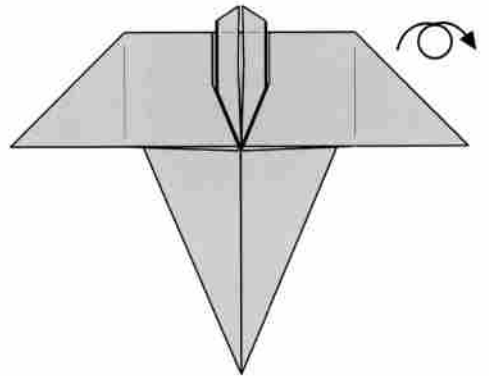

31.

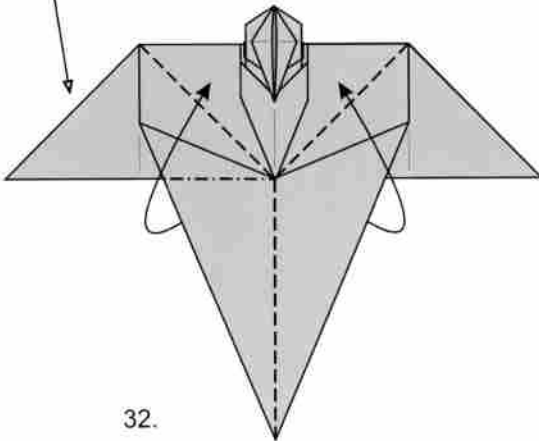

32.

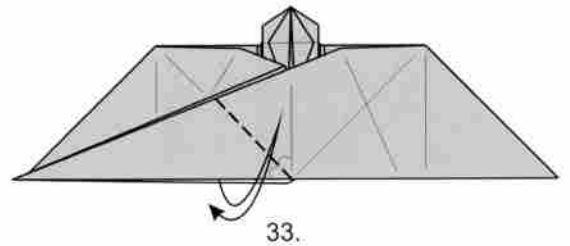

33.

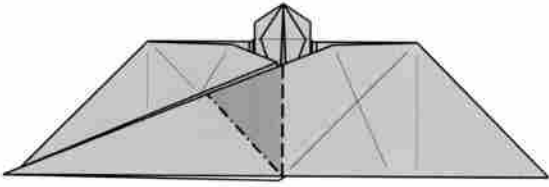

34.

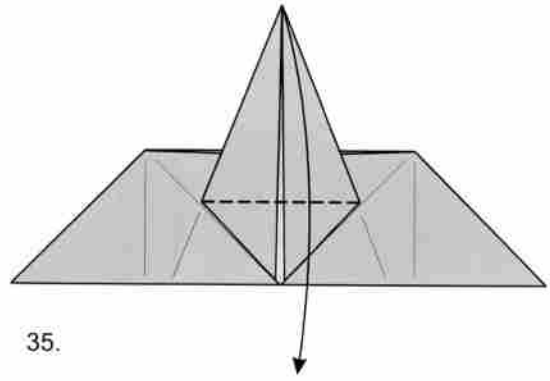

35.

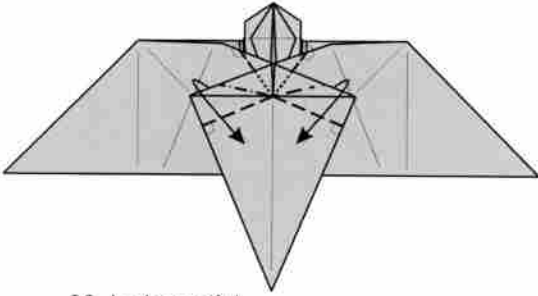

36. look careful

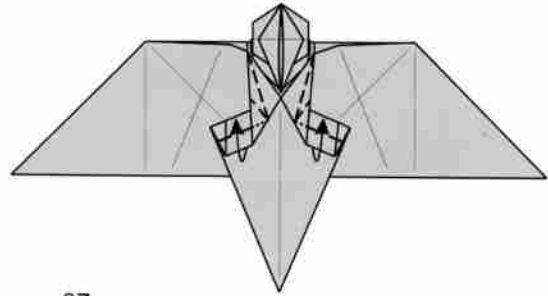

37.

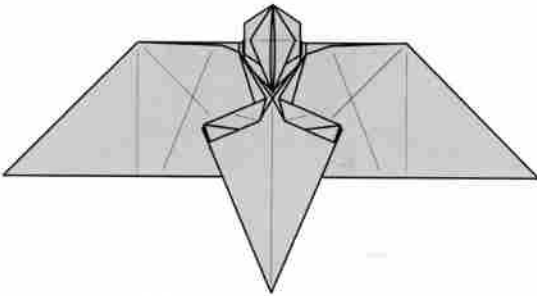

38. return in step 32.

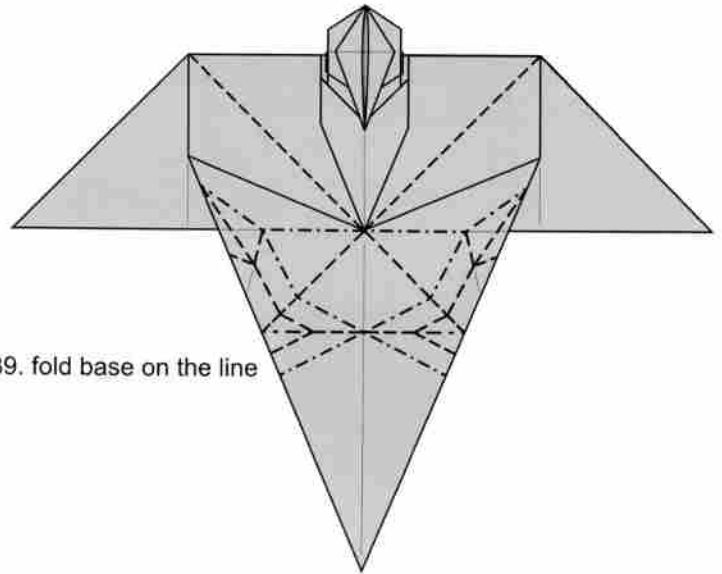

39. fold base on the line

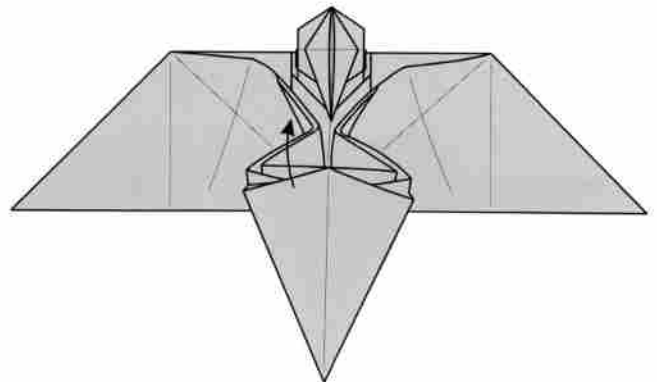
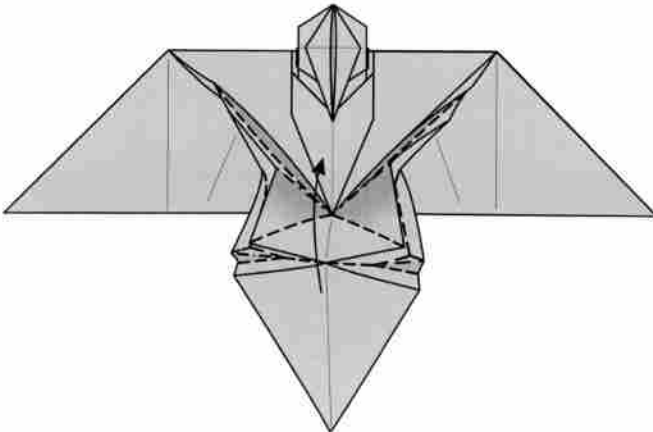

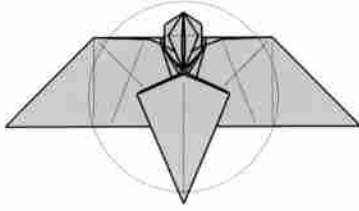

40. zoom in

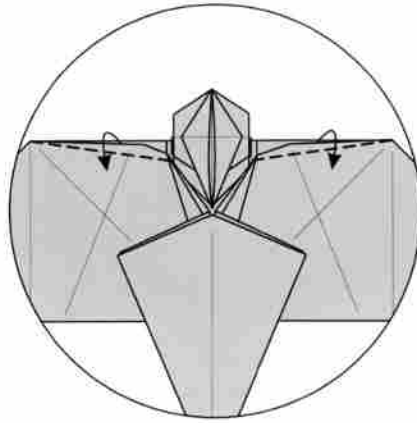

41.

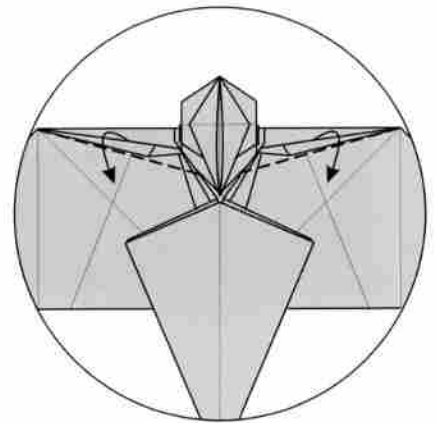

42.

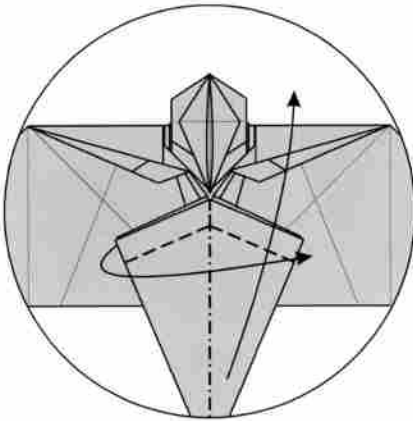

43.

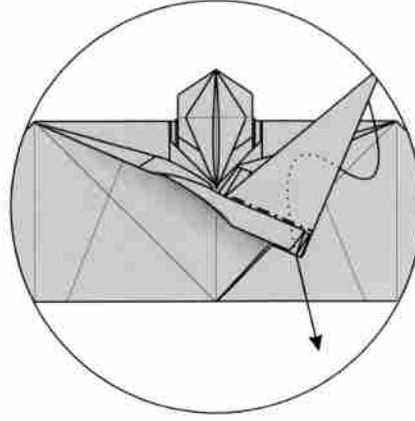

44.

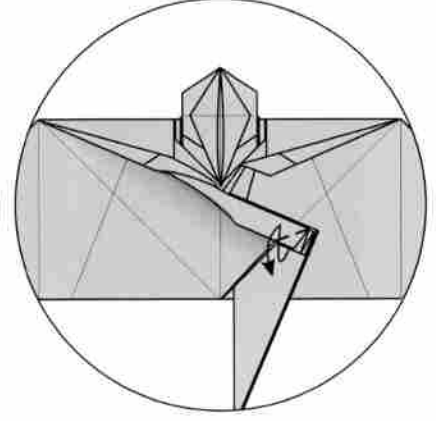

45.

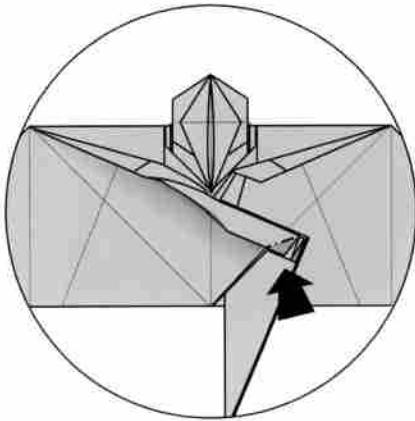

46.

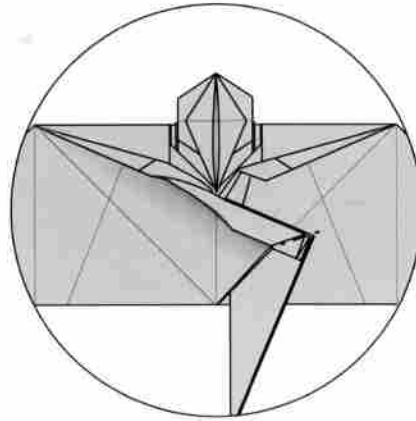

47.

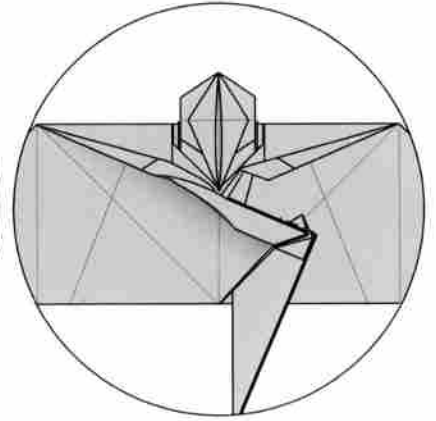

48.

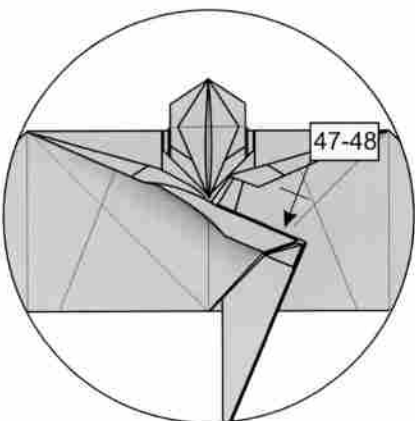

49. repeat on the final layer

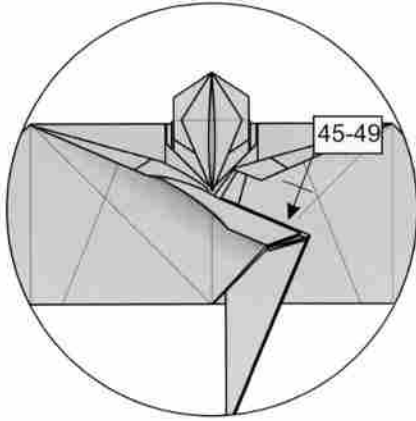

50. repeat on the right

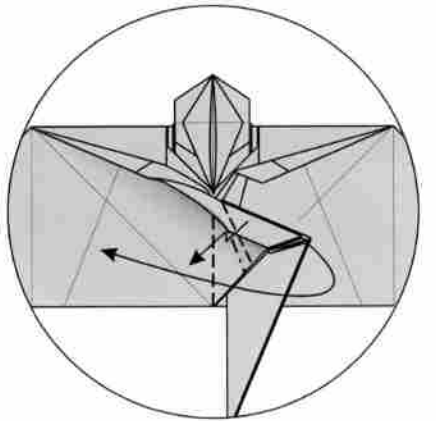

51.

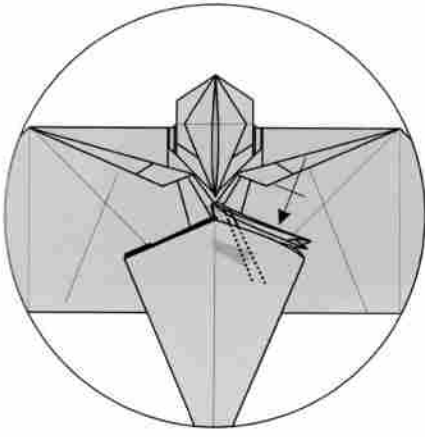

52. repeat on the right

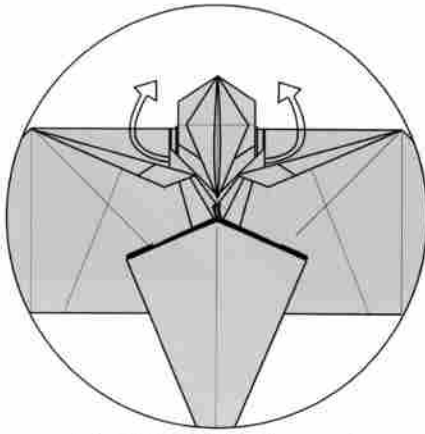

53. pull the under layer out

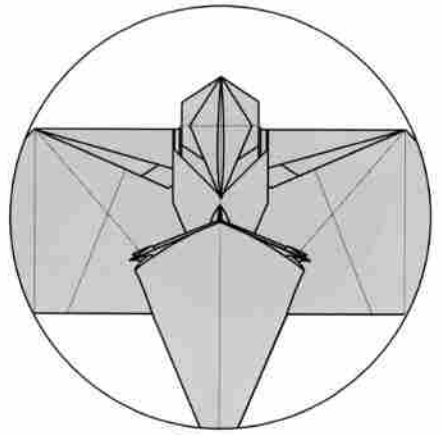

54. zoom out

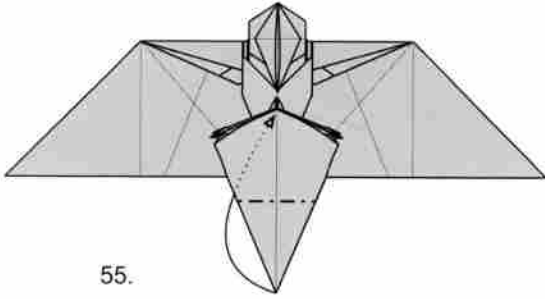

55.

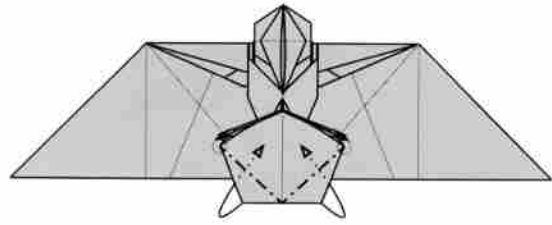

56.

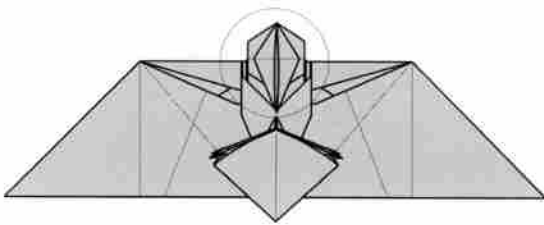

57. zoom in

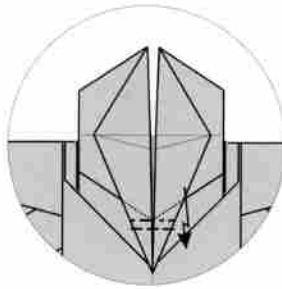

58.

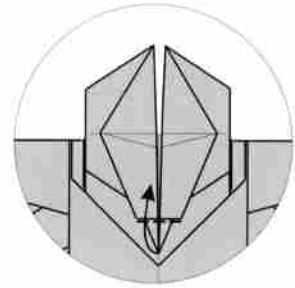

59.

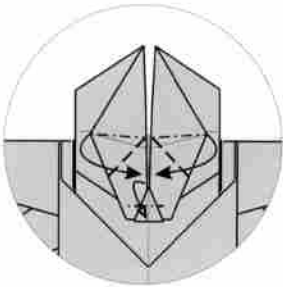

60.

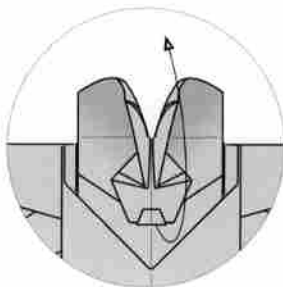

61.

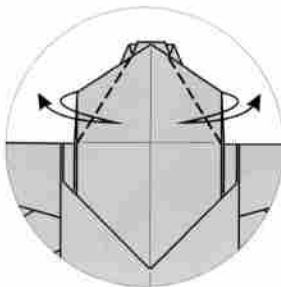

62

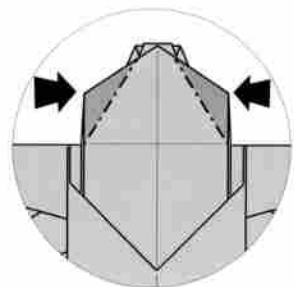

63. sink

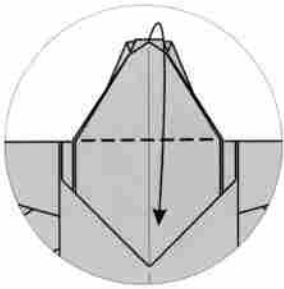

64.

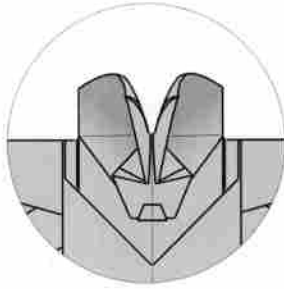

65. zoom out

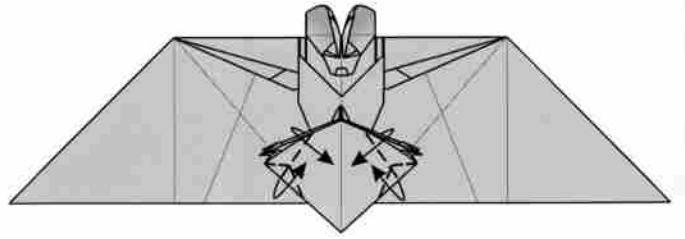

65.

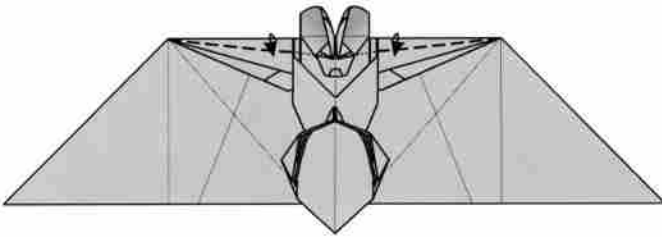

66.

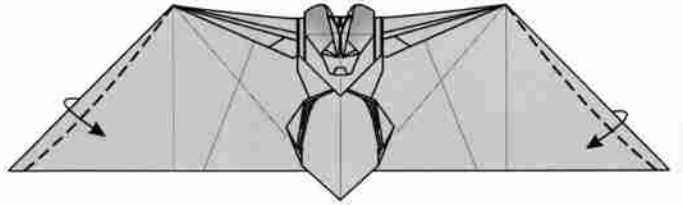

67.

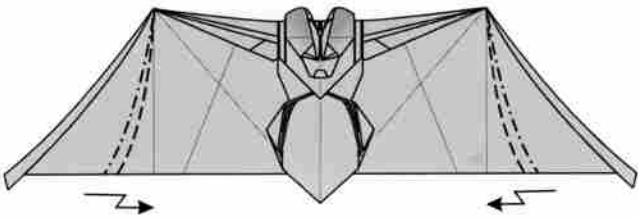

68.

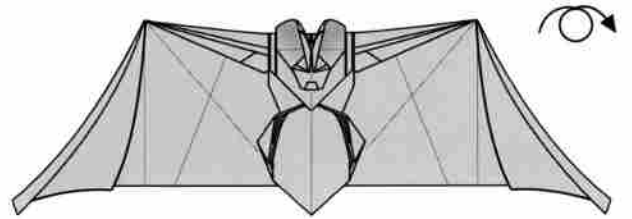

69.

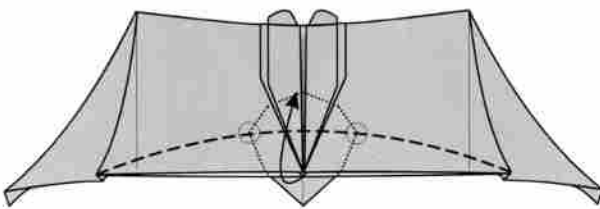

70.

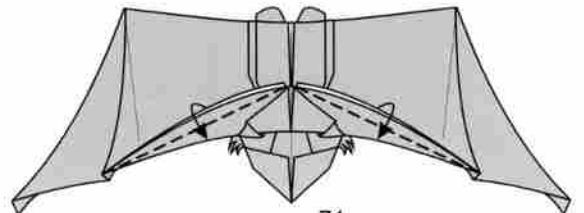

71.

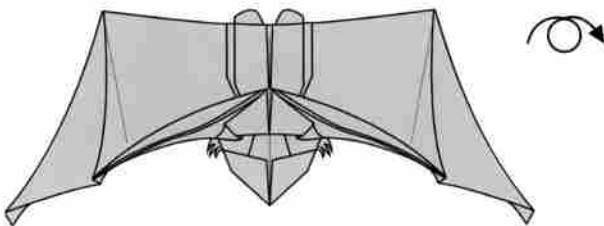

72.

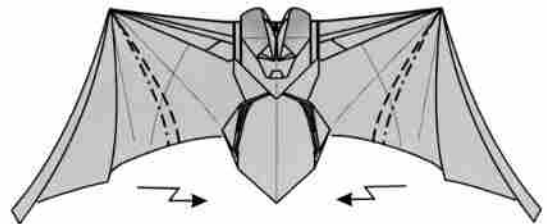

73.

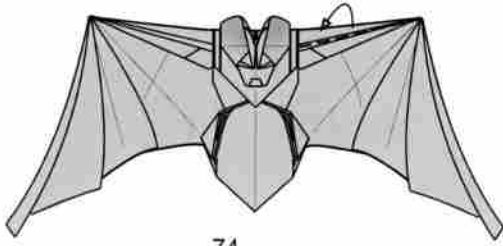

74.

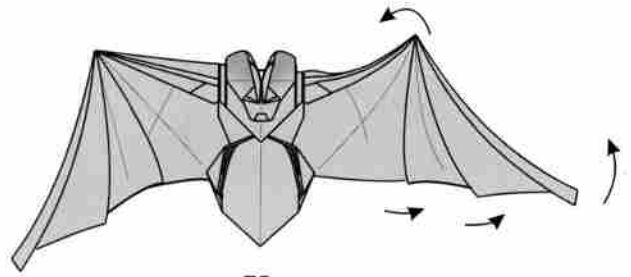

75

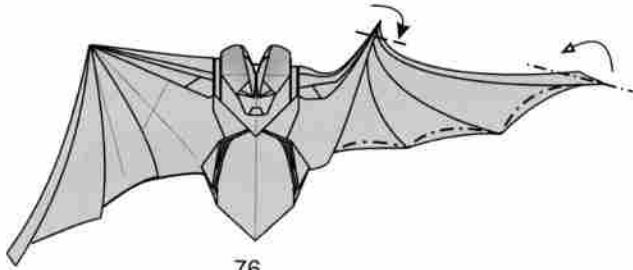

76.

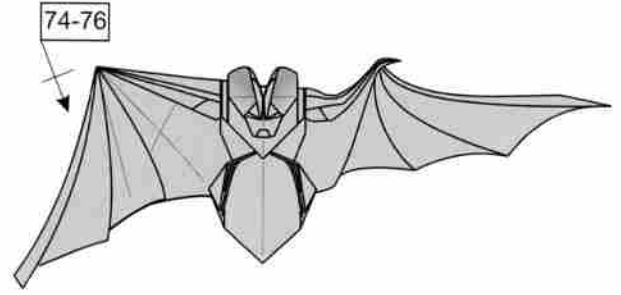

77. repeat on the left

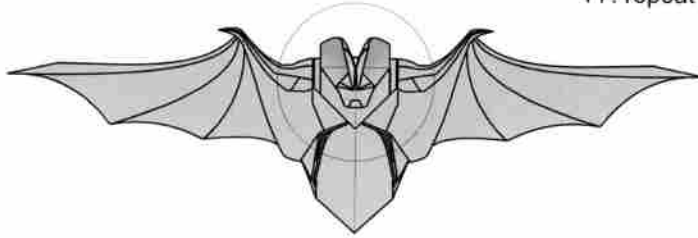

78. zoom in

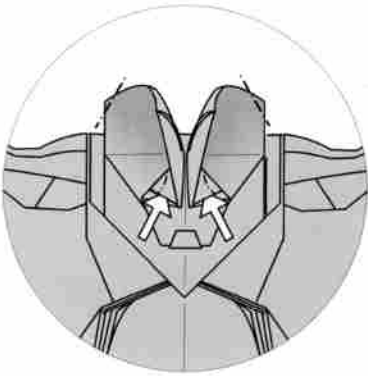

79.

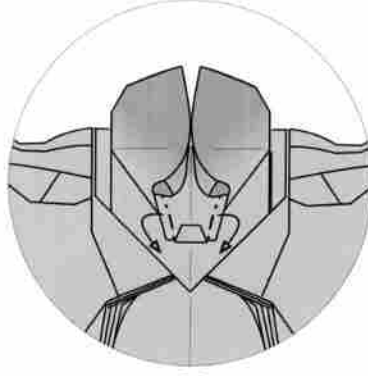

80.

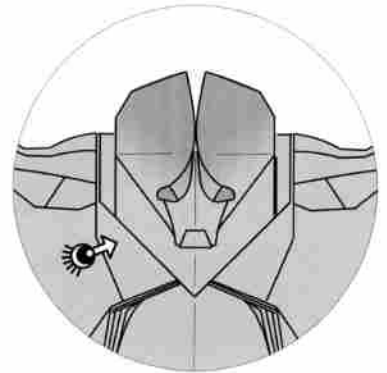

81.



82.



83.



84.



85.



86.



87.

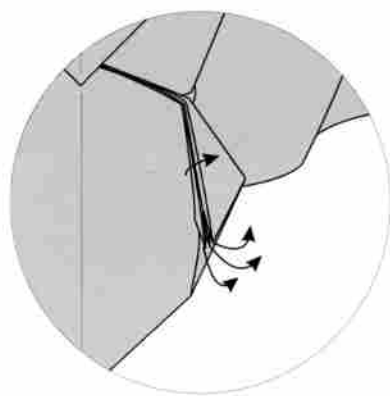

88. Fold and repeat on the left

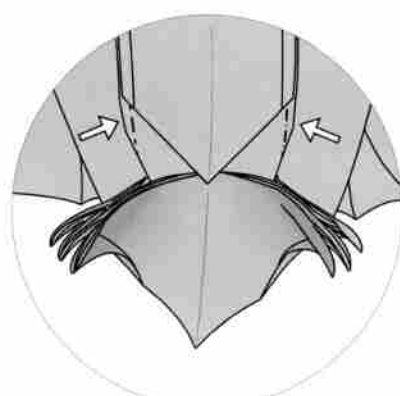

89.

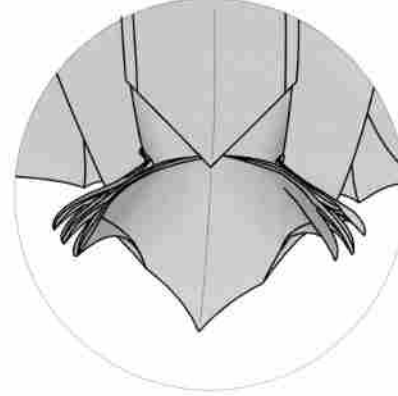

90.



91. Finished



# 학사모 Graduation Cap

by Lee JongSuk : Korea

Diagram by Lee JongSuk

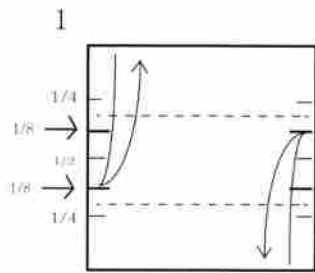

1/8선에 맞추어 접으세요

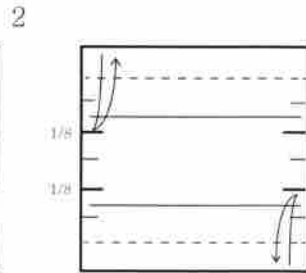

1/8선에 맞추어 네곳 모두 접으세요

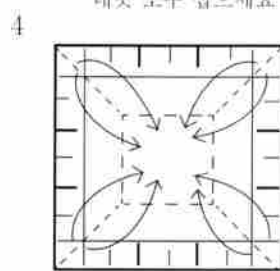
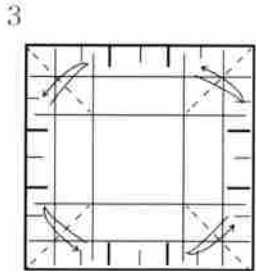

네곳을 접어서 5번이 되게 하세요

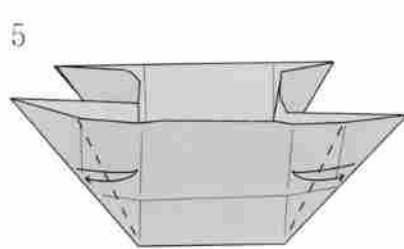

네곳 모두 접었다 펴세요

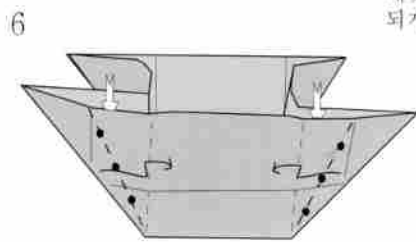

씩위 접기 하세요

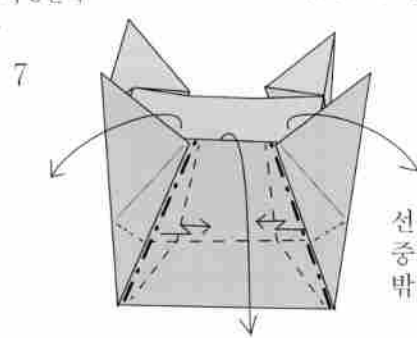

선을 잘 보고 8번처럼 중심으로 모으면서 윗부분을 밖으로 펼치세요

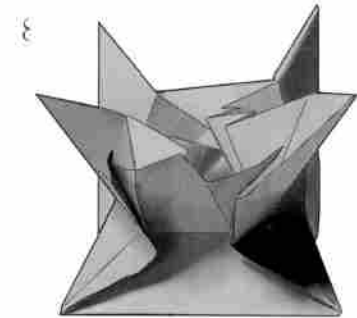

펼쳐지는 모습

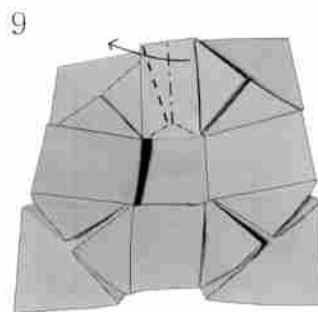

중심을 잡으며 옆으로 밀어 접으세요

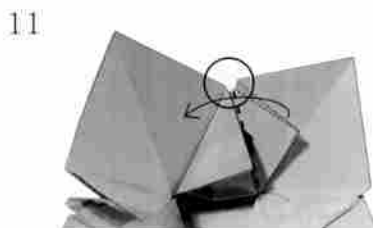
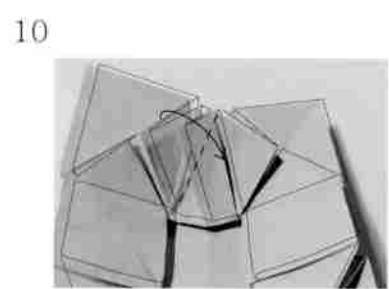

벌어지지 않게 살짝 겹치게 접어주세요



겹쳐진 부분을 뒤쪽으로 접어 넣으세요

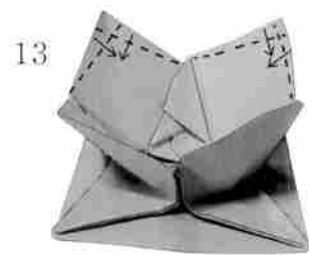

네곳 모두 접어주세요

# 카네이션 Carnation

by Yamaguchi Makoto : Japan

Diagram by Origami House

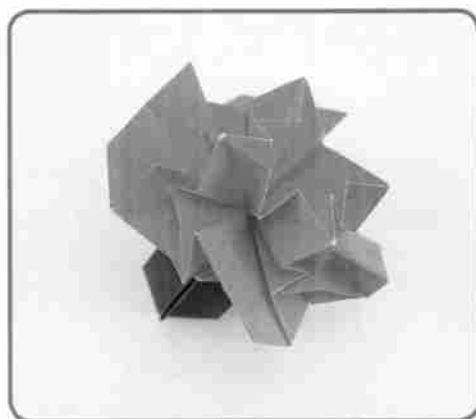

[花]

[紙の比率]

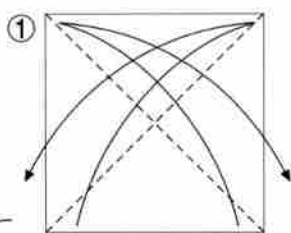

① 三角に折り筋をつける

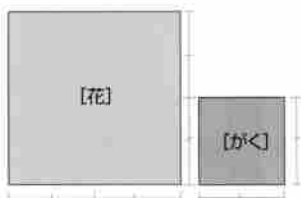

②

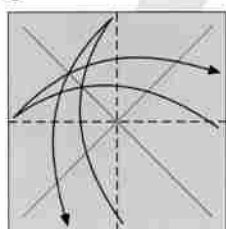

② 半分に折り筋をつける

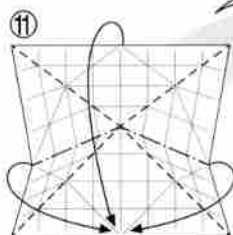

⑪ 途中の図

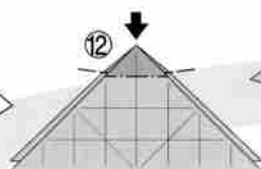

⑫ ついている折り筋で  
■の部分  
沈めるように折る

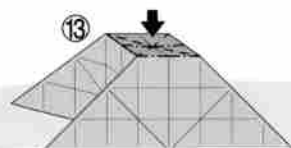

⑬ 途中の図

③

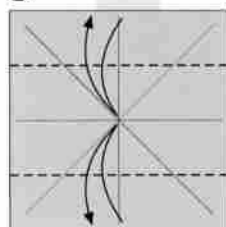

③ フチを折り筋に合わせて  
折り筋をつける

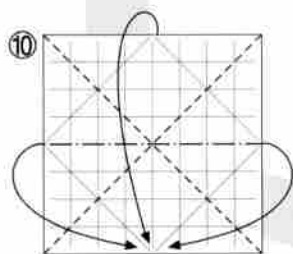

⑩ ついている折り筋で  
折りたむ

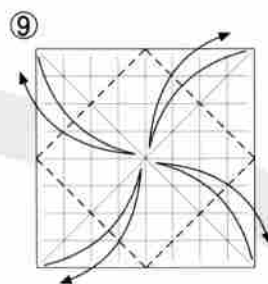

⑨ カドを中心に  
合わせて  
折り筋をつける

④

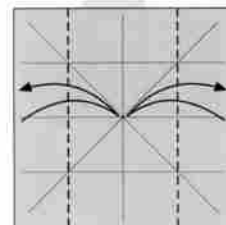

④ フチを折り筋に合わせて  
折り筋をつける

⑧

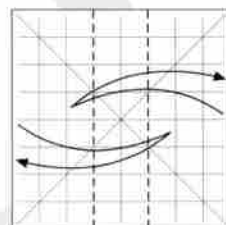

⑧ フチを折り筋に合わせて  
折り筋をつける

⑤

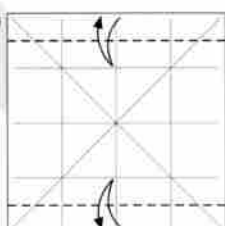

⑤ フチを  
折り筋に合わせて  
折り筋をつける

⑥

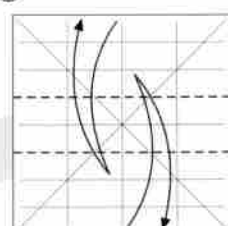

⑥ フチを折り筋に合わせて  
折り筋をつける

⑦

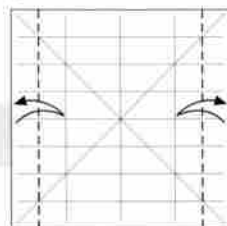

⑦ フチを折り筋に合わせて  
折り筋をつける

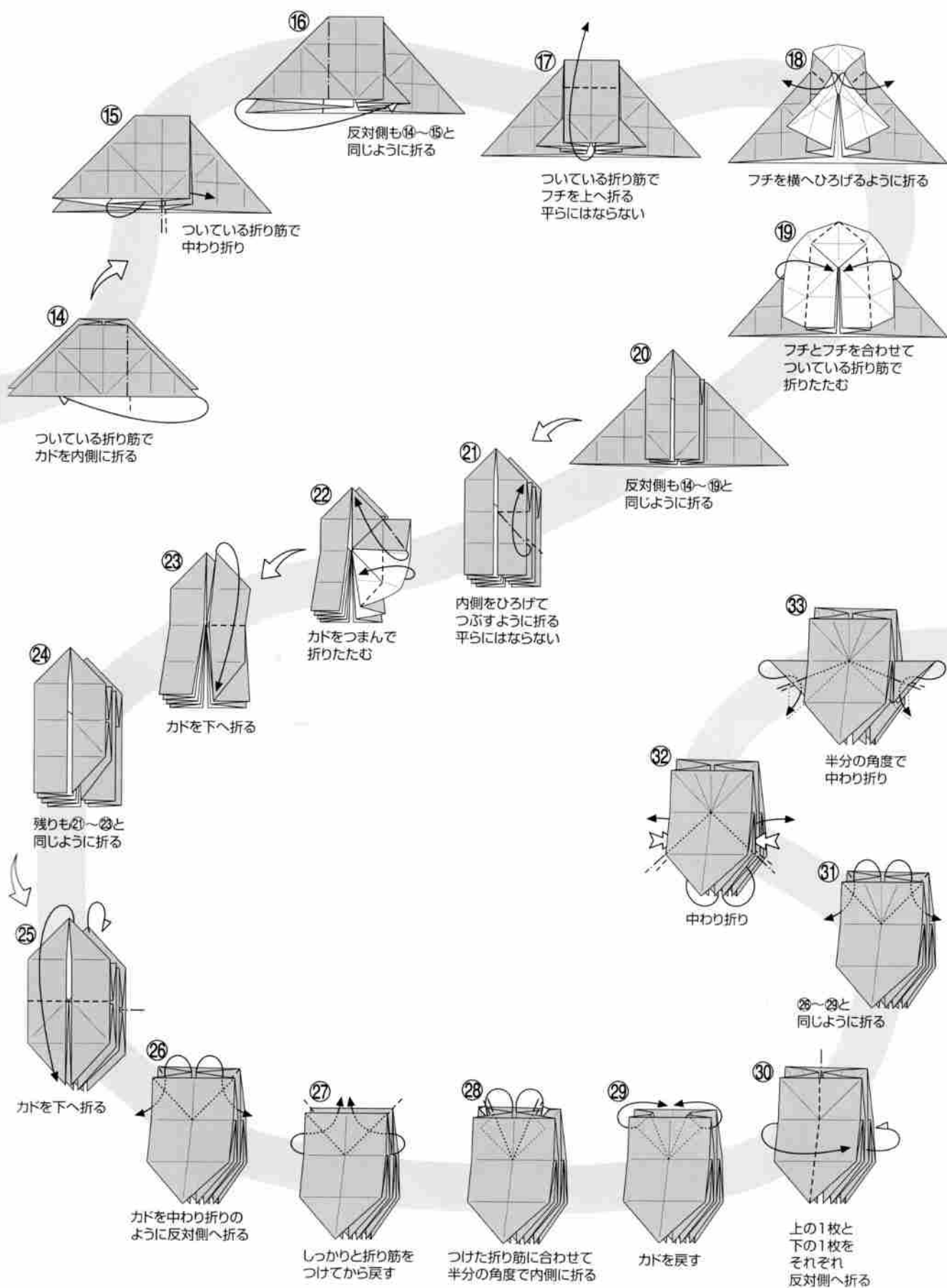

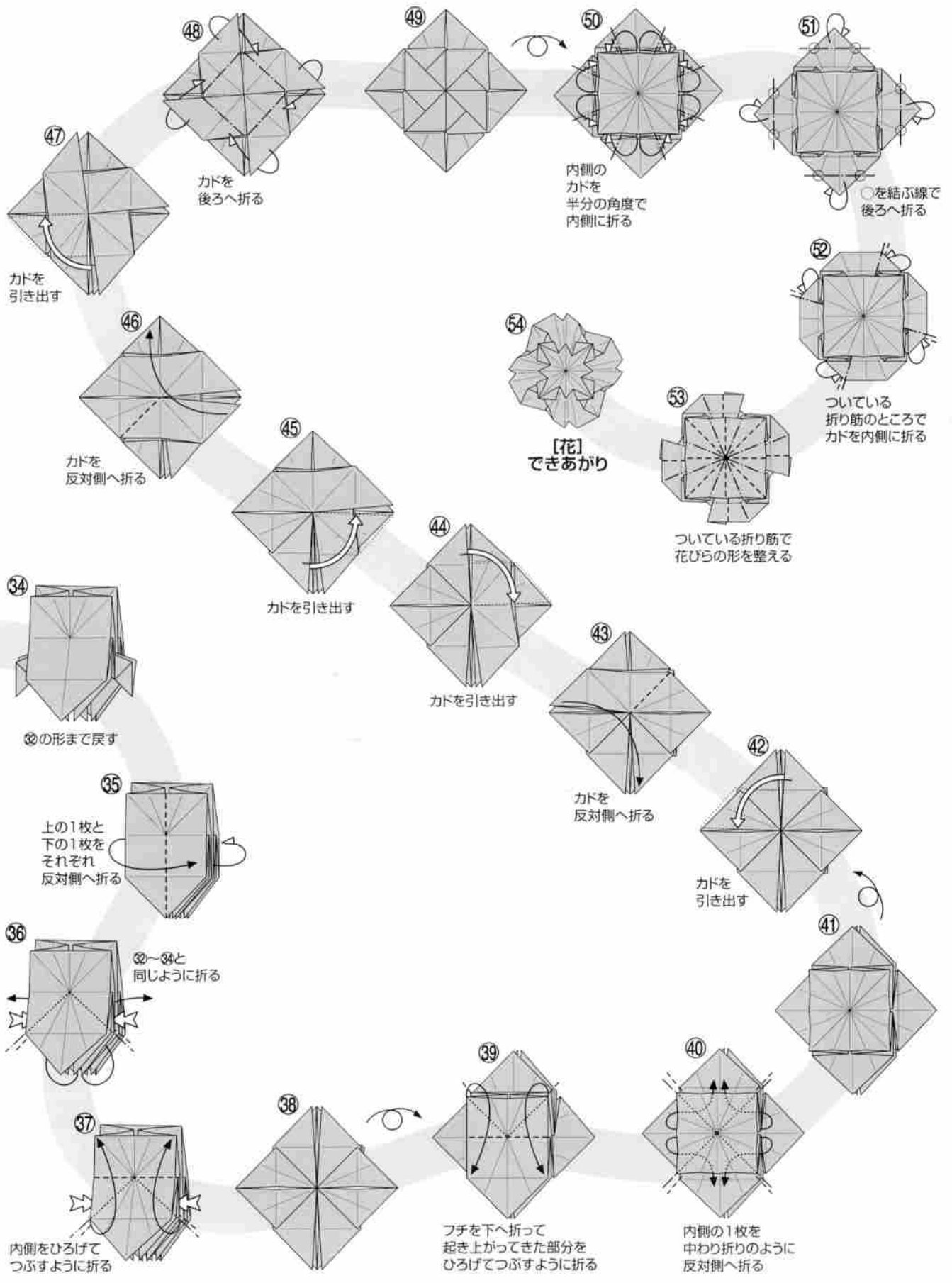

[かく]

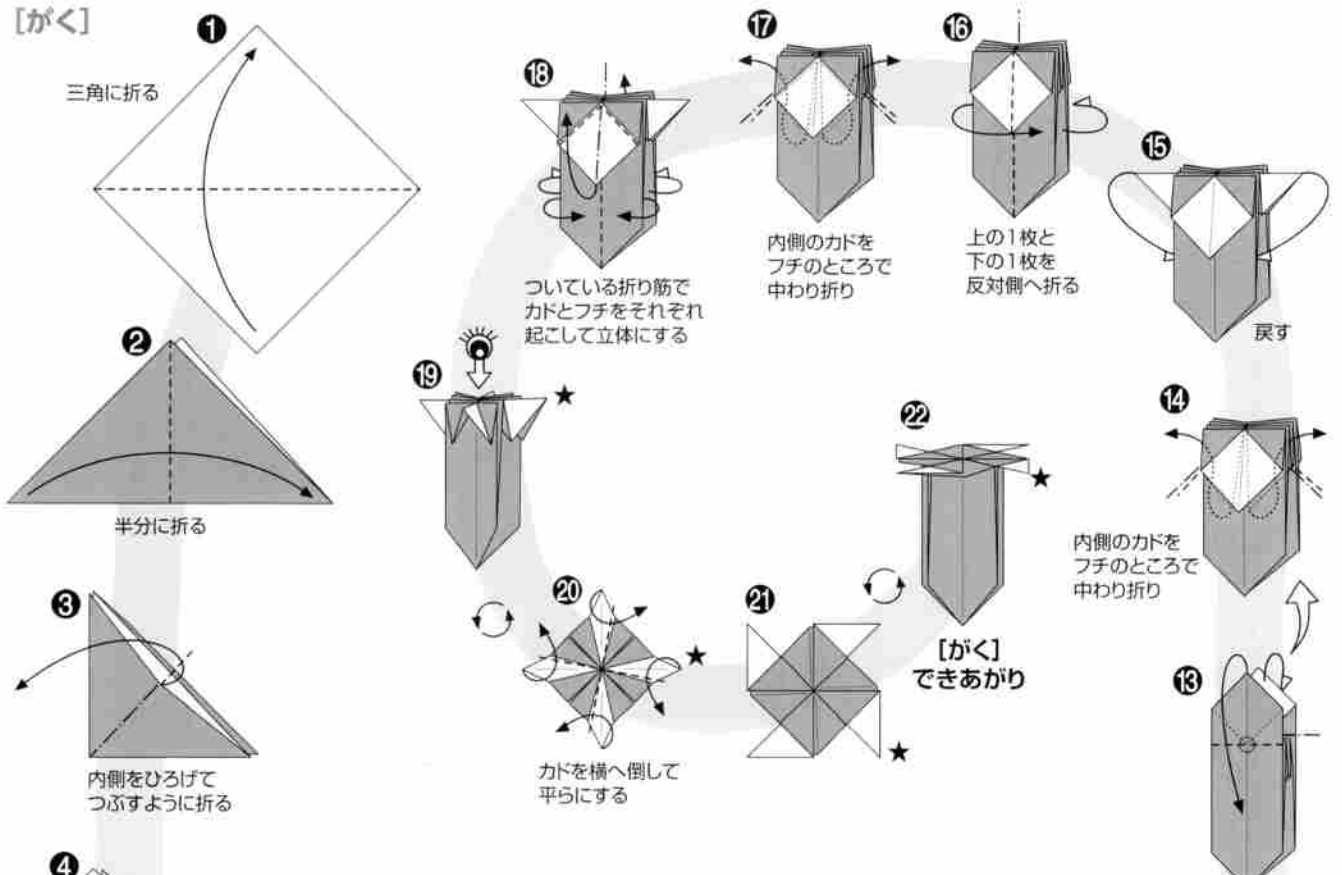

[組み立て方]

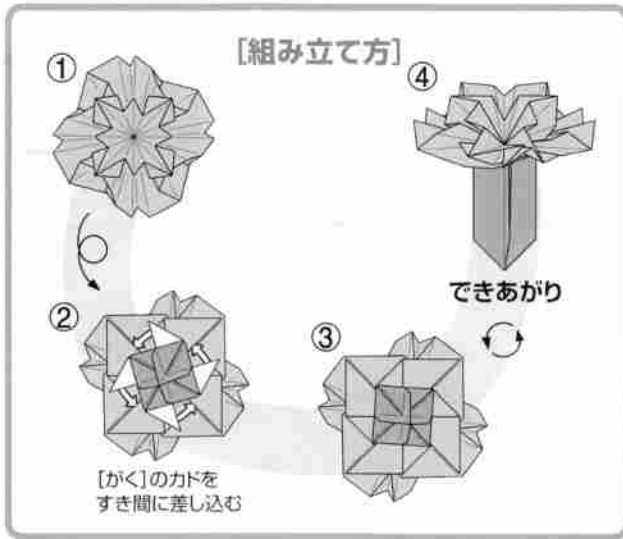

# Gear Cube

by Miyuki Kawamura : Japan

Diagram by Miyuki Kawamura

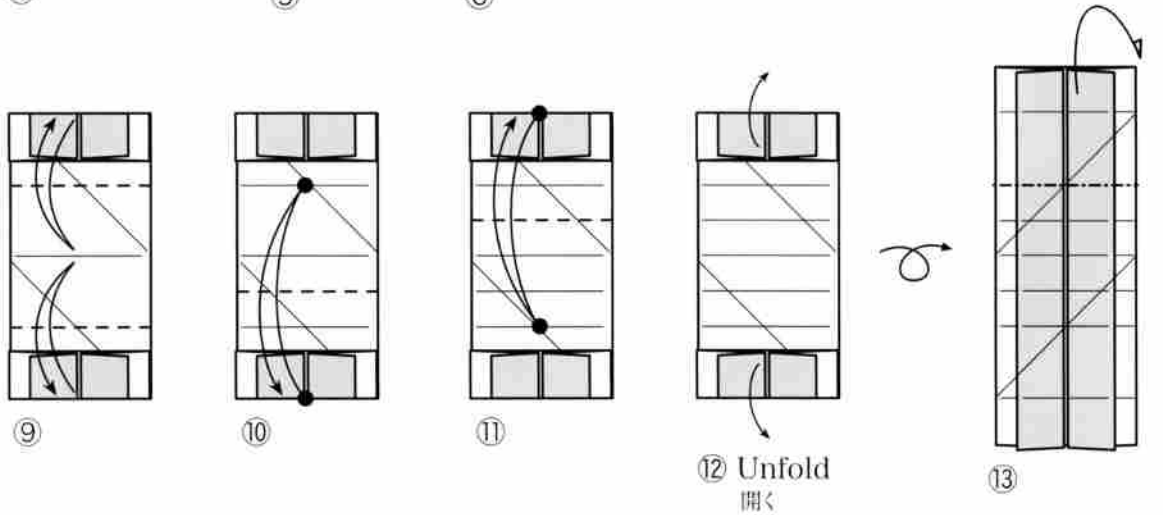
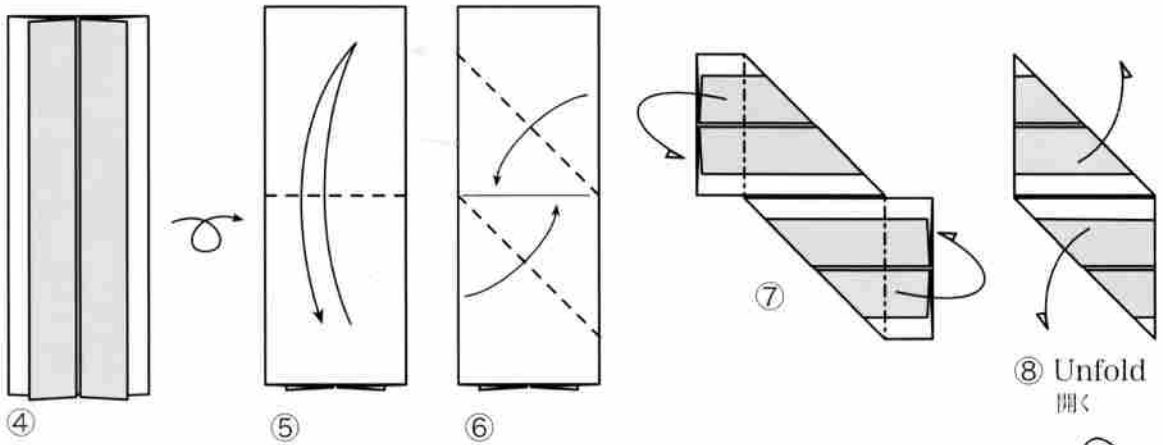
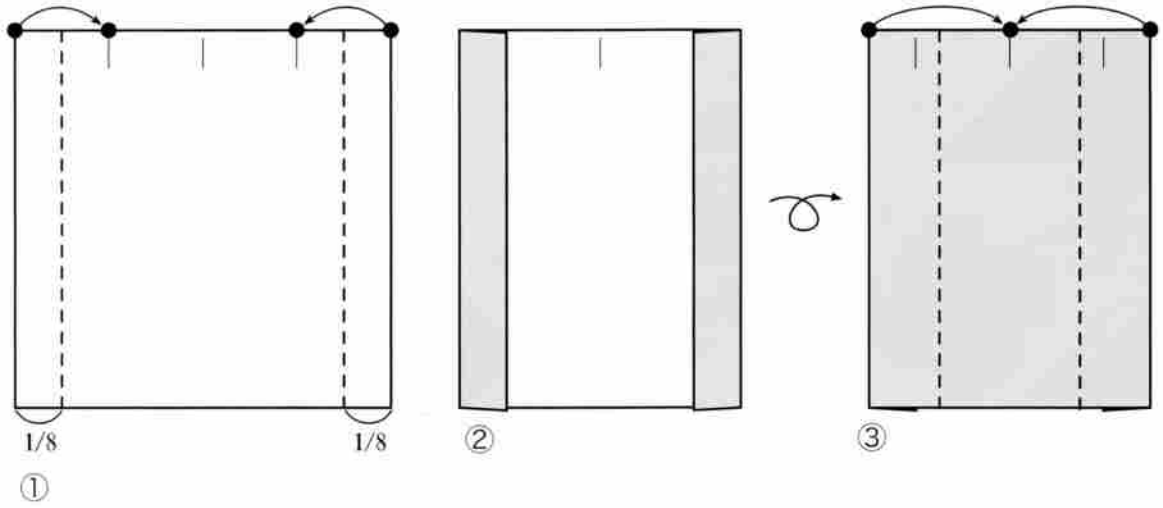
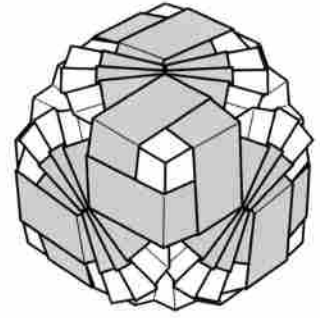

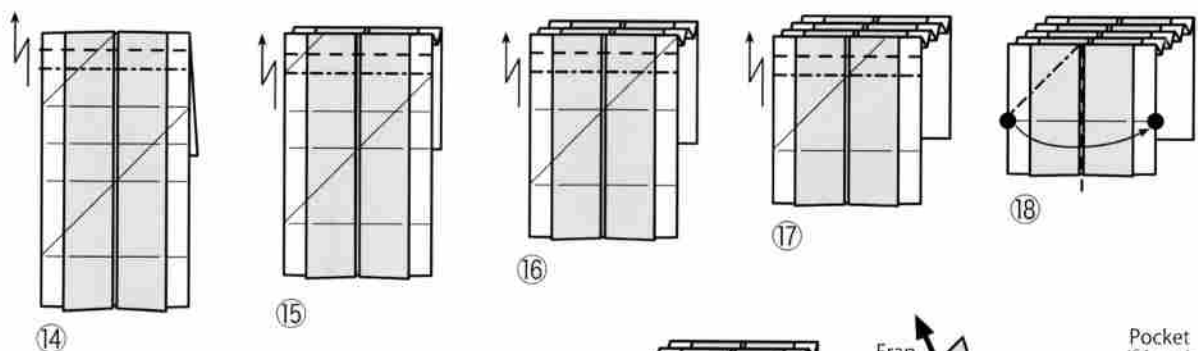

14

15

16

17

18

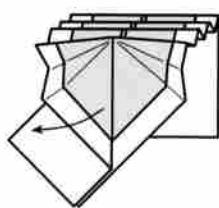

19 Unfold  
開く

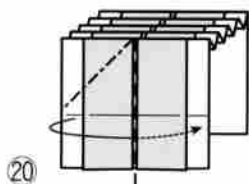

20 Fold and insert the left side flap under the right side pocket.  
左側を引き寄せて、右側の下に入れる

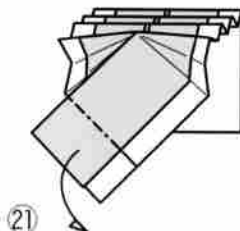

21 Fold the flap. Do the same steps 18 - 21 on the opposite side.  
フラップを折る。反対側も18~21と同じように折る。

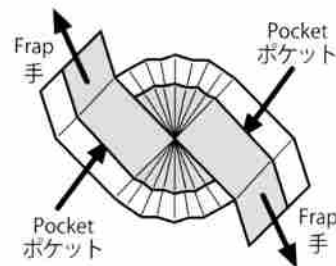

The GEAR CUBE module  
「ギア・キューブ」のユニット  
You need 6 modules.  
同じものを6個作ります

### Variation

バリエーション

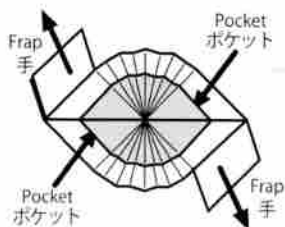

6 modules  
6枚組

### Assembly

組み方

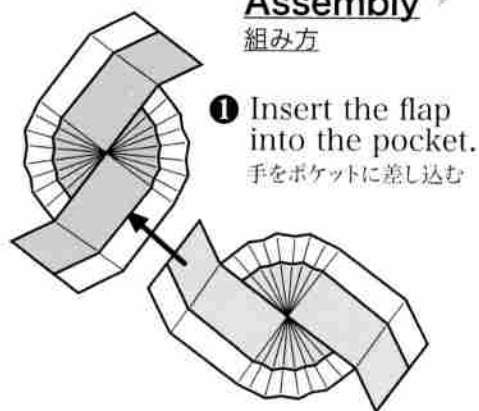

1 Insert the flap into the pocket.  
手をポケットに差し込む

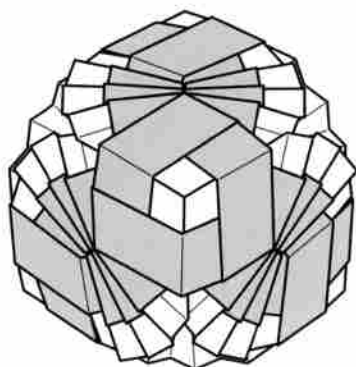

### GEAR CUBE

ギア・キューブ  
6 modules model  
6枚組

2 Add the other modules in the same way to make a cube.  
残りのユニットも同様に組んで立方体の形にする。

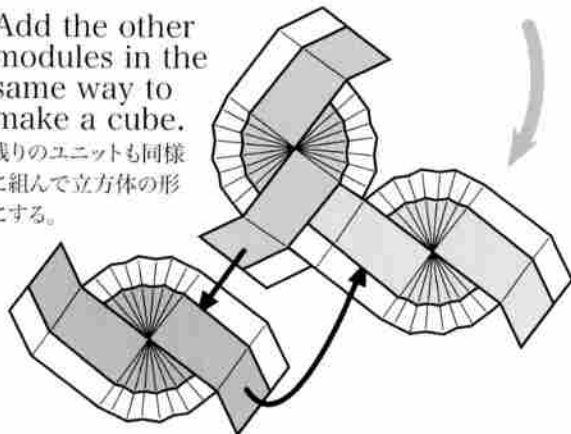

# Erizo purpura purple sea urchin

by Manuel Sirgo : Spain

Diagram by Manuel Sirgo

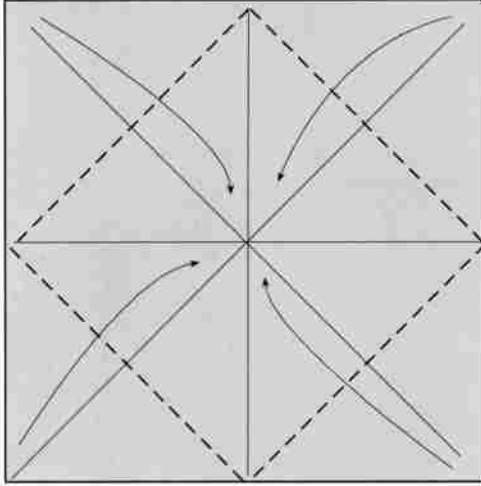

1  Púrpura, Purple

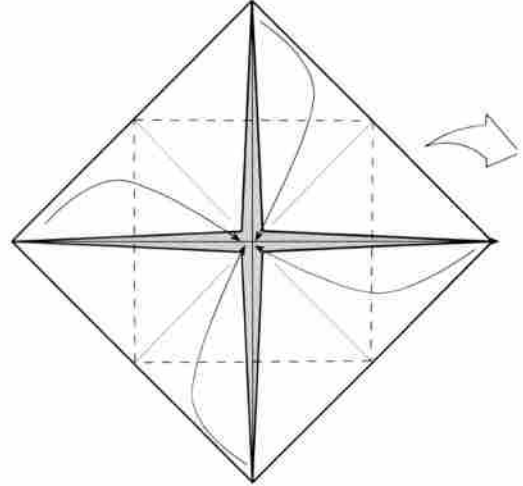

2

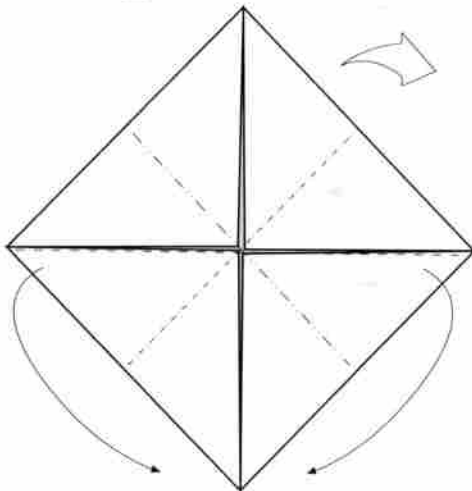

3

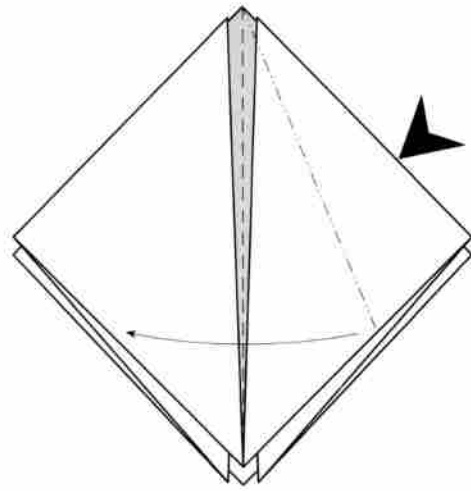

4

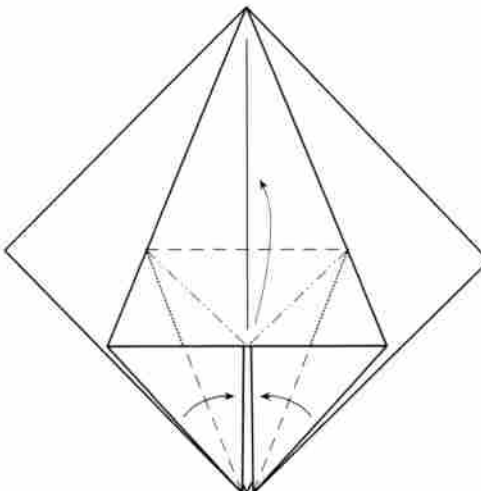

5

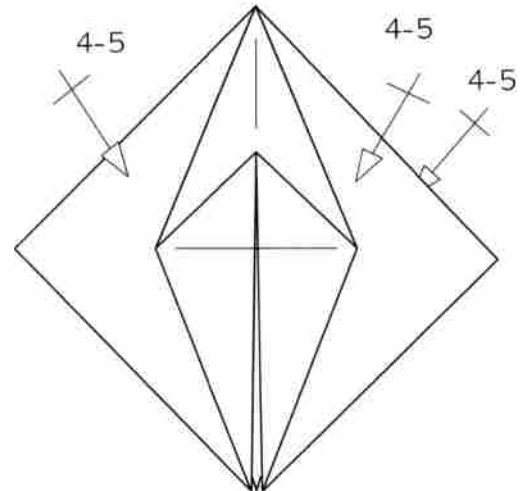

6



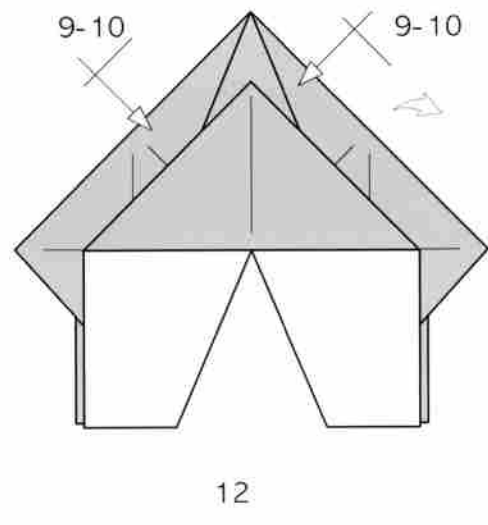
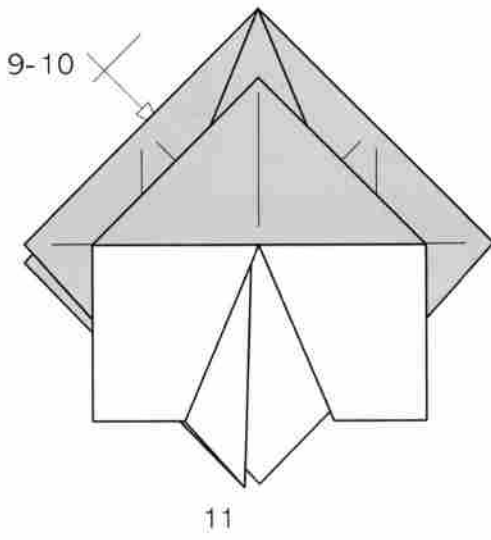
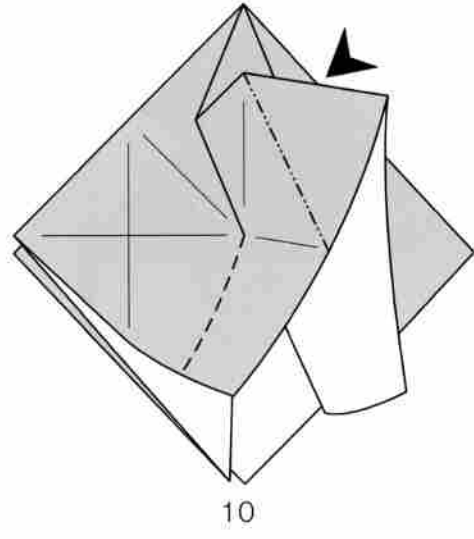
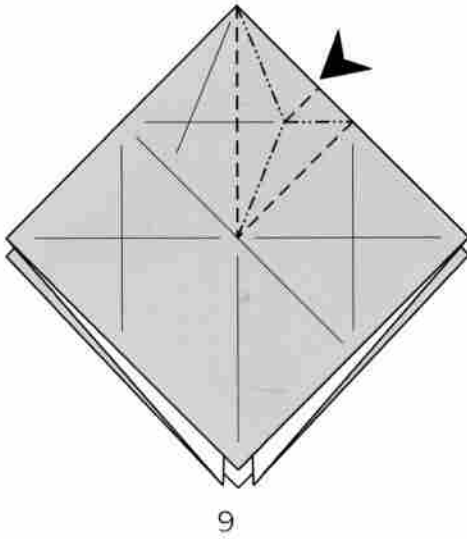
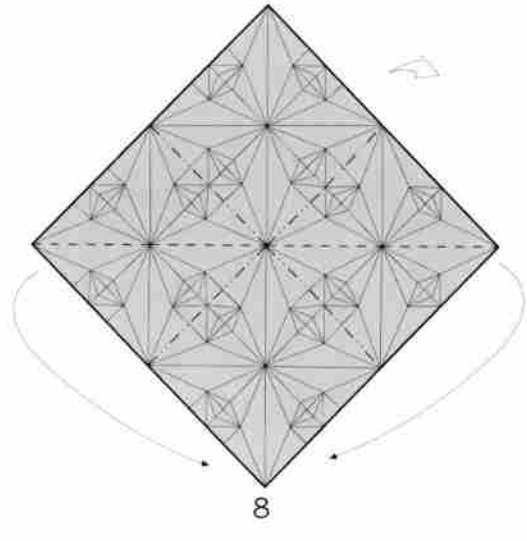
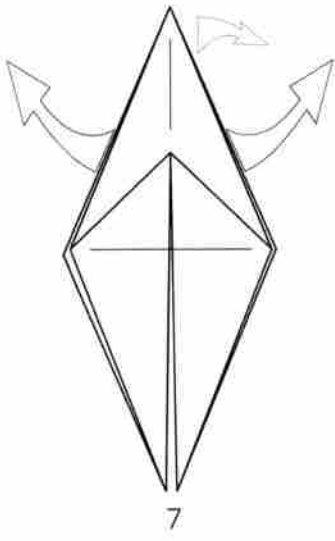

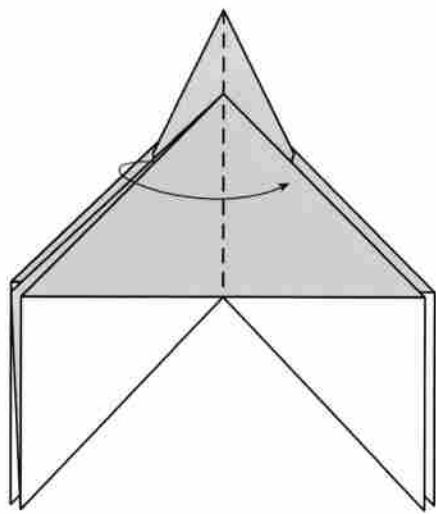

13

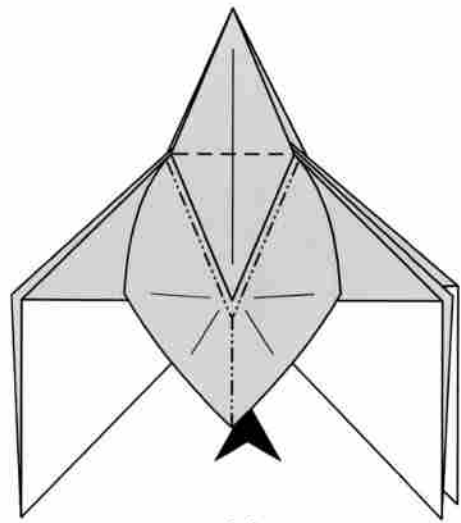

14

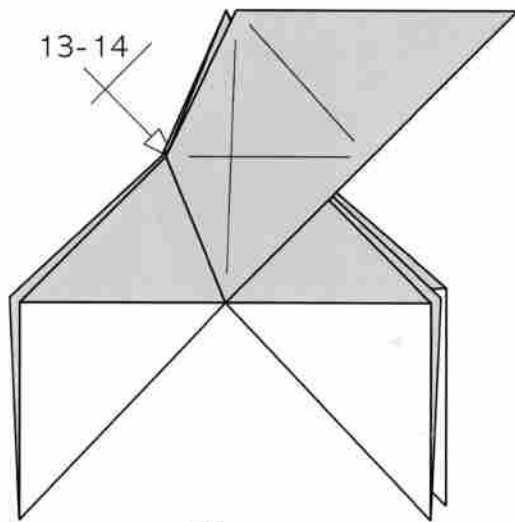

15

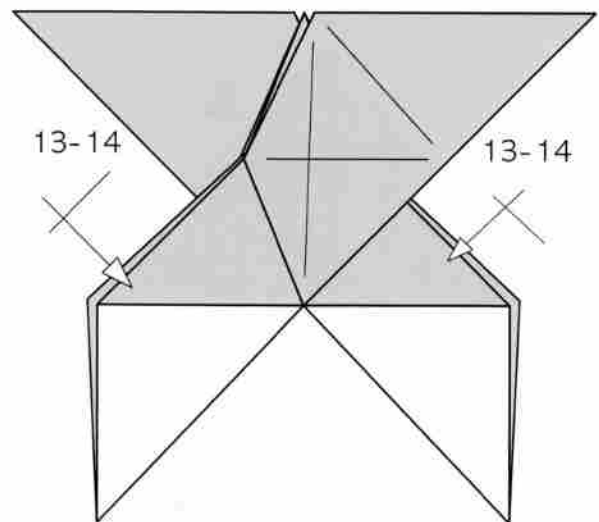

16

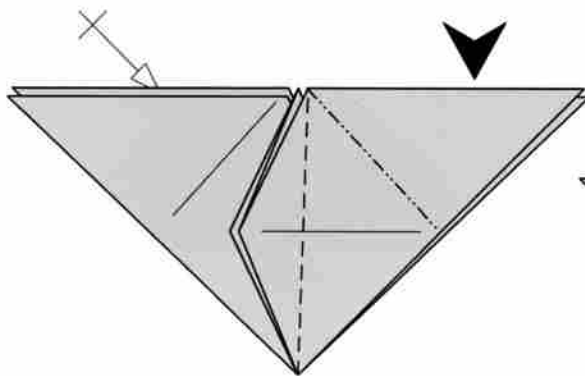

17

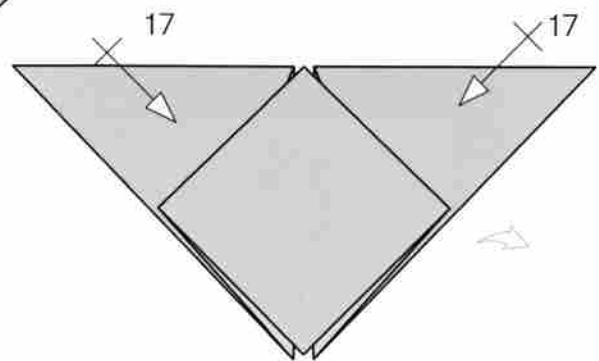

18

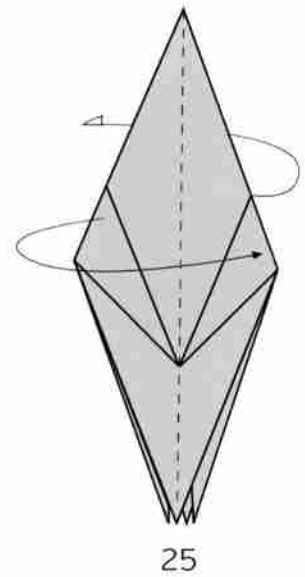
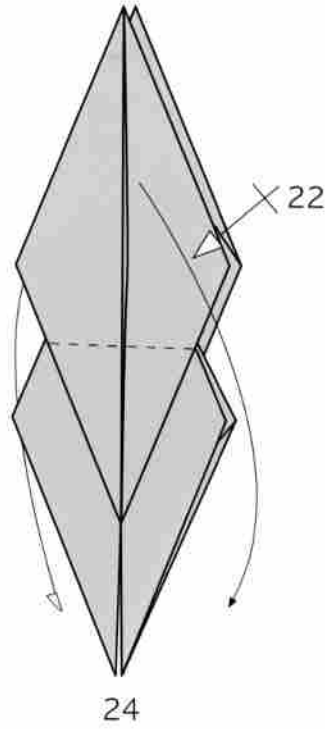
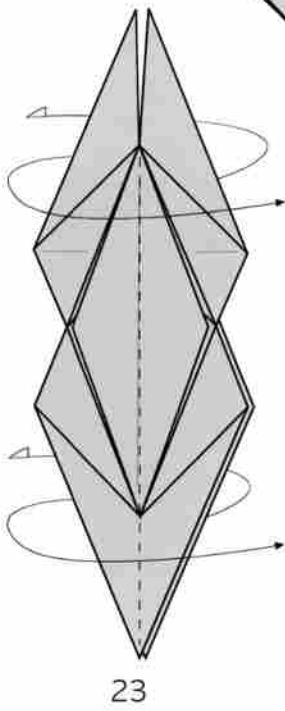
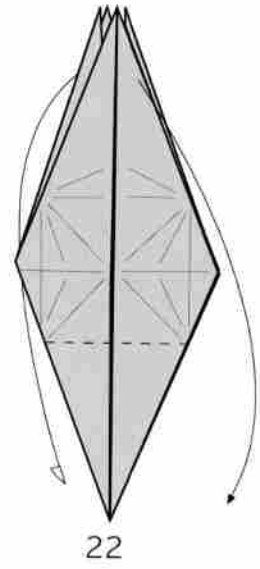
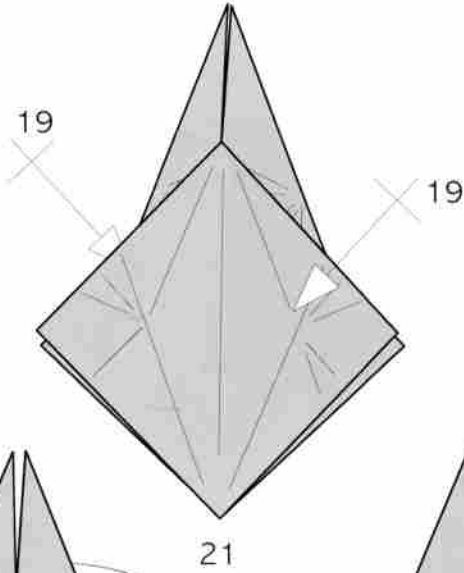
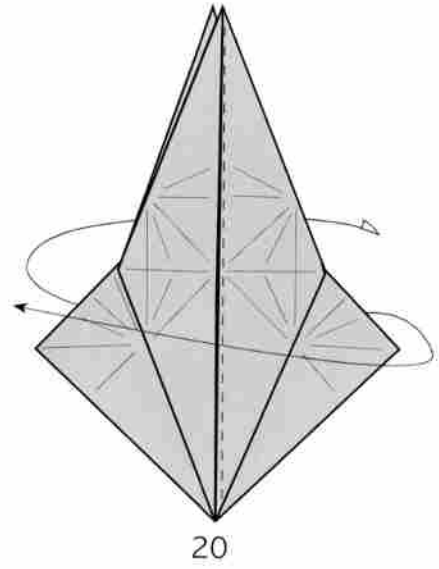
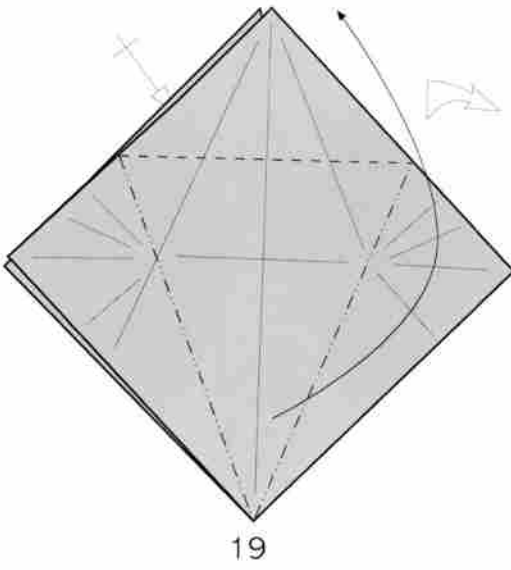

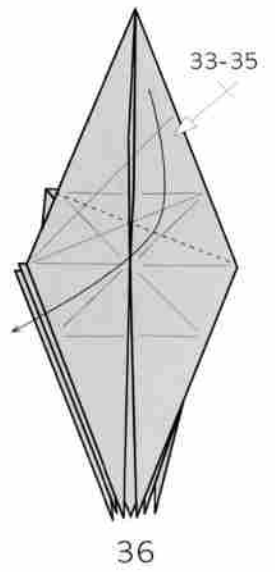
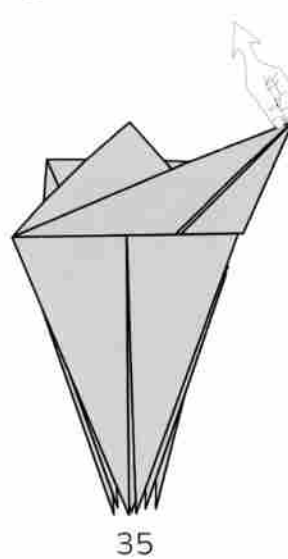
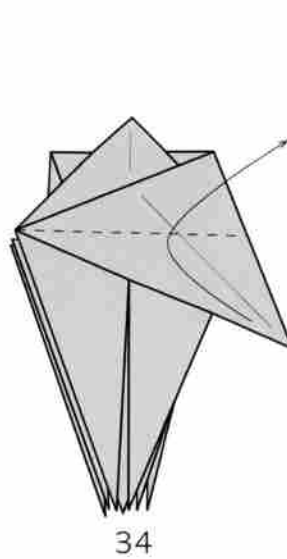
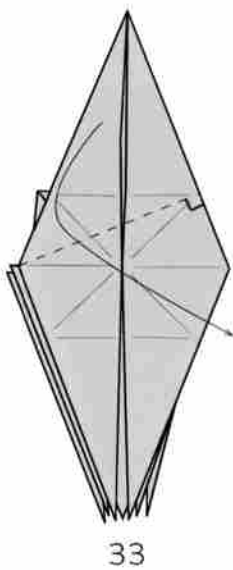
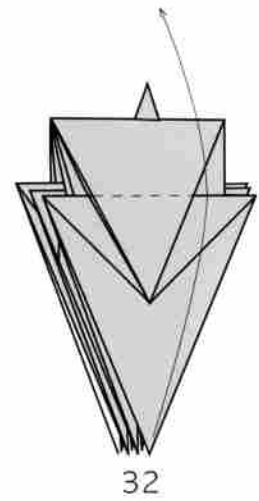
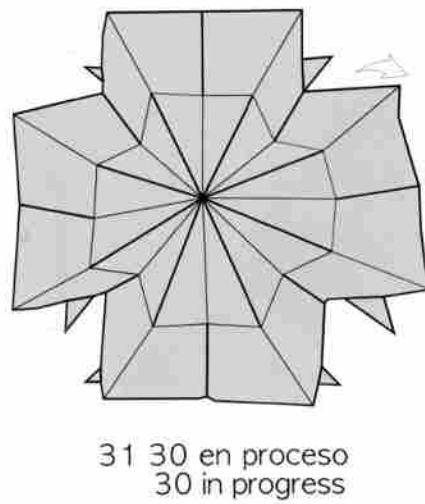
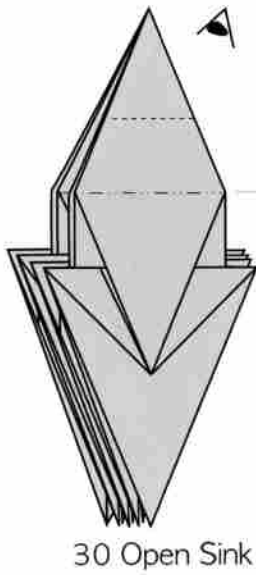
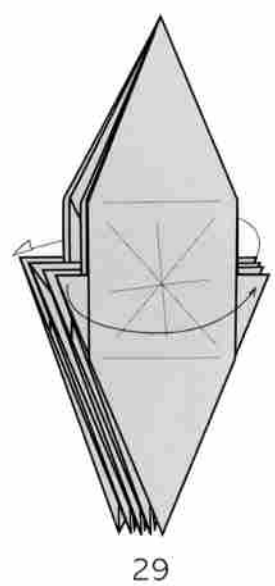
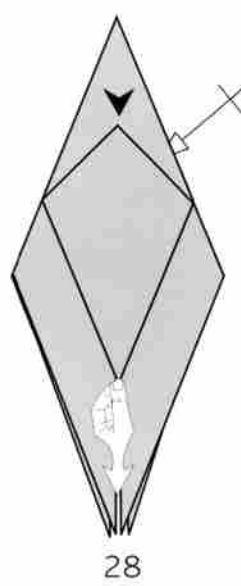
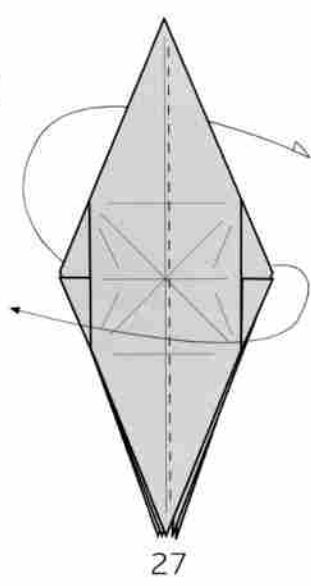
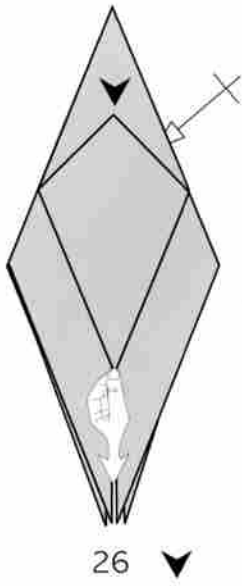

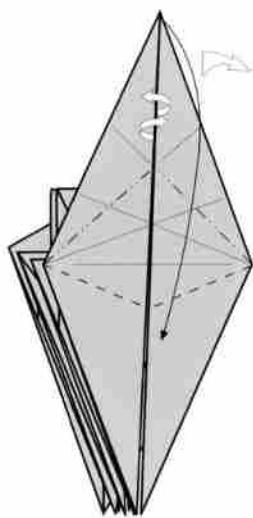

37

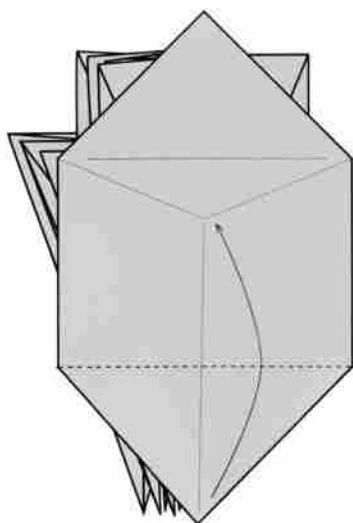

38

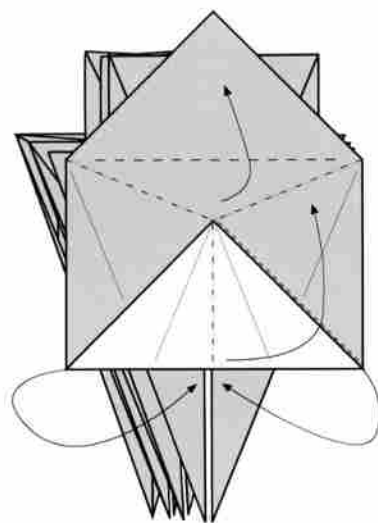

39

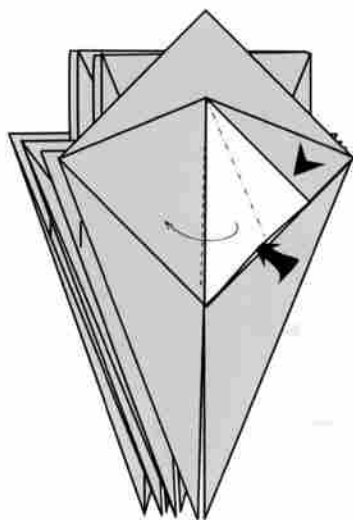

40

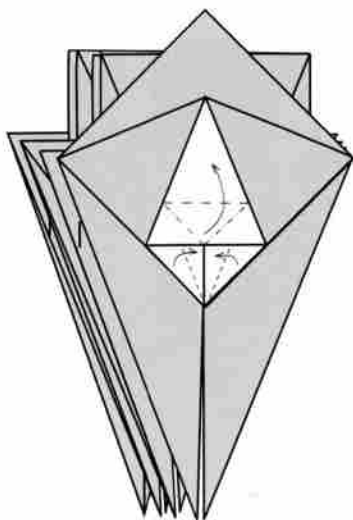

41

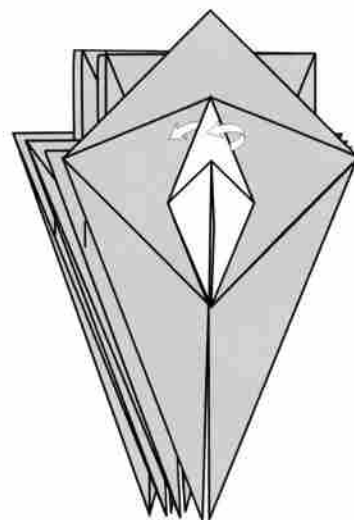

42

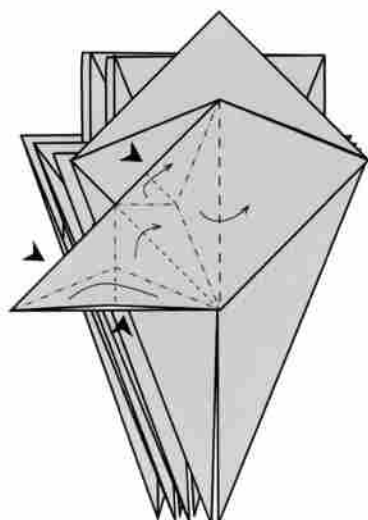

43

32-43

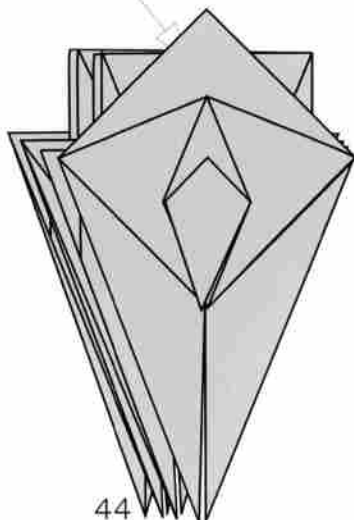

44

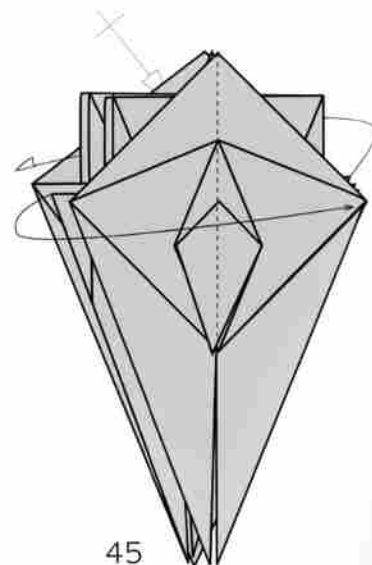

45

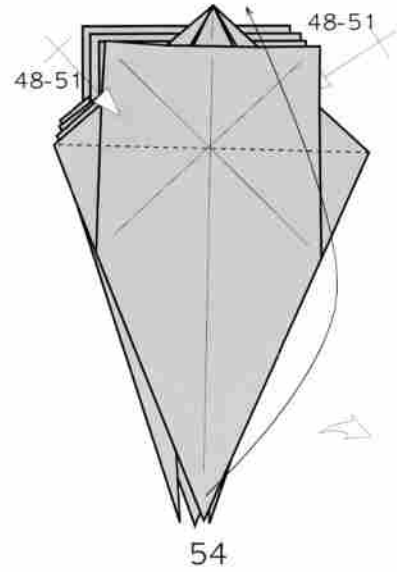
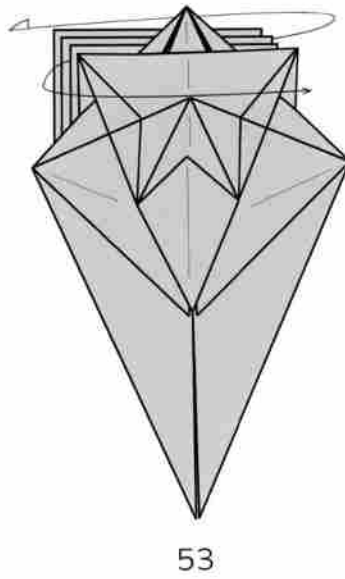
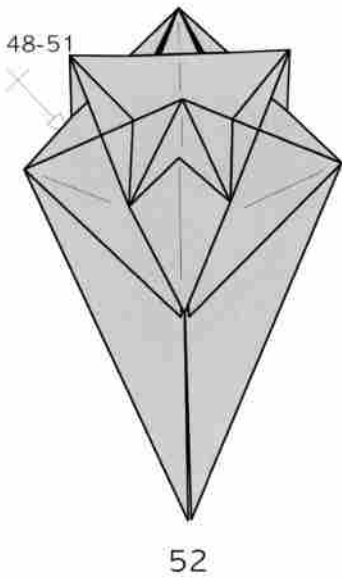
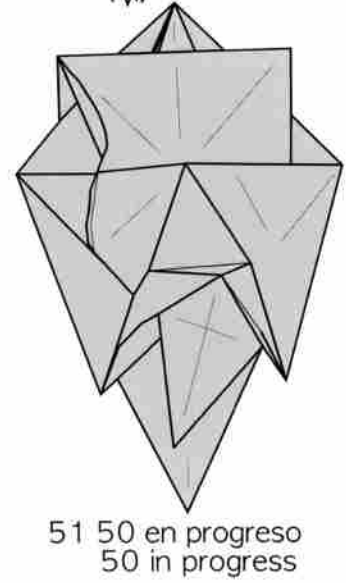
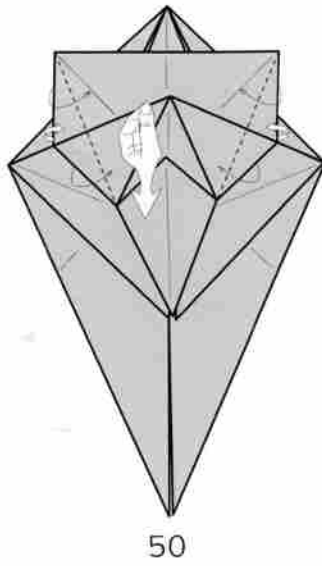
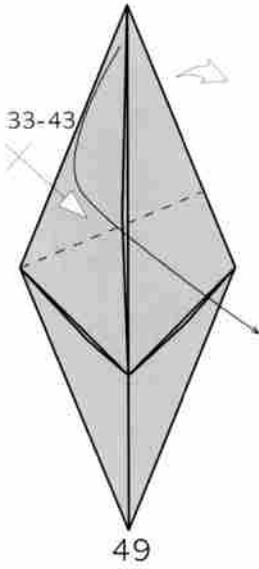
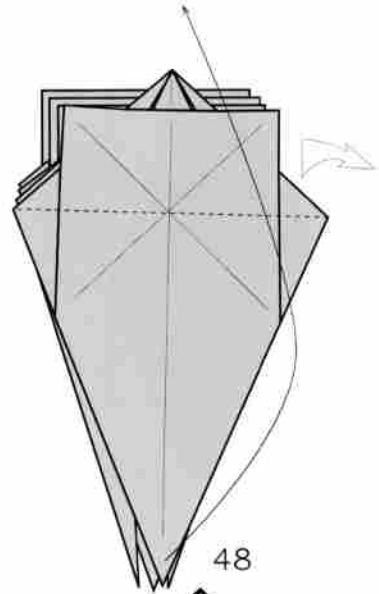
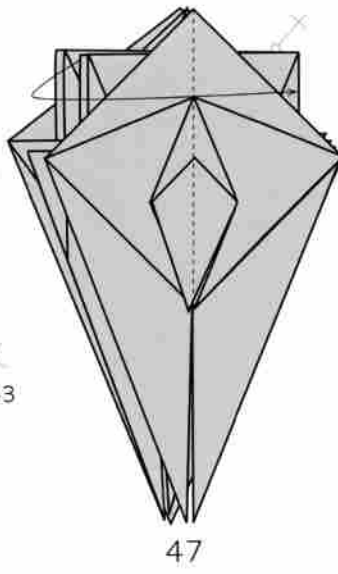
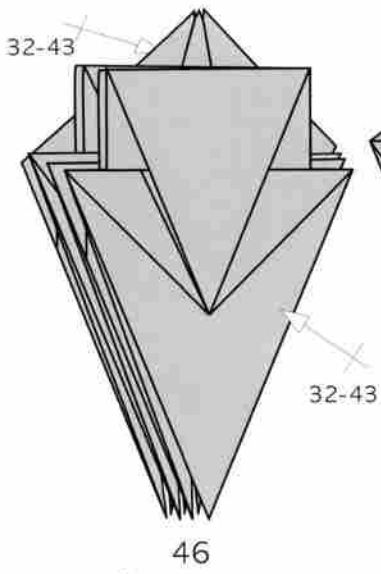

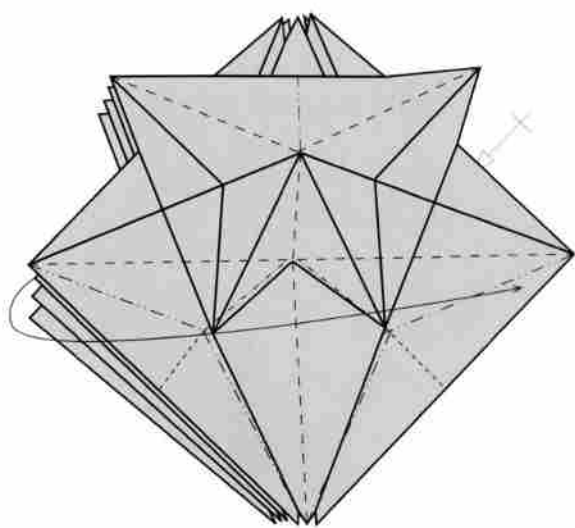

55

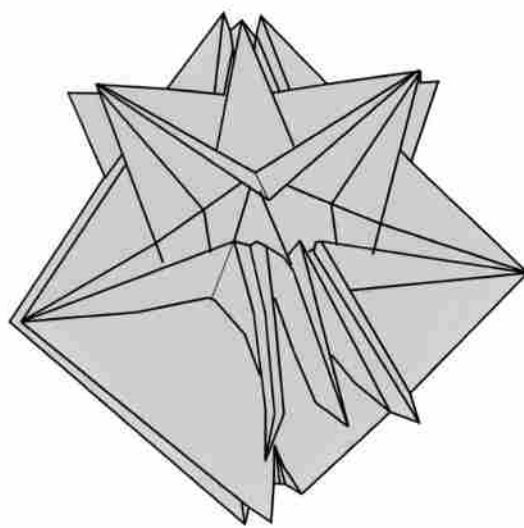

56 55 en progreso  
55 in progress

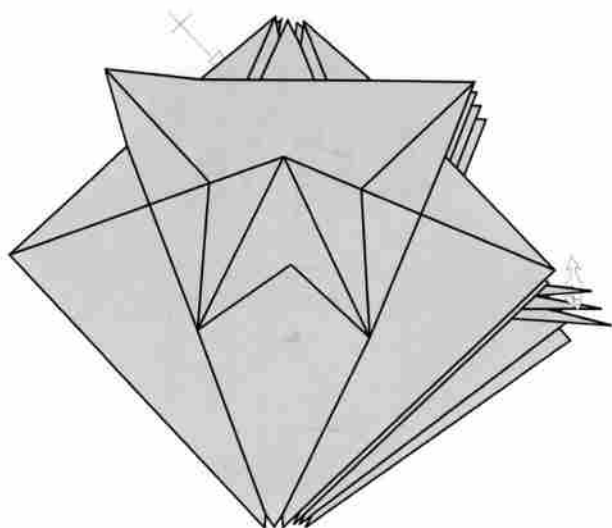

57 Deslizar la punta  
Slide the tip

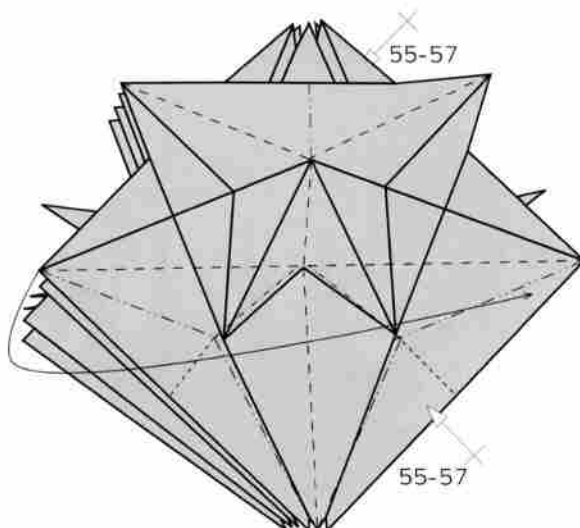

58

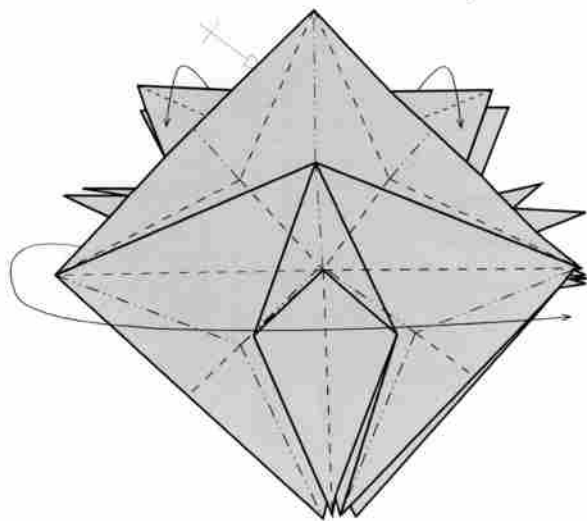

59



60 59 en progreso  
59 in progress

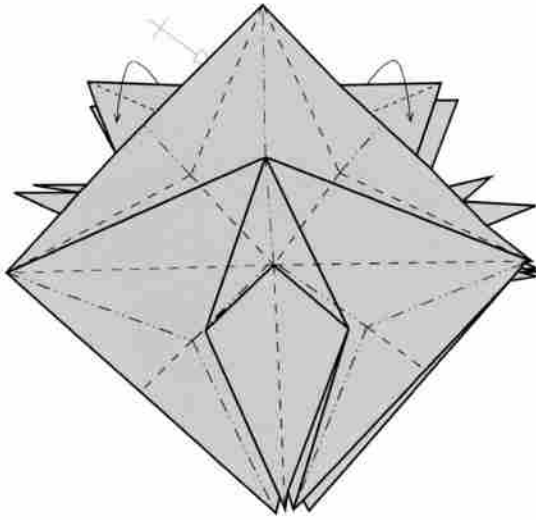

61 Deslizar y orientar todas las puntas.  
El modelo no puede ponerse plano.  
Slide and orient all the tips.  
The model can not be flat.



61 Modelo acabado  
Finished model

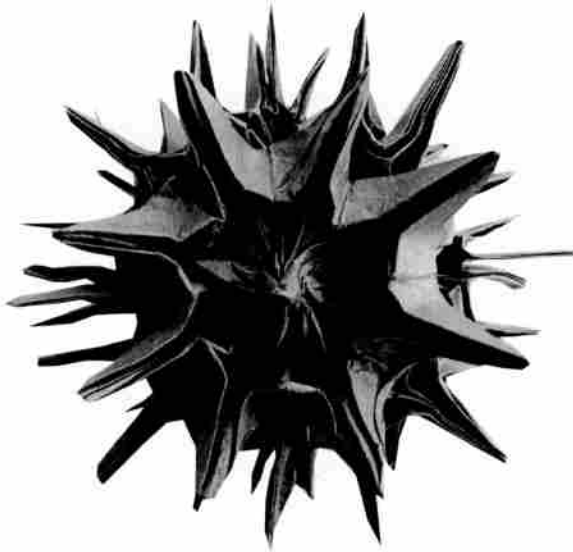

Vista su perior  
Top view



Vista inferior  
Bottom view



# Sundrop Flower

by Jesus Artigas Villanueva : Spain

Diagram by Jesus Artigas Villanueva

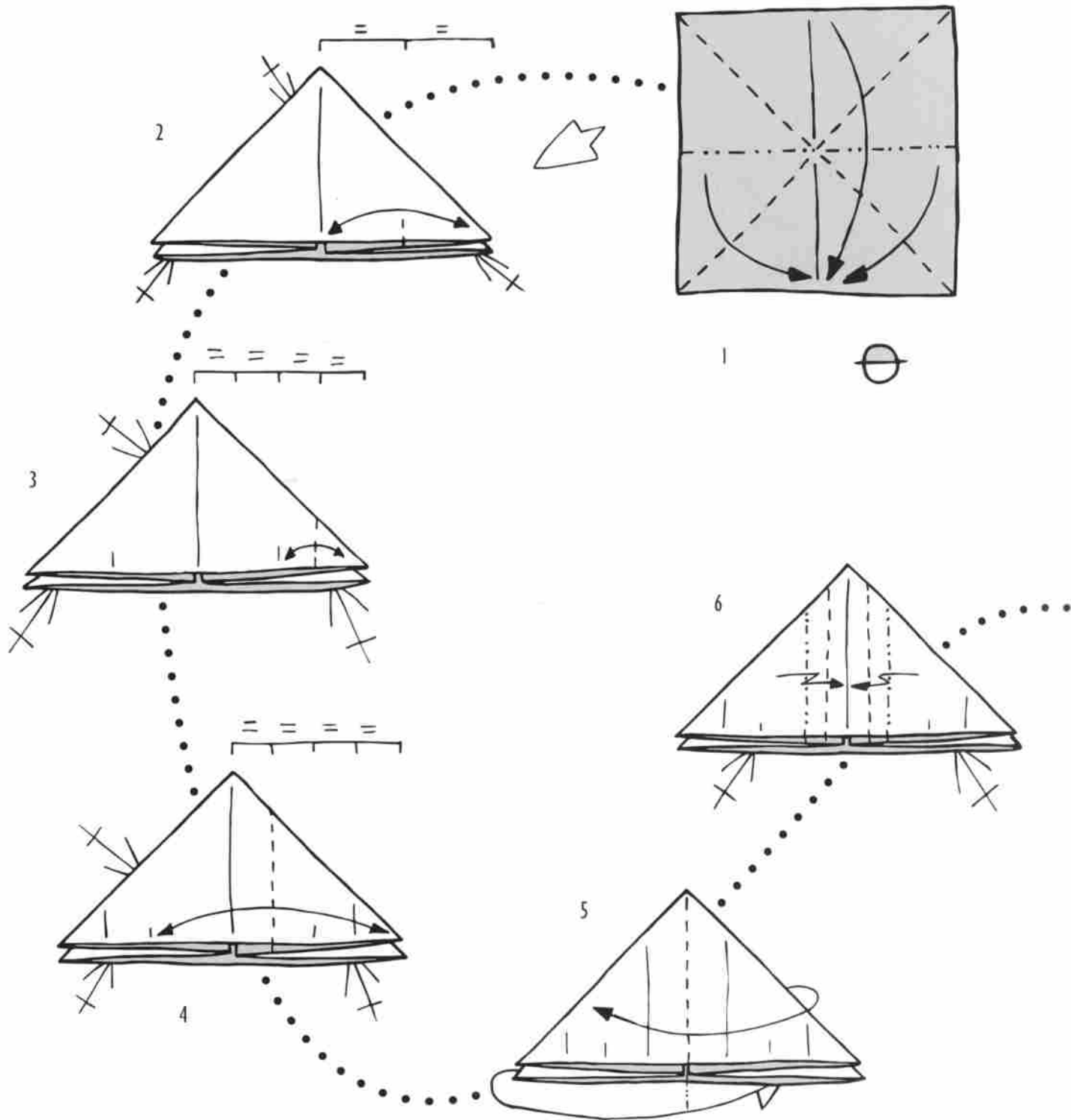
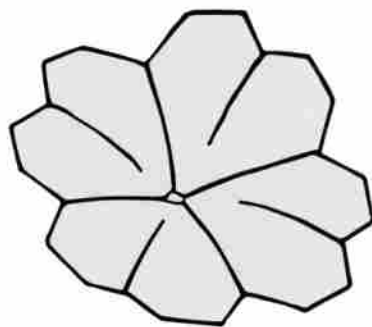

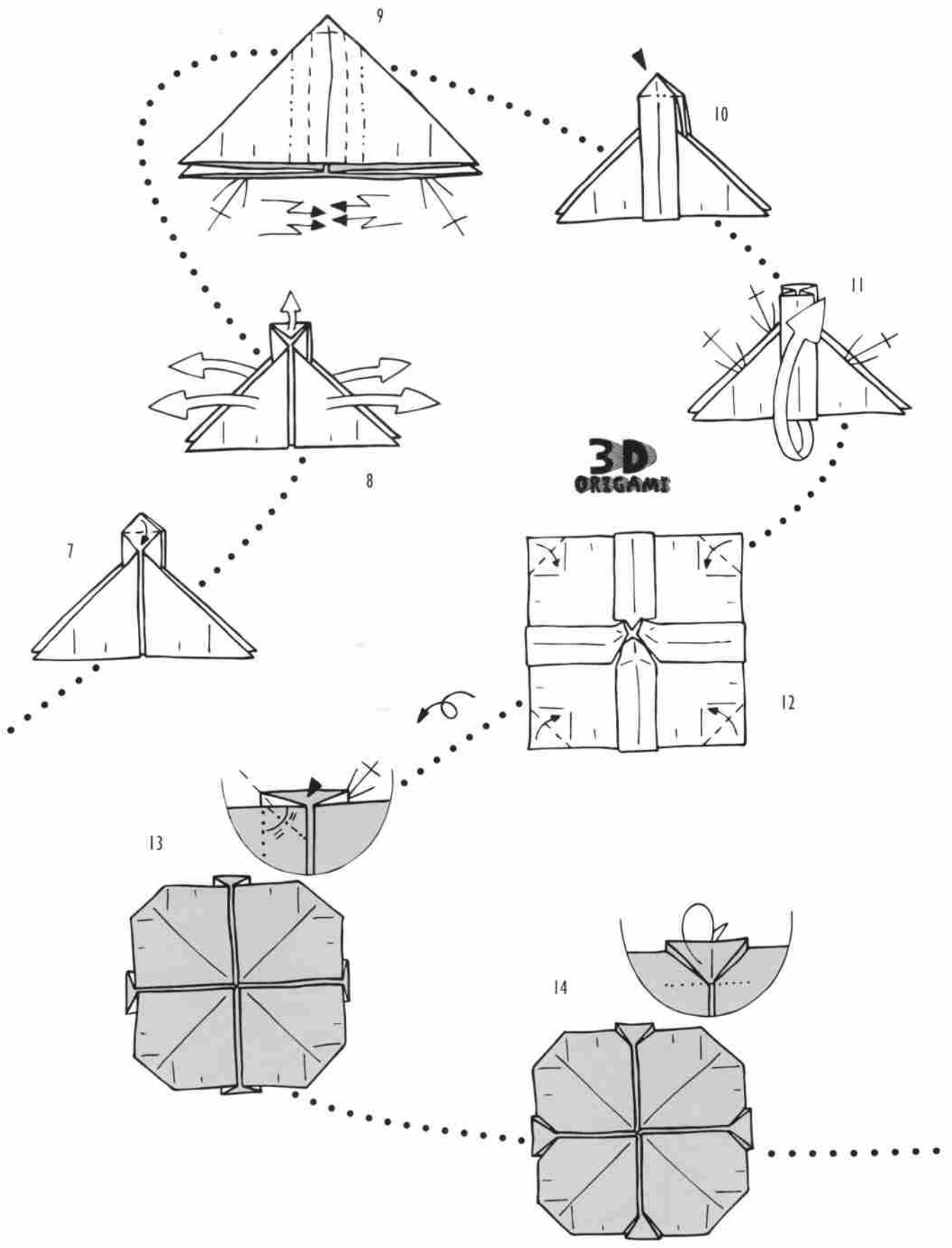

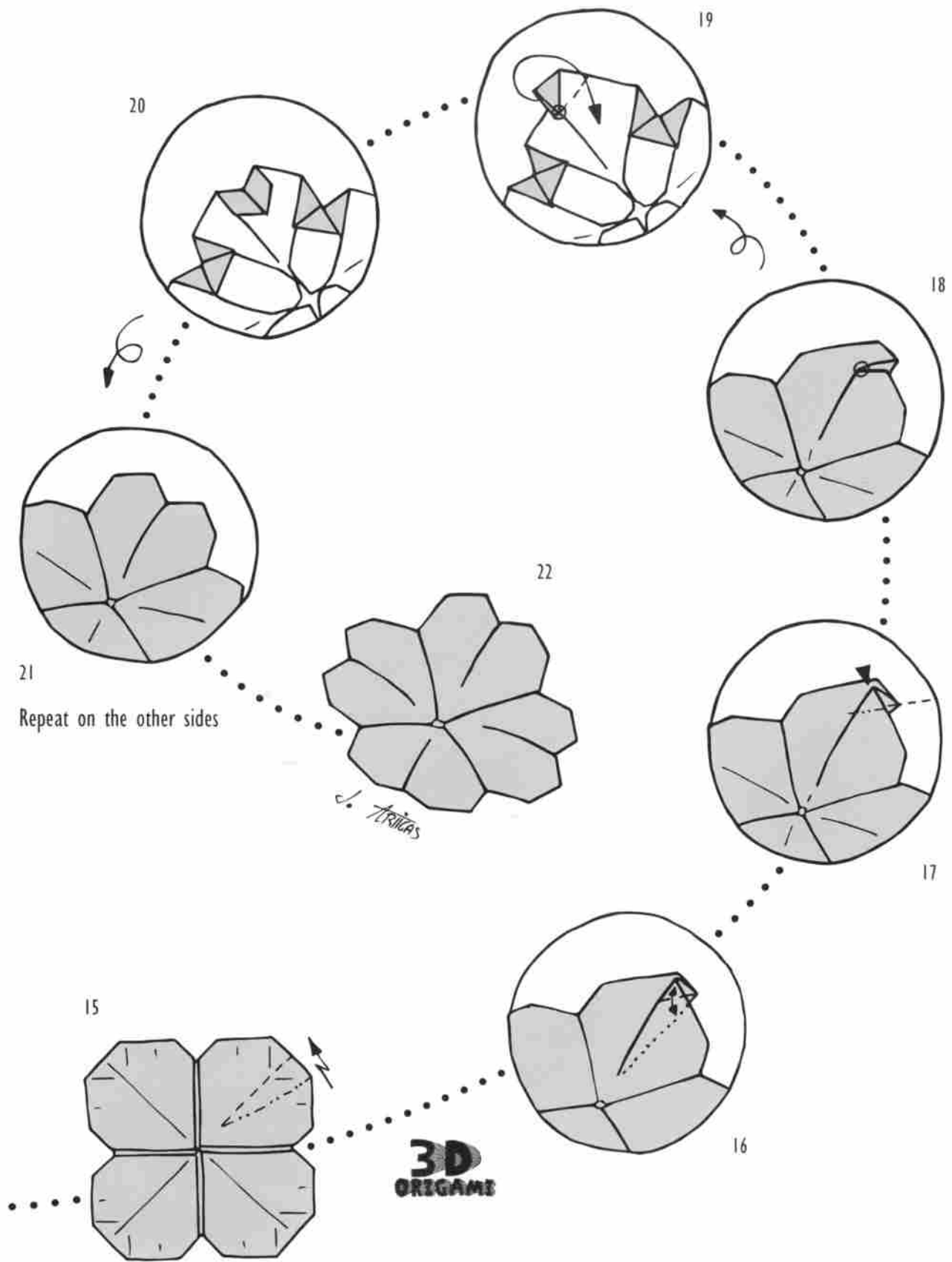

# 별(蘭) 유니트 1.2.3.4

## star(orchid) unit 1.2.3.4

by Son KyeSun : Korea

Diagram by Son KyeSun

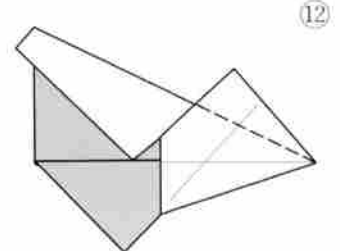
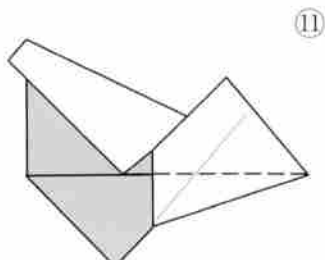
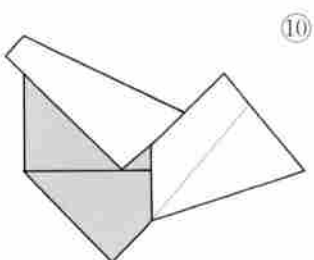
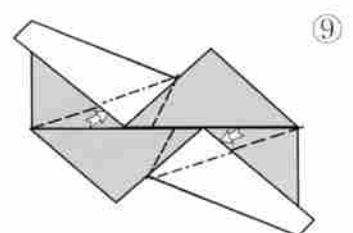
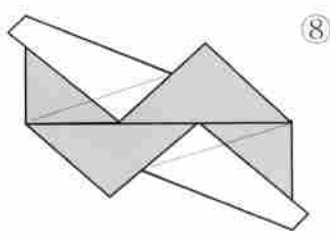
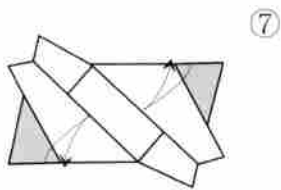
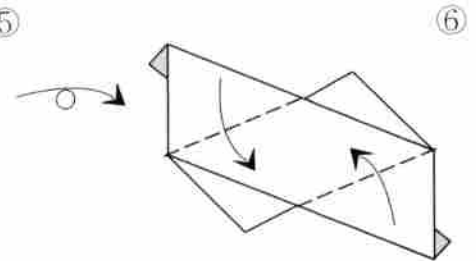
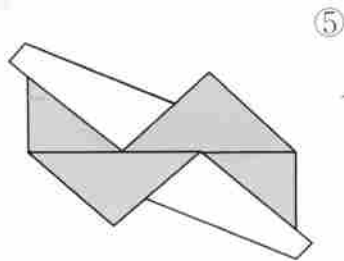
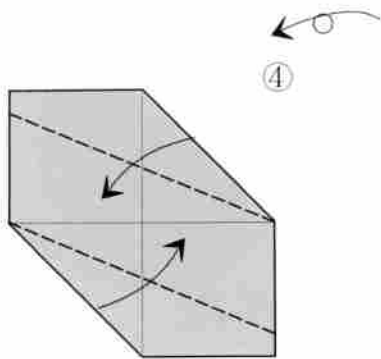
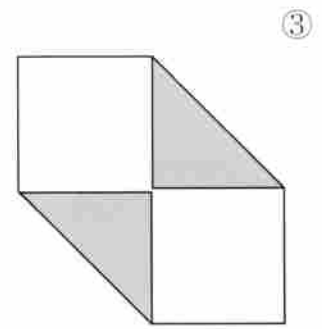
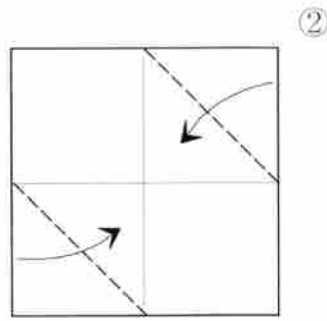
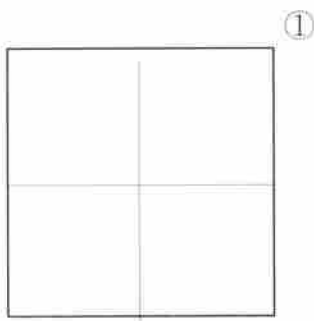
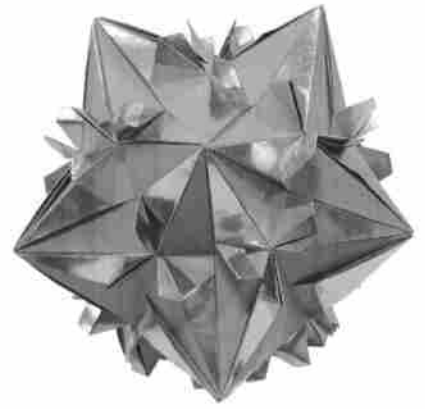

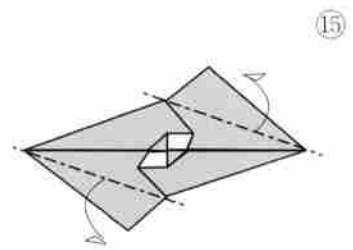
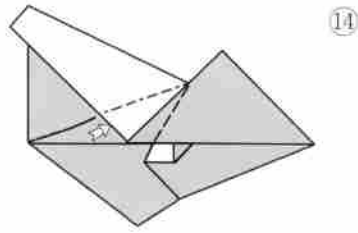
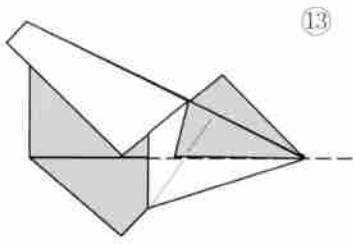

⑩~⑭까지 다른 쪽도  
같은 방법으로 접기

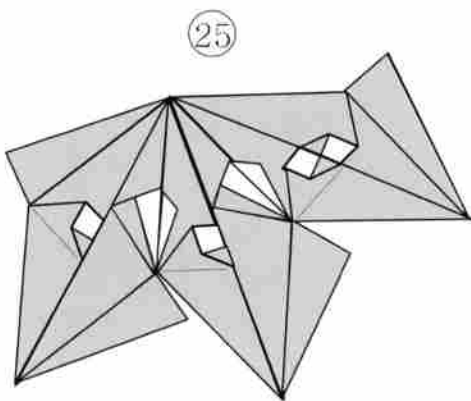
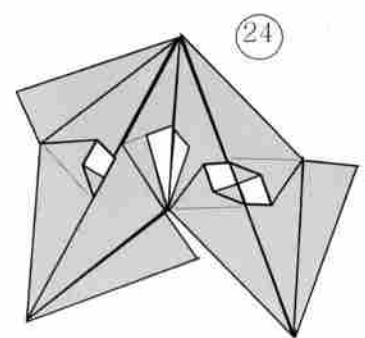
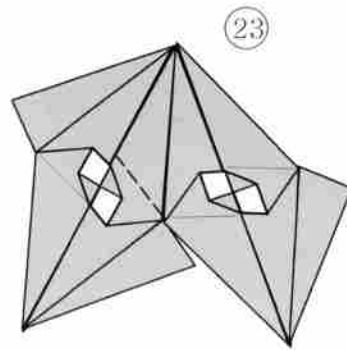
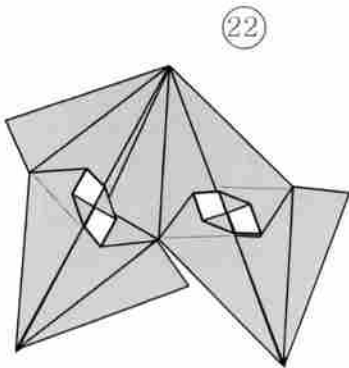
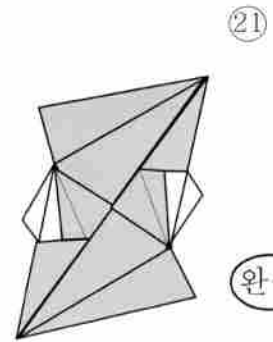
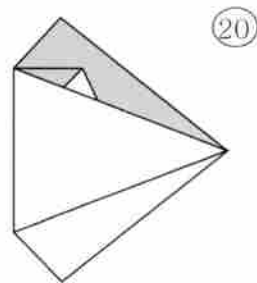
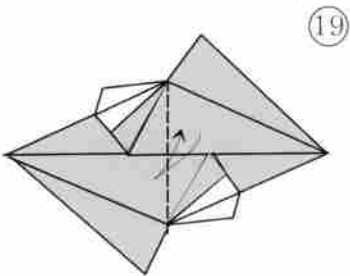
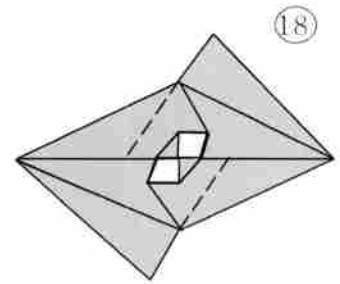
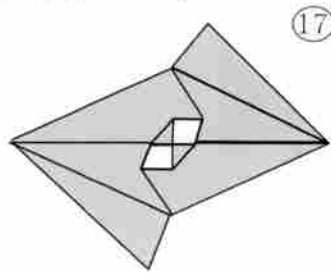
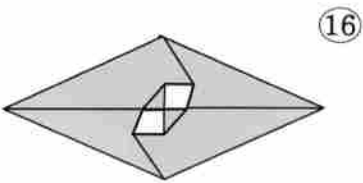

6매 조립



12매 조립

## 별(蘭) 유니트 3

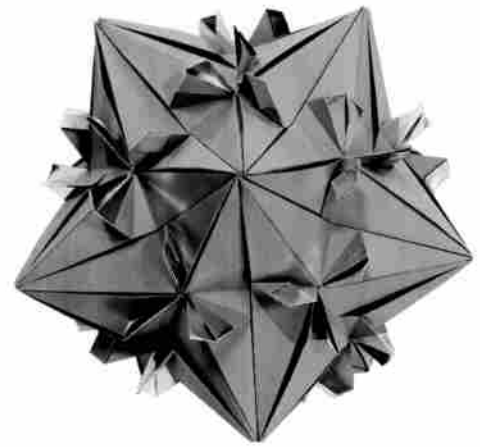
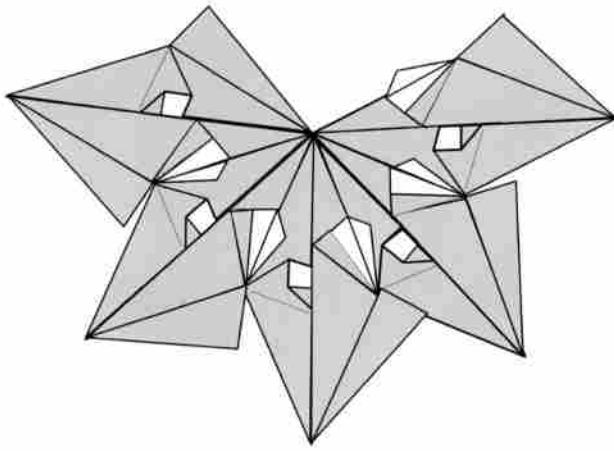

30매 조립

## 별(蘭) 유니트 4

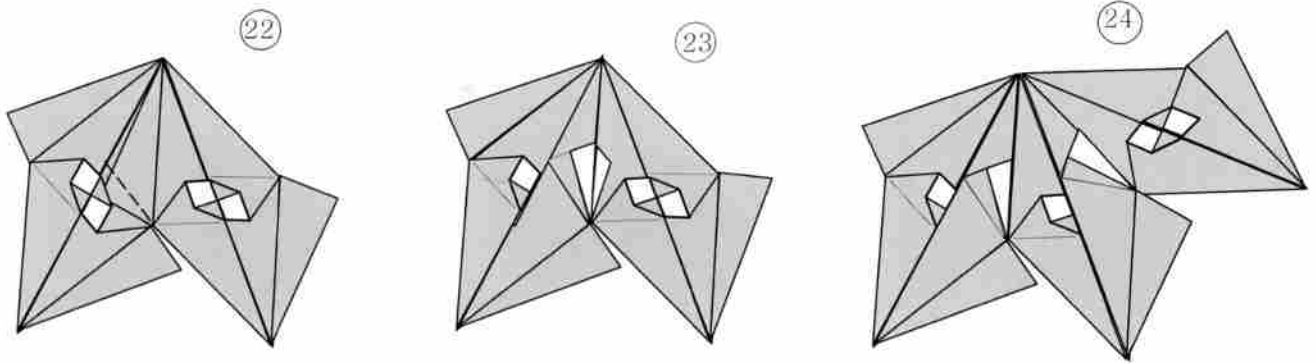

30매 조립

## 별(蘭) 유니트 변형5

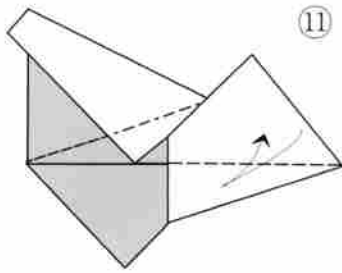

⑪

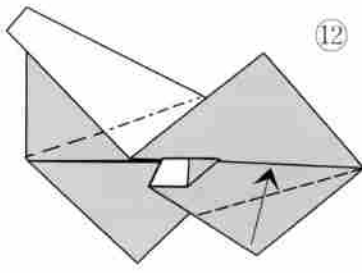

⑫

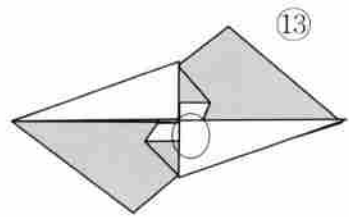

⑬

표시된 부분 끼우기

별 유니트 10번에서 시작하세요.

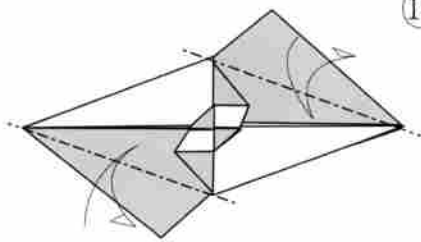

⑭

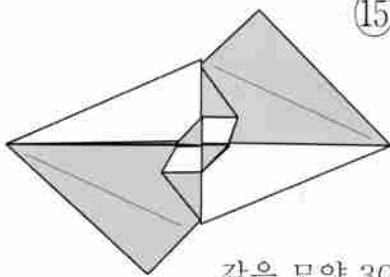

⑮

같은 모양 30매



같은모양 30매  
조립방법은 별(蘭) 유니트3 조립방법과 같습니다.

## 별(蘭) 유니트 변형6

같은모양 30매  
조립방법은 별(蘭) 유니트4 조립방법과 같습니다.

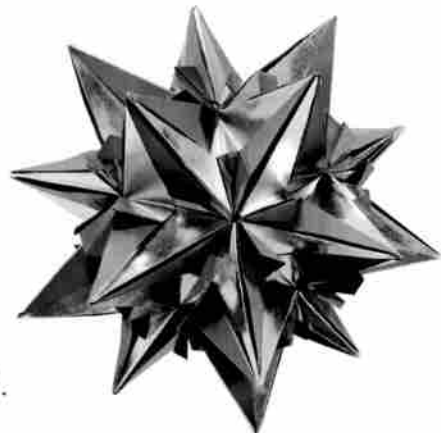

# Rotari Star

by Usman Rosyidhi : Indonesia

Diagram by Usman Rosyidhi

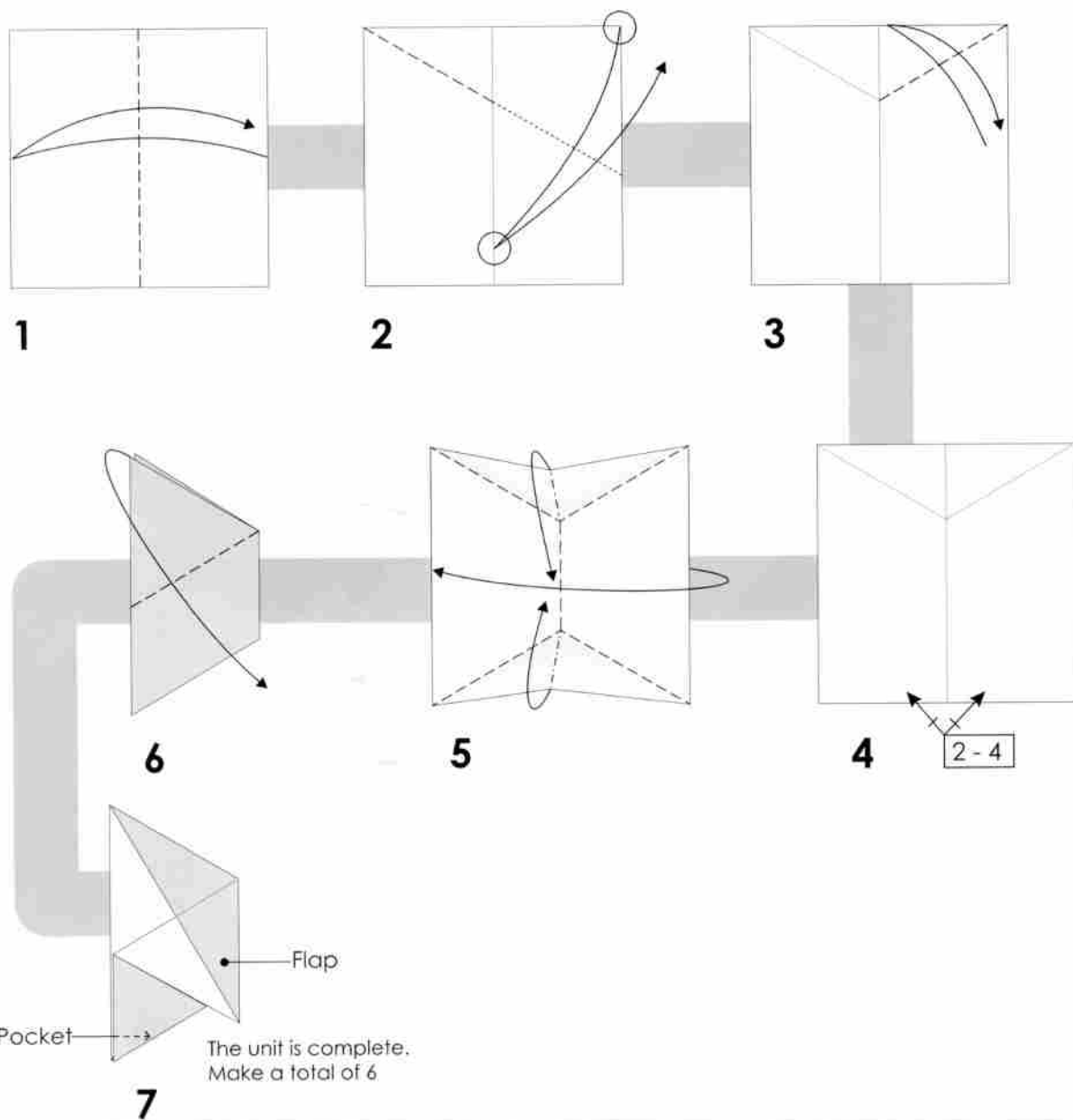

## Assembly

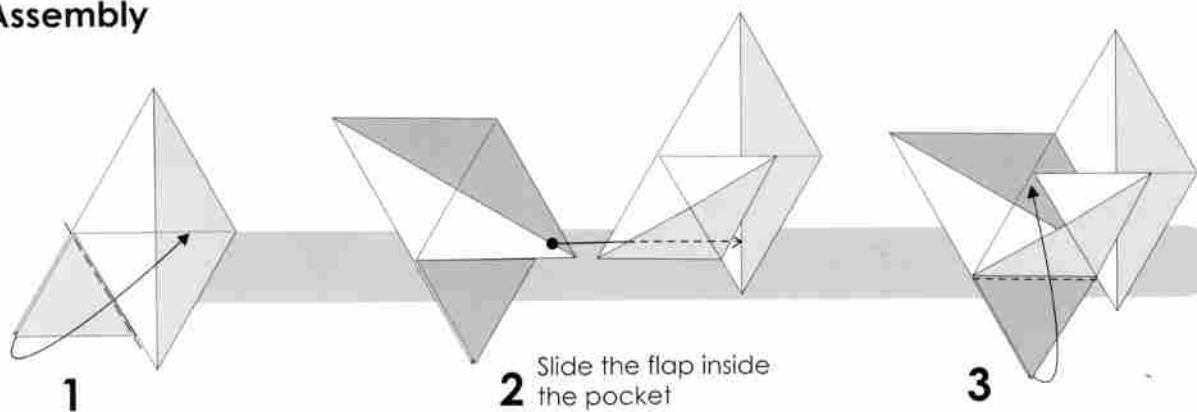



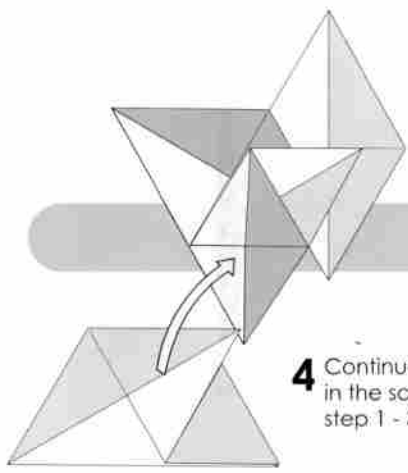

**4** Continue adding more units in the same way repeating step 1 - 3.

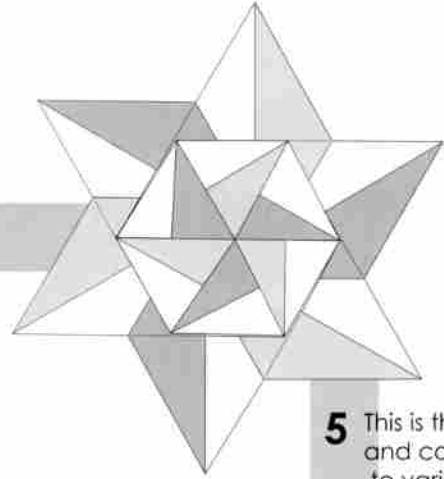

**5** This is the result and continue to variations ...

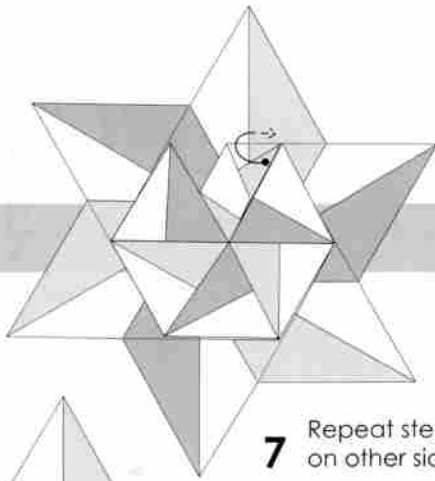

**7** Repeat step 6 - 7 on other sides

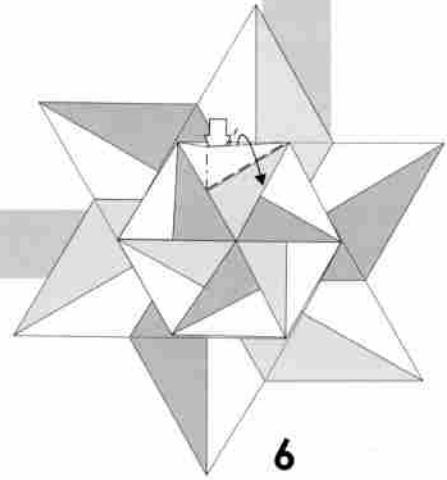

**6**  
variation A

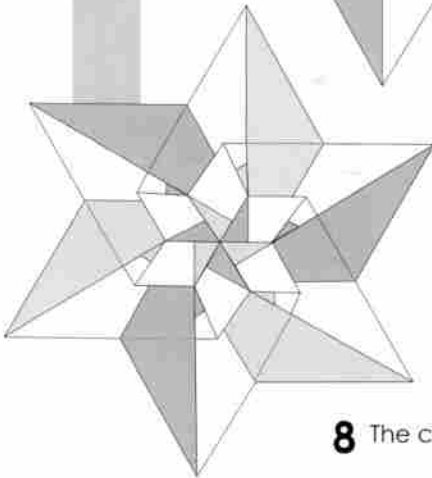

**8** The complete model

variation B

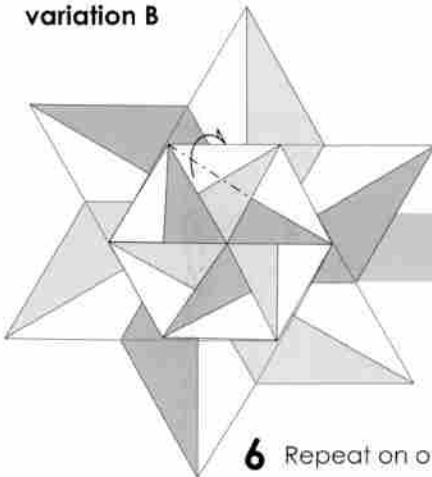

**6** Repeat on other sides

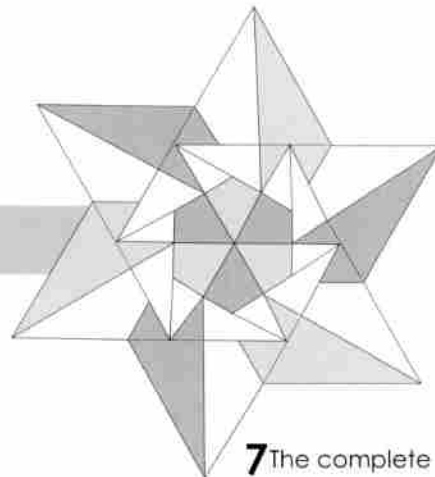

**7** The complete model

# 은하계 Galaxia

by Natalia Romanenko : Moldova

Diagram by Natalia Romanenko

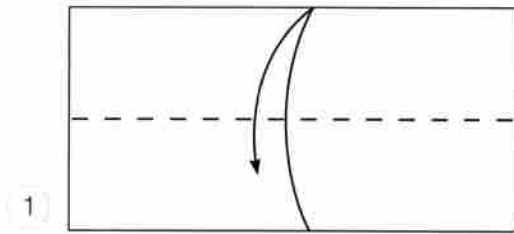
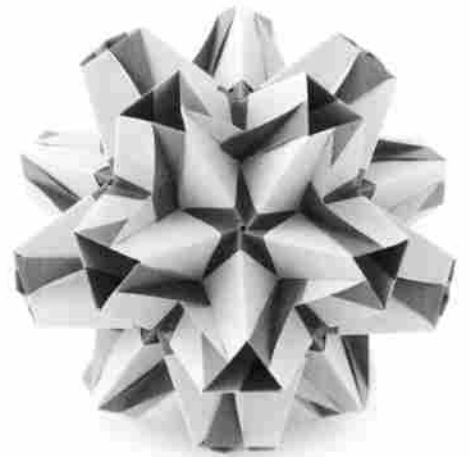

1

Rectangle of proportion 1 : 2

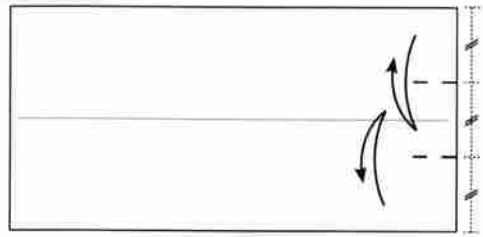

2

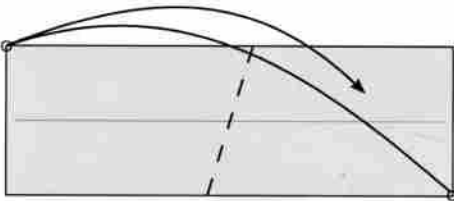

4

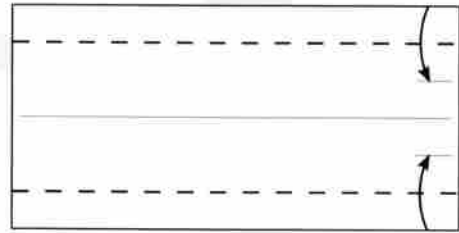

3

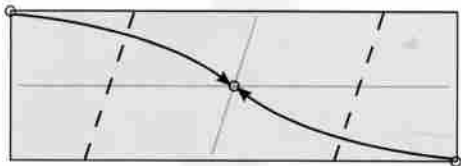

5

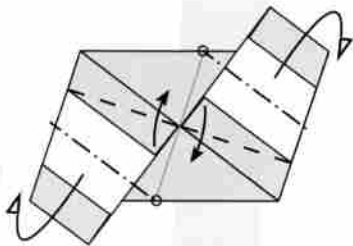

6

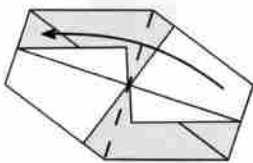

7

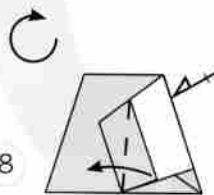

8

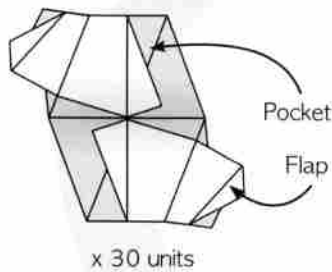

x 30 units

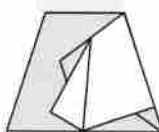

9

Finished unit

# Umbrella Ball

by Le Danh : Vietnam

Diagram by Le Danh

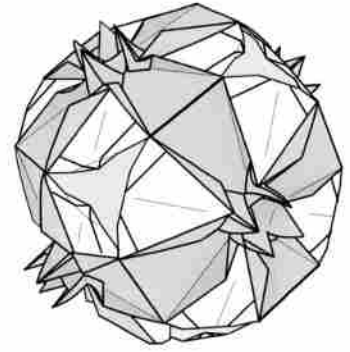

Inspired from the time I was into the game. This design was stylized type based on the umbrella corporation's logo in the Evil Resident game and movie.

- 1**

Fold and unfold.
- 2**

Fold and unfold.
- 3**

Fold and unfold.
- 4**

Fold and unfold, notice the circled point.
- 5**

Fold and unfold, notice the circled point.
- 6**

Fold and unfold. Turn over.
- 7**

Collapse, using the creased lines.
- 8**

Model will not be flat.
- 9**
- 10**

Magnify.
- 11**

Bird-base fold.
- 12**

Fold back, zoom out.

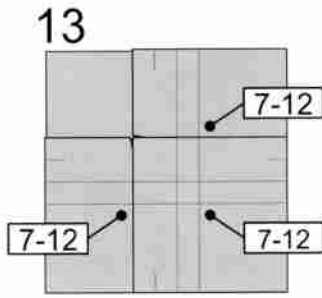

Repeat step 7-12 on the rest corners.

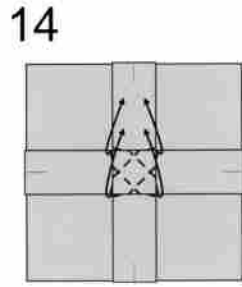

Fold up the small flaps. Model will not be flat.

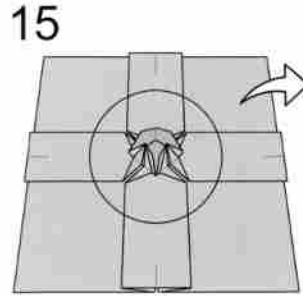

Magnify.

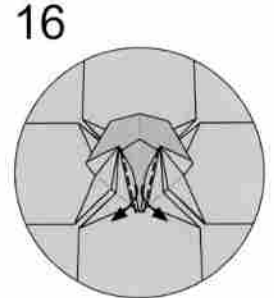

Squash fold two sides.

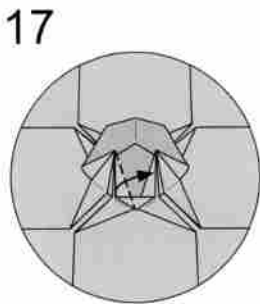

Valley fold.

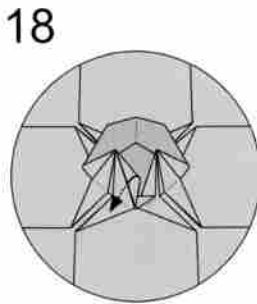

Fold the flap into the pocket and repeat on the rest flap.

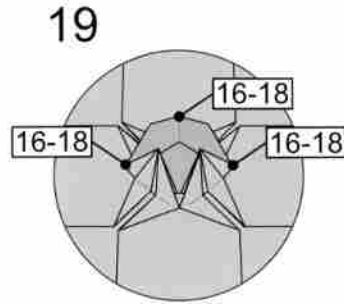

Repeat step 16-19 on the 3 flaps.

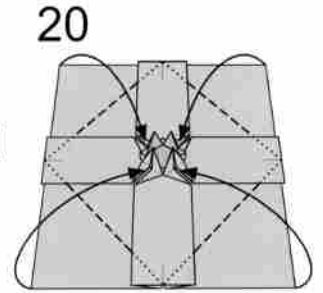

Valley fold the layers into the pockets.

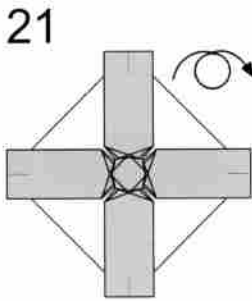

Perpendicular view and turn over.

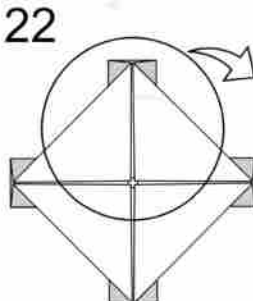

Magnify.

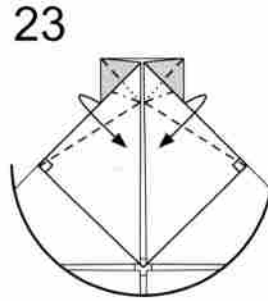

Fold the corner.

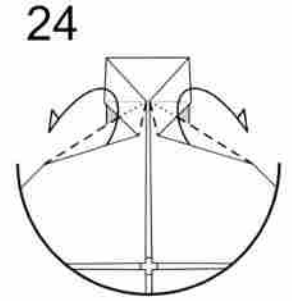

Reverse the flap to behind.

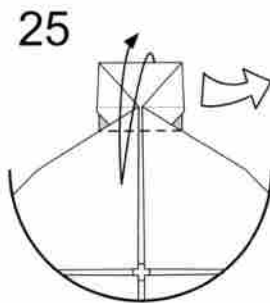

Fold and unfold, Zoom out.

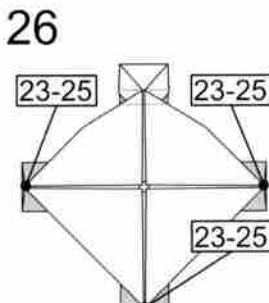

Repeat on the rest corners.

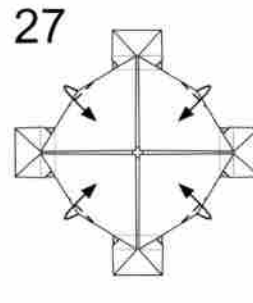

Valley fold.

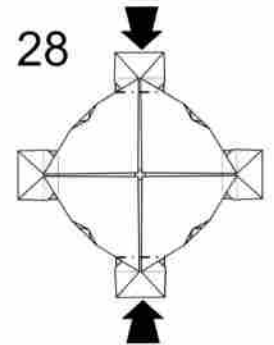

Open sink.

29

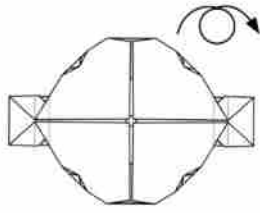

Turn over.

30

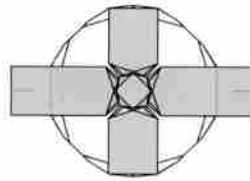

Finish a module.

31

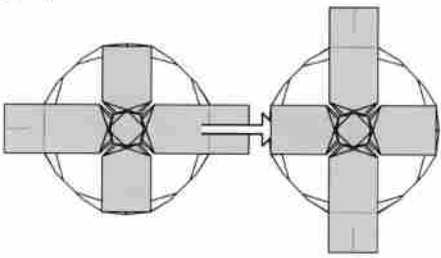

Connect 2 modules by inserting the flap into the pocket.

32

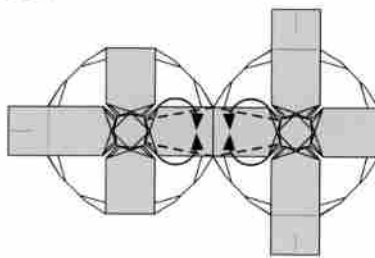

Lock the combination by making the valley fold.

33

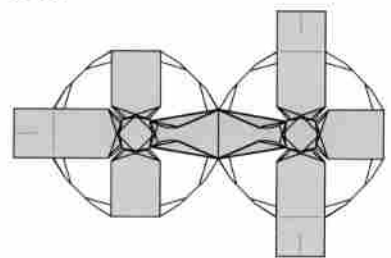

Finish connecting.

34

Combine 6 modules following to the diagram:

- A-A'
- B-B
- C-C'
- D-D'
- E-E'
- F-F'
- G-G'

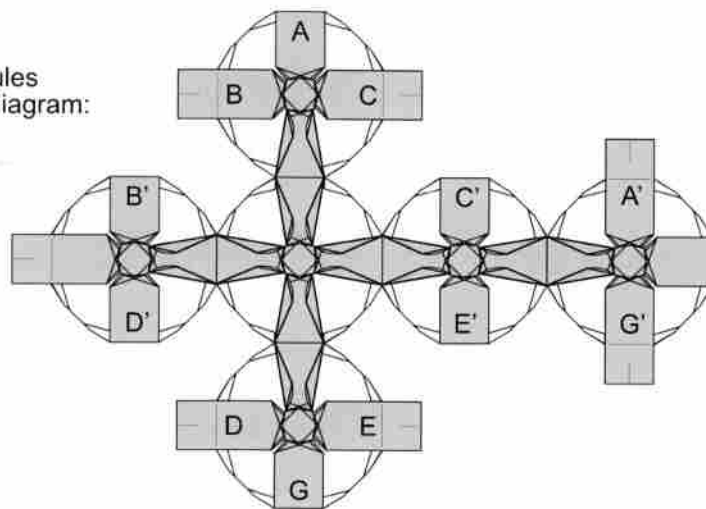

35

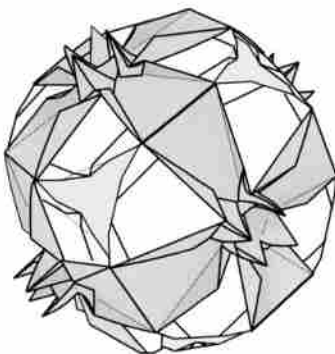







Umbrella Ball Completed.

# Ball pop up card

by Leonardo Pulido Martinez : Colombia

Diagram by Leonardo Pulido Martinez

Paper:	Type:	Square 
	Size:	20 cm Recommended
	Color:	Bicolor 
Type:	Origami Action 	
Time:	60 minutes 	
Level:	Intermediate 	
Date:	April 2019 	

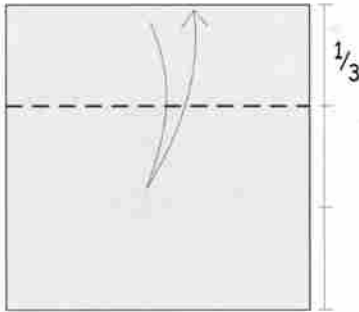
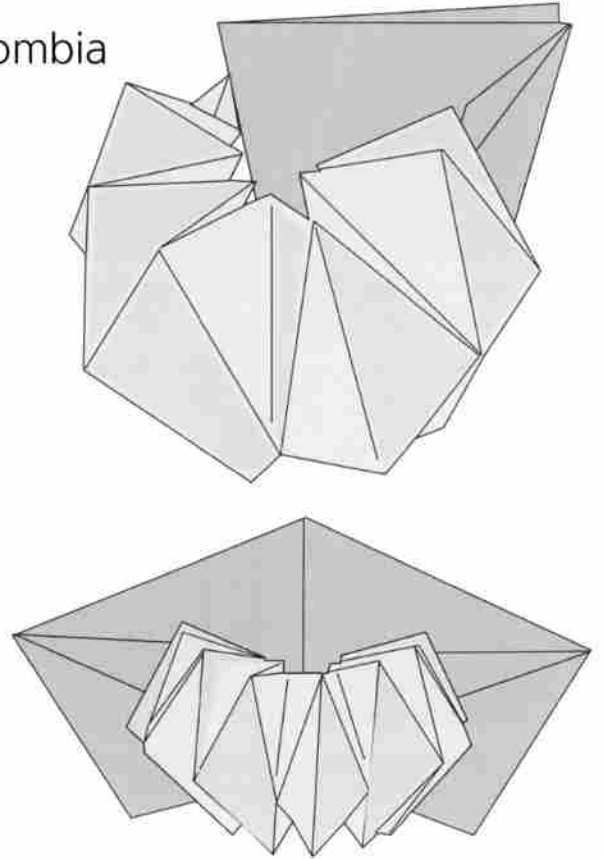

① Precrease

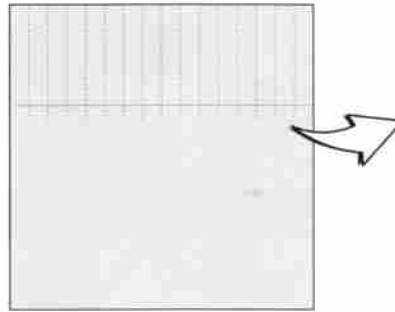

② Precrease (valley)  
16 parts

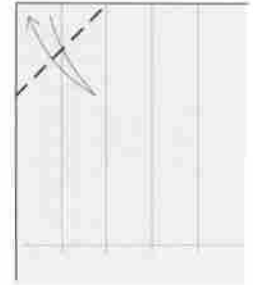

③ Precrease  
(45°)

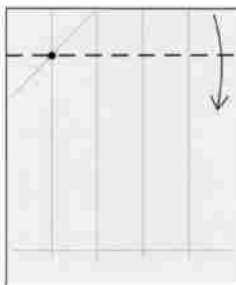

④ Valley Fold

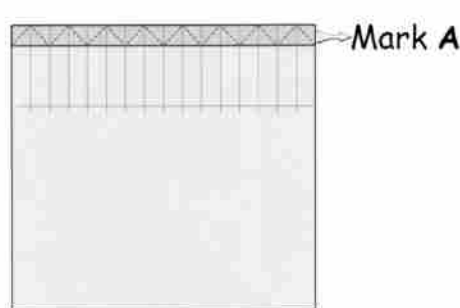

⑤  
Valley Fold on two layers

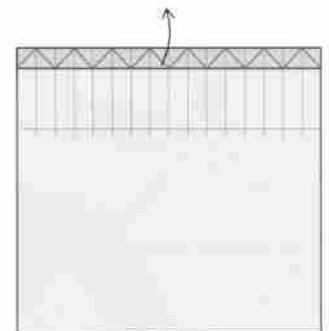

⑥ Unfold

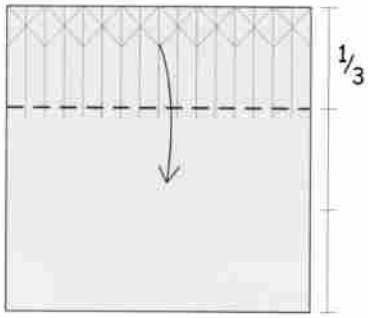

7 Valley fold

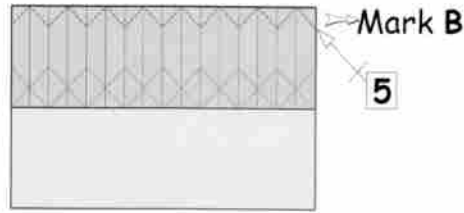

8 Valley Fold on two layers

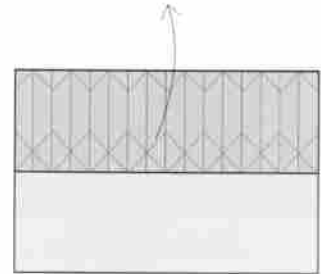

9 Unfold

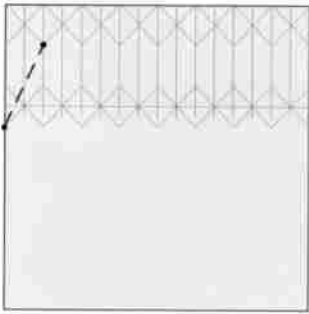

10 Precrease

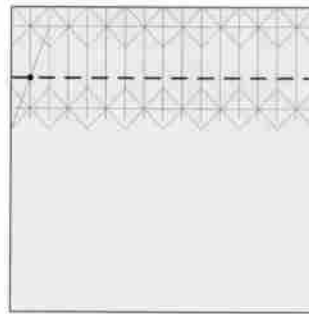

11 Precrease

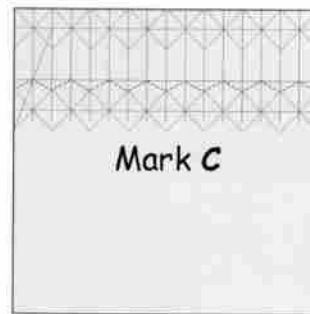

12 Precrease

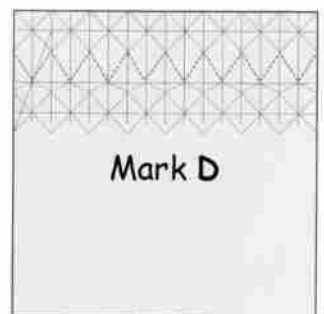

13 Precrease

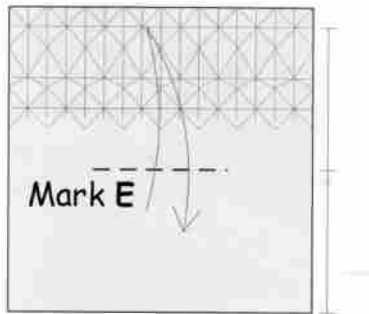

14 Precrease

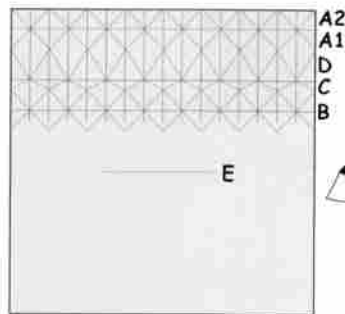

15 Marks

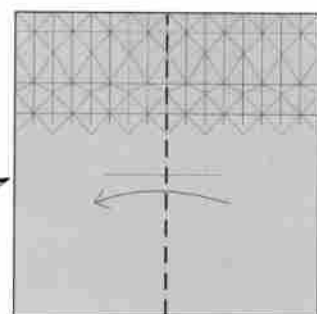

16 Valley Fold  $\frac{1}{2}$

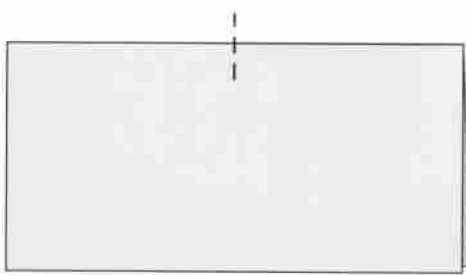

17 Precrease  $\frac{1}{2}$

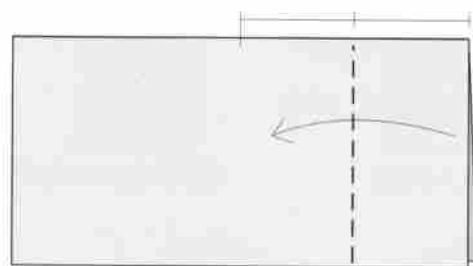

18 Valley Fold ( $\frac{1}{4}$ )

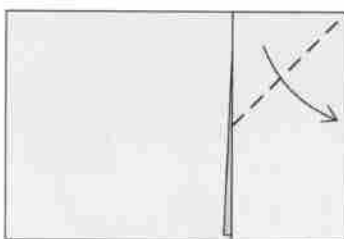

19 Fold  $45^\circ$

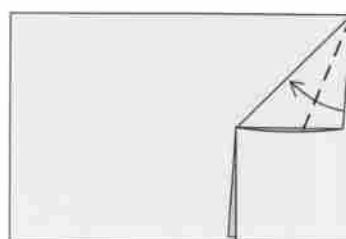

20 Valley fold

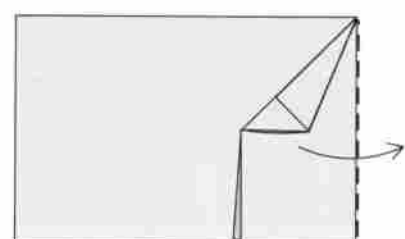

21 Unfold

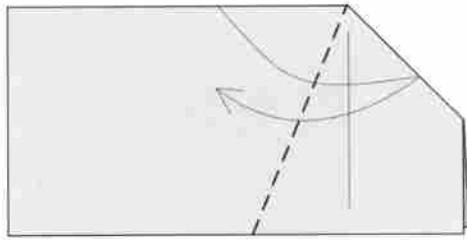

**22** Precrease  
Fold and unfold

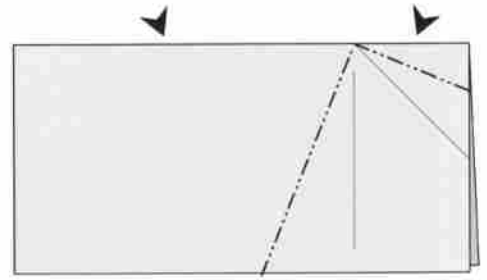

**24** Sink 45°

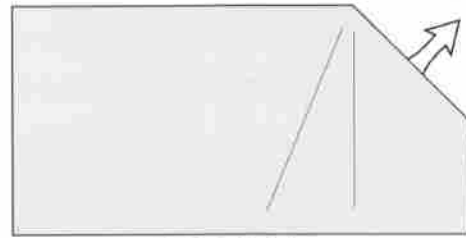

**23** Unfold

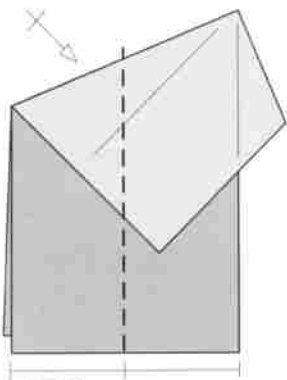

**25** Precrease

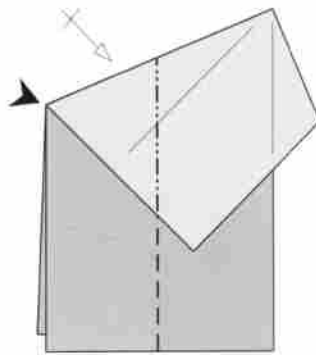

**26** Sink

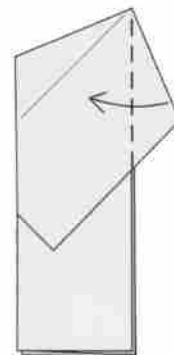

**27** Valley fold

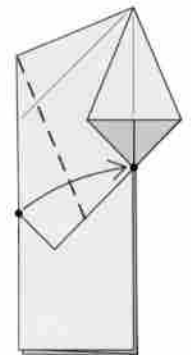

**28** Valley fold

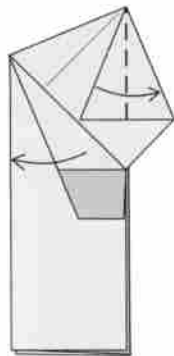

**29** Unfold

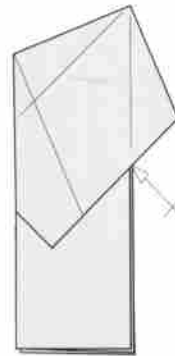

**30** Repeat behind

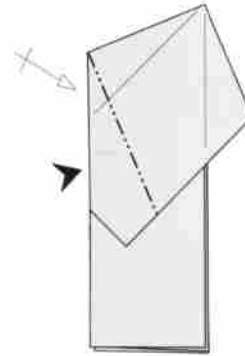

**31** Sink

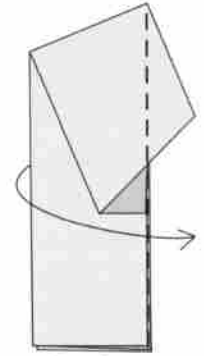

**32** Open

27-29

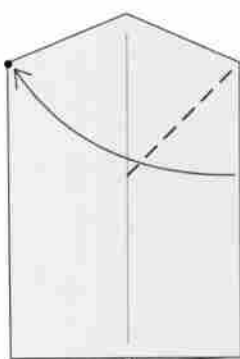

**33** Precrease

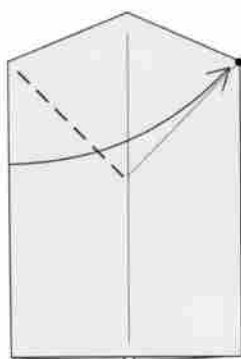

**34** Precrease

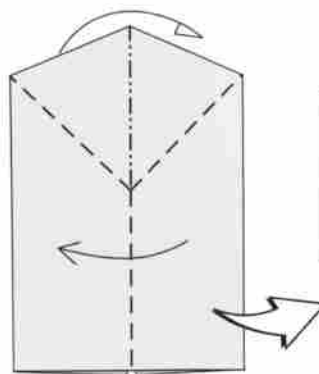

**35** Fold by  
the marks

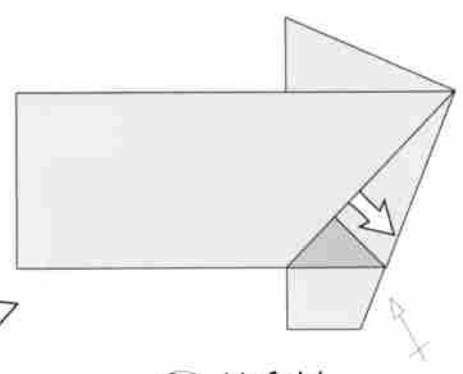

**36** Unfold



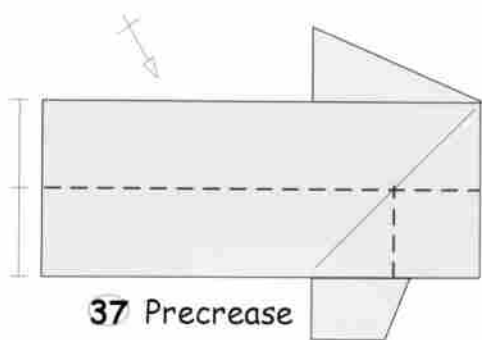

37 Precrease

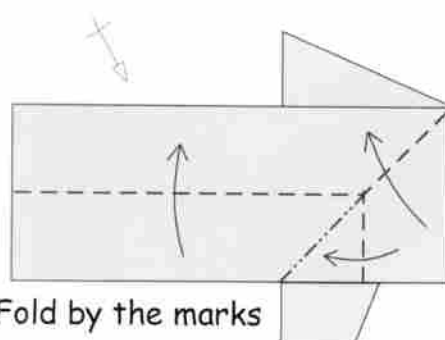

38 Fold by the marks

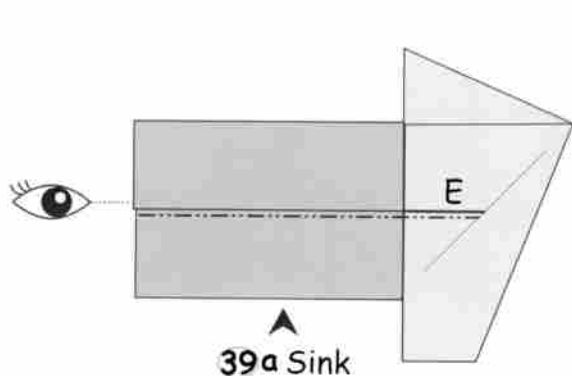

39a Sink

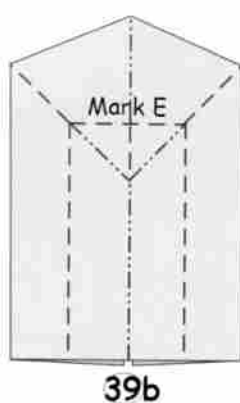

39b

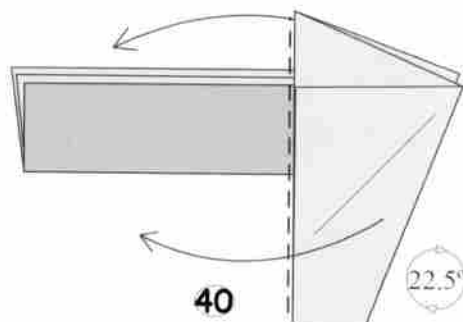

40

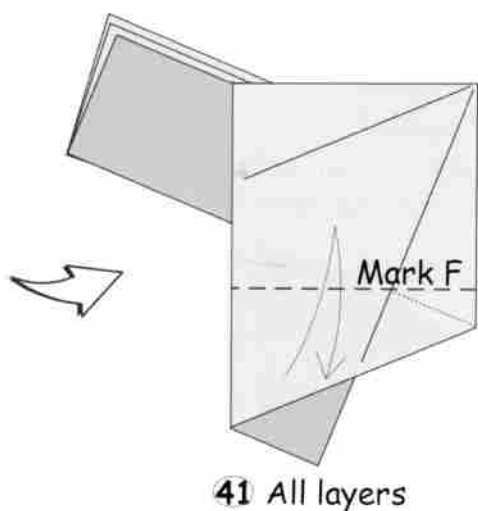

41 All layers

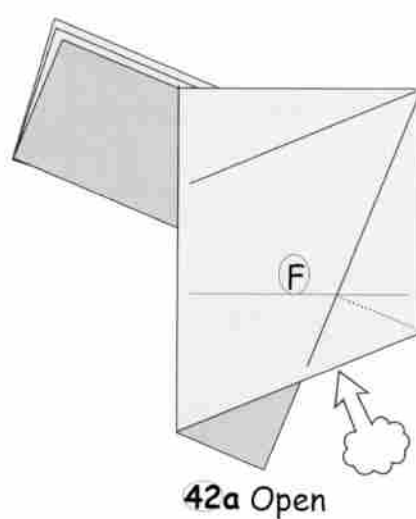

42a Open

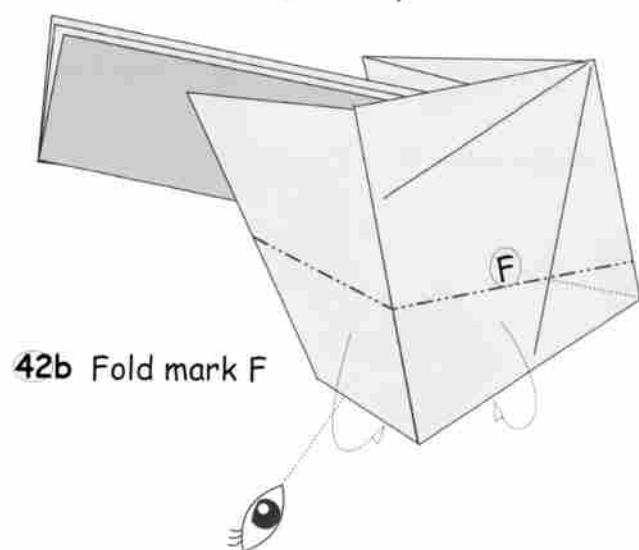

42b Fold mark F

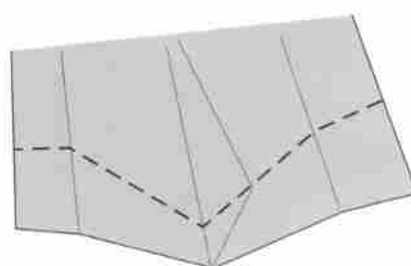

42c Catch this layer

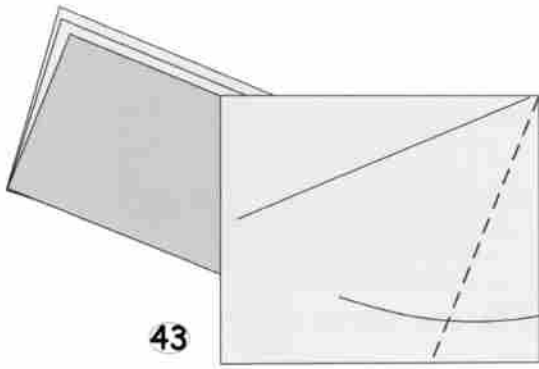

43

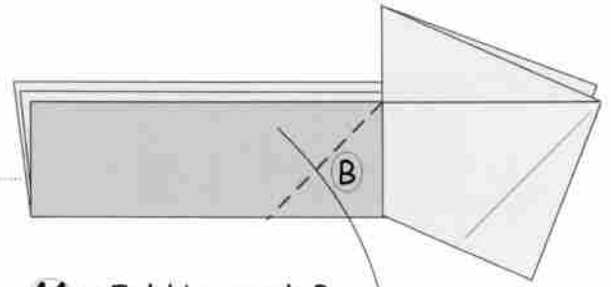

44 a Fold by mark B  
(open the model)

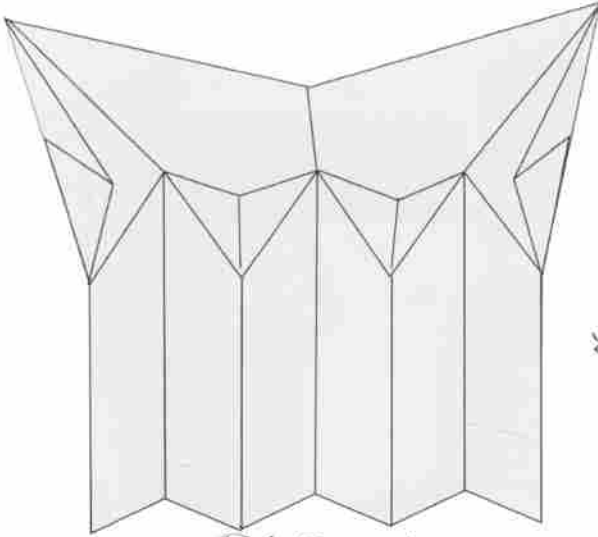

44 b Front view

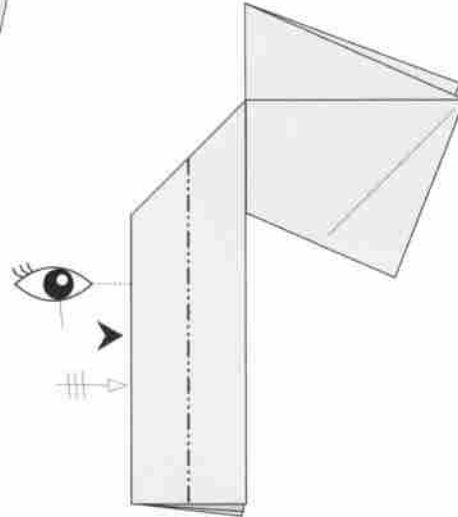

45 a Open sink  
(open the model)

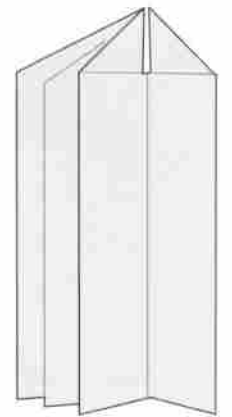

45 b Front view

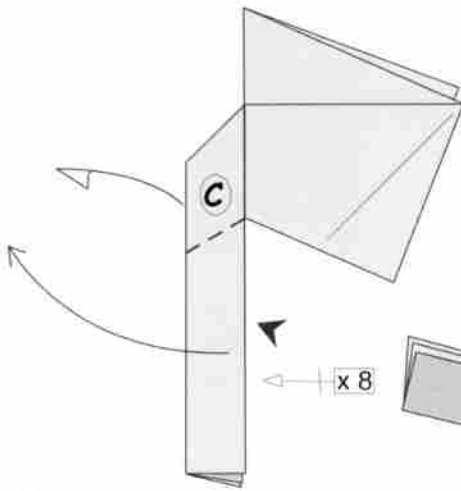

46 Fold by mark C  
(open the model)

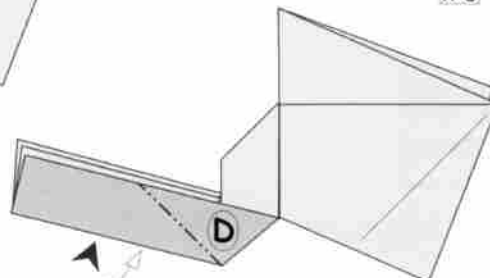

47 Sink on mark D

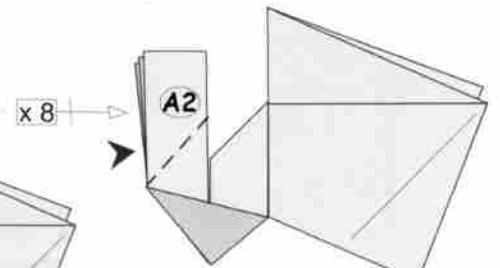

48 Fold by mark A2  
(open the model)

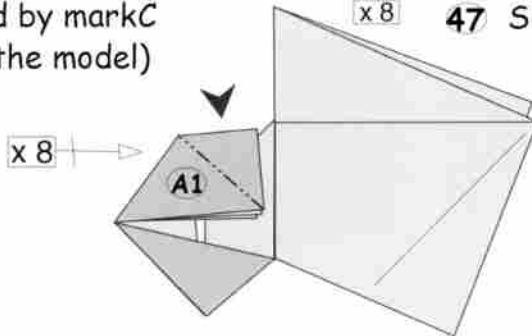

49 Sink on mark A1  
(open the model)

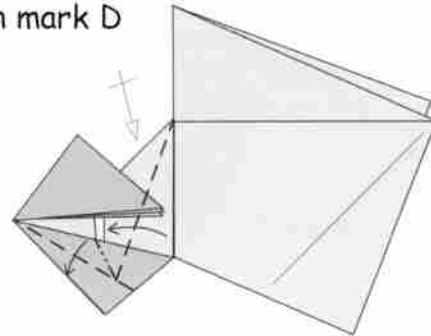

50 a Repeat behind

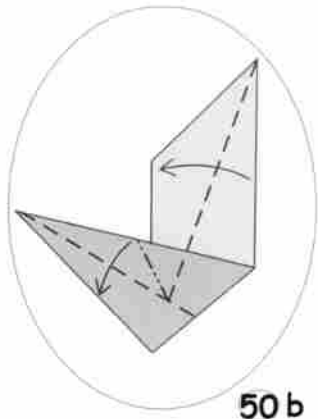

50 b

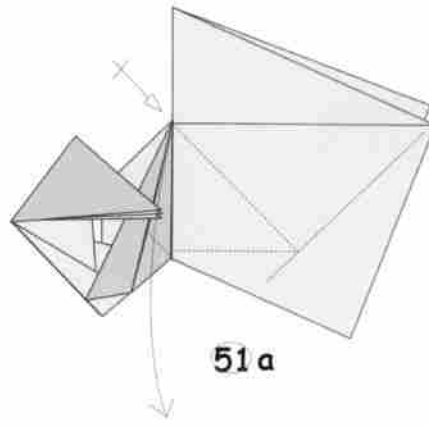

51 a

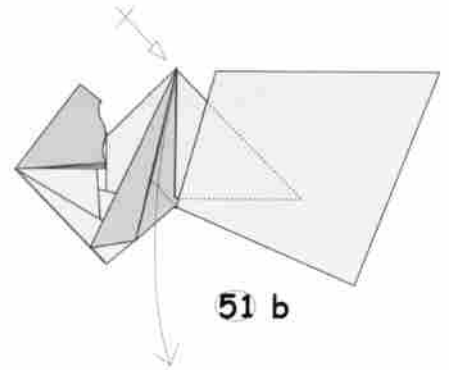

51 b

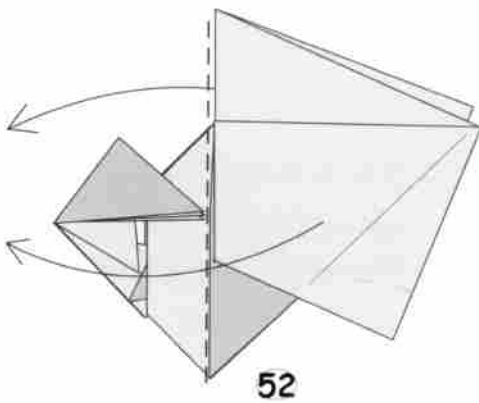

52

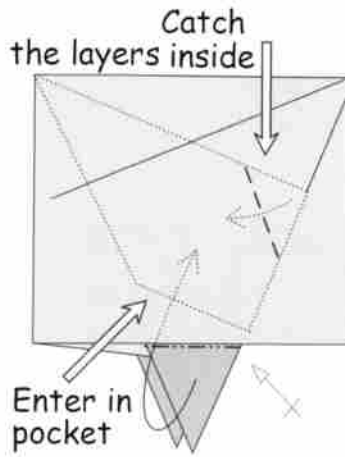

53 X ray view

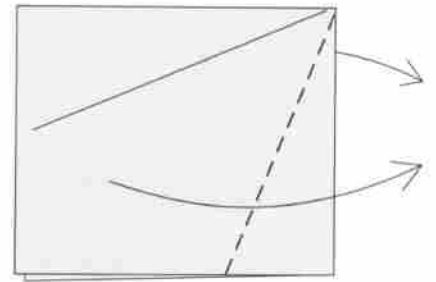

54 Card finished (open)

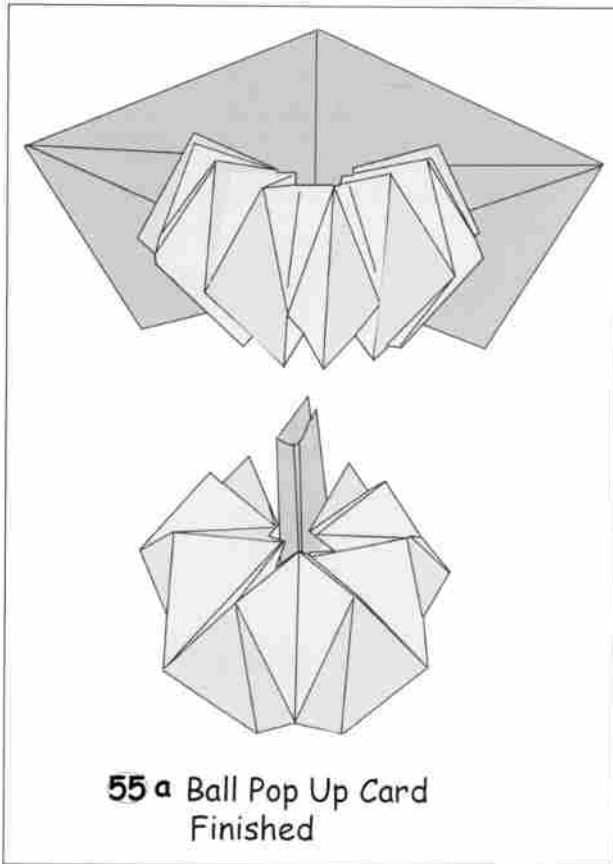

55 a Ball Pop Up Card Finished

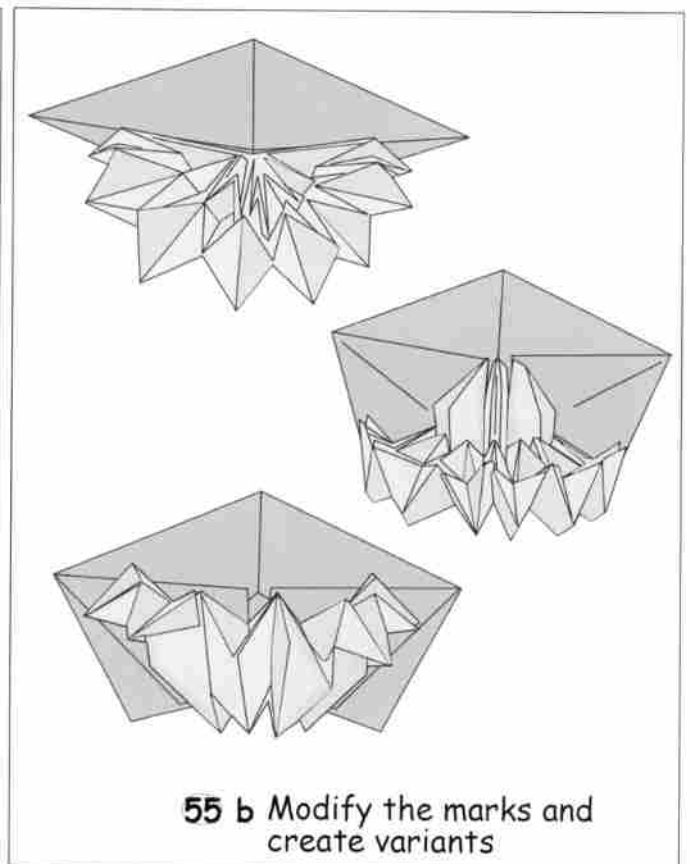

55 b Modify the marks and create variants

# 꽃병 Vase

by Oh KyungRan : Korea  
Diagram by Oh KyungRan

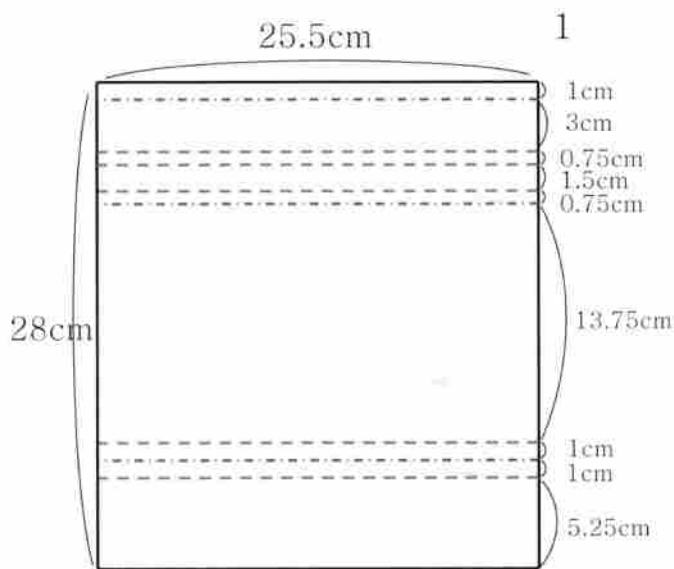

표시선처럼 접었다 펴세요.  
Fold and unfold as shown.

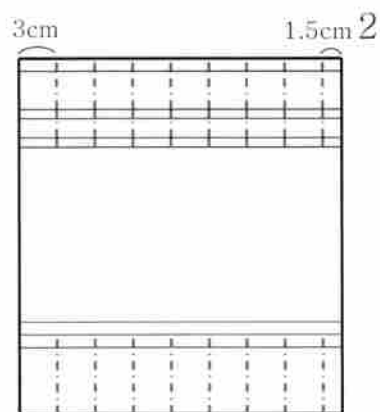

산접기 (Mountain fold)

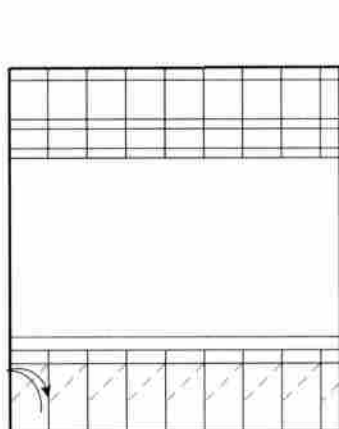

골짜기접기 하세요 ( $45^\circ$ )  
Valley fold ( $45^\circ$ )

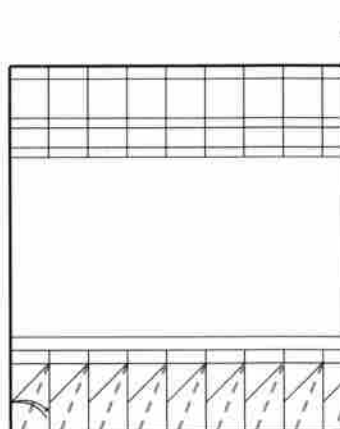

골짜기접기 하세요 ( $22.5^\circ$ )  
Valley fold ( $22.5^\circ$ )

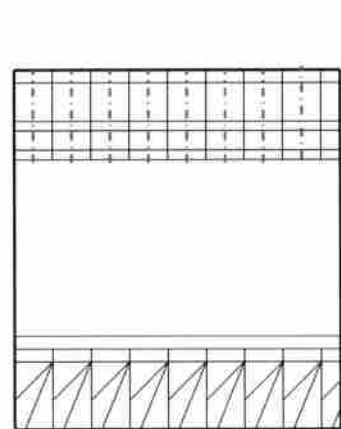

산접기 (Mountain fold)



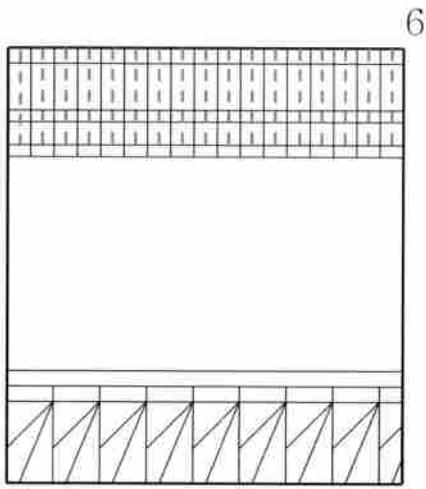

6  
골짜기접기 (Valley fold)

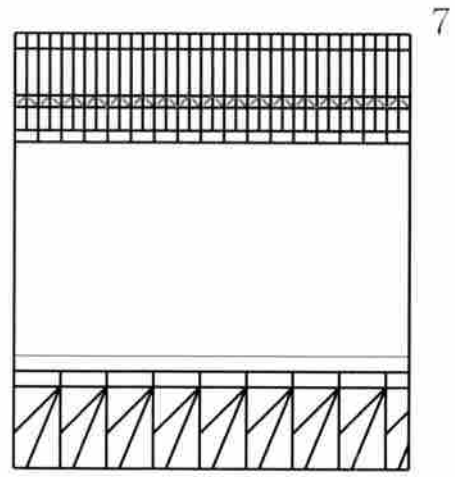

7  
표시선처럼 접었다 펴세요.  
Fold and unfold as shown.

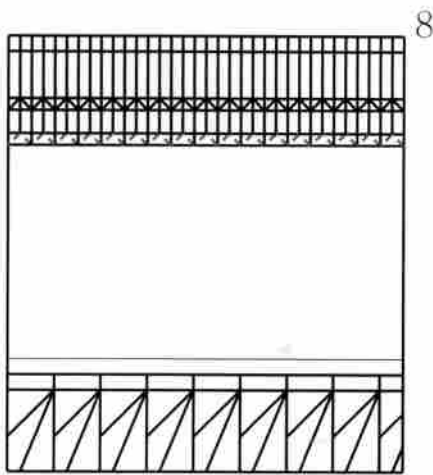

8  
표시선처럼 접었다 펴세요.  
Fold and unfold as shown.

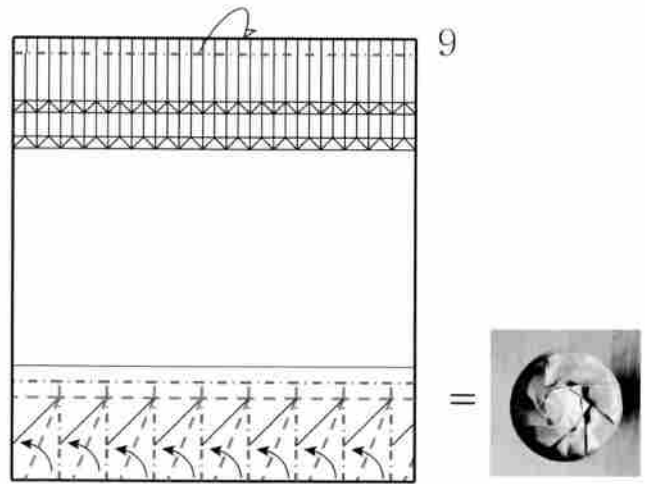

9  
위 (upper part): 산접기 (Mountain fold).  
아래: 표시선처럼 접어 밑면을 만드세요.  
Lower part: Fold as shown to make  
the bottom of a vase.

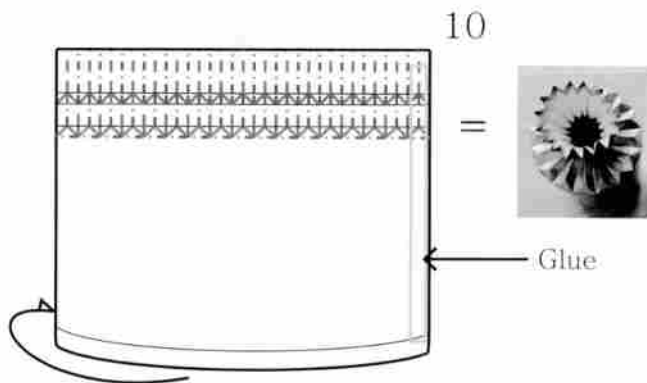

10  
표시선처럼 접어 화병의 입구(주둥이)를  
만드세요.  
Fold as shown to make the opening  
of a vase.



완성 (Completed)

# 전등갓 Lampshade

by Kaito Nagayama : Japan

Diagram by Kaito Nagayama

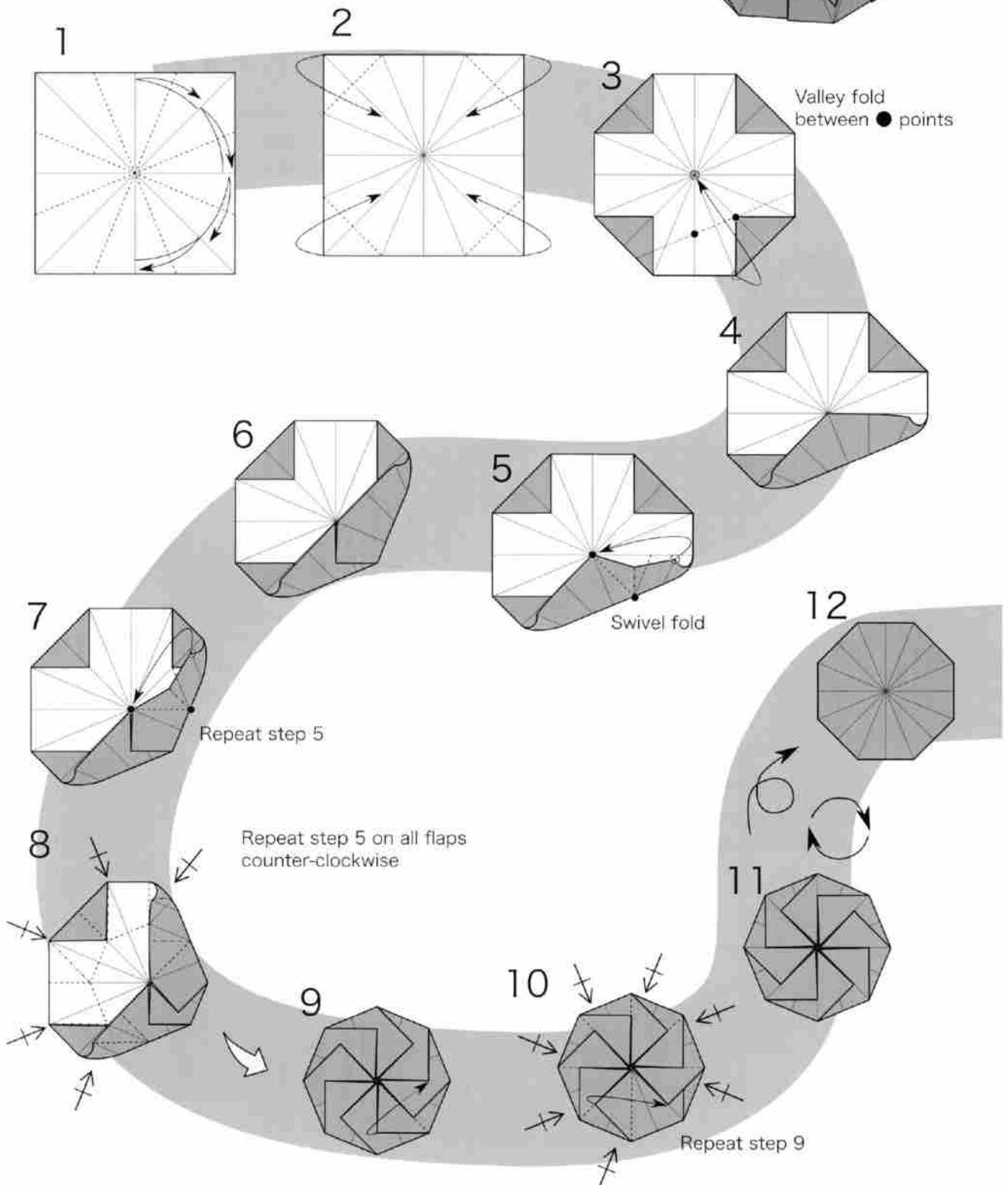
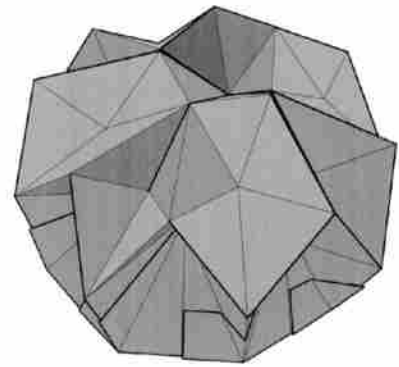

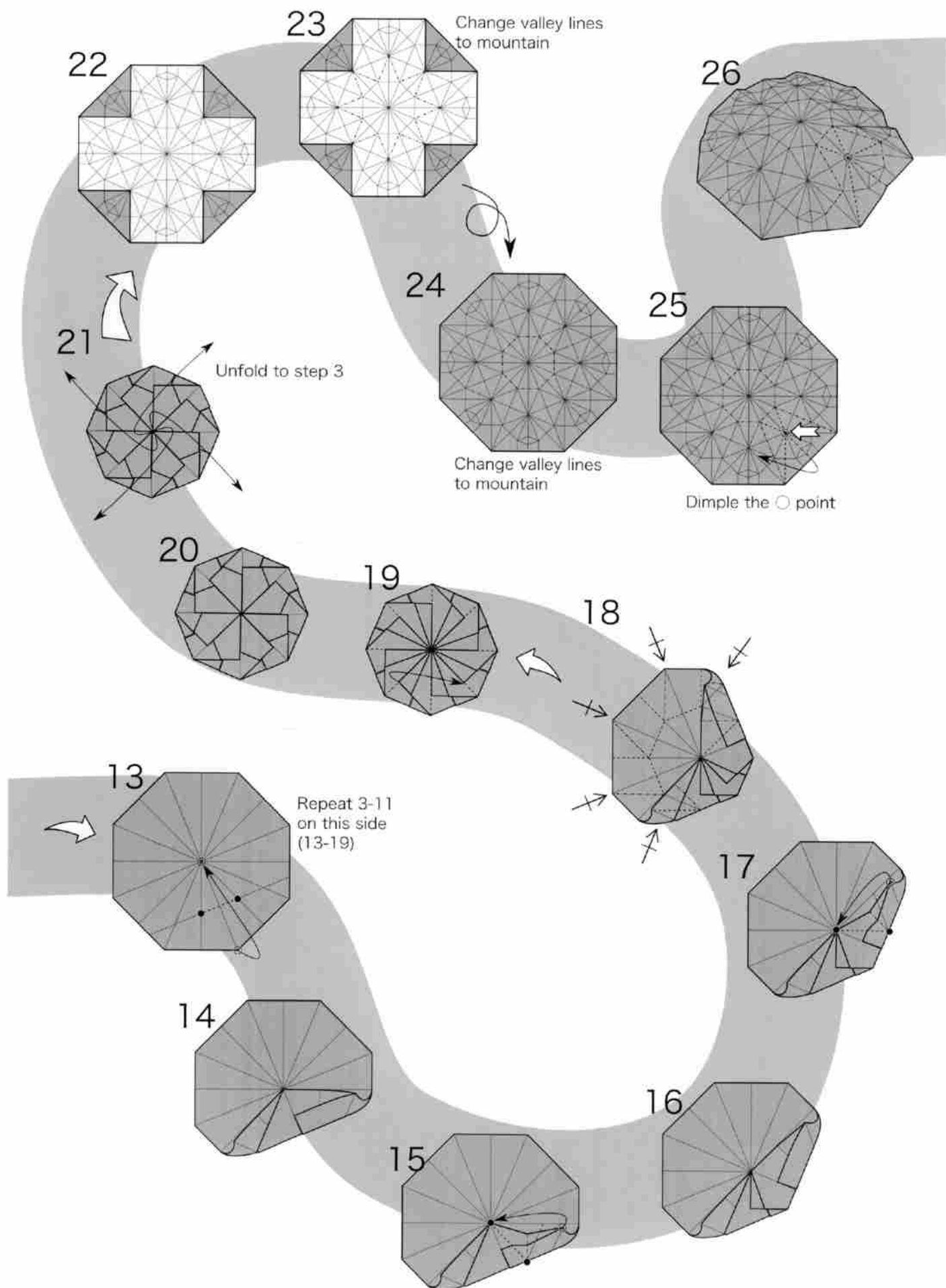

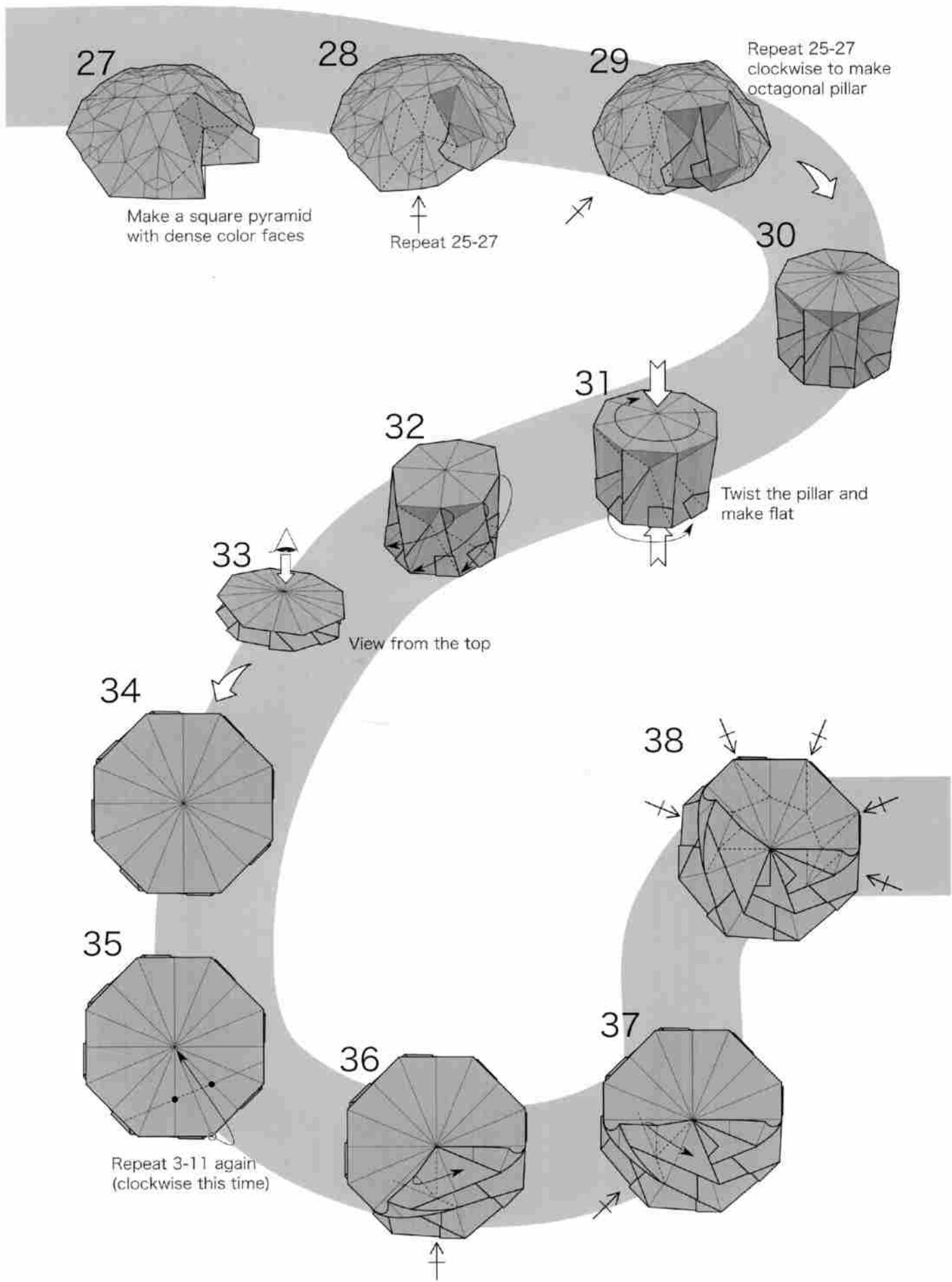



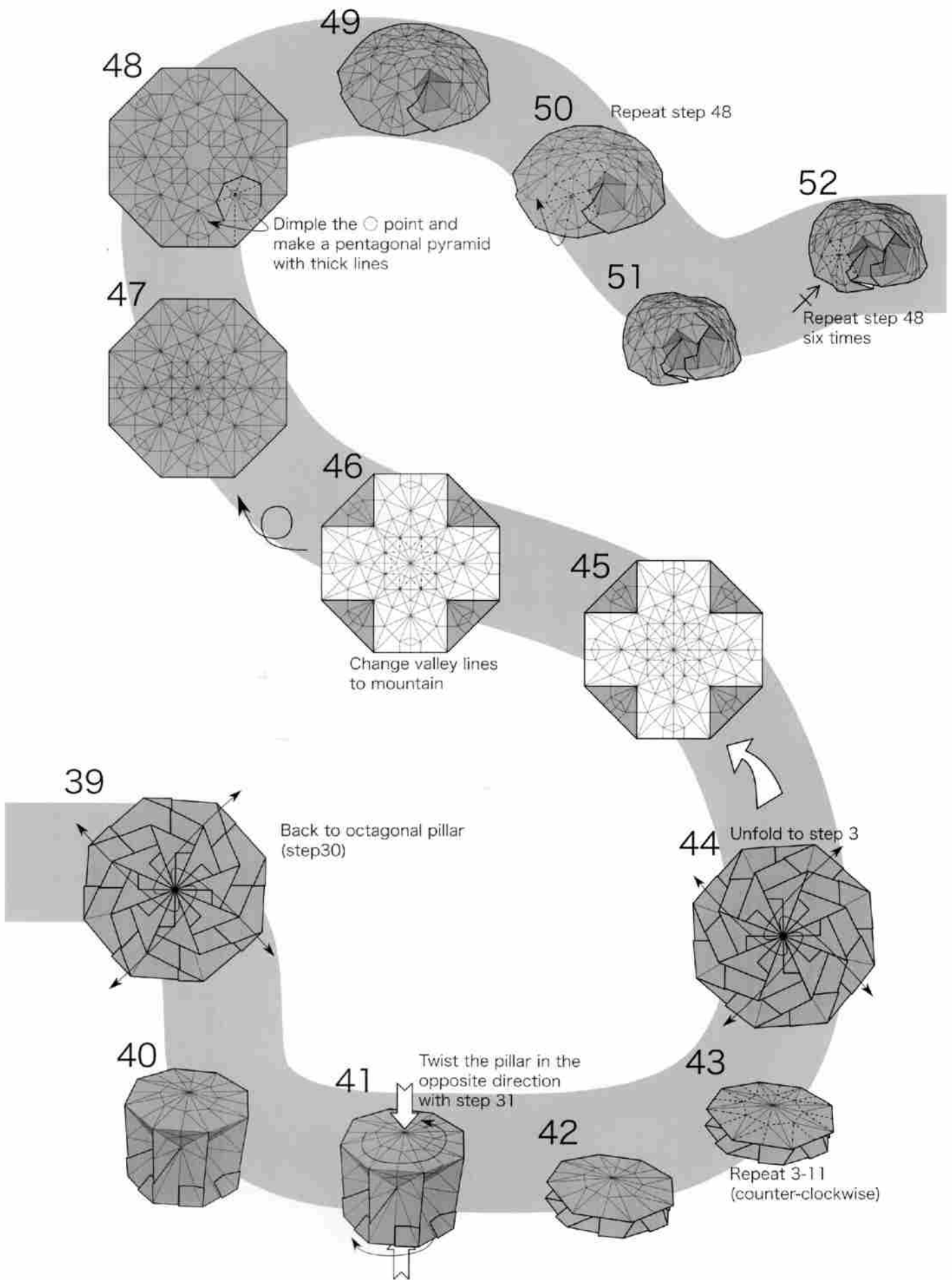

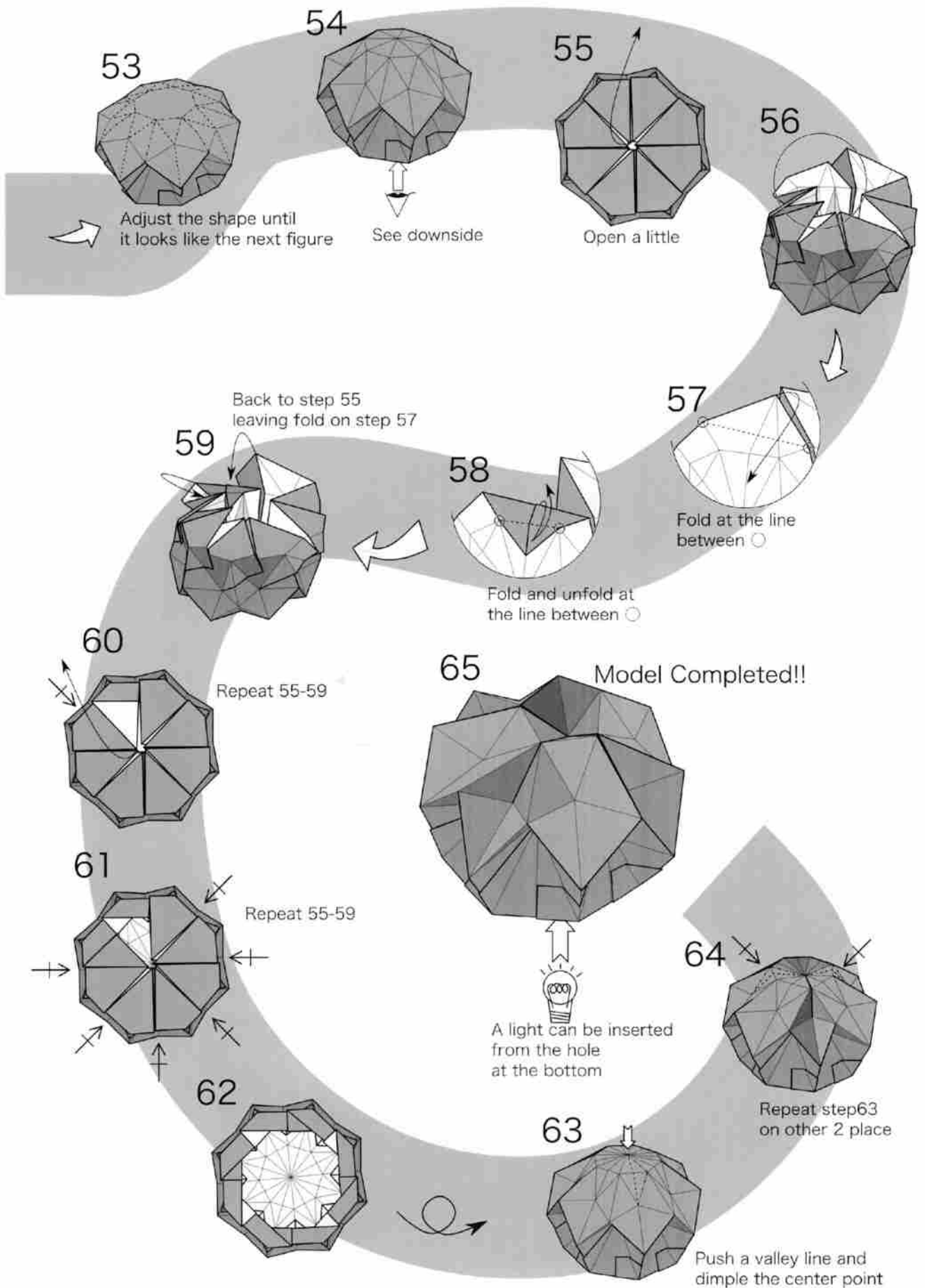

# (사)한국종이접기협회 회원등록 안내

## <협회사업 및 활동>

### ■ 협회보 「종이문화」 발행

각 교육기관, 사회단체에서 지도 및 작품 활동할 수 있도록 종이접기를 중심으로 한 종이조형예술 작품을 해설한 전문지로 연 4회 종이문화에 대한 최신 정보를 게재

### ■ 부설 종이문화원 (종이조형 전문 연구기관)

종이접기, 색지공예, 한지그림, 전통지호·지승공예, 종이조각, 종이감기, 종이일러스트, 지끈공예, 리본아트, 종이장식, 비즈아트, 닥종이 조형, 북아트, 클레이아트, 클레이쿠기아트, 어린이북아트, 냅킨아트, 생활포장 강좌 운영

### ■ 부설 종이조형평생교육원 (국내 최고의 종이조형 전문 교육기관)

- 교양과 전문 교육을 통한 강사 자질 향상
- 교사 대상으로 하는 연수 프로그램 운영

### ■ 종이접기·종이문화 전시 및 세미나, 국제교류(컨벤션)

- 국내외 종이접기·종이문화 전시를 통한 교류 및 홍보
- 종이접기·종이문화 최신 정보를 제공하는 세미나 개최
- 코리아 종이접기 컨벤션 개최로 종이접기 전문가 및 애호가들의 국제교류 행사 진행

### ■ 공모전 개최

- ◇ 전국 종이조형작품공모전 : 어린이부 / 청소년부 / 일반부
- ◇ 코리아 종이접기 창작공모전

### ■ 『국가공인 종이접기 마스터 자격』지정기관

누구나 응시 가능한 『국가공인 종이접기 마스터 자격』지정기관으로 연 4회 검정시험 실시 (3월, 6월, 9월, 12월)

### ■ 종이접기·종이문화 민간 자격증 양성 자격 제도

- 일반 (17세이상) 과정 : 초급, 사범, 지도사범
- 지도사2급, 지도사1급, 전문지도사, 전문강사
- 청소년 초급, 사범, 지도사범(청소년 종이접기 박사)
- 어린이 종이접기 급수 과정 (3급, 2급, 1급 : 어린이 종이접기 박사)
- 유아 종이접기 급수 과정 (3급, 2급, 1급 : 유아 종이접기 박사)

### ■ 회원등록 안내

- 회원 등록비 : 연 3만원 (협회보 4권 발송)
- 문의 : 02)2264-4561

## The 10th KOREA ORIGAMI CONVENTION Diagrams Collection 2019

발행처 사단법인 한국종이접기협회

발행인 오경해

편집진행 이경구, 안현주

주소 서울특별시 중구 다산로 64

전화 (02) 2264-4561

팩스 (02) 2264-4565

홈페이지 <http://www.origami.or.kr>

© 사단법인 한국종이접기협회 2019

\* 이 책의 저작권은 (사)한국종이접기협회에 있으므로 무단 전재나 복제를 금합니다.



종이로 그리는 **꿈**  
종이로 담아가는 **예술**  
종이로 만드는 **아름다움**

(사)한국종이접기협회가 함께 합니다.