

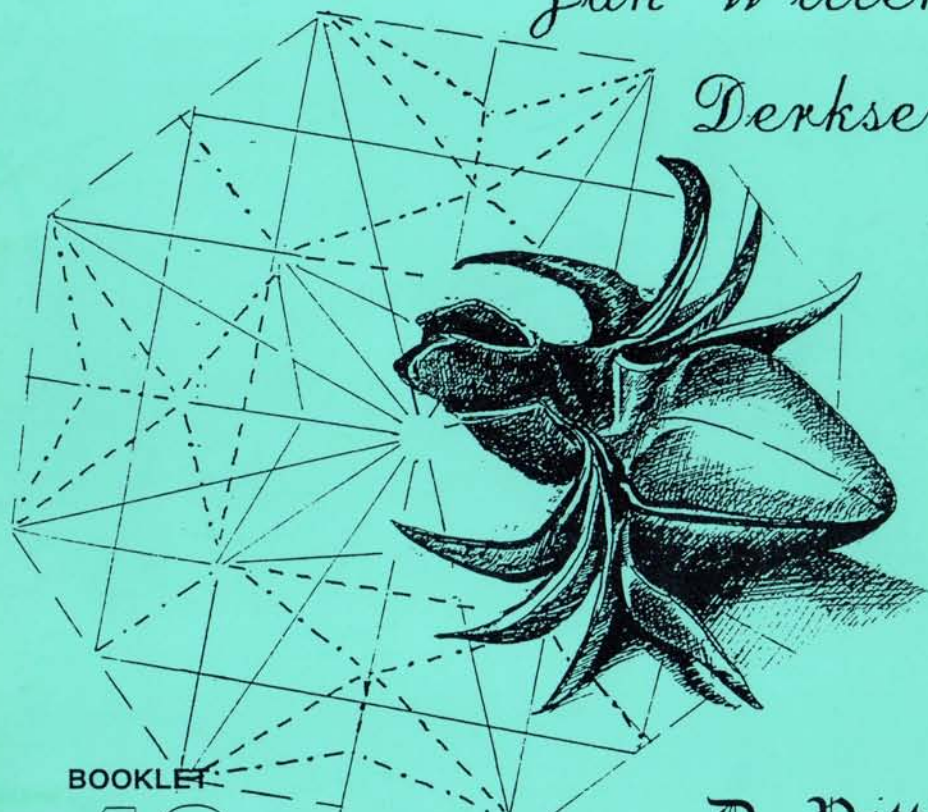

*The Genius
of
Jan Willem
Derksen*



BOOKLET

40

D. Petty

The Genius of Jan Willem Derksen

Page 1	11
Page 2	12
Page 3	13
Page 4	14
Page 5	15
Page 6	16
Page 7	17
Page 8	18
Page 9	19
Page 10	20
Page 11	21
Page 12	22
Page 13	23
Page 14	24
Page 15	25
Page 16	26
Page 17	27
Page 18	28
Page 19	29
Page 20	30
Page 21	31
Page 22	32
Page 23	33
Page 24	34
Page 25	35
Page 26	36
Page 27	37
Page 28	38
Page 29	39
Page 30	40
Page 31	41
Page 32	42
Page 33	43
Page 34	44
Page 35	45
Page 36	46
Page 37	47
Page 38	48
Page 39	49
Page 40	50
Page 41	51
Page 42	52
Page 43	53
Page 44	54
Page 45	55
Page 46	56
Page 47	57
Page 48	58
Page 49	59
Page 50	60
Page 51	61
Page 52	62
Page 53	63
Page 54	64
Page 55	65
Page 56	66
Page 57	67
Page 58	68
Page 59	69
Page 60	70
Page 61	71
Page 62	72
Page 63	73
Page 64	74
Page 65	75
Page 66	76
Page 67	77
Page 68	78
Page 69	79
Page 70	80
Page 71	81
Page 72	82
Page 73	83
Page 74	84
Page 75	85
Page 76	86
Page 77	87
Page 78	88
Page 79	89
Page 80	90
Page 81	91
Page 82	92
Page 83	93
Page 84	94
Page 85	95
Page 86	96
Page 87	97
Page 88	98
Page 89	99
Page 90	100

D. Petty

ACKNOWLEDGEMENTS

The BOS and the author express thanks to the Derksen family for their cooperation and permission to use the models in this book.

The author thanks Edwin Corrie and Jeff Beynon for proofing the diagrams. Let it be understood that if errors do remain then they are entirely the responsibility of the author.

The author thanks Mike Bridges who performed the thankless task of final shaping and publishing. The author thanks Enio Capra for permission to use his diagrams as a basis for the "Rabbit".

The author thanks Lilian Petty for the cover design.

© D Petty
October 1992

First Published October 1992
B.O.S. Booklet No 40

No part of this publication may be reproduced, stored in a retrieval system, or transmitted, in any form or by any means, electronic, mechanical, photocopying, or recorded or otherwise, without the written permission of the British Origami Society.

Printed in the United Kingdom

CONTENTS

MODEL	PAGE
Bear	1
Beetle	3
Beetle, Long Horned	4
Bird	8
Butterfly	9
Cube, Penetrating (modular)	11
Decoration 3D	14
Dodecahedron, Star Patterned	16
Eagle	18
Eagle 2	20
Farm Horse	22
Flower	25
Fly	26
Football, Single Piece	29
Form, Geometric	31
Gemini	33
Horse Head (with halter)	39
Lion	41
Mushroom	42
Pyramid	43
Rabbit	45
Sailboard	47
Solids, Dimpled Geometric (modular)	50
Sparrow	52
Spider	55
Stand (and Icosahedron)	57
Star, Christmas	58
Star, 8 Point	59
Tray, Three Compartment	61
Trophy, Stag Head	65
Two Swans	68
Other British Origami Society books	68
Further information about the Society	69

BEA INTRODUCTION.

Many readers will not be familiar with the name of the creator of the origami in this book. This is understandable, since Jan Willem Derksen lived in Holland. He was virtually isolated from rest of the world origami community. It is important to remember this when appreciating his models. On first contact, I was immediately impressed by the technical standard of his folding and creating. In this book is the entire collection of his known work.

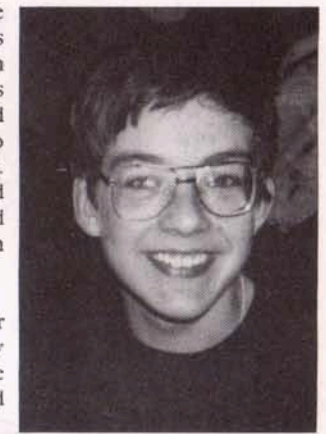

The models will, of course, speak for themselves. I would simply add that they range from simple to complex. They are arranged in alphabetical order, without regard to their complexity, in this publication.

I would like to draw to the readers attention the technique used in the models "Gemini" and "Spider" to produce the required number of points. [Birdbase surrounded by rectangular areas that have a near-birdbase crease pattern]. This is a new technique to the author and clearly marks the creator as innovative in the field of technique as well as model creation.

This would have been entirely a purists' book except for the inclusion of two models that do require gluing in the final assembly. My arguments for their inclusion are: that it is relatively simple to avoid most of the gluing [by starting with modified paper sizes] and that they provide a starting point for others to attempt to improve on.

The diagrams in this book have mostly been made directly from original models in the absence of original diagrams. Because of this, the final model is authentic but the folding sequence may vary from the original. In those cases where there were alternatives the simplest method has been diagrammed.

I thoroughly recommend folding the models in this book. Some are truly stunning. The quality of the models kept me going through the times when drawing diagrams seemed impossible and understanding the folding sequence would have defeated an Einstein. I know that you will agree with me if you give the models a go.

D.Petty.
10/9/92



This model will not be built with the
use of the center of the square in the
case of the square. This is important, since the
When folded back in the middle the
model, especially if it is important to
remember the which appearance in model.
(The model I was shown, impressed
by the texture, made of a folding and
created at the back a the same collection
of the same way.

The model will of course speak for
itself. I would suggest that the
steps from square to complete. They are
described in the order, without regard
to their complexity, in the picture.

I would like to refer to the model in the technique used in the
model. (The model, and the model, are the same number of points
The model is described in the order, and the model, are the same
as in the model, and the model, are the same as in the model.
The model is described in the order, and the model, are the same
as in the model, and the model, are the same as in the model.

The model has been built a point, but except for the incision of two
model, the model, are the same as in the model, and the model,
The model is described in the order, and the model, are the same
as in the model, and the model, are the same as in the model.

The diagrams in this book have mostly been made directly from original
models in the shape of original papers. Because of this, the final model
is different, but the folding sequence may vary from the original. In these
cases where there were differences, the original model, the final
diagram.

The model is described in the order, and the model, are the same
as in the model, and the model, are the same as in the model.
The model is described in the order, and the model, are the same
as in the model, and the model, are the same as in the model.

© Bear
1992

BEAR

Use thin paper. Original in brown.

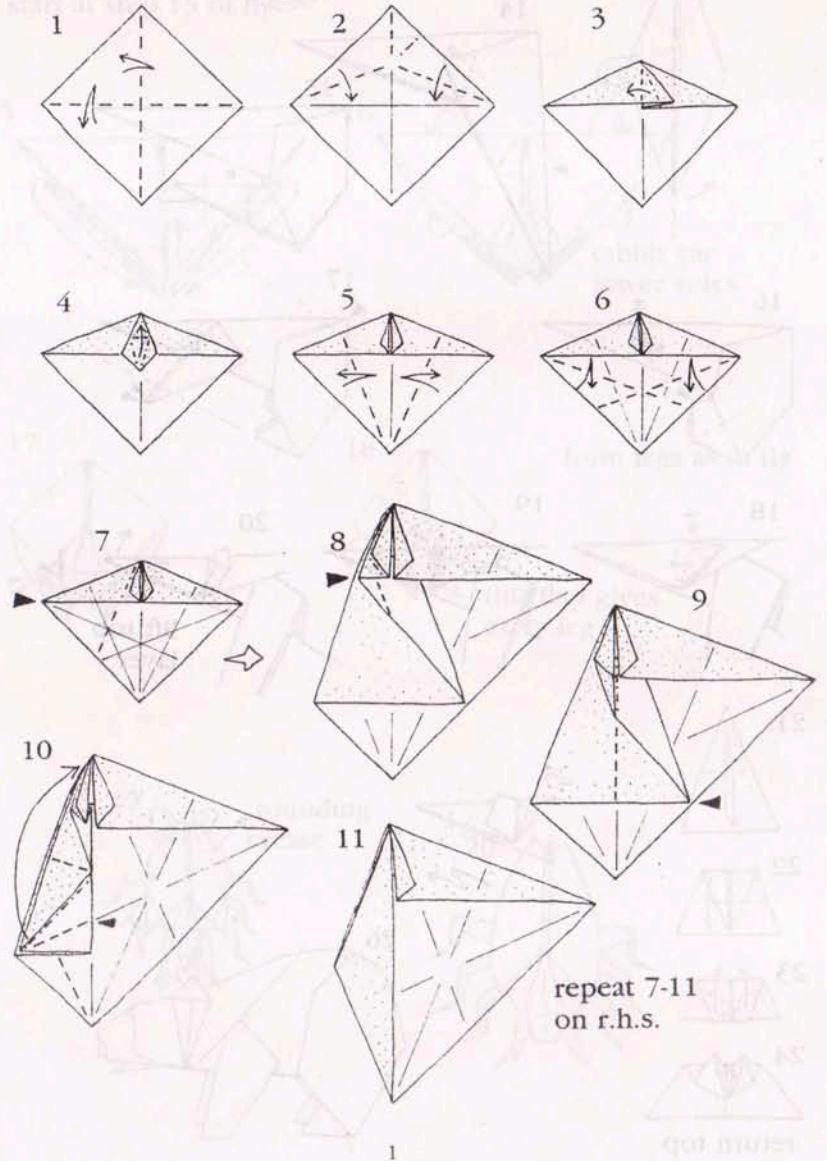

repeat 7-11
on r.h.s.

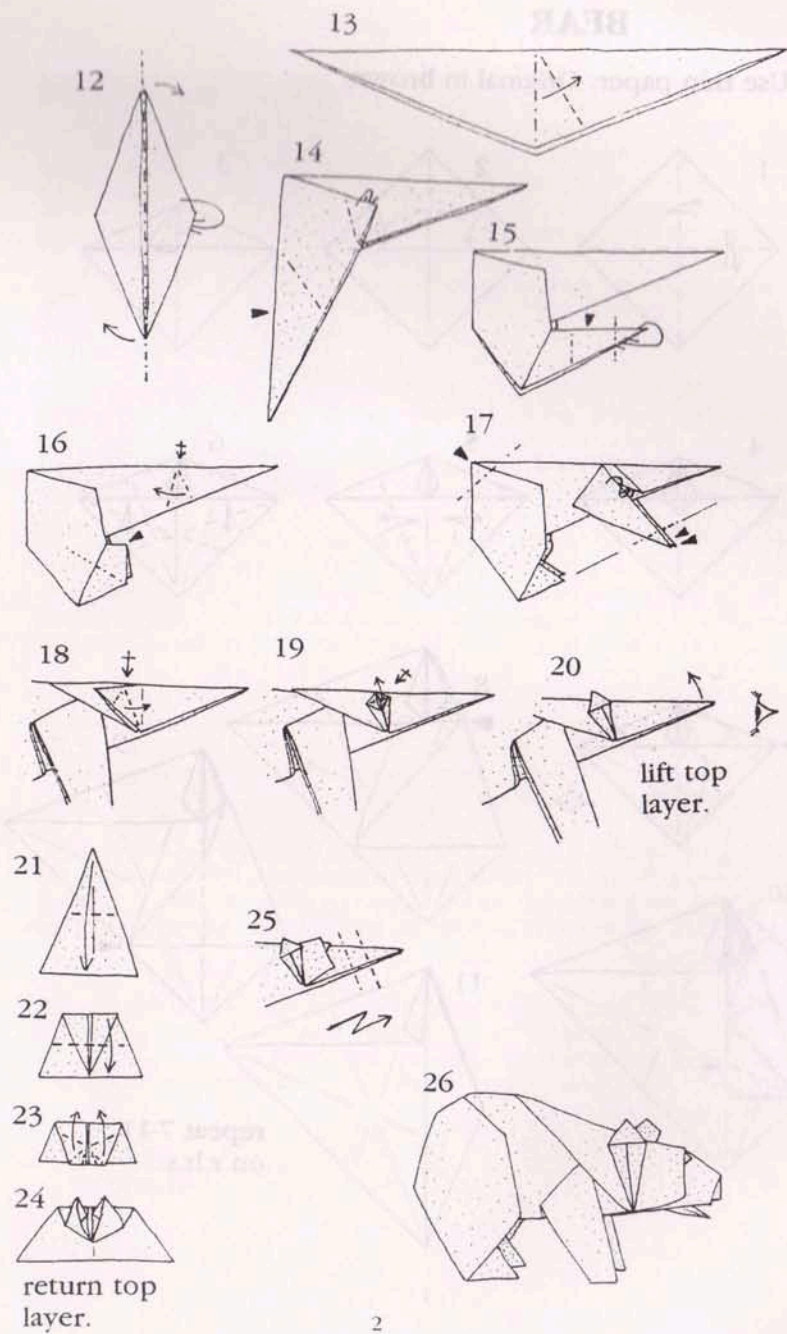

BEETLE

Use foil or tissue covered foil. Original in black and red.

start at step 15 of fly

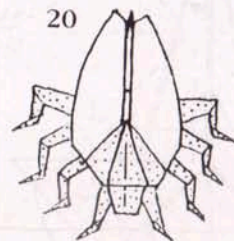
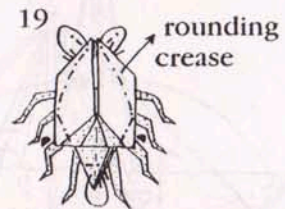
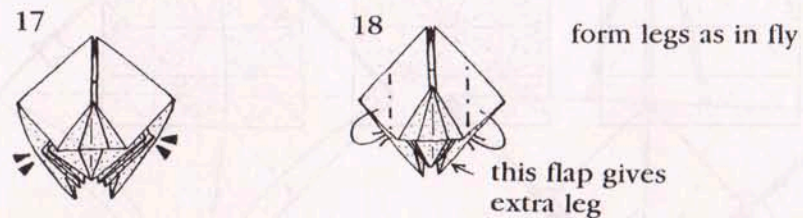
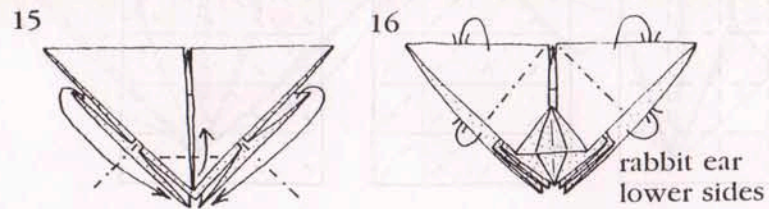

LONG HORNED BEETLE

Use thin foil or tissue covered foil. Original in green.

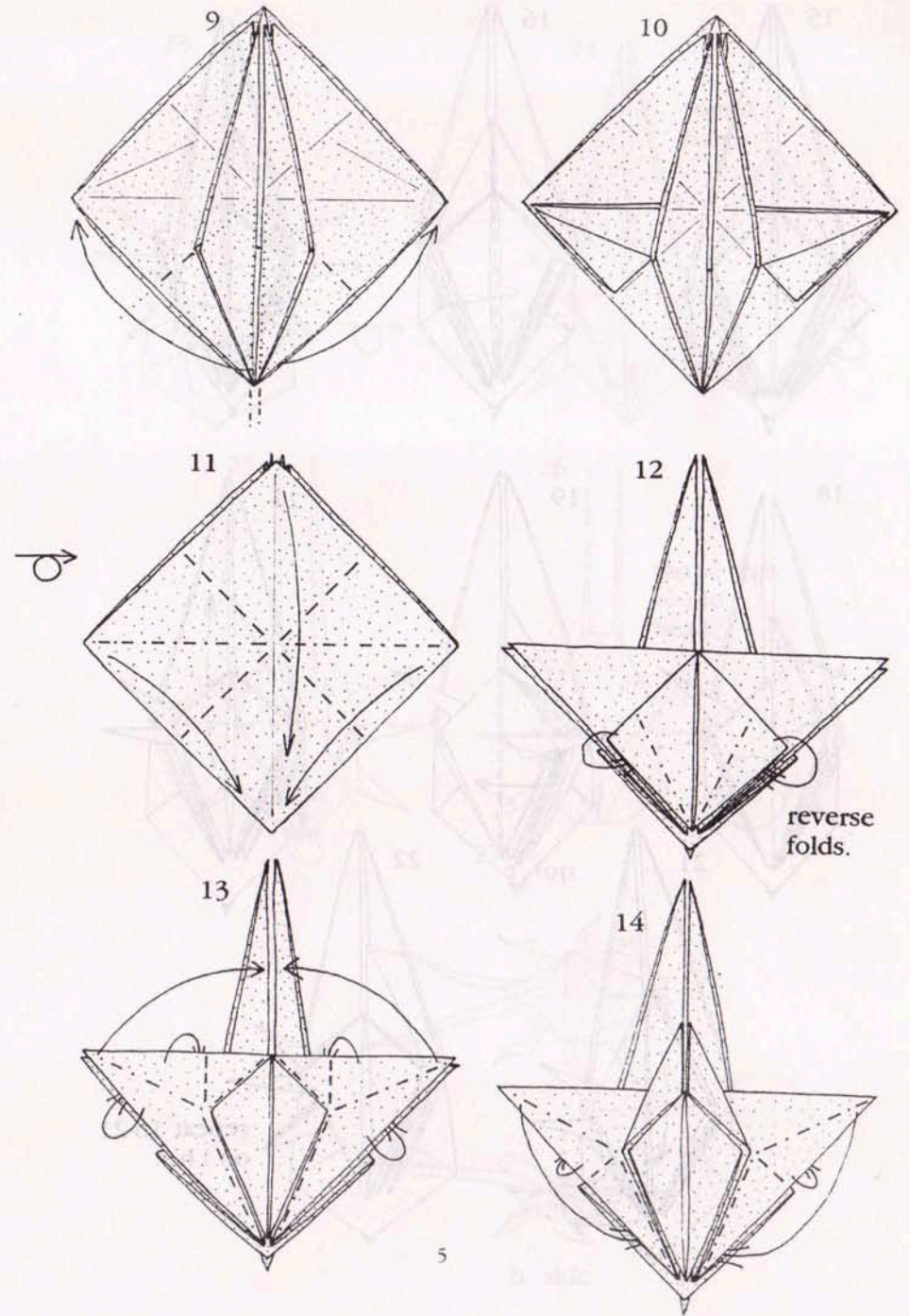
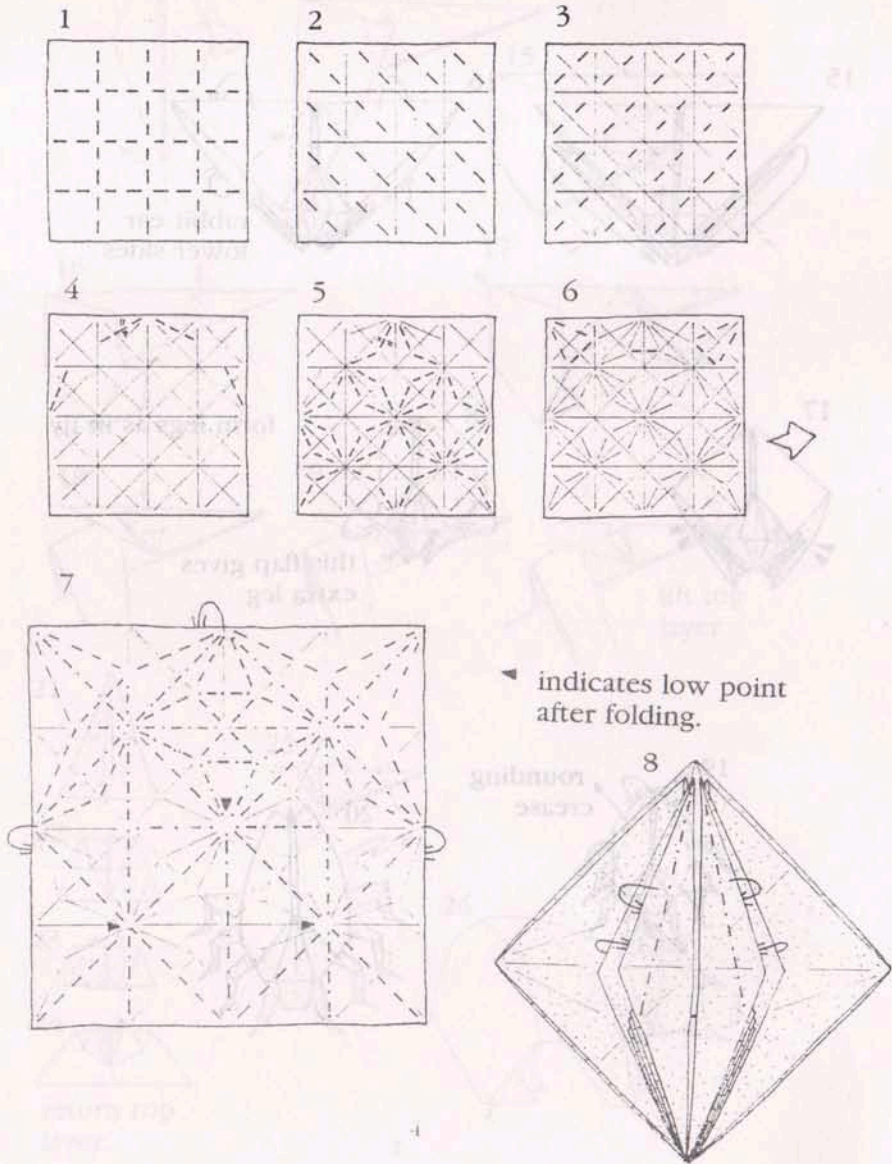

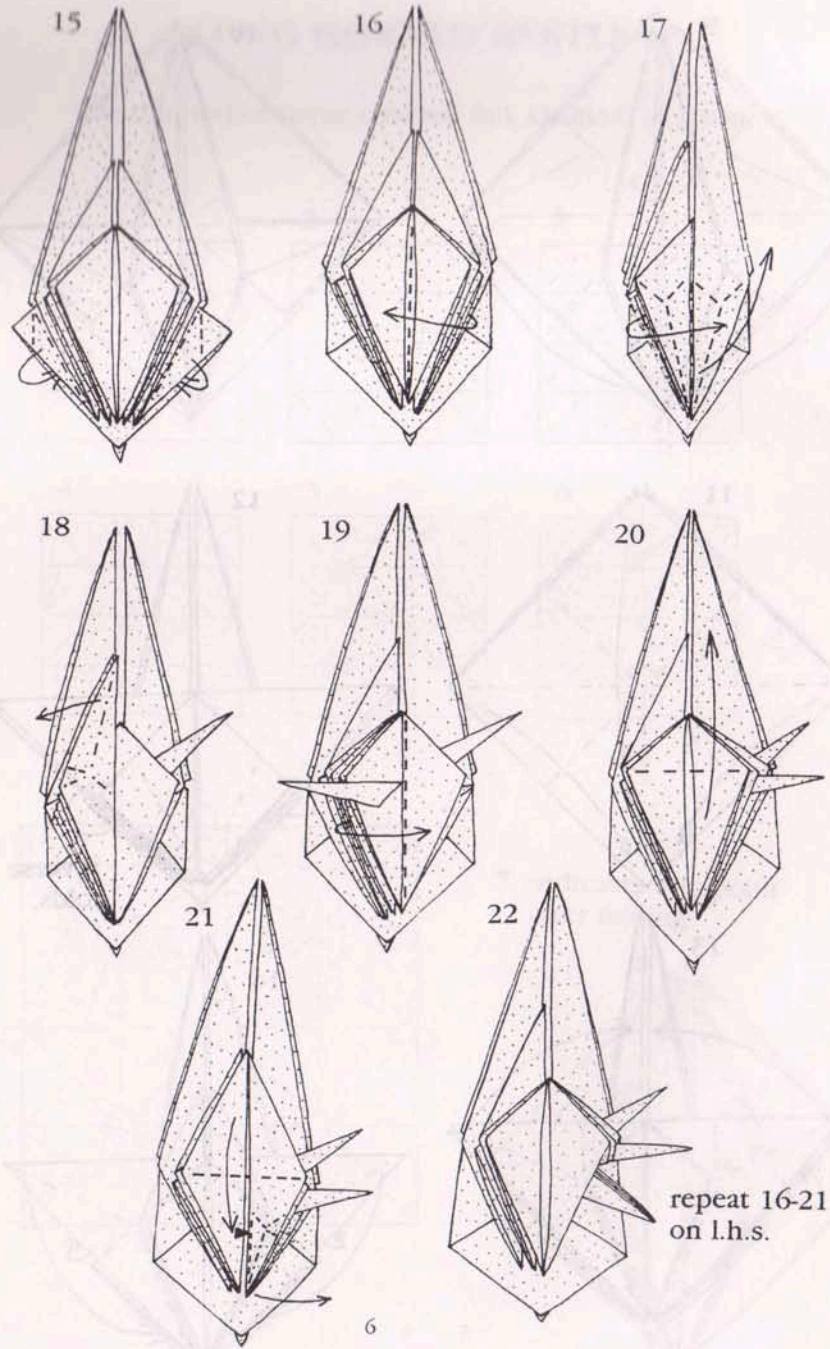

6

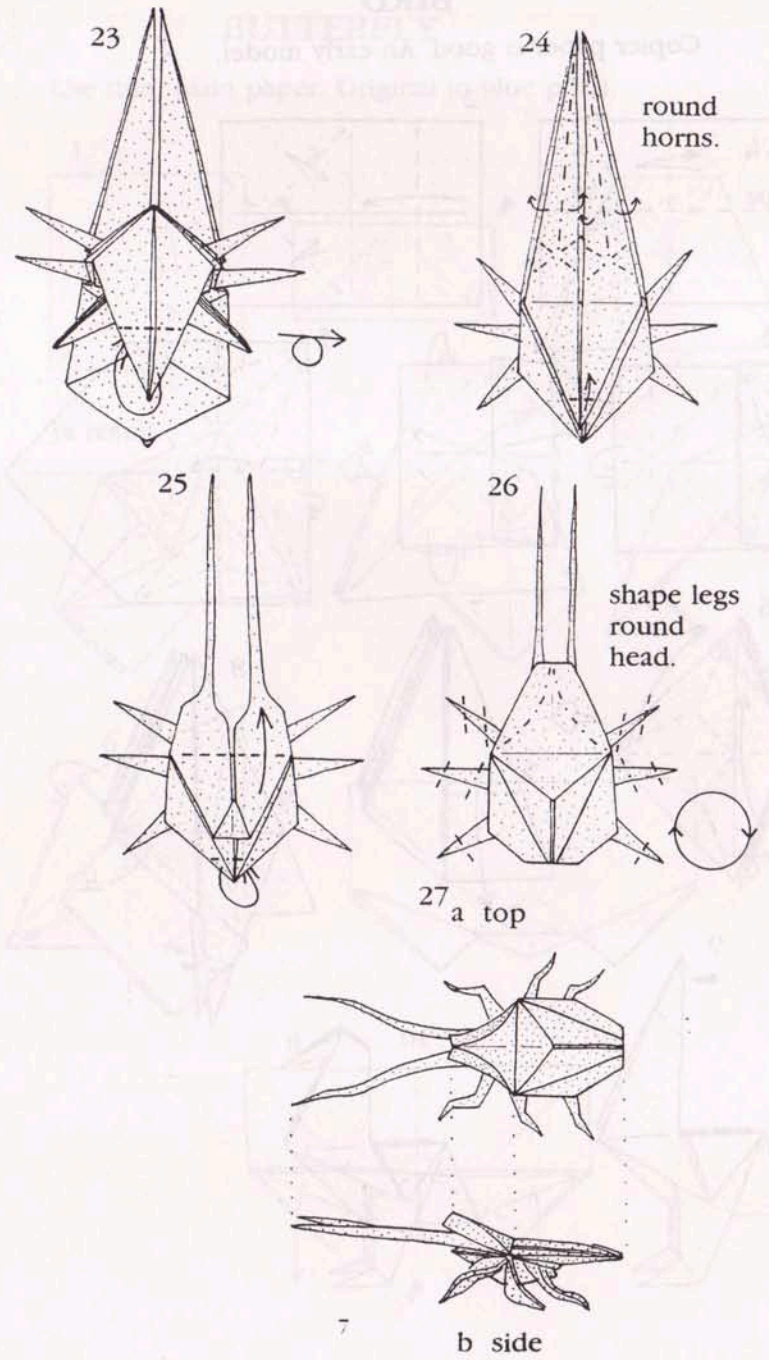

7

BIRD

Copier paper is good. An early model.

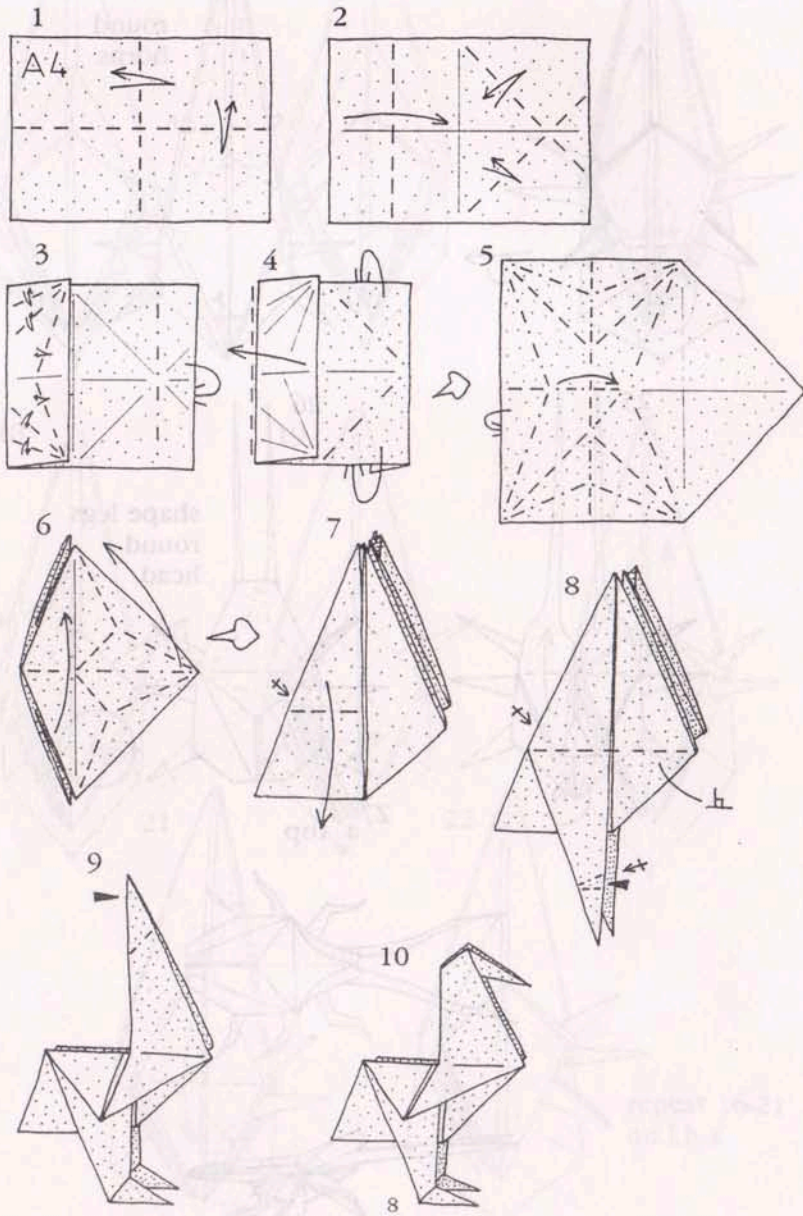

BUTTERFLY

Use thin, plain paper. Original in blue pearl.

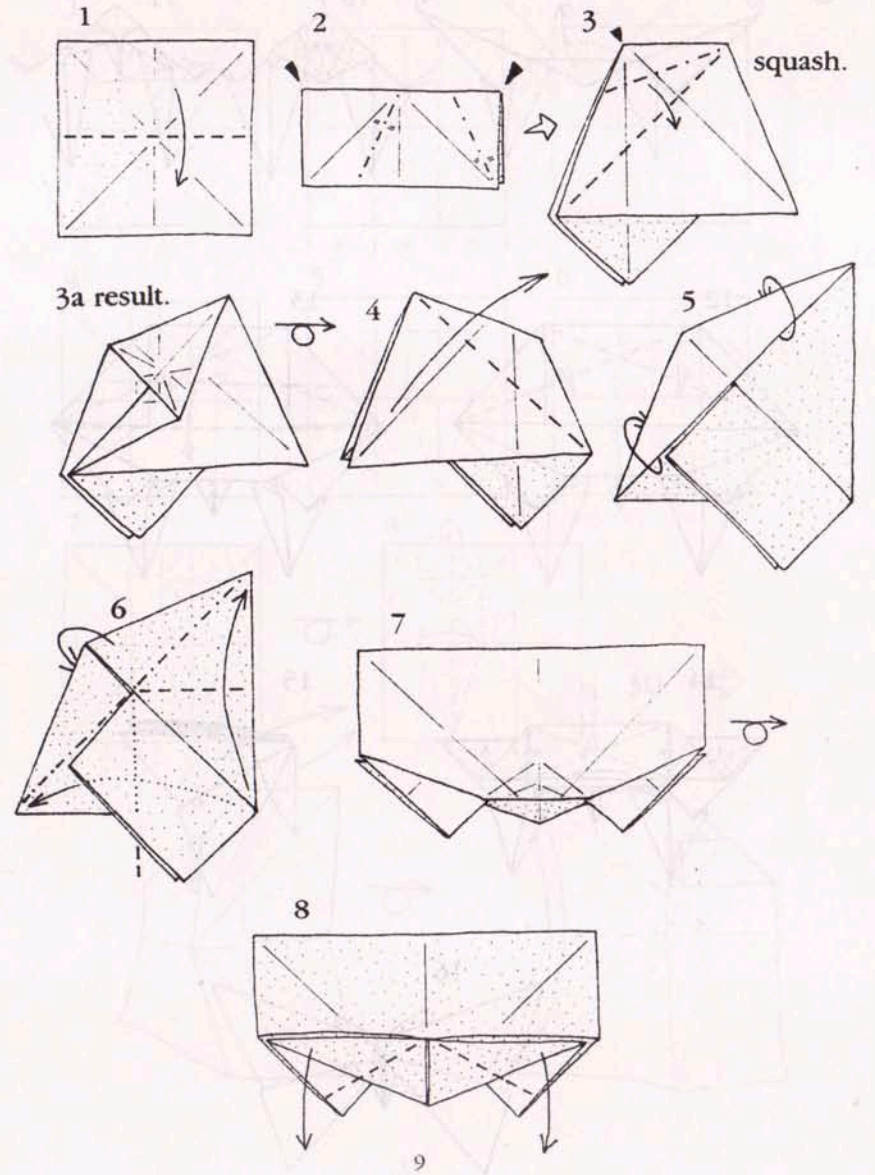

PENETRATING CUBE MODULE

Use plain paper in 2 contrasting colours.

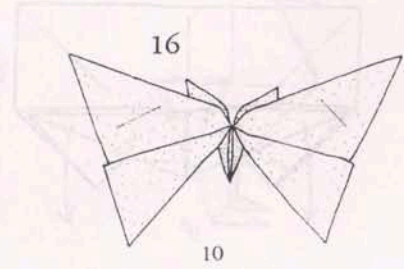
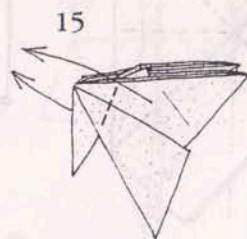
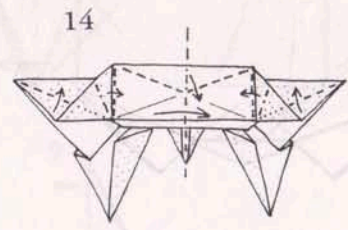
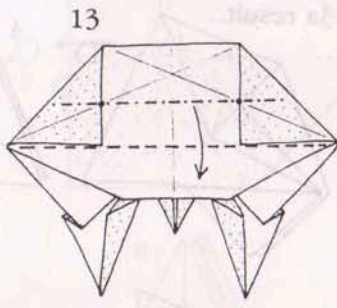
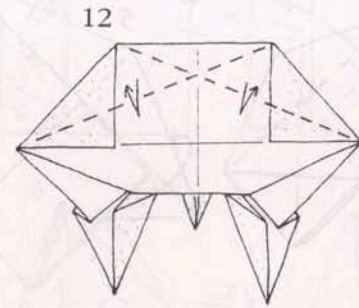
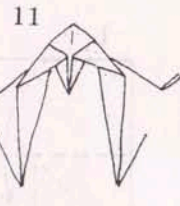
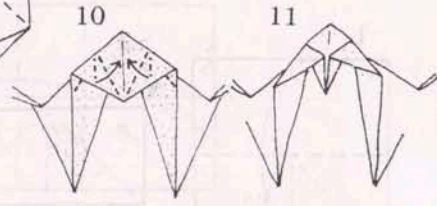
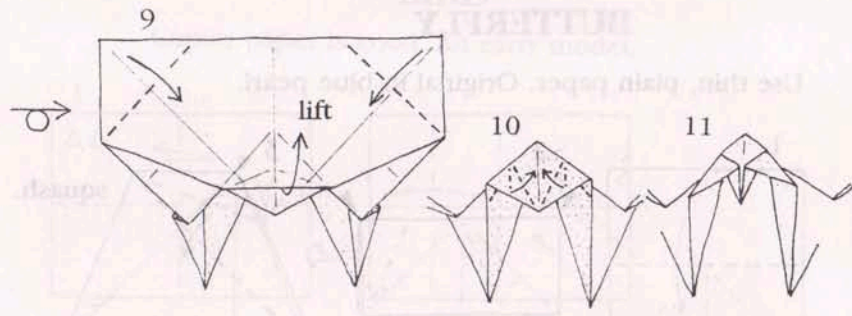

10

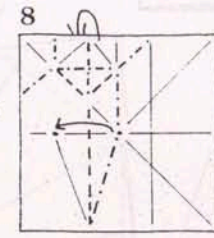
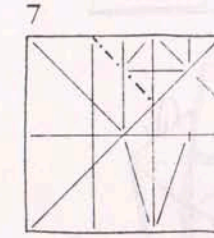
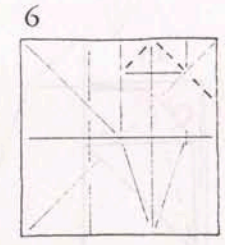
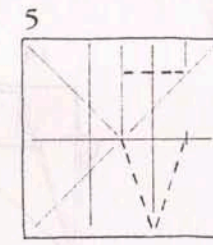
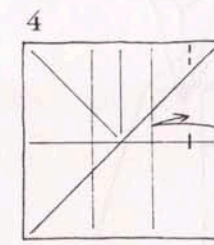
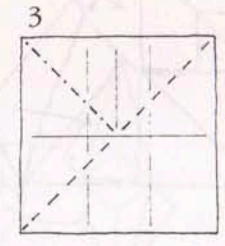
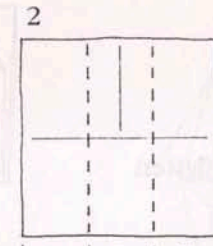
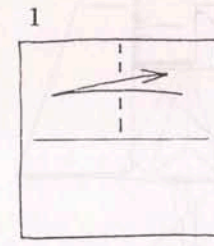

3D. →

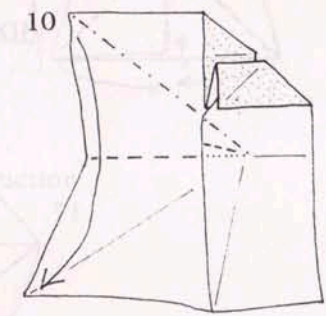
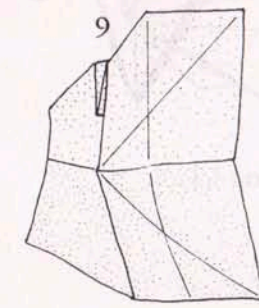

11

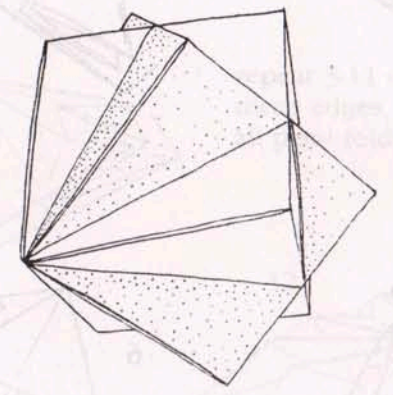
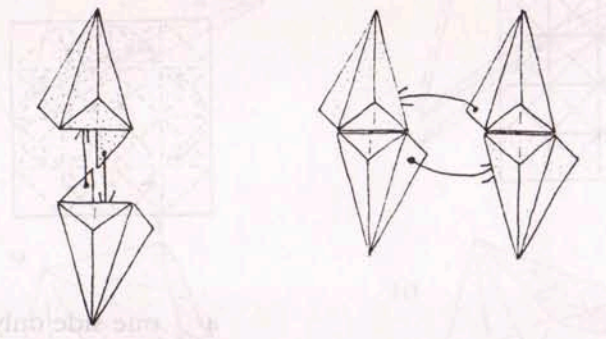
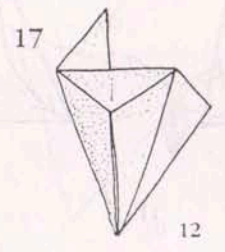
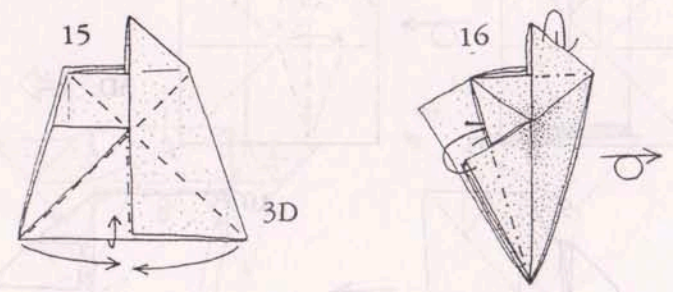
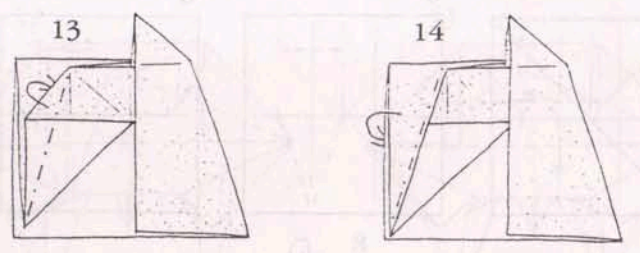
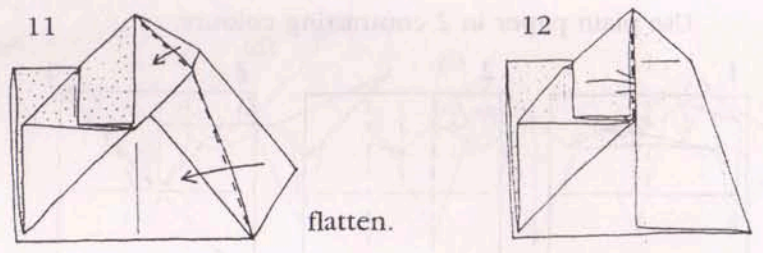

12 unit construction.

3D DECORATION

Use plain, strong, stiff paper. Original in green.

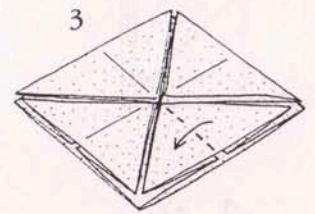
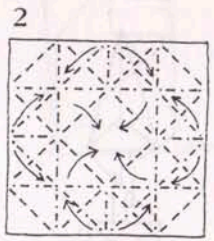
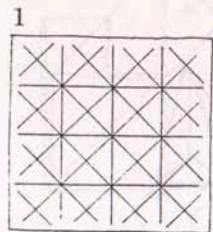

4 one side only shown.

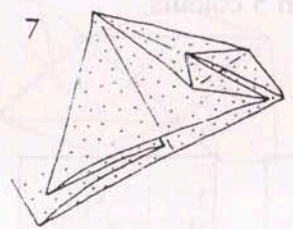
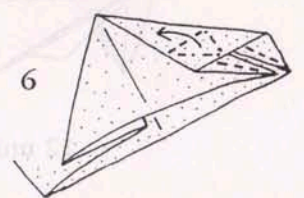
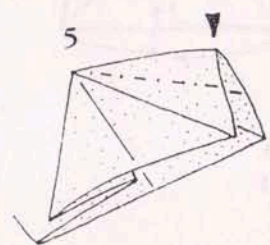
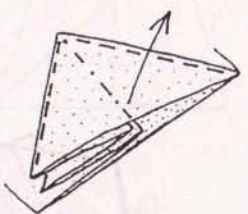

unfold to step 3,
repeat 3-7 on l.h.s.

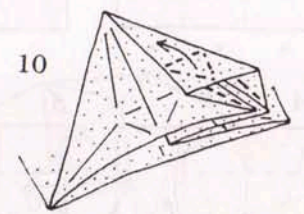
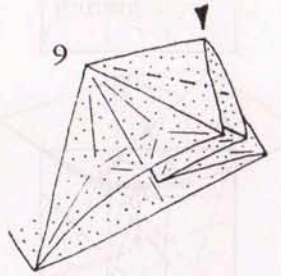
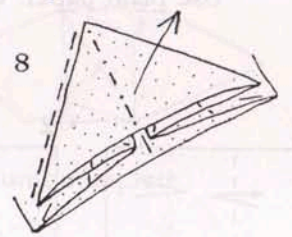

repeat 3-11 on the other
three edges, then refold
all petal folds.

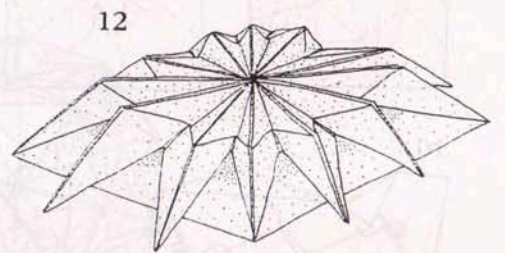
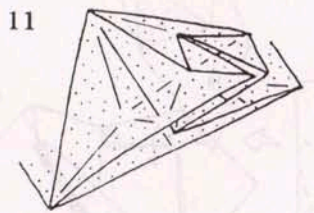

STAR PATTERNED DODECAHEDRON

Use plain paper. Original in 5 colours.

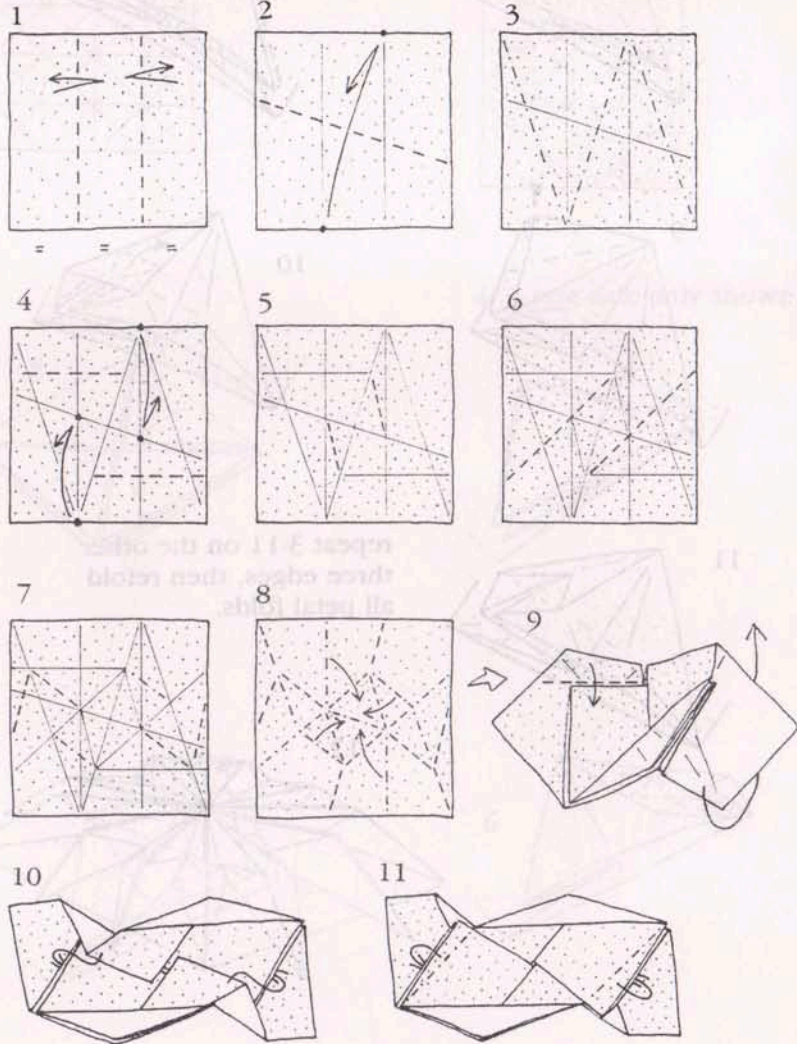

16

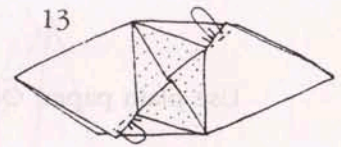
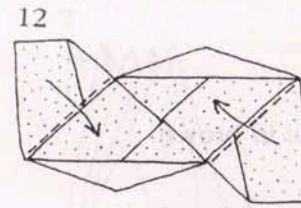

unit complete.

joining.

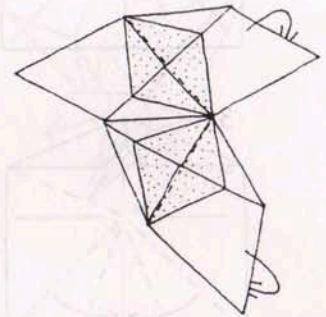
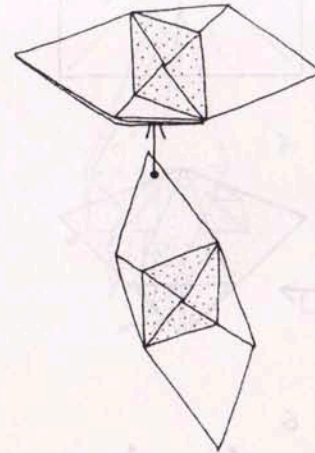

assemble in rings of 5,
mountain fold as shown.

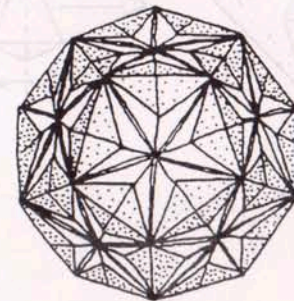

30 unit dodecahedron

EAGLE

Use plain paper. Original in brown.

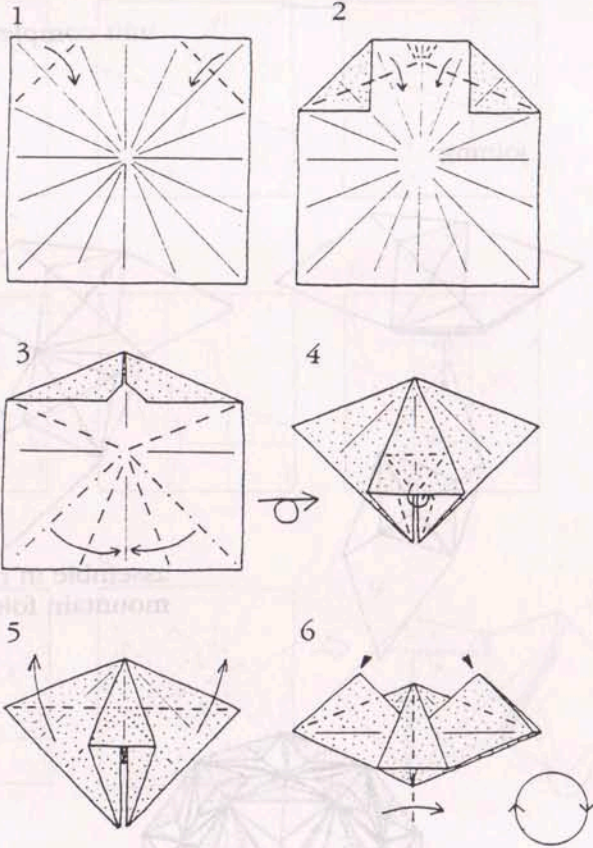

18

EAGLE 2

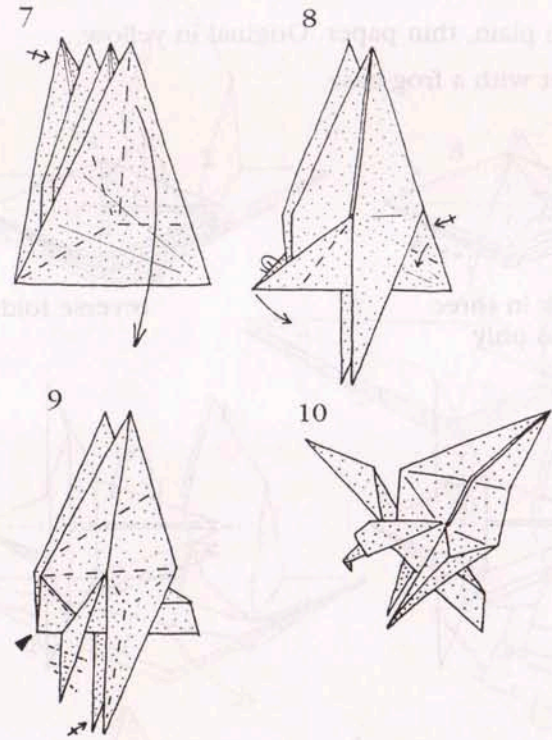

19

EAGLE 2

Use plain, thin paper. Original in yellow.
start with a frog base.

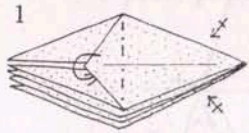

tuck in three flaps only.

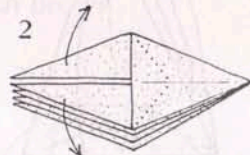

reverse folds.

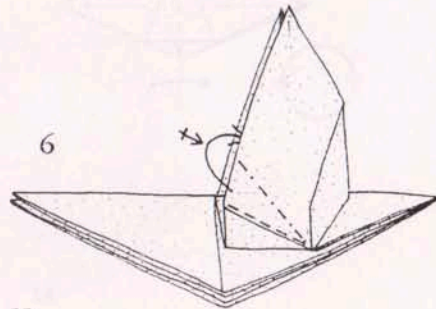
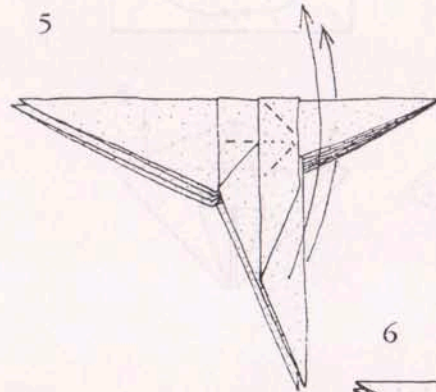
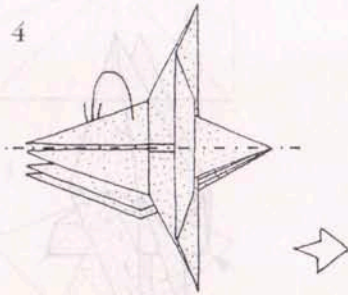
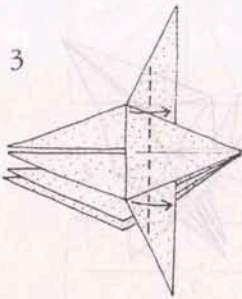

20

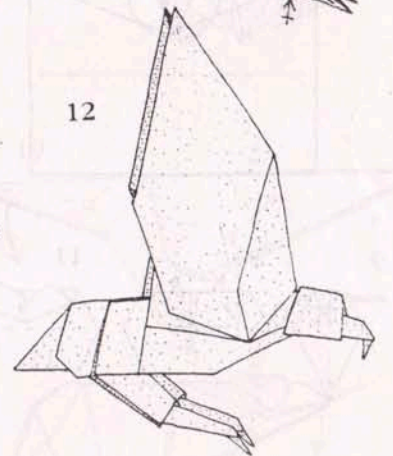
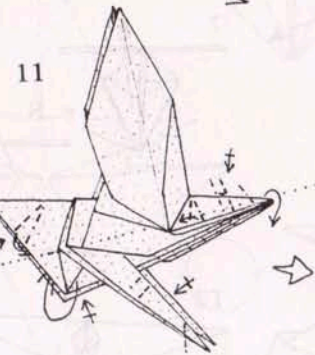
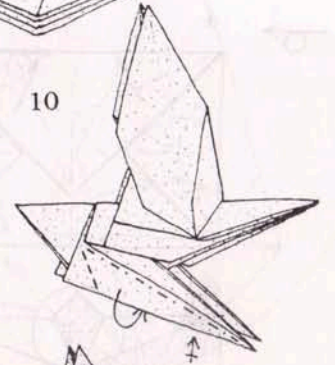
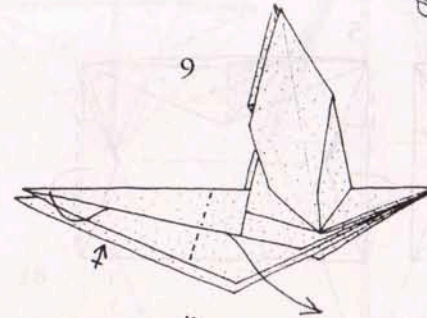
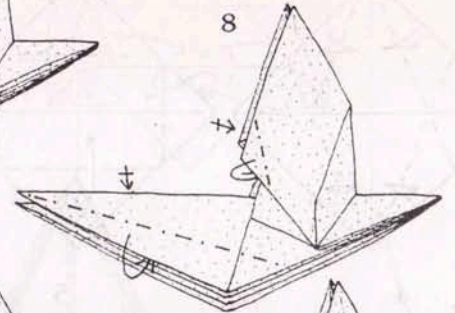
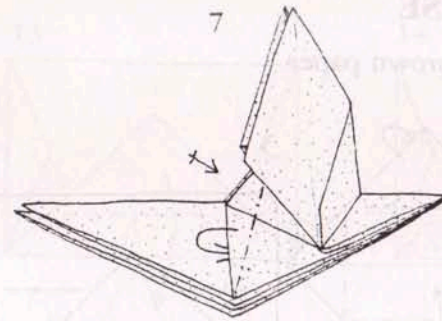

21

FARM HORSE

Use thin paper. Original in brown paper.

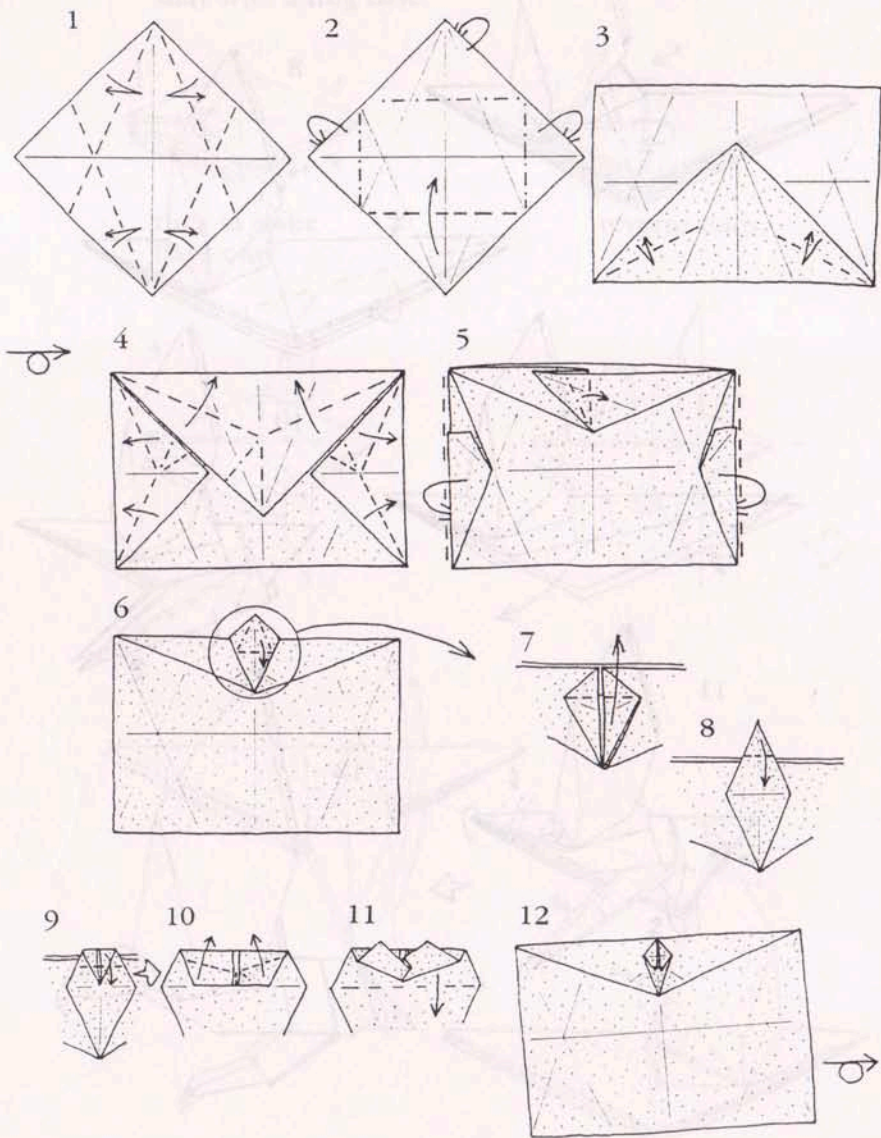

FLOWER

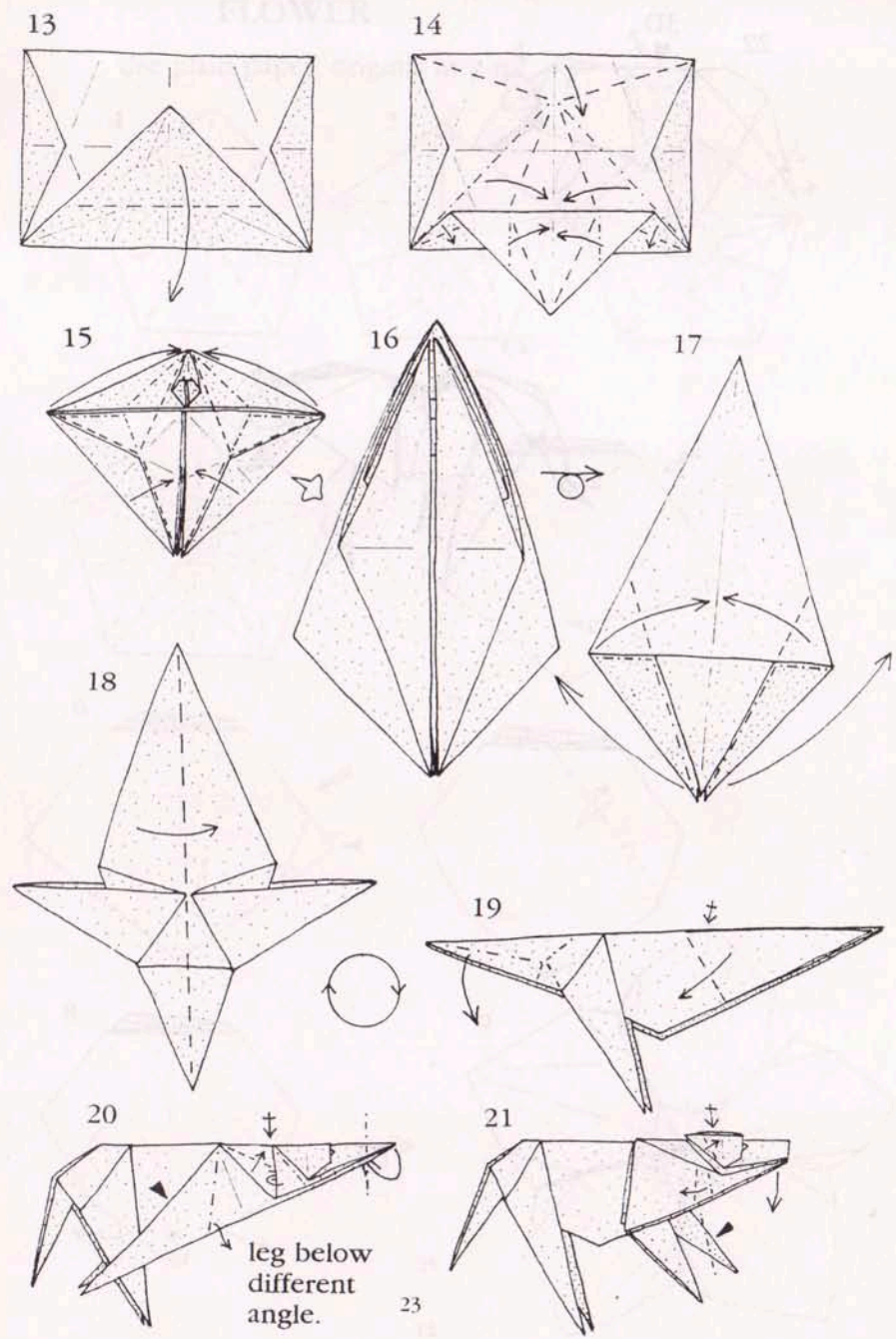

leg below
different
angle.

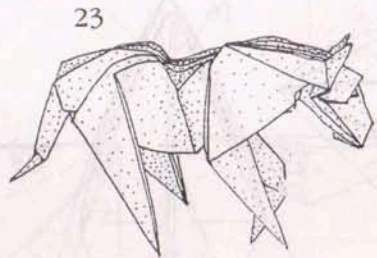
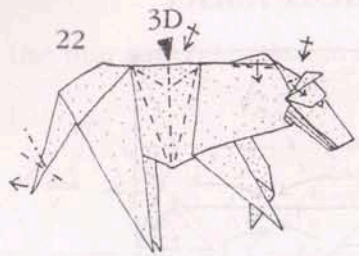

FLOWER

Use plain paper, original in pink

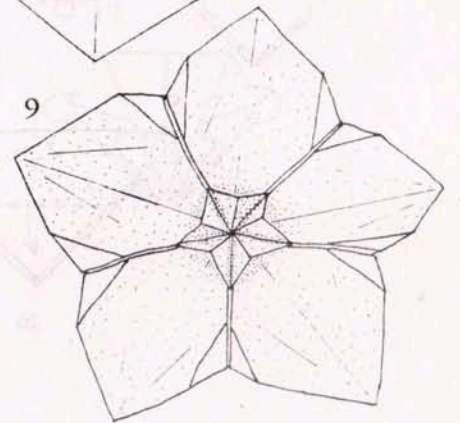
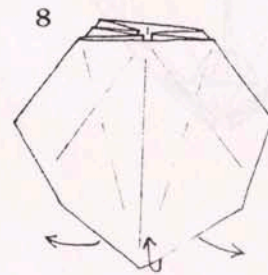
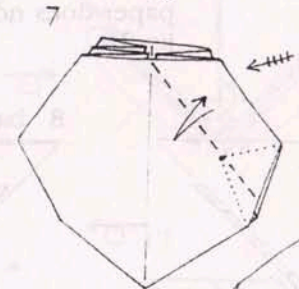
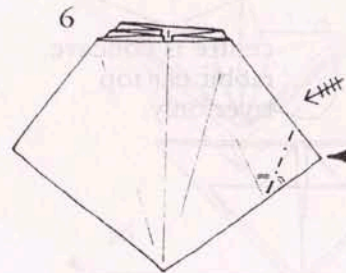
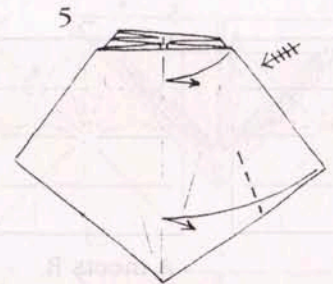
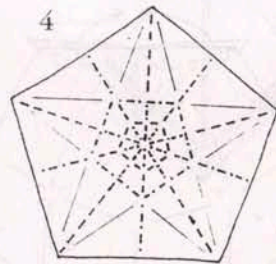
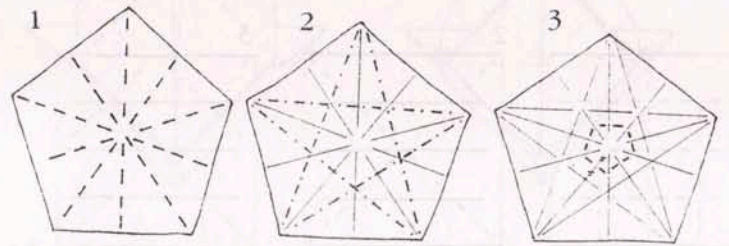

FLY

Use plain, thin paper. Original in black.

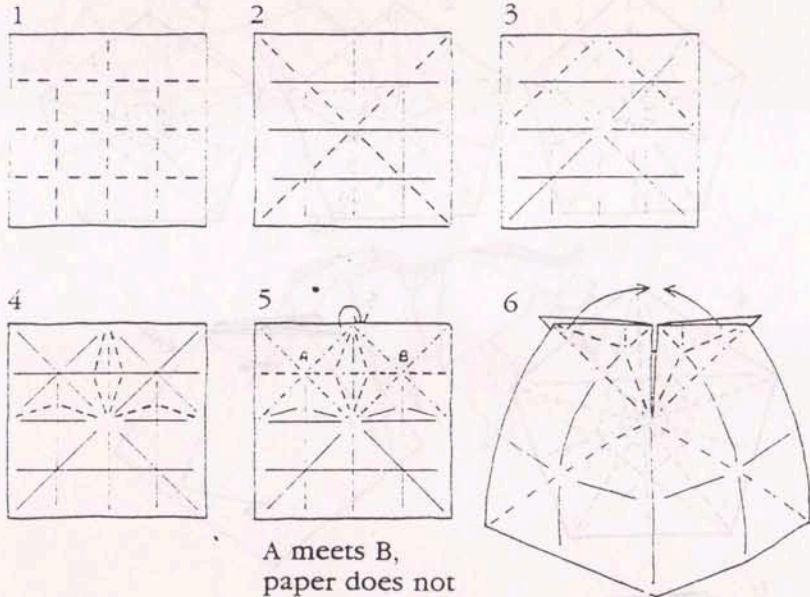

A meets B,
paper does not
lie flat.

centre is concave,
rabbit ear top
layer only.

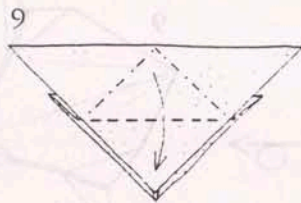
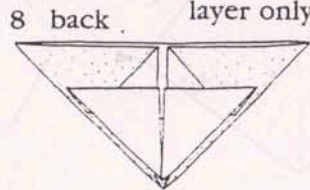
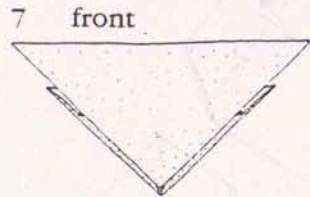

26

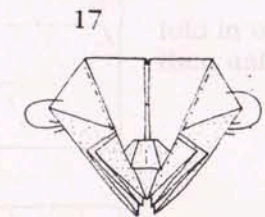
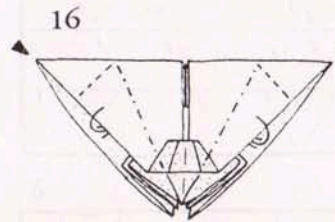
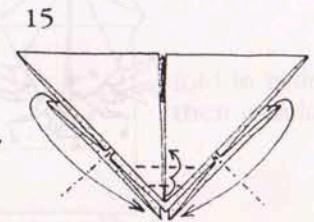
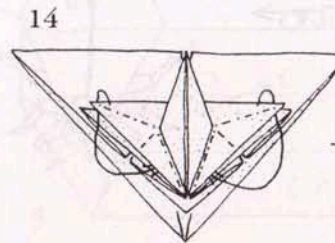
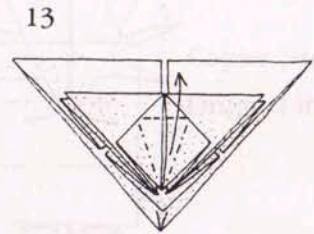
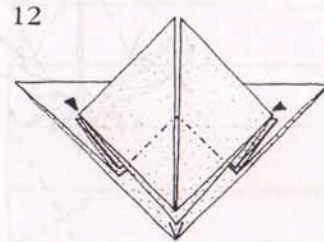
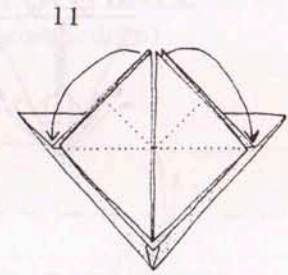
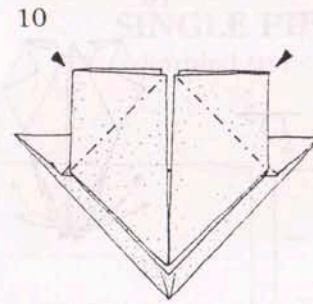

27

18

FLY

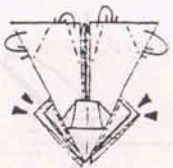

19

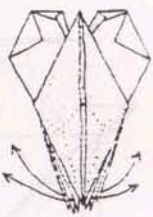

20

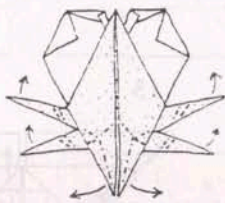

21

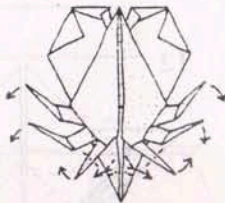

22

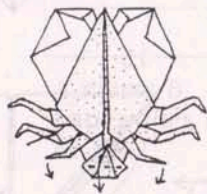

23

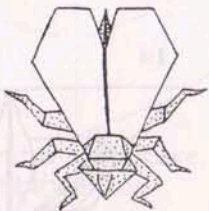

28

SINGLE PIECE FOOTBALL

(dimpled truncated icosahedron)

1

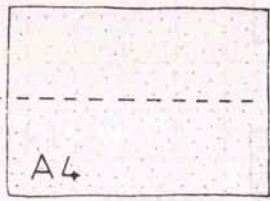

2

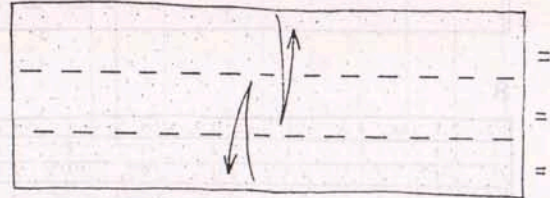

3

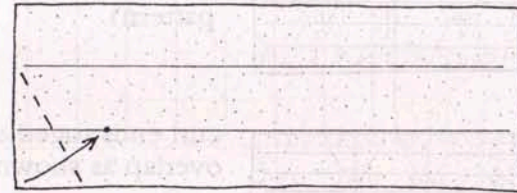

Copier paper is good.
Original in yellow.

4

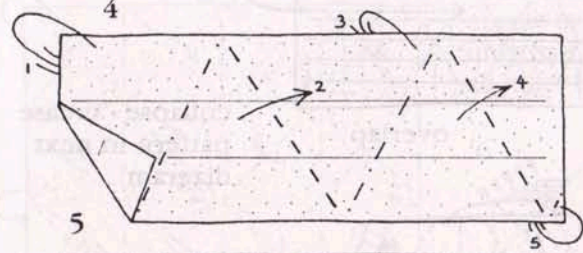

fold in order shown,
then unfold.



fold in order shown,
then unfold.

6

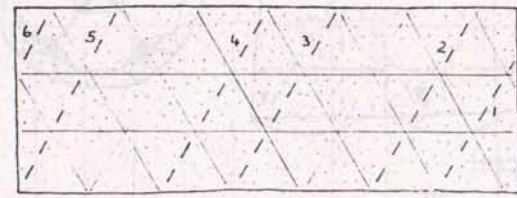

fold in order shown,
then unfold.

29

cut ends together

7

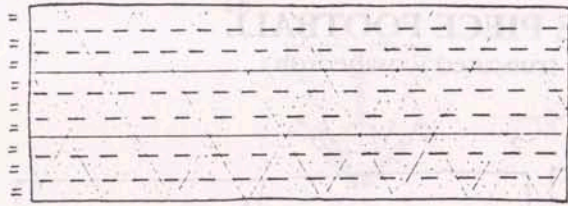

precrease.

8

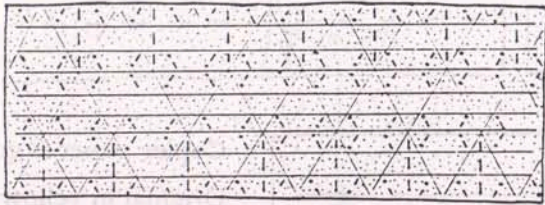

precrease
(honeycomb
pattern).

9

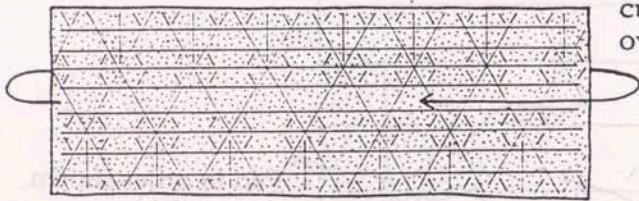

curl ends together,
overlap as shown.

overlap

collapse - crease
pattern in next
diagram

10

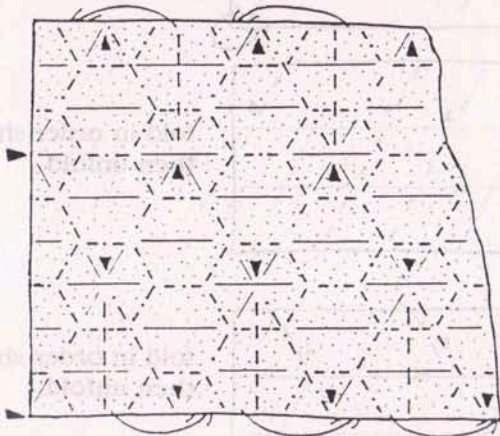

persevere!

30

11

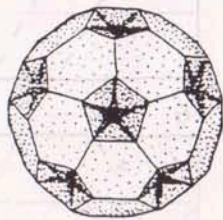

GEOMETRIC FORM

Use strong paper. Original in harmony.

1

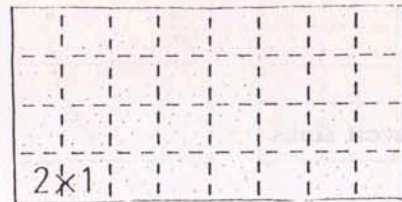

2



3

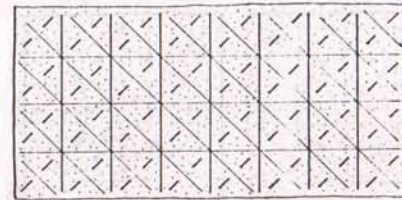

4

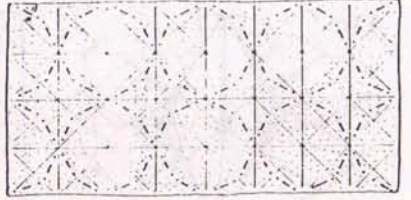

5

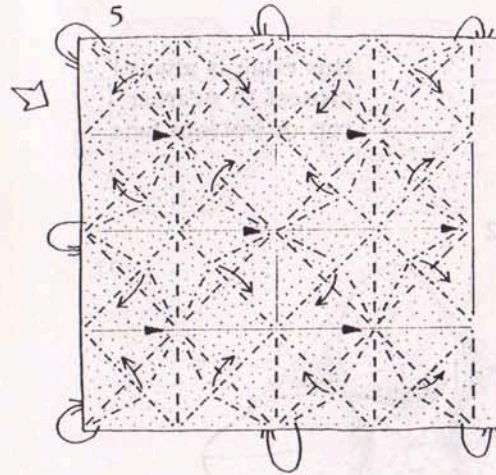

collapse following
crease pattern in step 5.
only half paper shown,
all must be folded.

6

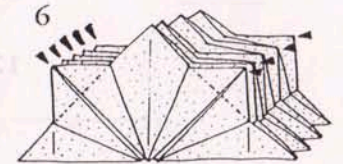

7

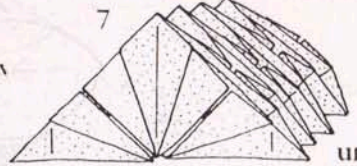

unfold.

8

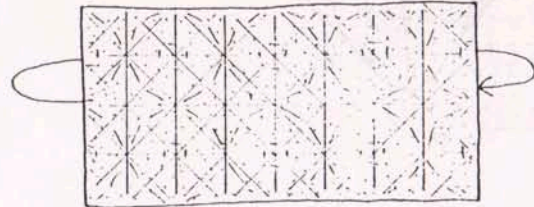

curl ends together

9

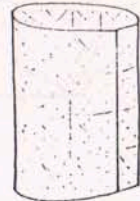

fix into
cylinder
(glue).
N.B. no
overlap.

31

collapse cylinder following crease pattern in step 5.

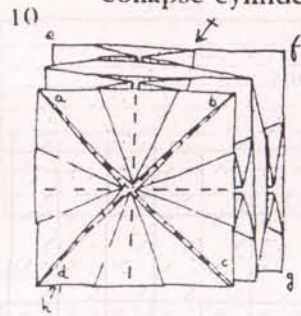

convert sinks

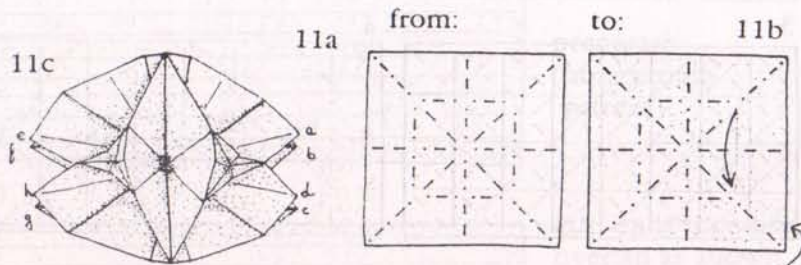

a,b,c,d meet.
e,f,g,h meet.
glue them together for
final shape.

this edge is always
closest to nearest
top or bottom face.

12

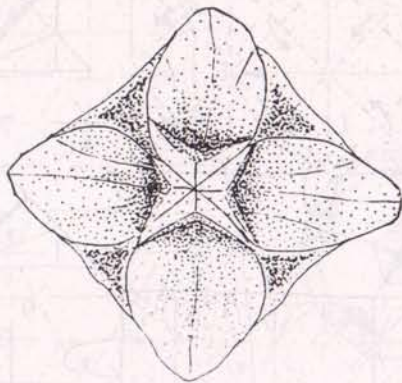

32

GEMINI

Use stiffish, thin paper. Original in green.

1 pinches.

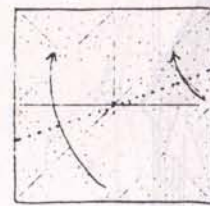

2

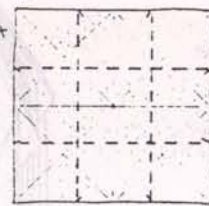

3



4

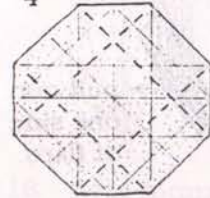

5

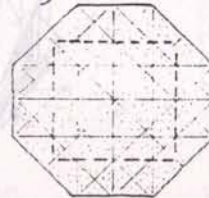

6



7

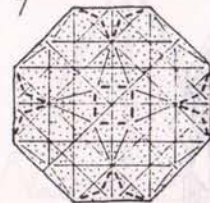

8

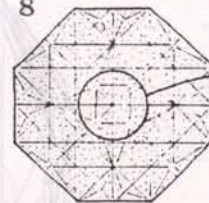

9

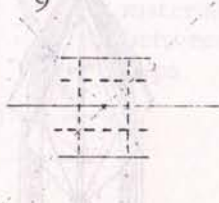

10

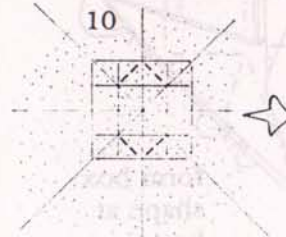

11

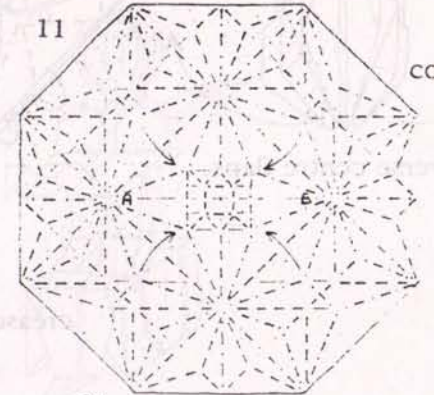

collapse.

A meets B.

33

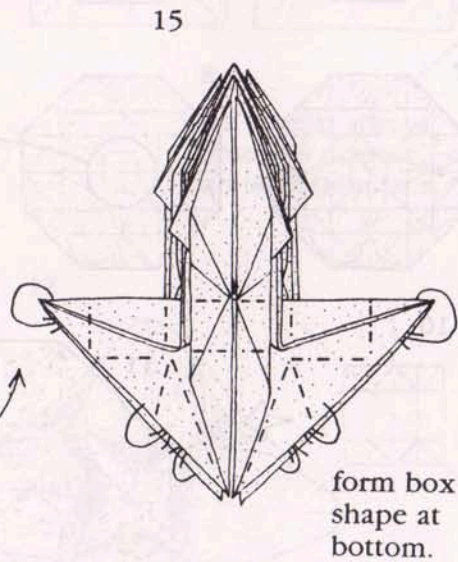
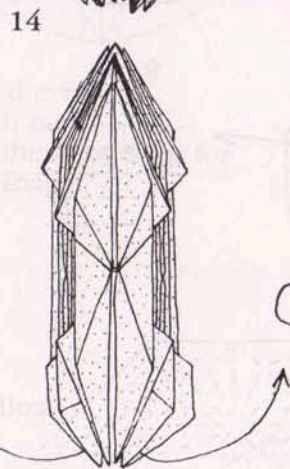
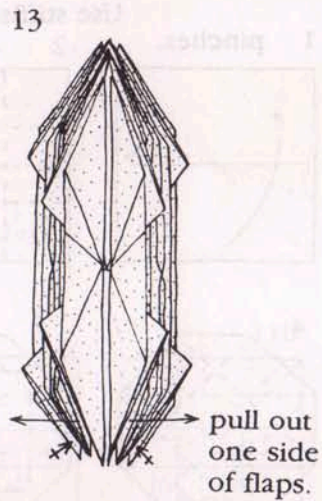
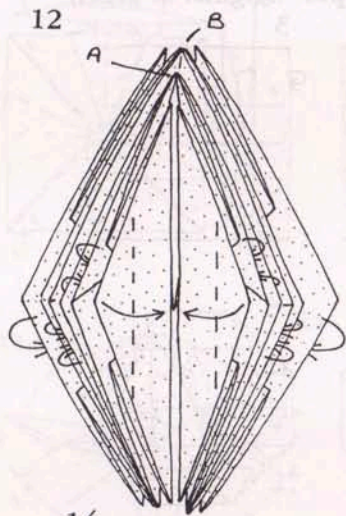

creases repeat at rear.

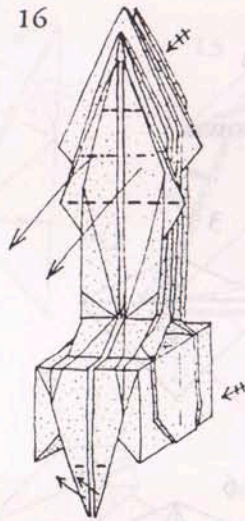

18 head formation.

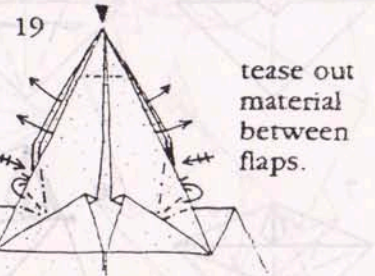
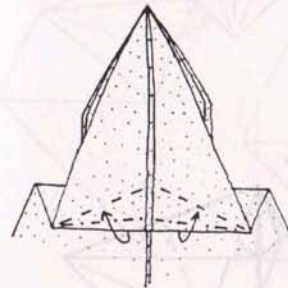

HORSE HEAD (with halter)

Use plain, thin paper. Original in light brown.

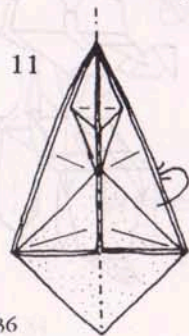
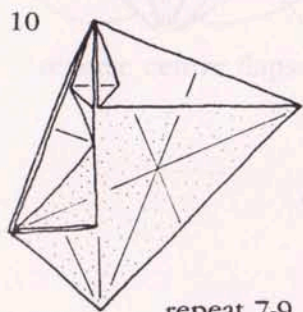
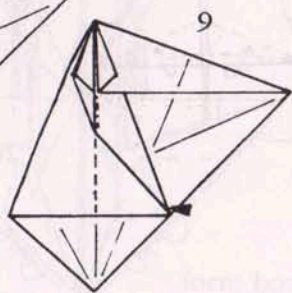
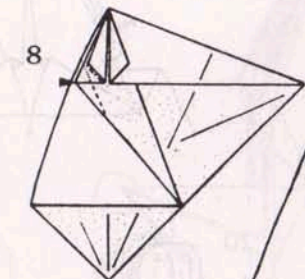
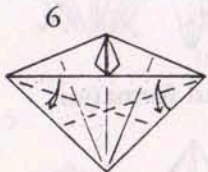
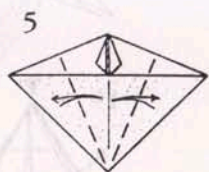
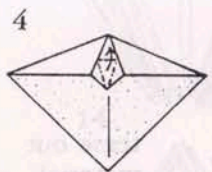
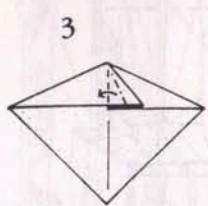
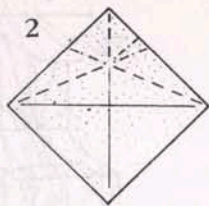
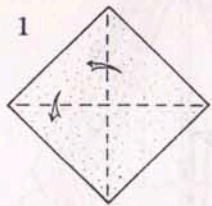

repeat 7-9
on r.h.s.

36

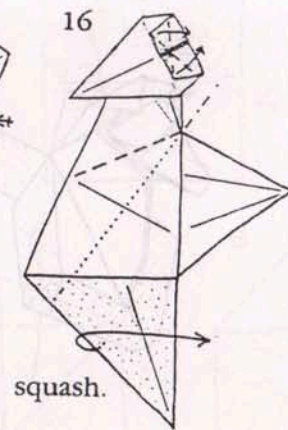
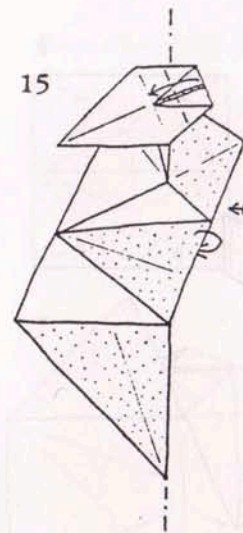
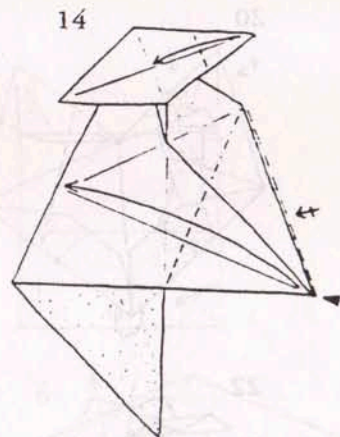
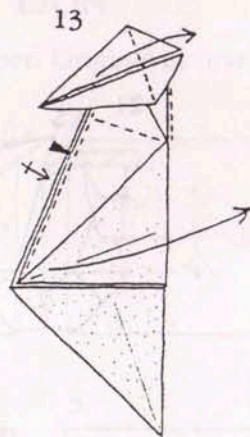

squash.

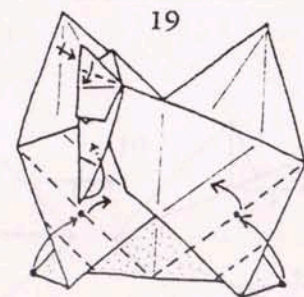
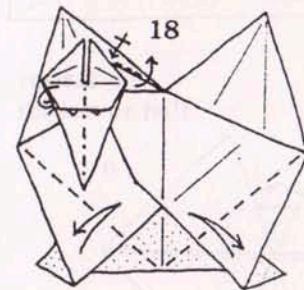
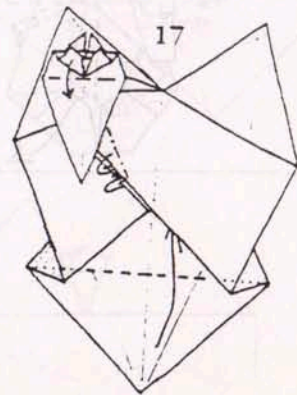

37

20

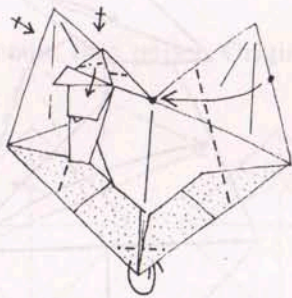

21

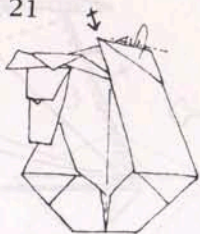

22

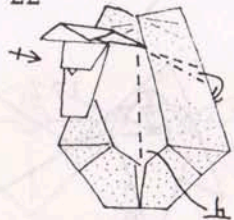

23

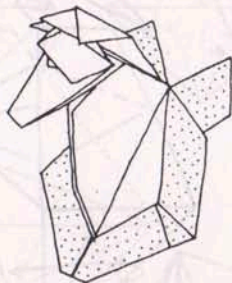

38

LION

Use thin paper. Original in orange.

1

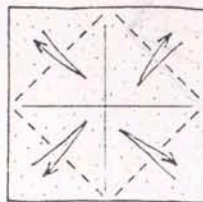

2

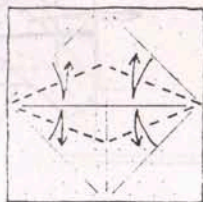

3

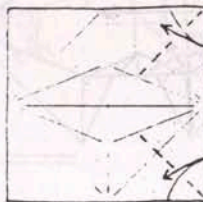

4

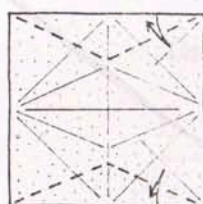

5

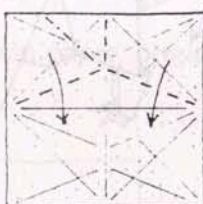

6

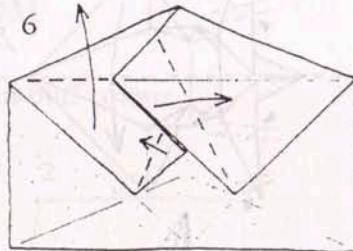

7

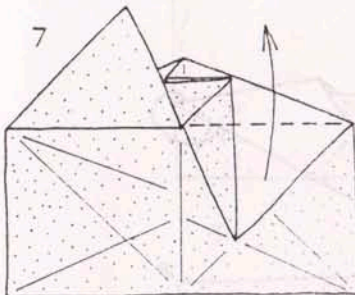

8

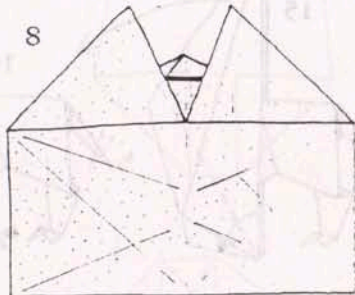

repeat 5-8
on lower half.

9

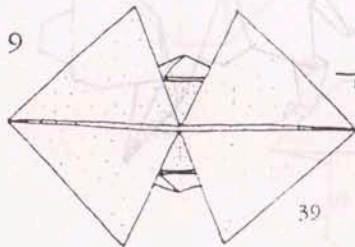

10

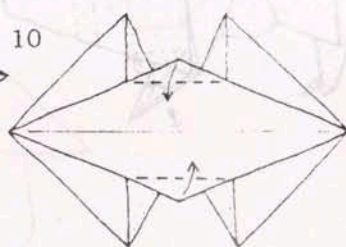

39

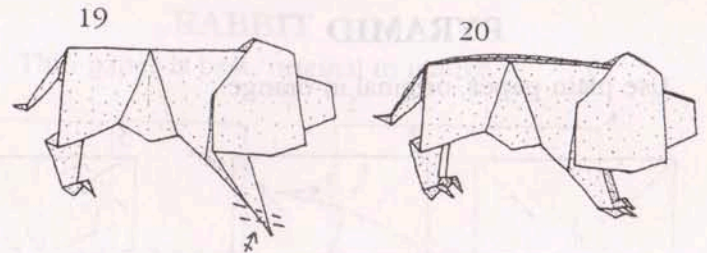
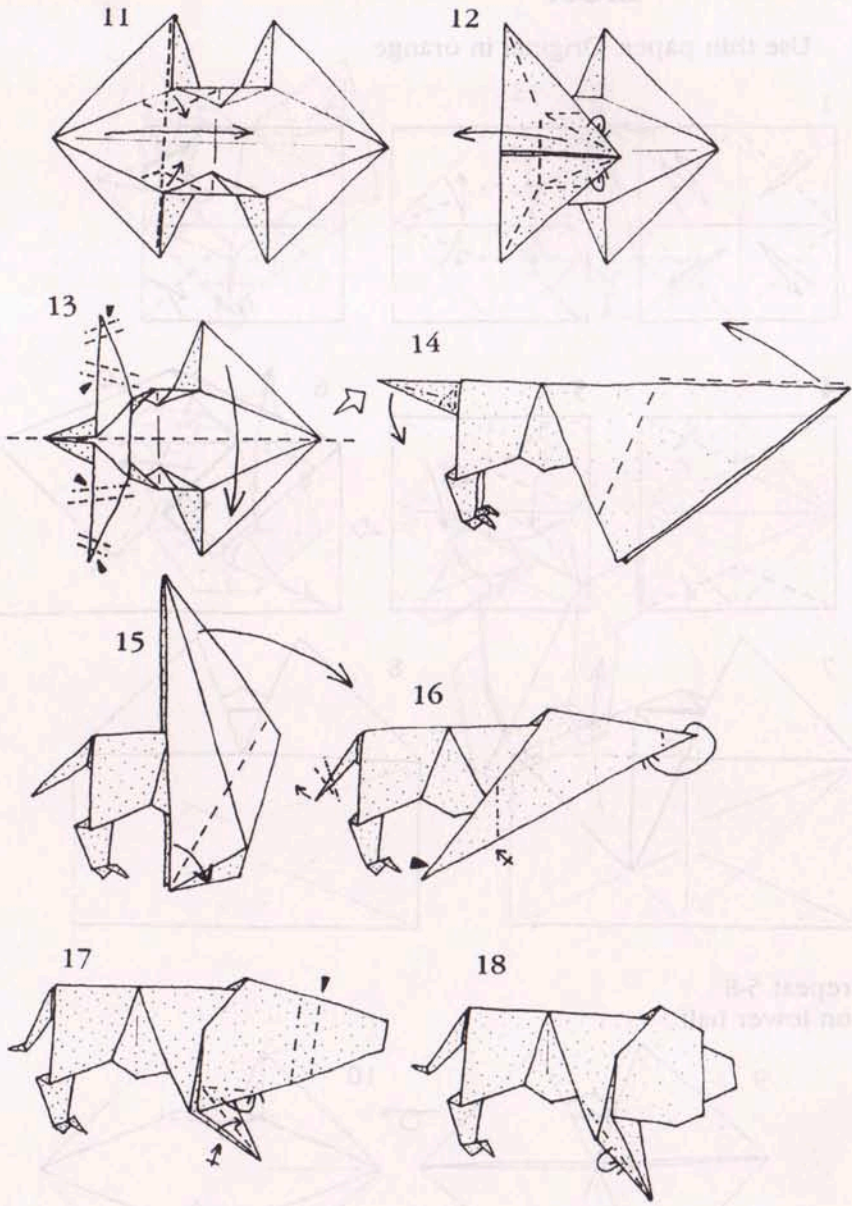

MUSHROOM

Use plain paper, original in buff colour.

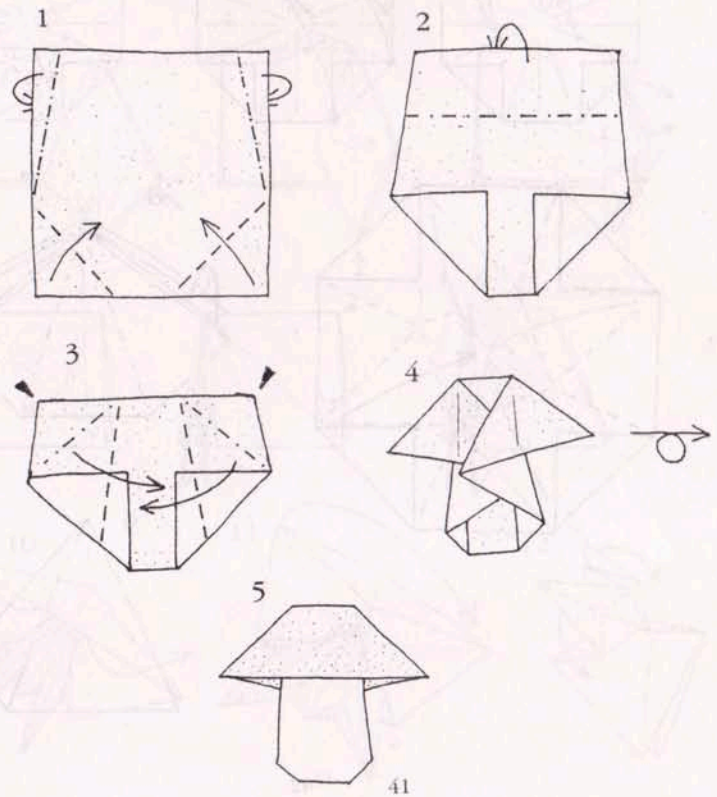

PYRAMID

Use plain paper, original in orange.

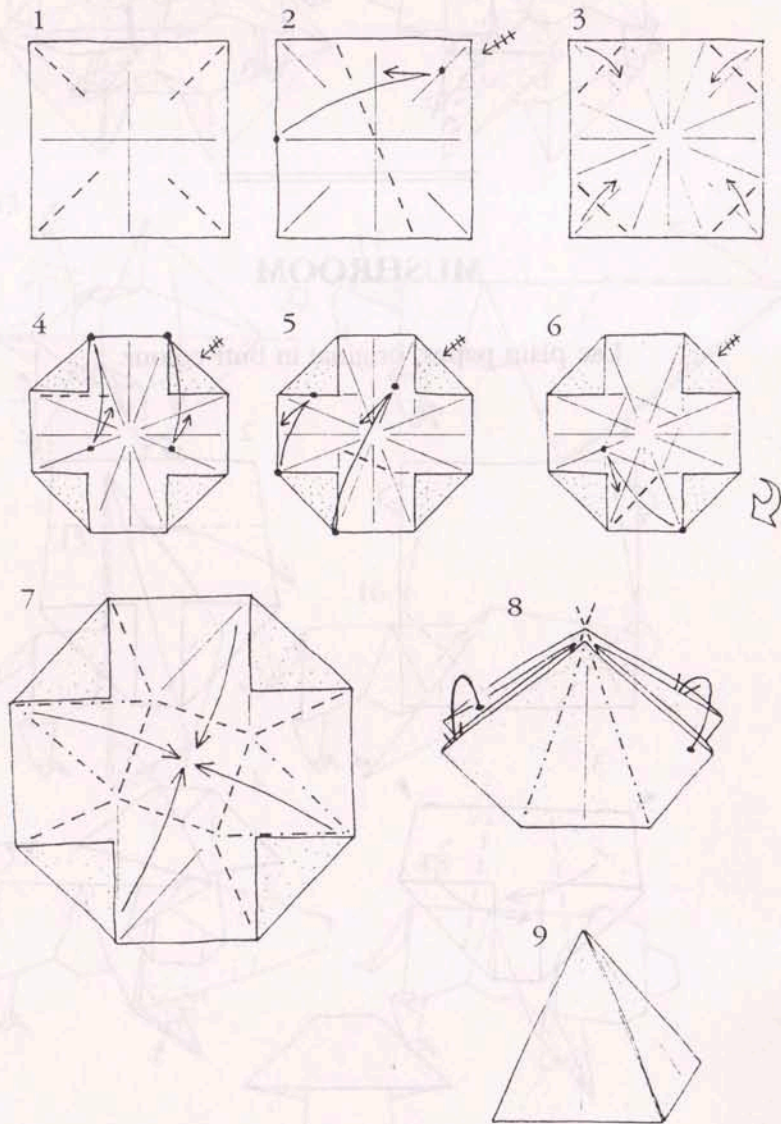

RABBIT

Thin paper is best, original in mauve.

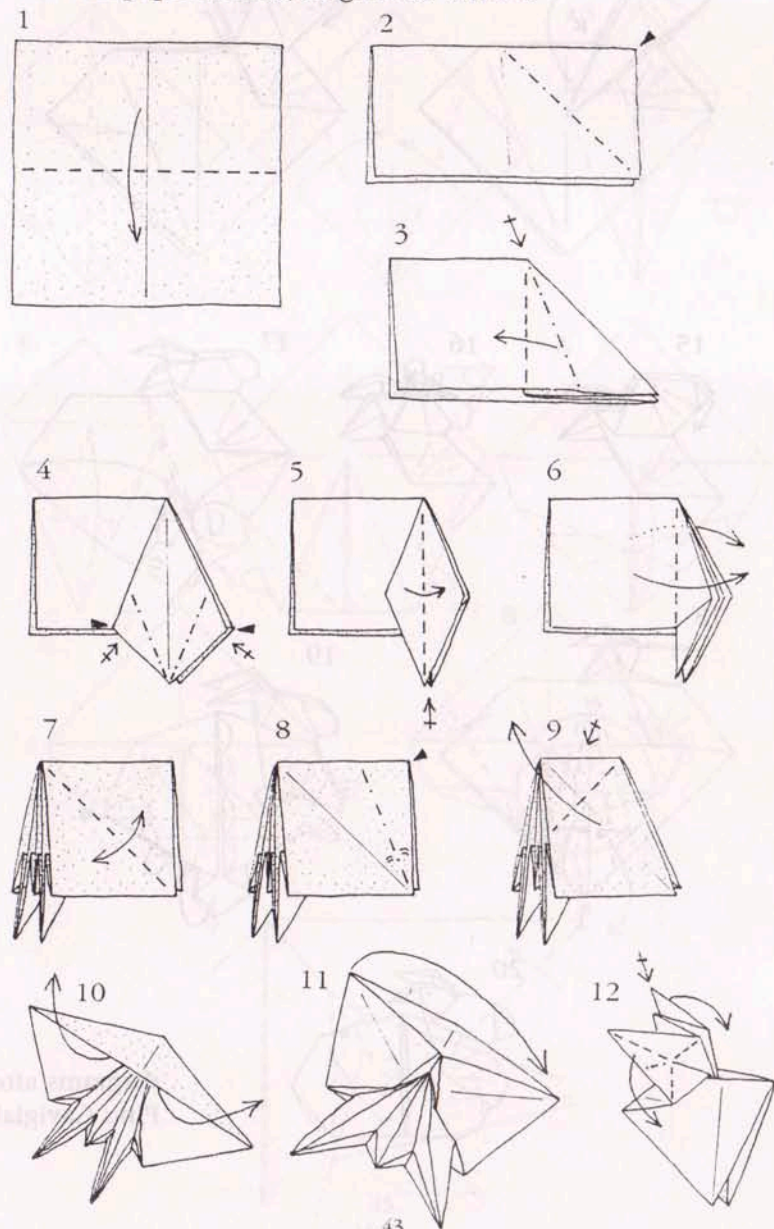

13

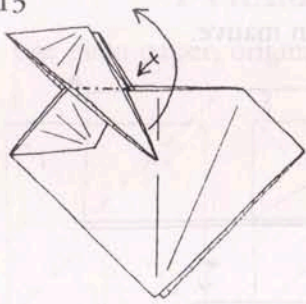

14

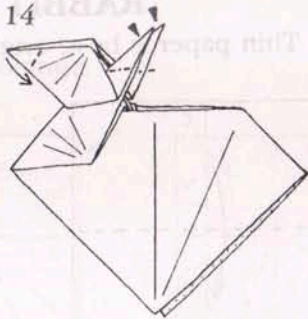

15



16



17

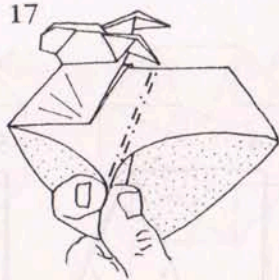

18

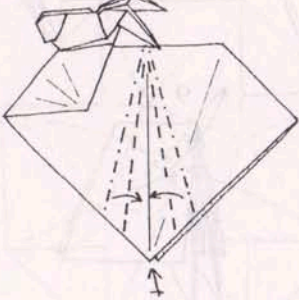

19

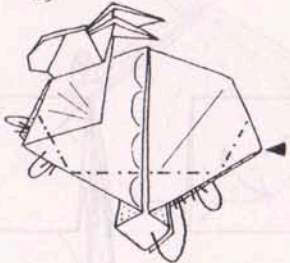

20



diagrams after
Pino Cavigliani

SAILBOARD

Use plain, thin, strong paper.

1

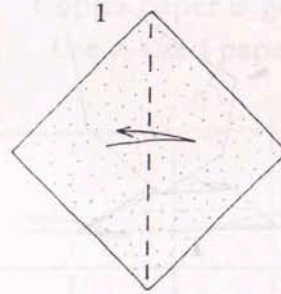

2

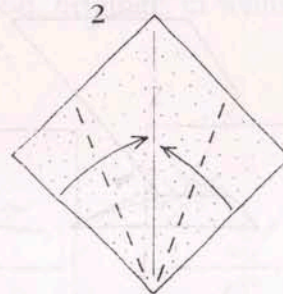

3

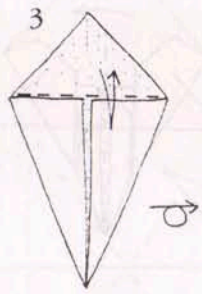

4

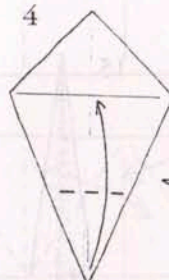

5

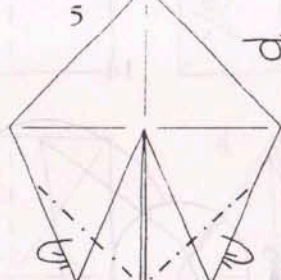

6

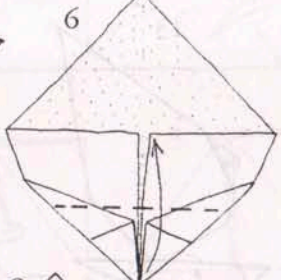

7

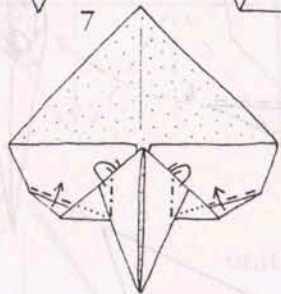

8

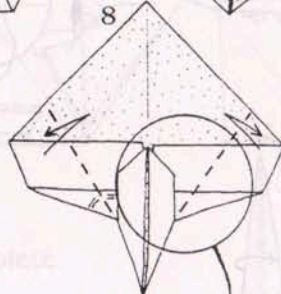

9

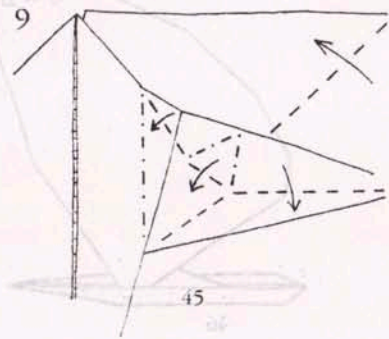

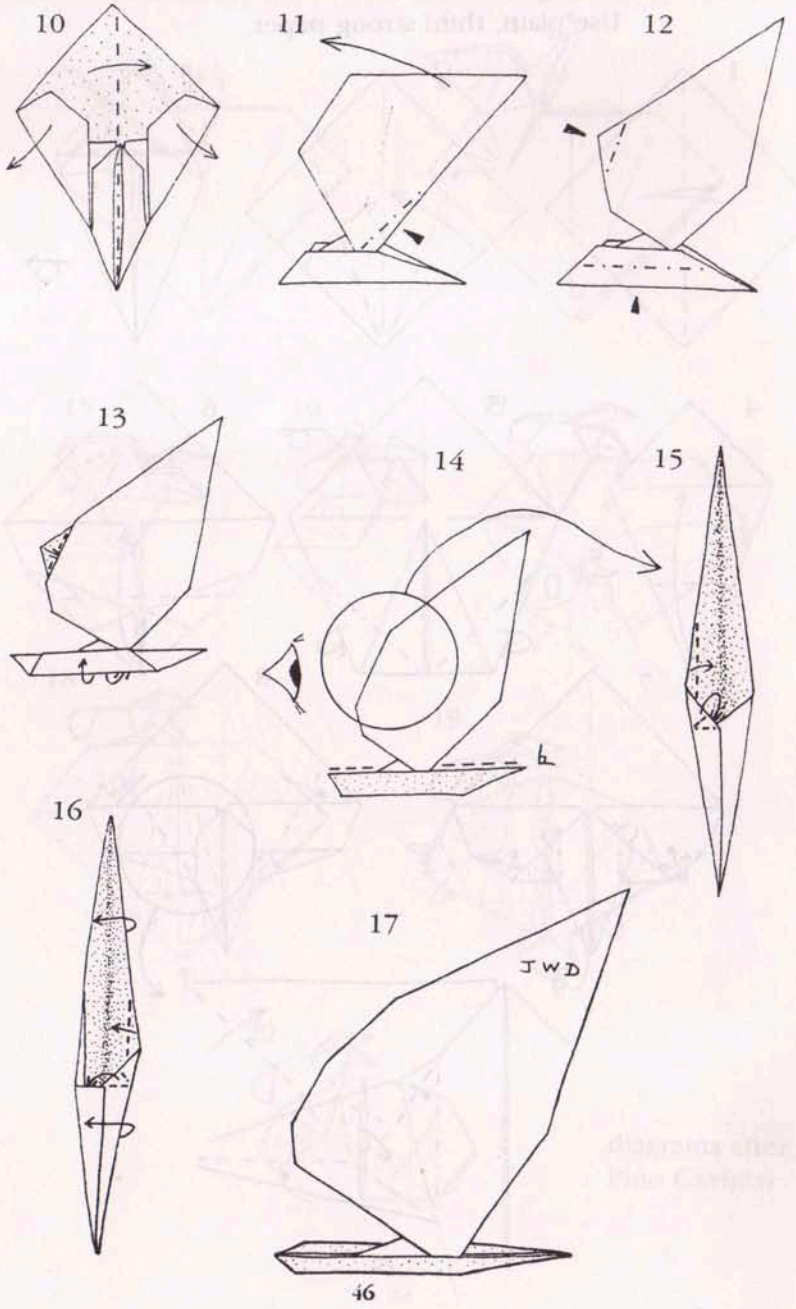

DIMPLED GEOMETRIC SOLIDS UNIT

Copier paper is good, originals in white.
Use A-sized paper.

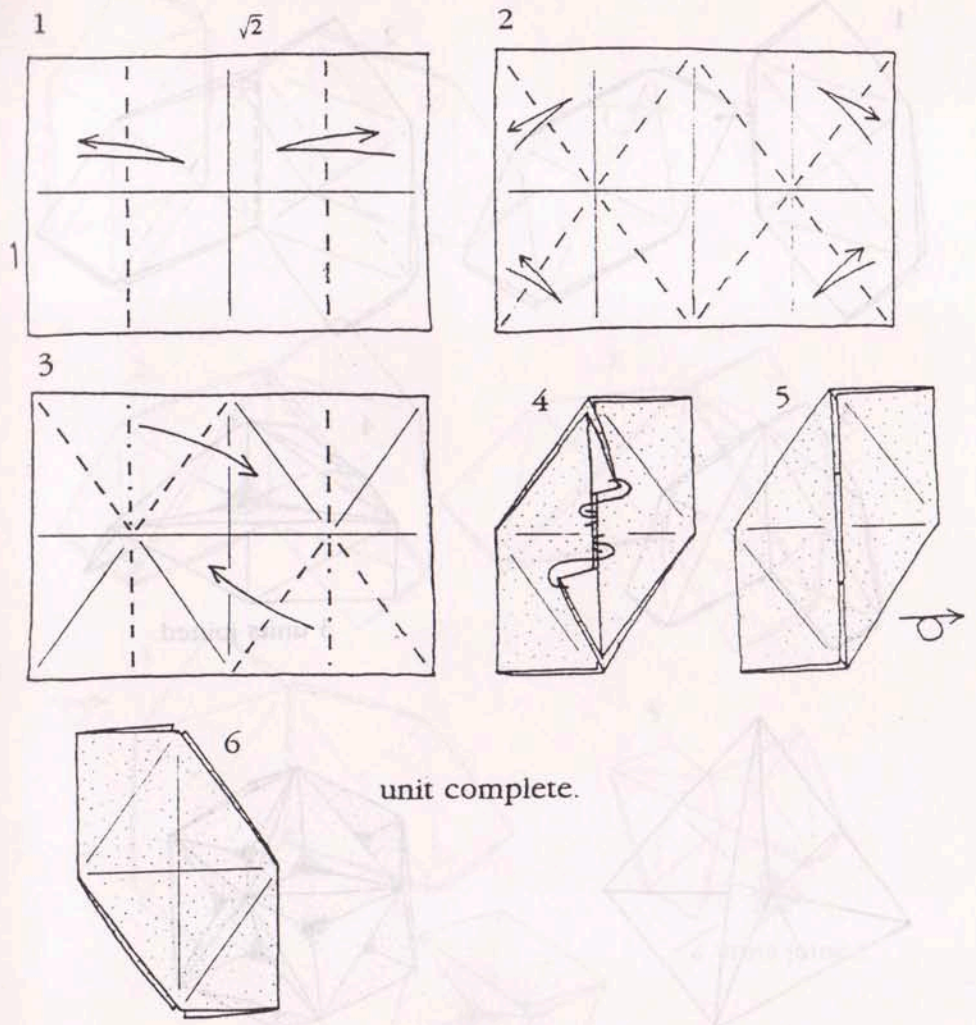

unit complete.

Assembly.

method 1.

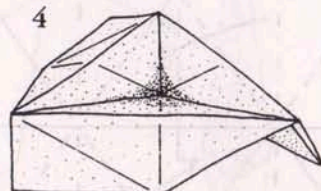
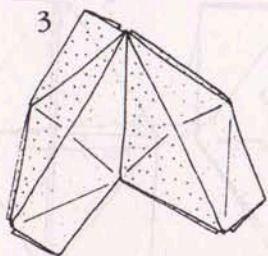
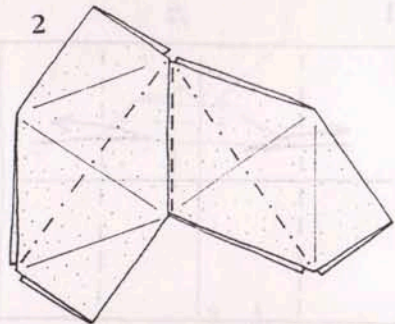
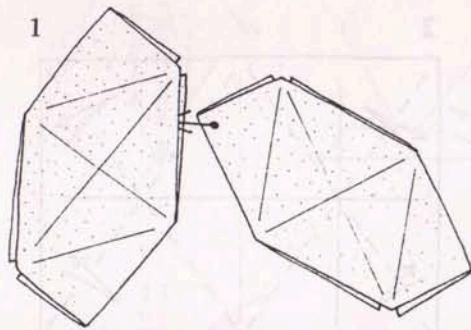

3 units joined.

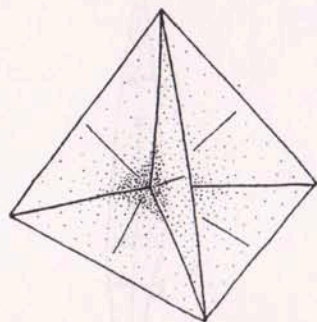

6 unit dimpled tetrahedron

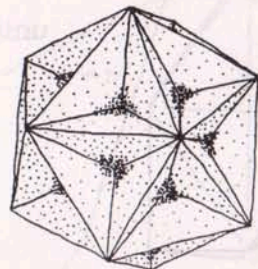

30 unit great dodecahedron.

method 2.

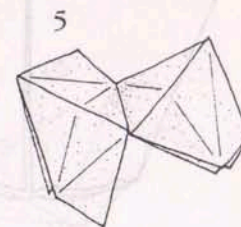
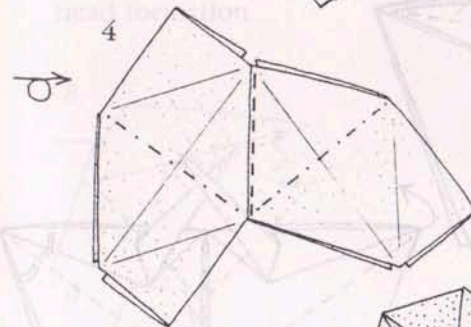
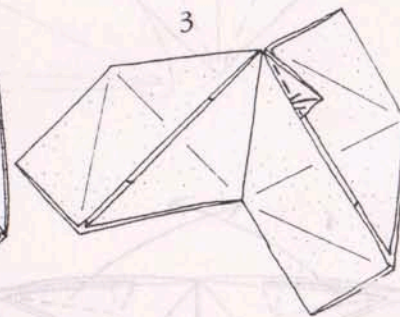
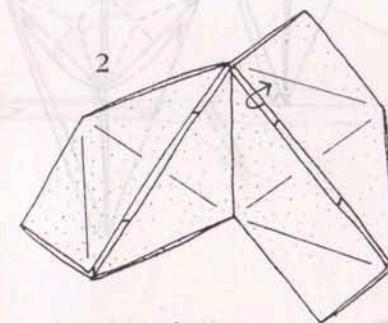
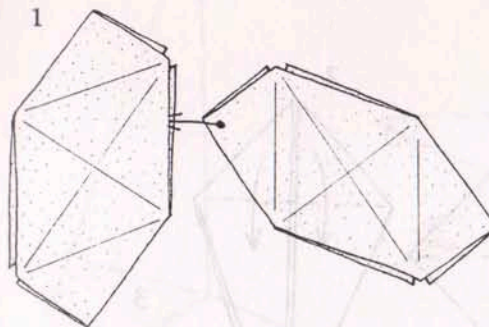

2 units joined.

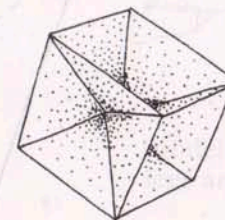

49 12 unit dimpled cube.

SPARROW

Use plain paper. Original in orange.

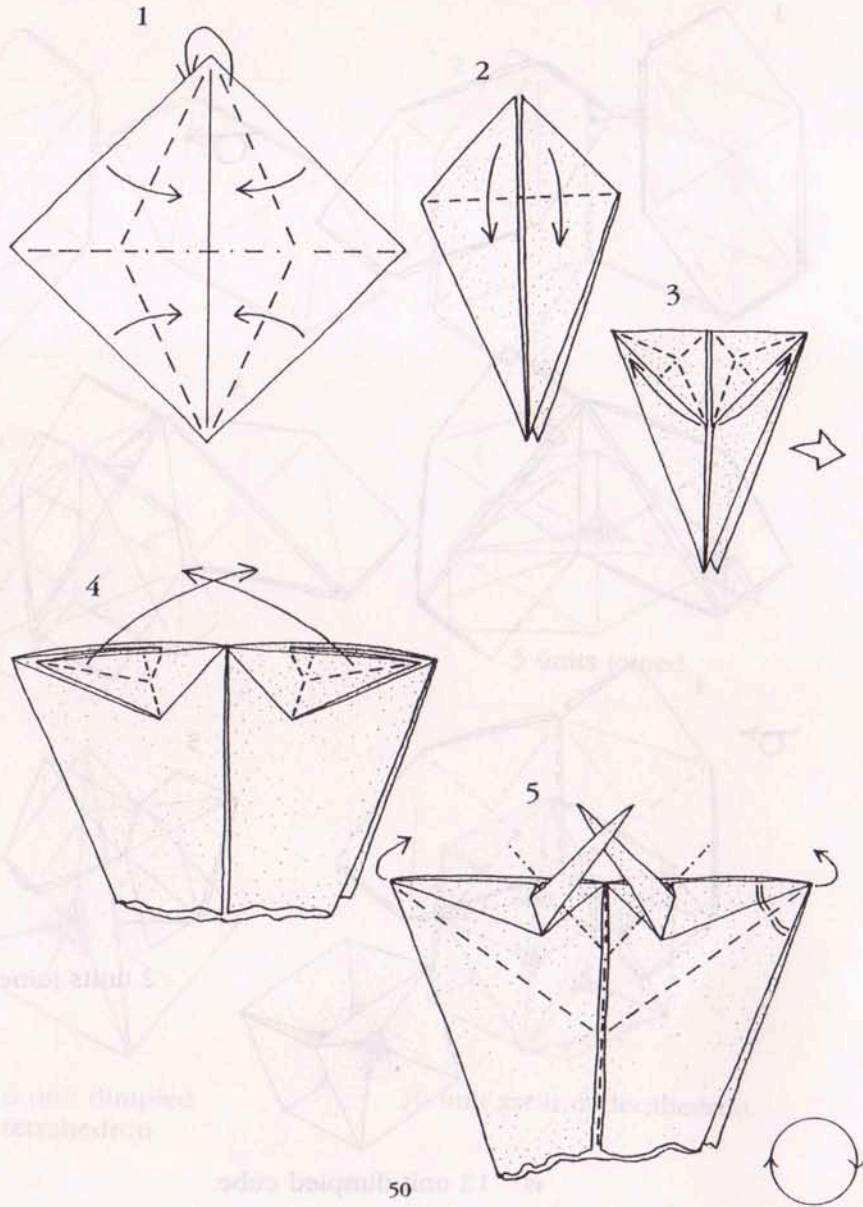

SPIDER

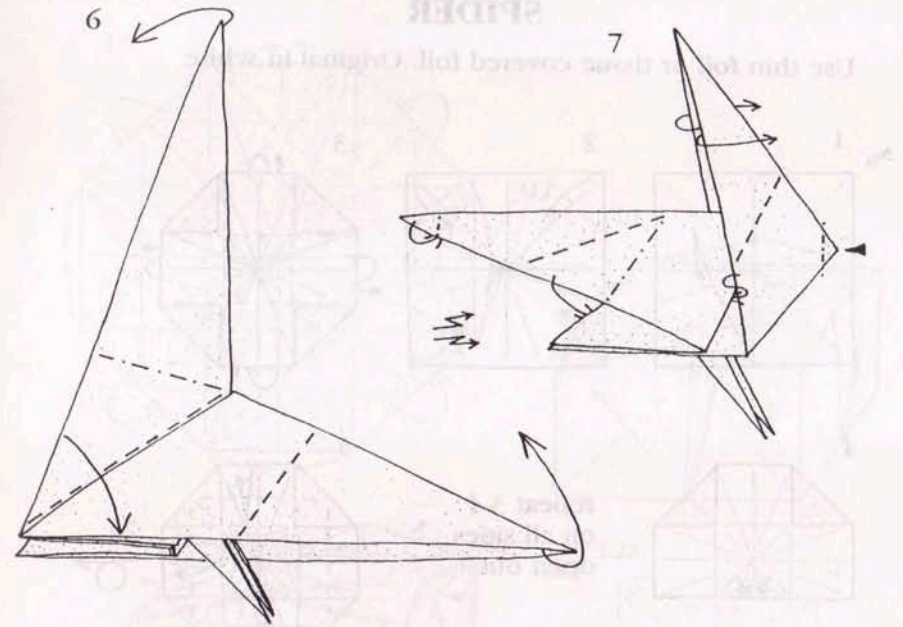

head formation.

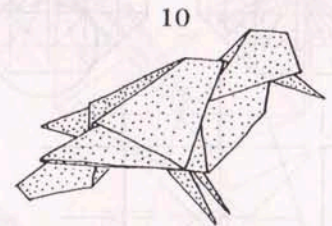
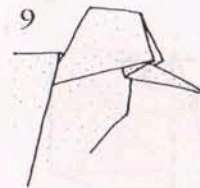
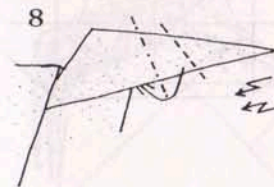

model stands on legs and tail.

SPIDER

Use thin foil or tissue covered foil. Original in white.

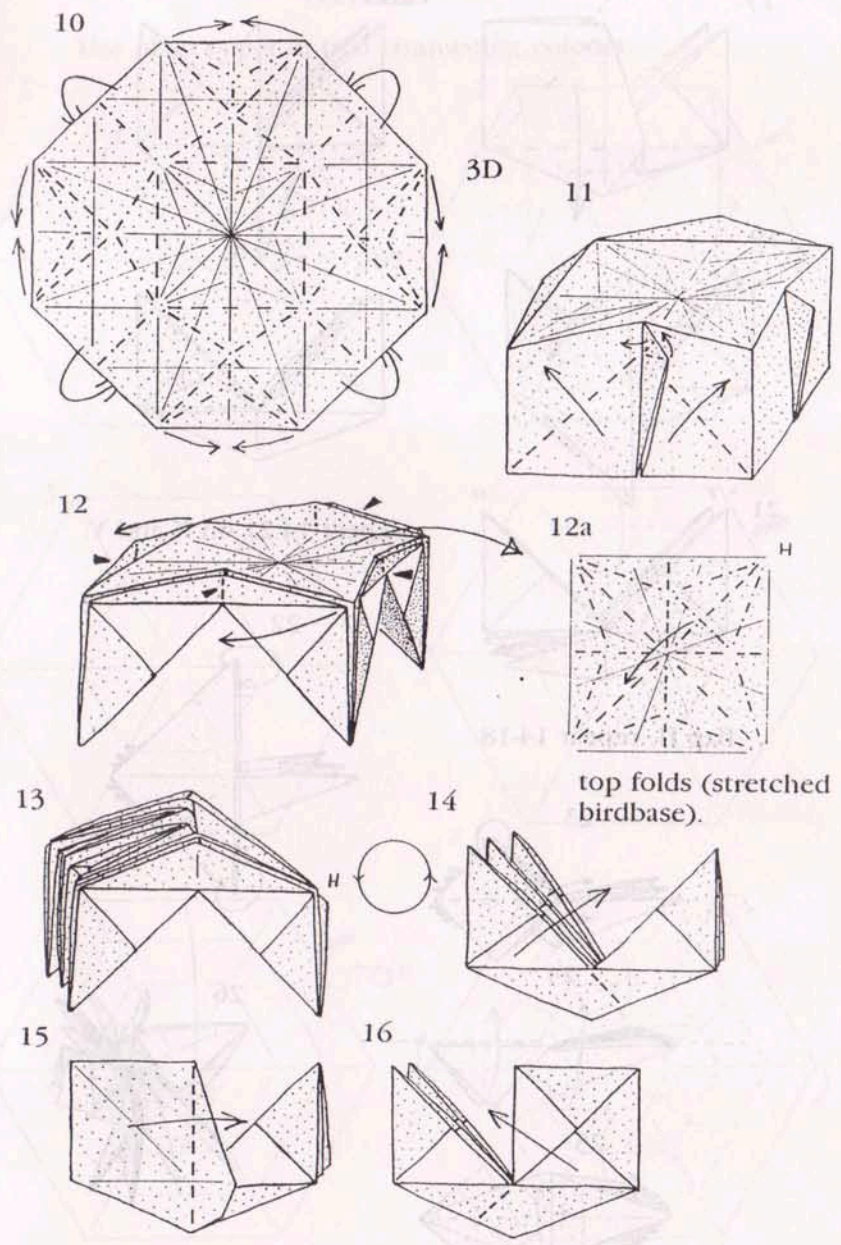
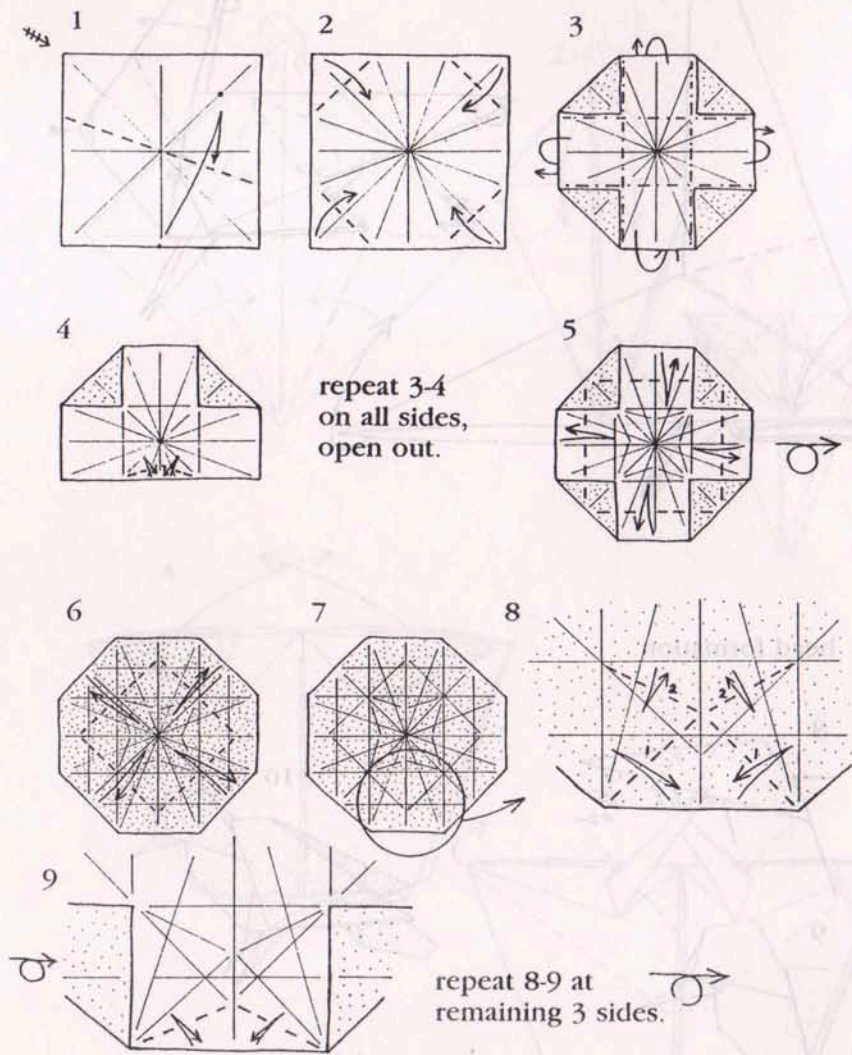

17

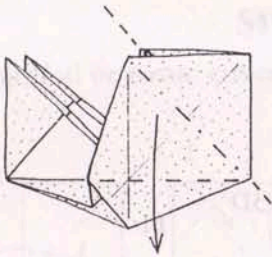

18

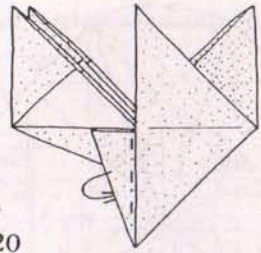

19

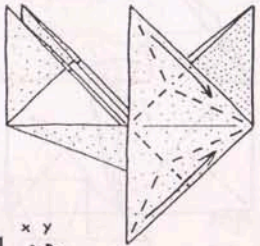

20

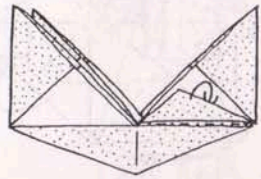

21

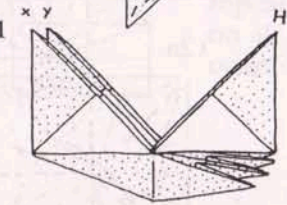

repeat 14-21 on X and Y.

22

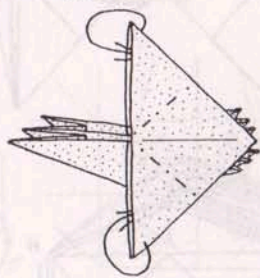

flap H, repeat 14-18.

23

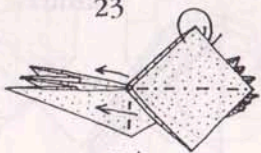

24

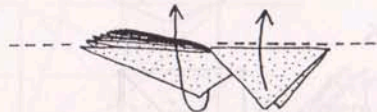

25

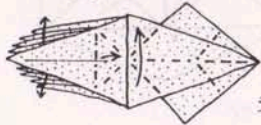

54

26



STAND

Use plain paper in two contrasting colours.

1

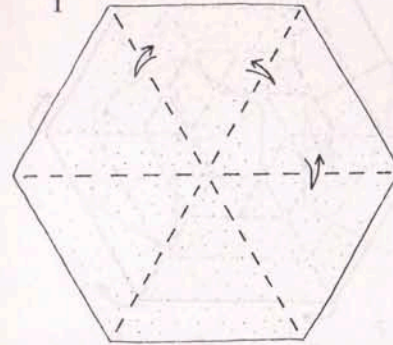

2

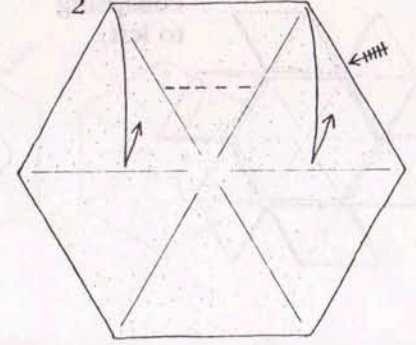

3

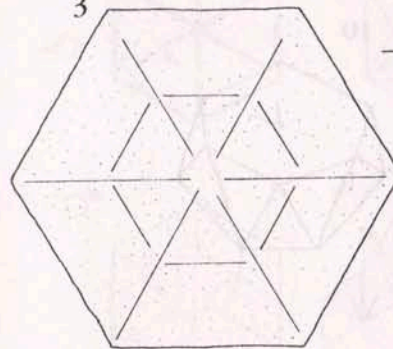

4

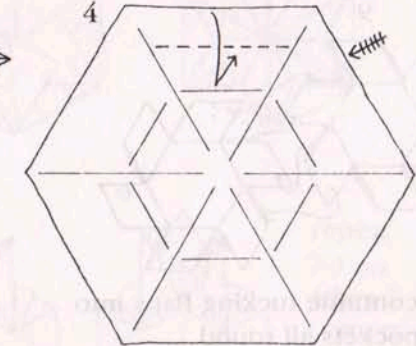

5

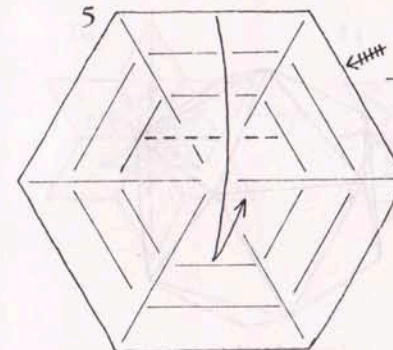

6

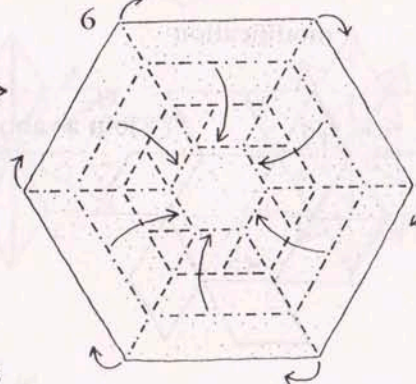

55

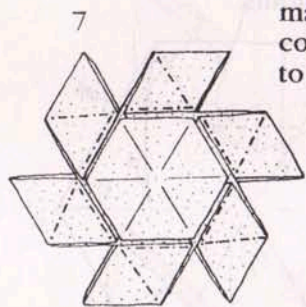

make another collapsing to left

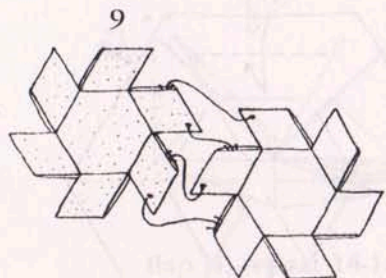
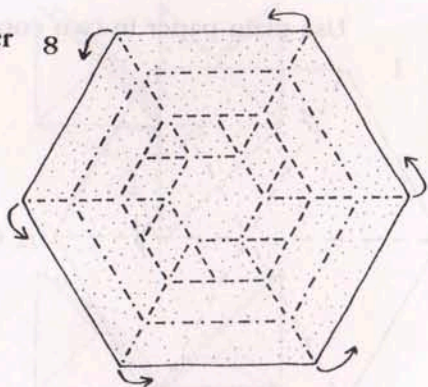

continue tucking flaps into pockets all round

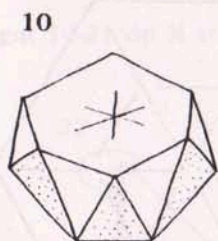

modification

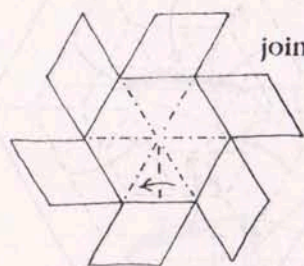

join as above

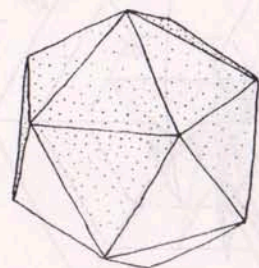

icosahedron

CHRISTMAS STAR

Use thin, plain paper.

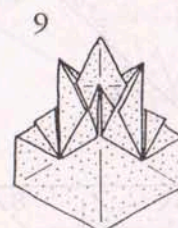
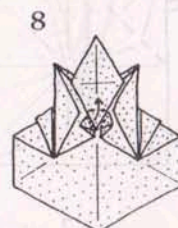
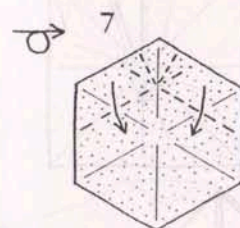
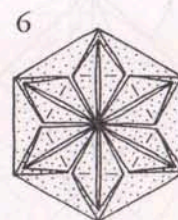
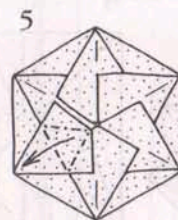
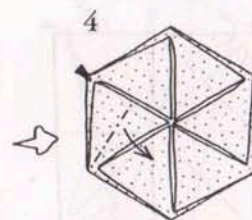
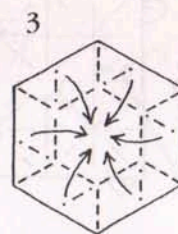
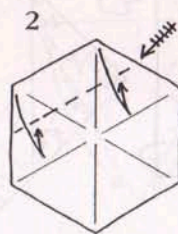
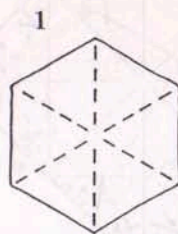

repeat 7-9 on other 5 corners.

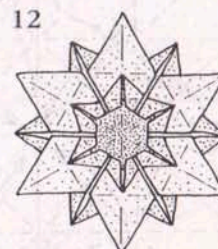
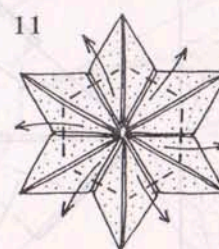
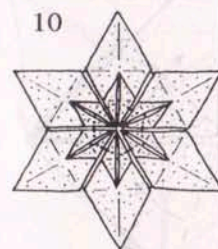

8 POINT STAR

Use thin paper. Original in squared harmony.

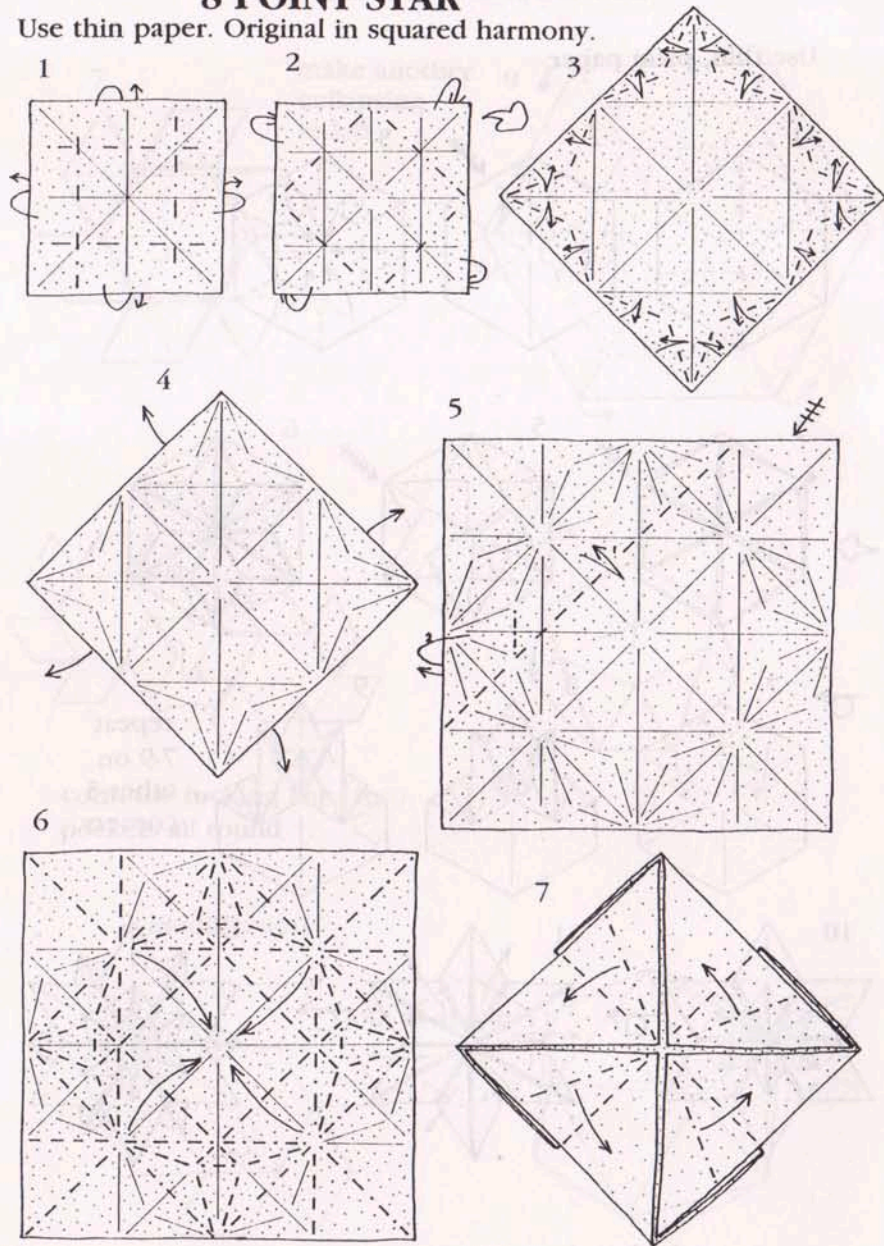

THREE COMPARTMENT TRAY

Use plain, slightly stiff paper.

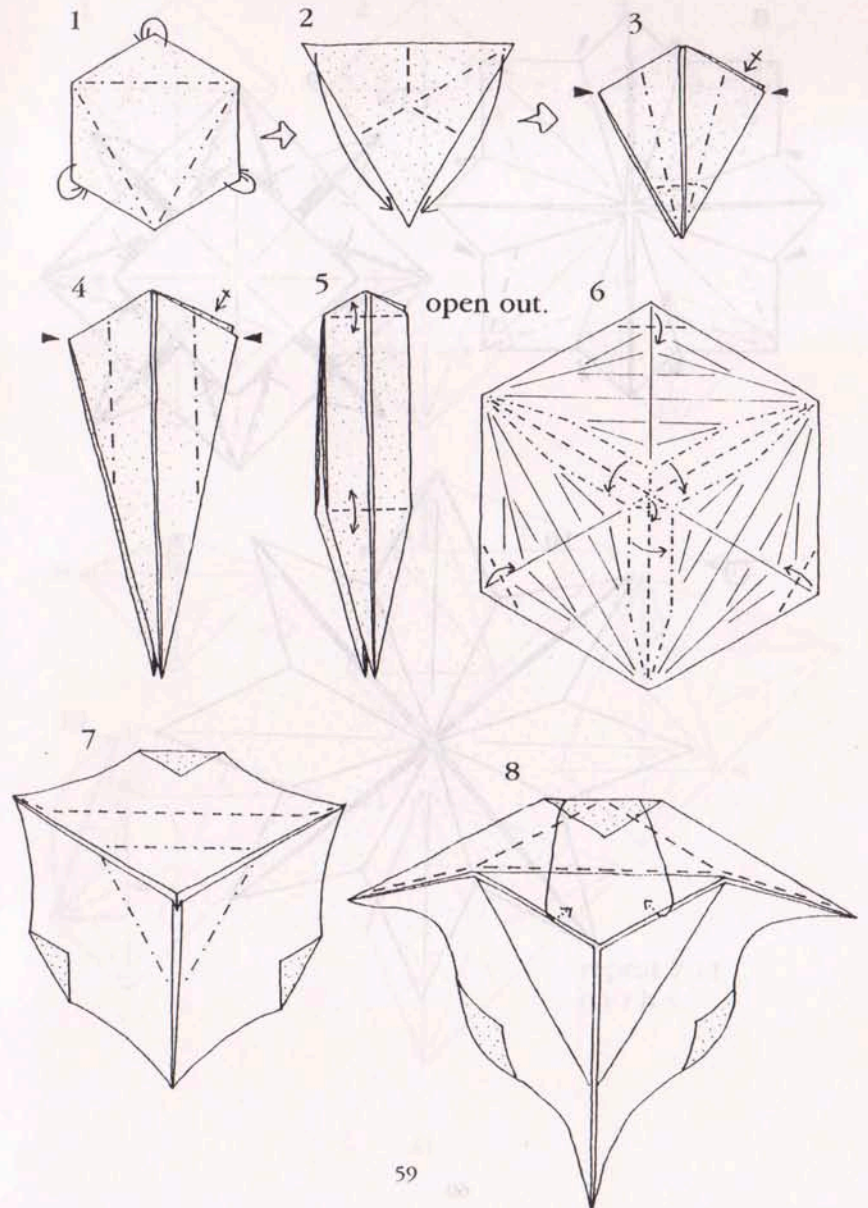

The paper should be stiff paper.

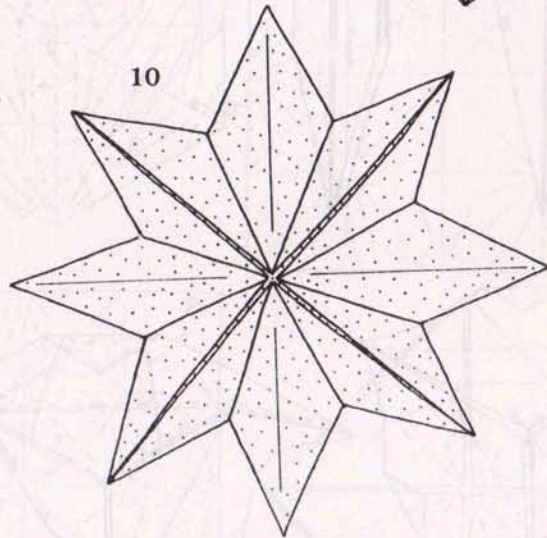
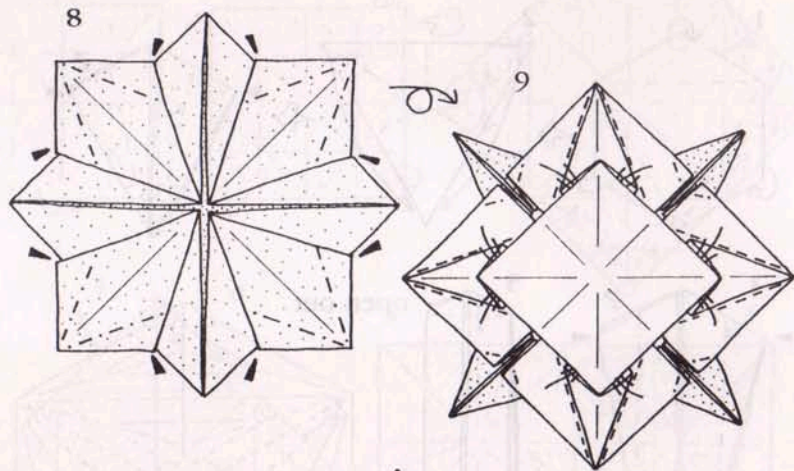

STAG HEAD TROPHY

Use plain thin paper. Original in brown.

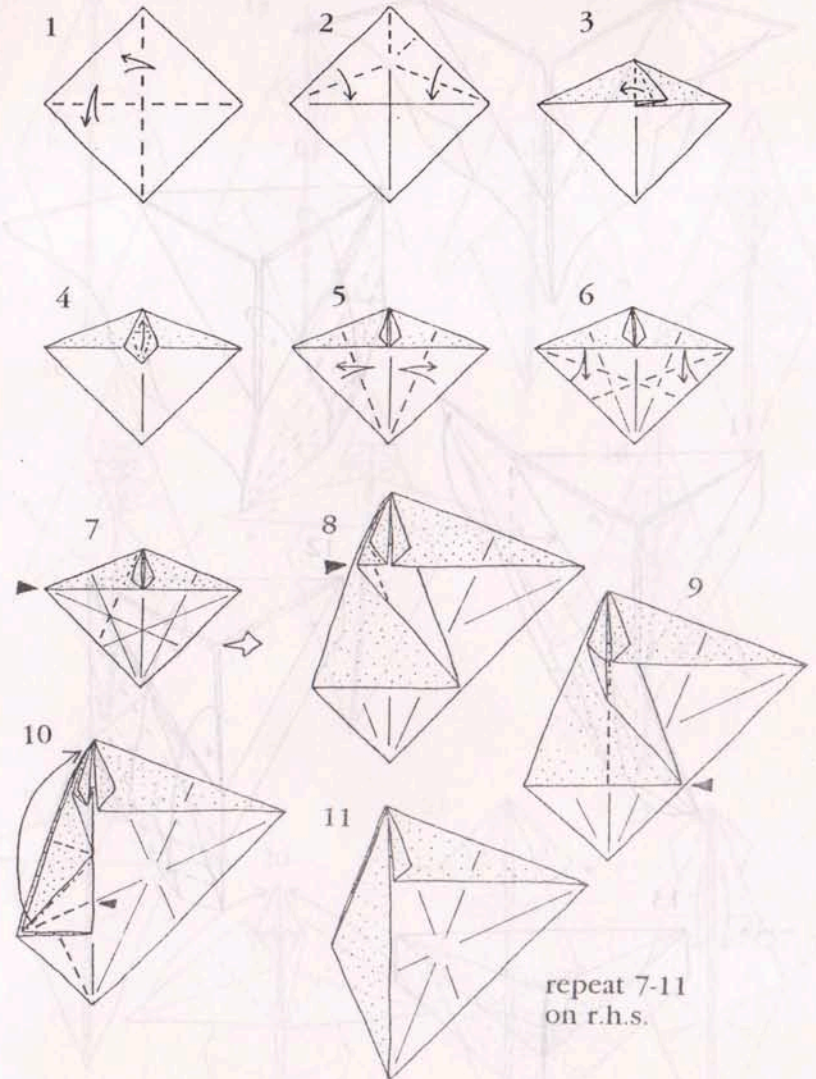

repeat 7-11 on r.h.s.

The plain thin paper. Original in brown

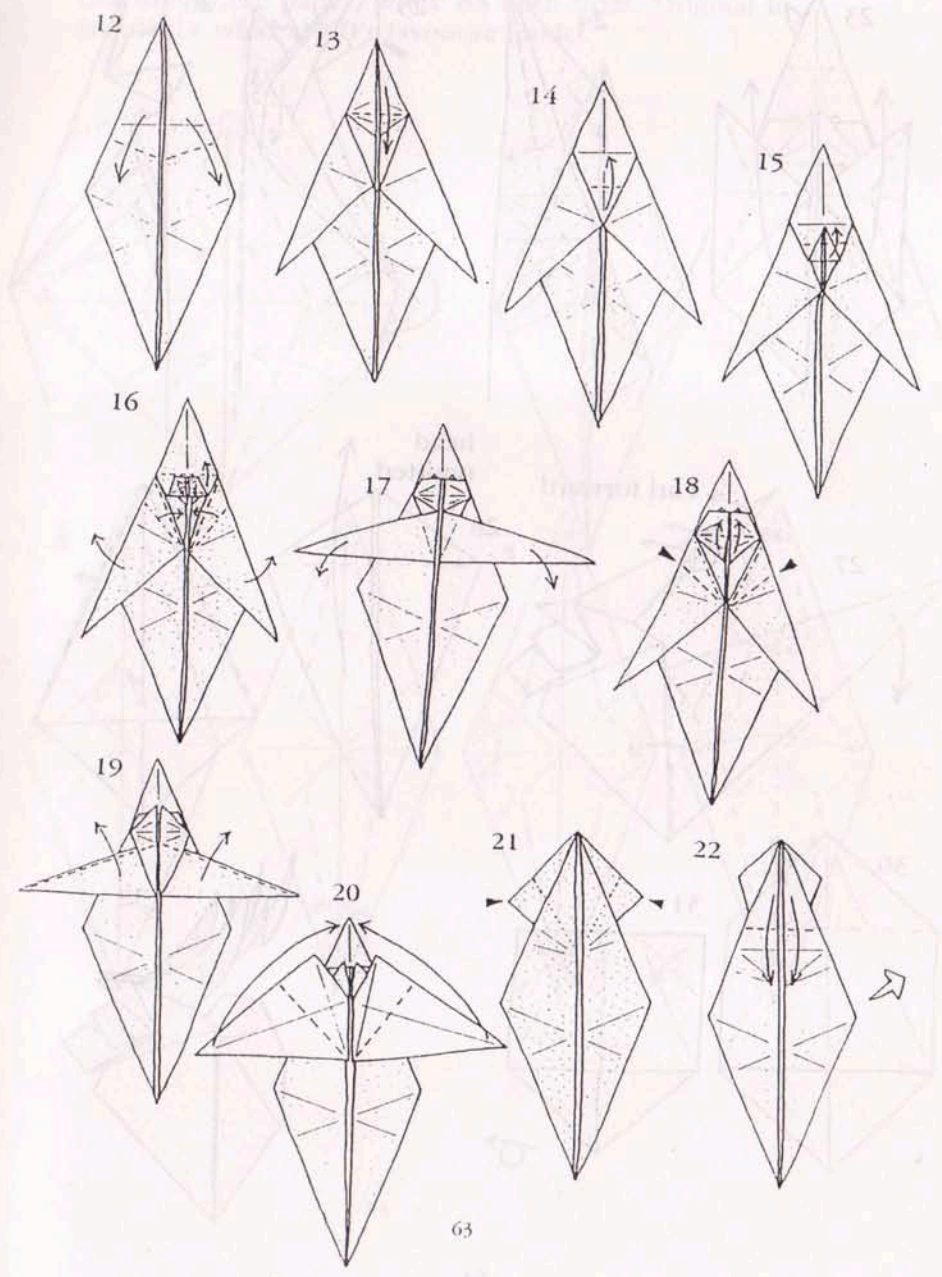
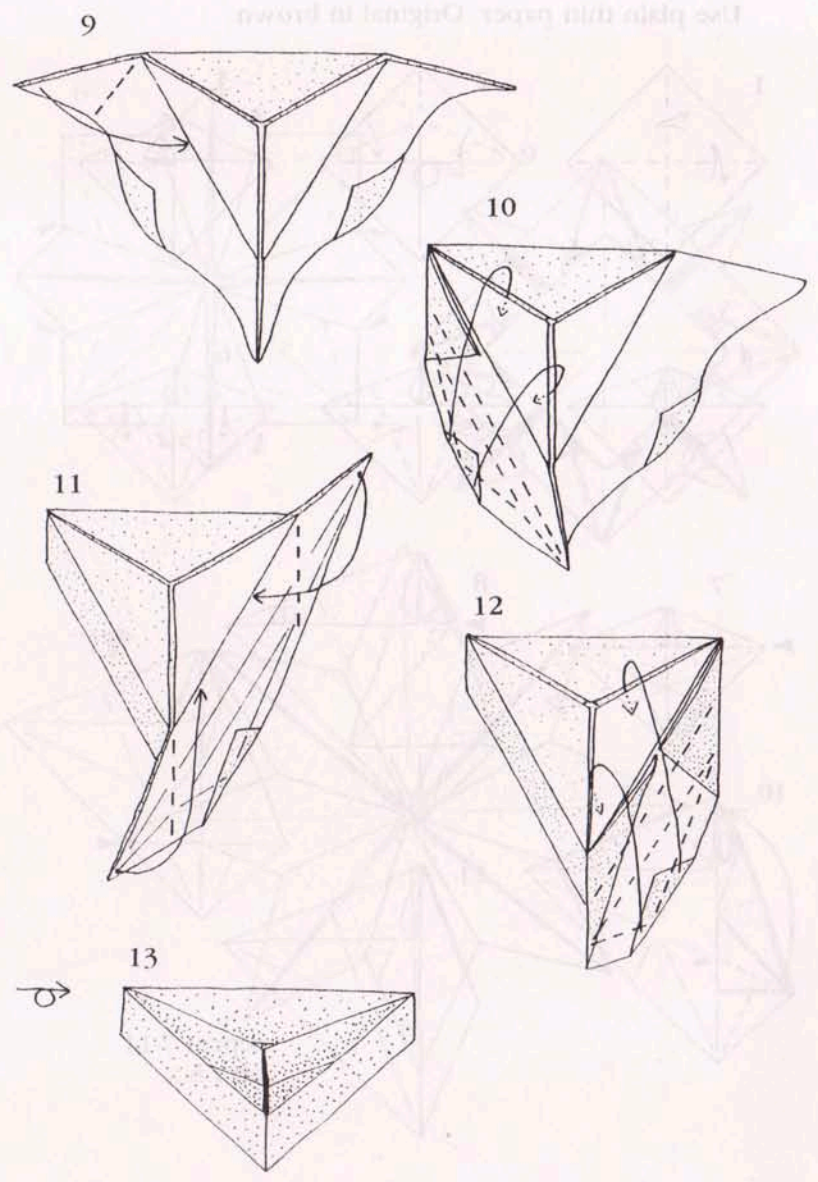

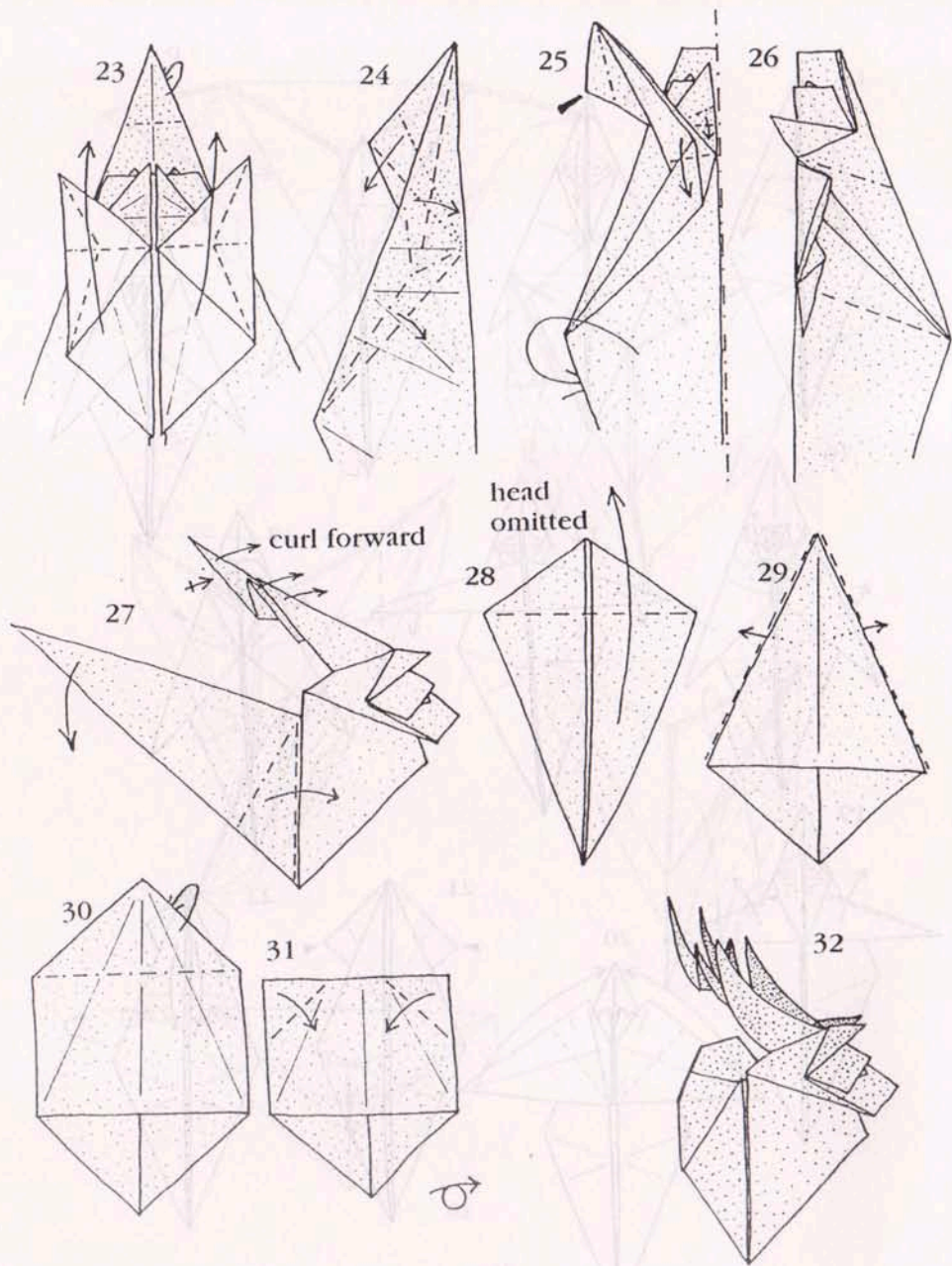

TWO SWANS

Use thin white paper, white on both sides. Original in Maxfield's white. JWD's favourite model.

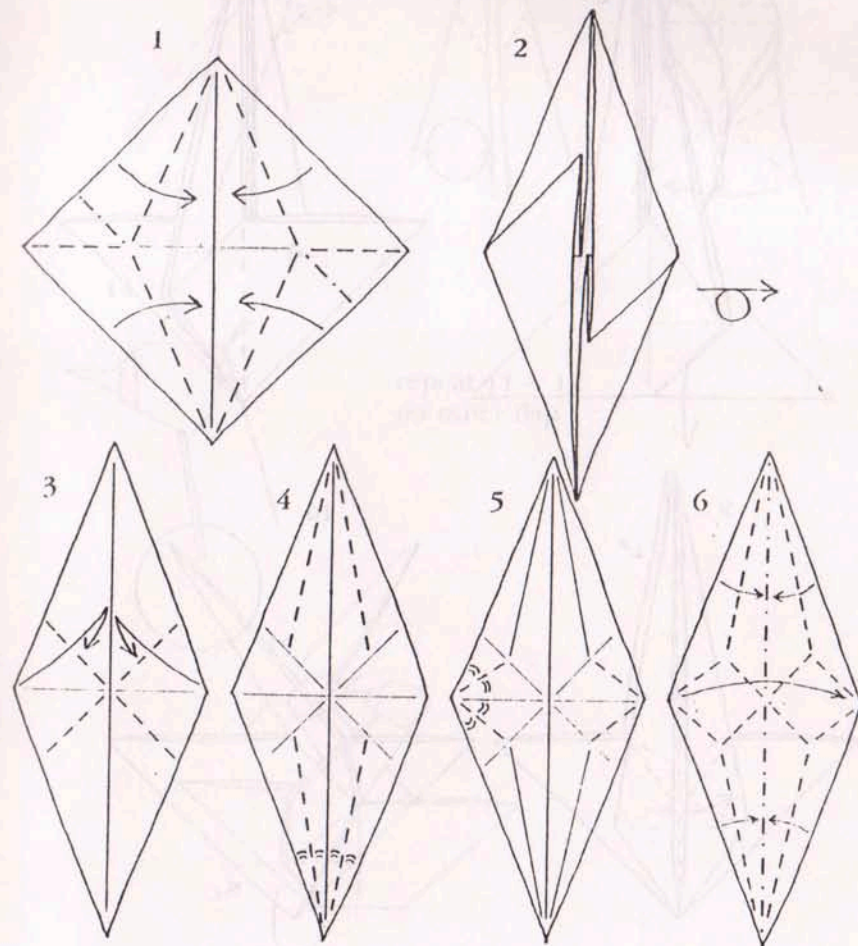

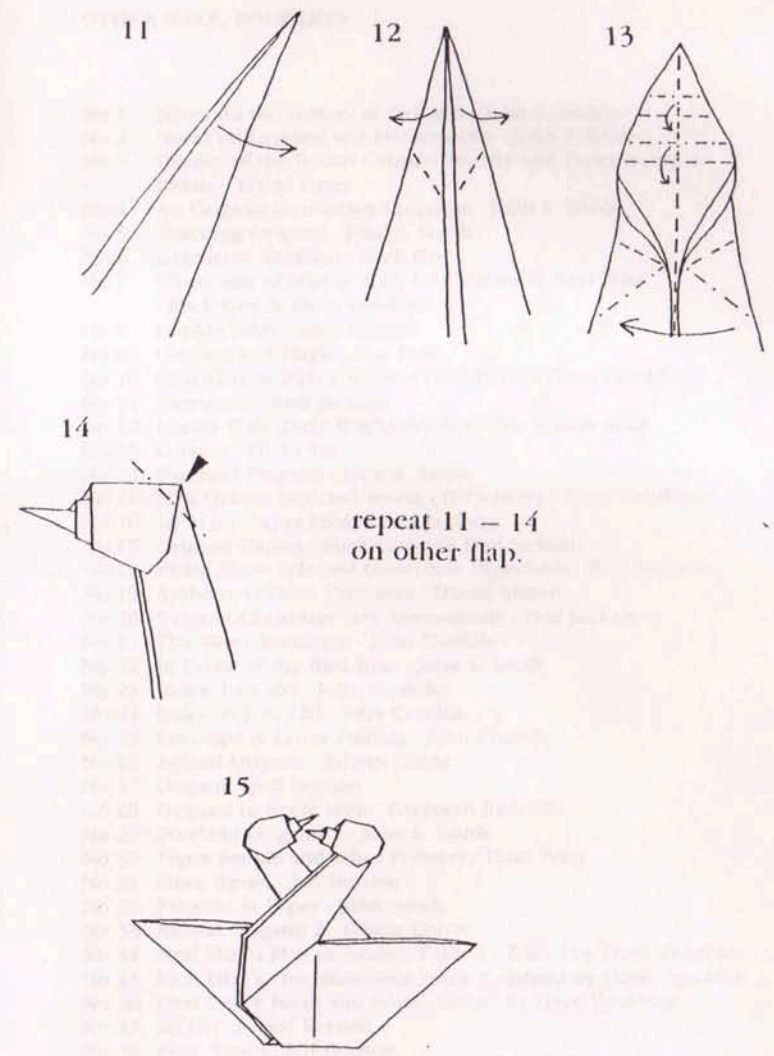
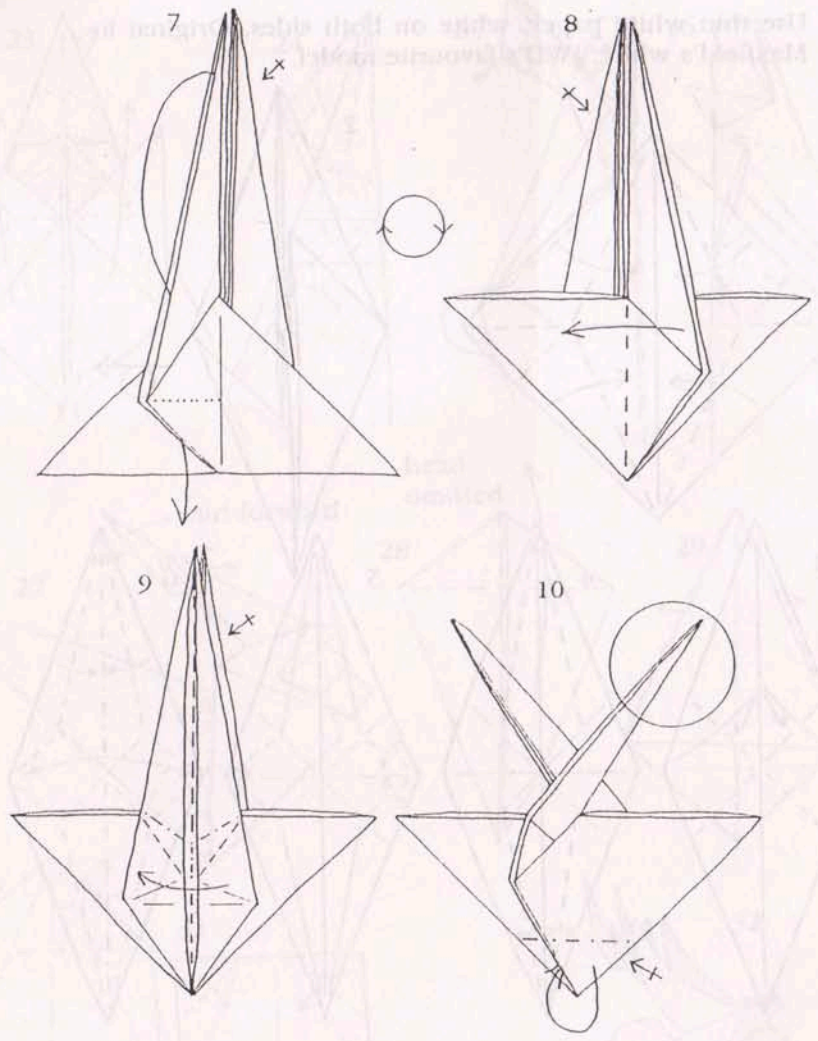

repeat 11 - 14
on other flap.

model stands
on base.

OTHER B.O.S. BOOKLETS

- No 1 Notes on the History of Origami - John S. Smith
- No 2 Notes on Origami and Mathematics - John S. Smith
- No 3 History of the British Origami Society and Paperfolding in Britain - David Lister
- No 4 An Origami Instruction Language - John S. Smith
- No 5 Teaching Origami - John S. Smith
- No 6 Geometric Division - Mick Guy
- No 7 Chess Sets of Martin Wall, Max Hulme & Neal Elias - Mick Guy & Dave Venables
- No 8 Napkin folds - John Cunliffe
- No 9 Origami and Magic - Ray Bolt
- No 10 Neal Elias: selected Works (1964-1973) - Dave Venables
- No 11 Flexagons - Paul Jackson
- No 12 Martin Wall: Early Works (1970-1979) - Martin Wall
- No 13 Orikata - Thoki Yenn
- No 14 Pureland Origami - John S. Smith
- No 15 Max Hulme: Selected works (1973-1979) - Dave Venables
- No 16 18 of my Paper Folds - Paul Jackson
- No 17 Origami Games - Mick Guy and Paul Jackson
- No 18 Philip Shen: Selected Geometric Paperfolds - Paul Jackson
- No 19 Anthony O'Hare: Creations - Daniel Mason
- No 20 Origami Christmas Tree Decorations - Paul Jackson
- No 21 The Silver Rectangle - John Cunliffe
- No 22 In Praise of the Bird Base - John S. Smith
- No 23 Index 1 to 100 - John Cunliffe
- No 24 Index 101 to 120 - John Cunliffe
- No 25 Envelope & Letter Folding - John Cunliffe
- No 26 Animal Origami - Edwin Corrie
- No 27 Origami - Jeff Beynon
- No 28 Origami to begin with - Gwyneth Radcliffe
- No 29 Pureland Origami 2 - John S. Smith
- No 30 Paper people and other Pointers - Dave Petty
- No 31 More 'Igami - Jeff Beynon
- No 32 Patterns in Paper - John Smith
- No 33 Animal Origami 2 - Edwin Corrie
- No 34 Neal Elias's Miscellaneous Folds 1 - Edited by Dave Venables
- No 35 Neal Elias's Miscellaneous Folds 2 - Edited by Dave Venables
- No 36 Neal Elias's Faces and Busts - Edited by Dave Venables
- No 37 Jef Ori' 3 - Jeff Beynon
- No 38 Four 'Igami - Jeff Beynon
- No 39 Animal Origami 3 - Edwin Corrie
- No 40 The Genius of Jan Willem Derksen - D Petty
- No 41 Convention Packs Index 1979 - 1991 - D Petty
- No 99 10 Simple Paper Folds: Origami for Beginners - Paul Jackson

199 1 Notes on the History of Origami - John E. Smith
 199 2 Notes on Origami and Mathematics - John E. Smith
 199 3 History of the British Origami Society and Publications in Britain - David Lacey
 199 4 An Origami Invention Language - John E. Smith
 199 5 Teaching Origami - John E. Smith
 199 6 Geometric Division - Mark Day
 199 7 Great Sets of Models with Mark Day's & John E. Smith's - Mark Day & John E. Smith
 199 8 Origami with - John E. Smith
 199 9 Origami and Magic - John E. Smith
 199 10 New Line Selected Works (1964-1977) - John E. Smith
 199 11 Origami - John E. Smith
 199 12 Japan With Origami (1972-1977) - John E. Smith
 199 13 Origami - John E. Smith
 199 14 Teaching Origami - John E. Smith
 199 15 The Index Selected Works (1977-1979) - David Lacey
 199 16 It's Not Just Paper - David Lacey
 199 17 Origami Games - Mark Day and John E. Smith
 199 18 Origami - Between Scientific Experiments - David Lacey
 199 19 Origami - David Lacey
 199 20 Origami - Between John E. Smith and David Lacey
 199 21 The Origami Dictionary - John E. Smith
 199 22 In Praise of the First Book - John E. Smith
 199 23 Index 1 to 199 - John E. Smith
 199 24 Index 101 to 199 - John E. Smith
 199 25 Lapsley & Lacey Folding - John E. Smith
 199 26 Animal Origami - John E. Smith
 199 27 Origami - John E. Smith
 199 28 Origami to Light with - David Lacey
 199 29 Origami - John E. Smith
 199 30 Paper Models and other things - David Lacey
 199 31 Origami - John E. Smith
 199 32 Origami in Paper - John E. Smith
 199 33 Origami - John E. Smith
 199 34 Origami - John E. Smith

All Publications available from B.O.S. Supplies Officers
 Lyn & David Mitchell, 22 Blae Tarn Road, Kendal, Cumbria, LA9 7NA.

FOR FURTHER INFORMATION ABOUT ORIGAMI WRITE TO
 General Secretary - Peter Ford, 11 Yarningdale Road, Kings Heath,
 Birmingham, B14 6LT.

or
 Membership Secretary - Mrs Penny Groom, 2a The Chestnuts,
 Countesthorpe, Leicester, LE8 3TL.