

József Zsebe

FOLD LINE

hajtásvonal



József Zsebe

FOLD LINE
hajtásvonal



2012

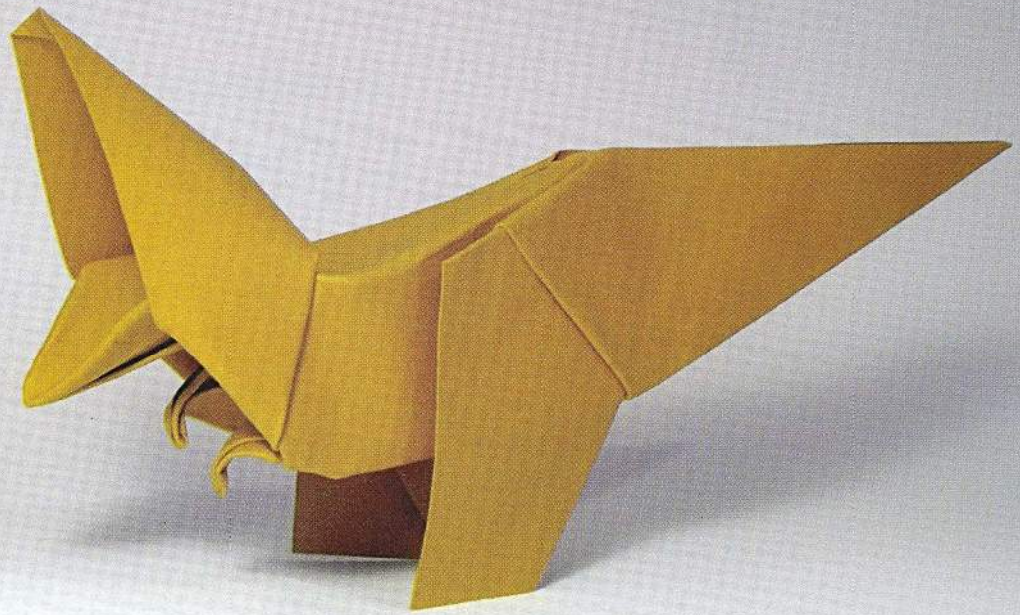



Introduction

Dear Reader,

This publication was compiled after a long pause to provide you with 10 new models, some of which require a unique, three-dimensional folding technique. The animals in this book have been a popular subject for many origami creators, however, I hope that you will find new and interesting solutions in my approach .

The models have been diagrammed using fewer steps than what is customary, but this should not deceive you. Most of the models can be completed with the enthusiasm of beginners, the persistence of advanced folders and the experience of professionals, to match the models shown on the photos. Of course, you will find in this publication some models that can be folded from traditional origami paper, but the rest will require either special paper or folding technique to achieve a good result. For these reasons, I would recommend this publication for the more experienced origamists.

These creations were modelled based on images from my memory, therefore some of them resemble the subject realistically, while others are somewhat exaggerated. However, my goal was not working out of perfect details, but to focus on characters, shapes ideas, and paper usage.

I hope you will enjoy folding and I wish you many successful projects.

József Zsebe
Kölesd, 09 August 2012

Előszó

Kedves Olvasó,

Hosszú idő után állítottam össze ezt a kötetet, melyben – az előző kiadványok folytatásaként – 10 új modellem szerepel. Ezek között több háromdimenziós, speciális technikát igénylő figura van. Az itt található állatokat természetesen sokan, sokféleképpen meghajtogatták már, de ebben a könyvben talán mégis fellelhető néhány különleges ötlet, megoldás.

A modelleket viszonylag kevés fázisban rajzoltam le, de ez ne tévessze meg Önöket. Az alkotások nagy részét a kezdők lendületével, a haladók kitartásával és a profik tapasztalatával lehet elkészíteni úgy, ahogy a képeken láthatóak. Természetesen van ebben a könyvben olyan modell, ami hagyományos origami papírból is elkészíthető, de egy-két hajtogatás csak az általam ajánlott papírból készíthető el sikeresen. Ezt a kiadványt így elsősorban a már gyakorlattal rendelkező hajtogatóknak ajánlom.

Az alkotásokat emlékezetemből mintáztam, így némelyik szinte valóság-hű, de van olyan is, amelyik csak vonalaiban idézi fel az eredetit, egyes részei eltúlzottak. Ebből következik, hogy nem a részletek kidolgozása volt a cél, inkább a karakter, a forma, az ötlet, a papírkihasználtság kapott nagyobb hangsúlyt.

Minden kedves origami iránt érdeklődőnek sikeres hajtogatást kívánok!

Zsebe József
Kölesd, 2012. augusztus 09.

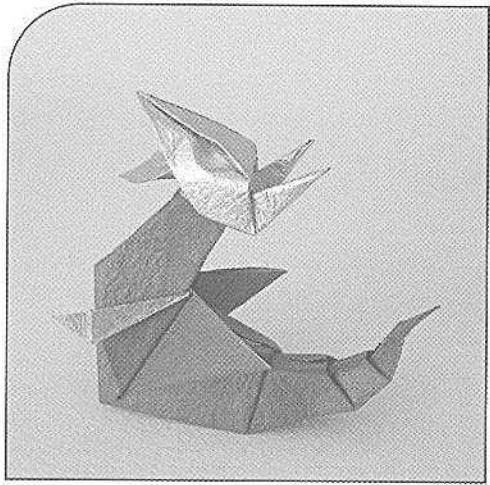

The little dragon

Kis sárkány (2010)

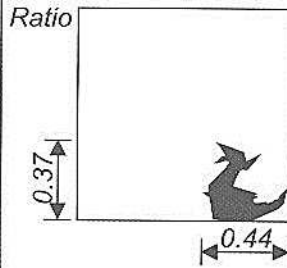

Suggested technique or paper:

- Traditional origami paper
- Tissue foil (Best option)
- Wet-fold

Paper color: Any bicolour.

Suggested paper size: 30 cm.

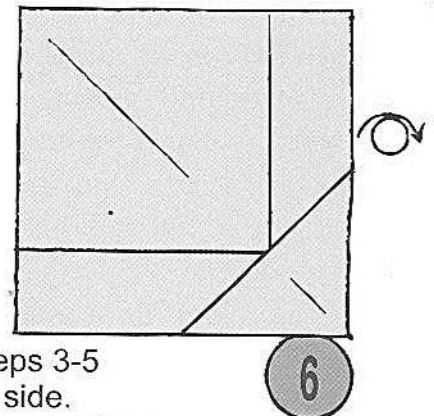
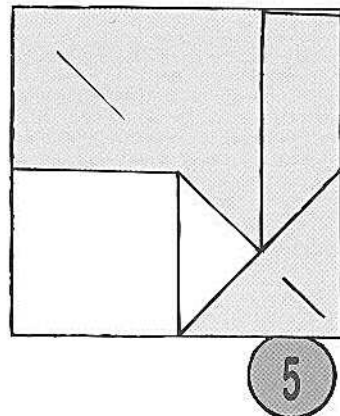
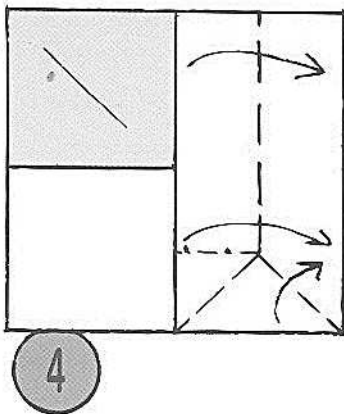
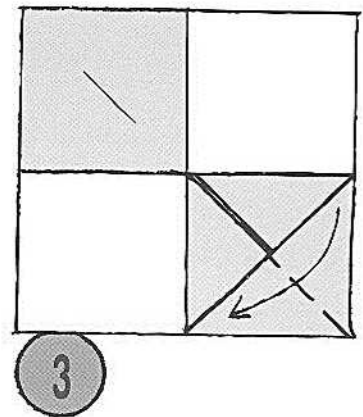
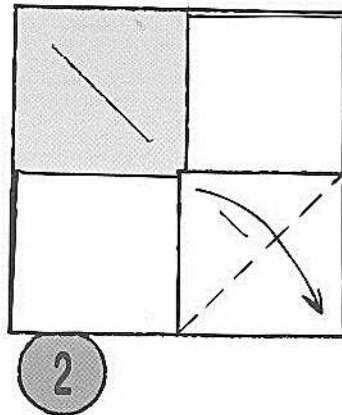
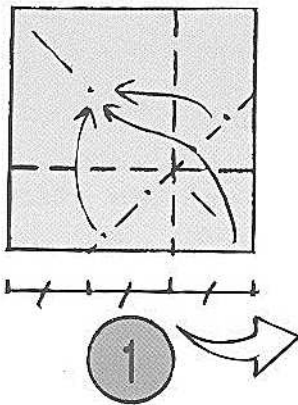

Repeat steps 3-5 on the left side.

Ismételd meg a 3-as lépéstől a hajtásokat a bal oldalon!

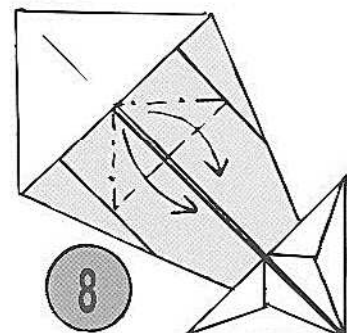
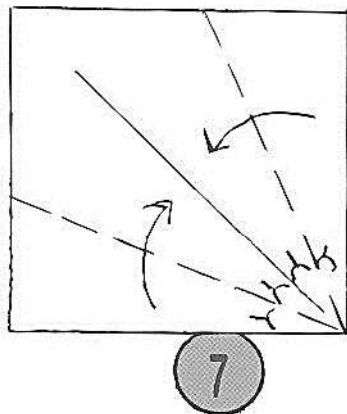

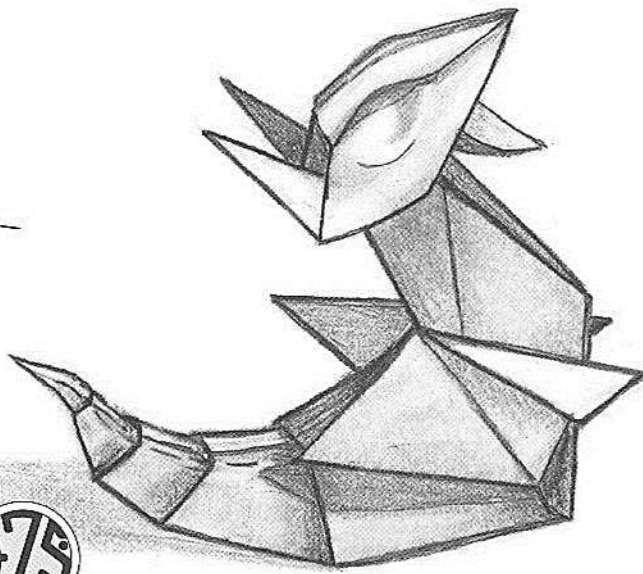
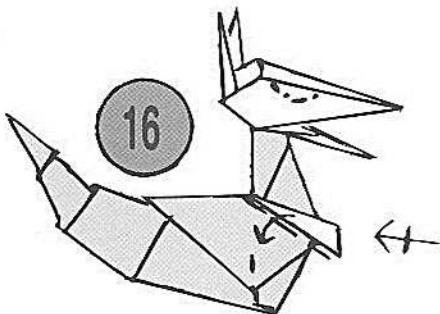
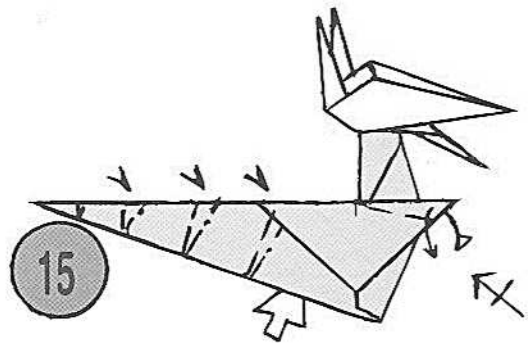
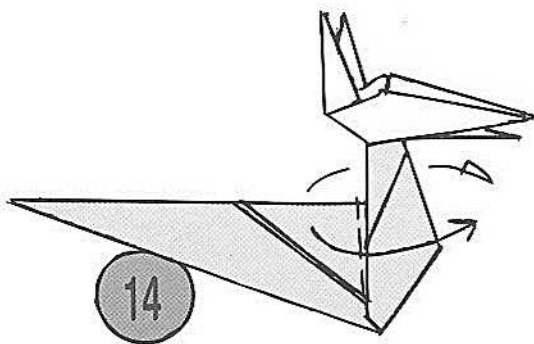
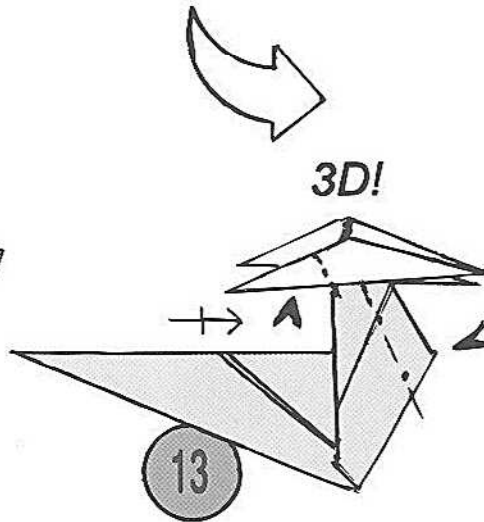
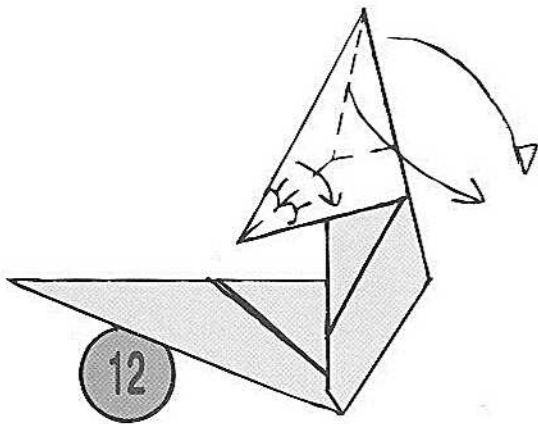
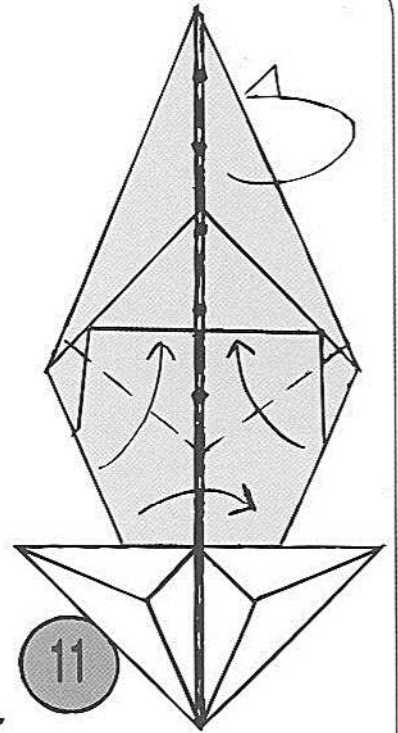
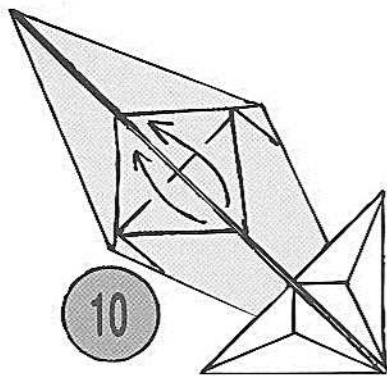
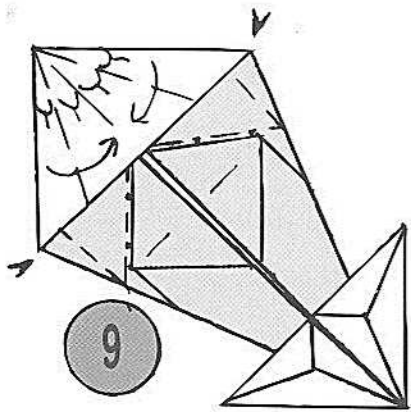



The pelican

Pelikán (2010)

Ratio

0.61

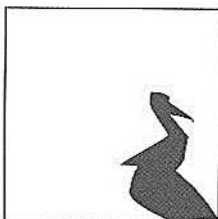

Suggested technique or paper:

-Tissue foil

-Wet-fold, weight of paper: 250 grams/m²

Paper color: White unicolour.

Suggested paper size: 25 cm.

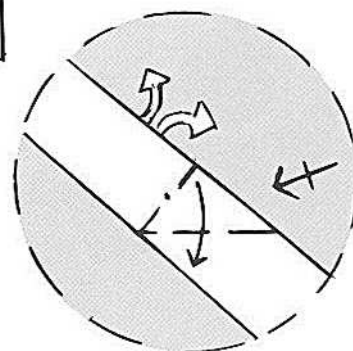
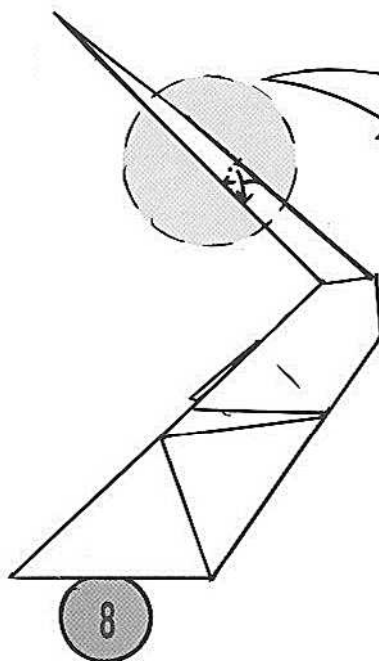
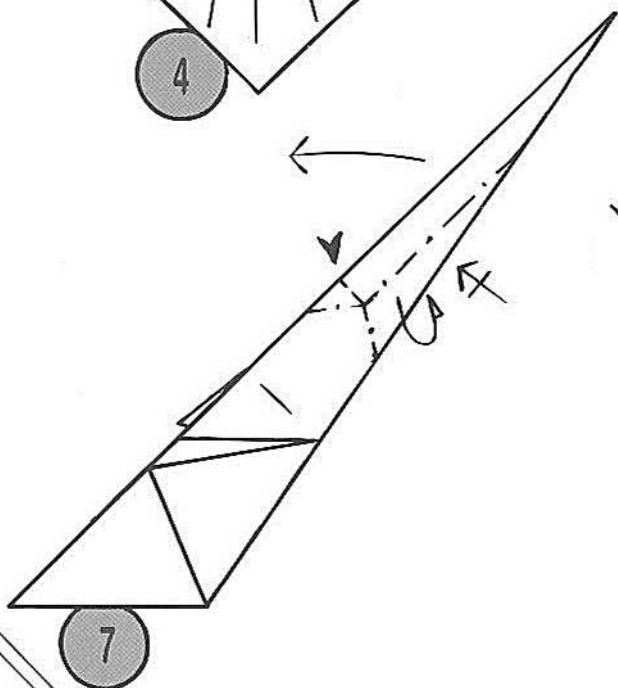
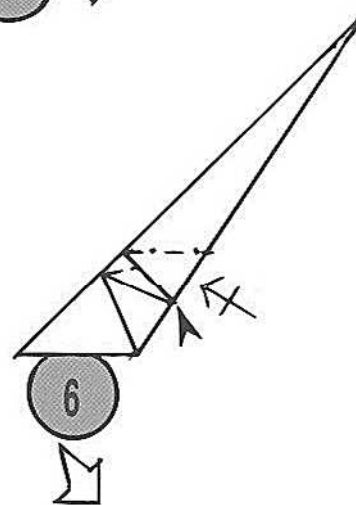
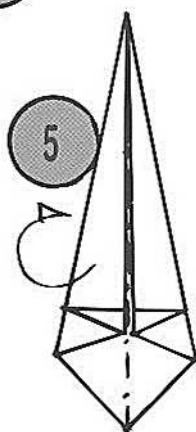
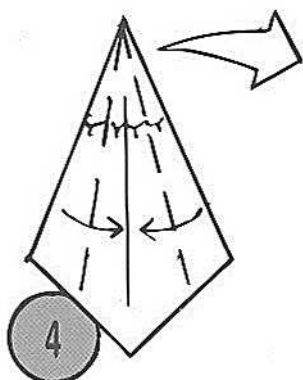
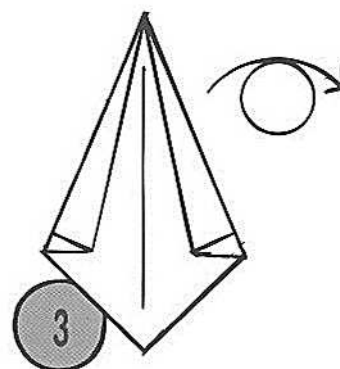
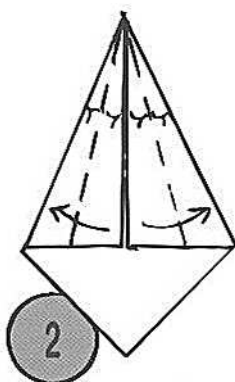
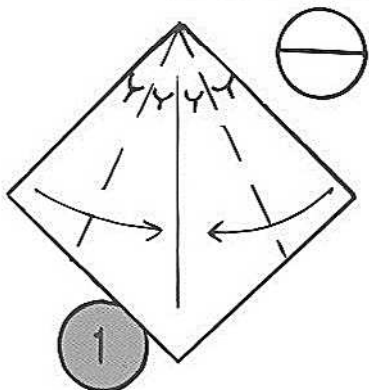

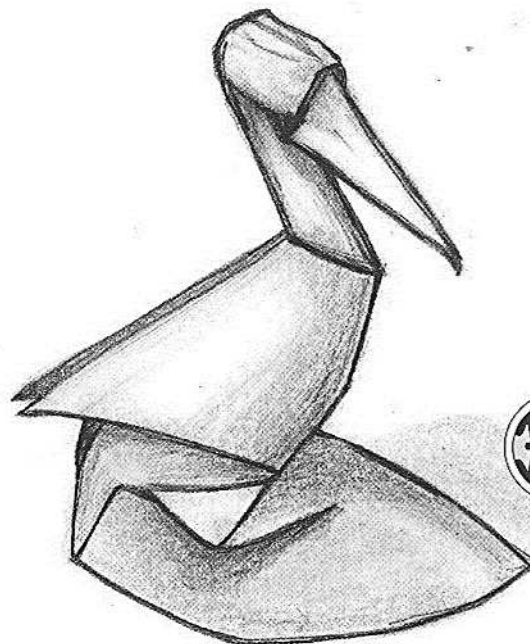
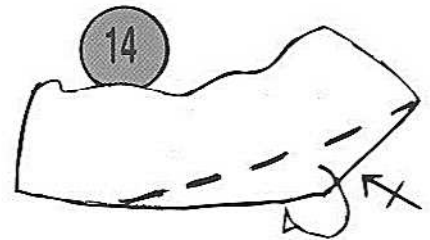
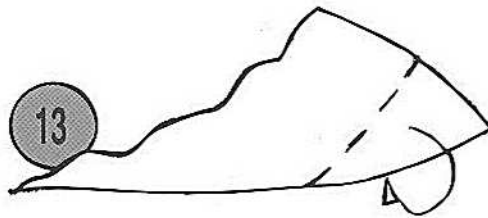
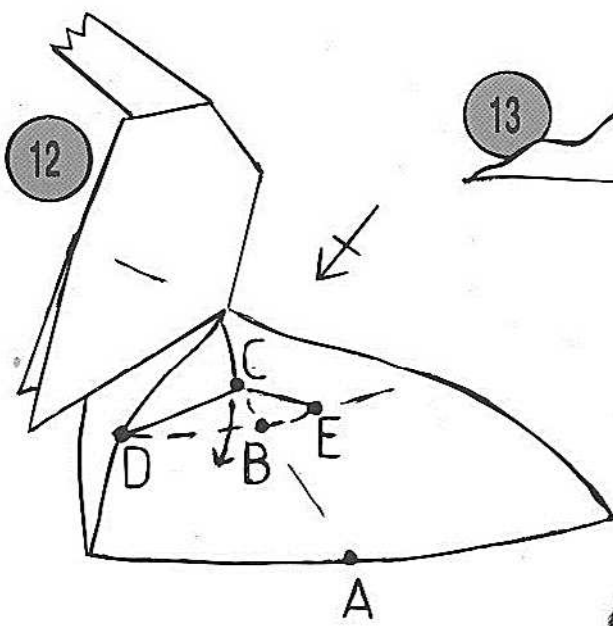
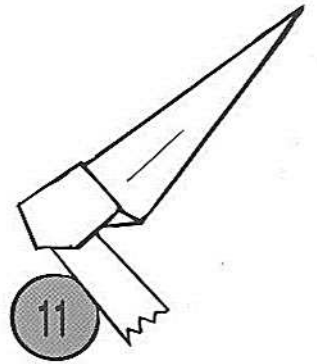
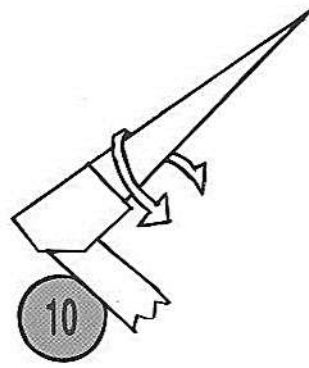
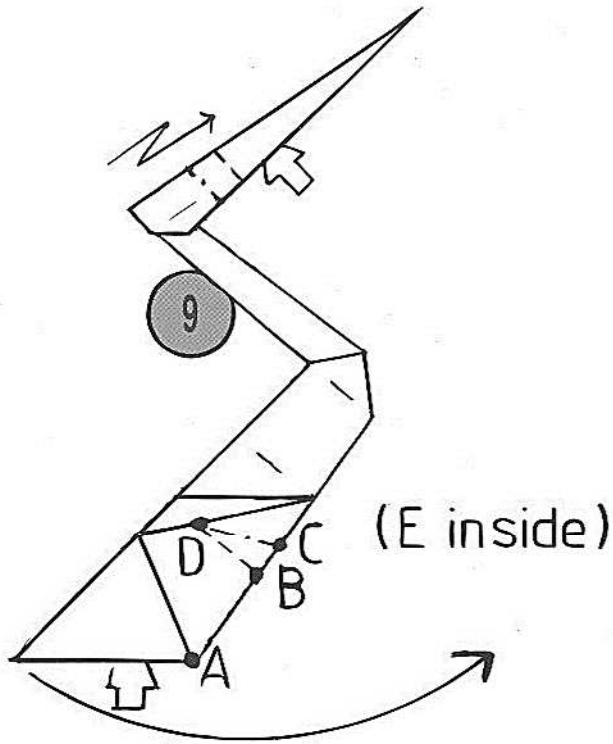

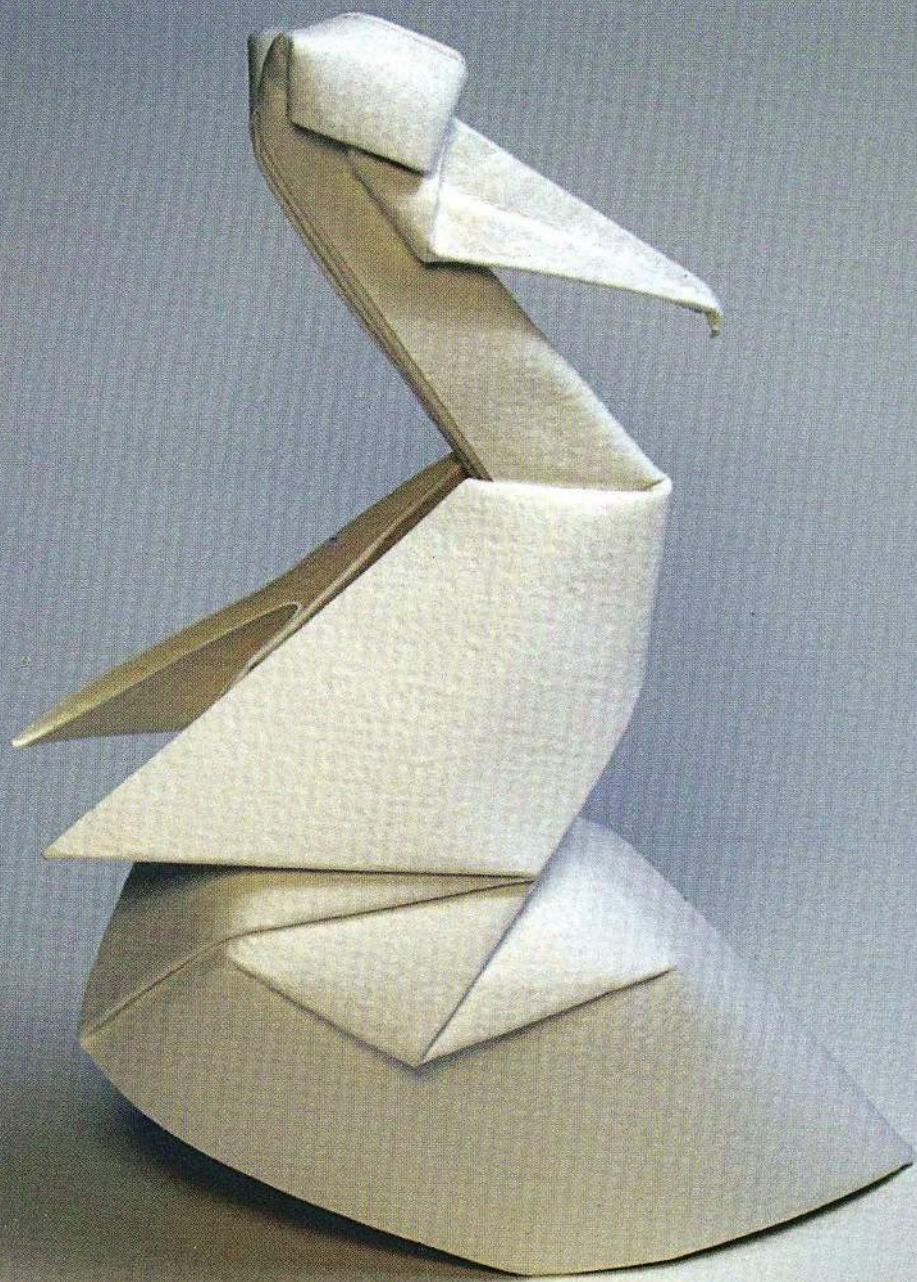

The T. rex

T-rex (2010)

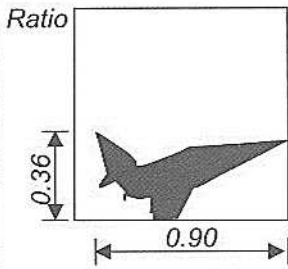

Suggested technique or paper:

- Tissue foil
- Wet-fold (Best option),
weight of paper: 250 grams/m²

Paper color: Any unicolour.
Suggested paper size: 25 cm.

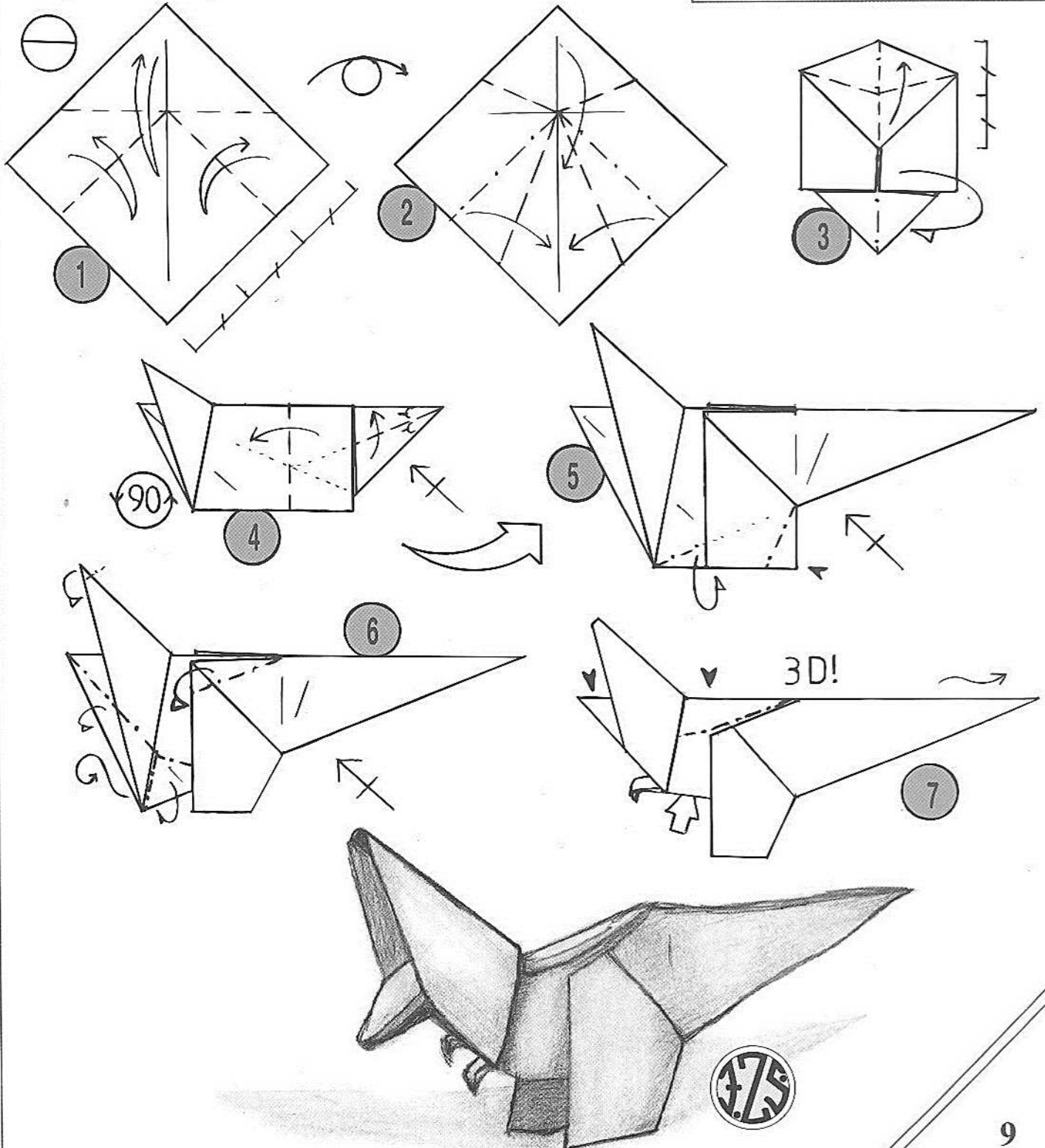
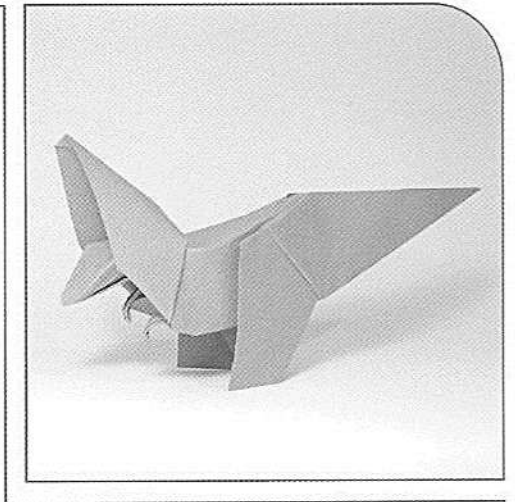



The goat

Kecske (2010)

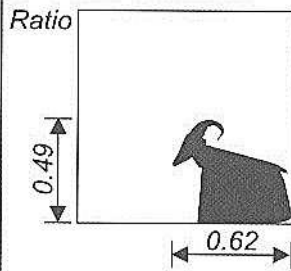

Suggested technique or paper:

- Tissue foil
- Wet-fold, weight of paper: 250 grams/m²

Paper color: Any unicolour.
Suggested paper size: 25 cm.

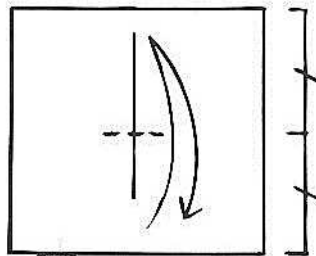

1

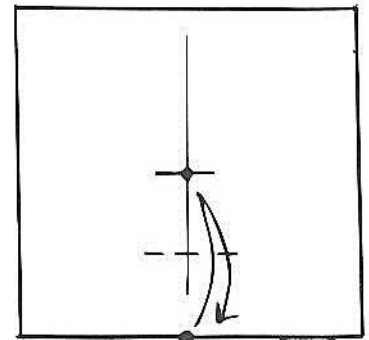

2

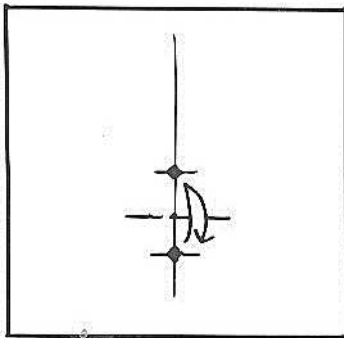

3

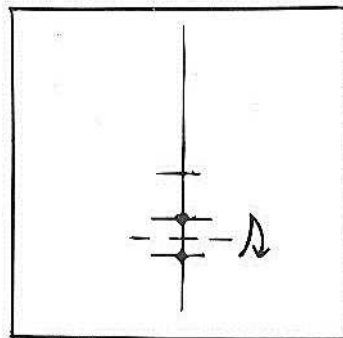

4

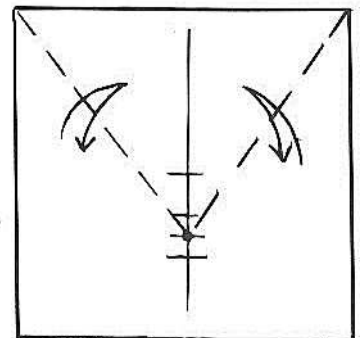

5

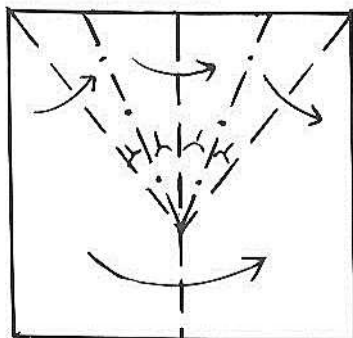

6

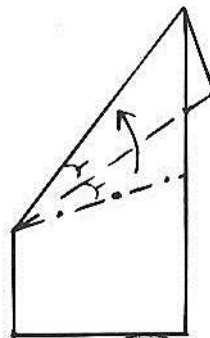

7

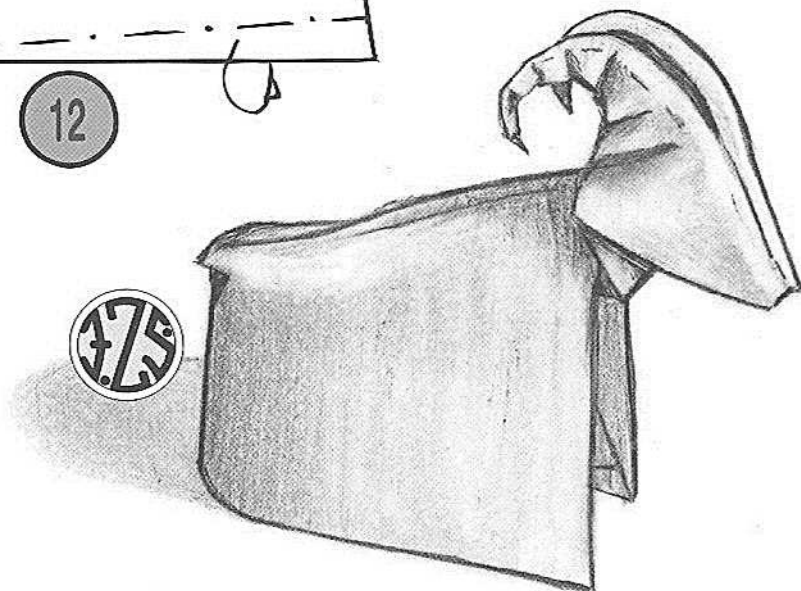
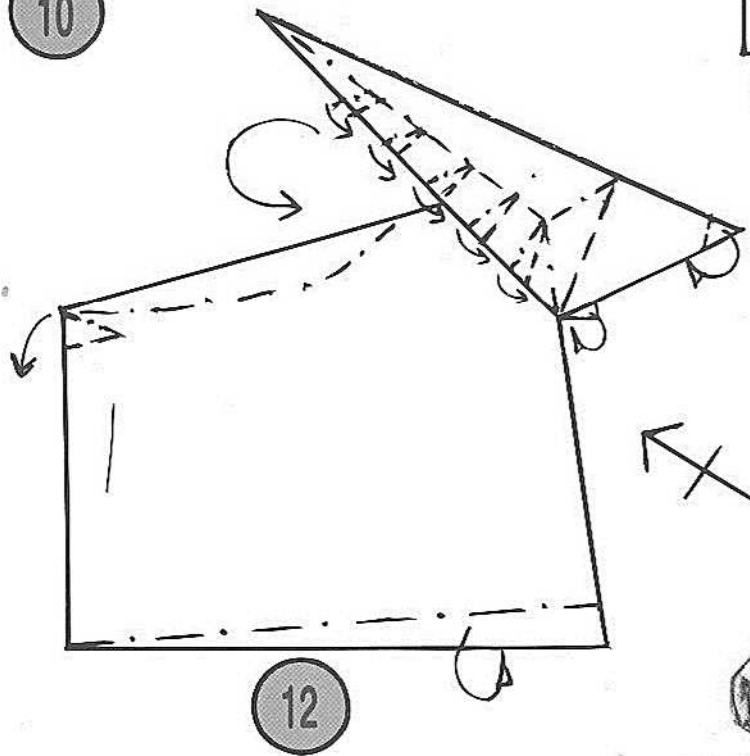
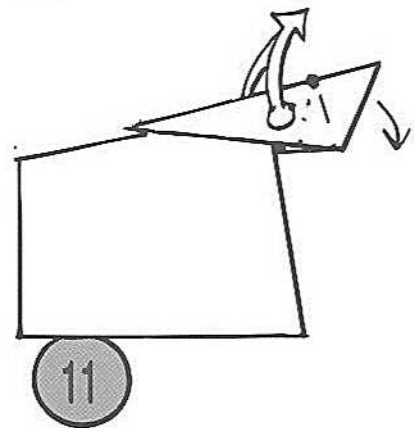
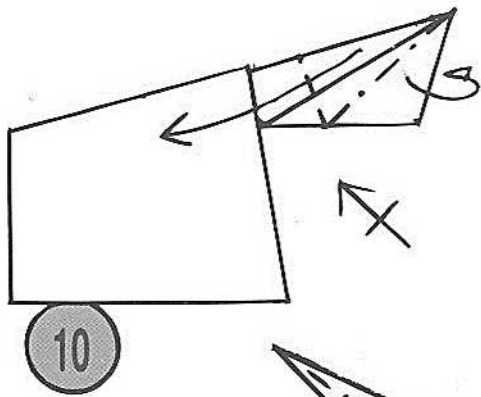
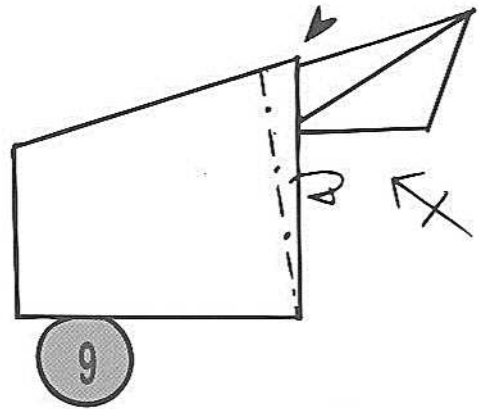
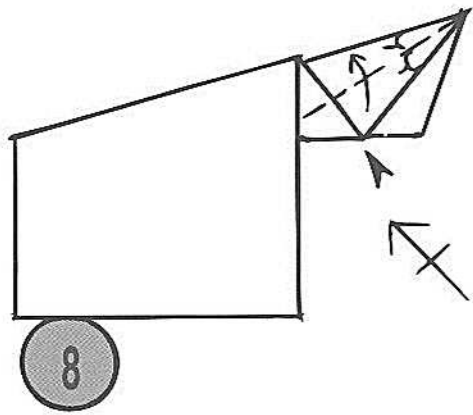

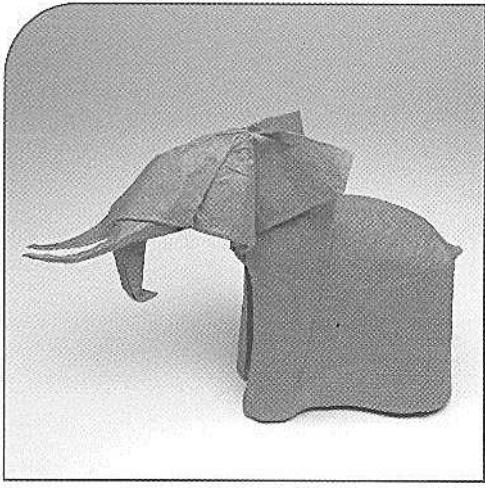

The bull elephant

Elefántbika (2011)

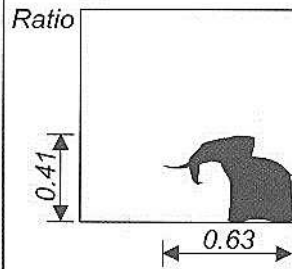

Suggested technique or paper:

- Tissue foil (Best option)
- Wet-fold, weight of paper: 300 grams/m²

Paper color: Any unicolour.

Suggested paper size: 30 cm.

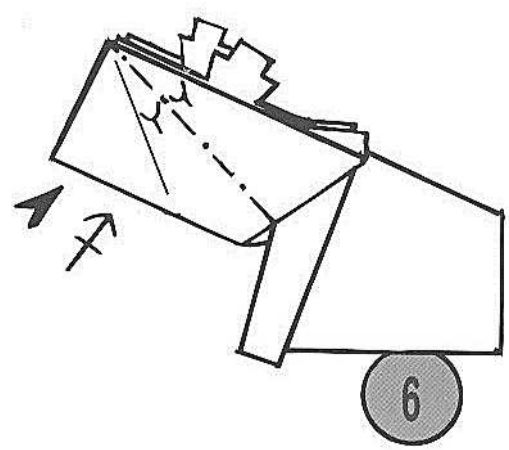
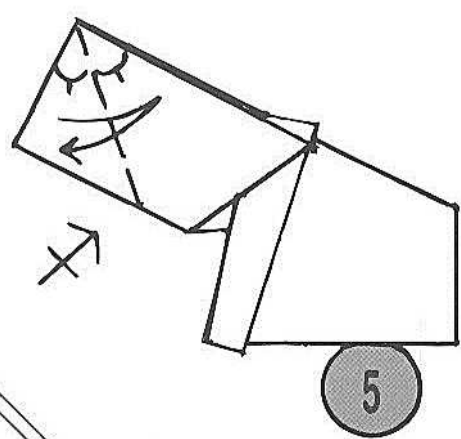
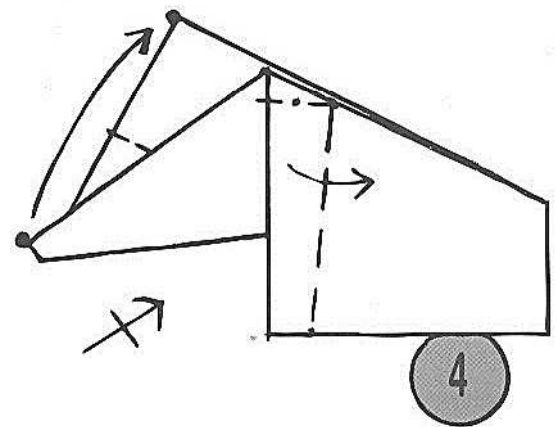
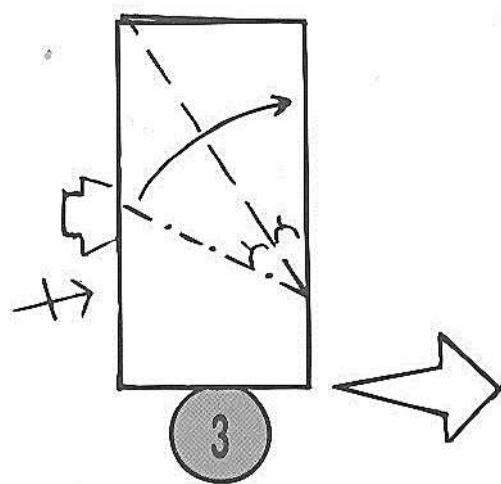
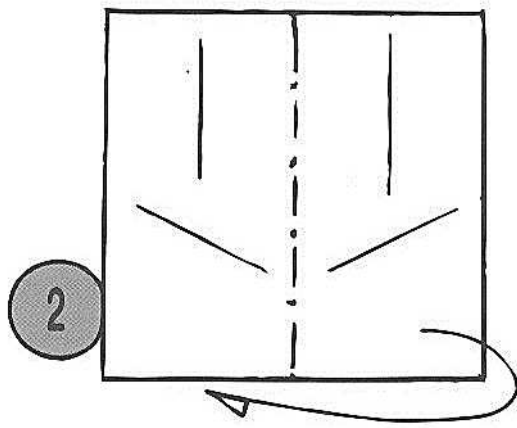
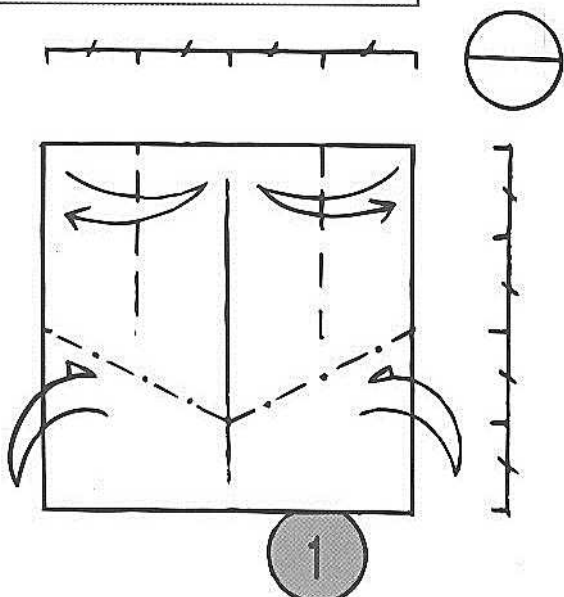

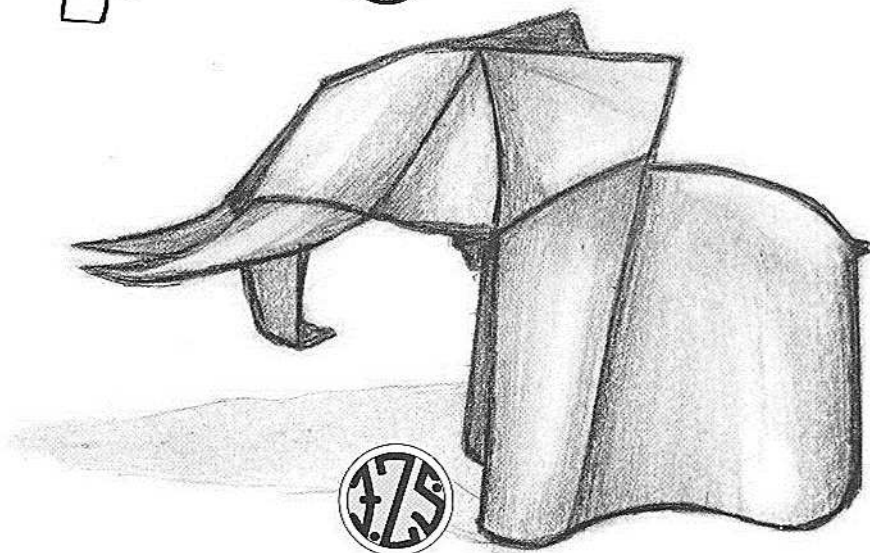
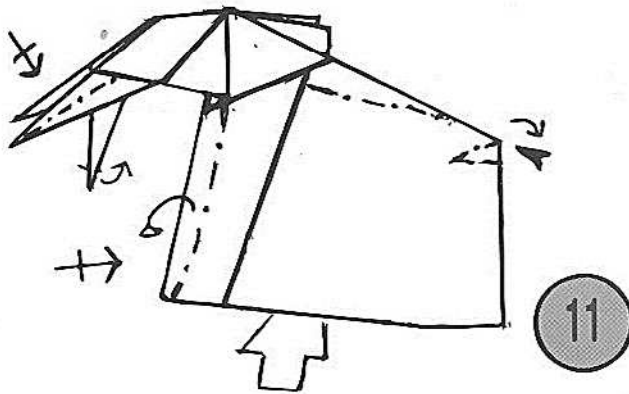
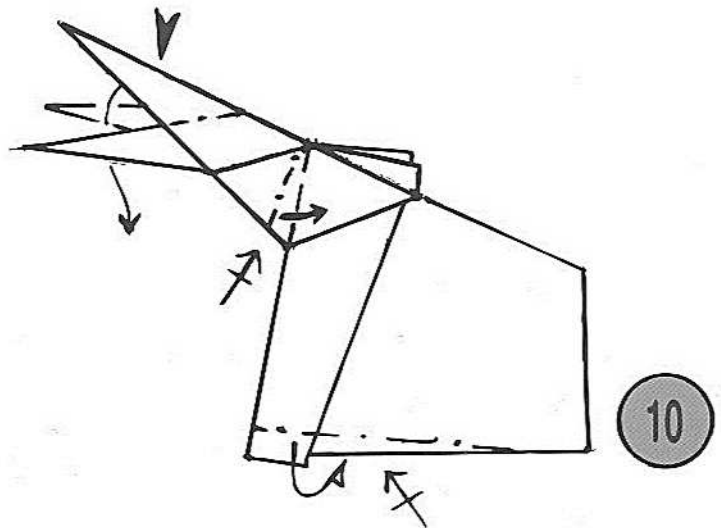
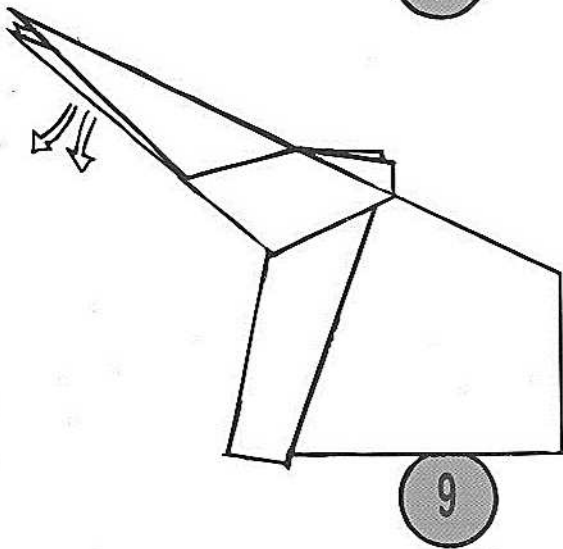
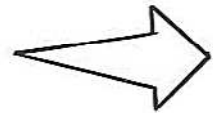
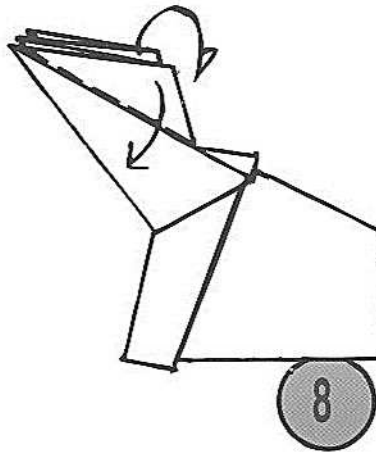
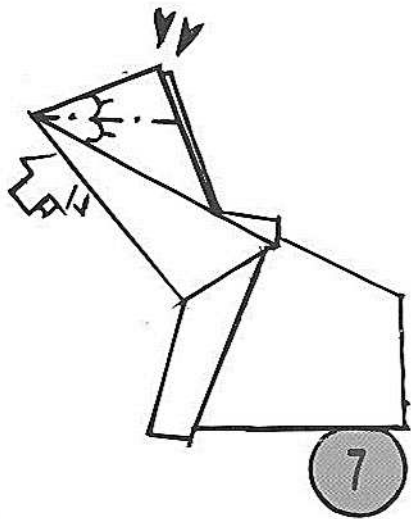





The dancer

Táncoló (2010)

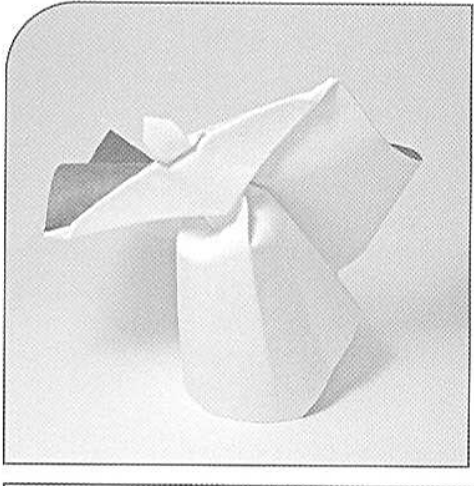

Ratio

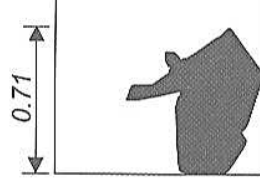

Suggested technique or paper:

- Tissue foil
- Wet-fold, weight of paper: 300 grams/m²

Paper color: Any bicolour .
Suggested paper size: 25 cm.

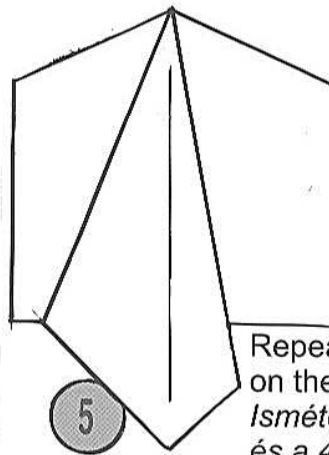
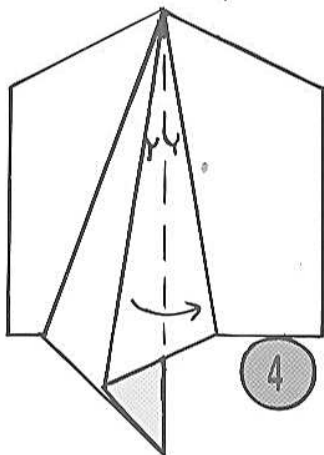
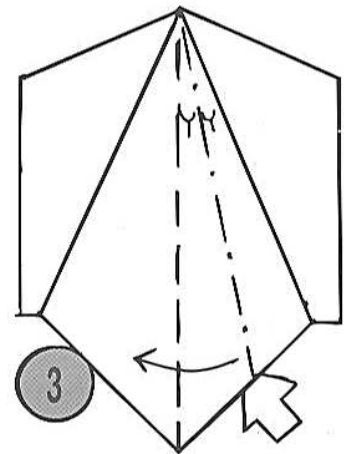
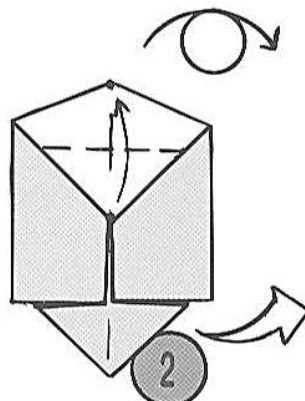
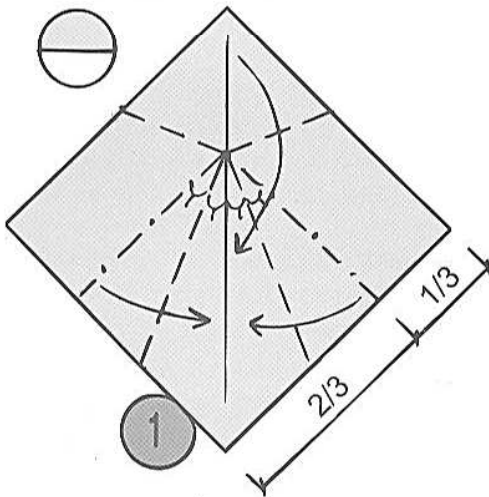

Repeat steps 3-4
on the left side.
*Ismételd meg a 3-as
és a 4-es lépést a bal
oldalon!*

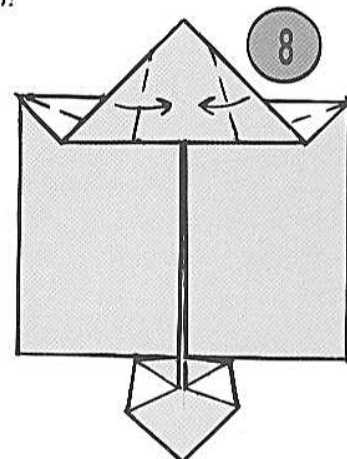
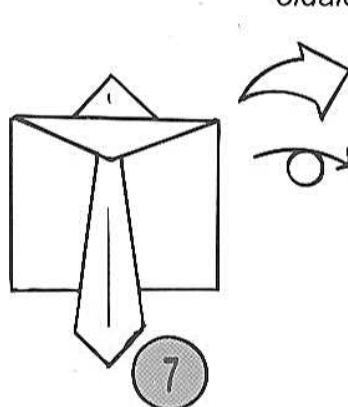
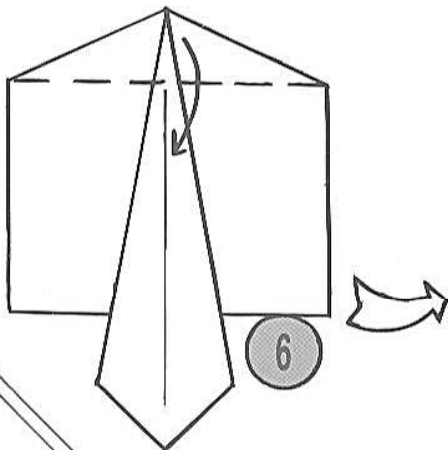

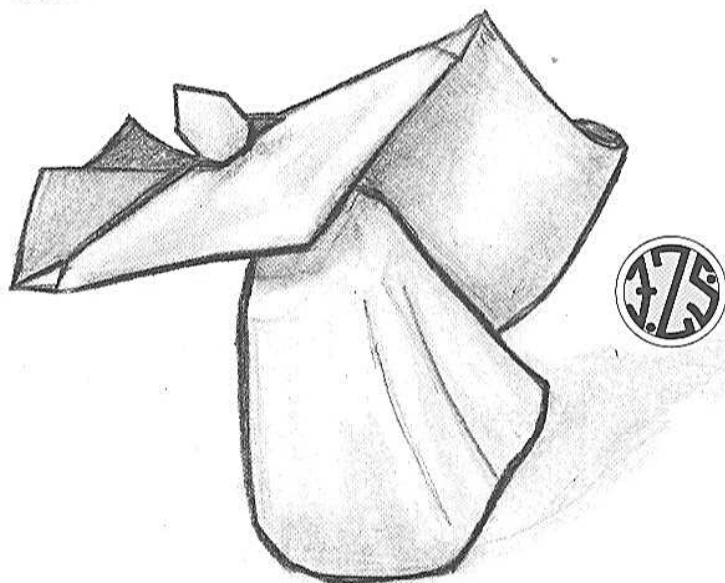
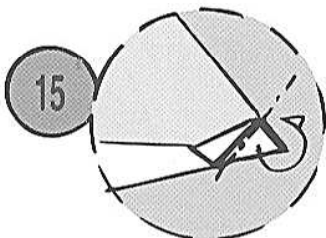
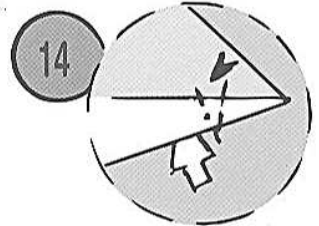
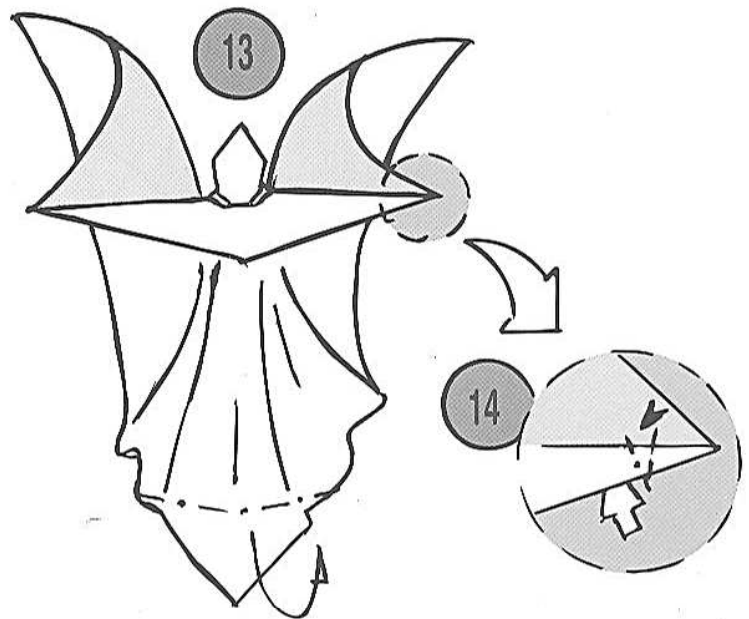
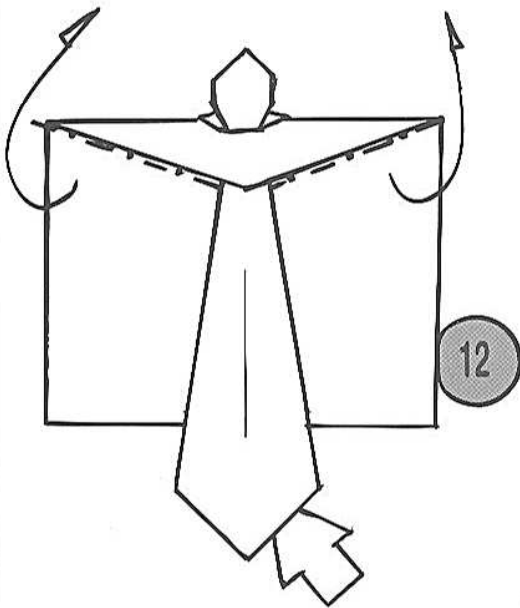
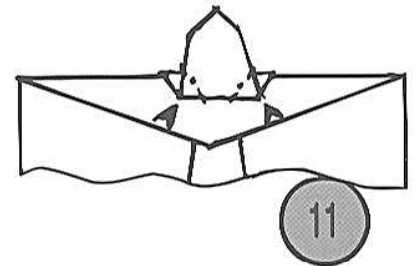
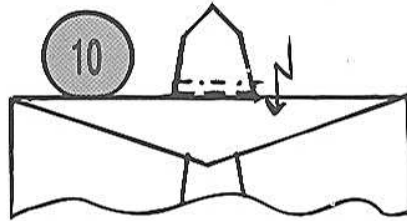
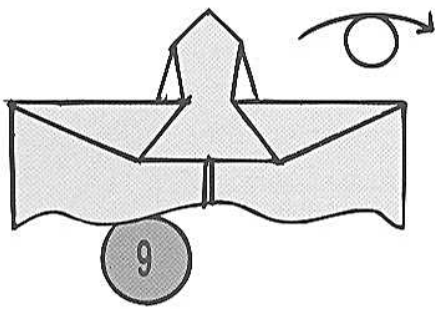

Shape the dress based on the photos or your own imagination.
Saját ötlet alapján vagy a fényképek szerint alakítsd ki a ruháját!

The fox

Róka (2012)

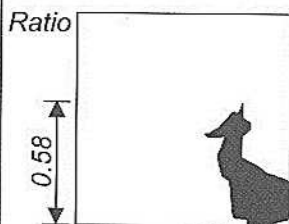
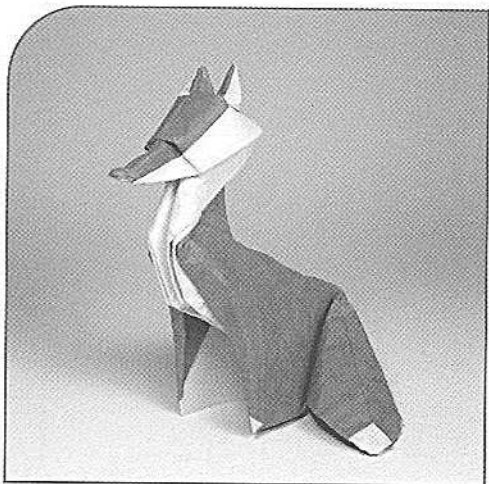

Suggested technique or paper:

- Traditional origami paper
- Tissue foil (Best option)
- Wet-fold

Paper color: Red-white.

Suggested paper size: 25 cm.

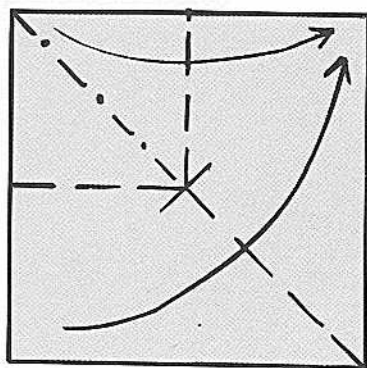

1

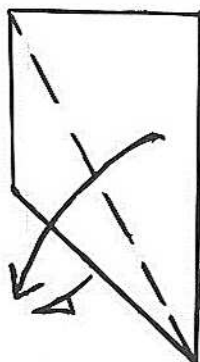

2

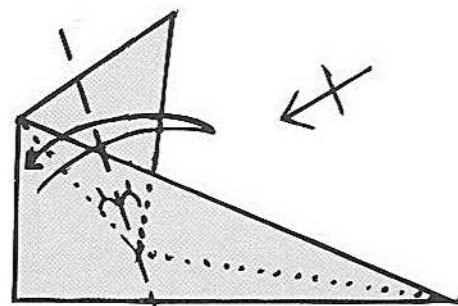

3

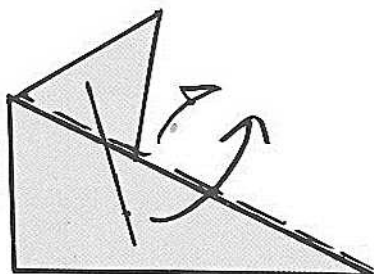

4

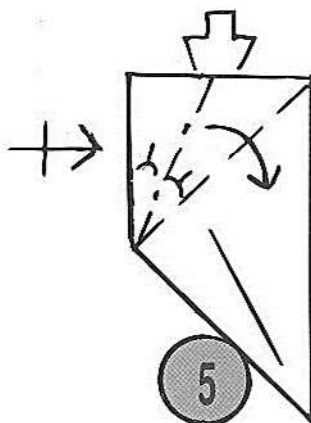

5

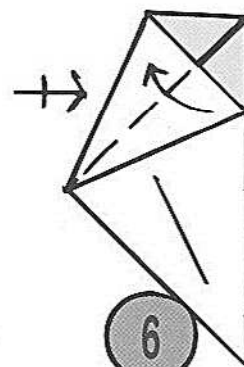

6

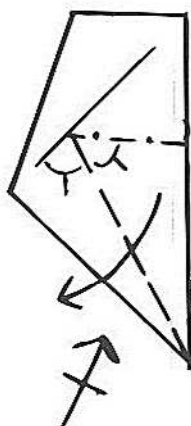

7

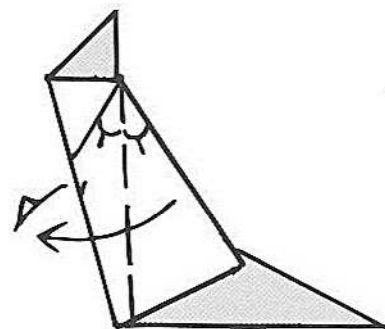

8

Use the existing creases to fold this step.
A meglévő hajtvonalakat használd!

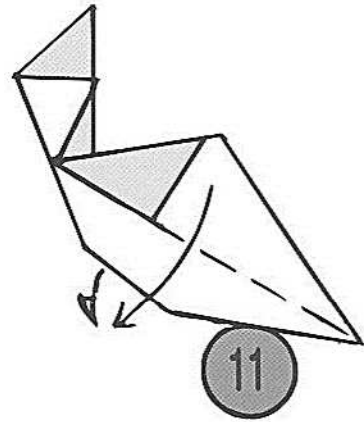
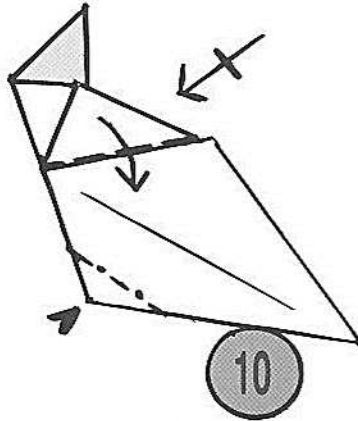
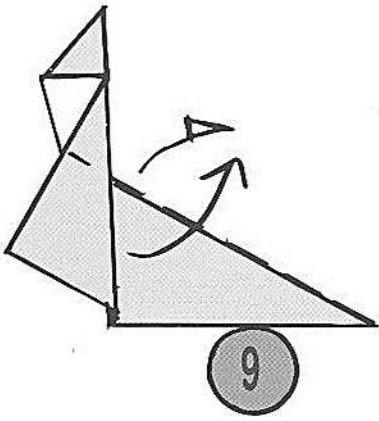

This sink fold is an open sink.
A süllyesztés nyitott.

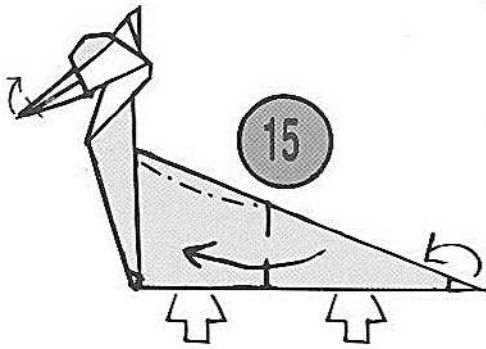
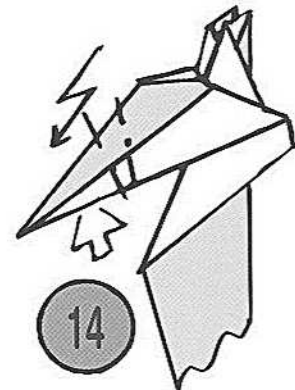
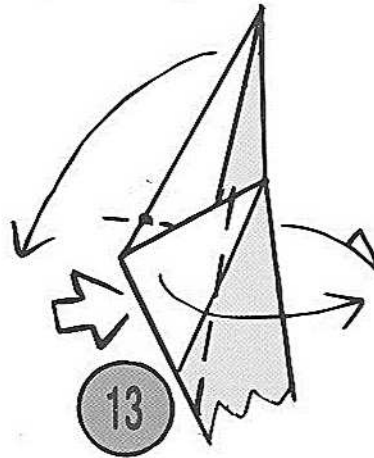
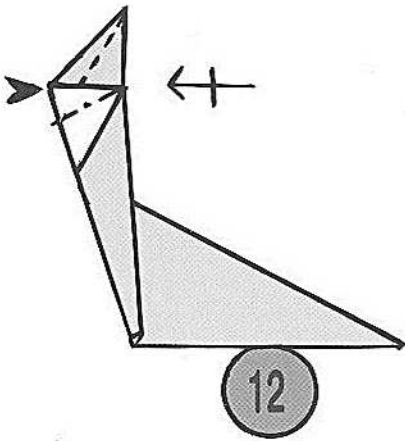



The pigeon

Galamb (2010)

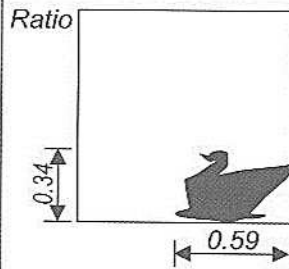

Suggested technique or paper:
-Only wet fold, watercolor paper,
weight: 600 grams/m²

Paper color: White unicolour.
Suggested paper size: 25 cm.

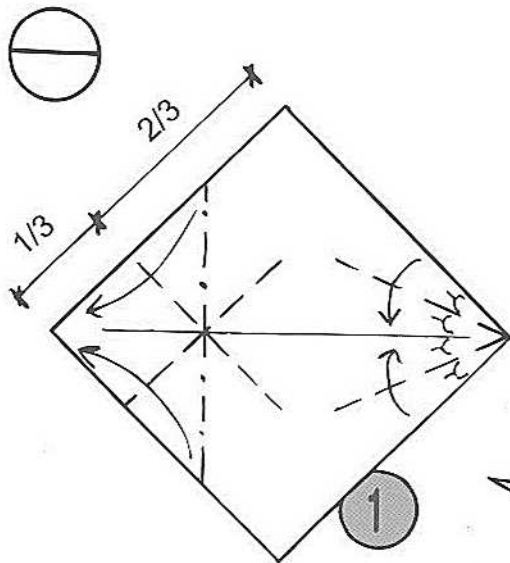

3D!

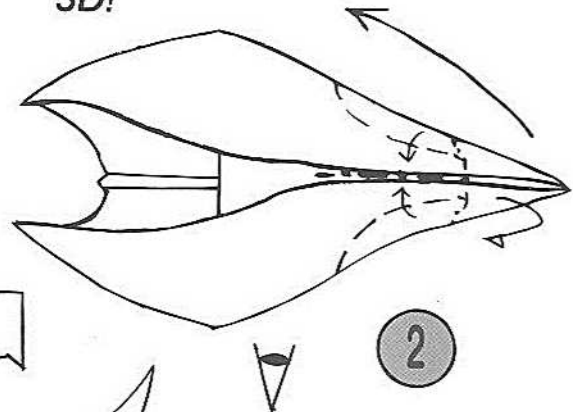

The diagram alone may not be enough to shape the model well. Have a look at the photo for help.
A modell kialakításához nem elég csak a diagramot és a rajzot használni. Nézd a fotót is!

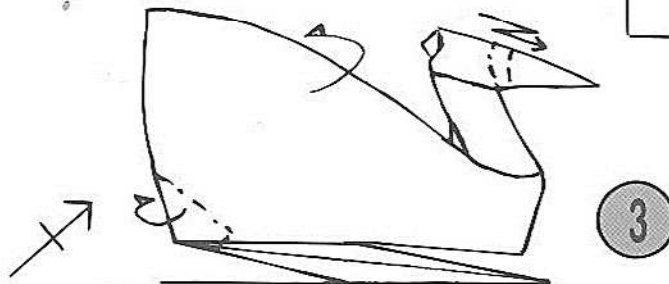

The corner of the square should be exposed under the craw.
A négyzet sarka kilátszik a begye alól!

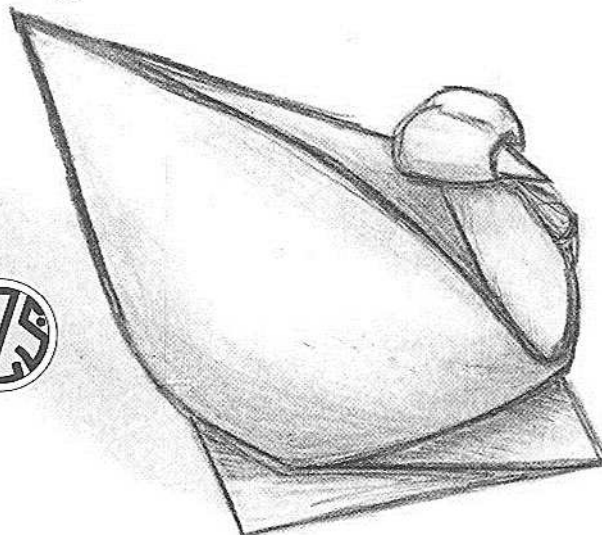



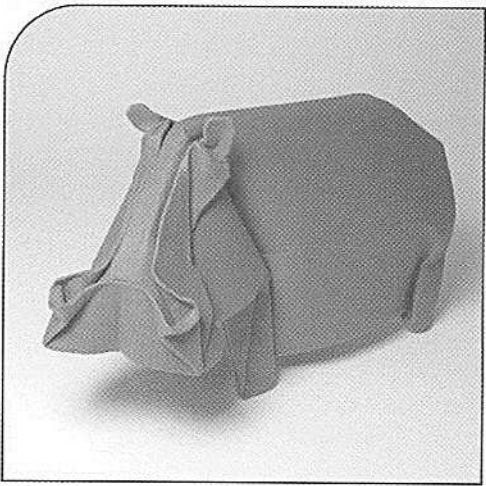

The hippopotamus

Víziló (2003)

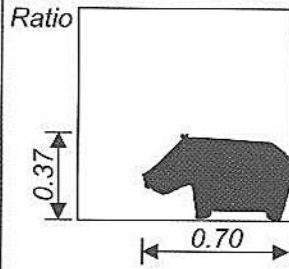

Suggested technique or paper:

- Tissue foil
- Wet-fold (Best option), weight of paper: 300 grams/m²

Paper color: Any unicolour.
Suggested paper size: 30 cm.

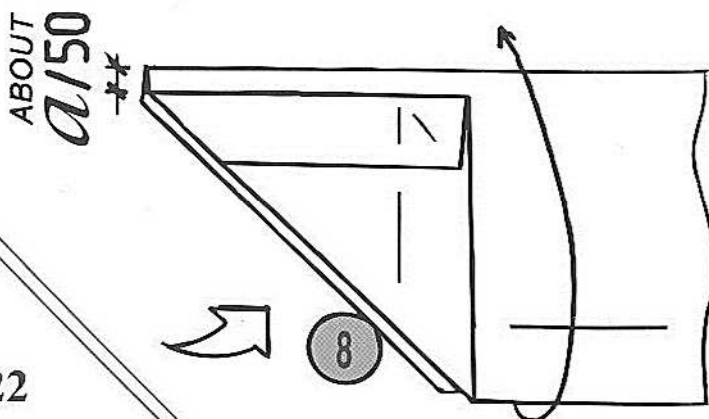
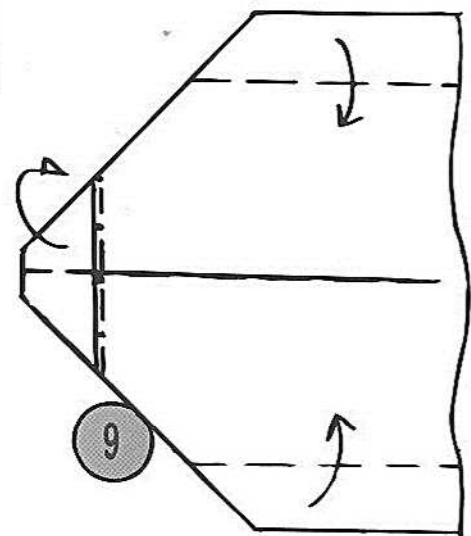
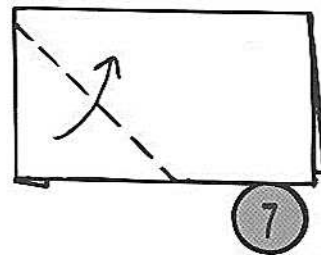
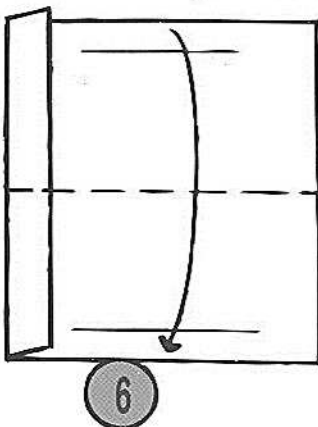
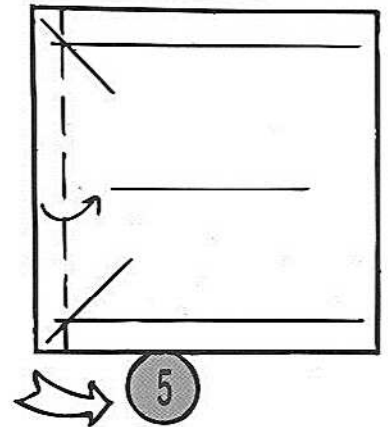
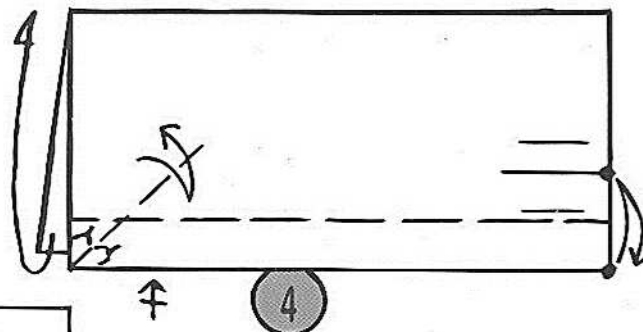
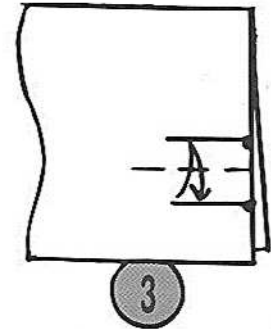
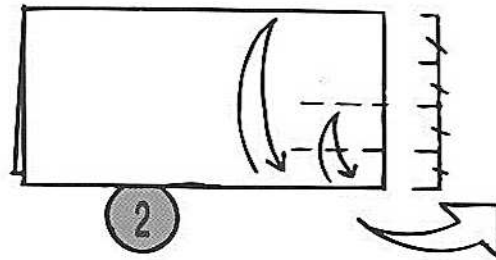
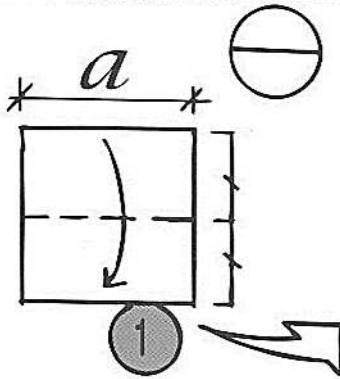

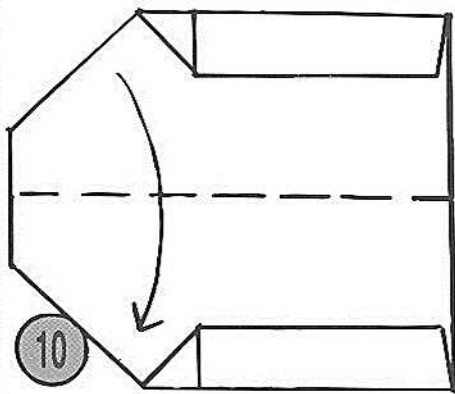

10

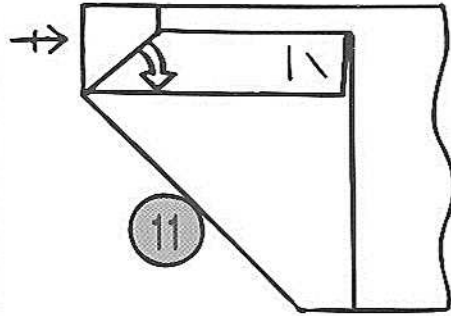

11

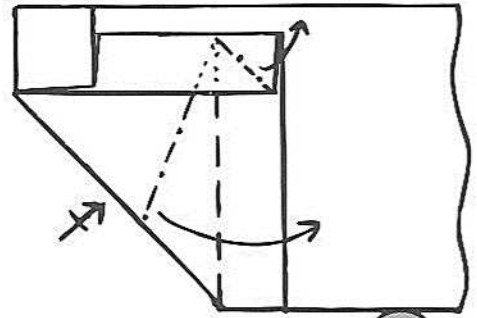

12

3D!

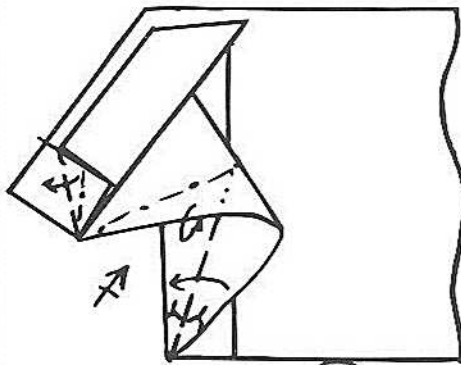

13

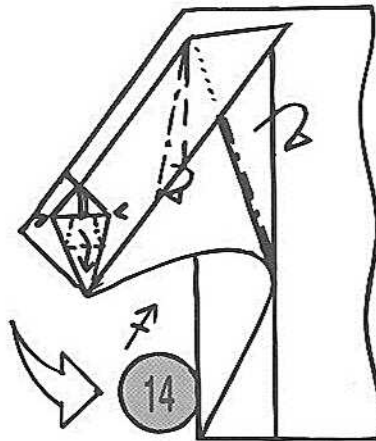

14

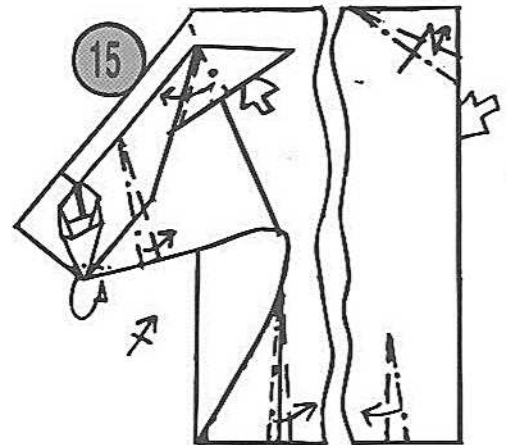

15

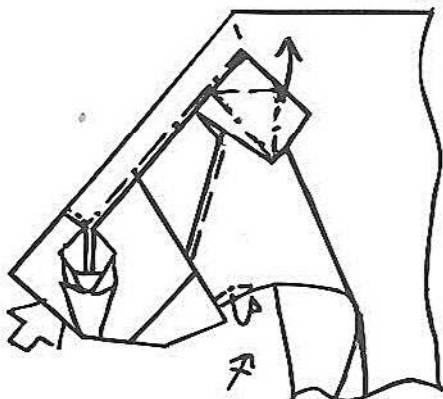

16

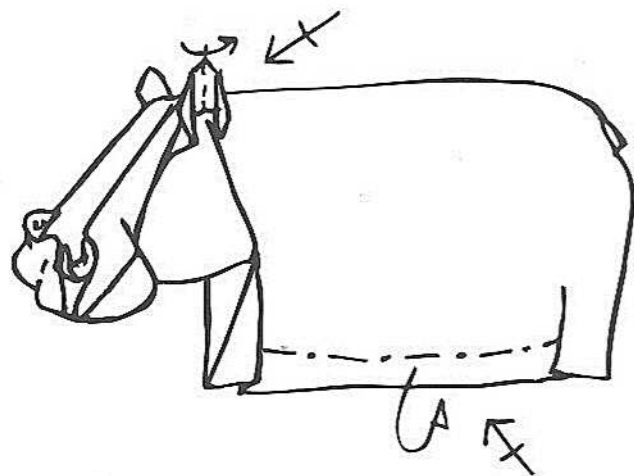

17

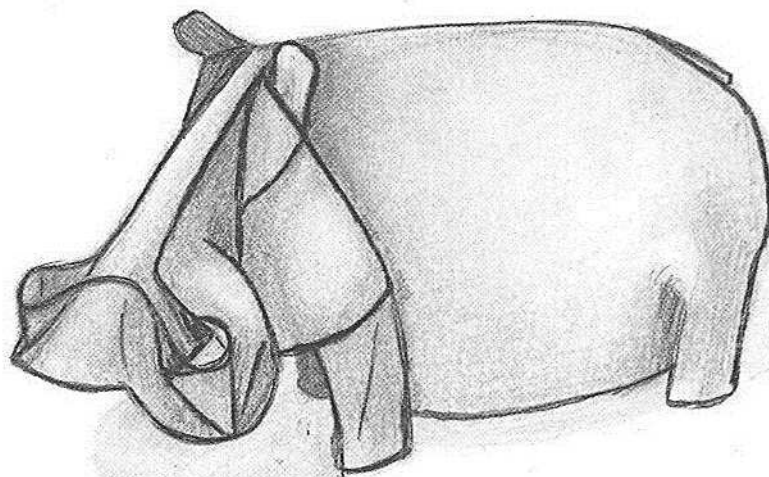



The bear

Medve (2011)

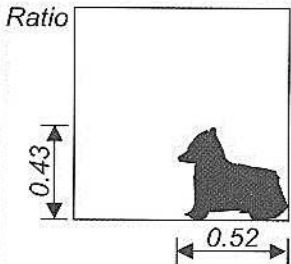

Suggested technique or paper:
 -Tissue foil (Best option)
 -Wet-fold

Paper color: Brown-black.
 Suggested paper size: 25 cm.

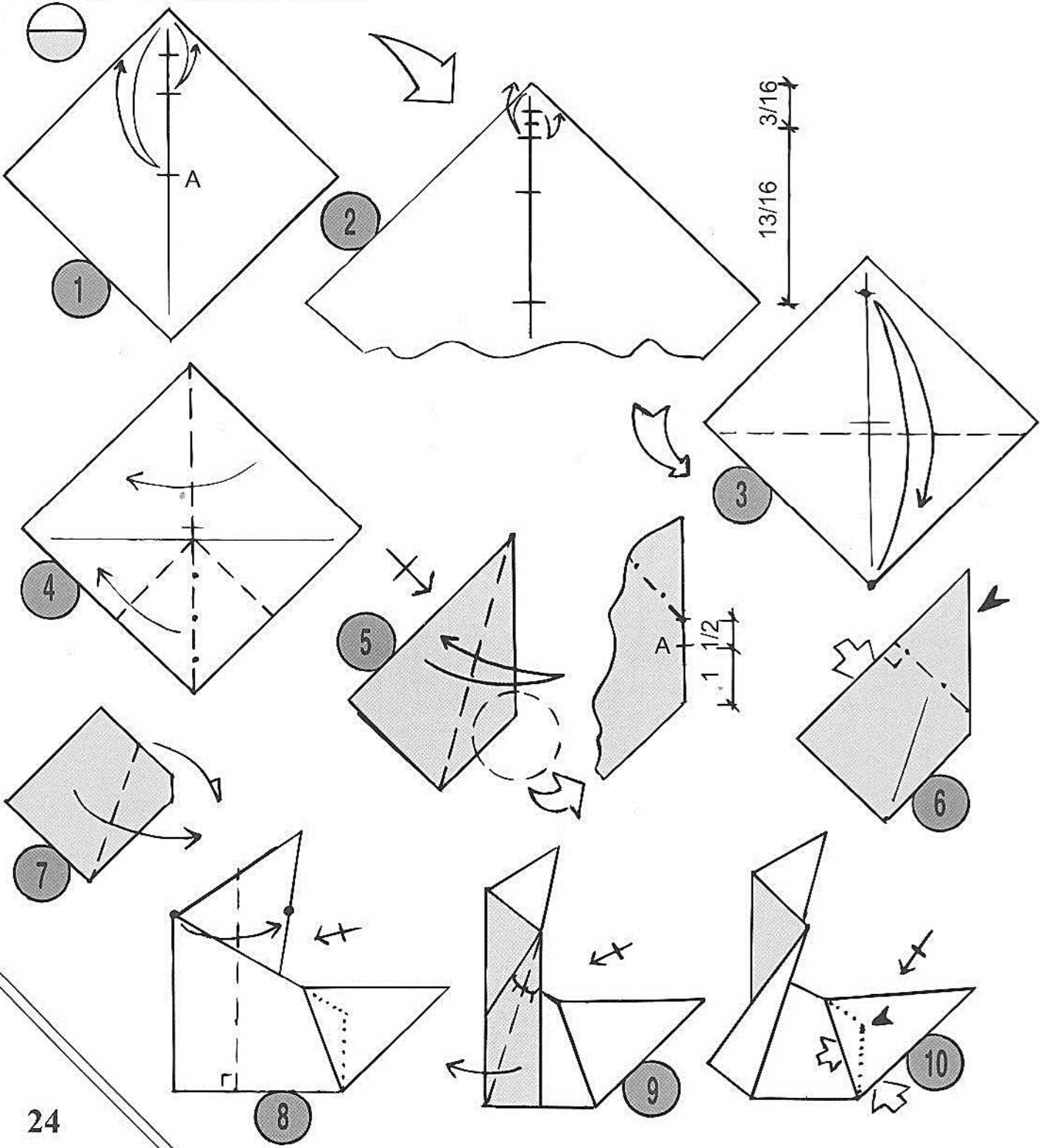

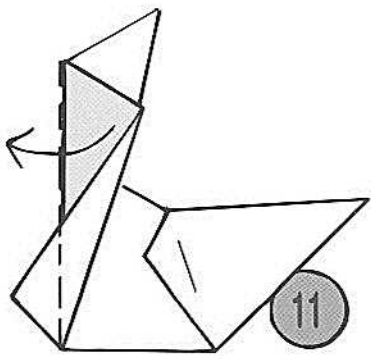

11

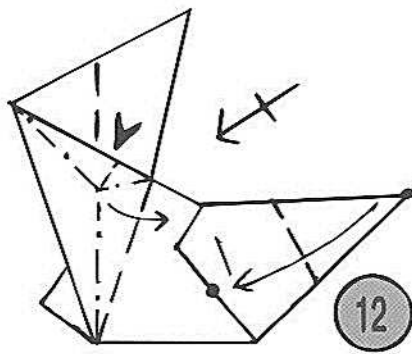

12

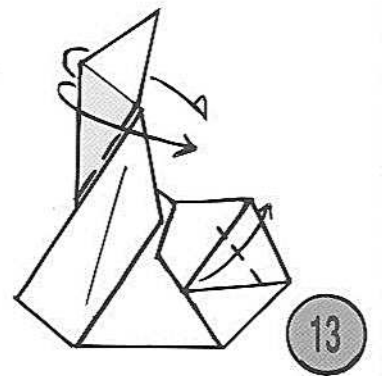

13

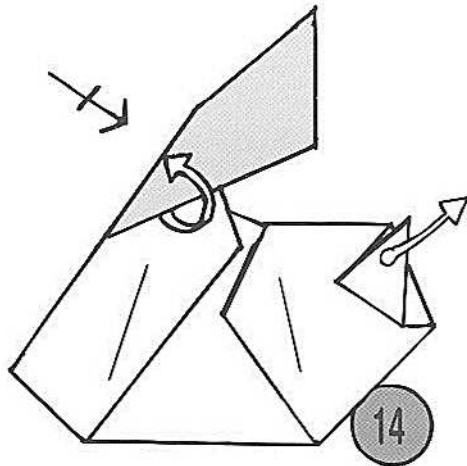

14

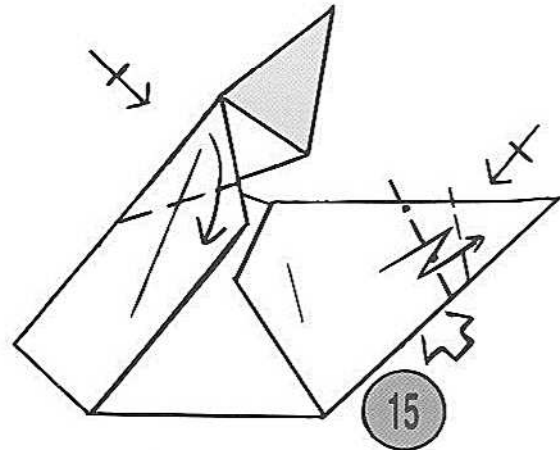

15

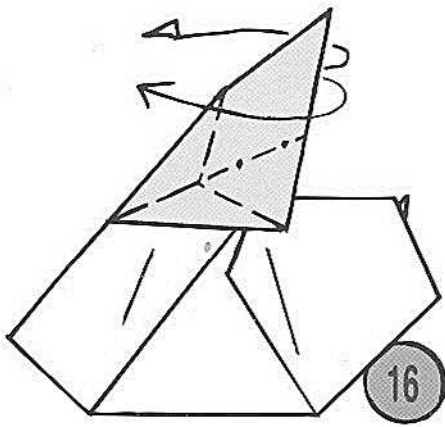

16

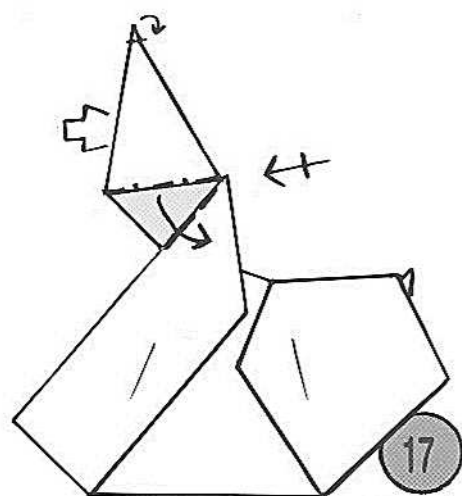

17

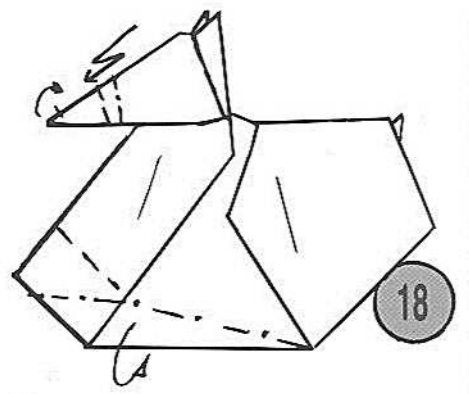

18

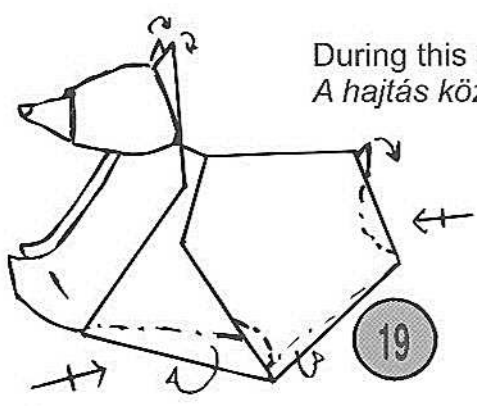

19

During this step, pull down the head to form the ears.
A hajtás közben húzd a fejét lefele, hogy a füle kialakuljon!

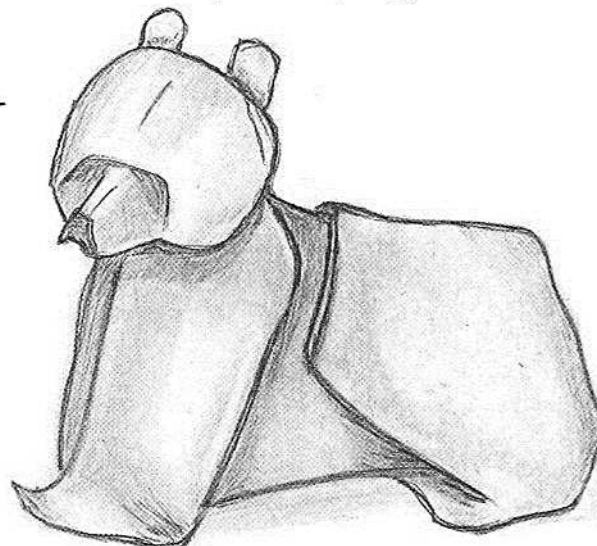

Symbols

Jelölések

Unicolour paper.
Egyszínű papír.



Bicolour paper.
Kétszínű papír.



Valley fold. Fold the paper towards yourself.
Völgyhajítás. Hajtsd magad felé a papírt!

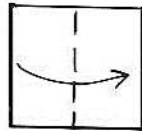

Turn over the model.
Fordítsd meg a figurát!

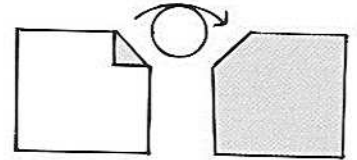

Mountain fold. Fold back the paper behind!
Hegyhajítás. Hajtsd hátra a papírt!

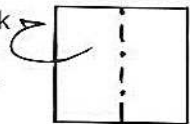

Rotate the model.
Forgasd el a modellt a jelzett irányba, a megadott szöggel!

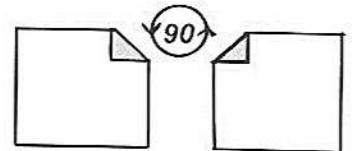

Pleat-fold direction.
Harmónikahajítás.

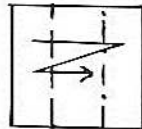

Repeat the folds behind.
Ismételd meg a hajítást a túloldalon!

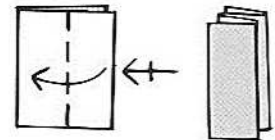

Valley fold and unfold.
Oda-vissza hajítás.

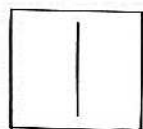
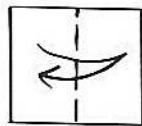

Unfold or fold out.
Széthajítás, kihajítás.

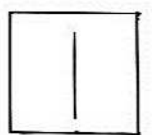
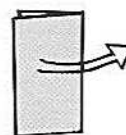

X-ray view.
Röntgen vonal.

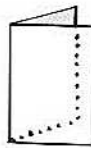

Open the model in the indicated location.
Nyisd szét a modellt a jelzett helyen!

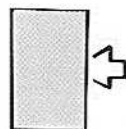

Open sink. Push the paper here.
Nyitott horpasztás, benyomás.

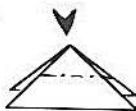

Zoom in.
Nagyítás.

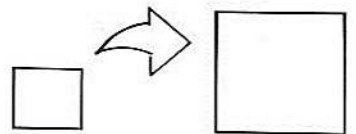

Equal distances.
Egyenlő távolságok.

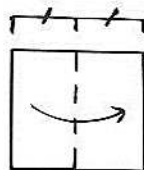

Zoom out.
Kicsinyítés.

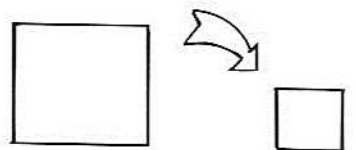

Equal angles.
Egyenlő szögek.

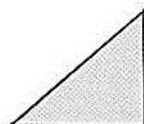
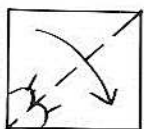

View the model from this vantage point.
Új nézet iránya.



Division of side into three equal sections

A négyzet oldalának harmadolása

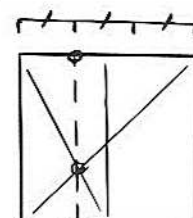
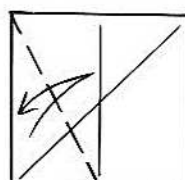
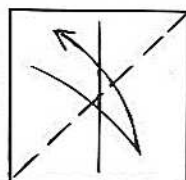
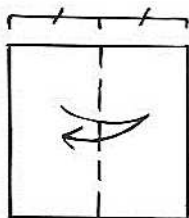

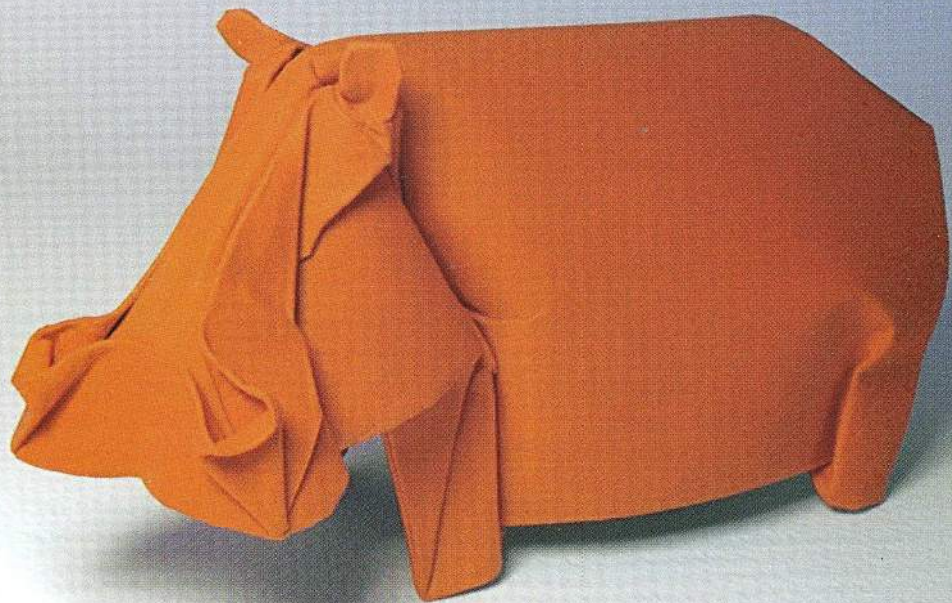

Content

Tartalom

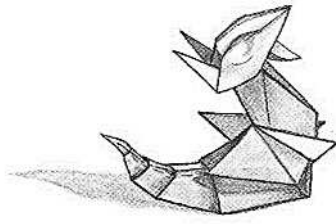

4. The little dragon
.Kis sárkány



6. The pelican
.Pelikán

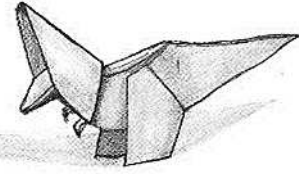

9. The T-rex
.T-rex

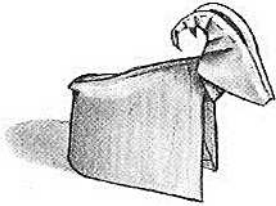

10. The goat
.Kecske

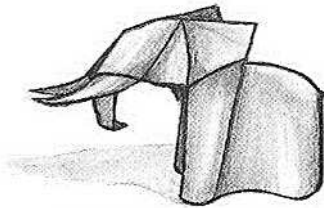

12. The bull elephant
.Elefánt bika

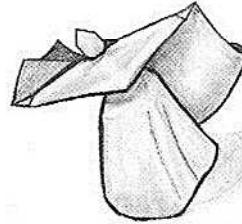

16. The dancer
.Táncoló



18. The fox
.Róka

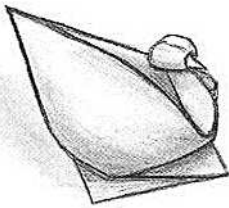

20. The pigeon
.Galamb

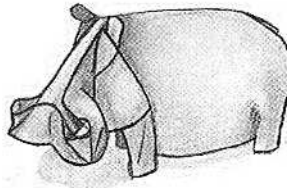

22. The hippopotamus
.Víziló



24. The bear
.Medve

Publisher (Kiadja):

Zsebe József
7052 Kölesd, Szekszárdi u. 8. Hungary

<http://www.flickr.com/photos/65167262@N04/>
jozsef.zsebe@freemail.hu
jozsefzsebe@yahoo.com

Supporter (Támogató):

Fáraó '95 Oktatásszervező Kft.
7100 Szekszárd, Herman Ottó utca 37. Hungary

Photos, handmade diagrams and drawings (Fotók, kézi diagramok és rajzok): Zsebe József.
Computer processing and editing (Számítógépen feldolgozta és szerkesztette): Sebők Zsolt.
Translators (Fordították): Dr. Budai Péter, Karfner Judit. **Printing** (Nyomdai munkák): Tóth Andrásné.

ISBN 978-963-08-4896-1

All rights reserved. No part of this book may be reproduced or transmitted in any form or by any means, electronic or mechanical, including photocopying, recording, or by any information storage and retrieval system, without prior written permission from the publisher.

Minden jog fenntartva. A könyv bármely részéről másolatot készíteni bármilyen formában, akár elektronikus, akár mechanikus úton ideértve a fénymásolást, vagy bármely más adattörzítésre alkalmas eszközt a Kiadó előzetes írásbeli engedélye nélkül tilos.

József Zsebe is a leading figure in the Hungarian and international origami community. His new perspective and technique have contributed to his quick acknowledgement in origami circles. His works of art are characterised by maximum paper usage and sculptural folding methods.

His publication entitled "Fold line" introduces the new movement which is aiming for a compact, essence driven representation. This book enables readers to gain insight into the author's paper world and experience the joy of creation.

Judit Sági

Zsebe József a magyar és nemzetközi origami élet meghatározó egyénisége. Új látásmódjával és technikájával szinte berobbant az origamis köztudatba. Alkotásaira az egyszerű vonalak, a maximális papírkihasználtság, a szoborszerű alkotásmód jellemző.

A "Hajtásvonal" című kötet egy olyan új irányvonalat képvisel, ami a papírhajtogatás lényegre törő, tömör megfogalmazásában rejlik. Ez a könyv lehetőséget ad nekünk, hogy mi is beeláthassunk az Ő általa megformált "papírvilágba" és átélhessük az alkotás örömét.

Sági Judit

ISBN 978-963-08-4896-1



9 789630 848961